

1966

Optimum design of multi-story frames by plastic theory, March 1966 M.S. Murray

T. M. Murray

A. Ostapenko.

Follow this and additional works at: <http://preserve.lehigh.edu/engr-civil-environmental-fritz-lab-reports>

Recommended Citation

Murray, T. M. and Ostapenko, A., "Optimum design of multi-story frames by plastic theory, March 1966 M.S. Murray" (1966). *Fritz Laboratory Reports*. Paper 114.

<http://preserve.lehigh.edu/engr-civil-environmental-fritz-lab-reports/114>

This Technical Report is brought to you for free and open access by the Civil and Environmental Engineering at Lehigh Preserve. It has been accepted for inclusion in Fritz Laboratory Reports by an authorized administrator of Lehigh Preserve. For more information, please contact preserve@lehigh.edu.

LEHIGH UNIVERSITY
Bethlehem, Pennsylvania

Department of Civil Engineering
Fritz Engineering Laboratory

273

August 4, 1966

MEMBERS, LEHIGH PROJECT SUBCOMMITTEE (WRC)

Messrs:	T. R. Higgins	E. R. Estes	K. H. Koopman
	J. H. Adams	G. F. Fox	C. Kreidler
	A. Amirikian	J. A. Gilligan	N. M. Newmark
	L. S. Beedle	L. Grover	N. Perrone
	J. M. Crowley	I. Hooper	E. Pissetzner
	C. F. Diefenderfer	B. G. Johnston	J. Vasta
	F. H. Dill	R. L. Ketter	C. F. Larson

Re: Project Ser. No. SF 103-03-01, Task 1974
Fritz Engineering Laboratory Report No. 273.42
"Optimum Design of Unbraced Multi-Story Frames
by Plastic Theory" by T. M. Murray and A. Ostapenko

Gentlemen:

The enclosed report presents a study on optimum design of multi-story frames by plastic theory. Besides the theory it gives a detailed description of the computer program prepared to perform the design.

We are planning to submit this report for publication in the Structural Journal of the ASCE proceedings and would greatly appreciate your review and comments by the end of August.

Sincerely yours,



Alexis Ostapenko

AO:mlc

Plastic Design of Multi-Story Frames

OPTIMUM DESIGN OF UNBRACED MULTI-STORY
FRAMES BY PLASTIC THEORY

by

Thomas M. Murray

Alexis Ostapenko

Reproduction of this report in
whole or in part is permitted for any
purpose of the United States Government.

Fritz Engineering Laboratory
Department of Civil Engineering
Lehigh University
Bethlehem, Pennsylvania

June 1966

Fritz Engineering Laboratory Report No. 273.42

T A B L E O F C O N T E N T S

	<u>Page</u>
ABSTRACT	1
INTRODUCTION	2
DISTRIBUTION OF LOAD SYSTEMS TO THE FRAME	4
ASSUMED MEMBER BEHAVIOR	6
THE WEIGHT FUNCTION	15
DESIGN OF MEMBERS	18
DIGITAL COMPUTER PROGRAM	19
CONCLUSIONS	24
ACKNOWLEDGEMENTS	26
APPENDIX I - EXAMPLE FRAME	27
APPENDIX II - COMPARISON WITH OTHER METHODS	29
APPENDIX III - COMPUTER PROGRAM DESCRIPTION	32
APPENDIX IV - NOMENCLATURE	55
FIGURES	57
REFERENCES	66

L I S T O F F I G U R E S

<u>Figure No.</u>		<u>Page</u>
1	Beam Mechanism	57
2	Horizontal Shear Equilibrium in a Story	57
3	Girders Subjected to Gravity Plus Sway Moments	58
4	Girders Having Plastic Moments in Clear Span	59
5	Frame Notation	59
6	Sketch of the Weight Function	60
7	Modified Weight Function	60
8	Moment Diagram for Combined Load	60
9	Bounded Weight Function	61
10	Two-Dimensional Weight Function	61
11	Flow Diagram for Determining Minimum Value of the Weight Function	62
12	Simplified Flow Diagram	63
13	Example Frame	64
14	Weight Comparison for Example Frame	65

L I S T O F T A B L E S

<u>Table No.</u>		<u>Page</u>
1	Member Sizes of Example Frame Designed by Plastic Method With Optimization	28
2	Member Sizes of Example Frame Designed by Allowable Stress Method	30
3	Member Sizes of Example Frame Designed by Plastic Method Without Optimization	31

L I S T O F D I S P L A Y S

A	FORTTRAN Program Statements	35
B	Data Specification	48
C	Sample Input Data	49
D	Sample Output Data	50

A B S T R A C T

A computer program is described which performs weight optimization of three-bay multi-story frames using plastic theory. The input consists of the frame geometry and the load intensity. The maximum number of stories depends only on the computer storage capacity. Three loading cases with corresponding load factors are considered: vertical loads only, vertical loads combined with lateral loads from the left, and vertical loads combined with lateral loads from the right. Loads are modified to include pertinent load reduction criteria. Where combined loads govern the size of members, the ratio of the capacities of individual members is determined by an iterative procedure using frame weight as the minimized function. Provision is made for consideration of second-order effects (P- Δ effects). The output of the program consists of the member forces needed for design of connections, and of member sizes. Refinement of the member sizes to account for frame instability and constructional details should be performed to complete the design.

Weight comparisons for a frame designed for allowable stresses and plastic theory without optimization are presented.

I N T R O D U C T I O N

At present, methods are not available to determine the ratios of individual member capacities in multi-story frames for greatest economy. When a structure is designed by plastic theory, redistribution of moments due to the successive formation of hinges is assumed.⁽¹⁾ This assumption permits the designer-analyst, when using plastic moment balancing, to specify within certain limits the member moments at any location in the frame without prior knowledge of the member capacities.⁽²⁾ This approach opens a way for optimum weight design of multi-story frames.

The adaptation of computers for optimization in the field of structural design has been limited. Attempts to apply linear programming have met with some success.⁽³⁾ However, the applications have been for very simple frames with only one set of loads.

The purpose of this paper is to describe a computer procedure developed for optimum weight design of unbraced three-bay, regular rectangular plane building frames using plastic theory. A regular rectangular plane frame is defined as one composed exclusively of horizontal girders and vertical columns, all column lines extending continuously from top to base without offset, and all girders lines extending continuously from one side of the frame to the other. The frame is assumed to be unbraced so that all resistance to lateral loads, sway, and frame instability is provided by rigid frame action, and all connections are assumed capable of developing plastic hinge moments in

the members. The maximum number of stories depends only on the computer storage capacity; bay widths and story heights may vary arbitrarily. A story is defined as a portion of a multi-story frame consisting of all girders on a level and the columns immediately below. Acceptable load systems may consist of area loadings, concentrated column loads, and lateral loads from either direction. Load-deflection ($P-\Delta$) effects may be included in the load system by increasing the lateral loads. The output gives member sizes and member forces needed for design of connections.

A brief description of the sequence of operations which the computer program performs is as follows: Vertical loads are applied to the structure and preliminary member capacities are determined. Combined lateral and vertical loads are then applied and, using the previous loading case as a parameter, a weight function, related to the cost of the frame, is minimized. The sequence of the application of lateral loads is reversed and the design operation repeated. All members are then designed for the most economical arrangement of beam and column capacities.

D I S T R I B U T I O N O F L O A D S Y S T E M S
T O T H E F R A M E

The distribution of the load system to the frame is assumed as follows:

1. Floor dead and live loads are distributed through the floor system to the girders as uniformly distributed line loads or as concentrated loads at the column lines.
2. Exterior wall dead loads are distributed to each bent as concentrated loads at connection points of spandrel beams.
3. Lateral loads of wind, earthquake, and as a measure of load-deflection moments are distributed to each bent as concentrated loads at the level of the girders.

The complete loading system consists of three loading cases: vertical loads only, vertical loads combined with lateral loads from the left, and vertical loads combined with lateral loads from the right. In each case live load reduction, is applied to the working loads before multiplication by the appropriate load factor. Load factors may vary arbitrarily at the discretion of the designer. (It has been suggested that a load factor of 1.7 be used for vertical loads and 1.3 for vertical loads combined with wind and earthquake).⁽⁴⁾

Live load reduction percentages as permitted by the American Standards Association Specification⁽⁵⁾ are calculated for each girder after the uniform dead and live floor loads are converted to equivalent

line loads per foot on the girder. These reductions are limited to the smallest of the three percentages:

1. 0.08 times the floor area served in square feet,
2. a formula based on the ratios of dead and live load,
3. 60 percent.

No reduction is permitted for roof girders, for areas where the live load is greater than 100 psf or where the tributary area of a floor associated with a girder is less than 150 square feet.

Column thrusts due to floor loads are calculated as if the floor spans were simply supported at the column center lines. Live load reduction percentages for each column are computed with the same limitations as stated for girders, except that a 20 percent reduction is allowed when the live load is greater than 100 psf. The sum of the weight of the exterior walls, and of the column and fireproofing in addition to the dead load of the floor spans is assumed to constitute the column dead load. Thus, the maximum reduction of 60 percent is applied to all but the uppermost column tiers.

A S S U M E D M E M B E R B E H A V I O R

For the vertical load case a beam mechanism is assumed to form under a uniformly distributed design ultimate load (factored working load). The span is taken equal to the distance between column center lines as shown in Fig. 1. The required plastic moment capacity is then given by:

$$M_p = F_1 w L^2 / 16 \quad (1)$$

where F_1 = load factor for vertical load case,

w = uniform working load (k/ft.),

L = girder span (c-c columns) (ft.).

Static equilibrium requires that the column be able to resist the girder end moment M_p . This moment is assumed to be distributed equally above and below the girder line, except in the case of roof girders where it must be applied to the column below. The column end moments obtained in this manner together with the factored column thrust are used to select a preliminary column. The reduced moment capacity, M_{pc} , of this section is used as a parameter in future loading cases.

When lateral loads are applied to the frame, the sum of the end moments of all columns in a story may be determined from an equilibrium equation based on the horizontal shear in the story. Figure 2 is a free body sketch of the columns in a story of a three bay frame. The total

horizontal shear, ΣH , which must be resisted by the columns is given by:

$$\Sigma H = \Sigma H_e + \Sigma H_w + \frac{\Sigma P \Delta}{h} \quad (2)$$

where

ΣH_e = a concentrated load equal to the sum of the external horizontal loads above the story due to earthquake loading.*

ΣH_w = a concentrated load equal to the sum of the external horizontal loads above the story due to wind loading,

$\frac{\Sigma P \Delta}{h}$ = a concentrated load equal to the horizontal component exerted by the sum of the column loads on the story acting in the displaced position resulting from the relative story sway,

Δ = relative story sway,

h = story height.

For preliminary design purposes the sum of the horizontal shears, ΣH , can be assumed to be applied at the girder line and the equilibrium imposed on undeformed columns. With all forces having a positive direction as shown in Fig. 2, the equilibrium equation is as follows:

$$\Sigma H + \Sigma M_c / h = 0 \quad (3a)$$

$$\text{or } \Sigma M_c = - h (\Sigma H) \quad (3b)$$

* It is not intended here to assume that plastic design is advanced sufficiently (1966) to include earthquake effects, but merely to indicate an approach for preliminary design purposes.

For equilibrium, the summation of the girder end moments at any level, must be equal to the summation of the column end moments joining these girders. It may be assumed that half of the moments in an average story occur at the top and half at the bottom of the columns. The total moment to be resisted by the girders at a particular level is then equal to the average of the sums of the column moments of the story above and the story below.

$$\Sigma M_g + \frac{1}{2} \left((\Sigma M_c)_{n-1} + (\Sigma M_c)_n \right) = 0 \quad (4)$$

where ΣM_g = the sum of the girder end moments at level n,

$(\Sigma M_c)_{n-1}$ = the sum of the column end moments above level n,

$(\Sigma M_c)_n$ = the sum of the column end moments below level n.

Substituting Eq. (3b) in Eq. (4) an expression for M_g is obtained in terms of story heights and horizontal shears

$$\Sigma M_g = \frac{1}{2} \left(((\Sigma H)h)_{n-1} + ((\Sigma H)h)_n \right) \quad (5)$$

If the girder end moments are known, the proportion of the story moment resisted by the column above can be determined from

$$\frac{1}{2} (\Sigma M_c)_{n-1} = DF \Sigma M_g \quad (6)$$

where $DF = ((\Sigma H)h)_{n-1} / \left(((\Sigma H)h)_n + ((\Sigma H)h)_{n-1} \right)$

When lateral loads are applied to the structure, each girder must resist moments caused by gravity loads as well as the lateral load moments given in Eq. (5). Usually the load factor for the vertical load case is greater than the load factor used for the case of combined

vertical and lateral loads. The excess moment capacity of the girder can be used to resist the lateral girder moments. Figure 3a shows the moment diagram for a uniformly loaded girder. M_{pm} is defined as the minimum plastic moment required to resist the working gravity loads multiplied by load factor F_2 , used for the combined load case:

$$M_{pm} = \frac{F_2 w L^2}{16} \quad (7)$$

The dashed lines in Fig. 3a represent the girder moment capacity, M_p , as obtained from the vertical load case. The unused bending capacity makes it possible for the girder to redistribute moments so that it can resist lateral load moments. Figure 3b shows the maximum redistribution possible without exceeding M_p . The maximum lateral moment which the girder can resist is then the algebraic sum of the clockwise girder moments.

$$M_g = M_p + M_{min} \quad (8)$$

If the girder capacity obtained in this manner is not sufficient to resist the sway moments, additional sway capacity can be realized if an effective load factor F_{1E} , greater than F_1 , is assumed. Figures 3c and d show two moment diagrams possible with larger girders. In Fig. 3d the second plastic hinge forms at the left hand end and therefore is the limiting case. For all values of M_g greater than that shown in Fig. 3d the moment diagram will appear to be the same but with larger values of actual M_p .

It should be noted in the sequence of moment diagrams in Fig. 3 that 1) the parabolic portion of the moment diagram due to the uniformly distributed load, $F_2 w$, always has the same relative configuration and size, 2) the location of the second plastic hinge is variable and moves from the center of the span to the left hand end, 3) the moment M_{\min} gradually changes from a maximum counterclockwise moment to a maximum clockwise moment.

Figure 4 shows two free body diagrams for a uniformly loaded girder. (6)

In Figure 4a:

$$\Sigma M_A + \downarrow = 0$$

$$V_B = \frac{F_2 w L}{2} + \frac{(A+1)M_P}{L} \quad (9)$$

In Figure 4b:

$$\Sigma F_y + \downarrow = 0$$

$$V_B = F_2 w x \quad (10)$$

$$\Sigma M_O + \downarrow = 0$$

$$V_B = \frac{F_2 w x}{2} + \frac{2M_P}{x} \quad (11)$$

Equating Eq. (10) and Eq. (11),

$$x = \sqrt{\frac{4M_P}{F_2 w}} \quad (12)$$

Substituting into Eq. (10),

$$V_B = F_2 w \sqrt{\frac{4M_P}{F_2 w}} \quad (13)$$

From Eq. (9)

$$(A+1) M_P = 2L \sqrt{F_2 w M_P} - \frac{F_2 w L^2}{2} \quad (14)$$

Substituting the value of M_P from Fig. 3c or 3d,

$$(A+1) = \frac{8F_2}{F_1} \left(\sqrt{\frac{F_{1E}}{F_2}} - 1 \right) \quad (15)$$

Since

$$(A+1) M_P = M_{\min} + M_P, \quad (16)$$

Equation (8) becomes,

$$M_g = \frac{8F_2}{F_{1E}} \left(\sqrt{\frac{F_{1E}}{F_2}} - 1 \right) M_P \quad (17)$$

If $F_{1E} = 4F_2$ then, $M_g = 2M_P$ which is the limiting case shown in Fig. 3d. The sway resistance of a loaded girder in terms of the load factors can be expressed by two equations:

$$M_g = 8F_2 \left(\sqrt{\frac{F_{1E}}{F_2}} - 1 \right) \frac{wL^2}{16}, \quad F_2 \leq F_{1E} \leq 4F_2 \quad (18a)$$

$$M_g = 2 F_{1E} \frac{wL^2}{16} = F_{1E} \frac{wL^2}{8}, \quad 4F_2 \leq F_{1E} \quad (18b)$$

The total capacity of the girders on a particular level to resist sway moments is the summation of the sway capacity of each individual girder. It is not necessary for the effective load factor, F_{1E} , to be the same for all girders.

For a certain number of levels below the roof, the girder capacity will be controlled by gravity load alone at load factor F_1 . The total moment capacity of gravity controlled girders on a level is given by

$$\Sigma M_g = 8F_2 \left(\sqrt{\frac{F_1}{F_2}} - 1 \right) \Sigma \frac{wL^2}{16} \quad (19)$$

Comparison of Eq. 19 with the required moment capacity given by Eq. 5 will determine for which level gravity load no longer controls the girder design.

Consideration of a symmetric three-bay frame symmetrically loaded shows that under gravity loads the interior columns theoretically are not required to resist any moment. However, with lateral loads applied the interior columns must exhibit some moment capacity. Thus, sufficient girder moment capacity does not insure sufficient frame capacity to resist lateral loads. The distribution of the sway moments at a level for economy is dependent on the column moment capacities from the vertical load case.

At levels where the excessive girder capacity from the vertical load case is not sufficient to resist sway moments an effective load factor, F_{1E} , can be assumed for two bays and the load factor required for the third bay calculated.

Using the notation of Fig. 5 and assuming effective load factors for spans AB and BC the sway resistance girder capacity of these bays at level n is given by:

$$M_{gA-C} = K_{AB} \frac{w_{AB} L_{AB}^2}{16} + K_{BC} \frac{w_{BC} L_{BC}^2}{16} \quad (20)$$

$$\text{where } K = 8F_2 \left(\sqrt{\frac{F_{1E}}{F_2}} - 1 \right) \quad 0 \leq F_{1E} \leq 4F_2$$

$$\text{or } K = 2F_{1E}, \quad 4F_2 \leq F_{1E}$$

The required sway moment capacity of span CD is

$$M_{gCD} = (F_2 \sum M_c)_n - M_{gA-C} \quad (21)$$

The load factor for span CD is obtained by solving Eqs. 18a and 18b

for F_{1E} .

$$(F_{1E}) = \left(1.0 + \frac{K_{CD}}{8F_2} \right) 2F_2, \quad 0 \leq K_{CD} \leq 8F_2 \quad (22a)$$

$$(F_{1E})_{CD} = \frac{K_{CD}}{2}, \quad 8F_2 < K_{CD} \quad (22b)$$

where

$$K_{CD} = \frac{M_{gCD}}{\frac{wL_{CD}^2}{16}}$$

The column end moments can then be found by using Eq. 6 and equations of equilibrium at each joint.

As a result of the assumption that half of the moments in an average story occur at the top and half at the bottom of the columns, each level can be designed independently and various combinations of girder capacities can be investigated readily without complete reanalysis of the entire frame. It is then possible to calculate the weight, as a measure of the cost of the frame for each combination and select the case with minimum weight for the final design.

T H E W E I G H T F U N C T I O N

It is assumed here that the weight of a member is proportional to its moment capacity. Thus, a weight function is defined in terms of the maximum required moment capacity and the length of each column and girder in a story.*

$$Wt = h \sum (M_{cmax}) + \sum (M_{gmax} L_g) \quad (23)$$

where M_{cmax} = the maximum required moment capacity of a column,

h = story height,

M_{gmax} = the maximum required moment capacity of a girder,

L_g = girder length.

Substituting Eq. 6, 18, and 22 into Eq. 23 the weight function is expressed in terms of $(F_{1E AB})$ and $(F_{1E BC})$. Figure 6 is a sketch of the general shape of the resulting function.

If the moment capacity for any previous loading of any member is greater than the moment capacity for the distribution being considered its value is substituted in Eq. 23. This substitution tends to flatten the shape of the weight function as shown in Fig. 7.

*A more accurate expression for the weight function is

$$Wt. = h \sum \frac{M_{cmax}}{d_c} + \sum \frac{M_{gmax}}{d_g} L_g$$

where d_c and d_g are the depths of columns and girders, respectively.

It can be concluded from Fig. 6 and 7 that a unique minimum value exists. Minimization of the weight function in Fig. 6 will lead to the most economical arrangement of girder and column moment capacities for a particular loading case. Minimization of the weight function in Fig. 7 will lead to the most economical arrangement for a sequence of loadings since member capacities required in previous loading cases are considered.

The dashed lines in Fig. 8 represent the moment capacities of the members obtained from a previous loading case. The minimum value of the weight function will have the tendency to distribute moments in a manner which will utilize available capacity. The solid lines represent the moment diagram for an applied sway moment just equal to the given girder capacities. As the sway moment is increased the additional moment will be distributed in the following order of preference:

1. To the shortest girder span if the adjacent columns have excess moment capacity.
2. To the girder span where excess column moment capacity exists.
3. To the shortest span.

If additional sway moment is applied to the story in Fig. 8, analysis of the weight function shows that the additional moment will be taken by the girder in span BC until the moment capacities of columns B and C are exceeded. Any additional moment will be taken by span AB until the capacity of column A is exceeded. Further moment will be

distributed to span BC only, for economy. For tall frames it can be seen that the required girder size for span BC of Fig. 8 can be quite large and that the distribution of moments for a practical design may not be the most economical as determined from the weight function. The assumption of maximum values for the effective load factors will not affect the shape of the weight function, but it will reduce the validity of the weight function to the portion bounded by these maximum load factor values. This is shown graphically in Fig. 9.

It is possible then for the designer to analyze the frame under vertical loads only, and using the maximum moment capacities for all members as parameters, apply lateral loads from the left and determine the most economical arrangement of the member capacities from the weight function. Lateral loads from the right can then be applied, and using the previous loading cases as a parameter a new distribution determined. A different sequence of loadings--vertical, lateral loads from the right, lateral loads from the left--may result in a different distribution of moment capacities. The two designs can be compared and the most economical arrangement used for the final preliminary design. This approach may not result in the most economical arrangement possible, but it is judged to be fully adequate for design purposes.

D E S I G N O F M E M B E R S

Member sizes are chosen for member forces obtained by the procedure described above. Members are assumed to be adequately braced to preclude out-of-plane and lateral-torsional instability.

When the interaction of bending moment and axial force is considered, the approximate end moment capacity of a column is taken to be

$$M_{pc} = M_p \quad \text{when } P/P_y \leq 0.15 \quad (24a)$$

$$M_{pc} = 1.18 (1 - P/P_y) M_p \quad \text{when } 0.15 \leq P/P_y \leq 1.0 \quad (24b)$$

where M_{pc} = plastic hinge moment modified to include the effect of axial compression,

P = concentrated axial load,

P_y = axial load corresponding to yield stress level: $P = A \cdot F_y$,

M_p = $Z \cdot F_y$ = plastic moment capacity of the section,

Z = plastic section modulus.

This is in accordance with the present AISC Specification⁽⁷⁾ for plastic design and is valid for columns subjected to double curvature bending. The approximation is acceptable for the purpose of preliminary design since, except for a few upper stories, the critical column design condition is when the frame is subjected to combined vertical and lateral loads and columns are in double curvature bending.

Girder sizes are selected from section economy tables using the required member end capacities with consideration given to maximum depths for architectural reasons.

D I G I T A L C O M P U T E R P R O G R A M

A digital computer program for a General Electric 225 computer has been developed to handle the extensive calculations involved in the method described in the previous sections. The program is written in the FORTRAN II language and consists of a main routine and five sub-routines. Running time on the GE 225 can be estimated at one half minute per story excluding the start up time. A brief description of the program is as follows:

Input data:

1. Frame Geometry:

Bent spacing

Span lengths

Parapet wall and story heights

Number of stories

2. Load System

Area dead and live loads

Weight of exterior walls

Estimated weight of columns plus fireproofing

Area lateral loads

Number of stories for which the magnitude of each load

is applicable

3. Miscellaneous:

Load factors for each loading case

Yield stresses of the steel to be used

Maximum effective load factors

Maximum depth of girders

Section properties needed for girder and column design.

Area loads are converted to uniform girder loadings and to column thrusts. Live load reduction allowed by the ASA 58.1⁽⁵⁾ specification is applied to all loadings. Girder working load end moments and shears are computed and printed for reference. Lateral loads are converted to concentrated loads at the girder lines.

Using the load factor for the vertical load case, factored girder and column end moments, girder end shears, and column thrusts are calculated and printed. Equations (24a) and (24b) together with the factored column moments and thrusts are used to select preliminary column sizes from a list of suitable wide flange sections.

Next, the sum of the girder end moments, ΣM_g , required to resist the factored overturning moments of the lateral loads from the left are determined at the roof level (Eq. 3). An effective load factor $F_{1E} = F_1$ is assumed for span AB. With one variable, $(F_{1E})_{AB}$, equal to a constant the weight function becomes a two dimensional curve shown in Fig. 11. Since the effective load factor for span CD can be expressed as a function of the effective load factors for spans AB and BC (Eq. 22) any point on the curve can be determined by assuming a value for $(F_{1E})_{BC}$.

The maximum moment capacities required for the columns and girders from either load case are used in evaluating the weight function.

The minimum point on the curve is found using the procedure shown in the flow diagram in Fig. 11. The largest effective load factor, $(F_{1E})_{\max}$, may be selected by the designer to limit the size of girders. The trial load factor F is assumed equal to the average of F_{\min} and F_{\max} and the slope of the curve in the region of F is determined by evaluating the weight function at F and at $F + 0.001$. If the slope is negative, $F_{\min} = F$. If the slope is positive, $F_{\max} = F$. The procedure is then repeated using the new value of F_{\min} or F_{\max} . When the values of F_{\min} and F_{\max} are within 0.1, $Wt(1)$ is assumed to be the minimum value.

$(F_{1E})_{AB}$ is then incremented and a new minimum value for the weight function is found. This value is then compared to the previous value. If the new value is larger the procedure stops and a complete moment balance is performed using the load factors from the previous trial. If the new value is smaller, the procedure is continued until a larger value is found.

Using column moments obtained from the moment balance and the appropriately factored column thrusts, the column sections selected from the vertical load case are checked and if found inadequate new sections chosen.

The same procedure is then carried out for each successive story, and member end moments, girder shears, and column thrusts are printed for reference.

The direction of the lateral load is reversed and the weight function is again minimized for each story successively beginning at the roof. The maximum moment capacity of each member, as determined from previous loading cases or as required by the case under consideration, is used for determining the value of the weight function at each point along the curve for each story. Factored member end moments, girder shears and column thrusts are printed at each level.

Using the largest required moment capacity from any of the loadings, final girder sections are selected from a complete list of available shapes. Final column and girder sizes and the total weight of the frame are printed.

The procedure is repeated with the second loading sequence: vertical loads, vertical loads combined with lateral loads from the right, and finally vertical loads combined with lateral loads from the left. The weights of the two frames are compared and the configuration having the minimum weight is selected as the final preliminary design.

A simplified flow diagram of the program is shown in Fig. 12. This diagram essentially follows the outline given above and no additional explanation is deemed necessary. An example design of a twenty-four story three-bay frame is included in Appendix I. This is the same frame as was designed in Refs. 4, 8, and 9. Comparison of this design with preliminary and final designs of the frame using allowable-stress design and plastic theory without optimization are presented in Appendix II.

Comparison of the three designs in Appendices I and II shows that the weight optimization procedure will result in a significant reduction in the cost of unbraced multi-story frames. The computer program can be used not only to speed up the design, but also to produce a design more economical than by any other method available.

C O N C L U S I O N S

A computer program was devised for the optimum design of unbraced multi-story frames using plastic theory. This program is applicable to three-bay frames of any number of stories, but without missing members. The basic theory of the method is valid for any number of bays. However, the approach used to determine the minimum value of the weight function must be modified since each additional bay adds an additional dimension to the function. Operations Research or non-linear programming may be used for this purpose.

Comparison of the design of an example frame using the optimization procedure shows weight savings of 12.8% over the allowable stress method and 6.7% over the plastic method without optimization.

Further improvements of the program which are desirable and feasible include: 1) use of clear span for girder design, 2) more accurate column design method for upper stories where columns are not in double curvature bending, 3) inclusion of the depth of members in the weight function, 4) refinement of the weight function to include the already selected girders on a level when determining the third girder, 5) inclusion of P- Δ effect, 6) methods for handling multi-bay frames, 7) consideration of working load deflections.

When the sway subassemblage method of column design* described in Ref. 10 was used to check the member sizes shown in Table 1. It was found that member sizes in all but the uppermost stories are suitable for a final design. Deflection checks show that the addition of a horizontal force equal to two percent of the girder dead and live loads at a level is too conservative for estimating the effect of P- Δ moments.⁽¹¹⁾ A one percent horizontal force would produce deflections which more closely approximate those predicted by the subassemblage method of design.

The results of the program are to be considered as preliminary and could be used as input data for programs which make deflection estimates or check the stability of the frame as needed for final design.

* This semi-graphical method is considered at present (1966) to be the most rigorous for plastic design of multi-story frames. P- Δ effects are included and the maximum strength of the structure, even though it may occur before the formation of a mechanism, is considered.

A C K N O W L E D G E M E N T S

The work described in this report was conducted in Fritz Engineering Laboratory of the Department of Civil Engineering, Lehigh University, Bethlehem, Pennsylvania. Professor William J. Eney is Head of the Department and the Laboratory and Professor Lynn S. Beedle is Director of the Laboratory.

Funds for typing and reproduction of this manuscript was provided by the Department of Civil Engineering, Lehigh University project "Plastic Design of Multi-Story Frames" sponsored jointly by Welding Research Council, American Iron and Steel Institute, American Institute of Steel Construction, and the United States Navy. Recognition is given to the assistance and computer time provided by the Lehigh University Computer Center. The manuscript was typed with care by Miss M. L. Courtright.

A P P E N D I X I
E X A M P L E F R A M E

The twenty-four story three-bay frame in Fig. 13 is used to illustrate the method. This is the same frame as was designed in Ref. 4 and 9.

Dead loads are based on assumed weights for 5-in. reinforced concrete slabs, plaster ceilings, fireproofing, and the weight of steel system members. A constant wind pressure was assumed. A horizontal force, equal to two percent of the girder dead and live loads at a level, was added to the wind force at each level to include the effect of $P-\Delta$ moments. (The total wind pressure in the design was 37.9 psf, which included $P-\Delta$ effects).

For the sake of comparison with designs in Ref. 4 and 9, A-36 steel was used for all girders and for all columns above the eleventh level. A-441 steel was used for the remaining column sections..

Maximum effective load factors of 5.5, 19.5, 5.0 were assumed for Bay AB, Bay BC, and Bay CD, respectively. Additional reduction in the weight of the girders could be obtained if larger effective load factors had been assumed in Bays AB and BC.

Table 1 shows final girder end column sections together with weight tabulations.

Columns

Tier	Col A	Col B	Col C	Col D
1-3	12WF 40	10WF 39	14WF 53	14WF 61
3-5	14WF 61	14WF 53	14WF 78	14WF 84
5-7	14WF 84	14WF 78	12WF106	14WF111
7-9	12WF106	12WF106	14WF136	14WF136
9-11	14WF127	14WF127	14WF158	14WF167
11-13	(14WF119)	(14WF136)	(14WF150)	(14WF150)
13-15	(14WF142)	(14WF176)	(14WF176)	(14WF176)
15-17	(14WF167)	(14WF211)	(14WF202)	(14WF193)
17-19	(14WF190)	(14WF264)	(14WF264)	(14WF211)
19-21	(14WF211)	(14WF314)	(14WF314)	(14WF246)
21-23	(14WF246)	(14WF314)	(14WF370)	(14WF264)
23-25	(14WF287)	(14WF342)	(14WF398)	(14WF287)

Girders

Level	Bay AB	Bay BC	Bay CD
1	16B26	10B15	18WF45
2	16WF36	14B17.5	18WF55
3	do	do	do
4	do	12B22	21WF55
5	16WF40	do	do
6	16WF45	14B26	do
7	do	14WF30	12WF62
8	18WF45	16WF36	do
9	do	16WF40	do
10	16WF50	18WF45	21WF68
11	do	21WF55	do
12	do	21WF62	do
13	do	24WF68	do
14	21WF55	24WF76	21WF62
15	21WF68	do	21WF55
16	do	27WF84	do
17	24WF68	do	do
18	do	27WF94	do
19	24WF76	do	do
20	do	do	21WF55
21	do	do	21WF62
22	do	do	24WF68
23	do	do	24WF94
24	do	do	27WF94

Weight
A36 and A441 Steel

	A36	A441
Girder Wt.	40.3 T	--
Column Wt.	22.9 T	76.0 T
Total Wt.	63.2 T	76.0 T

(Columns in parenthesis)

Table 1 Member Sizes of Example Frame Designed by Plastic Method With Optimization

A P P E N D I X I I
C O M P A R I S O N W I T H O T H E R M E T H O D S

Tables 2 and 3 show the final column and girder sizes for the example frame of Appendix I designed by allowable-stress method and by plastic method without optimization.⁽⁹⁾ The load assumptions, including the horizontal force to produce the effect of P- Δ moments, and the choice of steel were the same as for the frame of Appendix I.

Figure 14 shows graphically a comparison of girder weight, column weight and total weight of the frame by the three design methods. A savings of 12.8% can be realized using the proposed method over allowable-stress design and 6.7% over the plastic design method without optimization.

It is to be noted that the comparison of the design example of Appendix I and the design using plastic method without optimization (Table 3) would be more favorable if clear span were used in the design example. This assumption was used to obtain the girder sections in Table 3, and it reduces the required moment capacity (and weight) for girders with a slight increase in the required moment capacity of the columns.

COLUMNS

Tier	Col A	Col B	Col C	Col D
1-3	14WF 48	14WF 40	12WF 58	14WF 61
3-5	14WF 68	14WF 61	14WF 87	14WF 95
5-7	14WF 87	14WF 84	14WF119	14WF119
7-9	14WF127	14WF119	14WF150	14WF158
9-11	14WF150	14WF142	14WF176	14WF184
11-13	(14WF150)	(14WF142)	(14WF176)	(14WF193)
13-15	(14WF184)	(14WF158)	(14WF193)	(14WF246)
15-17	(14WF211)	(14WF176)	(14WF211)	(14WF287)
17-19	(14WF264)	(14WF193)	(14WF264)	(14WF314)
19-21	(14WF287)	(14WF237)	(14WF287)	(14WF370)
21-23	(14WF314)	(14WF246)	(14WF314)	(14WF298)
23-25	(14WF370)	(14WF287)	(14WF342)	(14WF458)

GIRDERS

Level	Bay AB	Bay BC	Bay CD
1	14WF34	12B16.5	18WF55
2	16WF45	16B26	21WF62
3	do	14WF30	do
4	do	14WF34	do
5	do	16WF36	do
6	16WF50	do	21WF68
7	18WF50	16WF40	24WF68
8	18WF55	16WF45	24WF68
9	21WF55	18WF45	24WF76
10	21WF62	16WF50	24WF84
11	do	18WF50	do
12	21WF68	do	27WF84
13	24WF68	18WF55	24WF94
14	do	21WF55	27WF94
15	24WF76	21WF62	do
16	do	do	30WF99
17	24WF84	21WF68	do
18	do	do	30WF108
19	27WF84	do	do
20	24WF94	24WF68	30WF116
21	27WF94	do	do
22	do	do	33WF118
23	do	24WF76	do
24	30WF99	do	do

WEIGHT

A36 and A441 Steel

	A36	A441
		(Columns in Parenthesis)
Girder Wt. =	50.2 T	--
Column Wt. =	24.5 T	85.0 T
Total Wt. =	74.7 T	85.0 T

Table 2 Member Sizes of Example Frame Designed by Allowable-Stress Method

COLUMNS

Tier	Col A	Col B	Col C	Col D
1-3	12WF 40	12WF 40	12WF 58	12WF 58
3-5	12WF 58	12WF 58	12WF 79	12WF 79
5-7	14WF 78	14WF 78	14WF111	14WF111
7-9	14WF111	14WF111	14WF136	14WF136
9-11	14WF127	14WF127	14WF158	14WF158
11-13	(14WF136)	(14WF142)	(14WF193)	(14WF158)
13-15	(14WF142)	(14WF167)	(14WF211)	(14WF184)
15-17	(14WF167)	(14WF193)	(14WF246)	(14WF202)
17-19	(14WF211)	(14WF237)	(14WF314)	(14WF246)
19-21	(14WF246)	(14WF264)	(14WF342)	(14WF287)
21-23	(14WF287)	(14WF314)	(14WF370)	(14WF314)
23-25	(14WF314)	(14WF342)	(14WF398)	(14WF320)

GIRDERS

Level	Bay AB	Bay BC	Bay CD
1	14B26	12Jr11.8	16WF45
2	16WF36	12B16.5	18WF55
3	do	do	do
4	do	do	do
5	do	16B31	do
6	16WF45	16WF40	do
7	do	do	do
8	18WF50	18WF50	do
9	do	do	do
10	21WF55	21WF55	21WF55
11	do	do	do
12	21WF62	21WF62	21WF62
13	do	do	do
14	21WF68	21WF68	21WF68
15	do	do	do
16	24WF68	24WF68	24WF68
17	do	do	do
18	24WF76	24WF76	24WF76
19	do	do	do
20	do	do	do
21	24WF84	24WF84	24WF84
22	do	do	do
23	do	do	do
24	27WF84	27WF84	27WF84

WEIGHT

A36 and A441 Steel

	A36	A441 (Columns in Parenthesis)
Girder Wt.	= 42.8 T	
Column Wt.	= <u>23.0</u> T	<u>83.4</u> T
Total Wt.	= 65.8 T	83.4 T

Table 3 Member Sizes of Example Frame Designed by Plastic Method Without Optimization

A P P E N D I X I I I
C O M P U T E R P R O G R A M D E S C R I P T I O N

F O R T R A N S t a t e m e n t s

The complete listing of the FORTRAN II program described in this paper is shown in Display A. Sufficient explanation has been added to enable the designer, who is expected to be familiar with the FORTRAN language, to follow the logic of the program.

The core storage capacity of the GE 225, the computer for which the program was developed, was not sufficient to permit the storage of the entire program and the necessary data. A system called CHAIN was used to alleviate this deficiency. CHAIN permits the storage of sections of a program on magnetic tape. Each section or "link" is placed in core storage as required for execution of the program. Values of the variables assigned to COMMON storage are not affected by the execution of individual links. Several changes in the program statements are necessary if sufficient core capacity is available to store the program in its entirety (about 10,000 locations). These revisions have been noted in Display A.

The program can also be modified for designing a frame of any number of stories by changing the array specifications following the COMMON and DIMENSION statements.

Data Preparation

The input data is arranged in the following manner:

1. Frame number (must be positive if the program is to be executed).
2. Frame geometry
3. Area loadings
4. Weight of exterior walls and columns plus fireproofing
5. Wind pressure
6. Load factors
7. Column section properties (83 sections are required in order of increasing weight).
8. Yield points of steel to be used for column design (not more than three).
9. Maximum effective load factors for girder design.
10. Girder section properties (221 sections required in order of increasing weight).
11. Yield points of steel to be used for girder design (not more than three).
12. Maximum girder depths.
13. Frame number (negative to stop the program).

The number of stories for which each piece of data is applicable is also included as input. Linear measurements are assumed to be in feet; area loadings, weight of exterior walls, and wind pressure in pounds per square foot; weight of columns plus fireproofing in pounds per foot. Column and girder section properties required are: nominal depth, in., weight, lb/ft.; plastic section modulus, in.³

The program is organized in such a manner as to allow the designer, at his discretion, to vary the story height and items 3, 4, 5, 9, and 12 at each story. The maximum number of steel yield points (items 8 and 11) which may be used in a given design is three for columns and three for girders. However, if the input data for the yield point of columns is 441.0, the program will consider the first 56 columns at a yield point of 50.0 ksi, the next 12 at 46.0 ksi, and the last 15 at 42.0 ksi. These stresses correspond to the yield points allowed by the AISC Specification for A441 steels.⁽⁷⁾

Display B lists the order of the input data and gives the acceptable FORMAT. Display C shows a set of data cards for a ten story frame. Display D shows part of the output for the data of Display C.

```

C      PRELIMINARY PLASTIC DESIGN OF MULTI-STORY-THREE-BAY FRAMES
C      BY T.M. MURRAY, LEHIGH UNIVERSITY
C
C      SPECIFICATION OF ARRAY DIMENSIONS
COMMON  A[3],B[3],ALL[4],ALLOW[4],D[3],E[3],F[3],FW[3],G[14]
COMMON  GM[25,3],H[25],P[25,3],R[4],RC[4],SUMA[4],SUMLL[4]
COMMON  SUMRL[4],ST[4],XL[3],T[25,7],V[6],WDL[3],WL[25],WLL[3]
COMMON  AA,BS,COL,DF,F1,F2,FY,F1MAX,GIRCAP,GIRREQ,GMC,GMC1,I,J,JJ
COMMON  K,NN,NS,PWH,W,WALL,WEIGHT,WINC,WIND,WTMN1,WTMN2,X,XCOL
COMMON  ID[92],W[92],Z[92],ICOL[25,4],KK,LC
COMMON  SUMWT,SPEC[3],NSPEC[3],TEMPWT
EQUIVALENCE [W[1],PY[1]], [Z[1],XMP[1]], [T[101],SV[1]]
EQUIVALENCE [WL[1],WLM[1]]
DIMENSION PY[92],XMP[92],WST[3],SV[25,3],WLM[25]
C      INPUT FRAME NUMBER AND EXIT IF NEGATIVE
      1 READ 100 ,NN
100  FORMAT (I10)
      IF (NN)2,3,3
      2 CALL EXIT
C      INPUT/OUTPUT FRAME GEOMETRY (ALL DIMENSIONS IN FT.)
      3 READ 101,NS,BS,[XL[K],K=1,3],PWH
101  FORMAT (I10,4F10.2/F10.2)
      PRINT 102,NN,NS,BS
102  FORMAT (63H1 PRELIMINARY PLASTIC DESIGN OF MULTI-STORY-THREE BAY
1  FRAME NO.,I5///7X,14HFRAME GEOMETRY//
2  220H NUMBER OF STORIES,,I4// 15H BENT SPACING,,F 6.2,4H FT.//)
      PRINT 135,[XL[K],K=1,3],PWH
135  FORMAT (23H SPAN LENGTHS, BAY AB,F6.2,4H FT./
1  17X, 6HBAY BC,F6.2,4H FT./
2  17X, 6HBAY CD,F6.2,4H FT.//
3  30H STCRY HEIGHTS, PARAPET WALL,F15.2,4H FT.)
      KJ=0
      JJ=0
      DO 90 K=1,4
      SUMRL[K]=0.0
90  SUMA[K]=0.0
      DO 48 I=1,NS
      IF ([I-JJ]49,49,50
50  READ 133,H[I],J
133  FORMAT (F10.2,I10)
      JJ=JJ+J
      PRINT 134,I,JJ,H[I]
134  FORMAT (17X, 8H STORIES,I6,4H TO ,I3,F7.2,4H FT.)
      GO TO 48
49  H[I]=H[I-1]
48  CONTINUE
C      INPUT WORKING DEAD AND LIVE LOADS, NO. OF LEVELS APPLICABLE
      PRINT 136
136  FORMAT (20H1 WORKING LOADS//7X, 16HA. GIRDER LOADS/
1  11X, 38H[PER CENT LIVE REDUCTION BY ASA A58.1]///
2  13H ROCF GIRDER, 27X,22HBAY AB BAY BC BAY CD]
      DO 45 K=1,3
      A[K]=BS*XL[K]
45  ALL[K]=A[K]/20.

```

```

JJ=0
AA=BS/10.
DO 21 I=1,NS
IF [I-JJ]17,17,16
16 READ 121,(WLL[K],WDL[K],K=1,3),J
121 FORMAT [6F10.2,I10]
JJ=JJ+J
C      OUTPUT WORKING LOADS
      IF [I-1]4,4,5
      5 PRINT 110,I,JJ
110 FORMAT [ 9H LEVELS ,I3,4H TO ,I3]
      4 PRINT 111,[WLL[K],K=1,3] , [WDL[K],K=1,3]
111 FORMAT [31H0 WORKING LIVE LOAD, LB./SQ.FT.,7X      ,3F8.2/
      1      31H WORKING DEAD LOAD, LB./SQ.FT.,7X      ,3F8.2]
      DO 7 K=1,3
      WLL[K]=WLL[K]*BS/1000.
      7 WDL[K]=WDL[K]*BS/1000.
      PRINT 113,[WLL[K],K=1,3]
113 FORMAT [26H WORKING LIVE LOAD, K/FT.,12X      ,3F8.2]
C      COMPUTE LIVE LOAD REDUCTION
      DO 8 K=1,3
      IF [I-1]9,9,10
      10 IF [WLL[K]-AA]11,11,9
      11 IF [A[K]-150.] 9,9,12
      12 R[K]=.08*A[K]
      ALLOW[K]=100.*([WDL[K]+WLL[K])/4.33/WLL[K]
      IF [R[K]-ALLOW[K]]13,13,14
      14 R[K]=ALLOW[K]
      13 IF [R[K]-60.]15,15,18
      18 R[K]=60.
      GO TO 15
      9 R[K]=0.00
      15 P[I,K]=[1.0-R[K]/100.]*WLL[K]
      8 CONTINUE
C      OUTPUT GIRDER LOADS
      PRINT 114,[R[K],K=1,3],[P[I,K],K=1,3],[WDL[K],K=1,3]
114 FORMAT [38H PER CENT REDUCTION OF LIVE LOAD      ,3F8.2/
      1      30H NET WORKING LIVE LOAD, K/FT.,8X      ,3F8.2/
      2      26H WORKING DEAD LOAD, K/FT. ,12X      ,3F8.2]
      DO 19 K=1,3
      19 P[I,K]=P[I,K]+WDL[K]
      PRINT 117,[P[I,K],K=1,3]
117 FORMAT [27H TOTAL WORKING LOAD, K/FT. ,11X      ,3F8.2 //]
      GO TO 46
      17 DO 20 K=1,3
      20 P[I,K]=P[I-1,K]
      46 DO 47 K=1,3
      T[I,K]=WDL[K]*XL[K]/2.
      47 T[I,K+4]=WLL[K]*XL[K]/2.
      21 CONTINUE
C      OUTPUT WORKING LOAD GIRDER MOMENTS AND SHEARS
      PRINT 118
118 FORMAT [36H1      B. GIRDER MOMENTS AND SHEARS//
      1 7H LEVEL,9X,7H MOMENTS,40X, 6HSHEARS/
      2 9X,22HBAY AB BAY BC BAY CD, 14X,6HBAY AB,12X,6HBAY BC,

```

```

3 12X, 6HBAY CD)
DO 22 I=1,NS
DO 23 K=1,3
V[2*K]=P[I,K]*XL[K]/2.
V[2*K-1]=-V[2*K]
23 P[I,K]=V[2*K]*XL[K]/8.
22 PRINT 120,I,[P[I,K],K=1,3],[V[K],K=1,6]
120 FORMAT [I7,3F8.1,5X,3[F10.1,F8.1]]
C      INPUT WEIGHT OF EXTERIOR WALLS, COLUMNS, AND FIREPROOFING
C      OUTPUT SAME
PRINT 129
129 FORMAT [25H1      C. COLUMN THRUSTS///
1 8H LEVELS,7X,9HDEAD LOAD,11X,19HESTIMATED DEAD LOAD/
2 12X,14HEXTERIOR WALLS,7X,24HOF COLUMN + FIREPROOFING//]
C      CALCULATE DEAD LOAD COLUMN THRUSTS
JJ=0
DO 41 I=1,NS
IF [I-JJ] 43,43,42
42 READ 127, WALL,COL,J
127 FORMAT [2F10.2,I10]
JJ=JJ+J
PRINT 130,I,JJ,WALL,COL
130 FORMAT [I4,4H TC ,I3,F9.2,4H PSF,F20.2,6H LB/FT]
43 T[I,4]=T[I,3]
XCOL=H[I]*COL/1000.
IF [I-1] 52,52,53
52 T[1,3]=T[1,3]+T[1,2]+XCOL
T[1,2]=T[1,2]+T[1,1]+XCOL
T[1,1]=T[1,1]+XCOL+PWH*WALL*BS/1000.
T[1,4]=T[1,4]+XCOL+PWH*WALL*BS/1000.
GO TO 41
53 T[I,3]=T[I-1,3]+T[I,3]+T[I,2]+XCOL
T[I,2]=T[I-1,2]+T[I,1]+XCOL+T[I,2]
DO 54 K=1,4,3
54 T[I,K]=T[I-1,K]+T[I,K]+XCOL+H[I-1]*XWALL
41 XWALL=WALL*BS/1000.
C      CALCULATE TOTAL COLUMN LOAD INCLUDE LIVE LOAD REDUCTION
DO 60 I=1,NS
IF [I-1] 61,61,62
61 T[1,1]=T[1,1]+T[1,5]
SUMLL[1]=T[1,5]
T[1,4]=T[1,4]+T[1,7]
SUMLL[4]=T[1,7]
DO 63 K=2,3
T[1,K]=T[1,K]+T[1,K+3]+T[1,K+4]
63 SUMLL[K]=T[1,K+3]+T[1,K+4]
GO TO 60
62 DO 64 K=1,4
GO TO [65,66,66,67],K
65 IF [T[I,5]-ALL[1]]68,68,69
68 SUMRL[1]=SUMRL[1]+T[I,5]
SUMA[1]=SUMA[1]+A[1]/2.
GO TO 75
69 SUMLL[1]=SUMLL[1]+.80*T[I,5]
GO TO 72

```

```

67 IF [T[I,7]-ALL[3]]73,73,74
73 SUMRL[4]=SUMRL[4]+T[I,7]
   SUMA[4]=SUMA[4]+A[3]/2.
   GO TO 75
74 SUMLL[4]=SUMLL[4]+.80*T[I,7]
   GO TO 72
66 IF [T[I,K+3]-ALL[K-1]] 79,79,80
80 SUMLL[K]=SUMLL[K]+.80*T[I,K+3]
   GO TO 87
79 SUMRL[K]=SUMRL[K]+T[I,K+3]
87 IF [T[I,K+4]-ALL[K]] 81,81,86
86 SUMLL[K]=SUMLL[K]+.80*T[I,K+4]
   GO TO 85
81 SUMRL[K]=SUMRL[K]+T[I,K+4]
85 IF [RC[K]-.60] 84,72,72
84 SUMA[K]=SUMA[K]+[A[K-1]+A[K]]/2.
   GO TO 82
75 IF [RC[K]-.60] 82,72,72
82 IF [SUMA[K]-120.] 70,70,71
70 RC[K]=0.0
   GO TO 72
71 RC[K]=.0008*SUMA[K]
   ALLOW[K]=[SUMRL[K]+T[I,K]]/4.33/SUMRL[K]
   IF [RC[K]-ALLOW[K]] 76,76,77
77 RC[K]=ALLOW[K]
76 IF [RC[K]-.60] 72,72,78
78 RC[K]=.60
72 T[I,K]=T[I,K]+SUMLL[K]+[1.0-RC[K]]*SUMRL[K]
64 CONTINUE
60 CONTINUE

```

C

OUTPUT COLUMN THRUSTS

```

PRINT 128
128 FORMAT [///41H0 GRAVITY LOADS IN COLUMNS OF FRAME BASED/
1 8X, 27H0N TRIBUTARY AREA OF FLOORS/
2 10X, 23H(WORKING LOADS IN KIPS)]/
3 44H STORY COL A COL B COL C COL D//]
PRINT 140, [I,[T[I,K],K=1,4],I=1,NS]
140 FORMAT [I7,F10.1,3F9.1]

```

C

INPUT WIND PRESSURE/OUTPUT WIND SHEARS

```

PRINT122
122 FORMAT [32H1 D. WIND LOADS AND SHEARS//
115H WIND PRESSURE]
JJ=0
DO 24 I=1,NS
IF [I-JJ]25,25,26
26 READ 126, WIND,J
126 FORMAT [F10.2,I10]
JJ=JJ+J
PRINT 125,I, JJ, WIND
125 FORMAT [15H LEVELS, I4,4H TO ,I3,3H - ,F4.1,4H PSF]
WIND=WIND*BS
25 IF [I-1] 27,27,28
27 WL[1]=[PWH+H[1]/2.]*WIND/1000.
GO TO 24

```

```

28 WL[I]=WL[I-1]+[H[I]+H[I-1]]*WIND/2000.
24 CONTINUE
   PRINT 123
123 FORMAT (29H0 CUMMLATIVE HORIZONTAL SHEAR / 33H          AT STORY LEVEL
   1 SHEAR,KIPS)
   DO 29 I=1,NS
29 PRINT 124,I,WL[I]
124 FORMAT (I20,F13.2)
   CALL CHAIN (3)
   END

```

Call Case 1
Go to 1
End

C LOADING CASE - GRAVITY LOADS

```

COMMON            (SAME AS ABOVE)
EQUIVALENCE       (SAME AS ABOVE)
C            INPUT LOAD FACTORS
   READ 106,F1,F2
106 FORMAT (2F10.2)
   LC=1
   X=F1
C            COMPUTE FACTORED MEMBER END MOMENTS
   PRINT 103,LC,F1
103 FORMAT (19H1            LOADING CASE,I2,16H - GRAVITY LOADS/
   KJ=1
   1 24X,14HLOAD FACTOR = ,F4.2///
   27X , 42HA. FACTORED MEMBER END MOMENTS, FT.-KIPS.//
   3 9H AT LEVEL,4X,5HCOL A,6X,9HGIRDER AB,7X,5HCOL B,6X,9HGIRDER BC,7
   4X,5HCOL C,6X,9HGIRDER CD,6X,5HCOL D/
   523X,4HLEFT,4X,5HRIGHT,14X,4HLEFT,4X,5HRIGHT,14X,4HLEFT,4X,5HRIGHT)
   2 LC=LC+1
   DO 39 I=1,NS
   DO 29 K=1,3
   GM(I,K)=0.0
29 SV(I,K)=0.0
C            COMPUTE FACTORED COLUMN THRUSTS
   DO 36 K=1,4
   ICOL(I,K)=1
36 T(I,K)=X *T(I,K)
   J=0
   DO 31 K=4,12,4
   J=J+1
   G(K)=F1*P(I,J)
   G(K-1)=-G(K)
31 GM(I,J)=G(K)
   G(1)=-.5*G(3)
   G(5)=-.5*[G(4)+G(7)]
   G(9)=-.5*[G(8)+G(11)]
   G(13)=-.5*G(12)
   IF (I-1) 32,32,33
32 DO 34 K=2,14,4
34 G(K)=2.*G(K-1)
   IF (LC-5) 30,39,30

```

```

C          DESIGN COLUMNS FOR VERTICAL LOADS
33 CALL COLUMN
   DO 35 K=2,14,4
35 G[K]=G[K-1]
   IF [LC-5] 40,39,40.
C          OUTPUT MEMBER END MOMENTS
40 PRINT 105, [G[K],K=1,13,4]
105 FORMAT [9X,4[F9.1,18X]]
30 PRINT 104, I, [G[K],G[K+1],K=3,11,4], [G[K],K=2,14,4]
104 FORMAT [I9,3[9X,2F9.1]/9X,4[F9.1,18X]]//
39 CONTINUE
   I=NS+1
   CALL COLUMN
   IF [LC-5] 3,4,3
   PRINT 105, [G[K],K=2,14,4]
C          COMPUTE FACTORED GIRDER SHEARS AND OUTPUT
3 PRINT 107
107 FORMAT [1H1,6X,37HB. FACTORED GIRDER END SHEARS, KIPS.//
1 7H LEVEL,9X,6HBAY AB,12X,6HBAY BC,12X,6HBAY CD]
   DO 37 I=1,NS
   DO 38 K=1,3
   V[2*K]=8.*P[I,K]/XL[K]*F1
38 V[2*K-1]=-V[2*K]
37 PRINT 108, I, [V[K],K=1,6]
108 FORMAT [I7,3[F10.1,F8.1]]
C          OUTPUT FACTORED COLUMN THRUSTS
PRINT 112, [I, [T[I,K],K=1,4], I=1,NS]
112 FORMAT [1H1,5X,28H C. FACTORED COLUMN THRUSTS//2X,5HSTORY,5X,5HCO
1L A,5X,5HCOL B,5X,5HCOL C,5X,5HCOL D/[I7,4F10.1]]
4 X=F2/F1
   DO 20 I=1,NS
   DO 20 K=1,4
20 T[I,K]=T[I,K]*X
   CALL CASE2
   X=F1/F2 ← If (LC-4) 1,2,1
   GO TO 2           1 Return
   END              End
C          LOADING CASE - COMBINED LOADS
SUBROUTINE CASE2
COMMON      [SAME AS ABOVE]
EQUIVALENCE [SAME AS ABOVE]
DIMENSION  PY[92],XMP[92],WST[4],SV[25,3],WLM[25]
DIMENSION  WT[2],COLM[4]
44 GO TO [65,65,63,64,63,62,64],LC
65 FORF2=4.0*F2
   DELTA=0.01
   BB=8.0*[SQRTF[F1/F2]-1.0]*F2
   DO 37 I=1,NS
37 WLM[I]=WL[I]*H[I]*F2
62 PRINT 101,LC
101 FORMAT [19H1          LOADING CASE,I2,17H - WIND FROM LEFT]
   KK=0
   GO TO 36

```

```

63 PRINT 100,LC
100 FORMAT (19H1 . LOADING CASE,I2,18H - WIND FROM RIGHT)
   KK=-1
36 PRINT 102, F2
102 FORMAT (24X,14HLOAD FACTOR = ,F4.2///7X,42HA. FACTORED MEMBER END
1 MOMENTS, FT.-KIPS.///9H AT LEVEL,4X,5HCOL A,6X,9HGIRDER AB,7X,
25HCOL B,6X,9HGIRDER BC,7X,5HCOL C,6X,9HGIRDER CD,7X,5HCOL D/23X,
313HLEFT RIGHT,14X,13HLEFT RIGHT,14X,13HLEFT RIGHT)
   DO 8 K=1,4
   WST(K)=0.0
8 ST(K)=0.0
  SUMWT=0.0
  JX=0
  LL=0
  JJ=0
  LC=LC+1
  DO 1 I=1,NS
  IF(I-JJ)2,2,3
C     INPUT MAXIMUM EFFECTIVE LOAD FACTORS FOR GIRDERS
3 READ 103, F1MAX,F2MAX,F3MAX,J
103 FORMAT (3F10.2,I10)
   JJ=JJ+J
2 IF (I-1) 11,11,16
16 WST[1]=WST[1]-SV[I-1,1]
   DO 57 L=2,3
57 WST[L]=WST[L]+SV[I-1,L-1]-SV[I-1,L]
   WST[4]=WST[4]+SV[I-1,3]
11 IF (I-JX) 70,70,71
71 LL=LL+1
   JX=JX+NSPEC[LL]
   FY=SPEC[LL]
C     COMPUTE REDUCED COLUMN MOMENT CAPACITIES
70 DO 17 K=1,4
   NCOL=ICOL[I,K]
   IF (SPEC[LL]-441.0) 72,73,72
73 IF (NCOL-56) 74,74,75
74 FY=50.0
   GO TO 72
75 IF (NCOL-68) 76,76,77
76 FY=46.0
   GO TO 72
77 FY=42.0
72 RPY=(T[I,K]+WST[K])/PY[NCOL]/FY
25 IF (RPY-0.15) 9,9,10
9 COLM[K]=Z[NCOL]*FY
   GO TO 17
10 COLM[K]=1.18*(1.0-MIN1F(RPY,1.0))*Z[NCOL]*FY
17 CONTINUE
C     COMPUTE WEIGHT FUNCTION AND OPTIMIZE
WTMN=1000000.
IF(I-1) 4,4,5
4 GIRREQ=.5*WLM[1]
  DF=-1.0
  GO TO 40
5 GIRREQ=.5*(WLM[I]+WLM[I-1])

```

```

      DF=-WLM[I]/GIRREQ/2.
      IF [GIRREQ-BB*[P[I,1]+P[I,2]+P[I,3]]] 40,41,41
40 F[1]=F2
      GO TO 42
41 DO 14 K=1,3
      IF [H[I]-H[I-1]]12,13,13
13 IF [P[I,K]-P[I-1,K]] 12,14,14
12 F[1]=F1
14 CONTINUE
42 N=1
18 M=4*N+KK
      G[M]=F[N]*P[I,N]
      M=4*N-1-KK
      IF [F[N]-FORF2] 15,19,19
15 G[M]=P[I,N]*[8.0*F2*[SQRTF[F[N]/F2]-1.0]-F[N]]
      GO TO 20
19 G[M]=F[N]*P[I,N]
20 GO TO [21,22,23],N
21 WT1=H[I]*MAX1F[COLM[1],ABSF[DF*G[3]]]+XL[1]*MAX1F[G[KK+4],GM[I,1]]
38 FMIN=F2
      FMAX=F2MAX
35 F[2]=[FMIN+FMAX]/2.0-2.0*DELTA
      DO 23 K=1,2
      F[2]=F[2]+DELTA
      N=2
      GO TO 18
22 B[3]=[GIRREQ-ABSF[G[3]+G[4]+G[7]+G[8]]]/P[I,3]
      IF [B[3]-8.0*F2] 27,28,28
28 F[3]=B[3]/2.0
      GO TO 29
27 F[3]=[1.0+B[3] / [F2*8.0]]**2*F2
29 IF [F[3]-F3MAX] 32,32,34
32 N=3
      GO TO 18
23 WT[K]=WT1+MAX1F[G[KK+8],GM[I,2]]*XL[2]+MAX1F[G[KK+12],GM[I,3]]*
2 XL[3]+H[I]*[MAX1F[ABSF[DF*[G[4]+G[7]]],COLM[2]]+MAX1F[ABSF[DF*[G[
38]+G[11]]],COLM[3]]+MAX1F[ABSF[DF*G[12]],COLM[4]]]
      IF [WT[1]-WT[2]] 33,34,34
33 FMAX=F[2]
      GO TO 26
34 FMIN=F[2]
26 IF [ABSF[FMIN-FMAX]-0.05] 31,31,35
31 IF [WTMN-WT[2]] 45,45,46
46 DO 39 K=1,3
39 E[K]=F[K]
      WTMN=WT[2]
      IF [F[1]+DELTA-F1MAX] 24,24,45
24 F[1]=F[1]+0.1
      GO TO 42
45 DO 43 K=1,3
43 F[K]=E[K]
      SUMWT=SUMWT+WTMN
      CALL MD
      DO 30 K=1,3
30 GM[I,K]=MAX1F[ABSF[G[4*K]],ABSF[G[4*K-1]],GM[I,K]]
      DO 52 K=1,3

```



```

52 SV[I,K]=[G[4*K]+G[4*K-1]]/XL[K]
   IF [I-1] 60,1,60
C   OUTPUT FACTORED MEMBER MOMENTS
60 PRINT 105, [G[K],K=1,13,4]
105 FORMAT [9X,4[F9.1,18X]]
   1 PRINT 106, I, [G[K],G[K+1],K=3,11,4], [G[K],K=2,14,4]
106 FORMAT [I9,3[9X,2F9.1]/ 9X,4[F9.1,18X]]//
   I=NS+1
   DO 61 K=1,13,4
61 G[K]=G[K+1]
   CALL COLUMN
   PRINT 105, [G[K],K=1,13,4]
C   COMPUTE FACTORED GIRDER SHEARS AND OUTPUT
   PRINT 107
107 FORMAT [44H1      B. FACTORED GIRDER END SHEARS, KIPS.//
1 7H LEVEL,9X,6HBAY AB,12X,6HBAY BC,12X,6HBAY CD]
   DO 49 I=1,NS
   DO 48 K=1,3
   V[2*K]=8.0*F2*P[I,K]/XL[K]
   V[2*K-1]=-V[2*K]+SV[I,K]
   V[2*K]=V[2*K]+SV[I,K]
   IF [I-1] 48,48,56
56 SV[I,K]=SV[I-1,K]+SV[I,K]
48 CONTINUE
49 PRINT 108, I, [V[K],K=1,6]
108 FORMAT [I7,3[F10.1,F8.1]]
C   COMPUTE FACTORED COLUMN THRUSTS AND OUTPUT
   PRINT 112
112 FORMAT [34H1      C. FACTORED COLUMN THRUSTS//
1 7H STORY,5X,5HCOL A,5X,5HCOL B,5X,5HCOL C,5X,5HCOL D]
   DO 51 I=1,NS
   ST[1]=T[I,1] -SV[I,1]
   DO 53 K=2,3
53 ST[K]=T[I,K]+SV[I,K-1]-SV[I,K]
   ST[4]=T[I,4]+SV[I,3]
   DO 54 K=1,3
54 SV[I,K]=0.0
51 PRINT 104, I, [ST[K], K=1,4]
104 FORMAT [I7,4F10.1]
   GO TO 44
64 CALL GIRDER
   RETURN
   END PROGRAM

```

C SUBROUTINE TO DESIGN COLUMNS USING MPC

```

SUBROUTINE COLUMN
COMMON            (SAME AS ABOVE)
EQUIVALENCE       (SAME AS ABOVE)
DIMENSION PY(92),XMP(92),WST(3),SV(25,3),WLM(25)
IF [KJ] 1,1,2
C   INPUT COLUMN SECTION DATA
1 READ 100, [ID[J],W[J],Z[J],J=1,83]

```

```

100 FORMAT (4(I3,F5.1,F7.1))
C      INPUT COLUMN DESIGN YIELD POINTS
      READ 102, (SPEC[J], NSPEC[J], J=1,3)
102 FORMAT (3(F10.2,I10))
      DO 10 J=1,83
      PY[J]=W[J] /490.0*144.0
10 XMP[J]=Z[J] /12.0
      2 IF (I-2) 8,8,9
      8 DO 12 K=1,3
12 WST[K]=0.0
      L=0
      JX=0
      9 J=I-1
C      COMPUTE COLUMN THRUSTS
      DO 13 K=1,3
13 WST[K]=WST[K]+SV[J,K]
      ST[1]=T[J,1]-WST[1]
      DO 22 K=2,3
22 ST[K]=T[J,K]+WST[K-1]-WST[K]
      ST[4]=T[J,4]+WST[3]
      IF(J-JX) 19,19,15
15 L=L+1
      JX=JX+NSPEC[L]
      FY=SPEC[L]
C      CHECK AND/OR SELECT COLUMN SIZES
19 DO 23 K=1,4
      NCOL=ICOL[J,K]
      DO 24 N=NCOL,83
      IF (SPEC[L]-441.0) 33,17,33
17 IF (N-56) 31,31,32
31 FY=50.0
      GO TO 33
32 IF (N-68) 34,34,35
34 FY=46.0
      GO TO 33
35 FY=42.0
33 IF (ABS(F[ST[K]])-PY[N]*FY) 7,7,24
      7 PPY=ST[K]/PY[N]/FY
      IF (PPY-.15) 25,25,26
25 XMPC=XMP[N]*FY
      GO TO 27
26 XMPC=1.18*(1.0-PPY)*XMP[N]*FY
27 IF (XMPC-MAX1(F[ABS(F[G[4*K-2]]),ABS(F[G[4*K-3]])]) 24,24,28
24 CONTINUE
C      ERROR MESSAGE IF INSUFFICIENT COLUMN SECTIONS
      PRINT 101
101 FORMAT (23H COLUMNS JOB TERMINATED)
      CALL EXIT
28 ICOL[J,K]=N
23 CONTINUE
11 RETURN
      END

```

C SUBROUTINE TO DISTRIBUTE MOMENTS FOR COMBINED LOADS

```

SUBROUTINE MD
COMMON      (SAME AS ABOVE)
EQUIVALENCE (SAME AS ABOVE)
DIMENSION  PY(92),XMP(92),WST(3),SV(25,3),WLM(25)
DF=1.0+DF
DO 3 K=1,3
M=4*K+KK
G[M]=F[K]*P[I,K]
M=4*K-KK-1
IF (F[K]-4.*F2)5,4,4
4 G[M]=F[K]*P[I,K]
GO TO 3
5 G[M]      =P[I,K]*(8.0*F2*(SQRTF[F[K]/F2]-1.0)-F[K])
3 CONTINUE
G[1]=-DF*G[3]
G[5]=-DF*(G[4]+G[7])
G[9]=-DF*(G[8]+G[11])
G[13]=-DF*G[12]
IF (I-1) 1,1,2
C CHECK AND REDESIGN COLUMNS FOR COMBINED LOADS
2 CALL COLUMN
1 G[2]=-G[1]-G[3]
G[6]=-G[4]-G[5]-G[7]
G[10]=-G[8]-G[9]-G[11]
G[14]=-G[12]-G[13]
IF (KK) 6,7,7
6 DO 8 K=1,14
8 G[K]=-G[K]
7 RETURN
END

```

C SUBROUTINE TO SELECT LOAD SEQUENCE

```

SUBROUTINE GIRDER
COMMON      (SAME AS ABOVE)
EQUIVALENCE (SAME AS ABOVE)
DIMENSION  PY(92),XMP(92),WST(3),SV(25,3),WLM(25)
DIMENSION  TGM(25,3),ITCOL(25,4)
NN=LC/3
GO TO (1,2),NN
1 TEMPWT=SUMWT
DO 4 I=1,NS
DO 5 K=1,3
5 TGM[I,K]=GM[I,K]
DO 4 K=1,4
4 ITCOL[I,K]=ICOL[I,K]
GO TO 21
2 IF (TEMPWT-SUMWT) 6,6,7
6 DO 8 I=1,NS
DO 9 K=1,3
9 GM[I,K]=TGM[I,K]

```

```

      DO 8 K=1,4
      8 ICOL[I,K]=ITCOL[I,K]
C      OUTPUT LOAD SEQUENCE USED FOR FINAL DESIGN
      7 PRINT 101,NN
101  FORMAT (1H0///13HLOAD SEQUENCE,I2)
      CALL CHAIN [2]
      21 RETURN
      END

```

← Insert statement: 2 Print 100,
and all following statements from
next subroutine.
Combine DIMENSION Statements

```

C      SUBROUTINE TO OUTPUT COLUMN SECTIONS AND
C      SELECT AND OUTPUT GIRDER SECTIONS

```

```

      COMMON      (SAME AS ABOVE)
      EQUIVALENCE (SAME AS ABOVE)
      DIMENSION  PY[92],XMP[92],WST[3],SV[25,3],WLM[25]
      DIMENSION  STEEL[3],IDEPTH[225],WEIGHT[225],PM[225]
      2 PRINT 100
100  FORMAT (19H1      MEMBER SIZES///7X,11HA.  COLUMNS//
      1 2X,5HSTORY,8X,5HCOL A,8X,5HCOL B,8X,5HCOL C,8X,5HCOL D)
      DO 3 I=1,83
      3 W[I]=PY[I]*490.0/144.0
      DO 4 I=1,NS
      DO 4 K=1,4
      J=ICOL[I,K]
      ICOL[I,K]=ID[J]
      4 T[I,K]=W[J]
      MM=4
15  JJ=0
      NN=1
      SUM=0.0
      DO 9 K=1,3
      9 STEEL[K]=0.0
      DO 5 L=1,3
      PRINT 101,SPEC[L]
101  FORMAT (16H0SPECIFICATION A,F4.0//)
      JJ=JJ+NSPEC[L]
C      OUTPUT COLUMN OR GIRDER SECTIONS
      DO 6 I=NN,JJ
      PRINT 102, I, [ICOL[I,K],T[I,K],K=1,MM]
102  FORMAT (5X,I2,4[4X,I2,2HWF,F5.1])
C      COMPUTE WEIGHT OF SECTIONS IN FRAME
      DO 6 K=1,MM
      IF [MM-4] 23,22,23
      22 STEEL[L]=STEEL[L]+H[I]*T[I,K]
      GO TO 6
      23 STEEL[L]=STEEL[L]+[XL[K]-1.0]*T[I,K]
      6 CONTINUE
      SUM=SUM+STEEL[L]
      IF [NS-JJ] 5,8,5
      5 NN=JJ+1
      8 PRINT 103, [SPEC[K],STEEL[K],K=1,3],SUM
103  FORMAT (1H0//6HWEIGHT//3[3H  A,F4.0,F10.1/],7X,F10.1,4H LB.)

```

```

      IF [MM-4] 21,20,21
C     INPUT GIRDER SECTION PROPERTIES
20  READ 104, [IDEPTH[I],WEIGHT[I],PM[I],I=1,221]
104  FORMAT [4[I3,F5.1,F7.1]]
C     INPUT GIRDER DESIGN YIELD POINTS
      READ 106, [SPEC[K],NSPEC[K],K=1,3]
106  FORMAT [3[F10.2,I10]]
      JJ=0
      NN=0
      L=1
      PRINT 105
105  FORMAT [1H1,5X,11HB.  GIRDERS//7H  LEVEL,7X,6HBAY AB,7X,6HBAY BC,
1  7X,6HBAY CD]
C     SELECTION OF GIRDER SIZES
      DO 10 I=1,NS
      IF [I-JJ] 11,11,12
12  JJ=JJ+NSPEC[L]
      FY=SPEC[L]
      L=L+1
11  IF [I-NN] 13,13,14
C     INPUT MAXIMUM DEPTH OF GIRDERS
14  READ 107, [ID[K],K=1,3],J
107  FORMAT [4I10]
      NN=NN+J
13  DO 10 K=1,3
      GM[I,K]=GM[I,K]*12.0/FY
      DO 18 M=1,221
      IF [GM[I,K]-PM[M]] 17,17,18
17  IF [ID[K]-IDEPH[M]] 18,19,19
18  CONTINUE
      M=1
19  ICOL[I,K]=IDEPH[M]
10  T[I,K]=WEIGHT[M]
      MM=3
      GO TO 15
21  CALL CHAIN [1] ← Eliminate when combining subroutines
      END

```

Display A (Continued)

Card No.	Data	Format
1	Frame number	I10
2	Number of stories, bent spacing, bay spacings	I10, 4F10.2
3	Parapet Wall Height	F10.2
4F*	Story Height, No. of stories for which this height is applicable	F10.2, I10
5F	Area live loads & area dead loads for each bay, No. of stories applicable	6F10.2, I10
6F	Wt. of exterior walls, wt. of columns plus fireproofing, No. of stories applicable	2F10.2, I10
7F	Wind pressure, No. of stories applicable	F10.2, I10
8	Vertical loads only load factor, combined loads load factor	2F10.2
9F	Column section properties, depth, weight plastic section modulus	4(I3, F5.1, F7.1)
10	Yield point of columns, number of stories applicable	3(F10.2, I10)
11F	Maximum effective load factors for girder design for each bay, No. of stories applicable	3F10.2, I10
12,13,14	Three sets of data exactly as 11F	
15F	Girder section properties, depth, weight plastic section modulus	4(I3, F5.1, F7.1)
16	Yield point of girders, number of stories applicable	3(F10.2, I10)
17F	Maximum girder depth, No. of stories applicable	4I10
18	Frame Number	I10

* F refers to " and following data cards as required "

Display B Data Specification

END

1	2	3	4	5	6	7	8	9	10	11	12	13	14	15	16	17	18	19	20	21	22	23	24	25	26	27	28	29	30	31	32	33	34	35	36	37	38	39	40	41	42	43	44	45	46	47	48	49	50	51	52	53	54	55	56	57	58	59	60	61	62	63	64	65	66	67	68	69	70	71	72	73	74	75	76	77	78	79	80
-11																																																																															
24					18										24										1																																																						
18					18										18										9																																																						
36.0					10																																																																										
0					0.					0.					6					4.4					2.8					7					5.5					4.0					3					5.7					1.9					Girders																			
2.2					2.6					3.4										1																																																											
1.75					2.6					2.6										9																																																											
2.2					2.6					3.4										1																																																											
1.75					2.6					2.6										9																																																											
2.2					2.6					3.4										1																																																											
1.75					2.6					2.6										9																																																											
2.2					2.6					3.4										1																																																											
1.75					2.6					2.6										9																																																											
36.0					9										441.0										1																																																						
0					0.					0.					6					12.0					8.3					4					13.0					6.3					4					13.0					6.1					Columns																			
1.7					1.3																																																																										
29.0					15																																																																										
45.0					350.0										15																																																																
150.0					120.0										80.0										80.0					150.0					120.0					1																																							
80.0					80.0					80.0										80.0					80.0					80.0					8																																												
30.0					60.0					30.0										60.0					30.0					60.0					1																																												
15.0					1																																																																										
11.0					9																																																																										
4.0																																																																															
10					20.0					30.0										24.0					24.0																																																						
11																																																																															

PRELIMINARY PLASTIC DESIGN OF MULTI-STORY-THREE BAY FRAME NO. 11

FRAME GEOMETRY

NUMBER OF STORIES, 10

BENT SPACING, 20.00 FT.

SPAN LENGTHS, BAY AB 30.00 FT.
 BAY BC 24.00 FT.
 BAY CD 24.00 FT.

STORY HEIGHTS, PARAPET WALL 4.00 FT.
 STORIES 1 TO 9 11.00 FT.
 STORIES 10 TO 10 15.00 FT.

WORKING LOADS

A. GIRDER LOADS
 [PER CENT LIVE REDUCTION BY ASA A58.1]

ROOF GIRDER	BAY AB	BAY BC	BAY CD
WORKING LIVE LOAD, LB./SQ.FT.	30.00	30.00	30.00
WORKING DEAD LOAD, LB./SQ.FT.	60.00	60.00	60.00
WORKING LIVE LOAD, K/FT.	0.60	0.60	0.60
PER CENT REDUCTION OF LIVE LOAD	0.	0.	0.
NET WORKING LIVE LOAD, K/FT.	0.60	0.60	0.60
WORKING DEAD LOAD, K/FT.	1.20	1.20	1.20
TOTAL WORKING LOAD, K/FT.	1.80	1.80	1.80

LEVELS 2 TO 9

WORKING LIVE LOAD, LB./SQ.FT.	80.00	80.00	80.00
WORKING DEAD LOAD, LB./SQ.FT.	80.00	80.00	80.00
WORKING LIVE LOAD, K/FT.	1.60	1.60	1.60
PER CENT REDUCTION OF LIVE LOAD	46.19	38.40	38.40
NET WORKING LIVE LOAD, K/FT.	0.86	0.99	0.99
WORKING DEAD LOAD, K/FT.	1.60	1.60	1.60
TOTAL WORKING LOAD, K/FT.	2.46	2.59	2.59

LEVELS 10 TO 10

WORKING LIVE LOAD, LB./SQ.FT.	150.00	80.00	150.00
WORKING DEAD LOAD, LB./SQ.FT.	120.00	80.00	120.00
WORKING LIVE LOAD, K/FT.	3.00	1.60	3.00
PER CENT REDUCTION OF LIVE LOAD	0.	38.40	0.
NET WORKING LIVE LOAD, K/FT.	3.00	0.99	3.00
WORKING DEAD LOAD, K/FT.	2.40	1.60	2.40
TOTAL WORKING LOAD, K/FT.	5.40	2.59	5.40

B. GIRDER MOMENTS AND SHEARS

LEVEL	MOMENTS			SHEARS					
	BAY AB	BAY BC	BAY CD	BAY AB		BAY BC		BAY CD	
1	101.2	64.8	64.8	-27.0	27.0	-21.6	21.6	-21.6	21.6
2	138.4	93.1	93.1	-36.9	36.9	-31.0	31.0	-31.0	31.0
3	138.4	93.1	93.1	-36.9	36.9	-31.0	31.0	-31.0	31.0
4	138.4	93.1	93.1	-36.9	36.9	-31.0	31.0	-31.0	31.0
5	138.4	93.1	93.1	-36.9	36.9	-31.0	31.0	-31.0	31.0
6	138.4	93.1	93.1	-36.9	36.9	-31.0	31.0	-31.0	31.0
7	138.4	93.1	93.1	-36.9	36.9	-31.0	31.0	-31.0	31.0
8	138.4	93.1	93.1	-36.9	36.9	-31.0	31.0	-31.0	31.0
9	138.4	93.1	93.1	-36.9	36.9	-31.0	31.0	-31.0	31.0
10	303.7	93.1	194.4	-81.0	81.0	-31.0	31.0	-64.8	64.8

C. COLUMN THRUSTS

LEVELS	DEAD LOAD EXTERIOR WALLS	ESTIMATED DEAD LOAD OF COLUMN + FIREPROOFING
1 TO 15	45.00 PSF	350.00 LB/FT

GRAVITY LOADS IN COLUMNS OF FRAME BASED
ON TRIBUTARY AREA OF FLOORS
(WORKING LOADS IN KIPS)

STORY	COL A	COL B	COL C	COL D
1	34.4	52.4	47.0	29.0
2	90.4	124.0	113.0	77.5
3	134.9	182.9	163.6	118.6
4	176.5	252.3	225.6	152.3
5	223.8	321.7	287.6	191.6
6	271.2	391.1	349.6	232.2
7	318.5	460.5	411.7	272.8
8	365.9	529.9	473.7	313.5
9	413.2	599.3	535.7	354.1
10	500.4	696.6	620.2	426.8

D. WIND LOADS AND SHEARS

WIND PRESSURE
LEVELS 1 TO 15 - 29.0 PSF

AT STORY LEVEL	CUMMLATIVE HORIZONTAL SHEAR, KIPS
1	5.51
2	11.89
3	18.27
4	24.65
5	31.03
6	37.41
7	43.79
8	50.17
9	56.55
10	64.09

LOADING CASE 1 - GRAVITY LOADS
LOAD FACTOR = 1.70

A. FACTORED MEMBER END MOMENTS, FT.-KIPS.

AT LEVEL	COL A	GIRDER LEFT	AB RIGHT	COL B	GIRDER LEFT	BC RIGHT	COL C	GIRDER LEFT	CD RIGHT	COL D
1	172.1	-172.1	172.1	-62.0	-110.2	110.2	0.	-110.2	110.2	-110.2
2	117.7	-235.3	235.3	-38.5	-158.2	158.2	0.	-158.2	158.2	-79.1
3	117.7	-235.3	235.3	-38.5	-158.2	158.2	0.	-158.2	158.2	-79.1
4	117.7	-235.3	235.3	-38.5	-158.2	158.2	0.	-158.2	158.2	-79.1
5	117.7	-235.3	235.3	-38.5	-158.2	158.2	0.	-158.2	158.2	-79.1
6	117.7	-235.3	235.3	-38.5	-158.2	158.2	0.	-158.2	158.2	-79.1
7	117.7	-235.3	235.3	-38.5	-158.2	158.2	0.	-158.2	158.2	-79.1
8	117.7	-235.3	235.3	-38.5	-158.2	158.2	0.	-158.2	158.2	-79.1
9	117.7	-235.3	235.3	-38.5	-158.2	158.2	0.	-158.2	158.2	-79.1
10	258.2	-516.4	516.4	-179.1	-158.2	158.2	66.1	-330.5	330.5	-165.2
	258.2			-179.1			66.1			-165.2

B. FACTORED GIRDER END SHEARS, KIPS.

LEVEL	BAY AB	BAY BC	BAY CD
1	-45.9 45.9	-36.7 36.7	-36.7 36.7
2	-62.8 62.8	-52.7 52.7	-52.7 52.7
3	-62.8 62.8	-52.7 52.7	-52.7 52.7
4	-62.8 62.8	-52.7 52.7	-52.7 52.7
5	-62.8 62.8	-52.7 52.7	-52.7 52.7
6	-62.8 62.8	-52.7 52.7	-52.7 52.7
7	-62.8 62.8	-52.7 52.7	-52.7 52.7
8	-62.8 62.8	-52.7 52.7	-52.7 52.7
9	-62.8 62.8	-52.7 52.7	-52.7 52.7
10	-137.7 137.7	-52.7 52.7	-110.2 110.2

C. FACTORED COLUMN THRUSTS

STORY	COL A	COL B	COL C	COL D
1	58.6	89.2	80.0	49.4
2	153.7	210.9	192.0	131.8
3	229.3	310.9	278.0	201.6
4	300.0	428.9	383.5	258.9
5	380.5	546.9	488.9	325.7
6	461.0	664.9	594.4	394.7
7	541.5	782.9	699.8	463.8
8	622.0	900.9	805.3	532.9
9	702.5	1018.9	910.7	602.0
10	850.7	1184.2	1054.4	725.6

Display D (Continued)

LOADING CASE 2 - WIND FROM LEFT
LOAD FACTOR = 1.30

A. FACTORED MEMBER END MOMENTS, FT.-KIPS.

AT LEVEL	COL A	GIRDER AB		COL B	GIRDER BC		COL C	GIRDER CD		COL D
		LEFT	RIGHT		LEFT	RIGHT		LEFT	RIGHT	
1	102.0	-102.0	141.7	-65.3	-76.4	86.9	5.5	-92.4	81.6	-81.6
2	31.9	-100.9	207.6	-31.0	-109.8	124.8	-1.8	-119.0	121.7	-38.5
	68.9			-66.9			-3.9			-83.1
3	25.2	-64.0	221.5	-44.0	-109.8	124.8	-14.1	-88.9	132.0	-52.1
	38.8			-67.7			-21.7			-80.0
4	27.2	-64.0	221.5	-65.7	-67.0	139.9	-32.1	-64.4	140.9	-60.0
	36.7			-88.7			-43.4			-80.9
5	12.7	-28.7	235.3	-92.1	-27.3	155.0	-56.9	-73.7	137.5	-60.9
	16.8			-115.9			-45.3			-76.6
6	13.0	-28.7	235.3	-102.8	-8.5	162.6	-61.6	-26.7	155.3	-70.4
	15.7			-124.0			-74.3			-84.9
7	-2.4	5.2	249.2	-119.3	9.8	170.2	-71.9	-14.1	160.3	-73.9
	-2.8			-139.6			-44.2			-86.5
8	-2.4	5.2	249.2	-152.2	77.4	200.4	-84.5	-18.8	158.4	-73.8
	-2.8			-174.4			-67.0			-84.6
9	-2.4	5.2	249.2	-145.9	61.2	192.9	-119.6	61.6	193.0	-90.7
	-2.8			-164.5			-134.3			-102.3
10	-4.5	11.4	546.7	-211.5	-8.5	162.6	-55.5	-21.2	338.2	-132.8
	-6.9			-326.8			-85.8			-205.3
	-6.9			-326.8			-85.8			-205.3

B. FACTORED GIRDER END SHEARS, KIPS.

LEVEL	RAY AB		RAY BC		RAY CD	
1	-33.8	36.4	-27.6	28.5	-28.5	27.6
2	-44.4	51.5	-39.7	41.0	-40.2	40.4
3	-42.7	53.2	-39.7	41.0	-38.5	42.1
4	-42.7	53.2	-37.3	43.4	-37.1	43.5
5	-41.1	54.9	-35.0	45.7	-37.7	43.0
6	-41.1	54.9	-33.9	46.8	-35.0	45.7
7	-39.5	56.5	-32.8	47.8	-34.2	46.4
8	-39.5	56.5	-28.8	51.9	-34.5	46.2
9	-39.5	56.5	-29.7	50.9	-29.7	50.9
10	-86.7	123.9	-33.9	46.8	-71.0	97.4

C. FACTORED COLUMN THRISTS

STORY	COL A	COL B	COL C	COL D
1	43.5	69.1	62.1	37.3
2	112.7	165.1	148.2	100.4
3	165.2	246.2	212.9	155.6
4	214.1	338.7	293.3	202.7
5	268.7	430.4	376.6	256.3
6	323.4	521.1	458.3	314.5
7	376.5	612.4	540.4	373.4
8	429.5	699.5	626.7	432.1
9	482.6	787.6	707.4	495.2
10	577.3	926.2	810.4	603.3

Display D (Continued)

LOADING CASE 3 - WIND FROM RIGHT Analogous to LOADING CASE 2
LOAD FACTOR = 1.30

LOADING CASE 4 - GRAVITY LOADS Same as LOADING CASE 1
Not reprinted

LOADING CASE 5 - WIND FROM RIGHT Analogous to LOADING CASE 2
LOAD FACTOR = 1.30

LOADING CASE 6 - WIND FROM LEFT Analogous to LOADING CASE 2
LOAD FACTOR = 1.30

LOAD SEQUENCE 2 Indicates second load sequence
(vertical--wind right--wind left)
was used for design of members.

MEMBER SIZES

A. COLUMNS

STORY	COL A	COL B	COL C	COL D
SPECIFICATION A 36.				
1	12WF 40.0	8WF 29.0	5WF 16.0	10WF 39.0
2	12WF 40.0	8WF 35.0	8WF 20.0	8WF 35.0
3	14WF 43.0	12WF 40.0	8WF 32.6	10WF 39.0
4	12WF 53.0	14WF 48.0	12WF 40.0	12WF 40.0
5	14WF 61.0	14WF 61.0	14WF 48.0	14WF 40.0
6	14WF 68.0	14WF 74.0	14WF 61.0	12WF 53.0
7	14WF 74.0	14WF 84.0	14WF 74.0	14WF 61.0
8	14WF 84.0	12WF 99.0	14WF 84.0	14WF 68.0
9	14WF111.0	14WF127.0	12WF106.0	14WF 84.0
SPECIFICATION A441.				
10	12WF 99.0	14WF111.0	14WF 84.0	14WF 74.0

WEIGHT

A 36. 23304.6
A441. 5520.0
A 0. 0.
28824.6 LB.

B. GIRDERS

LEVEL	BAY AB	BAY BC	BAY CD
SPECIFICATION A 36.			
1	16WF 36.0	14WF 26.0	14WF 26.0
2	18WF 45.0	16WF 31.0	16WF 31.0
3	18WF 45.0	16WF 31.0	16WF 31.0
4	18WF 45.0	16WF 31.0	16WF 31.0
5	18WF 45.0	16WF 31.0	16WF 31.0
6	18WF 45.0	14WF 34.0	16WF 31.0
7	18WF 45.0	14WF 34.0	16WF 36.0
8	18WF 45.0	14WF 34.0	16WF 40.0
9	18WF 45.0	16WF 40.0	16WF 40.0
10	24WF 76.0	14WF 34.0	21WF 55.0

WEIGHT

A 36. 29282.0
A 0. 0.
A 0. 0.
29282.0 LB.

A P P E N D I X I V
N O M E N C L A T U R E

A	= ratio of girder end moments, area of section
DF	= distribution factor
F_1	= load factor for vertical loads
F_2	= load factor for vertical loads combined with lateral loads
F_{1E}	= effective load factor
F_y	= yield stress
h	= story height
ΣH	= a concentrated load equal to the sum of the external horizontal loads above a story
ΣH_e	= a concentrated load equal to the sum of the external horizontal loads above a story due to earthquake loading
ΣH_w	= a concentrated load equal to the sum of the external horizontal loads above a story due to wind loading
K	= ratio of lateral load moment capacity of a uniformly loaded girder to the working load moment ($wL^2/16$).
L	= span length
M_g	= girder end moment
M_{min}	= minimum girder end moment
M_p	= plastic moment
M_{pc}	= plastic moment modified to include the effect of axial compression

- M_{pm} = minimum plastic moment
- ΣM_c = summation column end moments at a level
- ΣM_g = summation girder end moments on a level
- n = number of stories from top
- P = axial load
- P_y = axial force corresponding to yield stress level, $F_y A$
- V = vertical reaction
- W = distributed load per unit length
- W_t = weight function
- x = location of second plastic hinge of girder subjected to gravity plus sway moments
- Δ = relative lateral deflection of a story

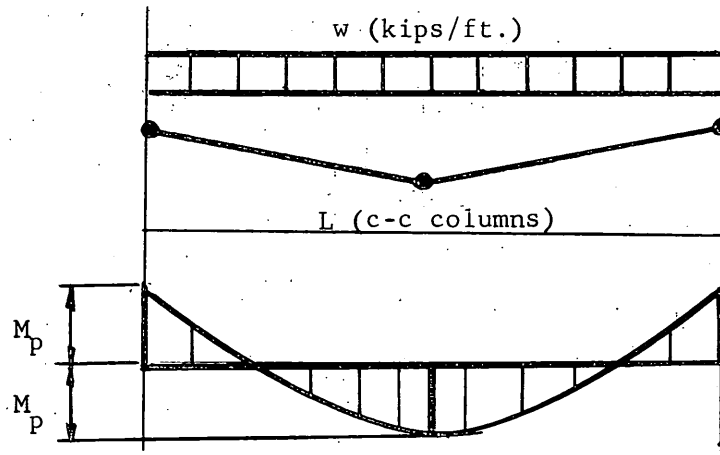

Figure 1 Beam Mechanism

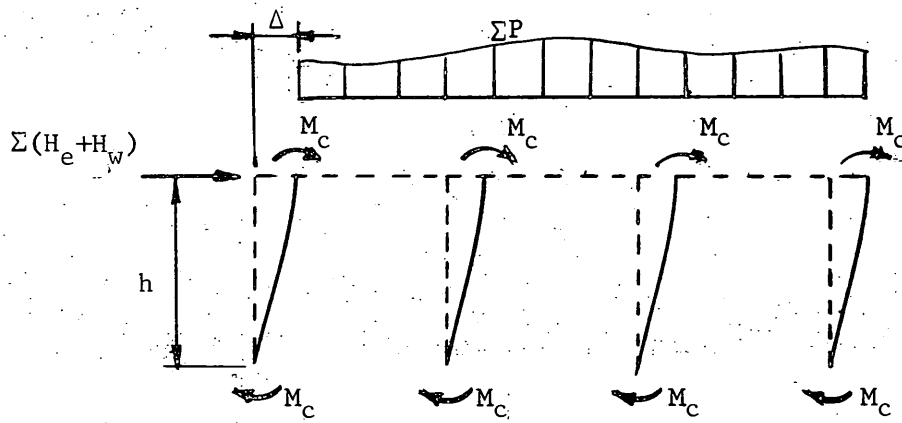

Figure 2 Horizontal Shear Equilibrium in a Story

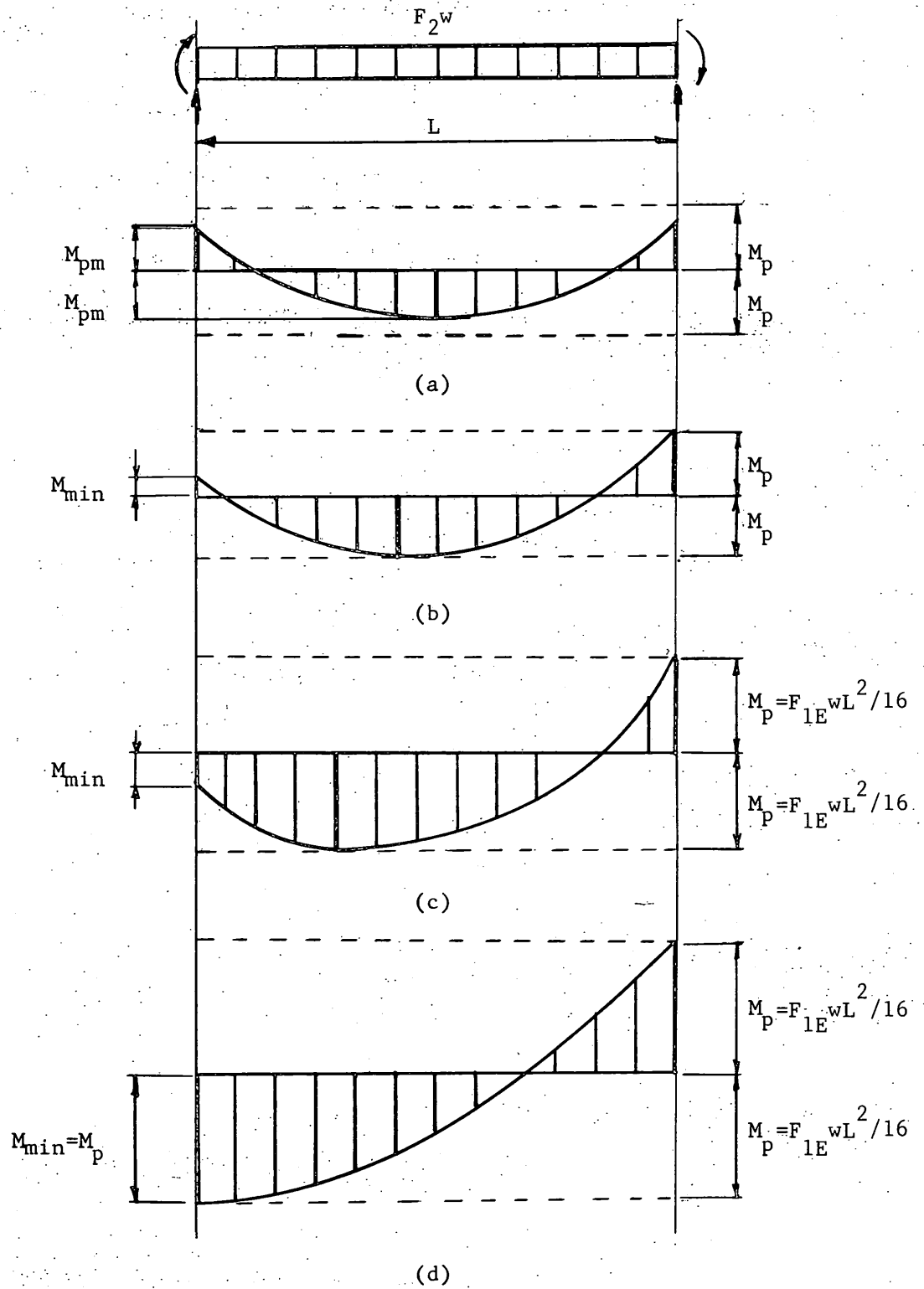

Figure 3 Girders Subjected to Gravity Plus Sway Moments

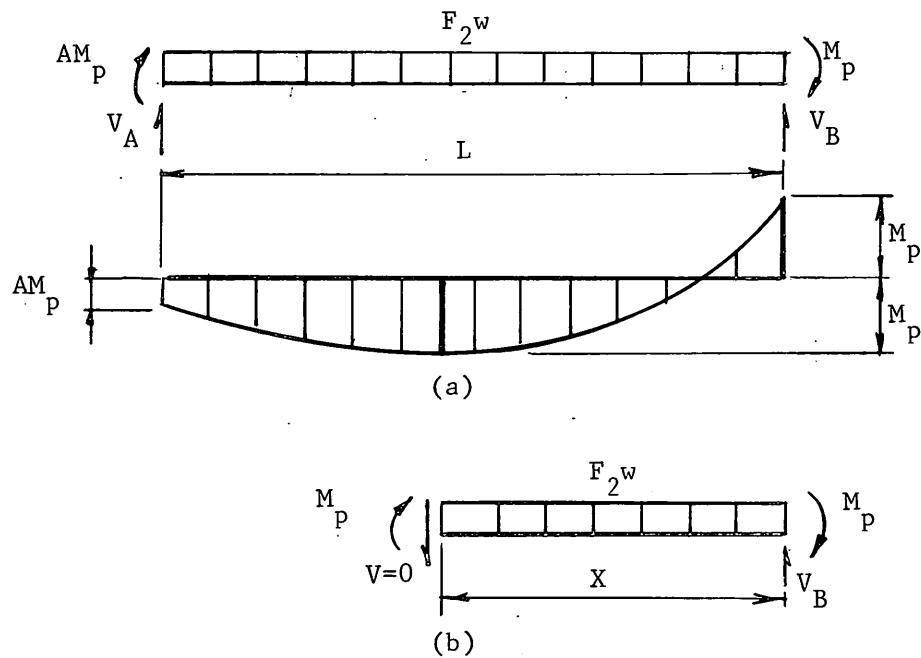

Figure 4 Girders Having Plastic Moments in Clear Span

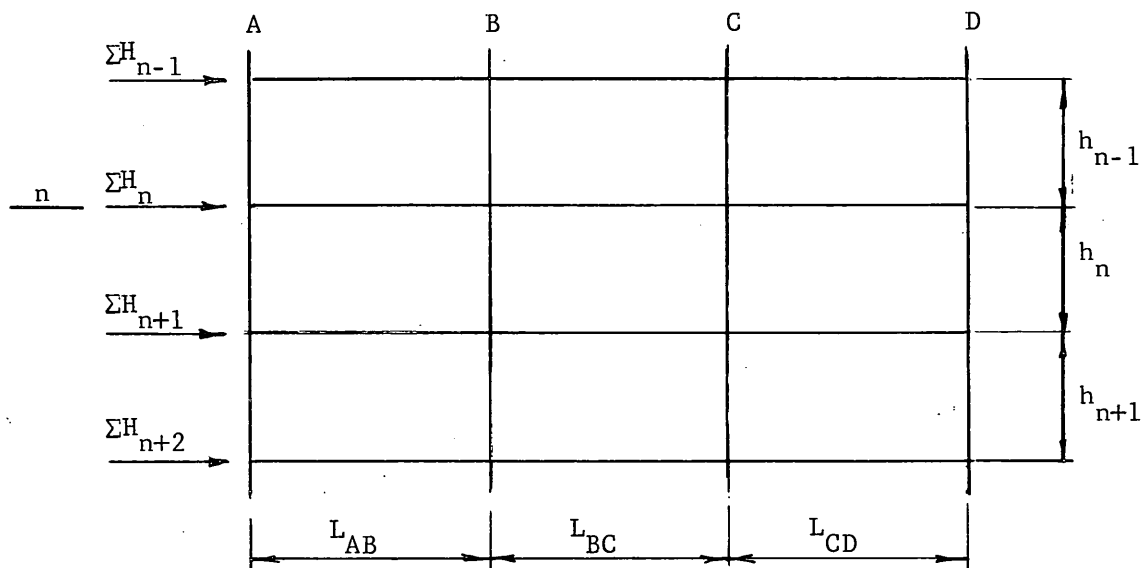

Figure 5 Frame Notation

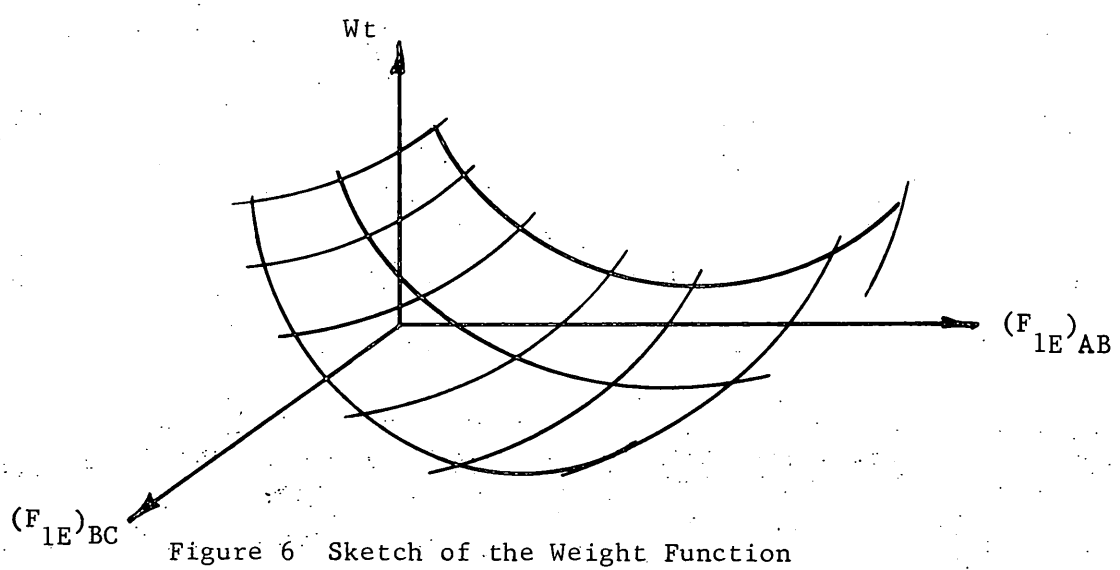

Figure 6 Sketch of the Weight Function

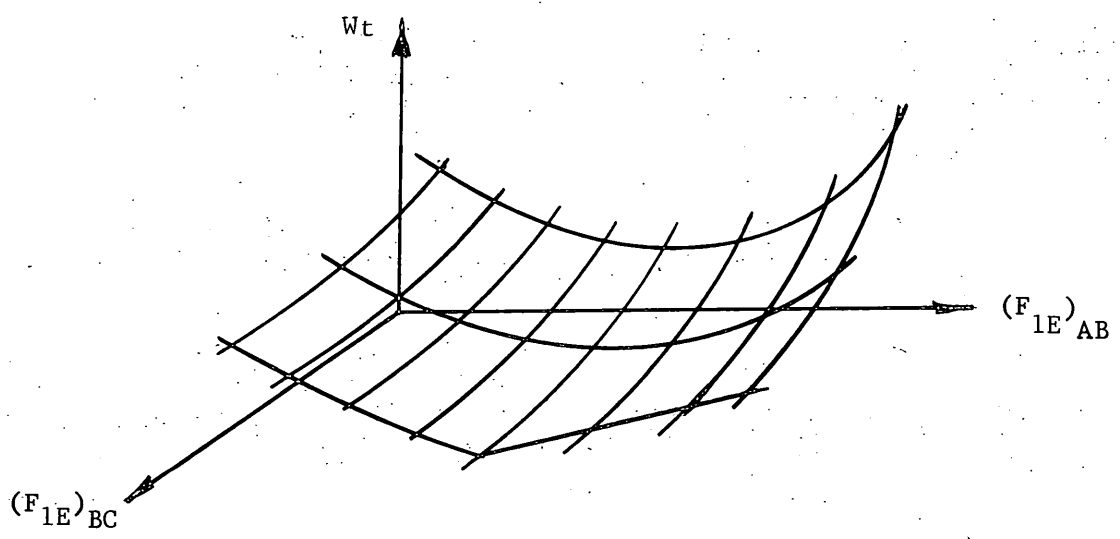

Figure 7 Modified Weight Function

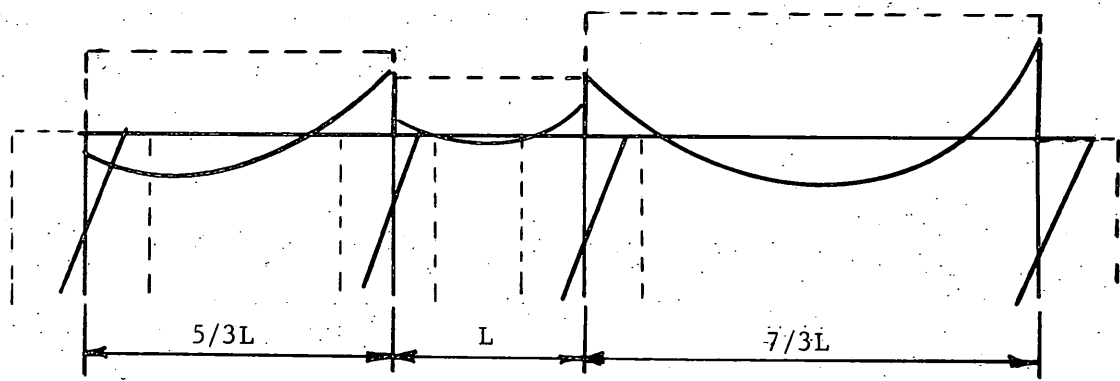

Figure 8 Moment Diagram for Combined Load

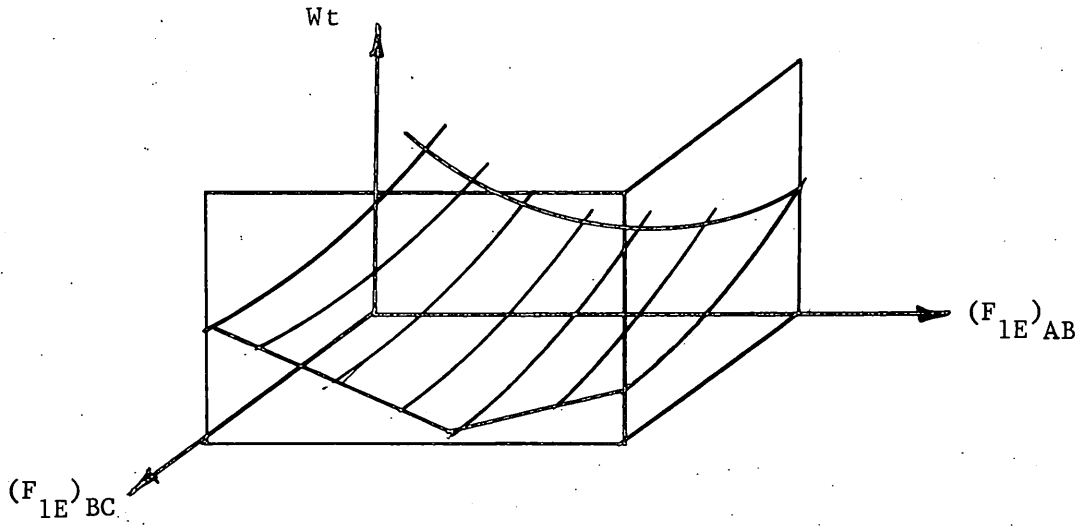

Figure 9 Bounded Weight Function

(+) Slope



(-) Slope

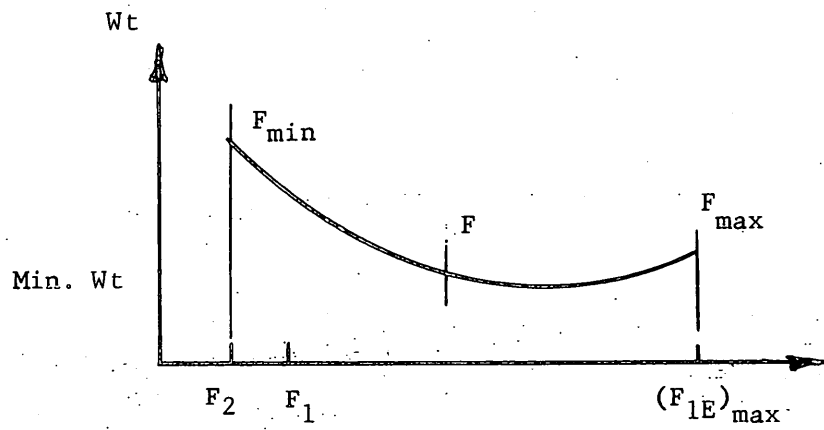

Figure 10 Two-Dimensional Weight Function

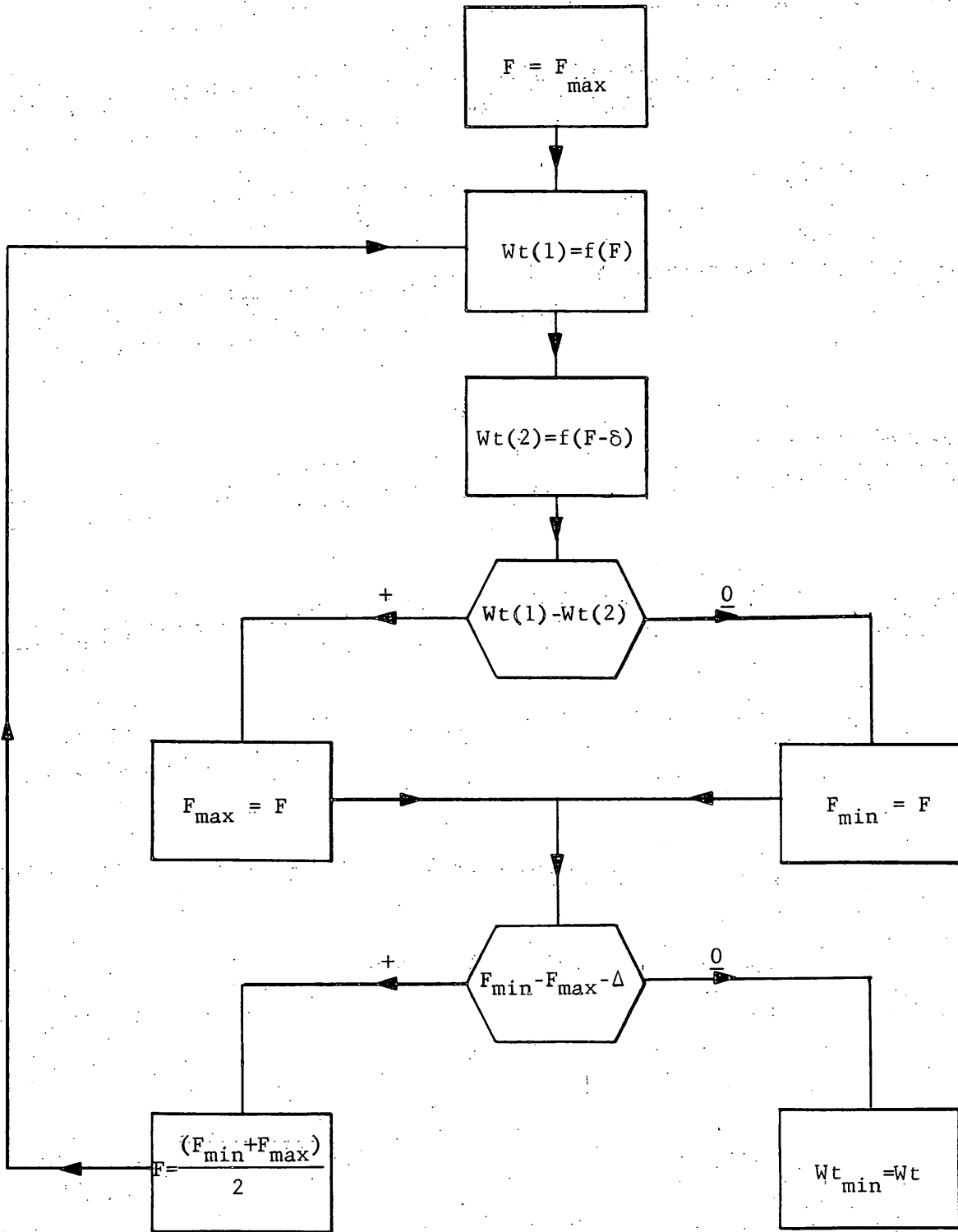

Figure 11 Flow Diagram for Determining Minimum Value of the Weight Function

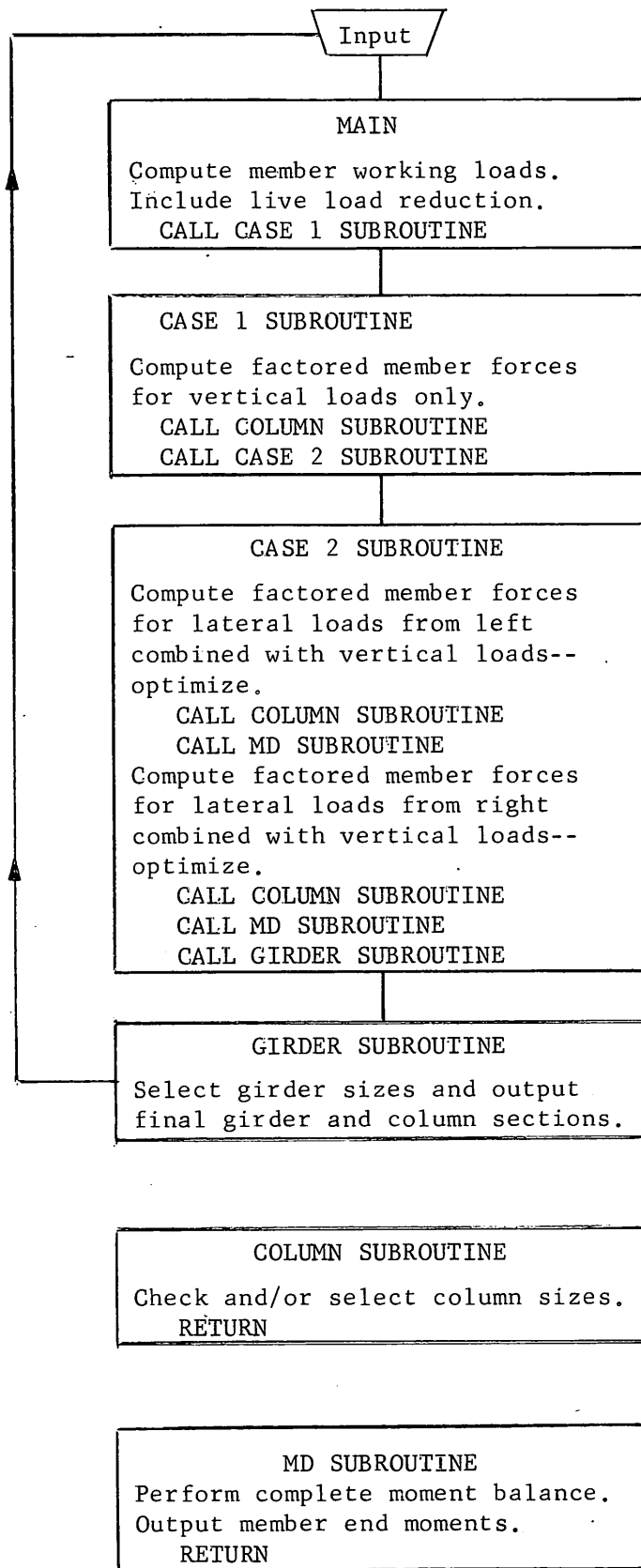
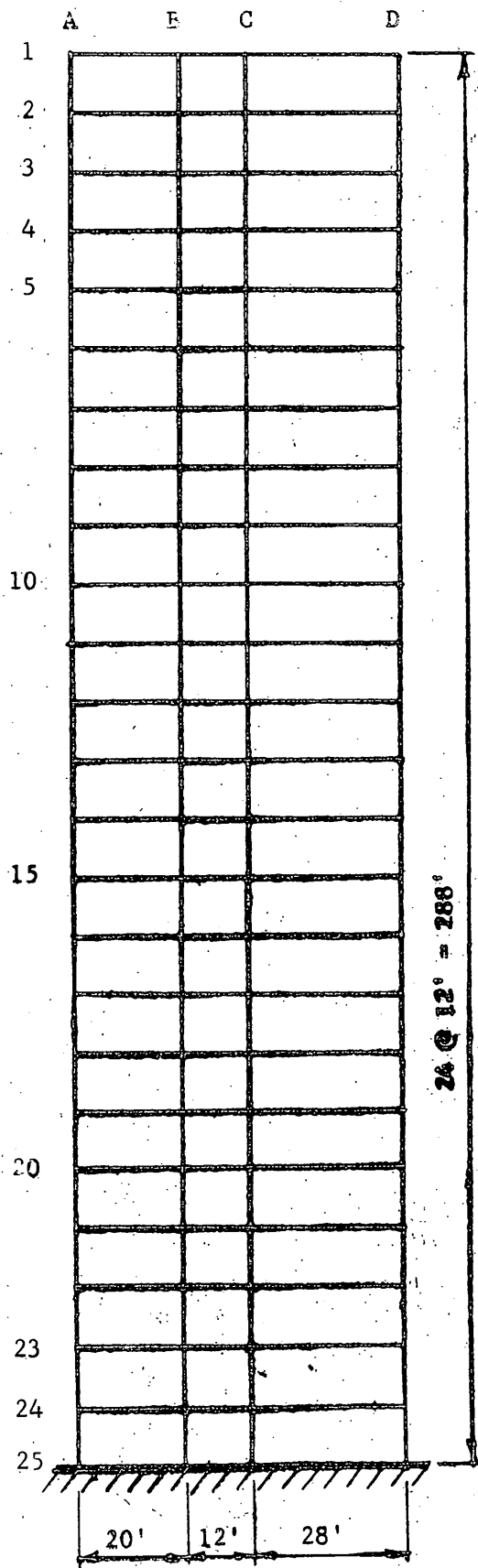

Figure 12 Simplified Flow Diagram



Bent Spacing = 24 ft.

Working Loads:

Roof: $w_L = 30 \text{ psf}$

$w_D = 95 \text{ psf}$

Floors: $w_L = 100 \text{ psf}$

$w_D = 120 \text{ psf}$

Exterior Walls: $w_D = 85 \text{ psf}$

Wind: 20 psf

Column + Fireproofing: 625 lb/ft

Figure 13 Example Frame

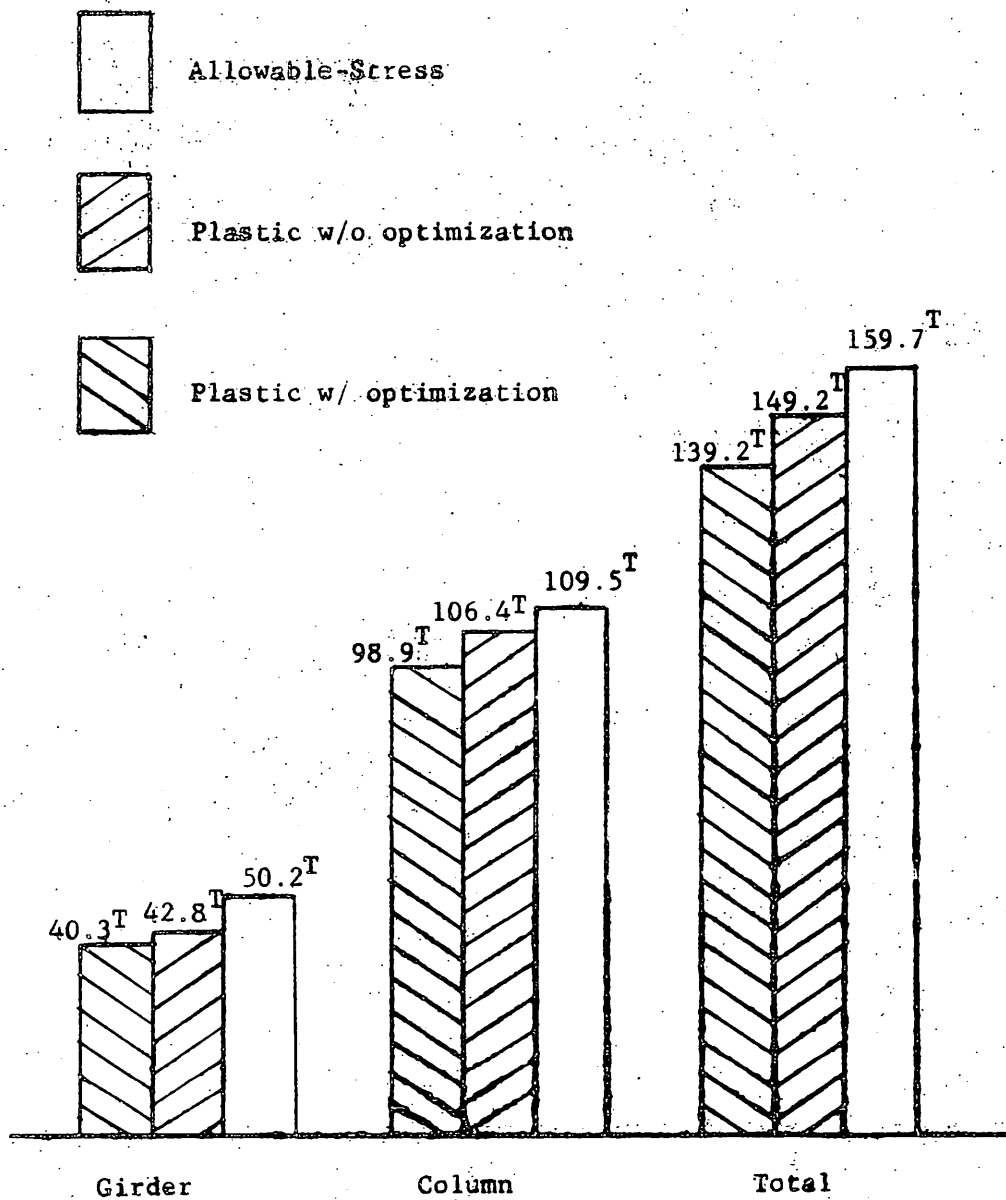

Figure 14 Weight Comparison for Example Frame

R E F E R E N C E S

1. Beedle, Lynn S.
PLASTIC DESIGN OF STEEL FRAMES, John Wiley & Sons,
Inc., New York, N. Y., 1958
2. Neal B. G.
THE PLASTIC METHODS OF STRUCTURAL ANALYSIS, John Wiley
& Sons, Inc., New York, N. Y., 1957
3. Prager, W.
LINEAR PROGRAMMING AND STRUCTURAL DESIGN. I. LIMIT
ANALYSIS, II. LIMIT DESIGN, Papers P-1122, 1123,
Rand Corporation, 1957
4. Driscoll, G. C., Jr.
PLASTIC DESIGN OF MULTI-STORY FRAMES--LECTURE NOTES,
Lecture 6 and 14, Fritz Engineering Laboratory Report
273.20, Lehigh University, 1965
5. American Standards Association
AMERICAN STANDARD BUILDING CODE, (A58.1-1955), ASA,
Washington, D. C.
6. Hansell, W. C.
THE PLASTIC ANALYSIS OF MULTI-STORY FRAMES RESISTING
VERTICAL AND LATERAL LOADS, Fritz Engineering
Laboratory Report No. 273.6, September, 1961
(Unpublished)
7.
STEEL CONSTRUCTION MANUAL, Sixth Edition, American
Institute of Steel Construction, New York, N. Y., 1963
8. Driscoll, G. C., Jr.
MULTI-STORY FRAMES I, Chapter 21, STRUCTURAL STEEL
DESIGN, Ronald Press, New York, 1964
9. Daniels J. H.
PLASTIC DESIGN OF MULTI-STORY FRAMES--LECTURE NOTES,
Lecture 19, Fritz Engineering Laboratory Report.
273.20, Lehigh University, 1965
10. Daniels, J. H. and Lu, Le-Wu
THE SUBASSEMBLAGE METHOD OF DESIGNING UNBRACED MULTI-
STORY FRAMES, Fritz Engineering Laboratory Report No.
273.77, Lehigh University, 1966

11. Hansell, W. C.
PLASTIC MOMENT BALANCING FOR UNBRACED MULTI-STORY
FRAMES Fritz Engineering Laboratory Report 273.41,
Lehigh University, 1966