

Initial Trade Study for In-line Silver Sensor for Spacecraft Potable Water Systems

Phillip Hicks¹

Jacobs Technology, Houston, TX, 77058, U.S.A

and

Jason Nelson² and Michael R. Callahan³

NASA Johnson Space Center, Houston, TX, 77058, U.S.A

Ionic silver is currently baselined as the biocide for microbial control in potable water systems for future space exploration missions. In-line monitoring of silver ion concentration is desired for system feedback control to introduce and maintain sufficient and safe levels of biocide in the water. To date, NASA testing of silver biocide system prototypes has made use of an Ion-Selective Electrode (ISE) for in-line silver concentration measurements. However, known issues with ISE technology have continued to motivate a search for alternate sensor systems. Although devices capable of detecting silver are available for terrestrial applications, these systems are generally not well-suited for the unique demands of spaceflight. Desired attributes include: low weight, volume, and power consumption; stable, autonomous, and in-line measurement capability; long calibration lifetime; and limited maintenance requirements. This paper provides the results from a preliminary trade study conducted on three candidate silver sensor technologies: ISEs, Anodic Stripping Voltammetry (ASV), and Fiber Optic Chemical Sensors (FOCS). The review of these technologies includes the rationale for their selection, an overview of the principles of their operation, and a detailed assessment of their strengths and weaknesses relative to the anticipated requirements of future spacecraft applications. The study concluded that none of the currently-available versions of these technologies is suitable for immediate application to spacecraft systems; further technology development should be considered. To that end, recommendations for forward development work have been proposed and provided herein.

Nomenclature

ASV	=	Anodic Stripping Voltammetry
DLR	=	Dual-lifetime Referencing
DO	=	Dissolved Oxygen
E^0	=	Standard-State Reduction Potential
ΔE_{ISM}	=	Ion-Selective Membrane Potential
FOCS	=	Fiber Optic Chemical Sensors
i_p	=	Peak Current
ICES	=	International Conference on Environmental Systems
IOS	=	Intelligent Optical Systems
ISE	=	Ion-Selective Electrode
ISFET	=	Ion-Sensitive Field Effect Transistor
ISS	=	International Space Station
SBIR	=	Small-Business Innovation Research
SSRE	=	Solid-State Reference Electrode

¹ Project Engineer, Jacobs Technology – JETs Contract, Jacobs Engineering (2224 Bay Area Blvd)

² Water Technology Engineer, Crew and Thermal Systems Division, Mail Stop: EC3 (2101 NASA Pkwy)

³ Water Technology Lead, Crew and Thermal Systems Division, Mail Stop: EC3 (2101 NASA Pkwy)

I. Introduction

NASA intends to replace iodine with ionic silver as the biocide for maintaining the potable quality of water in next-generation spacecraft. Silver is advantageous in that it is safe to drink at levels that are effective at preventing bacterial growth, thus reducing the upmass cost that is currently incurred by iodine removal media. A disadvantage of silver, however, is that its chemistry in aqueous systems is highly dynamic. Studies¹⁻⁴ have demonstrated that significant silver losses on wetted materials in spacecraft water systems can occur within weeks, days, or even hours, depending on the material, its surface treatments, and the effective surface area-to-volume ratio. Although mitigation of this problem is being investigated, it is currently assumed that some degree of silver loss will occur over the long durations of system dormancy (up to a year) envisioned for future missions. An in-line silver sensor would greatly enhance the ability to ensure the quality of the water in such cases by enabling automated maintenance of the silver biocide level. Furthermore, methods for introducing silver into the water are at a low technology readiness level, which results in uncertainty regarding their long-term performance and the consistency of their output. An in-line silver sensor would provide continuous insight into the health of the introduction system and could be used as feedback control depending on the introduction method employed. Thus, in-line silver sensing is currently considered a critical technology gap for a robust silver-based disinfection system.

Although silver monitoring devices are available, they are generally not suited for automated and in-line use. For example, a colorimetric kit for monitoring silver and iodine concentrations was successfully used to periodically assess biocide levels on the International Space Station (ISS).⁵ However, the device is not a candidate for in-line sensing applications because it relies on manual operation and requires samples to be withdrawn from the potable system. For terrestrial applications, most of the methods commonly employed for the detection of silver and other heavy metals are not sensors but rather analytical systems, such as Inductively-Coupled Plasma Mass Spectrometry and Atomic Absorption Spectroscopy. Such systems generally require bulky equipment, some form of sample pretreatment, and experienced operators to run the analysis and interpret the results. Research into the state of the art for silver detection, including correspondence with over forty sensor and analytical device companies, revealed that the only commercially-available device that can truly be considered a sensor for aqueous silver is an Ion-Selective Electrode (ISE). Commercially-available ISEs have several shortcomings that render them unsuitable for the space application, as discussed in detail below. This technology gap motivated a fiscal year 2017 Small Business Innovation Research (SBIR) solicitation⁶ for in-line silver monitoring technologies, which produced some encouraging results, though not yet a viable sensor. Further research and development in sensor technology is required, starting with an assessment of which technologies lend themselves to being adapted to the application and whether it is reasonable to expect that further development could produce a sensor that meets the requirements of future exploration missions.

II. Technology Selection

The selection of technologies to evaluate was conducted by considering all sensor technologies and narrowing the focus to those that are most commonly applied to silver and other heavy metals. This approach ensured the availability of a sufficient body of research to fully evaluate the strengths and weaknesses of each selected technology. Heavy metal sensing technology was included in the consideration because silver shares some characteristics with other heavy metals and because research into general heavy metal detection is more common than research into silver detection specifically. Of the various sensor types, electrochemical and optical are the two most commonly applied to heavy metal detection.

Ion-selective Electrodes (ISEs) are electrochemical sensors that have been developed for nearly every metal ion, including silver, and are commercially-available from a number of companies. The basic principles of ISEs are well understood, and improvements of their shortcomings constitute a large and active area of research.⁷ Ion-sensitive Field Effect Transistors (ISFETs) are also a growing area of research.⁷ Like ISEs, they are potentiometric sensors, and they share enough characteristics with ISEs that they can be treated together in this study with a brief overview of their key differences.

Anodic Stripping Voltammetry (ASV) is a very popular electrochemical technique for trace heavy metal detection. It is an active area of research and has been successfully applied to silver ion detection.⁸⁻¹² Although ASV is an electroanalytical technique as opposed to a sensor technology, systems based on ASV have been developed into small, portable, and robust devices for field use. It is thus conceivable that the sensing capability of ASV could be embodied in a sensor.

Fiber-Optic Chemical Sensors (FOCS), also known simply as optical sensors, are another popular area of research.¹³ They offer convenience as reusable probes and in some cases in-line sensors in remote locations. As reported at last year's International Conference on Environmental Systems (ICES),¹⁴ the company Intelligent Optical

Systems, Inc. (Torrance, CA) designed a luminescence-based optical sensor to address the aforementioned 2017 SBIR solicitation.

Other sensor types for silver detection are also possible. For example, mass-based sensing mechanisms for heavy metal detection have been reported,¹⁵⁻¹⁶ and continued advances in micro-scale technologies could result in additional sensor development in this area. Presently, however, such sensing schemes are less studied and are generally at a lower technology readiness level than the electrochemical and optical variety. Therefore, the three sensing technologies evaluated in this study were Ion-Selective Electrodes, Anodic Stripping Voltammetry, and Fiber-Optic Chemical Sensors.

III. Technology Description

This section provides a description of each technology, in which an overview of the general operating principles is followed by a discussion of the key design elements. This discussion highlights strengths and weaknesses of the technology and provides a necessary background for the subsequent technology evaluation. More thorough explanations of the technologies can be found in the references (ISE¹⁷⁻²⁰; ISFET¹⁷; ASV¹⁹⁻²³; FOCS^{17,24-27}).

A. Ion-Selective Electrode

In an ISE, the concentration of the analyte is determined by measurement of the potential difference (i.e. voltage) across an electrochemical cell consisting of the indicator (i.e. ion-selective) electrode, the reference electrode, and the sample itself. ISEs can be purchased as individual half-cells with a separate reference half-cell or as combination probes with the reference half-cell incorporated. A functional representation of an ISE is depicted in Figure 1.

The potential of interest is that which develops at the ion-selective membrane (shown in purple), which is selectively permeable to the analyte. The potential develops due to the partitioning of charge across the membrane, and is dependent on the activity of the analyte in the sample, a_A , according to the Nernst equation:

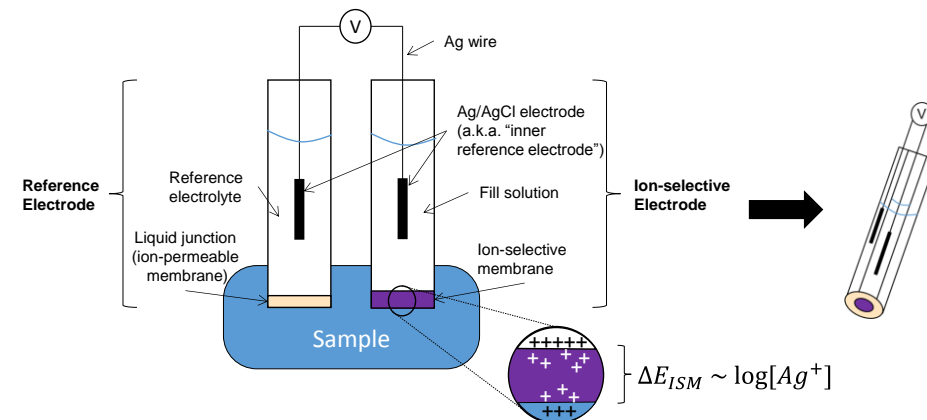

Figure 1. Ion-Selective Electrode. An ISE comprises two electrodes (or "half-cells"): the ion-selective electrode (or "indicator electrode") and the reference electrode. These two half-cells are commonly packaged together into a combination probe.

$$\Delta E_{ISM} = E_{const} + \frac{RT}{zF} \ln a_A = E_{const} + 59.16 \log a_A$$

where ΔE_{ISM} is the ion-selective membrane potential, R is the ideal gas constant, T is temperature in Kelvin, z is the analyte charge (1 for Ag^+), F is Faraday's constant, and E_{const} is a constant to account for the activity of the analyte in the internal fill solution (indicated as "Fill Solution" in Figure 1 and Figure 2) and any mechanical asymmetry of the membrane. As the right-hand equality demonstrates, assuming a temperature of 25°C yields the "Nernstian" slope of 59.16 mV per decade of activity change. Note that the equation is expressed in terms of analyte activity, the chemically-available quantity of the ion, rather than concentration. However, in solutions of very low ionic strength, such as that expected in spacecraft potable water, the activity can be assumed to be equal to the concentration. This assumption is made through the rest of this study.

The ion-selective membrane potential cannot be measured directly, but requires measurement of the voltage across the entire electrochemical cell, which includes contributions from every phase boundary in the cell, as depicted in Figure 2. Thus, obtaining consistently accurate measurements of the ion-selective membrane potential requires keeping the other potentials in the cell constant. The stability of the potential at these other phase boundaries is impacted by the type of contact(s) between the membrane and the inner wire and by the reference electrode. The key design elements of an ISE are thus the ion-selective membrane, the contact type, and the reference electrode.

Membrane type: The two types of ion-selective membrane used for silver detection are solid-state and polymer. A solid-state membrane comprises a crystal of an ion-permeable, sparsely soluble salt such as Ag_2S . Polymer membranes are most commonly implemented as polymer matrices doped with an ionophore (a molecule that selectively promotes the permeation of the analyte). Polymer membranes are popular because they are capable of achieving lower detection limits than solid-state membranes, whose detection limits are thermodynamically limited by the solubility of the sparsely soluble inorganic salt.²⁸ Additionally, solid-state membranes are subject to ‘poisoning’ or ‘fouling’ by organic contaminants, oxide formation at high pH (in excess of about pH 8), and ions that form insoluble complexes with the membrane crystal, such as mercury. Membrane fouling necessitates polishing in order to restore its sensitivity. In spacecraft potable water, organic contaminant levels are low enough that they should not be problematic, mercury is not present, and pH is expected to be roughly neutral. However, the pH is allowed to be as high as 8.5,²⁹ which may occur if the silver ions are introduced via electrolysis. A positive aspect of solid-state membranes is the fact that they may be stored dry, whereas polymer membranes are best stored in a humid environment (e.g., using wetted gauze) and require a period of conditioning in a solution of analyte before use. The response of polymer membranes also tend to be pH-dependent because of the characteristics of the ionophore.

Contact Type: The cell arrangement depicted in Figure 1 and Figure 2 is for a conventional ISE with an inner fill solution and inner Ag/AgCl reference electrode, whose purpose is to provide low resistance charge transfer from the ion-selective membrane to the inner wire and conversion of that charge transfer from ionic to electronic conduction. This configuration is called “symmetric” because the membrane is sandwiched between two solutions. The inner solution can be susceptible to evaporation, pressure and temperature changes, and water transfer to or from the sample.³⁰ To work around these problems, solid contact electrodes have been developed to replace the fill solution with a solid contact between the membrane and the wire in an “asymmetric” configuration. Such a contact must still perform the ionic-to-electronic charge transduction with low resistance or else the contact will be the source of significant potential drift. Because the ionic charge carrier in an Ag_2S solid-state membrane is Ag^+ , which forms a stable redox couple with the Ag wire, an Ag_2S membrane may be directly connected to the wire in what is known as an ohmic contact.²⁸ This is not the case for polymer membranes, however, and suitable contact materials (such as conducting polymers) and novel contact techniques are an active area of research.^{7,30}

Reference Electrode: The reference electrode, which performs the two-fold duty of completing the electrical circuit and maintaining a near-constant reference potential, is a key element in any electrochemical measurement and also a source of several problems. The stable potential it provides is based on the redox couple that makes up the wire coating and the reference electrolyte. The Ag/AgCl electrode in a chloride-containing electrolyte is a very common reference electrode due to the well-behaved nature of its redox couple: $\text{AgCl} + e^- \rightleftharpoons \text{Ag} + \text{Cl}^-$. The reference electrode performs its second function of completing the electrochemical cell’s circuit by allowing its electrolyte to diffuse through the liquid junction, which can be an ion-permeable or porous membrane or simply a narrow opening to the sample. This diffusion of ions can lead to a significant and variable liquid junction potential if the mobilities of the ions that make up the reference electrolyte are dissimilar. Whereas chloride must be contained in the reference

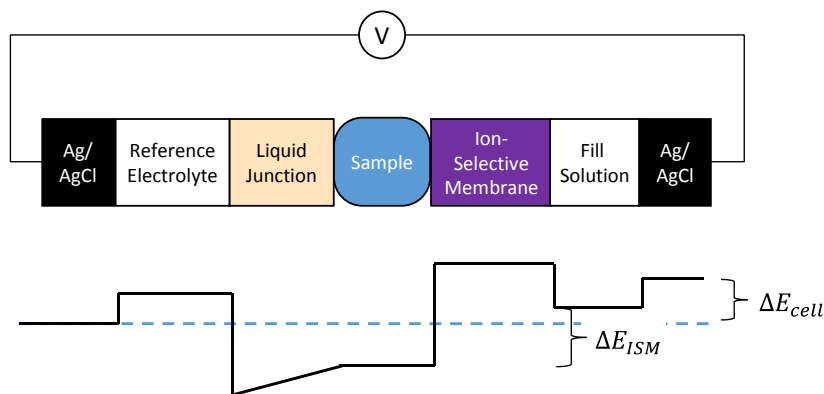

Figure 2. Contributions to ISE Measurement. *The voltage output of an ISE includes potential contributions from every phase boundary in the device. Phase boundaries are depicted in the upper half of the figure with their corresponding contribution to potential directly below.*

electrolyte in order to form a redox couple with the wire coating, the popular choice of potassium as the counter-ion is based on the fact that potassium and chloride ions have very similar ionic mobility, which limits the impact of the liquid junction potential on the overall measurement.

The fact that the migration of this electrolyte is fundamental to the measurement can result in serious problems such as sample contamination and electrolyte depletion. Chloride ions from the electrolyte that migrate into the sample are likely to form an AgCl precipitate with the silver ions. This precipitate is highly insoluble and would reduce the effective silver concentration. Mitigation of this contamination while maintaining the charge transfer function of the electrolyte can be realized by use of a double-junction reference electrode, in which a second electrolyte compartment that does not contain contaminating ions is added between the KCl and the sample. This arrangement can mitigate contamination, but it adds another liquid junction and thus additional measurement uncertainty.

Regardless of whether or not the electrolyte contaminates the sample, there is still the issue of depletion of the electrolyte, which is generally the determining factor in the life of the electrode. The rate of depletion is strongly influenced by the ionic strength of the sample; the purity of spacecraft potable water would lead to accelerated depletion. It is possible to slow the depletion (and contamination) by use of a thicker or less porous reference membrane, but this results in longer response times due to the slower equilibration of the electrochemical cell. Finally, in order to prevent the depletion of the reference electrolyte and drying out of the reference membrane while not in use, it is necessary to store the reference electrode in a solution containing the reference electrolyte, which necessitates care to prevent evaporation of the storage solution.

Other common problems caused by the reference electrode are due to the liquid nature of its electrolyte, such as susceptibility to pressure and temperature changes, flux of solvent across the membrane, and inability to be used in orientations other than upright. Reference electrodes with gel-solidified electrolyte have been developed to address these concerns and are commercially available. One drawback of this type of electrode is the tendency of their reference potential stability to be more influenced by electrolyte diffusion.³¹

Solid-state reference electrodes (SSRE) are an attempt to resolve several of the aforementioned complications. Similar to the solid-contact type of ion-selective half-cell, an SSRE replaces the liquid electrolyte with an ion-to-electron transducing element such as a conducting polymer.³⁰ To enact charge transfer at the electrode-solution interface, the SSRE still must release ions (typically doped into the membrane) into the sample, but this method at least offers a choice of leaked ions and may offer the opportunity for greater control of their release.

At least a few companies offer Ag/AgCl electrodes that are marketed as “leak-free” in that they do not release any ions into the sample. Their charge transfer mechanism is not clear, and it is thus expected that they would not exhibit long-term potential stability. However, the claim is worthy of investigation.

Ion-Sensitive Field Effect Transistor (ISFET): ISFETs are devices that combine the principles of potentiometry with solid-state physics. By coupling an ion-selective layer onto the gate of a field-effect transistor, the analyte concentration influences the FET’s ability to pass current. Holding this current constant results in a voltage between the ISFET and a reference electrode that varies with analyte concentration in a Nernstian fashion. All pH/ion meters contain a FET as part of their signal amplification, and the ISFET’s direct coupling of the ion-selective membrane with the meter electronics confers unique advantages such as sensor miniaturization and elimination of the low-resistance charge-transfer requirement listed above for solid-contact membranes. Nevertheless, an ISFET still requires a reference electrode, which is by far the largest drawback to potentiometric measurement. Thus, in this study, ISFET technology is not evaluated independently.

B. Anodic Stripping Voltammetry

Voltammetry is an electrochemical method in which the current is measured at varied potential in order to characterize the oxidation and reduction (redox) reactions taking place in the electrochemical cell. The cell itself consists of three electrodes, as shown in Figure 3: working (or indicator), counter (or auxiliary), and reference. The working electrode is where the redox reaction takes place, the counter electrode completes the electrical circuit, and the reference electrode provides a stable potential against which to measure the potential of the working electrode. The three-electrode configuration enables separation of the two functions that would otherwise be carried out by the reference electrode, which reduces the demands placed upon it. Control of the electrochemical cell's potential and measurement of its current is done with a potentiostat, which is represented in Figure 3. As shown, the controlled potential is measured between the working and reference electrodes, and the resultant current between the working and counter electrodes. The actual circuitry of a potentiostat is much more complicated, and enables very sensitive current measurement and control of potential in sophisticated profiles.

Anodic stripping voltammetry is a class of voltammetry that allows for very low detection limits by inclusion of an accumulation step. During this step, the analyte is reduced onto the working electrode by maintaining the potential sufficiently below the analyte's standard state reduction potential, E^0 (Figure 4a). The potential is then gradually increased, and as the potential passes through E^0 , ions of the analyte begin to oxidize, or 'strip', from the working electrode, resulting in a sharp increase in current (Figure 4b). The resultant plot of current versus potential is called a voltammogram, the shape of which provides information about the redox reaction(s) at play.

The peak current, i_p , during this potential sweep is related to analyte concentration, c_A , by

$$i_p = K \times c_A$$

where K is a constant based on experimental parameters such as deposition time, working electrode surface area, ionic diffusion properties of the sample, and flowrate (or stirring rate). Because the standard state reduction potential, E^0 , is characteristic of the redox reaction of interest, there is a certain amount of inherent selectivity in ASV. The characteristic nature of E^0 also makes it possible to detect multiple analytes simultaneously, which makes ASV very popular for trace heavy metal detection in environmental waters. Key elements of the design of an ASV analysis include the potential profile, the working electrode, and the reference electrode.

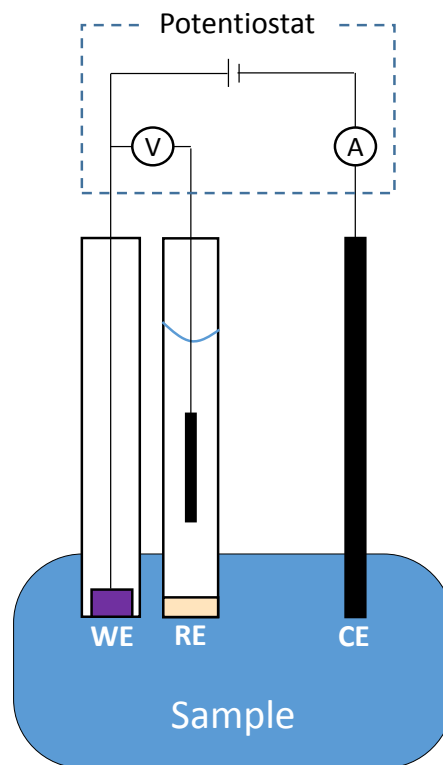

Figure 3. Three-electrode cell. *The potential of the Working Electrode (WE) is determined by measuring the voltage between it and the Reference Electrode (RE). Current flows between the Working Electrode and the Counter Electrode (CE).*

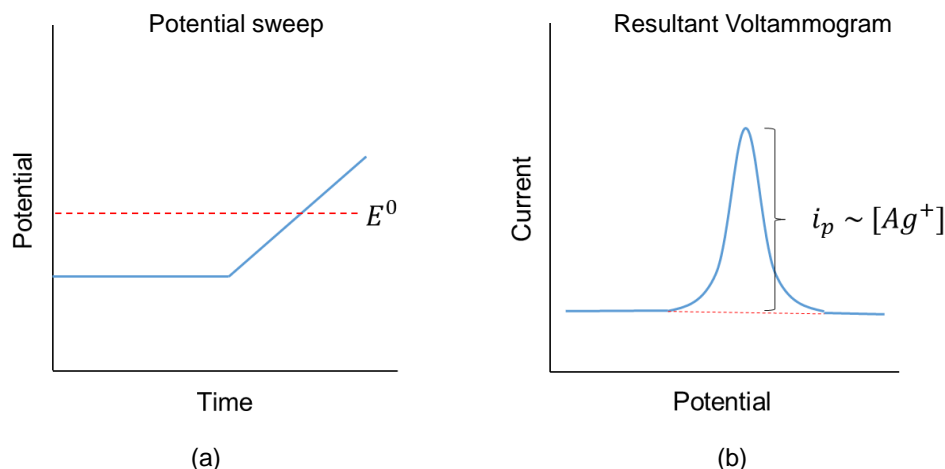

Figure 4. Anodic Stripping Voltammetry. (a) The potential of the working electrode is held below E^0 for the time required to deposit the analyte. It is then swept through E^0 to effect the stripping of analyte from the electrode. (b) The stripping of analyte from the working electrode registers as a peak in current that is proportional to analyte concentration.

Potential Profile: The current that results from redox reactions at the working electrode is related to analyte concentration; however, this “faradaic current” is not the only current present in an electrochemical cell. A change in applied voltage also results in redistribution of charged particles in solution, with cations migrating to the cathode and anions migrating to the anode. This migration results in a transient capacitive current known as charging current. Because the charging current is transient, changing the potential in discrete steps and measuring the current near the end of each step reduces the error that the charging current would otherwise cause. For this reason, the simple linear sweep depicted in Figure 4a is often replaced with a more sophisticated one, such as differential pulse voltammetry, staircase voltammetry, or square wave voltammetry. Another aspect of the potential profile that must be considered is the deposition potential, which is selected to ensure sufficient reduction of the analyte onto the working electrode while also avoiding interference from other sample constituents or impurities.

Working Electrode: The composition of the working electrode must promote electroplating of the analyte and provide an appropriate potential window. The potential window of the electrode is the range of potentials over which the electrode surface itself will not undergo redox reaction, and it must include the range of potentials necessary for the investigation of the analyte. Working electrode materials that have been successfully applied to the determination of silver include graphite felt,¹² carbon paste,¹⁰ glassy carbon,¹¹ and boron-doped diamond.³² Most electrode materials are subject to fouling from organic contaminants and accumulation of electroactive solution impurities. The susceptibility of the working electrode to fouling is highly dependent on several factors, including the working electrode material and any chemical surface modifications, the quality of the sampled water, and the employed potential profile. Regardless, polishing of the working electrode between analyses is generally required, and some companies even offer screen-printed disposable electrodes to avoid the tedium of polishing altogether. For continuous measurements, automated electrode cleaning is required as an alternative to mechanical polishing. Ultrasonic cleaning is possible,³³ though it may be incompatible with certain electrode surfaces, particularly chemically modified ones. Electrochemical cleaning, in which the working electrode is held at a sufficiently high potential to strip away contaminants, is also used. In either case, it is unclear whether such cleaning steps would allow for long-term measurement without frequent recalibration. An electrode material that is not only suitable for silver analysis but also immune to fouling is desired. Boron-doped diamond has been hailed as a relatively fouling-resistant material,³⁴ but it is unclear whether it would permit long-term continuous measurement.

Reference Electrode: In voltammetry, because the potential is not the measured quantity related to analyte concentration, some inaccuracy or instability of the reference potential may be acceptable depending on the conditions of the analysis and its duration. For this reason, pseudo- or quasi-reference electrodes that do not comprise a redox couple are occasionally used in order to prevent sample contamination from reference electrolyte. Bare metal wire or AgCl-coated silver wire immersed directly in the sample fulfill this purpose. However, such reference electrodes are highly pH and temperature dependent and susceptible to long-term drift,³⁵ and it seems very unlikely that their use in

a long-term continuous measurement system would be feasible. Therefore, a true reference electrode is very likely required, and the problems one presents for an ISE are also applicable to voltammetric systems.

Other considerations: Because ASV is an analytical technique not traditionally embodied in an in-line continuous measurement system, additional complications must be considered.

Flowrate: The degree of deposition of the analyte, and thus the resulting current peak during stripping, is highly dependent on its mass transport to the working electrode during deposition. In ASV experiments, stirring is very carefully controlled to ensure deposition consistency. In a flowing system, variations in flowrate have to be precisely accounted for, and operation is likely not possible in completely stagnant conditions.

Dissolved Oxygen: Because dissolved oxygen (DO) readily participates in redox reactions, its removal from solution is generally required in voltammetric measurements to prevent interference with the desired current signal. This is typically accomplished by purging the sample with an inert gas, such as nitrogen. As an alternative, electrode materials that are insensitive to DO are highly sought and studied. Additionally, it has been shown that the very fast potential ramping of square-wave analysis mitigates the impact of DO on mercury electrodes,³⁶ though the success of this technique was at least partially predicated on the properties of mercury. Finally, careful choice of deposition potential may minimize DO's impact. This is especially true for silver analysis, in which the higher E^0 of silver permits higher deposition potential. Nevertheless, recent research in silver detection via ASV has included a deoxygenation step.⁸⁻¹¹

Supporting electrolyte: Voltammetric studies almost invariably include high quantities of inert supporting electrolyte in order to reduce ohmic drop between working and reference electrodes that could otherwise confuse the potential measurement. Studies indicate that ASV is possible without supporting electrolyte by careful design of device and experiment,³⁷ but real-time changes in the conductivity of the water processor effluent might present a challenge.

Analysis: Voltammetry does not provide a single electrical signal that can be converted to a concentration, and its interpretation is generally performed by trained electrochemists. Automated interpretation of the voltammogram would require sophisticated analytical algorithms.

This is not to say that in-line application of ASV is not possible. In fact, it has been performed in various configurations for many years.³⁸ However, these applications generally automate rather than eliminate troubling aspects of ASV, in ways that are impractical on a spacecraft. For example: dissolved oxygen is removed by in-line purging; reagents such as supporting electrolyte and calibration standards are added by precise pumping mechanisms; and analyzed samples are directed to a waste container.

C. Fiber-Optic Chemical Sensor

Fiber-Optic Chemical Sensors (FOCS) employ the basic principles of a spectroscopic measurement in a miniaturized device that allows for in-line sensing. Because most heavy metal ions, including silver ions, do not have optical properties that lend themselves to direct detection, their spectroscopic measurement usually involves high-energy processes or addition of reagents. Optical sensors for ions can forgo these steps by incorporating an analyte-sensitive indicator dye into a sensing membrane and using the optical response of the membrane to determine analyte concentration. The optical response of the membrane is based on either its absorbance or luminescence characteristics, depending on the type of indicator employed. The additional measurement parameters of a luminescence-based sensor, such as emission wavelength and lifetime, confer advantages over absorbance-based sensors such as increased sensitivity and selectivity, and greater flexibility in measurement techniques.²⁶ At the same time, the shortcomings of luminescence-based sensors are generally shared by absorbance-based sensors. Thus, the ensuing assessment of optical sensors focuses primarily on the luminescent variety.*

Two sensing mechanisms commonly applied to heavy metals are ion-exchange and ion-complexation. In ion-exchange, a hydrophobic sensing membrane contains an analyte-specific ionophore and a separate indicator whose spectroscopic properties are mediated by proton binding. Upon permeation of the analyte into the membrane, electroneutrality of the membrane is maintained by the release of a proton, which alters the absorbance or luminescence of the indicator. Because of its dependence on the concentration of protons in the membrane, sensors based on this scheme are highly sensitive to pH, which must either be controlled or compensated for. In the ion-complexation scheme, the absorbance or luminescence of the indicator is directly mediated by bonding with the analyte itself. Because indicators for metals are typically also influenced by protons, sensors based on this scheme

* The term luminescence technically refers to both fluorescence and phosphorescence, which are distinguished by their lifetime. Fluorescence is more common in optical sensors, such that the terms luminescence and fluorescence are often used interchangeably.

also tend to be pH-sensitive at most values of sample pH; however, in this case the pH-sensitivity is a result of indicator-specific chemistry rather than the sensing mechanism itself. Most of the reported optical sensors for heavy metals are of the ion-complexation variety, which is used as the baseline for evaluation in this study.

Analyte complexation with the indicator can either enhance or quench (i.e. diminish) the indicator's luminescence. Most heavy metals have a quenching effect, such that the luminescence intensity is related to the analyte concentration by the Stern-Volmer equation:

$$\frac{I_0}{I} - 1 = K_{SV}[Q]$$

where I_0 is the luminescence intensity in the absence of the quencher, I is the fluorescence intensity in the presence of the quenching analyte at concentration $[Q]$, and K_{SV} is the Stern-Volmer constant for the indicator. In this way, the indicator's luminescence serves as the transduction for the analyte concentration into an electrical signal.** A common arrangement for this type of sensor is shown in Figure 5. The photo-emitter produces light of a known intensity, which is guided by a fiber-optic cable to the sensing membrane, which in turn re-emits (fluoresces) the light with an intensity based on the concentration of analyte. The re-emitted light is guided by another fiber-optic cable to the photo-detector, which registers the fluorescence intensity.

Design variants of luminescent quenching sensors are based on the choice of indicator, the membrane construction, and the measurement technique.

Indicator: Many indicators have been tested for heavy metals. Most are sensitive to pH, but the range and the extent of their sensitivity vary. Also, many indicators are not selective to a given analyte, but rather serve as "total heavy metal" sensors. Some indicators do exhibit selective binding to silver,³⁹ and selectivity of the sensing mechanism can also be enhanced by coupling the indicator to an ionophore, resulting in a so-called fluoroionophore.

Perhaps the most important characteristic of the indicator for in-line sensing is the reversibility of its interaction with the analyte. It is typical of optical sensing schemes for heavy metals that the affinity of the indicator for the analyte is so high that the indicator does not release the analyte even when the analyte concentration decreases or the analyte is not present in the sample at all. In many cases the sensing membrane must be washed with a solution containing a chelating agent of greater affinity for the analyte than the indicator, thus regenerating the membrane. Such regenerable (as opposed to reversible) sensing mechanisms are not feasible for in-line sensing; identifying an indicator with a reversible sensing mechanism is indispensable.

Membrane construction: The composition of the sensing membrane is of critical importance: it must allow permeation of the analyte in order to react with the indicator, and it must effectively immobilize the indicator to prevent it from leaching into the solution. Permeation of the analyte is accomplished by selection of a polymer that allows water absorption, and the use of a fluoroionophore may further promote permeation. In fact, membrane materials used in polymer-based ion-selective electrodes (as discussed above) are often suitable for optical sensors.⁴⁰ Because sufficient permeation must occur in order for the sensor to detect changes in analyte concentration, the composition and thickness of the membrane has a large impact on sensor response time, which is typically longer for optical sensors than for the aforementioned electrochemical techniques.

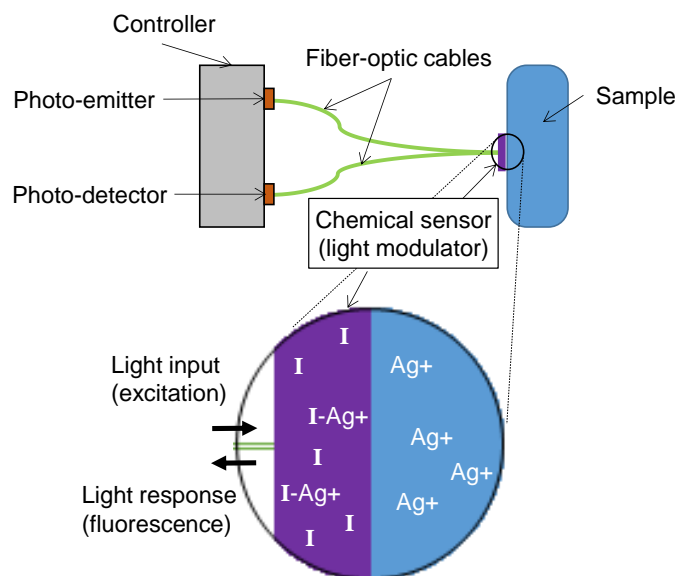

Figure 5. Luminescence-based FOCS. A fiber-optic cable guides excitation light from the photo-emitter to the sensing membrane, which re-emits light as fluorescence. The re-emitted light is guided to the photo-detector by another fiber-optic cable. The degree of fluorescence of the sensing membrane is governed by interactions between the analyte and the indicator (I).

** As is the case with an ISE, an optical sensor is actually measuring analyte activity. However, as discussed above in the section on ISE technology, that distinction is not significant in this application and is not considered here.

Measurement technique: Intensity-based measurements are common due to the simplicity of the hardware and signal analysis required; however, they can be confounded by several complicating factors.²⁷ For example, it is difficult to know the emission intensity at the membrane because of variations in the light source and because not all emitted light makes it to the sensor due to losses in the waveguides. Additionally, drift over time can occur as a result of leaching of the indicator into solution or photobleaching of the sensor. Photobleaching occurs when the excited indicator is involved in irreversible reactions that prevent its fluorescence, manifesting itself as decreased membrane sensitivity in response to light exposure. These complications can negatively impact the accuracy and precision of optical measurements. One method for overcoming these problems is the use of a ratiometric technique in which the intensity is measured at two wavelengths, one of which is uninfluenced by the analyte. This can be accomplished with an indicator that has two absorption or emission wavelengths, or by the inclusion of an inert reference dye with different spectral properties.

An alternative is to relate analyte concentration to fluorescence lifetime in a method known as dual-lifetime referencing,⁴¹ in which an inert luminescent reference dye is incorporated into the membrane along with the indicator. A suitable reference has a similar excitation wavelength but a much longer fluorescence lifetime, such that changes in the fluorescence intensity of the indicator result in a discernable change in the combined indicator/reference lifetime. The fluorescence lifetime can be indirectly determined by use of a phase-resolved measurement, in which the excitation intensity is varied sinusoidally and the resultant fluorescence intensity exhibits a phase-shift. Differences in concentration are thus related to variations in phase angle, as opposed to intensity.

The aforementioned sensor designed by Intelligent Optical Systems (IOS) was a luminescence-based FOCS that employed dual-lifetime referencing with phase-resolved lifetime measurements.¹⁴ This sensor directly addressed several of the requirements for the spacecraft application, and as such is frequently referred to in the evaluation (as the “IOS sensor”).

IV. Evaluation Method

A. Evaluation Criteria

Technologies were evaluated against criteria grouped into three general categories, listed below. For most of the criteria, a qualitative assessment was deemed sufficient. Certain criteria, however, would have been vague without quantification. In an attempt to roughly quantify these criteria, each was assigned an ideal value and a more lenient acceptable value, which were used to determine the performance scores explained in the following section. These values were assigned based on an approximation of the eventual requirements for a silver biocide control system, but given the current absence of actual requirements, the values are, admittedly, somewhat arbitrary and subjective. Furthermore, some of the criteria have overlaps, but they are worth considering separately due to differences in the operation of various devices.

1. Suitability for Spacecraft Application

- a) Size: The combination of mass, volume, and power consumption.
- b) Controller interface: Ability to interface with a controller (i.e., provide electrical signal that may be automatically converted to concentration without human interpretation).
- c) Impact on water: Degree to which the sensor contaminates the water or necessitates its extraction. Sample extraction may be permissible if the sample size were small enough to allow sufficiently-frequent samples while consuming a negligible amount of water.
- d) Environment compatibility: Compatibility with expected environment (e.g., ambient temperature, pressure up to 30 psig, flowrate up to 0.5 L/min) and water quality (pH range 4.5 – 8.5, conductivity < ~4 μ S/cm, dissolved oxygen between ~4-9 ppm)^{††}. Ideally, the sensor would work equally well in flowing and stagnant conditions.
- e) Zero-g compatibility: Ability to operate in zero-gravity.
- f) [Ag⁺] measurement: Ability to measure ionic silver as opposed to total silver, or at least distinguish between them. (A total silver measurement would include complexed silver, which is not biocidal.)

^{††} pH and DO are not currently measured on-orbit in the ISS potable water system. The pH range is based on the allowed pH range for potability, as defined in the System Specification for the ISS.²⁹ The actual pH at the point of silver introduction is expected to be roughly neutral, and may be altered depending on the silver introduction method. The DO range is an estimate based on processes that occur in the ISS water processor.

- g) Continuous measurement: Ability to provide continuous in-line measurement. Note that this requires reversibility of the sensing mechanism, which is defined as the ability for the sensor to naturally return to a baseline value after exposure to higher levels of analyte.

2. Analytical Characteristics

- a) Range: range of measurable concentrations between the limit of detection and the maximum usable indication. Ideal: 10 – 10,000 ppb; Acceptable: 50 – 1,000 ppb. The target silver concentration assumed for this study is 400 ppb, which is a level known to be safe to consume and effective as a biocide. The minimum biocidal concentration and maximum potable concentration have not yet been determined; for this study, an assumption that the concentration must be maintained within at least 400 ± 100 ppb was used to approximate requirements for Range, Accuracy and Precision, and Sensitivity.
- b) Accuracy and Precision: the combined effect of accuracy and precision, the total error, is the value of interest in this study. Ideal: total error less than +/- 5% of total measurement; Acceptable: total error less than +/- 10% of total measurement.
- c) Sensitivity: the change in concentration required to register a discernable signal; defined as the slope of the calibration curve at the concentration of interest. Ideal: 5 ppb; Acceptable: 25 ppb.
- d) Response time / Sample rate: for technologies that provide a continuous electrical signal representative of concentration, response time is evaluated; for technologies that provide discrete samples, sample rate is evaluated. Ideal: < 5 mins; Acceptable: < 15 minutes. As alluded to in the introduction, there are two use cases envisioned for the sensor: (1) health monitoring and feedback control of the silver introduction process, and (2) long-term monitoring of residual silver biocide concentration that may be depleted due to interaction with potable system materials. The ideal and acceptable values listed here are based on the more stringent use case, which is feedback control (a response time of longer than 15 minutes would likely render sensor-based feedback control impractical). It is possible that the silver introduction mechanism will either be sufficiently well-behaved to not require real-time monitoring or will at least lend itself to monitoring via other parameters (such as inlet/outlet conductivity or, for electrolytic introduction, voltage and current). In this case, a response time on the order of a few hours would be acceptable for monitoring residual silver levels.
- e) Selectivity: the extent to which the analytical signal is produced by only the analyte of interest and not interfering substances. The sensor need not be selective against ions that have no realistic source on a spacecraft (e.g., lead or mercury).

3. Reliability and Maintainability

- a) Durability: susceptibility to vibrations, temperature extremes, and/or radiation (specifically electro-magnetic interference) expected in the spacecraft cabin environment, including during the launch-to-activation timeframe.
- b) Maintenance requirements: frequency and duration of any activity requiring crewmember interaction with the hardware, including replacement at end of life. Ideal: 15 minutes or less at a 3-year interval; Acceptable: 30 minutes or less at a 1-year interval.
- c) Calibration interval: timeframe over which sensor output is stable enough to maintain its specified accuracy. Ideal: no calibration required during life of sensor; Acceptable: an automated or remote calibration routine is feasible.
- d) Consumables use: any additional up-mass and volumetric footprint of the system based on consumables such as calibration standards or limited-lifetime components.
- e) Shelf life: ability of spare sensors to be stored on the spacecraft without degrading or losing calibration.

B. Evaluation Scoring System

Since no known sensor technology currently meets the requirements of the application, it would be premature to make a selection from among the technologies by scoring them against one another. Rather, the intent of this trade study is to assess the risk that each technology poses to successful implementation in order to inform future development efforts. Risk was assessed based on a two-dimensional matrix (see Figure 6) that took into account both the current performance of the state-of-the-art of the technology and the prospects for improving any shortcomings of the technology.

Assessing the current performance of a technology in each criterion on a scale from Ideal to Unacceptable serves to weight the criteria. Some criteria are inflexible (such as the ability to function in zero-gravity), while the majority are flexible to some extent, especially in areas in which system requirements are ill-defined. For these flexible criteria, the performance is defined below. Furthermore, definitions of Ideal and Acceptable are provided for certain criteria in the Evaluation Criteria section above.

1. Ideal: expected performance is ideal or satisfies an inflexible criterion.
2. Acceptable: expected performance is acceptable.
3. Probably acceptable: expected performance does not satisfy a criterion, but the criterion could probably be relaxed without significantly increasing requirements for other potable system components.
4. Possibly acceptable: expected performance does not satisfy a criterion, but the criterion could be relaxed by increasing requirements for other potable system components.
5. Unacceptable: expected performance does not satisfy an inflexible criterion.

For criteria in which a technology's performance is not either ideal or acceptable, the prospects for improving that aspect of the technology are assessed. The assessment is based on whether a possible resolution exists for the identified shortcoming and the likelihood of realizing that resolution. For example, the resolution may be only theoretically possible, it may be suggested by the literature but not yet applied, or it may have been tested in a similar application. The assessment is largely subjective, but an effort was made to conform it to the following rubric:

1. Very good: either no problems identified, or problem has resolution that has been tested but not yet applied.
2. Good: problem has a resolution that has been tested or used in a similar application.
3. Moderate: problem has a resolution that has been suggested in literature.
4. Poor: problem has a theoretically possible resolution.
5. Very Poor: problem with no known resolution due to physical limitations of the technology.

Scores for Current Performance and Improvement Prospects are combined to estimate the composite Risk of pursuing the technology based on that criterion. Scores are abbreviated as follows: a letter represents the Risk (U = Untenable, H = High, M = Medium, L = Low, N = None); a number represents the Current Performance score (see Figure 6); and a second number represents the Improvement Prospects score (see Figure 6). For example, if a technology currently exhibits Unacceptable performance in a criterion, and resolutions are theoretically possible but a concrete resolution has not yet been suggested (Improvement Prospects score of Poor), a Risk score of High is assigned and indicated by H-5,4. If the technology's performance in another criterion is deemed Probably Acceptable, and research in the field has identified a potential mitigation that has not yet been tested (Improvement Prospects score of Moderate), a Risk score of Medium is assigned and indicated by M-3,3.

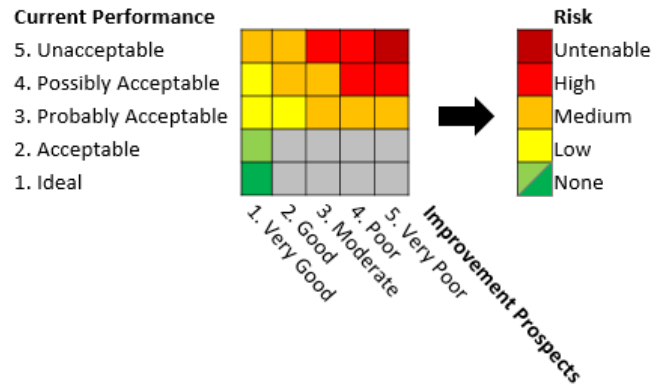

Figure 6. Evaluation Matrix. Current performance of the technology in each criterion is given a score of 1 to 5. For performance scores higher than 2 (not either Ideal or Acceptable), the prospect of improving that performance through additional research and development is given a score of 1 to 5. The combination of Current Performance and Improvement Prospects yields the composite Risk score.

V. Technology Evaluation

Risk evaluation scores for all criteria for each sensor technology are shown in Table 1. Because the majority of the pros and cons of each technology are discussed above, only noteworthy explanations of scores are provided below.

Table 1. Technology Evaluation

		ISE	ASV	FOCS
1. Suitability for Application	Size	N-1,1	N-2,1	N-2,1
	Controller interface	N-1,1	L-3,2	N-2,1
	Impact on water	M-4,3	M-4,3	L-4,1
	Environment compatibility	M-4,3	M-4,3	M-4,2
	Zero-g compatibility	N-1,1	N-1,1	N-1,1
	[Ag ⁺] measurement	N-1,1	N-1,1	N-1,1
	Continuous measurement	N-1,1	H-5,3	H-5,4
2. Analytical Characteristics	Range (min/max)	N-2,1	N-1,1	N-1,1
	Accuracy and Precision	N-2,1	N-2,1	M-4,3
	Sensitivity	N-1,1	N-1,1	M-4,3
	Response time / Sample rate	N-1,1	N-2,1	L-3,2
	Selectivity	N-1,1	N-1,1	N-1,1
3. Reliability and Maintainability	Durability	N-1,1	L-3,1	N-1,1
	Maintenance requirements	M-4,3	H-5,3	N-2,1
	Calibration interval	H-5,4	H-5,4	L-4,1
	Consumables use	H-5,4	H-5,4	N-1,1
	Shelf life	M-4,3	M-4,3	N-1,1

A. Ion-Selective Electrode

Impact on water – The release of KCl reference electrolyte into the potable water stream would result in some extent of biocide reduction due to AgCl precipitation. The use of a double-junction with KNO₃ in the front junction would mitigate this problem, but likely not eliminate it entirely. The problem would be most significant during dormant periods with no silver replenishment. Use of a solid-state reference electrode could further mitigate this concern by replacing the chloride with inert dopant ions.

Environment compatibility – ISEs tend to work best in flowing (or stirred) solutions and give different results in stagnant water. Testing would have to be performed to understand whether an ISE could be relied upon for measuring both flowing and stagnant water. Furthermore, spacecraft potable water quality is such that the silver-sulfide membrane's subjectivity to fouling due to pH is not very likely, but potable water in future spacecraft may reach higher pH values. Due to the pH sensitivity of polymer membrane ISEs, their use as a substitute for a solid-state membrane does not necessarily resolve the problem. Finally, as indicated by the Nernst equation (see above), an ISE's cell potential is impacted by temperature. The temperature dependence is not significant and could possibly be compensated for.

Range (minimum and maximum) – Commercially available ISEs can detect silver over the range of 10 ppb to several thousand ppm. The voltage response is expected to be nonlinear near the limit of detection (less than about 30 ppb), and accuracy and precision are likely to suffer at that lower level. Nevertheless, this performance is acceptable.

Accuracy and Precision – Total error of less than 10% is typical for ISEs.

Sensitivity – Based on a Nernstian slope, a 5 ppb change in the 100-1,000 ppb concentration range is easily detectable by an ISE connected to a standard meter.

Response time – Solid-state ISEs typically provide full response within less than five minutes (often faster).

Selectivity – The only interference with the silver-sulfide ISE response are sulfide and mercury ions, neither of which are expected in the potable water.

Maintenance requirements – If membrane fouling were to occur (see above), polishing of the ISE membrane would be necessary to restore its response. This would require removal of the sensor, and would be unacceptable for all but very infrequent occurrences. Because the likelihood of fouling is not yet clear and is expected to be limited to a pH range that may not be applicable, the current performance is considered possibly acceptable.

Calibration interval – Depending on the ISE, manufacturers recommend calibration at least every week, typically every day or even every use. This frequency is not sustainable in space, but ongoing research into solid contact ISEs and solid-state reference electrodes may reduce the frequency.

Consumables use – The reference electrolyte is considered a consumable because it is gradually used up and determines the overall lifespan of the probe. ISE life is highly dependent on reference electrode construction and water conditions, but in the pure conditions of spacecraft water, lifetime greater than a couple months is unexpected. Use of a solid-contact reference electrode could potentially mitigate (but not eliminate) this concern. Additionally, standards are required for calibration.

Shelf life – Storage requirements for conventional reference electrodes are cumbersome, but could conceivably be implemented. Use of a solid-state reference electrode would avoid any evaporation concerns and would likely result in much longer shelf life. Long-term stability of calibration standards also warrants consideration.

B. Anodic Stripping Voltammetry

Size – ASV requires electronics for interrogation and signal processing in addition to the electrochemical flow cell, but the total package required is small.

Controller interface – The output of ASV (a voltammogram) must be interpreted, typically by an experienced operator. A smart algorithm could conceivably perform the interpretation successfully.

Impact on water – Reference electrode concerns for the ISE are also applicable here.

Environment compatibility – ASV is highly-dependent on flowrate, making its implementation in a system with variable flowrate challenging, at best. Additionally, sensitivity to dissolved oxygen is problematic. Some electrode materials and voltage profiles are less sensitive to dissolved oxygen than others; ostensibly, smart selection of electrode materials and voltage profiles may mitigate this concern. Finally, very low and slightly-variable water conductivity, which are typical in current spacecraft water processor output, also present a challenge for a voltammetric sensor.

Continuous measurement – Fouling of the working electrode is a key concern, given that it necessitates mechanical polishing, some form of cleaning, or replacement to allow for any further measurement to be performed. Current performance is considered unacceptable based on the standard practice of polishing electrodes between measurements. It is possible that certain electrode materials and fabrication techniques can decrease the extent of fouling, and an automated cleaning routine may further mitigate the problem, but commercial use of these techniques is at best uncommon.

Range (minimum and maximum) – Limits of detection for silver using ASV are as low as parts per trillion,^{10,12} but typically parts per billion. The linear range of the response varies, but is expected to cover the range of interest.

Accuracy and Precision – Accuracy of ASV techniques are not typically reported, but electrochemical techniques in general tend to be accurate, such that less than 10% error is a reasonable expectation.

Sensitivity – Low risk: the relationship of peak current to concentration is linear, such that the sensitivity is constant over the measurement range. Slopes for ASV are usually in the range of nA/ppb,^{8,10-11} which of course requires very sensitive current measurement. Commercial potentiostats are capable of detecting current at pA levels, such that this level of measurement is not a concern from a sensitivity perspective.

Sample rate – The voltammetric measurement is a discrete sample because it is the result of interpretation of the voltammogram generated by an entire voltage sweep. The time required for each measurement depends on the voltage scan profile that is employed, whether oxygen is removed, and the duration of the analyte accumulation step. A sample rate of once per 5 – 15 minutes can be expected if the deoxygenation step is excluded.¹²

Selectivity – The oxidation potential of silver is substantially higher than most other metals, including those that might be in the potable system, such that good selectivity is expected.

Durability – ASV measurements are made at very low currents; susceptibility to electromagnetic interference and the necessity for shielding should be investigated if this technology is pursued further.

Maintenance requirements – If automated cleaning routines are unable to fully prevent fouling of the working electrode (see above), polishing would be necessary to restore its response. This would require removal of at least the working electrode, and would be unacceptable for all but very infrequent occurrences.

Calibration interval – ASV research generally does not mention calibration requirements; however, it is reasonable to assume that calibrations would be required on at least a weekly basis due to reference electrode drift and continual modification of the working electrode surface.

Consumables use – Concerns related to the reference electrode and calibration standards for the ISE are also applicable here. Assuming that supporting electrolyte is omitted from measurements and that the working electrode does not require frequent polishing, no other consumables have been identified.

Shelf life – Concerns related to the reference electrode and calibration standards for the ISE are also applicable here. Otherwise, no shelf-life concerns have been identified.

C. Fiber-Optic Chemical Sensor

Size – FOCS require electronics for interrogation and signal processing in addition to the sensing membrane, but the total package is small.

Controller interface – Techniques more advanced than intensity-based measurement (see above) require additional signal processing, but the processing can be accomplished by embedded intelligence.

Impact on water – It is possible for the indicator molecule to leach from the membrane into the water, especially over the very long duration for which the sensor is required. Whether this is problematic depends on whether the indicator is safe to consume in minute quantities. Effective indicator immobilization may prevent its leaching altogether.

Environment compatibility – FOCS are often sensitive to pH; this is highly dependent on the indicator and membrane composition. The IOS report demonstrated that their sensor provides fairly consistent response at pH 4.5 and 9.0, indicating that it is insensitive to pH in that range. However, a different indicator with reversible characteristics may be pH sensitive and accounting for pH may be required. There are no other known complications experienced by FOCS in the relevant environment.

Continuous measurement – Lack of reversibility is a fundamental concern that is common to optical sensors for heavy metals, as discussed above. In the silver and heavy metal sensor research articles that were reviewed for this study, the sensors were either not reversible or reversibility was not reported.^{39,42-49} A couple of these articles reported reversibility when in fact regenerability (with a washing solution) was demonstrated. The IOS sensor was also regenerable but not reversible. A review on optical heavy metal sensors states that although indicator binding is reversible in principle, most complexation reactions with heavy metal ions are not.²⁷ In addition to a number of other performance aspects of an optical sensor, reversibility can be impacted by membrane material and immobilization technique,⁵⁰ such that there is some hope that tweaks to these parameters could promote reversibility. Alternatively, optical sensors based on a principle other than ion-complexation could be investigated. The challenge remains to identify an indicator that is not only reversible, but also selective, relatively insensitive to pH, and able to be immobilized in a membrane effectively.

Range (minimum and maximum) – FOCS for silver generally achieve limits of detection in the ppb range or lower, a couple probes have been reported that sensed silver at less than parts-per-trillion levels.^{43,45} The IOS sensor was effective in the 10-1,000 ppb range.

Accuracy and Precision – Unfortunately, accuracy is rarely reported in optical sensor research, and it is generally the case that optical sensors are less accurate than their electrochemical counterparts. According to Janata in *Principles of Chemical Sensors*, optical sensors are “only semi-quantitative, at best.”¹⁷ Lower accuracy may be acceptable if the minimum and maximum allowed silver concentrations (when determined) are sufficiently far apart.

Sensitivity – Sensitivity of optical sensors is also rarely reported, and concerns similar to those expressed for accuracy and precision are applicable here.

Response time – Response times of optical sensors for heavy metals vary depending on indicator-analyte chemistry and membrane construction, but anywhere from 10-40 minutes seems typical.^{39,44,47-48}

Selectivity – Although many indicators for heavy metals are unselective and are used as total heavy metal sensors, this is not a universal problem. For example, rhodanine has been identified as a suitable and highly selective indicator for silver ions.³⁹ Furthermore, because of their shared “soft metal” classification that gives them similar complexing properties, the primary interfering species in optical sensors for silver are metals like cadmium, mercury, and lead, which are not expected in spacecraft potable water.

Maintenance requirements – The only required maintenance is replacement of a sensor that has reached its end of life. The IOS team demonstrated that this maintenance could be performed on their sensor in less than five minutes.

Calibration interval – A technique such as dual-lifetime referencing (DLR) may enable calibration lifetimes of feasible duration. For example, the IOS team proposed a concept that would avoid in-flight calibration altogether. By using DLR, they claim a calibrated lifetime of at least six months, at the end of which the sensor membrane could

simply be replaced rather than recalibrated (see above). This lifetime is shorter than ultimately desired, but it is longer than any known alternative. Furthermore, because the lifetime is based on exposure to excitation light (rather than other factors such as contact with the process fluid), it should be possible to extend the lifetime by decreasing sampling frequency. Alternatively, a second sensing element could theoretically be placed into the flow cell to take over after the primary sensor reaches its end of life.

Consumables use – With the IOS philosophy, the sensing membranes are treated as consumables. Because they are very small and lightweight (each sensing membrane is a 9 mm diameter disk), several spares could be easily stored on the spacecraft.

Shelf life – The only known storage requirement for an optical sensor is to prevent its exposure to light, which is a simple constraint to meet.

VI. Summary and Outlook

Ion-Selective Electrode technology is attractive based on its simplicity, small size, and analytical characteristics. The major drawback of the technology is the requirement for a reference electrode, which seriously limits the ISE's applicability to long-duration and maintenance-free in-line sensing. Advances in materials science and innovative techniques in reference electrode construction, such as in the solid-state reference electrode, are promising, but the current state of the art of reference electrodes does not adequately address the concerns that they present. Additionally, the solid-state ion-selective membrane type poses moderate risk, and it is not clear that an alternate membrane type would have better performance.

Anodic stripping voltammetry is a powerful analytical technique, offering low detection limits and multi-analyte detection. However, there are several challenges to implementing ASV into a spacecraft sensor in addition to those presented by the reference electrode. These include flowrate and dissolved oxygen sensitivity, working electrode fouling, and complexity of signal interpretation. None of these challenges is insurmountable by itself, but the combination of them makes ASV a less attractive candidate for future research and development.

Optical sensors are attractive for several reasons. For one thing, they do not require a reference electrode, which is a serious disadvantage of electrochemical sensors. Optical sensors also seem to lend themselves well to techniques that enhance their reliability and maintainability, such as pre-calibration of sensors and minimization of maintenance and consumables, as demonstrated by the IOS SBIR efforts. Although analytical characteristics of optical sensors are generally inferior to their electrochemical counterparts, they may be good enough to achieve system requirements if it is determined in the future that those requirements can be relaxed. A key requirement that has not yet been demonstrated by any known optical sensor for silver or other heavy metal ion is continuous measurement capability based on reversibility of the sensing mechanism. If optical sensor reversibility is achieved and demonstrated in the future, the technology would likely be the front-runner for further research and development.

This study only considered methods for directly measuring silver concentration, but it would also be worthwhile to investigate other methods for assessing water quality in real time, such as those that provide an indication of microbial activity or a secondary indication of silver ion concentration. For example, sensitive conductivity sensors at the inlet and outlet of a silver introduction device may provide insight into the resultant concentration, though such a method has its own challenges due to the low conductivity of aqueous silver at the target concentration. Furthermore, non-selective methods such as this have limited utility in determining residual silver levels, which may be the more important use case for an in-line sensor. However, given the challenges associated with in-line silver detection, such schemes should be investigated in parallel with efforts to develop a silver sensor.

VII. Conclusion

In-line measurement of silver ion concentration in a spacecraft application poses many unique challenges, which the current state-of-the-art technology does not fully address. Although certain sensor requirements could be relaxed, the primary shortcomings of each of the evaluated technologies relate to inflexible criteria. While optical sensor technology seems to have the fewest number of obstacles to implementation, no sensor technology strongly recommends itself for near-term implementation. Further research and development, focused on the identified areas of concern, is required for realization of a viable sensor. Meanwhile, efforts to enhance understanding of the silver introduction mechanism and loss rates may help to reduce the demands placed on a silver sensor.

Acknowledgments

The technical consultation and editorial suggestions of Amy Button-Denby, Dean Muirhead, and John Steele were greatly appreciated.

References

- ¹ M. R. Callahan, N. M. Adam, M. S. Roberts, J. L. Garland, J. C. Sager and K. D. Pickering, "Assessment of Silver Based Disinfection Technology for CEV and Future US Spacecraft," in *International Conference on Environmental Systems*, 2007.
- ² W. T. Wallace, S. L. Castro-Wallace, C. M. Kuo, L. J. Loh, E. Hudson, D. B. Gazda and J. F. Lewis, "Effects of Material Choice on Biocide Loss in Orion Water Storage Tanks," in *International Conference on Environmental Systems*, Vienna, 2016.
- ³ W. T. Wallace, S. L. Wallace, L. J. Loh, C. M. Kuo, E. K. Hudson, T. J. Marlar and D. B. Gazda, "Effects of materials surface preparation for use in spacecraft potable water storage tanks," *Acta Astronautica*, no. 141, pp. 30-35, 2017.
- ⁴ M. Petala and e. al, "Silver deposition on stainless steel container surfaces in contact with disinfectant silver aqueous solutions," *Applied Surface Science*, no. 396, pp. 1067-1075, 2017.
- ⁵ D. Gazda, J. Schultz, L. Siperko, M. Porter, R. Lipert, S. Flint and J. McCoy, "In-Flight Water Quality Monitoring on the International Space Station (ISS): Measuring Biocide Concentrations with Colorimetric Solid Phase Extraction (CSPE)," *American Institute of Aeronautics and Astronautics*, 2011.
- ⁶ "SBIR Solicitation 2017 H3.02 Environmental Monitoring for Spacecraft Cabins; In-Line Silver Monitoring Technologies.," [Online]. Available: <https://www.sbir.gov/sbirsearch/detail/1227031>.
- ⁷ E. Zdrachek and E. Bakker, "Potentiometric Sensing," *Analytical Chemistry*, no. 91, pp. 2-26, 2019.
- ⁸ Metrohm, "Determination of silver by anodic stripping voltammetry at the carbon RDE," [Online]. Available: <https://www.metrohm.com/en/applications/AB-207>.
- ⁹ J. Tashkhourian, S. Javadi and F. N. Ana, "Anodic stripping voltammetric determination of silver ion," *Microchim Acta*, no. 173, pp. 79-84, 2011.
- ¹⁰ R. Zhiani, M. Ghanei-Motlag and I. Razavipanah, "Selective voltammetric sensor for nanomolar detection of silver ions using carbon paste electrode modified with novel nanosized Ag(I)-imprinted polymer," *Journal of Molecular Liquids*, no. 219, pp. 554-560, 2016.
- ¹¹ M.-C. Radulescu, A. Chira, M. Radulescu, B. Bucur, M. P. Bucur and G. L. Radu, "Determination of Silver(I) by Differential Pulse Voltammetry Using a Glassy Carbon Electrode Modified with Synthesized N-(2-Aminoethyl)-4,4'-Bipyridine," *Sensors*, no. 10, pp. 11340-11351, 2010.
- ¹² T. Davies, "Anodic stripping voltammetry with graphite felt electrodes for the trace analysis of silver," *Analyst - Royal Society of Chemistry*, no. 141, pp. 4742-4748, 2016.
- ¹³ X.-d. Wang and O. S. Wolfbeis, "Fiber-Optic Chemical Sensors and Biosensors (2013-2015)," *Analytical Chemistry*, no. 88, pp. 203-227, 2016.
- ¹⁴ J. Delgado, R. Sullivan, P. DiCarmine and D. Berry, "Compact Optical Monitor for Silver Ions in Spacecraft Water Systems," in *International Conference on Environmental Systems*, Albuquerque, 2018.
- ¹⁵ A. Rahafrooz and S. Pourkamali, "Resonant MEMS Sensors for Detection of Aqueous Heavy Metal Ions with Sub-ppm Resolution," in *IEEE International Conference on Electron Devices and Solid-state Circuits*, 2008.
- ¹⁶ Z. Ramshani, S. G. R. Avuthu, B. Narakathu and J. Wabeke, "SH-SAW sensor based microfluidic system for the detection of heavy metal compounds in liquid environments," *Sensors and Actuators B: Chemical*, no. 217, 2014.
- ¹⁷ J. Janata, "Principles of Chemical Sensors," Springer, 2009, pp. 99-239, 267-310.
- ¹⁸ E. Lindner and B. D. Pendley, "A tutorial on the application of ion-selective electrode potentiometry: An analytical method with unique qualities, unexplored opportunities and potential pitfalls," *Analytica Chimica Acta*, no. 762, pp. 1-13, 2013.

- ¹⁹ D. Harvey, Chemistry Libre Texts, [Online]. Available: [https://chem.libretexts.org/Textbook_Maps/Analytical_Chemistry_Textbook_Maps/Map%3A_Analytical_Chemistry_2.0_\(Harvey\)](https://chem.libretexts.org/Textbook_Maps/Analytical_Chemistry_Textbook_Maps/Map%3A_Analytical_Chemistry_2.0_(Harvey)).
- ²⁰ E. M. Gross, R. S. Kelly and D. M. Cannon, Chemistry Libre Texts, [Online]. Available: https://chem.libretexts.org/Core/Analytical_Chemistry/Analytical_Sciences_Digital_Library/JASDL/Courseware.
- ²¹ W. Ellis, "Anodic Stripping Voltammetry," *Topics in Chemical Instrumentation*, vol. 50, no. 3, pp. A131-A147, 1973.
- ²² T. Copeland and R. Skogerboe, "Anodic Stripping Voltammetry," *Analytical Chemistry*, vol. 46, no. 14, pp. 1257A-1268A, 1974.
- ²³ J. Barón-Jaimez and e. al, "Anodic stripping voltammetry - ASV for determination of heavy metals," *Journal of Physics: Conference Series*, 2013.
- ²⁴ H. H. Qazi, A. B. b. Mohammad and M. Akram, "Recent Progress in Optical Chemical Sensors," *Sensors*, no. 12, pp. 16522-16556, 2012.
- ²⁵ M. Pospíšilová, G. Kuncová and J. Trogel, "Fiber-Optic Chemical Sensors and Fiber-Optic Bio-Sensors," *Sensors*, no. 15, pp. 25208-25259, 2015.
- ²⁶ I. Oehme and O. Wolfbeis, "Optical Sensors for Determination of Heavy Metal Ions," *Mikrochimica Acta*, no. 126, pp. 177-192, 1997.
- ²⁷ S. Urek, N. Francic, M. Turel and A. Lobnik, "Sensing Heavy Metals Using Mesoporous-Based Optical Chemical Sensors," *Journal of Nanomaterials*, vol. 2013, no. Article ID 501320, p. 13 pages, 2013.
- ²⁸ C. Brett and A. M. Oliveira Brett, *Electrochemistry: Principles, Methods, and Applications*, Oxford: Oxford Science Publications, 1993.
- ²⁹ National Aeronautics and Space Administration, *System Specification for the International Space Station, SSP 41000 Revision CJ*, July 2018.
- ³⁰ J. Hu, A. Stein and P. Buhlmann, "Rational design of all-solid-state ion-selective electrodes and reference electrodes," *Elsevier: Trends in Analytical Chemistry*, no. 76, pp. 102-114, 2016.
- ³¹ K. Maksymiuk, A. Michalska, A. Kisiel and Z. Galus, "Silver Electrodes," in *Handbook of Reference Electrodes*, Berlin, Springer-Verlag, 2013, pp. 92-96.
- ³² A. Saterlay, F. Marken, J. Foord and R. Compton, "Sono-electrochemical investigation of silver analysis at a highly boron-doped diamond electrode," *Talanta*, no. 53, pp. 403-415, 2000.
- ³³ W. T. Dietze, "Method for Ultrasonic Cleaning of a Working Electrode in Electrochemical Cell Useful for Automated Trace Metals Measurement". United States Patent 8,097,148, 17 January 2012.
- ³⁴ S. E. Ward Jones and R. G. Compton, "Stripping Analysis using Boron-Doped Diamond Electrodes," *Current Analytical Chemistry*, no. 4, pp. 170-176, 2008.
- ³⁵ G. Inzelt, "Pseudo-reference electrodes," in *Handbook of Reference Electrodes*, Berlin, Springer-Verlag, 2013, pp. 331-332.
- ³⁶ M. Wojciechowski, W. Go and J. Osteryoung, "Square-Wave Anodic Stripping Analysis in the Presence of Dissolved Oxygen," *Analytical Chemistry*, no. 57, pp. 155-158, 1985.
- ³⁷ M. Cizkowska and Z. Stojek, "Voltammetry in solutions of low ionic strength: Electrochemical and analytical aspects," *Journal of Electroanalytical Chemistry*, no. 466, pp. 129-143, 1999.
- ³⁸ A. Economou, "Recent developments in on-line electrochemical stripping analysis—An overview," *Analytica Chimica Acta*, no. 683, pp. 38-51, 2010.
- ³⁹ S. Rastegarzadeh and V. Rezaei, "A Silver Optical Sensor Based on 5(p-Dimethylaminobenzylidene)rhodanine Immobilized on a Triacetylcellulose Membrane," *Journal of Analytical Chemistry*, vol. 63, no. 9, pp. 897-901, 2008.
- ⁴⁰ R. D. Johnson and L. G. Bachas, "Ionophore-based ion-selective potentiometric and optical sensors," *Analytical Bioanalytical Chemistry*, no. 376, pp. 328-341, 2003.
- ⁴¹ I. Klimant, C. Huber, G. Liebsch, G. Neurater, A. Stangelmayer and O. Wolfbeis, "Dual Lifetime Referencing (DLR) - a New Scheme for Converting Fluorescence Intensity into a Frequency-Domain or Time-Domain Information," in *New Trends in Fluorescence Spectroscopy*, Berlin, Springer-Verlag, 2001, pp. 257-274.

- ⁴² K. Velmurugan, S. Suresh, S. Santhoshkumar, M. Saranya and R. Nandhakumar, "A simple Chalcone-based ratiometric chemosensor for silver ion," *The Journal of Biological and Chemical Luminescence*, no. 31, pp. 722-727, 2016.
- ⁴³ S. Kacmaz, K. Ertekin, A. Suslu, M. Ozdemir, Y. Ergun, E. Celik and U. Cocen, "Emission based sub-nanomolar silver sensing with electrospun nanofibers," *Sensors and Actuators B: Chemical*, no. 153, pp. 205-213, 2011.
- ⁴⁴ K. Wygladacz, A. Radu, C. Xu, Y. Qin and E. Bakker, "Fiber-Optic Microsensor Array Based on Fluorescent Bulk Optode Microspheres for the Trace Analysis of Silver Ions," *Analytical Chemistry*, vol. 77, no. 15, pp. 4706-4712, 2005.
- ⁴⁵ "Highly selective and sensitive fluorescent chemosensor for femtomolar detection of silver ion in aqueous medium," *Sensing and Bio-Sensing Research*, no. 6, pp. 19-24, 2015.
- ⁴⁶ T. Liu, G. Li, N. Zhang and Y. Chen, "An inorganic-organic hybrid optical sensor for heavy metal ion detection based on immobilizing 4-(2-pyridylazo)-resorcinol on functionalized HMS," *Journal of Hazardous Materials*, no. 201-202, pp. 155-161, 2012.
- ⁴⁷ R. Czolk, J. Reichert and H. Ache, "An optical sensor for the detection of heavy metal ions," *Sensors and Actuators B*, no. 7, pp. 540-543, 1992.
- ⁴⁸ J. Ueberfeld, N. Parthasarathy, H. Zbinden, N. Gisin and J. Buffle, "Coupling Fiber Optics to a Permeation Liquid Membrane for Heavy Metal Sensor Development," *Analytical Chemistry*, no. 74, pp. 664-670, 2002.
- ⁴⁹ "Selective fluorescence detection of Cu²⁺ in aqueous solution and living cells," *Journal of Luminescence*, no. 145, pp. 843-848, 2014.
- ⁵⁰ T. Mayr, "Optical Sensors for the Determination of Heavy Metal Ions: Doctoral Thesis," University of Regensburg, Regensburg, 2002.