

Omni-gravity Hydroponics for Space Exploration

Rihana M. Mungin¹ and Mark M. Weislogel²
Portland State University, Portland, OR, 97201

Tyler R. Hatch³ and John B. McQuillen⁴
NASA Glenn Research Center, Cleveland, OH, 44135

As part of the NASA Plant Water Management technology demonstration experiments, a capillary fluidics hydroponic system that can function in a variety of gravity environments has been developed and tested for crop production in space. A passive liquid delivery method is employed that drastically reduces the number of contaminable moving parts providing a high reliability solution requiring minimal resources for operation. The terrestrial, lunar, and Martian environments are managed in a ‘gravity-dominated mode,’ while the low-gravity transit and orbit environments are managed in a ‘capillary fluidics mode,’ where the role of gravity is replaced by the equally passive effects of surface tension, conduit shape, and wettability. The unique considerations for priming, germination, aeration, nutrient supply, root accommodation, layout, crew interaction, etc. are highlighted. Design guides for system function are provided along with high Technology Readiness Level demonstrations of the system during terrestrial and drop tower tests. Long duration tests are planned on short schedule aboard the International Space Station in 2019.

Nomenclature

CSELS	=	Capillary Structures for Exploration Life Support
PWM	=	Plant Water Management
0- g_o	=	‘Low-g,’ or negligible gravity level, typically microgravity levels ($9.81 \times 10^{-6} \text{ m/s}^2$)
1- g_o	=	Terrestrial gravitational acceleration (9.81 m/s^2)

I. Introduction

Food production will be a critical element for human survival beyond Low Earth Orbit. The time to effect may be shorter for oxygen, shelter, or water, but the consequences are just as serious. Stored food is a significant logistics burden for initial human missions to the Moon and Mars. Consequently, supplemental crop production methods are under investigation. Scientific experiments aboard the International Space Station (ISS) have demonstrated that plant growth in space is feasible, but is not without challenges for food production systems striving to achieve sufficient hydration and aeration to the plant root zone during the somewhat uncertain reduced-gravity growth process.¹ In addition to hydration, a plant requires water for nutrient transport, biochemical processes, and thermal management. Aeration is required to transport gases in the root zone at a minimal but necessary level. As true for most liquid systems aboard spacecraft, significant challenges arise for reliable and sustainable engineering systems tasked with the passive, semi-passive, or active delivery of liquids and gases to plants through the various stages of growth. Additionally, crew response to fresh grown food and voluntary time spent tending plants provide evidence for the benefit plants can have for future missions.²

Several methods have been proposed and employed over the years to conduct plant biology experiments and develop concepts for in-space food production systems. A soil-like system that is pre-loaded with nutrients, such as an ion-exchange³ or arcillite⁴ media, passively feed water from a reservoir. Early as well as recent soil-based systems have employed pumped systems for feeding water into porous tubes embedded in a soil media. Systems utilizing porous media or soil are representative of the typical means of growing plants terrestrially and offer similar

¹Graduate Student, Mechanical and Materials Engineering, 1930 SW 4th Ave.

²Principal Investigator, Mechanical and Materials Engineering, 1930 SW 4th Ave.

³Aerospace Engineer, Low Gravity Exploration Technology Branch, 21000 Brookpark Rd, MS 77-5

⁴Senior Aerospace Engineer, Low Gravity Exploration Technology Branch, 21000 Brookpark Rd, MS 77-5

mechanisms of distributing water in both lunar and Martian-gravitational environments. Several plant growth facilities aboard the ISS utilize these methods: Veggie,^{4,5} Passive Orbital Nutrient Delivery System (PONDS),⁶ and the Advanced Plant Habitat (APH).⁷ However, porous media for food production systems may typically be used once per plant growth cycle, which imposes potentially significant mass and storage penalties.

Hydroponic⁸ methods that recirculate nutrient-laden water have been tested as part of the development for regenerative Environmental Control and Life Support Systems for production of food and oxygen. Aeroponic⁹ systems that utilize a spray directed at roots growing in a humidified air space should be explored as an alternative to hydroponics to further reduce the necessary launch mass, despite challenges of droplet control and adequate aeration of the root zone in microgravity.¹⁰

We pursue an incremental ‘technology demonstration’ approach to low-g or ‘0-g_o’ plant watering based on the application of recent advances in capillary fluidics research conducted on ISS. Our approach is applicable for plant science studies as well as the development of space-based food production systems. We intend to demonstrate the extent to which capillary forces may be harnessed in reduced-gravity environments for hydroponic plant watering with special consideration for the critical challenges of passive saturation, aeration, de-gassing, nutrient supply, liquid stability, automation, accommodation for plant growth cycle, root growth, and more. This is achieved by exploiting passive and semi-passive control of poorly wetting capillary liquids that mimic the role of gravity for well-established terrestrial systems. Each demonstration seeks to increase complexity building on previous experiences and successes with quantitative measures of performance, regimes of operation, stability, cycling, etc.

II. The Plant Water Management Experiments

The NASA Plant Water Management (PWM) project is a fast-to-flight technology development effort to investigate water delivery methods for hydroponics and artificial soil systems for a variety of plant types in the microgravity environment. The cooperative agreement between NASA Glenn Research Center (GRC), NASA Kennedy Space Center (KSC), and Portland State University (PSU) seeks to develop crew-tended technology demonstrations simulating plant water delivery methods to satisfy objectives listed in part here:

- Demonstrate low-g role of surface tension, wetting, and system geometry to effectively replace the role of gravity in certain terrestrial soil and hydroponic plant growth systems for applications aboard spacecraft
- Provide hydration and aeration to plant root zone throughout the plant life cycle (germination through harvest)
- Provide hydration and aeration to plant root zone for single or multiple plant production chambers
- Control liquid inventory via capillary forces within either an open or semi-open container
- Provide sufficient hydration commensurate with plant growth and evapotranspiration rates
- Provide hydration and aeration to plant root zone in a geometry that can be utilized in omni-gravity environment
- Demonstrate routine prime, startup, shutdown, steady and transient operation
- Demonstrate potential for routine plant management functions: i.e., pruning, harvesting, root clearing, etc.
- Demonstrate use of flight hardware by low-g plant research community for true plant growth demonstration

Six test demonstration methods are planned with the first two scheduled for delivery to the ISS by mid-2019. The first two consist of (1) an omni-gravity hydroponics approach (PWM-H) and (2) a breathing geometric soils approach (PWM-S). Both approaches seek to leverage capillary forces, wetting, and novel geometry to provide a more passive means of control for the delivery of oxygenated nutrient-rich water to simulated plants throughout the growth cycle. PWM-H is the focus of this presentation. The PWM-H approach lays a foundation for scalable hydroponic systems in the microgravity environments of orbiting and/or coasting spacecraft. The method is also fully compatible with terrestrial, lunar, and Martian gravitational environments.

III. The PWM-H Project

The general PWM-H technology demonstration approach centers on the ready use of the Maintenance Work Area (MWA), light sources, still cameras, and live HD video downlinked cameras currently available on ISS. To simulate the liquid uptake of a typical plant, rayon felt and nylon fibers are selected to serve as wicking materials modeling the plant root, stem, and foliage. The low-humidity conditions of the ISS provide ample gradients for evaporation, leading to practical evapotranspiration rates controlled by the foliage model surface area and the known low-g evaporation rates on ISS.¹¹ During a several hour period, a single crew member can unstow, assemble, and conduct the experiments with live support from the ground team. We provide further details of the experiment design, test procedures, and

highlight supplementary ground-based experiments. In summary we report the current status and schedule of the project.

A. Hardware Design

The PWM-H test cell, test stand, and overall operational approach draws largely from the recently successful Capillary Structures for Exploration Life Support¹² (CSELS-Viscous) demonstration performed aboard ISS during Increment 52, July 2017. During the CSELS-Viscous experiments, stable high-rate parallel-path capillarity-driven flows of a poorly wetting viscous solution through open wedge-shaped conduits were demonstrated. The CSELS objectives centered on the demonstration and development of models for ‘thin’ capillary films for use in direct contact sorbent reactors for passive cabin air CO₂ scrubbing applications. In the present case of PWM-H, a similar capillary geometry is exploited, but in this case for poorly wetting aqueous solutions for low-g hydroponics applications.

Figure 1 presents a schematic and images of the ‘ice cream cone’ cross-section formed by the test cell lid and base. The ACCURA 60 SLA 3D printed transparent channel is an $\alpha = 7.5^\circ$ half-angle interior corner channel that tapers along its length. The interior corner angle is selected to provide critical geometric corner wetting conditions for liquid contact angles¹³ less than $\theta = 82.5^\circ < \pi/2 - \alpha$, which facilitates priming and recovery from disruptive events. Larger contact angles are also readily accommodated, and, though they may require more attention during system priming, they can offer unique performance advantages as recently demonstrated by Wollman.¹⁴

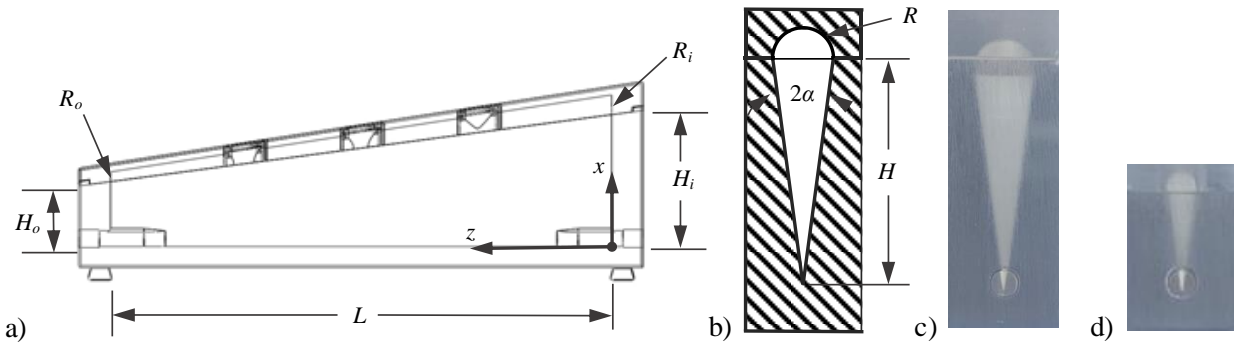

Figure 1. PWM-H Phase I test cell. a) CAD rendering of test cell with a z - x coordinate system where L is the length of the channel, H_i and H_o are the height from the vertex to the base of the lid at the inlet and outlet, and R_i and R_o are the lid radii at the inlet and outlet, respectively, and the three openings in the lid for plant placement are located 4, 7.5, and 11 cm from the inlet. b) Schematic of ice cream cone cross-section where R is the interior lid radius, H is the height from the vertex to the base of the lid, and α is the interior wedge half-angle. c) Test cell inlet $H_i = 4$ cm and $R_i = 0.53$ cm. d) Test cell outlet where $H_o = 2$ cm and $R_o = 0.26$ cm.

An image of the test cell base with lid holding three of the single tap root model plants is provided in Figure 2. An Ultem FDM 3D-printed test stand holds the test cell, fluid tubing, 0.2 to 8 mL/s peristaltic pump, and two 60 mL syringe reservoirs, as shown in Figure 3. The detachable test cell lid provides for both the plant stem support and a level of liquid confinement against inadvertent spillage during crew handling. The envelope dimensions of the test stand are 41.5 cm by 9.5 cm by 21 cm.

Figure 4 provides a separate image of a pre-assembled tubing harness with color coded fittings and valves. The harness can be quickly clipped into the test stand by the crew. Several additional test harnesses and hydroponic test cells will fly with the experiment, each being discarded after use. Luer Lock and hose barb fittings are employed throughout for the 4 mm ID Tygon tubing comprising the main harness and silicone tubing at the peristaltic pump head. The transparent hydroponic test cell is front lit using an ISS portable light source with a white background behind the test cell to quantify the free surface profile. The primary science HD video camcorder Field of View (FOV) is identified with dashed line in Figure 3a. This view provides the majority of the quantitative measures for the experiment: static and dynamic interface configurations, stability, fill level, flow rate, wetting angles, free surface response to active plant root model, evaporation rates, and more.



Figure 2. Low-g representation of 3D printed Acura 60 test cell and three rayon felt tap root plant models.

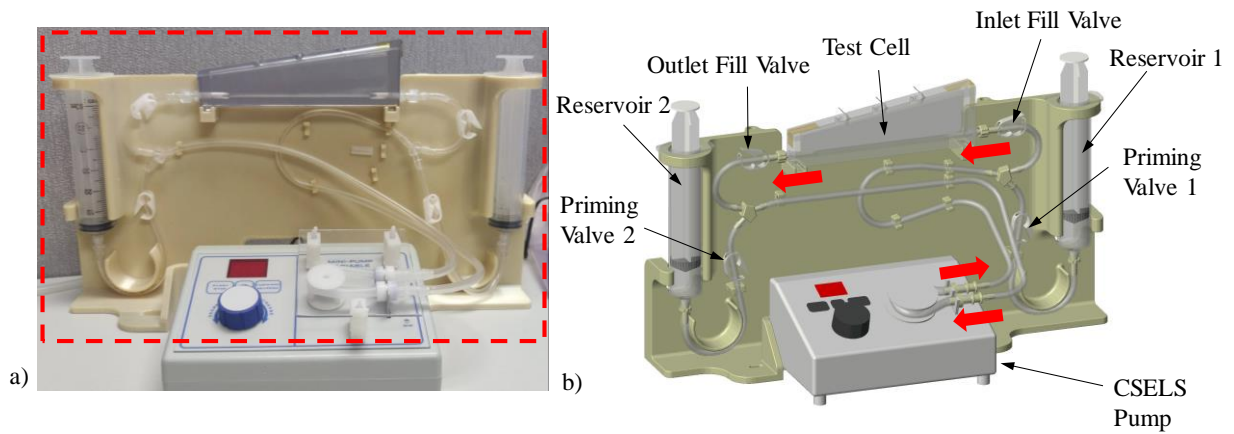

Figure 3. Assembled PWM-H experimental unit. a) Red dashed outline indicates experimental FOV with b) key elements of unit identified.

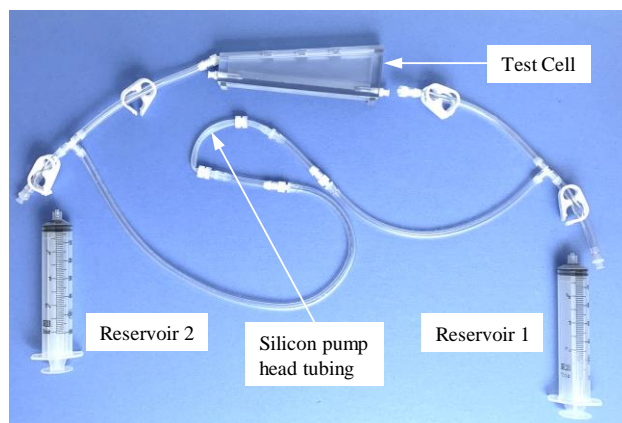

Figure 4. Pre-assembled PWM-H Tygon tubing harness. Male and female Luer Lock connectors for syringe reservoirs and hydroponic test cell. Pinch valves are located at the inlet and outlet of the hydroponic test cell and reservoir inlets.

The syringe reservoirs are used to acquire red drink from the ISS supply. They are then attached to the tubing harness and installed onto the test stand. The syringes are used to prime the system as well as measurably vary the total liquid volume within the channel during operations. Care is taken to ensure that a minimum number of bubbles are introduced into the tubing and test cell during the prime. During microgravity operation water is delivered from the pump to the test cell inlet. The liquid is driven from right to left through the test cell and across the root model(s) by the capillary (interface height) gradient.

Transition regions at the inlet and outlet of the channel extend approximately 1.5 cm into the test cell to aid even fluid distribution. The test cell is tapered to ensure that inadvertent crew perturbations to the test cell will have a passive capillary capacity to return to the interior corner with the large portion of liquid covering the outlet portion of the channel.¹⁵ The pump can then collect 100% liquid from the channel exit and re-establish the desired operating conditions. The interior length of the channel is $L = 15$ cm, the height from the vertex to the base of the lid at the inlet and outlet are $H_i = 4$ cm and $H_o = 2$ cm, the interior half-angle is $\alpha = 7.5^\circ$, and the lid radii are $R_i = 1.05$ cm and $R_o = 0.53$ cm, respectively. These dimensions are chosen as large as possible to achieve liquid delivery rates as high as ~ 8 mL/s for practical plant hydroponic models, but not too large such that the liquid in the channel will be unstable to practical system perturbations. The selected dimensions provide stability to disturbance accelerations up to $\sim \sigma/(\rho H_o L \tan \alpha) \approx 0.16$ m/s², or approximately $10^{-2}g_o$ where ρ is the liquid density and σ is the surface tension.

Knowledge of the dynamic liquid profile along the channel provides a measure of the flowrate through the channel.¹⁶ Referring to the coordinate system identified in Figure 1a, for steady flows it can be shown that for known free surface heights at the channel inlet and outlet, H_1 and H_2 respectively, the height of the free surface h along the length of the channel can be estimated by

$$h = H_1 \left(1 - \left(1 - \left(\frac{H_2}{H_1} \right)^3 \right) \frac{z}{L} \right)^{1/3}, \quad (1)$$

from which the flow rate Q may be calculated as

$$Q = \frac{\sigma F_A H_1^3}{\mu} \frac{F_i \sin^2 \alpha}{3L f} \left(1 - \left(\frac{H_2}{H_1} \right)^3 \right), \quad (2)$$

where μ is the dynamic viscosity of the liquid and θ is the contact angle. The term $F_i \approx 1/7$ is a dimensionless flow resistance parameter and F_A and f are dimensionless area and free surface curvature functions, respectively:

$$F_A = f^2 \left(\frac{\cos \theta \sin \delta}{\sin \alpha} - \delta \right) \sim \tan \alpha; \quad f = \frac{\sin \alpha}{\cos \theta - \sin \alpha}; \quad \delta \equiv \pi/2 - \alpha - \theta. \quad (3)$$

Expected flow rates for the channels are estimated using these equations with $H_2/H_1 \ll 1$ to estimate $Q_{max} \sim 10.6$ mL/s. The presence of root models is expected to retard the maximum flow rate. Exceeding Q_{max} can result in either gas bubble ingestion at the liquid outlet, or a liquid embolism at the channel inlet. Such occurrences can lead to either enhanced or degraded performance depending on other flow conditions and system objectives. Identification of the limits of stable operation of the device with integral plant model(s) is a central objective of the experiments.

Numerous PWM-H plant models for roots, stem, and foliage have been developed. Two simple examples are pictured in Figure 5. The roots act as wicks drawing liquid into and along the stem, eventually saturating the circular felt foliage. The foliage is sized to yield a practical evapotranspiration rate¹⁷ of 4 L/m²·day, based on ISS-measured evaporation rates¹¹ for water of 262.8 ± 22.7 g/hr·m². The single tap root model in Figure 5b is made from a single piece of highly wetting uncompressed 4 mm thick rayon felt. The single root is 4 mm wide and 30 mm long. A 15 mm length of heat shrink wrap surrounds the top of the root at the base of the foliage, forming a rigid ‘stem’ with a poorly wetting exterior surface that supports the foliage. The felt-string composite plant model in Figure 5c replaces the single root with 4 frayed nylon cords. The nylon cord is woven through the foliage, gathered at the base and encased in heat shrink wrap. All materials are measured for porosity, pore size, static wicking height, viscous flow resistance, and repeatable wettability following complete dryout cycles.

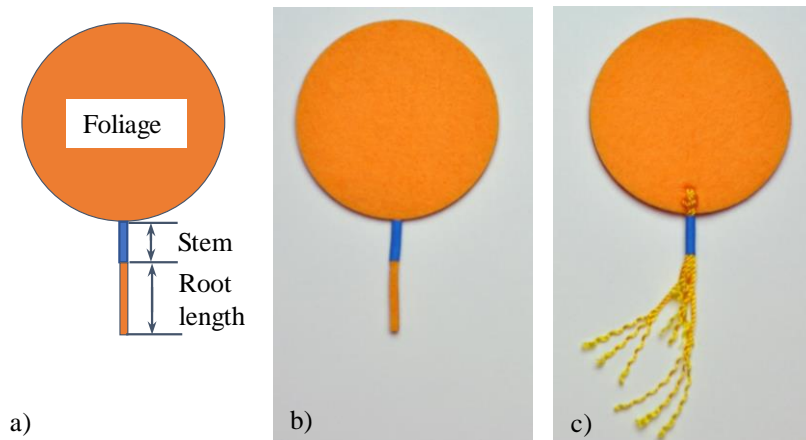

Figure 5. PWM-H Phase I plant models. A 118 mm² circular ‘foliage’ is laser cut from 4mm thick rayon felt. A 15 mm length of 6.35 mm ID heat shrink acts as a stem connecting the foliage to the root(s): a) Plant model schematic, b) single rayon tap root model, c) frayed nylon cord root model.

B. Tentative Experimental Procedures

The general spaceflight experiment procedures begin with the unstow and assembly of the PWM-H test stand, test cell, tubing harness, 60 ml syringes and peristaltic pump. The HD ISS camcorder FOV and focus will be confirmed by the ground team and the experiments initiated. The syringes are detached, filled with red drink from ISS drink bags, reinstalled on the test stand, and connected to the tubing harness. Through various operations with the valves and syringes the system is primed such that a singly connected largely bubble-free liquid rivulet is established across the channel length. The system is bubble tolerant, but we wish to begin bubble-free and work our way towards a complete bubbly two-phase flow state. The syringes are then adjusted to achieve the desired fluid fill level in the channel.

The pump is then turned on to establish base state flow conditions without a plant model present. A plant model is inserted into the center opening and the static water capillary uptake recorded. Once the plant model is saturated with liquid, the liquid level will be adjusted and pump turned on. The pump speed will then be cycled to determine the limits of operation (i.e., bubble ingestion limit). Such limits will be determined as a function of plant model, number of plant models (up to 3), channel fill level, and flow rate. Future operations propose multi-day long-duration tests to demonstrate the slow transient response of the system to ‘evapotranspiration’ through the plant model. At various stages during the operations, the crew will be asked to manually perturb the test cell to demonstrate the stability of liquid configurations. Following completion of the tests, the plant models are removed and disposed, and the remaining liquid is withdrawn from the test cell and tubing harness. Using red drink as the test fluid requires that the tubing harness and test cell are also disposed.

IV. Terrestrial and Drop Tower Tests

In parallel to the ISS flight hardware specification and development, terrestrial capillarity-dominated hydroponics systems were designed, fabricated, and tested as well as full-scale low-g systems for demonstration in a drop tower.

A. Preliminary Terrestrial 1-g_o Demonstrations

Provided the effects of gravity are small compared to those of surface tension, scaled wedge channels rotated 90° and tested horizontally can be designed to mimic the expected full-scale PWM-H model performance. One must simply achieve a low Bond number; namely, $Bo < \rho g H_s L_s \tan \alpha / \sigma$. This was achieved herein by the scaled system pictured in Figure 6. Significantly reduced gravity conditions are achieved when tested horizontally for $W_s = 3$ mm, $H_s = 16$ mm, $L_s = 60$ mm, and $\alpha = 10.6^\circ$. Scaled plant model replicas of the hydroponics test cell are shown in the figure. This test article is 3D-printed in Somos Watershed with overall dimensions of 13 mm by 36 mm by 82 mm. The ~ 3-fold reduction in size reduces the flow rate accordingly by ~ 3⁻³, and values of $Q < 0.4$ mL/s are achieved.

To effectively model the plant fluid wicking and foliage evaporation, an integrated micro-pillar textured superhydrophobic surface extends horizontally from the lower horizontal planar face of the wedge channel identified on Figure 6. The textured surface, shown in Figure 6b, is coated with CYTONIX WX-2100™ superhydrophobic spray.

All uncoated sections are masked before applying a generous coating of the spray. The coated surface dries for 24 hours establishing an approximately 160° contact angle for water on the textured surface. The coated surface prevents gravity-driven drainage from the saturated porous plant model materials and simulates the foliage suspended in air as expected in microgravity, and even allow ejections of free droplets for an embolized free surface at flow rates exceeding Q_{max} .

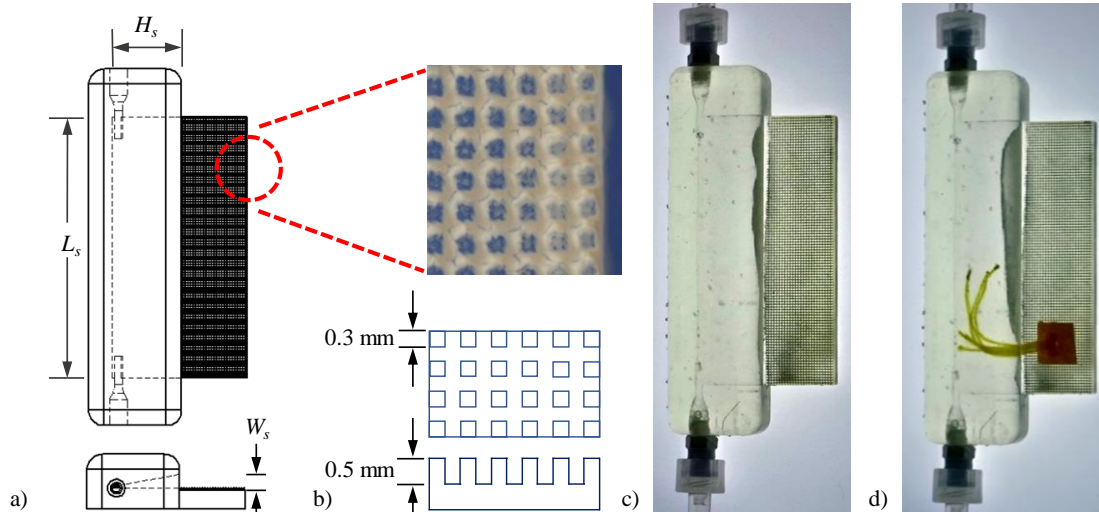

Figure 6. a) Schematic of 1-g hydroponic test cell with b) magnified view of square post microstructure surface in a) with dimensions. c) Stable flow through 1-g hydroponic test cell filled with water and with d) mini nylon root plant model.

As expected of the full-scale flight system, the scaled terrestrial devices are tested for priming, stable set points, and limits of operation as functions of fill level, plant model(s), etc. The limits of operation are under investigation varying fill level, flow rate, and plant model configuration. The limiting process of gas ingestion at the wedge channel outlet is not necessarily a negative consequence, and in fact can result in continued stable periodic bubble ingestion behavior creating a significantly aerated water supply. For example, Figure 7a shows the terrestrial system at the bubble ingestion limit. The ingested gas increases the fluid volume in the loop which expands into the inlet of the wedge channel temporarily restabilizing the system, Figure 7b. But the confined air bubbles in the entrance section of the channel are forced into each other and eventually coalesce with each other and the free surface. This lowers the liquid levels and returns the system to the bubble ingestion limit. This passive bubble separation mechanism of the wedge geometry was demonstrated to a high degree during previous ISS CCF-EU2 experiments,^{18,19} which are archived in the NASA Physical Sciences Informatics system.²⁰ Thus, the wedge channel is capable of passively ingesting and exuding bubbles in equal volumes such that stable bubbly two-phase capillary flow may be achieved, as demonstrated in Figure 7. The value of such naturally aerated low-g hydroponic flows is not overlooked. Our flight experiments seek to determine both the hydroponic operational limits of both single- and two-phase flow regimes.

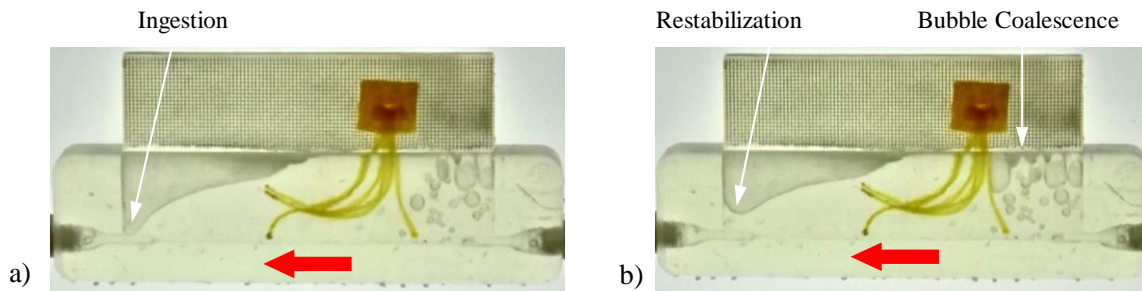

Figure 7. Top view of 1-g hydroponic test cell with mini nylon root plant model. Demonstration of periodic bubble ingestion with the flow moving from right to left. a) Unstable conditions leading to bubble ingestion with b) temporary stability due to increased volume in channel.

B. Preliminary low-g Drop Tower Tests

Due to the rapid reorientation time of the capillary liquid and the large flow rate through the PWM-H open wedge channel, full-scale tests can also be pursued using drop tower facilities. A schematic and image of the PWM-H drop tower rig is provided in Figure 8 with key elements identified. The tests are performed in a high-rate 2.1 s drop tower.^{21,22} Both static and dynamic capillary states of the channel-plant model system can be observed in such tests. Ample time is not available to establish true steady states, but certain aspects of the low-g flow configurations can be learned to develop more quantitative expectations of the flight system. For example, to note the insensitivity of the flow for low flow rates, Figure 9 displays terrestrial and low-g drop tower states for a given flow rate of contaminated water operating above the low-g ingestion limit. Minimal changes in meniscus profile are detected in part due to the high contact angle $\sim 80^\circ$, high contact angle hysteresis $50^\circ < \theta < 110^\circ$, and low inertia of the flow. In this way, if the gravity vector is oriented downward and normal to the wedge vertex along the bisecting plane, the open wedge channel hydroponic approach may be considered g-insensitive—an ‘omni-gravitational’ system. The results of a sample drop test provided in Figure 9b and d show the expected local deflections of the bulk interface due to the presence of a plant model.

A host of demonstration tests can and will be pursued further using the drop tower. Such readily conducted tests elevate the Technology Readiness Level (TRL) for the system and guide component design choices, root model geometry, material selection, and crew procedures development. Dynamic stability demonstrations can and will also be pursued.

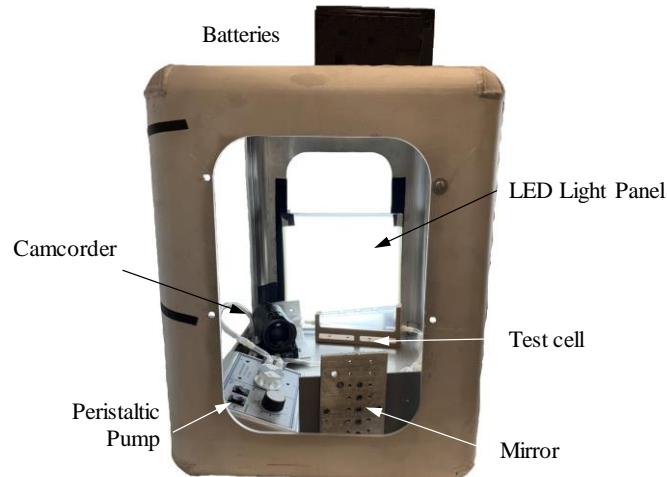

Figure 8. Drop tower experiment rig with key elements identified.

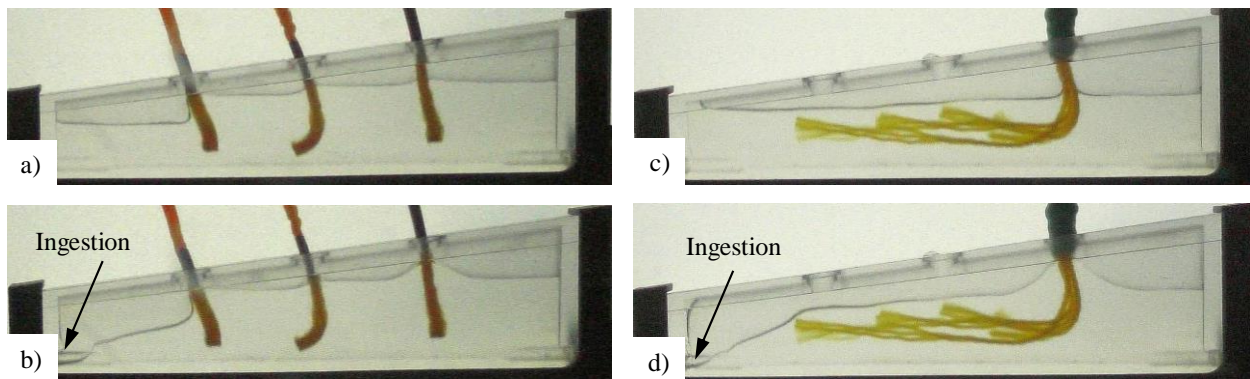

Figure 9. A sample of PWM-H results for a) 1- g_0 and b) low-g three tap root plants models and c) 1- g_0 and d) low-g single nylon root plant model. The low-g drop tower ingestion limit is exceeded for this flow rate which is right to left in the figure.

V. Status and Schedule

The goal of this technology development activity is to demonstrate the hydroponic water and nutrient delivery design and operation in low- and variable-gravity environments. Currently, the Phase I PWM experiments (PWM-H and PWM-S) are scheduled to fly to the ISS in July 2019 aboard SpaceX-18 with experiments expected to be performed shortly thereafter. Phase II of the work includes new hydroponic tests that will pursue further practical engineering demonstrations. The primary focus for the new hydroponic systems will include special considerations for seed germination and root accommodation allowing dramatic changes in root geometry and volume without sacrificing hydroponic water delivery. A study of the free surface stability for the hybrid cross-section with developing root masses simulating plant growth will follow. Phase II also offers the opportunity to demonstrate multiple hydroponic channels in parallel and assess system flow stability due to complex parallel path non-uniformity. Stable two-phase gas ingesting states will also be further pursued in the Phase II work.

Acknowledgments

This work is funded by the NASA Space life and Physical Science Division. PSU support is provided in part through NASA Cooperative Agreement 80NSSC18K0436. The PWM flight hardware development to date has been completed by Zin Technologies Inc. The authors are greatly appreciative for the insights of NASA KSC plant physiologists including Tom Dreschel, Ralph Fritsche, Gioia Massa, Oscar Monje and Ray Wheeler. Contract support was also used for student outreach experiments targeting advanced plant watering strategies using NASA GRCs 2.2 s Drop Tower. The student winners will present their results at the 2019 American Society for Gravitational and Space Research conference.

References

- ¹Steinberg, S. L., Ming, D. W., and Henninger, D., "Plant Production Systems for Microgravity: Critical Issues in Water, Air, and Solute Transport Through Unsaturated Porous Media," NASA TM-2002-210774, 2002.
- ²Dreschel, T., Nugent, M., Monje, O., and Spencer, L. E., "Hydroponics for Food Production in Space: History and Current Efforts," NTRS Database: <https://ntrs.nasa.gov/archive/nasa/casi.ntrs.nasa.gov/20180005362.pdf> 2018.
- ³Porterfield, D. M., Neichitailo, G. S., Mashinski, A. L., and Musgrave M. E., "Spaceflight hardware for conducting plant growth experiments in space: the early years 1960–2000," *Advances in Space research*, Vol. 31, No. 1, 2003, pp. 183-193.
- ⁴Massa, G. D., Dufour, N. F., Carver, J. A., Hummerick, M. E., Wheeler, R. M., Morrow, R. C., and Smith, T. M., "VEG-01: veggie hardware validation testing on the International Space Station," *Open Agriculture*, Vol. 2, No. 1, 2017, pp. 33-41.
- ⁵Massa, G. D., Wheeler, R. M., Morrow, R. C., and Levine H. G., "Growth Chambers on the International Space Station for Large Plants," *ISHS Ata Horticulturae: VIII International Symposium on Light in Horticulture*, Vol. 1134, May 2016, pp. 215-222.
- ⁶Zhang, Y., Levine, H. G., Massa, G. D., "Veggie PONDS," Space Station Research Explorer on NASA.gov, https://www.nasa.gov/mission_pages/station/research/experiments/explorer/Investigation.html?id=7581.
- ⁷Morrow, R. C., Richter, R. C., Tellez, G., Monje, O., Wheeler, R., Massa, G., Dufour, N., and Onate, B., "A New Plant Habitat Facility for the ISS," *46th International Conference on Environmental Systems*, ICES-2016-320, 10-14 July 2016, Vienna, Austria.
- ⁸Stutte, G. W., "Process and Product: Recirculating Hydroponics and Bioactive Compounds in a Controlled Environment," *HortScience*, Vol. 41, No. 3, 2006, pp. 526-530.
- ⁹Clawson, J. M., Hoehn, A., Stodieck, L. S., Todd, P., and Stoner, R. J., "Re-examining Aeroponics for Spaceflight Plant Growth," *SAE Technical Paper*, No. 2000-01-2507, Jul. 2000.
- ¹⁰Morrow, R. C., Wetzel, J. P., Richter, R. C., Crabb, T. M., "Evolution of Space-Based Plant Growth Technologies for Hybrid Life Support Systems," *47th International Conference on Environmental Systems*, ICES-2017-301, 16-20 July 2017, Charleston, South Carolina.
- ¹¹Mungin, R., Weislogel, D. Ringle, M., Callahan, M., Chen, Y., Sargusingh, M., Evaporation in Microgravity: Recent Results from the ISS CSELS Experiment, 34th Ann. Mtg. American Soc. for Gravitational and Space Research, ID-271, Bethesda, Oct. 31-Nov. 3, 2018.
- ¹²Viestenz, K. J., Jenson, R. M., Weislogel, M. M., Sargusingh, M. J., "Capillary Structures for Exploration Life Support Payload Experiment," *48th International Conference on Environmental Systems*, ICES-2018-241, 8-12 July 2018, Albuquerque, New Mexico.
- ¹³Concus, P., Finn, R., "On the Behavior of a Capillary Surface in a Wedge," *Proceedings of the National Academy of Sciences of the United States of America*, Vol. 63, No2, 1969, pp. 292-299.
- ¹⁴Wollman, A., "Large Length Scale Capillary Fluidics: From Jumping Bubbles to Drinking in Space," Ph.D. Dissertation, Department of Mechanical and Materials Engineering, Portland State University, DOI 10.15760/etd.2914, 2016.
- ¹⁵Weislogel, M. M., Baker, J. A., Jenson, R. M., "Quasi-Steady Capillarity-Driven Flows in Slender Containers with Interior Edges," *J. Fluid Mech.*, Vol. 685, Jul. 2011, pp. 271-305.
- ¹⁶Weislogel, M. M., "Capillary Flow in an Interior Corner," NASA TM-107364, Nov. 1996.

¹⁷Wheeler, R. M., “Potato and Human Exploration of Space: Some Observations from NASA-Sponsored Controlled Environment Studies,” *Potato Research*, Vol. 49, Feb. 2006, pp. 67-90.

¹⁸Conrath, M., Canfield, P. J., Bronowicki, P. M., Dreyer, M. E., Weislogel, M. M., Grah, A., “Capillary channel flow experiments aboard the International Space Station,” *Physical Review E*, Vol. 88, No. 6, 2013, pp. 063009-1 - 063009-8.

¹⁹Jenson, R. M., Wollman, A. P., Weislogel, M. M., Sharp, L., Green, R., Canfield, P. J., Klatte, J., Dreyer, M. E., “Passive Phase Separation of Microgravity Bubbly Flows using Conduit Geometry,” *Int. J. Multiphase Flow*, Vol. 64, Jun. 2014, pp. 68-81

²⁰NASA Physical Sciences Informatics Database: <https://psi.nasa.gov/> (See CCF-EU2 data)

²¹Wollman, A., Weislogel, M., “New Investigations in Capillary Fluidics Using a Drop Tower,” *Experiments in Fluids*, Vol. 54, No. 4, Apr. 2013, p 1499, See also URL: <https://www.pdx.edu/dryden-drop-tower/>

²²Wollman, A., Weislogel, M., Wiles, B., Pettit, D., Snyder, T., “More Investigations in Capillary Fluidics Using a Drop Tower,” *Experiments in Fluids*, Vol. 57, No. 4, Mar. 2016, 17 pages.