

A decision-support model for selecting additive manufacturing versus subtractive manufacturing based on energy consumption

J.K. Watson*¹, K.M.B. Taminger²

Abstract

This paper presents a simple computational model for determining whether additive manufacturing or subtractive manufacturing is more energy efficient for production of a given metallic part. The key discriminating variable is the fraction of the bounding envelope that contains material – i.e. the volume fraction of solid material. For both the additive process and the subtractive process, the total energy associated with the production of a part is defined in terms of the volume fraction of that part. The critical volume fraction is that for which the energy consumed by subtractive manufacturing equals the energy consumed by additive manufacturing. For volume fractions less than the critical value, additive manufacturing is more energy efficient. For volume fractions greater than the critical value, subtractive manufacturing is more efficient.

The model considers the entire manufacturing lifecycle – from production and transport of feedstock material through processing to return of post-production scrap for recycling. Energy consumed by processing equipment while idle is also accounted for in the model.

Although the individual energy components in the model are identified and accounted for in the expressions for additive and subtractive manufacturing, values for many of these components may not be currently available. Energy values for some materials' production and subtractive and additive manufacturing processes can be found in the literature. However, since many of these data are reported for a very specific application, it may be difficult, if not impossible, to reliably apply these data to new process-material manufacturing scenarios since, very often, insufficient information is provided to enable extrapolation to broader use.

Consequently, this paper also highlights the need to develop improved knowledge of the energy embodied in each phase of the manufacturing process. To be most valuable, users of the model should determine the energy consumed by their manufacturing process equipment on the basis of energy-per-unit-volume of production for each material of interest – considering both alloy composition and form. Energy consumed during machine idle per unit time should also be determined by the user then scaled to specific processing scenarios. Energy required to generate feedstock material (billet, plate, bar, wire, powder) must be obtained from suppliers.

*corresponding author

¹NASA Headquarters, 300 E St. SW, Washington, DC 20546, j.k.watson@nasa.gov

²NASA Langley Research Center, Hampton, VA 23681, karen.m.taminger@nasa.gov

1. Introduction

A wide variety of factors must be considered when selecting a manufacturing approach for a given product. Clearly, cost is a major concern – both the capital cost of processing equipment and the incremental cost of production operations. Quality issues such as surface finishes, internal defects, and mechanical properties are also of paramount importance. In recent years, there has been increased recognition of the importance of effectively utilizing resources that are consumed during manufacturing from the perspectives of cost and sustainability.

Improving “material efficiency” – reducing consumption of materials and energy in manufacturing operations – is important for extending the period of availability of mineral reserves and for reducing energy consumption in manufacturing operations and the greenhouse gases that are associated with generation of that energy (Allwood et al., 2011). Known mineral reserves are sufficient to support demand for some metals for decades and others for centuries (Kesler, 2007). Nevertheless, conservation is important since reserves are not limitless and demand will grow as the economies of developing countries expand. Increased pressure to reduce consumption of energy and water associated with mining and extraction operations can be expected to increase costs or reduce availability (Mudd and Ward, 2008). Therefore, efficient utilization of feedstock material can be expected to be a growing factor in reducing future manufacturing costs.

Manufacturing operations consume significant quantities of energy. Data recently published by the U.S. Energy Information Administration show annual consumption of energy by the fabricated metals sector at more than $59E+15$ J ($56E+12$ BTUs) in “process energy” for machine drive functions such as operation of pumps and fans, providing compressed air, materials handling functions, materials processing, and other systems. This energy is associated with generation and release of $9.8E+6$ MT CO₂-equivalent (EIA, 2014). Energy used in the production of feedstock material used in manufacturing is not included in these figures.

Additive manufacturing is viewed as one approach to improving material efficiency (Morrow et al., 2007; Reeves, 2009). Parts that are built from feedstock material – metal powder or wire – require little more than the material that is required in the final product. Other than removal of relatively small amounts of excess material during final machining to achieve precise dimensions, tolerances, and surface finishes, little, if any, waste material is generated during manufacturing – assuming that any unconsolidated feedstock material can be directly reused.

The family of additive manufacturing processes is particularly attractive for material-efficient production of items that would otherwise have a high “buy-to-fly ratio” (Kobryn et al., 2006). The buy-to-fly ratio is simply the ratio of the mass of the starting billet of material to the mass of the final, finished part. Figure 1 illustrates buy-to-fly ratio, where the left image was the starting billet of material, the center image is the rough machined part and the right image is the final part. Thus, the buy-to-fly ratio is the comparison of the mass of the starting billet (left) to the final part (right).

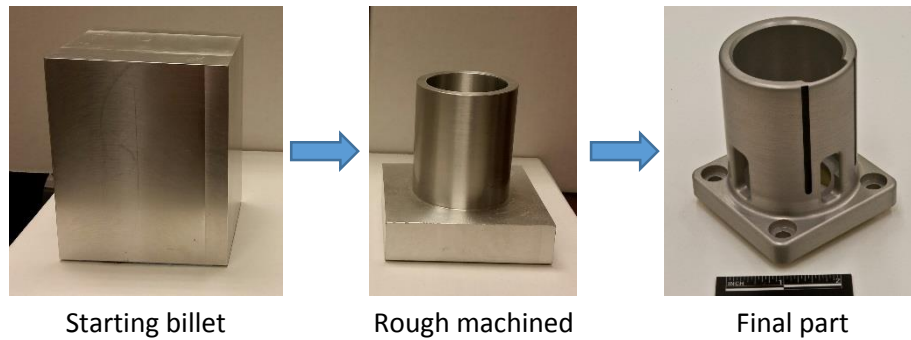

Figure 1. Machining steps from start to finish illustrate the concept of “buy-to-fly” ratio.

Buy-to-fly ratios of 10-to-1 are common in aerospace applications – meaning that only 10 percent of the original material that is acquired remains in the final part – when parts are produced by traditional subtractive manufacturing processes (Kobryn et al., 2006). High buy-to-fly ratios are encountered when the geometry of the final part requires a large billet of material, sized by the extreme dimensions of the part, but most of this volume is removed and discarded using conventional subtractive manufacturing. For example, stiffened plates with integrally machined stiffeners – as depicted in Figure 2 - start as a solid block from which large pockets of material are removed to reduce the weight of the part but retain the strength and stiffness required for the specific application. If the same part can be produced starting from a thinner plate and building up the stiffeners using additive manufacturing processes, the net buy-to-fly ratio would be significantly lower than the subtractive manufactured counterpart.



Figure 2. Large plate with integrally machined stiffeners. NASA photo 1966-02109L.

Intuitively, it seems apparent that the production of a part by subtractive manufacturing that requires removal of most of the material from a billet would be more energy-expensive than additive manufacturing. Conversely, in cases where very little material is removed, subtractive manufacturing might consume less total energy. There will be instances where subtractive manufacturing is the lowest cost, fastest, lowest energy-input option, and there will be other instances when additive manufacturing is the lowest cost, fastest, lowest energy-input. A tool to help decide which approach consumes less energy for production of a specific part would assist engineers in selecting the appropriate manufacturing process.

In the following sections, the energy consumption associated with additive manufacturing and with subtractive manufacturing is considered. In both cases, the energy consumption at all stages of the production life cycle - including the energy consumed in producing starting materials (e.g., billet, forging, plate, or feedstock for additive manufacturing) through manufacturing operations leading to the finished part – are considered. The energy required for transportation of feedstock material and scrap or residual material for recycling is also considered. Accounting for energy consumption in all life cycle stages is essential (Huang et al., 2015). Finally, a simple model that can be used to assist in the selection of the more energy-efficient approach is presented.

2. Energy Consumption in Subtractive Manufacturing and Additive Manufacturing

2.1 Subtractive Manufacturing Energy Consumption

Subtractive manufacturing includes all processes that generate a final product, or intermediate-stage product, through the removal of material. Examples of some of the processes included in this category are drilling, turning, milling, boring, broaching, and grinding.

During metal removal processing, energy is required for operation of motorized spindles and other positioning equipment and the metal removal process itself. The energy consumption and power demands vary widely across processes and are also unique to each specific processing machine (Dahmus and Gutowski, 2004; Yoon et al., 2014). The power demand during processing varies depending on the production rate of the machine, the material being processed, and specific processing parameters such as spindle rates, feed rates and cutting tool configuration (Gutowski et al., 2004; Diaz et al., 2009).

Machine tools that are used for subtractive manufacturing operations generally consume a substantial amount of energy when they are in an operating condition where they are ready to process material but are not actually doing so. The energy is required to operate such things as motors in a stand-by state, pumps to move coolant liquids, pumps for oil pressurization, lights, equipment, computers, and fans (Gutowski et al., 2004). This is non-productive consumption of energy. It is important to minimize the time during which the machine tool is in this non-productive operating state if attempting to minimize total energy consumption.

2.2 Additive Manufacturing Energy Consumption

There is growing recognition of the potential advantages of Solid Freeform Fabrication processes for enabling more sustainable manufacturing through reduced consumption of energy and materials. Additive manufacturing includes all processes that generate a final product, or intermediate-stage product, through the building up of feedstock onto a substrate. Examples of some of the processes included in this category are direct laser powder fed processes (LENS-Laser Engineered Net Shaping, LAMP-Laser-Aided Manufacturing Processes, DMD-Direct Metal Deposition), laser powder bed processes (SLM-Selective Laser Melting, SLS-Selective Laser Sintering, DMLS-Direct Metal Laser Sintering), direct electron beam wire fed processes (EBF³-Electron Beam Freeform Fabrication, EBAM-Electron Beam Additive Manufacturing), and electron beam powder bed processes (EBM-Electron Beam Melting).

During metal additive manufacturing processing, energy is required for delivering feedstock material, obtaining and maintaining the proper thermal and atmospheric background conditions, powering motors for positioning sample stages and/or beam delivery systems, high power beam for melting the metal feedstock, and integrated sensors and controllers for monitoring and controlling the build process. Additive manufacturing processes have all of these subsystems in one form or another; the energy consumption and power demands vary widely across processes and are also unique to each specific processing machine. This can make it difficult to directly compare processes with each other without a tool to capture all of the pertinent differences and the energy consumption associated with each.

In considering additive manufacturing of metal parts, the power levels and types of sources used to fuse layers together are considerably higher than those used for polymeric parts due to the higher thermophysical properties associated with metals. Thus, it is often assumed that the subsystem in metal additive manufacturing equipment with the highest power usage is the high power beams (e.g. laser or electron beam) used to melt the feedstock and fuse the layers together. The energy consumed by the high energy beam subsystems during deposition is considered the productive operating state. However, multiple studies have measured the energy usage of the different subsystems in additive manufacturing systems and have widely varying results. These auxiliary processing steps include atmospheric controls such as pumps for removing air from the system (e.g. vacuum pumps in electron beam systems which operate in a high vacuum environment, and inert atmosphere gloveboxes operating in inert environments such as argon or helium, or non-oxidizing environments such as nitrogen). Some systems also include heaters to maintain constant temperatures to manage thermal residual stresses created by high thermal gradients, or to preheat the substrate to facilitate improved adhesion of the deposited layer to the substrate. Material delivery subsystems in powder beds include a powder hopper and spreader or recoater bar to spread layers of powder; finer deposition geometries are driving to finer diameter powders and thinner layers, at the expense of additional time and energy expended for dramatically increasing the number of layers required to build a part (Baumers et al., 2010; Yoon et al., 2014; Kellens et al., 2010). These auxiliary subsystems contribute to significant percentages of time and energy invested, which could be considered non-productive or idle times. To maximize the energy efficiency in additive manufacturing processes, it is imperative to minimize non-productive operating state if attempting to minimize total energy consumption.

One solution that has been shown to reduce the energy input per part is to build multiple parts at one time instead of building one part at a time within a powder bed build volume. Nesting parts to use entire build volume in powder bed processes averages idle times across multiple parts, so the net energy per part is effectively reduced. (Baumers et al., 2011) Thus, planning for effective packing of parts on a build plate is also important to minimizing the total energy expended during additive manufacturing processes.

Direct comparison of the true energy efficiency of various additive manufacturing processes based upon the literature is not straightforward for the following reasons:

1. The materials used and their associated thermophysical properties (e.g. heat of fusion, heat capacity) are not the same between studies and, often, not the same within a study.
2. Studies may be specific to a particular part design making it difficult to generalize the results.
3. Energy consumption varies widely and is highly dependent upon the manufacturing process, the specific machine being used, the material being processed, and the specific processing parameters that are employed (Dahmus and Gutowski, 2004; Baumers et al., 2010).
3. Processing parameters (e.g. electron beam power, laser beam power, beam scan rates, powder bed temperature) are not necessarily optimized or consistent from one part to the next or from one machine to the next.
4. For laser or electron beam processes the rated output power (i.e. the power transmitted via the beam) is quoted but the required input power is not addressed. As a result, the energy conversion efficiency of the system is not considered.
5. Results may be reported as total energy consumed (e.g. kW-h, J) during deposition but not normalized on a volumetric or mass basis (e.g., J/cm³, kW-h/cm³ or kW-h/g) making it difficult to apply the results to new cases. Alternatively, operating power level may be reported but operating time and volume (or mass) deposited is not.
6. Reported results often focus on the deposition process itself and do not consider energy-consuming steps in the manufacturing process before and after deposition. However, the significance of the energy embodied in the feedstock material as well as all energy consumption by the deposition system or machining system have been recognized (Gutowski et al., 2006).

Just as with subtractive manufacturing, when assessing the total energy required to produce a part via additive manufacturing, it is necessary to consider the entire production lifecycle not just the additive process itself. Thus, the energy required to produce the feedstock (e.g. powder, wire), transport feedstock to the manufacturing site, feedstock usage efficiency, and transport scrap for recycling or disposal must also be considered. This results in a more direct comparison of total energy expenditure per part between additive and subtractive manufacturing processes.

3. Model Development

Because of the wide ranges of reported energy consumption for various subtractive and additive manufacturing processes, and recognizing that actual energy consumption is dependent upon the

specific processes, machines, and materials involved, a general model that can accommodate situation-specific information can be very useful for making informed decisions about which manufacturing approach to select to minimize energy consumption. As noted previously, to give the complete picture, it is necessary that the model capture all energy invested in the final part – from initial production of feedstock material, through processing, to return of post-processing scrap material for recycling. These activities cannot be ignored nor assumed to be equivalent regardless of the manufacturing process. For example, the energy required for shipping raw materials to the manufacturing facility will depend upon whether the material is in the form of bulk material (e.g., billets or plates) or in the form of feedstock material for additive manufacturing processes (e.g. metal powder or wire). Because of the wide range of energy consumption values reported for various processes, processing machines, processing parameters, and feedstock materials, it is necessary that actual values be used that apply to the specific candidate processing operations.

Similarly, the shipment of scrap material to recycling must be captured and the amount attributable to each finished part will depend on the part geometry and the manufacturing approach that is employed. The energy required for transporting machining scrap for recycling could be avoided if the scrap is locally transformed into feedstock material for subsequent additive manufacturing. However, for realization of a net energy benefit, the energy required for local reprocessing must be less than the energy required for transportation of the scrap and remote reprocessing. The challenge in remote processing of powder for additive manufacturing feedstock is the quality required. If recycled material such as machining chips are broken down via mechanical means, such as ball milling, the resulting powder is very angular and does not feed well. This can result in porosity, voids, and other flaws in the additive manufactured parts (Sparks and Liou, 2008). Spherical powder improves the flow characteristics, thereby reducing flaws in additive manufactured parts. However, reprocessing machining chips into spherical powder has many other challenges and requires significant investment in processing equipment; in order to obtain optimal yield and powder quality, it is typically more efficient to use vendors specifically set up for powder production (Dawes et al., 2015). The one area where recycling and reprocessing on-site may be cost and energy effective is reusing powder that has been run through the additive manufactured machine, particularly for powder bed processes. Depending on the alloy and the additive manufacturing process being used, some researchers have reported no problems with reusing powder multiple times (Carroll et al., 2006), whereas others have reported changes in particle size distribution, particle agglomeration and satellite pick-up, loss of alloying elements, and oxygen pick-up (Sparks and Liou, 2008). Depending upon the application and material quality requirements, the viability of reusing powder in additive manufacturing systems has still not been entirely determined; regardless, even if powder is directly reused, there is some energy consumption involved with collection, cleaning, sieving, and characterizing the reused powder that needs to be captured to accurately reflect energy expended when handling scrap for both additive and subtractive processes.

To be able to make direct comparison of energy efficiencies between additive and subtractive processes, it is useful to establish a common framework that can describe all energy inputs on a common basis. A very useful quantity, the "solid-to-cavity volume ratio", has been defined as the mass of the final part divided by the mass that would be contained within the bounding volumetric envelope of the part (Morrow et al., 2007). However, use of a mass-based definition for a quantity that is expressed in volumetric terms might lead to some confusion. For example, if 50 percent of

the volume of a part's bounding envelope is solid material and the other 50 percent is void or cavity, the literal calculation based on the nomenclature of the "solid-to-cavity volume ratio" would yield a value of 1.0. In actuality, the value of the quantity that would be calculated per the definition (in terms of mass) would be 0.5. Further, if a component has no void space at all - i.e. the entire envelope is occupied with material - then the literal "solid-to-cavity volume ratio" would be infinite since the denominator of the ratio would be 0.0. This is illustrated in Figure 3. If calculated per the mass-based definition the value would be 1.0.

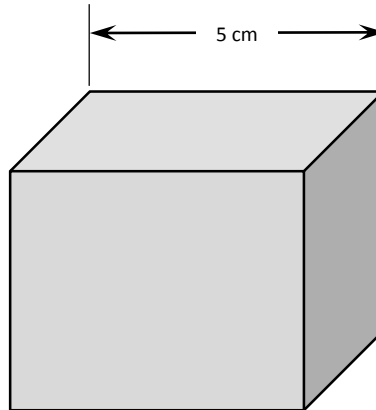

Figure 3. The solid volume of this object is 125 cm^3 . Since there is no cavity in this object, the cavity volume is 0 cm^3 . Therefore, the "solid-to-cavity" ratio, if calculated literally, would be:
 $125 \text{ cm}^3 / 0 \text{ cm}^3 = \infty$

To avoid confusion, it might be more appropriate to use the term "solid-to-envelope ratio" – referring to the volume of solid material within the bounding volumetric envelope of the part. With this minor adjustment of terminology, this quantity can serve as a valuable independent variable for determining whether conventional subtractive manufacturing or additive manufacturing is most energetically efficient in terms of total energy required to produce the final product part. The symbol " α " is used to represent the solid-to-envelope ratio. This concept is illustrated in Figure 4.

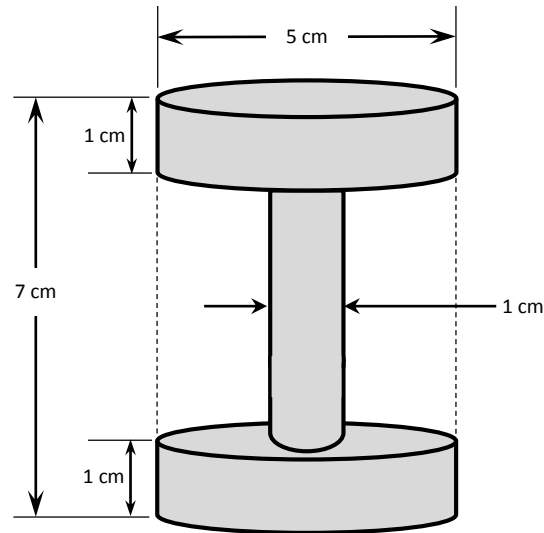

Figure 4. The volume of the solid material is approximately 179.07 cm³ while the volume of the bounding cylindrical envelope is approximately 549.8 cm³. Therefore, the “solid-to-envelope ratio”, α , is calculated as: $179.07 \text{ cm}^3 / 549.8 \text{ cm}^3 = 0.326$

There are a number of additional quantities that must be included in calculation of the energy required for additive manufacturing and for subtractive manufacturing. These quantities are defined in Table 1.

Table 1

Definition of quantities

V_M	volume of deposited material
V_T	volume defined by part envelope
α	fraction of part envelope containing solid material - the "solid-to-envelop ratio" (V_M/V_T)
E_{VD}	energy/unit volume of deposited material
E_{VM}	energy/unit volume for removal by machining
f	fraction of deposited material removed by machining
ρ	density of material
E_T	energy/kg-km for transporting material
E_F	energy/kg for production of feedstock
E_B	energy/kg for billet production
x_F	distance that feedstock is transported

x_B	distance that billet or plate is transported
x_S	distance that scrap is transported for recycling

As described earlier, to capture the entire energy expenditure associated with fabrication of any component, the full cycle from feedstock generation to capture and shipping of discarded materials should be included. The quantities defined in Table 1 are used to define terms that represent the energy consumed in each stage of the end-to-end lifecycle of a product (except energy consumed during operation of the product). These terms are defined in Table 2 and utilized in Equations 1 and 2 to account for the total life-cycle energy associated with additive manufacturing, subtractive manufacturing, and transport of the manufacturing scrap material for recycling.

Table 2

Definition of terms

$\alpha V_T E_{VD}$	energy for deposition
$f \alpha V_T E_{VM}$	energy for final machining
$\rho \alpha V_T E_T x_F$	energy for transport of feedstock
$\rho \alpha V_T E_F$	energy for production of feedstock
$f \alpha V_T \rho E_T x_S$	energy for transport of scrap from finish machining of deposited material to recycling
$\rho V_T E_T x_B$	energy for transport of billet or plate
$\rho V_T E_B$	energy for production of billet or plate
$(1-\alpha) V_T E_{VM}$	energy for machining of metal removed from billet or plate
$(1-\alpha) V_T \rho E_T x_S$	energy for transport of metal removed from billet or plate to recycling

Thus, an expression for the energy required for additive manufacturing can be defined as:

$$E_D = \rho \alpha V_T E_F + \rho \alpha V_T E_T x_F + \alpha V_T E_{VD} + f \alpha V_T E_{VM} + f \alpha V_T \rho E_T x_S \quad (1)$$

The corresponding expression for the energy required for subtractive manufacturing is:

$$E_M = \rho V_T E_B + \rho V_T E_T x_B + (1-\alpha) V_T E_{VM} + (1-\alpha) V_T \rho E_T x_S \quad (2)$$

To be most valuable in the comparison of subtractive to additive processes, the values entered into the expressions must be specific to the particular processes of interest and the specific processing machines that will be used.

The energies required for deposition and machining, E_{VD} and E_{VM} , each include not only the energy directly consumed by the additive process or the machining process, but also the energy consumed by the processing equipment during overhead operations such as start-up, repositioning, or other idle time. These non-productive components of energy consumption can be very substantial and can be equal to or greater than the energy consumed by the actual material processing action. Values for E_{VM} , which is material-specific and machine-specific, can be estimated by experimentally measuring the constant energy consumed by the machine to operate pumps, fans, computers and other ancillary equipment when the machine is operating but not processing material and also measuring the additional energy consumed per unit volume of each material that might be processed as described by Dahmus and Gutowski (2004). A similar approach could be utilized for estimating E_{VD} to include associated non-productive energy consumption during additive manufacturing.

It is important to recognize that the energy per unit volume of deposited material, E_{VD} , is the energy input to the processing equipment during deposition - not just the outgoing energy introduced into the feedstock material. Kellens et al. (2010) measured the power consumed during a build, determining which subsystems' power consumption were constant (such as nitrogen circulation, cabinet cooling, computer) and which subsystems' power consumption were dependent upon the operation being executed (such as the laser unit, process chamber heating, and coater). The power consumption was summed, then averaged over the duration of the productive modes of the build (productive modes included all of the operations during a build; non-productive modes were associated with operations such as cooling after completion of a build and chamber cleaning). The average power consumption was measured for different layer thicknesses to determine an approximation for the energy consumed per unit of volume of material deposited, E_{VD} . This approach provides a direct measurement of power consumed during the deposition process which inherently includes all of the operations during the deposition process, not just the beam power during the melting portion of the process. Direct measurement of the energy consumed also captures the losses associated with conversion of utility electrical energy to processing energy, which is vital to be factored into the total energy expenditure associated with a specific process. For example, Kellens et al. (2010) determined in one of their systems that the laser unit accounted for nearly 60% of the total energy consumed, even when the power was off (due to the continuous cooling required for the laser unit).

Intuitively, if a high percentage of the total envelope is solid material then starting with bulk material (i.e. plate, bar, or billet) and using subtractive processes to remove relatively small amounts of material to achieve required dimensions and surface finishes should require less energy than building the part with additive manufacturing processes. Conversely, if a small fraction of the envelope is occupied by material, then it may be energetically more economical to build the product part via additive manufacturing processes than it would be to start with bulk material and machine away everything not contained within the product part. This suggests that there will be a threshold value of the solid-to-envelope ratio (which is henceforth designated as " α_{crit} ") below which additive manufacturing will be most efficient and above which subtractive manufacturing will be most efficient. An expression for α_{crit} can be developed by setting the expressions for E_D and E_M equal and solving for α .

The energy required to transport the feedstock material from its point of origin to the manufacturing facility and the energy required to transport scrap material to a recycling location are included. However, it is assumed that all processing (machining and additive processes) occurs in

the same facility so there is no transportation energy required between these major processing steps. These models also assume that no heat treatment of the final product is required. Terms could easily be added to account for additional transportation or heat treatment if necessary. However, heat treatment would likely be required regardless of whether the part was produced via subtractive or additive processes; in that instance, the absolute magnitude of the energy expended would be increased by similar amounts. This will impact the total energy expended, but the terms will cancel each other out when added to both E_D and E_M then solved for α .

To find the expression for the critical value of the volume fraction, α_{crit} , the expression for the energy for additive manufacturing and the expression for the energy for subtractive manufacturing can be set equal and solved explicitly for α . The resulting expression is:

$$\alpha_{crit} = \frac{\rho V_T [E_B + E_T (x_B + x_S)] + V_T E_{VM}}{\rho V_T [E_F + E_T (x_F + f x_S + x_S)] + V_T [E_{VD} + E_{VM} (f + 1)]} \quad (3)$$

For a part with a value of α greater than α_{crit} , subtractive manufacturing will be more energy-efficient. For a part with a value of α less than α_{crit} , additive manufacturing will be more energy-efficient.

Because the values for the energy per unit volume for deposition and machining incorporate approximations of the non-productive energy consumption, the value obtained for α_{crit} will be approximate as well. If the α value for a specific part is substantially greater than or less than the computed value of α_{crit} , then using α_{crit} as the discriminating metric is useful for determining whether additive or subtractive manufacturing processes are more energy-efficient.

If the α value is very close to α_{crit} then determining which approach requires less total energy would require separation of the productive and non-productive components of energy consumed and those values be inserted into both the additive and subtractive manufacturing energy equations to evaluate explicitly which yields the lower total energy value. If this approach is taken, then equations 1 and 2 are modified to account explicitly for the energy consumed during non-productive operations (e.g., set-up, positioning, idle). The values for these non-productive expenditures of energy could be obtained for the specific item that is to be manufactured through measurement of power consumption during non-productive operations and simulations of the manufacturing processes. Equation 1 would become:

$$E_D = \rho \alpha V_T E_F + \rho \alpha V_T E_T x_F + \alpha V_T E_{VA} + f \alpha V_T E_{VS} + E_{ID} + E_{IMA} + f \alpha V_T \rho E_T x_S \quad (1a)$$

The variables E_{ID} and E_{IMA} represent the idle, or non-productive, energy associated with the deposition process and the finish machining of the deposited structure, respectively. The variable E_{VA} is the productive energy consumed per unit volume of material added and E_{VS} is the productive energy consumed per unit volume of material subtracted.

The corresponding expression for the energy required for subtractive manufacturing - where E_{IMS} is the non-productive energy associated with the subtractive manufacturing process - is:

$$E_M = \rho V_T E_B + \rho V_T E_T x_B + (1 - \alpha) V_T E_{VS} + E_{IMS} + (1 - \alpha) V_T \rho E_T x_S \quad (2a)$$

In the general case, the values for E_{VS} will be different in equations 1a and 2a unless the same machines are used for subtractive manufacturing and finish machining of an additive product. However, the case where the same machine tool would be used for both purposes is expected to be the exception rather than the rule, and the relative amount of material being removed is likely to be different between a rough and finishing machining step as compared to finish machining an additively manufactured part.

When the non-productive energy quantities are discretely considered in this way, the two equations cannot be set equal and solved for α_{crit} . This is because the non-productive energy consumed is a function of the geometry of the part being manufactured – both volume fraction and complexity - and therefore not independent of α .

4. Discussion

For the relationships presented above to be of greatest use, it is essential that the values for processing energy be specifically related to the individual processing machines and processing parameters that will be utilized and for the specific materials that will be processed. The productive energy consumed per volume of material processed should be measured experimentally, or calculated by measuring the energy consumed during processing of a similar material and part, and dividing by the volume of material added or removed. The productive energy consumed during processing of a specific part can then be determined based on the volume of material that will be added or subtracted. The non-productive power (non-productive energy consumed per unit of time) should also be measured directly. The amount of time during which non-productive energy is consumed can be determined through simulation of the manufacturing sequence – allowing calculation of total non-productive energy consumption.

Because energy is still consumed while the processing machinery is in a non-productive operating status, the total energy consumed per part can be decreased by increasing throughput rate and minimizing nonproductive operating time. This can be accomplished by considering the arrangement of components to minimize the time required for repositioning and by careful planning of the sequence of processing steps. Increasing the production rate by minimizing non-productive time reduces the portion of the constant background energy consumption attributable to each unit produced. This is true for both additive and subtractive manufacturing operations.

The energy associated with transportation should be determined for the transportation mode utilized. A representative value for heavy duty freight trucking is approximately $2E+3$ J/kg-km (Eom et al., 2012). It is necessary to use a standard value unless all transportation is accomplished with one particular vehicle – in which case a value that is specific to that vehicle could be calculated.

The expression for additive manufacturing processes can also be used as a tool to compare the energy efficiency of two different additive processes for making a given part. This approach is similar to that employed previously to compare the relative energy embodied in parts produced by injection molding and selective laser sintering (Telenko and Seepersad, 2010). In that instance, equation 1 may be used to directly calculate the energy expended for each additive manufacturing process and the net values can be compared to assess which process offers greatest energy efficiency. It is important to include all of the energy terms, since different processes will not only

differ by the direct energy consumed by the deposition equipment, but will also vary because of different feedstock forms (sizes of powder and/or wire), amount of material to be removed to attain the final geometry (measuring the amount of machining required to remove overbuild and bead width to obtain the final part), and feedstock usage efficiency (Kellens et al., 2010).

This comparative model does not necessarily serve as a direct proxy for the associated greenhouse gas emissions. In the general case, the electrical energy consumed in production of the feedstock material for machining may be generated from different sources than that used for production of the additive process feedstock material and, thus, have different carbon emissions per unit of energy produced. Similarly, the energy consumed in the manufacturing facility may be generated differently than that used for feedstock material production. Accounting for the greenhouse gases associated with the production processes must take this into consideration and would require that additional terms be added to the model.

It is recognized that there are many factors in addition to energy consumption that may contribute to selection of manufacturing methods. Factors in selecting a manufacturing approach include part complexity (additive manufacturing may be the preferred option for producing a highly complex part – e.g., with intricate internal passages – even if it is not the fastest or least energy option), material property requirements, time (both lead time and manufacturing time), and material usage. Another attribute of additive manufacturing is that it may produce lighter-weight components which can reduce energy consumption in the use phase of some products. Reducing the weight of components used in transportation systems will reduce fuel consumption during operation. For example, it has been estimated that decreasing the weight of commercial aircraft by selective use of additive manufacturing to produce lighter components could reduce energy consumption during aircraft operation by as much as almost $2800 \text{ E}+15 \text{ J/year}$ and reduce associated CO_2 -equivalent by as much as $215\text{E}+6 \text{ MT/year}$ (Huang et al, 2015). Additional energy savings and emissions reductions could be realized by reducing the weight of ground transportation vehicles. Ultimately, all of these factors boil down to cost; as energy costs continue to climb and incentives are offered to reduce net emissions and energy consumption, the energy expenditure for manufacturing and product operation can become a more significant factor. However, the intention of this model is not to address these other factors, but to offer a tool that can be used to discriminate between manufacturing processes purely from an energy consumption perspective.

Acknowledgement

This work was supported by NASA's Office of Strategic Infrastructure and by the Advanced Materials and Processing Branch at NASA's Langley Research Center. The authors would like to thank the reviewers for their thoughtful comments which helped to enhance the quality of this work.

References

Allwood, J. M., Ashby, M. F., Gutowski, T. G., & Worrell, E. (2011). Material Efficiency: A White Paper. *Resources, Conservation and Recycling*, 55(3), pp. 362-381.

Baumers, M., Tuck, C., Hague, R., Ashcroft, I., & Wildman, R. (2010, August). A Comparative Study of Metallic Additive Manufacturing Power Consumption. In *Solid Freeform Fabrication Symposium Proceeding, The University of Texas at Austin, USA* (pp. 278-288).

Baumers, M., Tuck, C., Wildman, R., Ashcroft, I., & Hague, R. (2011). Energy Inputs to Additive Manufacturing: Does Capacity Utilization Matter? *EOS*, 1000, 270.

Carroll, P. A., Brown, P., Ng, G., Scudamore, R., Pinkerton, A. J., Syed, W. U. H., Sezer, H. K., Li, L., & Allen, J. (2006, May). The Effect of Powder Recycling in Direct Metal Laser Deposition on Powder and Manufactured Part Characteristics. In *Proceedings of AVT-139 Specialists Meeting on Cost Effective Manufacture via Net Shape Processing. Amsterdam, The Netherlands. Brussels, Belgium: NATO Science and Technology Organization*.

Dahmus, J. B., & Gutowski, T. (2004, November). An Environmental Analysis of Machining. In *ASME International Mechanical Engineering Congress and R&D Expo* (pp. 13-19).

Dawes, J., Bowerman, R., & Trepleton, R. (2015). Introduction to the Additive Manufacturing Powder Metallurgy Supply Chain: Exploring the Production and Supply of Metal Powders for AM Processes. *Johnson Matthey Technology Review*, 59(3), pp. 243-256.

Diaz, N., Helu, M., Jarvis, A., Tönissen, S., Dornfeld, D., & Schlosser, R. (2009). Strategies for Minimum Energy Operation for Precision Machining. *Laboratory for Manufacturing and Sustainability*.

EIA (2014). Manufacturing Energy and Carbon Footprint, Sector: Fabricated Metals (NAICS 332) http://energy.gov/sites/prod/files/2014/02/f7/2014_fabricated_metals_energy_carbon_footprint.pdf, accessed June 28, 2015.

Eom, J., Schipper, L., & Thompson, L. (2012). We Keep on Truckin': Trends in Freight Energy Use and Carbon Emissions in 11 IEA Countries. *Energy Policy*, 45, 327-341. doi:10.1016/j.enpol.2012.02.040.

Gutowski, T., Dahmus, J., & Thiriez, A. (2006, May). Electrical Energy Requirements for Manufacturing Processes. In *13th CIRP International Conference on Life Cycle Engineering* (Vol. 31).

Huang, R., et al. (2015). Energy and Emissions Saving Potential of Additive Manufacturing: the Case of Lightweight Aircraft Components. *Journal of Cleaner Production* (2015), <http://dx.doi.org/10.1016/j.jclepro.2015.04.109>.

Kellens, K., Yasa, E., Dewulf, W., & Duflou, J. (2010). Environmental Assessment of Selective Laser Melting and Selective Laser Sintering. *Going Green—CARE INNOVATION 2010: From Legal Compliance to Energy-efficient Products and Services*.

Kesler, S. E. (2007). Mineral Supply and Demand into the 21st Century. In *US Geological Survey Circular 1294: Proceedings for a Workshop on Deposit Modeling, Mineral Resource Assessment, and their Role in Sustainable Development*. Reston, VA: US Geological Survey (pp. 55-62).

Kobryn, P. A., Ontko, N. R., Perkins, L. P., & Tiley, J. S. (2006). *Additive Manufacturing of Aerospace Alloys for Aircraft Structures*. Air Force Research Lab Wright-Patterson AFB OH Materials and Manufacturing Directorate.

Morrow, W. R., Qi, H., Kim, I., Mazumder, J., & Skerlos, S. J. (2007). Environmental Aspects of Laser-Based and Conventional Tool and Die Manufacturing. *Journal of Cleaner Production*, 15(10), pp. 932-943.

Mudd, G. M., & Ward, J. D. (2008, December). Will Sustainability Constraints Cause Peak Minerals. In *3rd International Conference on Sustainability Engineering and Science: Blueprints for Sustainable Infrastructure*. Auckland, New Zealand.

Reeves, P. (2009). Additive Manufacturing—A Supply Chain Wide Response to Economic Uncertainty and Environmental Sustainability. Econolyst Limited, The Silversmiths, Crown Yard, Wirksworth, Derbyshire, DE4 4ET, UK.

Sparks, T., & Liou, F. (2008). Direct-to-Part Machining Waste Recycling using Laser Metal Deposition. In *Proceedings of the Solid Freeform Fabrication Symposium 2008* (pp. 290-296).

Telenko, C., & Seepersad, C. C. (2010). Assessing Energy Requirements and Material Flows of Selective Laser Sintering of Nylon Parts. In *Proceedings of the Solid Freeform Fabrication Symposium 2010* (pp. 8-10).

Yoon, H. S., Lee, J. Y., Kim, H. S., Kim, M. S., Kim, E. S., Shin, Y. J., W.S. Chu & Ahn, S. H. (2014). A Comparison of Energy Consumption in Bulk Forming, Subtractive, and Additive Processes: Review and case study. *International Journal of Precision Engineering and Manufacturing-Green Technology*, 1(3), pp. 261-279.