

TFAWS **Interdisciplinary** Paper Session



A Streamlined Approach to Spatial Mapping of Complex 3D Thermal Boundary Condition Data

Robert F. Hawkins (NASA/MSFC)

TFAWS
LaRC 2019

Thermal & Fluids Analysis Workshop
TFAWS 2019
August 26-30, 2019
NASA Langley Research Center
Hampton, VA



Objective



- The objective of this presentation is to outline the modeling techniques used with the integrated thermal analysis of a terrestrial lunar lander demonstrator. Specifically, the techniques outlined here will focus on spatial mapping of convective and radiative exhaust plume results from a computational fluid dynamics (CFD) analysis. Two cases were investigated:
 - Lunar lander demonstrator firing on-pad (worst case).
 - Lunar lander demonstrator hovering at an elevated position above the launch pad.
- For the purposes of information control, this presentation will focus on the modeling techniques only, using altered/dimensionless data where necessary.

- The lunar lander demonstrator modeled is known as XL-1T (terrestrial), born from a collaborative effort between Masten Space Systems (MSS) and NASA, under NASA's Lunar CATALYST (also known as Lunar Cargo Transportation and Landing by Soft Touchdown) initiative.
- The lander is a reusable vertical takeoff/vertical landing (VTVL) test bed which is controlled by four throttleable main engines utilizing green hypergolic propellants.

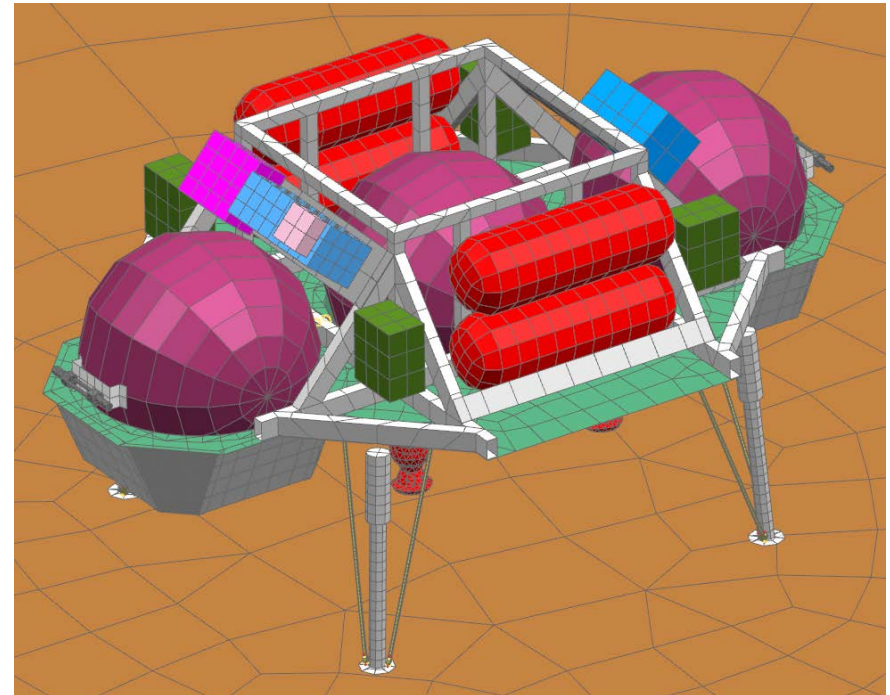
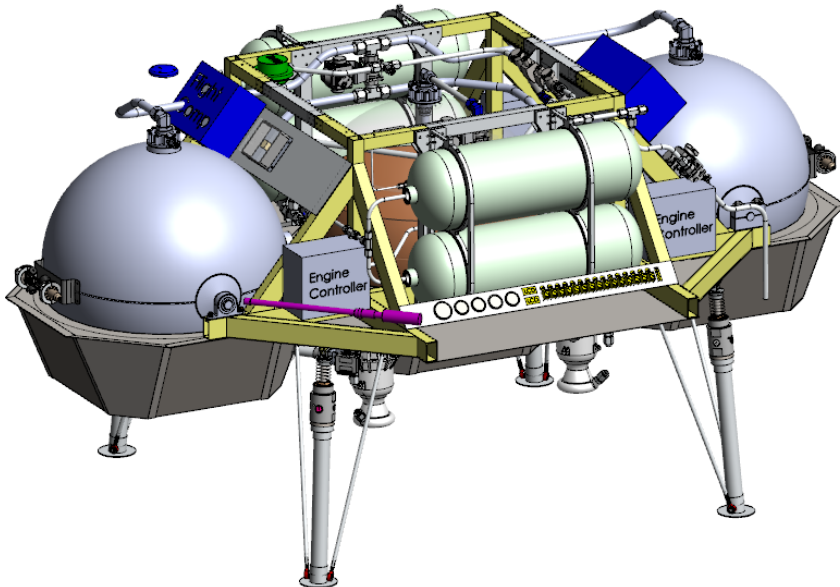

- The positioning of the engines creates a unique environment where base-flow physics creates a fountain plume that impinges directly on the base of the vehicle, greatly increasing convective plume loads.
- The two plume study cases differ in that the fountain plume reacts differently to the nozzle plumes. This difference is primarily attributed to the Coanda effect.
 - On-pad: the fountain plume oscillates between nozzle plumes, moving about the center of the vehicle base.
 - Elevated: the fountain plume attaches to two of the nozzle plumes, reducing base heating.

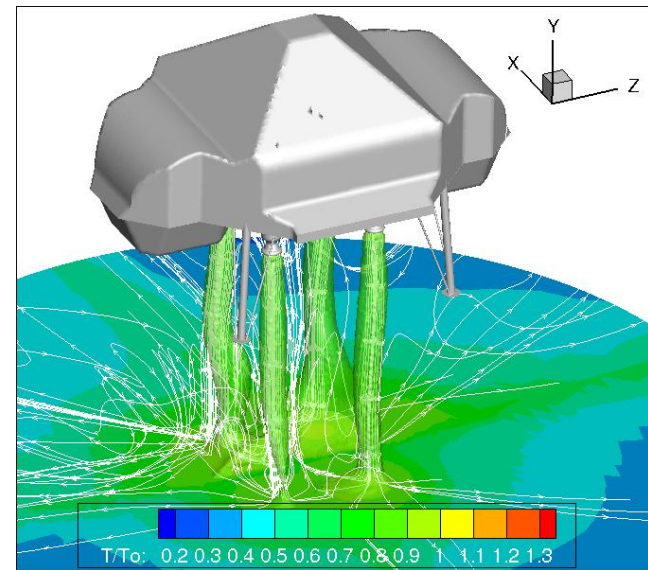
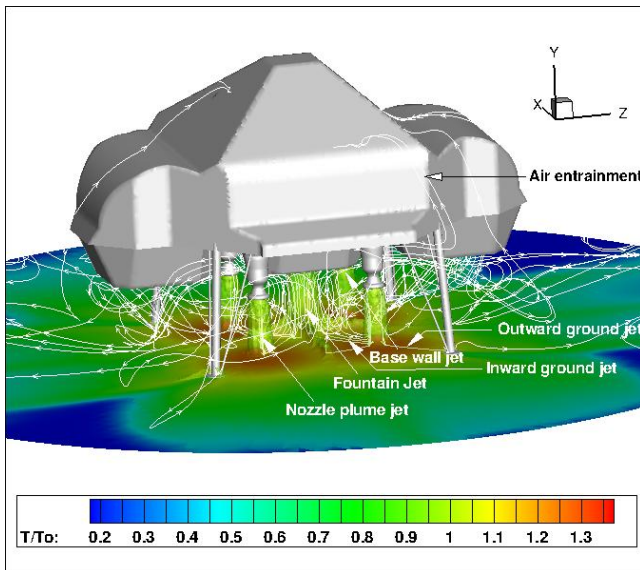



Plume Environment

- The asymmetric geometry of XL-1T combined with the complex plume interactions creates a difficult plume environment to map to the thermal model.
- The Coanda effect is the tendency of a fluid jet to be attracted to an adjacent flat or curved surface. In this instance, the four adjacent nozzle plumes caused the fountain plume to oscillate across the vehicle base in the on-pad case and attach to two of the nozzle plumes during the elevated case. This phenomenon makes mapping plume flux data difficult in a spatial sense due to varying flux values at any given point on the vehicle surface.
- The plume data obtained from the CFD analysis was broken down by body points according to Cartesian coordinates on the vehicle surface. With each point the following data was provided:
 - Pressure (P)
 - Adiabatic Wall Temperature (T_{aw}), or Recovery Temperature (T_{rec})
 - Incident Radiative Plume Flux (q_r)
 - Cold Wall Convective Plume Flux (q_{cw})
 - Ambient Temperature (T_{am}), or Cold Wall Temperature (T_{cw})

Plume Calculation

- Radiative flux values were incident values calculated using estimated optical properties, so the values could be applied directly to the corresponding points. However, convective flux values and accompanying convective heat transfer coefficients change depending on the vehicle temperature, requiring constant recalculation throughout the analysis.
- For these calculations the convective heat transfer formula can be written as the following:
 - $q_c = h_c \cdot (T_{rec} - T_{surface})$, where h_c is the convective heat transfer coefficient and $T_{surface}$ is the temperature of the vehicle surface.
- To account for the changing convective heat transfer, the same equation can be written with respect to the cold wall flux:
 - $q_{cw} = h_c \cdot (T_{rec} - T_{cw})$, where T_{cw} is the ambient temperature of the vehicle.
- Combining the two equations yields a relationship which calculates the convective flux while accounting for the change in the convective coefficient:
 - $\frac{q_c}{q_{cw}} = \frac{T_{rec} - T_{surface}}{T_{rec} - T_{cw}}$, or $q_c = q_{cw} \cdot \frac{T_{rec} - T_{surface}}{T_{rec} - T_{cw}}$

- A select group of components were chosen for the focus area of plume application in the thermal model. These components were the highest risk areas and the ultimate goal of the analysis is to provide design inputs and recommendations for plume shielding and general thermal protection for the vehicle.

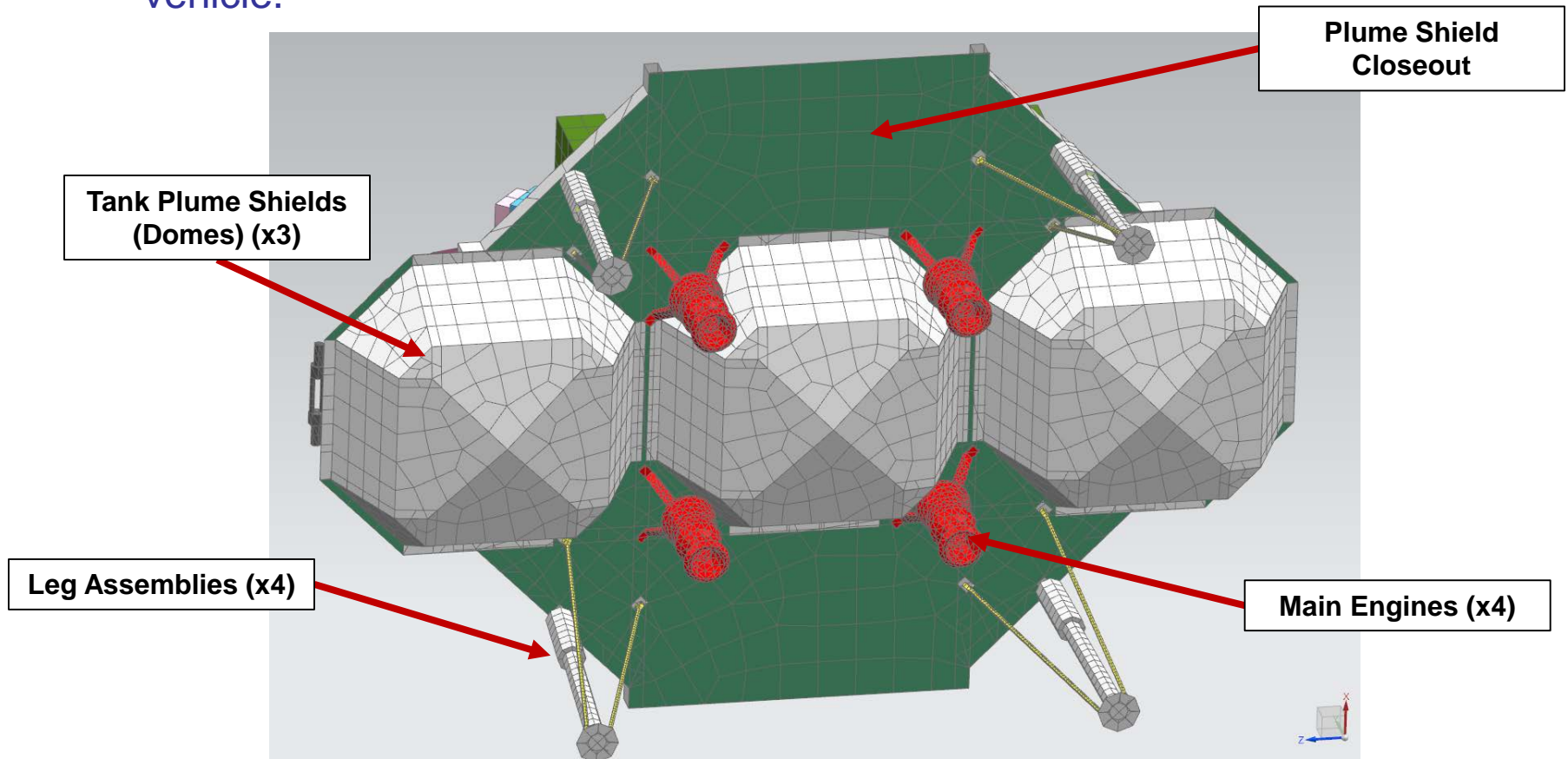

Plume Application

- Thermal modeling was performed using Siemens Simcenter3D(SC).
- The fields capability of SC allowed direct inputs of the .csv raw data from the CFD analysis via embedded Excel files. These were separate Cartesian based fields with dependent variables representing q_{CW} , q_r and T_{rec} . Furthermore, these fields were delimited by associated component geometry of the vehicle (e.g. q_{CW} linked to plume shielding, q_{CW} linked to legs, etc.).

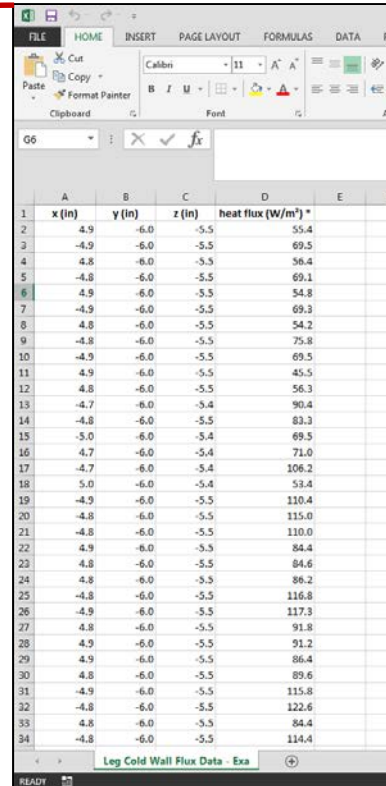
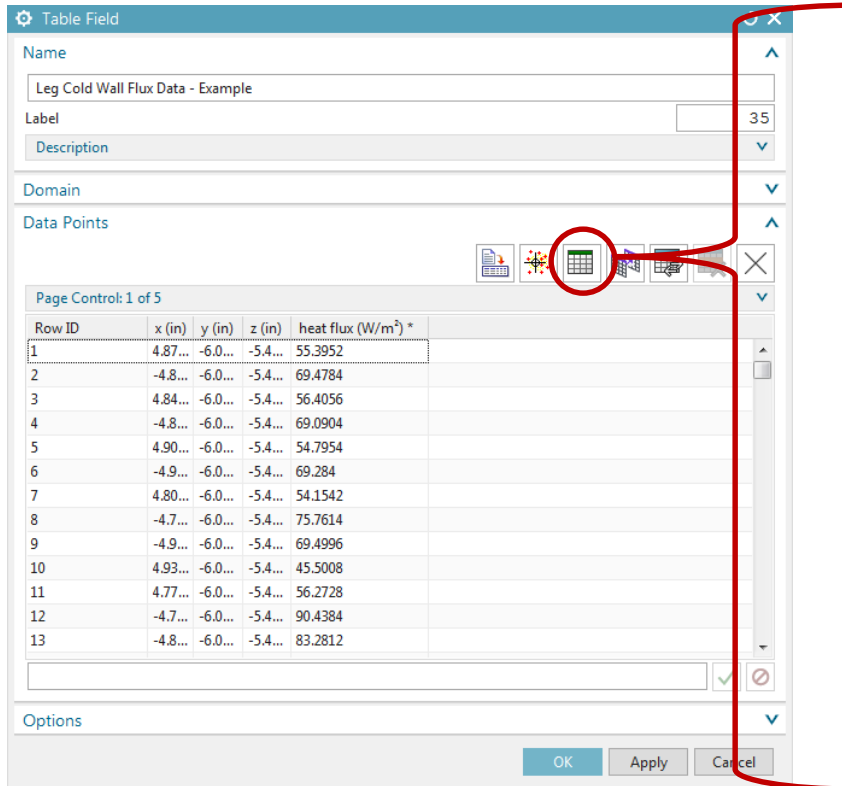

and

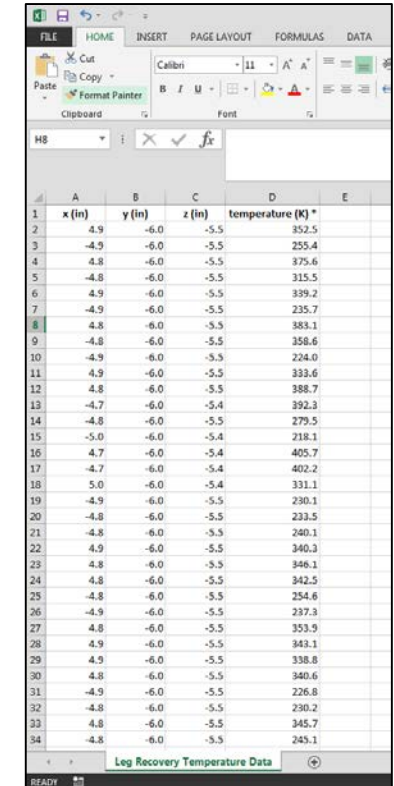

- With the data represented in appropriate fields, loads can be created and mapped to applicable geometry.
- To utilize the preceding equations to recalculate convective flux values as the vehicle temperatures change, conditional statements can be used in the value field directly.

Select Target Geometry

Use If/Then Statement to control length of fire time.
*If(time < 'fire time'[sec])
 Then('calculation')
 Else(0)*

Direct values accompanied with [unit], and 'temperature' recalls the surface temperature from the model.

Type equation directly into value field.

Use fd("field name") to recall appropriate fields for equation. Units carried over from field input.

Extended Text Entry

```

f(x)
If(time<6[sec])
Then(
((fd("Leg Recvr T")-temperature)/(fd("Leg Recvr T")-300[K]))*(fd("Leg Cold Wall Flux Values"))
)
Else(0)
    
```

$$q_c = q_{cw} \cdot \frac{T_{rec} - T_{surface}}{T_{rec} - T_{cw}}$$

- The radiative plume loading is more straight forward, requiring only to recall the field data stored for each set of geometry, along with time controls.

Select Target Geometry

Use If/Then Statement to control length of fire time.

$$\text{If}(\text{time} < \text{'fire time' [sec]})$$

$$\text{Then}(\text{'calculation'})$$

$$\text{Else}(0)$$

Direct values accompanied with [unit], and 'temperature' recalls the surface temperature from the model.

Type equation directly into value field.

Use fd("field name") to recall appropriate field for values. Units carried over from field input.

Extended Text Entry

```

f(x)
If(time<6[sec])
Then(
fd("LegsRadPlumeFlux")
)
Else(0)
    
```

Thermal Loads

Type: Heat Flux

Name: Leg Radiative Flux - Example

Description

Destination Folder

Region

Group Reference

Select Object (4068)

Element Selection Filtering

Filter Type: OD Elements

Excluded

Magnitude

Heat Flux: $\text{If}(\text{time} < 6[\text{sec}]) \text{Then}(t \text{ Btu}/(\text{s}\cdot\text{ft}^2))$

Reference Temperature Set

Heater Control

Multi-Layer Shells

Card Name: Heat Flux

OK Cancel

- To check the mapping and convective calculations, the plume loads can be plotted via contour plots. This feature provides options to manually input surface temperatures for the calculations, or animating across a span of surface temperatures.

Screenshot 1: Solution Boundary Conditions

Name	Property
DomeConvFluxFormula	Heat Flux
BaseConvFluxFormula	Heat Flux
LegsConvFluxFormula	
EnginesConvFluxFormula	
DomeRadFlux	
LegsRadFlux	
BaseRadFlux	
EnginesRadFlux	
Convection to Environment(2)	

Screenshot 2: Plot Options

Overlap Options: Add
Value: 0.0
Plot Type: Static Plot

Evaluation Points

Property	Value	Unit
Temperature	0	K
Time	0	s

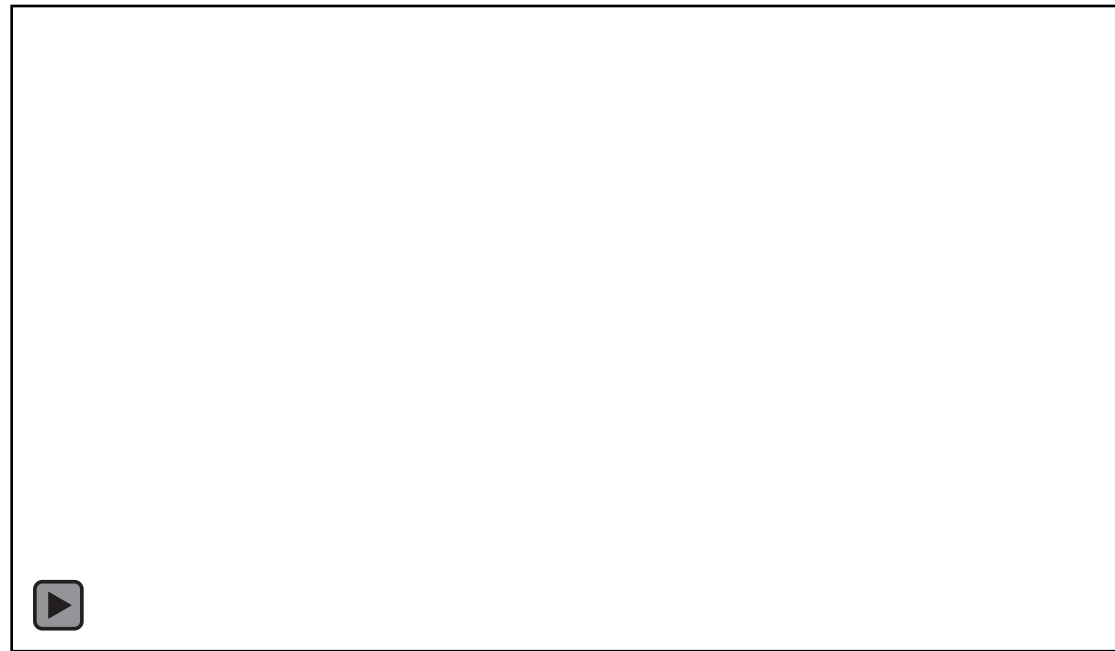

- Due to the density of the received plume data, a Nearest Neighbor interpolation scheme was chosen from the available options to apply the mapping without sacrificing fidelity.

- Plume loads mapped closely relative to CFD results and integrated thermal analysis results tracked as expected.
- The application of plume loads sped significantly by utilizing .csv raw data without data manipulation or external script routines.
- Running plume cases with plume loading can result in extended solve times.

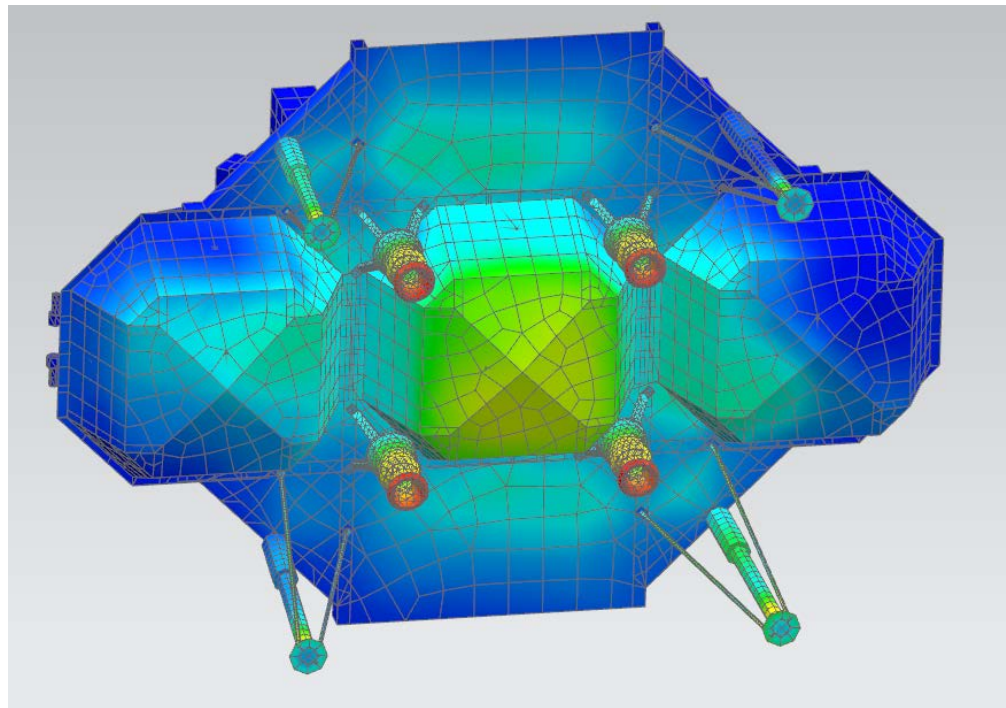
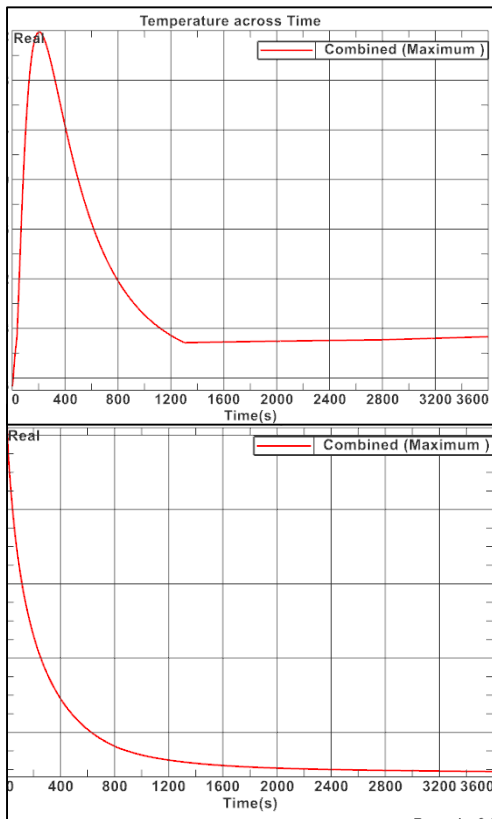



Acknowledgements



- Carl J. Poplawsky (MAYA Heat Transfer Technologies)
- Jean-Frederic Ruel (MAYA Heat Transfer Technologies)
- Ten-See Wang (NASA/MSFC)
- Kyle Knox (NASA/MSFC)
- Matt Bergman (Masten Space Systems)
- Dan Popok (Jacobs ESSSA/MSFC)



References

- T.S. Wang, F. Canabal, K.S. Knox, R.F. Hawkins (NASA/MSFC), and M. Bergman (MSS). “Analysis of Base-Heating Environment During Ground Testing of a Lunar Lander Demonstrator”. JANNAF 2019