



Idioms

Categorization, lexical representation and the question of compositionality

Therese Vegge

Supervisor

Professor Dagmar Haumann

This Master's Thesis is carried out as a part of the education at the University of Agder and is therefore approved as a part of this education. However, this does not imply that the University answers for the methods that are used or the conclusions that are drawn.

University of Agder, 2012

Faculty of Humanities and Education

Department of Foreign Languages and Translation

Acknowledgments

I wish to express my gratitude to my family and friends for their support and encouragement during my years as a student. Special thanks to my teacher and supervisor, Professor Dagmar Haumann, for her valuable guidance and exhaustive comments. Our many inspiring meetings contributed greatly to my motivation and enabled me to complete this thesis.

Contents

1. Introduction	1
2. Idioms as a concept and category	4
2.1. The concept	4
2.2 Categorizing idioms	6
2.3 The idiom category.....	10
3. Lexical representation.....	14
3.1 Chomsky and the lexicon	15
3.2 Representational Modularity	17
3.3 Lexical licensing of idioms	20
4. The flexibility of verb phrase idioms	25
4.1 Modification and quantification	25
4.2 Transformations	28
4.2.1 Passivization.....	29
4.2.2 Topicalization.....	32
4.2.3 Subject control.....	33
4.3 Lexical substitution	34
5. Testing the flexibility of verb phrase idioms.....	38
5.1 Method	38
5.1.1 The test subjects	38
5.1.2 The materials	38
5.1.3 Procedure.....	39
5.2 Results	40
5.2.1 The overall results	40
5.2.2 The groups.....	41
5.2.3 Types of constructions	42
5.2.3.1 Modification and quantification	42

5.2.3.2 Passivization.....	47
5.2.3.3 Lexical substitution	53
5.3 Concluding remarks	56
6. Conclusion.....	60
Bibliography	63
Appendix 1	68

1. Introduction

Expressions such as *kick the bucket* and *bury the hatchet* are frequently used and widely familiar among speakers of English. Expressions of this type make up the linguistic category ‘idioms’. They are used as common parts of language, but differ from regular expressions in being peculiar and having interpretations that extend their literal readings. Theoretical linguistics is concerned with investigating the correspondence between form and meaning in language. Generative grammar explains that linguistic expressions are generated and defined by a number of syntactic and semantic rules. Idioms, however, are notorious for breaking these rules. The phenomenon is still firmly integrated in language and well-known as a can of worms in linguistic theory. In this thesis I will open up this can by drawing attention to conceptual structures as well as the syntax and semantics of idioms. The thesis concerns the flexibility idioms and the question to investigate is if this flexibility implies internal semantic structures.

To discuss this, the thesis is structured as follows: Chapter 2 aims at describing the complexity of the concept ‘idiom’ and at explaining why we recognize these variant expressions as belonging to the same category. When dealing with idioms it is useful to discuss what they really are. Attempting to define and set boundaries for the category can prove problematic as the members vary both in features and behavior. The intention of this chapter is not to demarcate the category or to provide a typology of idioms, but rather to give an impression of the concept.

The difficulty in finding a single and uniform definition for ‘idiom’ is related to the variant syntactic and semantic behavior of idioms. In light of these difficulties, the reason why we still consider them as making up one category is inconspicuous. To understand this, it can be useful to discuss the function and structure of a category. In this respect, I will explore categorization with focus on Prototype Theory. I find this approach useful for understanding the function of language and idioms. Language is not only a set of syntactic and semantic rules it is also a reflection of how the human mind perceives the world. People categorize in order to make sense of concepts. In order to translate these mental images into language, there must be a correlation between phonology, syntax, semantics and also conceptual structures.

In the context of syntax and semantics, the representation of idioms as lexical items in a generative framework is a controversial issue. Chapter 3 is concerned with the structural

analysis of idioms. The main focus in this chapter is on Jackendoff's (1997) lexical licensing approach, according to which the syntax of idioms is governed by the semantic and conceptual properties of lexical items. It is shown that the difficulties linguists encounter with respect to the lexical representation of the flexible structures of idioms are taken into account in this approach. As will be shown in this chapter, many idioms can be modified and transformed in various ways while still retaining their idiomatic interpretation.

Idioms are generally considered not to follow the principle of compositionality which states that "[...] the meaning of a complex expression is a function of the meaning of its constituent parts and the way these are syntactically combined." (van der Linden, 1993: 2). Several linguists follow the claim that idioms are noncompositional. However, in this thesis I will point to aspects of idioms that demonstrate compositionality. In Chapter 4 I discuss how syntactic flexibility supports the assumption that many idioms have an internal semantic structure. This counters the claim that idioms are expressions for which the whole meaning is not deducible from its constituent parts. Modification and quantification have often been applied as touchstones in the discussion of the structure of idioms. Though there is little dispute that it is possible to modify many idioms, some linguists claim that modification is only syntactic because idioms do not have constituents that carry meaning. I will address this issue by discussing operations such as modification, quantification, passivization, topicalization, subject control and lexical substitution. It is difficult to make claims about these kinds of alterations because interpretation of an idiom is dependent on the hearer, especially in cases where the idiomatic structure has a possible or competing literal interpretation. However, expressions that have two possible readings are often recognized as idiomatic. It has been argued that the structure of familiar idioms can be transformed without the idiom losing idiomatic meaning. Chapter 5 reports on a pilot study on idiomatic structures whose main aim was to put the theoretical claims and predictions concerning compositional idioms to the test.

The purpose of this thesis is to explore the idiom phenomenon. I will provide an account of the variant behaviors of idioms and the theoretical problems that follow. These behaviors complicate definition, categorization and lexical representation. There is also controversy in the discussion on idioms in different sentence constructions. Idioms are mainly thought of as fixed in composition, i.e. that they are noncompositional. However, others seem to behave relatively similar to literal expressions. I argue that certain idioms have a syntactic and semantic structure that is not as fixed and opaque as generally considered. If this is the case, these idioms can then be described as compositional. In order to discuss this I will give

attention to different views proposed by linguists. The question of compositionality is an important matter in idiom research and it has consequences for how to account for them in linguistic theory. It follows then that this thesis emphasizes theoretical deliberations. However, these considerations are also accompanied by a minor pilot study testing some of the assumptions discussed in the thesis. This study explores the affect various syntactic operations have on the interpretation of idioms.

2. Idioms as a concept and category

In this chapter I will give attention to the difficulty in defining idioms. In light of this difficulty, I will provide a different approach and try to explain them in terms of theories of categorization. Assumptions and observations discussed in this account relates to the theoretical material applied in the remainder of the thesis.

2.1. The concept

As a phenomenon idioms are controversial and difficult to account for. Serious discussions on idioms in western linguistics started in the 1950s. The difficulty of defining ‘idiom’ might be a reason as to why this is such a recent field of study. Constructing a theory of idioms presents a challenge (Strässler, 1982: 26). In his article “Studies in Irreversible Binominals” (1959) Malkiel writes

“[...] one does well to steer clear of any reference to the ill-defined category of ‘idioms’ or phraseological formulas. These have been variously spoken of as sequences yielding imperfectly to routine grammatical analysis, as passages strikingly rebellious to literal translation [...], as semi-autonomous pieces of congealed syntax [...], as word-groups whose aggregate meaning cannot be fully predicted even from thorough knowledge of each ingredient (a semantic approach), and, in stylistic or esthetic terms, as clichés, i.e., as combinations once suffused with fresh metaphoric vigor, but gradually worn thin by dint of use.” (Malkiel, 1959: 115)

This is an uncontroversial view. A property that seems to have gained most attention is that idioms are noncompositional which means that they are expressions whose meaning cannot be deduced from its constituent parts. Among the linguists who follow this claim are Sweet (1899), Hockett (1958), Katz and Postal (1963), Healey (1968) Chafe (1968), Weinreich (1969), Fraser (1970), Makkai (1972), and Chomsky (1980). Though this claim may be appropriate with respect to some idioms, it does not convey all the properties and peculiarities idioms involve.

Charles Hockett was the first western linguist to deal with idioms. Under his account he explains that the idiomatic status of a form depends on its function in relation to other forms it co-occurs with. From this it follows that idioms are not particular forms, but rather functions or particular occurrences of forms, e.g. “[...] *new* is an idiom in *She wants a new*

hat, but not in *I'm going to New York*, because here it is part of the larger idiom *New York* [...]” (Hockett, 1958: 172). Thus, any linguistic form from a morpheme to a larger sentence construction can constitute an idiom. Hockett also asserts that an idiom can only be understood if its meaning is learned as additional information to language, i.e. conventionality (Hockett, 1958: 172). The latter statement is still credited today but more recent definitions of idioms cover a smaller range of expressions than Hockett describes.

Andreas Langlotz discusses in his book *Idiomatic Creativity* (2006) the core properties of idioms, such as conventionalization, compositeness and (non)compositionality (Langlotz, 2006: 3f). These are properties that will be discussed throughout this thesis. Though Langlotz assigns noncompositionality as a basic property of idioms, he is also concerned with including other linguistic aspects in idiom interpretation: “[...] idiomatic constructions can be described as complex symbols with specific formal, semantic, pragmatic and sociolinguistic characteristics.” (Langlotz, 2006: 3). He also explains that a phrase can only be defined as idiomatic by exploring its “degree of idiomaticity, i.e. its degree of belonging to the class of idiomatic constructions.” (Langlotz, 2006: 5). Since idioms change appearance from one instance to another, they must be analyzed accordingly. Consequently, there can not be one single definition that would cater for all idioms.

A similar view is defended by Nunberg et al. (1994). They argue that “[...] idioms occupy a region in a multidimensional lexical space, characterized by a number of distinct properties: semantic, syntactic, poetical, discursive and rhetorical.” (Nunberg et al., 1994: 492). They also assert that idioms display a great number of properties, but not every single idiom displays every property. Idioms may show degrees of inflexibility, some type of figuration, they are proverbial, often used in informal situations and they are used to express evaluation of situations. What sets these linguists aside is their claim that the feature of noncompositionality in idioms is inconclusive. The authors subdivide idioms into two types: those whose meaning cannot be predicted on the basis of their constituent parts and those whose meaning can be predicted from their constituents. In this thesis I follow Nunberg et al. in assuming that idioms are either noncompositional (*saw logs*) or compositional (*spill the beans*) idioms. The question of compositionality is an important and widely discussed matter in idiom research and it has consequences for their lexical representation which will be discussed later in this thesis.

Even though idioms are treated as a category, the defining features of this category are neither apparent nor conclusive. Thus, van der Linden asks the question of whether idioms should “be defined as a class of expressions, or should idiomaticity be defined as a property

of expressions. [...] *idiomaticity*, the semantic property that the meaning of an idiom is exclusively a property of that expression.” (van der Linden, 1993: 13, 9). Van der Linden rejects the division between noncompositional and compositional idioms and rather claims that expressions can be partly compositional. He maintains that idioms do not form a category of elements with consistent features and that they should be defined according to degree of idiomaticity. Degree of idiomaticity can be attributed to constituent parts of the idiom, but is defined according to the whole idiom.

I agree that idioms as a whole hold an exclusive meaning. However, due to conventionality, compositionality and idiomaticity I contend that, in many cases, the meaning of an idiom can be understood from meaning of the constituent parts. Also, my understanding of idiomaticity is that an expression “has ‘proper idiomaticity’ if it is judged intuitively by native speakers as usual, natural, and commonly acceptable. In this respect one of fairly acceptable, and concise, definitions of ‘idiomaticity’ will be one that takes it as a function of familiarity and frequency of use.” (Kavka/Zybert, 2004: 55). Thus, I will suggest that there are conventional expressions that can be distinguished as noncompositional and compositional types and these hold different degrees of idiomaticity (cf. chapter 5).

Still, the question remains of why certain expressions are categorized as idioms. The answer to this question involves the exploration of the relation between language and the human mind. Cognitive linguistics investigates this relation by interpreting language as a representation of concepts. This investigation involves exploring hypotheses about reason, implications of human experience for language and also conceptual systems. One way to understand the relation between language and human cognition is to understand the way in which people categorize objects and events in the world.

According to traditional categorization, also known as the classical view, categories are transcendental and they shape the world. An alternative view presents categories as rooted in people’s experience, whence the world shapes categories. I take the latter claim to be best suited to explain the ‘idiom’ category, and it is therefore useful to elaborate on the question of categorization.

2.2 Categorizing idioms

In cognitive linguistics the traditional view of categorization as often been referred to as the classical view because it goes back to Ancient Greece and for a long time it was a philosophical position that influenced psychology, philosophy and linguistics (Taylor, 1995:

22). In a classical view, categories are disembodied and not connected to human experience. Accordingly, categories are notably distinct from each other and thus all members of the same category should have equal properties. Implications of this theory that are often discussed in cognitive linguistics derive from the ideas of Aristotle. He maintained that categorization involved differentiating between the essence of and the accidents of things. The essence of an entity is what defines it, e.g. the essence of MAN is that it is animal and two-footed. Other factors such as skin color or culture are accidents and thus irrelevant in assigning the entity to the category MAN (Taylor, 1995: 22).

“To say that an X is a Y, is to assign an entity X to the category Y. We do this by checking off the properties of X against the features which define the essence of the category Y; our knowledge of this set of features characterizes our knowledge of the meaning of the word Y. [...] Aristotle singled out two defining features of the category MAN (and hence two features in the definition of the word man), namely [TWO-FOOTED] and [ANIMAL]. These two features are, individually, necessary for the definition of the category (the destruction of either causes ‘the destruction of the whole’); if any of the defining features is not exhibited by the entity, then the entity is not a member of the category.” (Taylor, 1995: 23).

The classical view then obligates all members of the same category to share the same properties. As there is no graded membership, the boundaries between categories are clear-cut and strict. Already this complicates categorization for idioms as they have no clear essential features. In some versions of this classical view it is postulated that the way we use reason to construct meanings is independent of physical objects and human experience (Lakoff, 1987: 8f).

A different vantage point was offered by the study of cognitive sciences. Cognitive science involves a number of scientific disciplines such as psychology, sociology, philosophy and linguistics. In this thesis I focus on the study of cognitive linguistics. Cognitive linguistics affirms the reliance on cognitive processes and human behavior for the use and development of language. In this sense, categorization is a way to understand human reasoning. Theories of categorization that represent these different views have been developed and are widely discussed in the linguistic world. The new view takes an alternative position and claims that reason and meaning are dependent on people’s cognition (Lakoff, 1987: 9). In other words, “[...] language is not an autonomous cognitive faculty, grammar is conceptualization and knowledge of language emerges from language use.” (Croft/Cruse, 2004: 1f).

Wittgenstein (1967) recognized many shortcomings of classical theory. He pointed out that boundaries of categories were not as clear as classical theory had maintained (Lakoff, 1987: 26). On the basis of the example category GAME, he showed that categories display fuzzy boundaries. There are features that are associated with the category, e.g. competition, amusement, winning or losing. However, these are not essential features that define the category. Wittgenstein claimed that categories do not have a set of shared properties, but are built on the basis of similarities and relationships. What makes GAME a category then, is the notion of *family resemblance* (Wittgenstein, 1967: 31f). Members of categories need not share categorical features in the sense that they are absolute members, rather they display resembling features. An implication of this is that categories have extendable boundaries and allow for new entries (Lakoff, 1987: 18). An example of this is the category NUMBER. Originally this category consisted of integers only, however it continuously expanded with the inclusion of rational numbers, complex numbers and transfinite numbers (Lakoff, 1987: 16). Wittgenstein's observations had consequences for the overall perception of categorization.

Another theory of categorization was constructed along these lines (Lakoff, 1987: 39). Eleanor Rosch is known for her work that produced *Prototype Theory* (PT). This theory relies on physical and social experience in the process of categorization, and this refutes the classical theory which suggests categories are independent of bodily experience. Through experiments on primary categories of color and various physical objects Rosch discovered that categories in fact have members with variant properties and also members that are considered better examples than others (Taylor, 1995: 43f). Her findings challenge the classical theory. With her work, Rosch laid the groundwork for PT.

According to Rosch, there are two principles that govern the formation of categories. The first principle is called *cognitive economy* and refers to the fact that humans categorize in order to preserve information and make sense of the world. Organizing elements into fewer categories with fewer properties reduce differences and creates manageable cognitive structures of information. The second principle concerns the *perceived world structure* that elements seem to have. The world is structured as a result of correlations made by humans according to the features that objects carry, e.g. wings and feathers are more likely to occur on the same entity than wings and fur (Margolis/Laurence, 1999: 190f). To illustrate the organization of categories and membership, Rosch explains categorization in terms of their horizontal and vertical features as illustrated in the hierarchical system in (1):

(1)

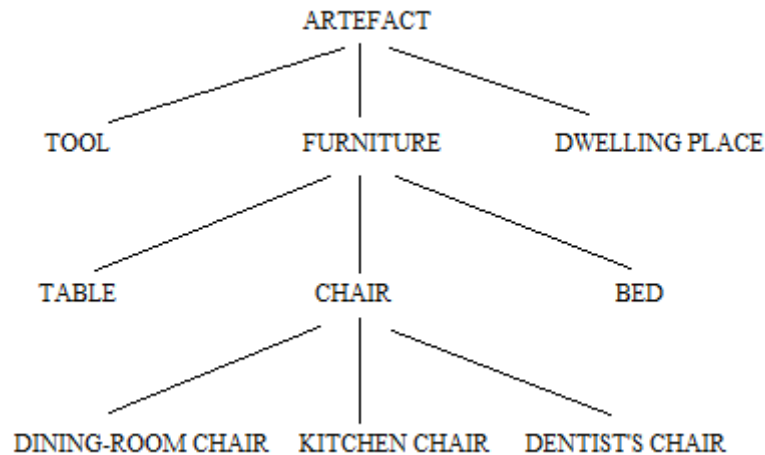

(Taylor, 1995: 47)

Categories are distinguished horizontally according to their different features, e.g. TOOL or FURNITURE. The vertical aspect represents different levels of inclusiveness in these categories e.g. ARTEFACT; FURNITURE; CHAIR; KITCHEN CHAIR as illustrated in the figure (1). The higher the level is on the scale, the more members the category includes, e.g. TOOL would include HAMMER, SCISSORS etc. The lower in level, the more specific in features the category is, e.g. HAMMER; ‘ball-peen hammer’, ‘sledgehammer’.

Prototypes are the best representatives of their category, e.g. in the category BIRD, a ‘robin’ is considered a prototype because it is more representative of the category as opposed to ‘penguin’ which is at the periphery. The different features of objects demonstrate that PT also accounts for asymmetries that can be found among the members of a category. This is referred to as *prototype effects* (Lakoff, 1987: 40f). Therefore, the taxonomic system in (1) is a good way to represent the relationship between objects.

Such a system conflicts with an idea of a world of categories with only clear-cut boundaries. A taxonomic structure consists of categories of objects that relate to each other by level of inclusion. This inclusion depends on category properties. A hierarchical structure is one where all categories are embedded within another except for the one on the highest level (Margolis/Laurence, 1999: 191f). There are three different levels of information about an object; the superordinate, the basic and the subordinate level. The superordinate information about e.g. a ‘chair’ is FURNITURE and ‘kitchen chair’ is defined as subordinate information (Lakoff, 1987: 46). The *basic-level categories*, e.g. CHAIR, are most important for Rosch’s

assumptions about categorization. The reason for this is that the basic level is where most knowledge about objects and concepts is organized. This knowledge centers on

“Perception: Overall shape: single mental image; fast identification.
Function: general motor program.
Communication: Shortest, most commonly used and contextually neutral words, first learned by children and first entered into the lexicon.
Knowledge: Organization: Most attributes of category members are stored at this level.” (Lakoff, 1987: 47).

Tversky and Hemenway (1984) maintain that people associate objects and events as part-whole structures. The parts of an object are related to the function and shape etc. as a whole and this organization occurs at basic level (Tversky/Hemenway, 1984: 182f). Similarly Lakoff and Johnson (1980) suggest that metaphorically abstract entities in the world are structured in much the same way as our knowledge of physical objects. Most people will thus recognize the properties at basic level as parts of the entity in question. These parts determine the function and shape of the whole entity that they constitute (Lakoff, 1987: 47).

This idea of categorization then also applies to categories of language, e.g. idioms. With this in mind, it is possible to imagine idioms as a category based on the assumption that categories are cognitive representations of how we perceive the world, in this case how use of language is perceived. PT provides a framework for the organization of meaning in terms of cognition. The principles of PT may be used as guidelines for understanding how human reasoning works when generating a category for idioms.

2.3 The idiom category

As we have seen, idioms are difficult to define as a category. Nonetheless, the existence of such a category is uncontroversial. From the classical theory point of view, it certainly is difficult to justify that idioms should constitute a category. Prototype Theory, however, provides a more suitable framework.

“First, if categories are defined only by properties that all members share, then no member should be better examples of the category than any other members. Second, if categories are defined only by properties inherent in the members, then categories should be independent of the peculiarities of any beings doing the categorizing: that is, they should not involve such matters as human neurophysiology, human body movement, and specific human capacities to

perceive, to form mental images, to learn and remember, to organize the things learned, and to communicate efficiently.” (Lakoff, 1987: 7).

Following a classical approach then, idioms do not constitute a category as they do not all share the same properties and human experience is certainly an interfering factor. In order to show this, it is necessary to establish some basic assumptions about the category.

It is possible to claim that the properties all idioms share are that they are multiword expressions and their meaning established in convention (cf. chapter 2.1). The former property cannot stand alone, because that would mean having to include all multi-word expressions in the category. One could argue that a shared property is that all idioms are conventional. Although this may be true, it does not hold in light of classical theory where categories must be independent of human experience. Convention is a property that contradicts the laws of classical theory. Convention, by definition, is a cultural phenomenon. If something is conventional, it is learned from human experience of culture and society. Thus, the first implication cannot be accurate in conjunction with the second. Conclusively, idioms cannot form a category under the classical view.

PT, on the other hand, provides a better explanation. PT implicates that not all members need to display all similar qualities. I refer to the features provided by Nunberg et al. (1994) to demonstrate the adequacy of PT. The features under consideration help assign idiomatic membership. In addition to conventionality, idioms are generally considered to display one or more of the following properties: inflexibility in syntax, figuration, proverbiality, affect and informality (Nunberg et al. 1994: 492f). The fact that not all members display all features indicates blurry category membership. However, an idiom that seems to be *prototypical* of its category is *kick the bucket*. It is a multiword expression used frequently both in written and spoken discourse, whence its meaning is familiar to most English speakers. In this sense it is conventional. Though perhaps not widely known, the expression conveys figuration in terms of its historical roots. Allegedly *kick the bucket* refers to how a person would kick the bucket used to stand on when committing suicide by hanging or the use of a bucket after slaughtering a pig (Ammer, 1997: 359). The expression demonstrates syntactic inflexibility (**The bucket was kicked by John*) and it is proverbial in terms of the scenario it describes. The idiom is most often used in informal discourse and it also conveys a form of evaluation of the way in which someone dies. Most people would agree that *kick the bucket* denotes a person dying of natural causes, rather than anything else (despite its alleged origin). Based on these characteristics, one could argue that *kick the bucket*

is a prototypical member of the idiom category. If this is true then this example can serve as a standard of comparison with respect to category membership.

Properties need not be identical or evenly distributed among members of a given category, but the category members must show family resemblance (Wittgenstein, 1967: 32). The expression *keep tabs on*, for example, is also conventional and familiar. However, as opposed to *kick the bucket*, this idiom is also syntactically flexible as it retains its idiomatic meaning in transformations (*Tabs were kept on her*) and modification (*They kept close tabs on John*). It is not figurative or evaluative, but it does denote a type of social behavior. These examples demonstrate that a theory of categorization must account for graded membership, as is the case in PT.

Prototype effects might also help explain the connections between various idioms. The vertical referent, as previously mentioned, is of significance for the categorization of idioms. It denotes the different levels of membership or inclusiveness. This means that objects and events embody different properties that determine their inclusion in categories.

A simple account of idioms could be given in a taxonomic system. Idioms would then be figures of speech at the superordinate level and further specified as idioms at the basic level with the basic knowledge of them as conventional multiword expressions. This conceptual level would then also contain information about idiomatic features (e.g. those proposed by Nunberg et al. 1994), similar to the information about e.g. a chair: inanimate, used for sitting, it has legs, etc. Some of these features need not be inherent or identical in each case, e.g. a chair without legs would still be considered a chair. It is rather function and shape of the item that is of significance. A suggestion for a taxonomic system for the idiom category is given in (2).

(2)

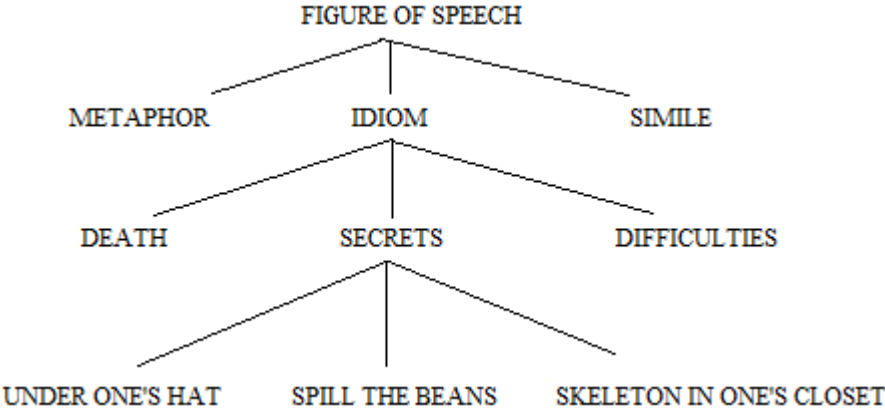

An important process in the categorization of idioms is thus to decide whether or not the parts of a unit sufficiently fulfill some criteria that allow it to be part of this particular category. In (2) the idiomatic phrases *under one's hat*, *spill the beans* and *skeleton in one's closet* have different structures, but they serve the same function of describing situations concerning secrets. The expressions *kick the bucket*, *keep tabs on*, *dog eat dog* and *six feet under* are also members of the idiom category because they as well have the shape of conventional units, which separates this category from METAPHOR and SIMILE. Also, their function is to provide information about social situations.

In this chapter I have briefly summarized two opposing views of categorization and applied them to idioms with the aim to better understand in what sense they constitute a category which contributes to the definition of 'idiom'. Understanding 'idiom', in this sense, is of significance to the theoretical framework of my thesis as this account also demonstrates the significance of conceptual structures in relation to idioms which will be referred to repeatedly throughout this thesis. These structures contribute to the understanding and interpretation of idioms. The next chapter focuses on the role of conceptual structures in lexical representation.

3. Lexical representation

The previous chapter dealt with how we make sense of objects and events in the world. Through categorization we make sense of the things around us and store information. Language is a product of human cognition as it represents the concepts people have about objects and events in the world. The mental image we have of concepts is somehow related to the phonological, syntactic and semantic features of our language. The way in which these relations operate and how to present them in formal syntactic structures is a matter of discussion in the linguistic world. In *Aspects of the Theory of Syntax* Chomsky (1965: 84) proposed the idea of a *lexicon* that should contain all linguistic elements each with its specified phonology, syntactic and semantic features. The unitary representation of these features of an element in the lexicon was labeled a *lexical entry*. Though Chomsky's theory is still credited today, it is not without shortcomings. In this chapter I will explore two theories of lexical representation and present the problems that idioms bring to this context. In addition to exploring Chomsky's proposal, I will draw attention to Jackendoff and his suggestion for lexical representation.

Words, in the traditional sense, pose no problems for representation in the lexicon. A word such as *cat* for instance, has distinct phonological, syntactic and semantic features. The lexical entry for *cat* is given in (3) which represents the phonology (*/kæt/*) syntactic category (+N) and semantic features (+Animate) of the word (Chomsky, 1965: 85). Chomsky states that “[...] the syntactic component of a grammar must specify, for each sentence, a *deep structure* that determines its semantic interpretation and a *surface structure* that determines its phonetic interpretation.” (Chomsky, 1965: 16). In *lexical insertion* items are inserted into deep structure which can be seen as an abstract notion that represents the underlying meaning of the element. This operation makes it possible to represent entries formally in syntactic trees. According to Chomsky (1965), the entries have certain sets of transformations that make it possible to place them in phrase-markers. *Lexical insertion* replaces the information in an entry with a specified categorical feature (Freidin, 1992: 29). In (3) *cat* will then be replaced with the terminal node (N) in a phrase-marker and result in the formal structure represented in (4). Single words are easily handled by this operation because they are dominated by one syntactic category.

(3)

cat /kæt/ [+N, +Count, +Common, +Animate]

(4)

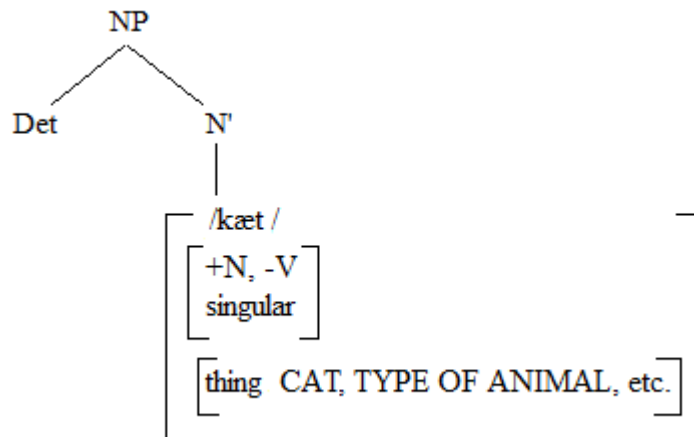

(Jackendoff, 1997: 84)

3.1 Chomsky and the lexicon

While lexical insertion operates in a straightforward manner with words, multiword expressions pose a problem since they defy the requirement that a given element is necessarily dominated by one syntactic category and has no internal structure (X^0). Lexical insertion does not take into account the fact that conceptually we recognize many multiword instances as units, because the words have an idiosyncratic meaning in the presence of each other, e.g. *washing + machine* → *washing machine* (Onysko/Michel, 2010: 1).

The discussion on the definition of word is relevant in this context. The introduction of cognitive linguistics has influenced the need to re-evaluate the traditional conception of the word as “a minimum free form.” (Bloomfield, 1933: 178). This idea is especially relevant in the context of idioms and the lexicon. A discussion on whether or not idioms behave as words can be found in Vegge (2011). A claim in this work is that some types of idioms are ‘wordlike’ in the sense that they convey a single meaning and they are quite syntactically inflexible (Vegge, 2011: 7). These are noncompositional and correspond to the type established by Nunberg et al. as idiomatic phrases (Nunberg et al. 1994: 497). They are reluctant to syntactic change and could thus be entered in the lexicon according to the

constituent that determines their syntactic category, e.g. *shoot the breeze* (V), *a piece of cake* (N) or *fit as a fiddle* (Adj).

This relates to Chomsky's *idiom rule* (1980) according to which idioms are generated in the same way as regular phrases i.e. by the base rules and according to their syntactic X^0 category. When a string is recognized as idiomatic rather than literal, the string is assigned a new analysis in deep structure. The implications of applying the idiom rule to e.g. *kick the bucket* are that regular syntactic and semantic properties of the individual items 'kick' and 'bucket' will be erased, the object NP (the bucket) will be incorporated into the V-node and the meaning 'die' will be assigned to the derived configuration and labeled VP (van Gestel, 1995: 85f). The approach proves applicable to noncompositional idioms, e.g. *kick the bucket* is listed in the lexicon as an intransitive verb with the semantic meaning 'die'.

Compositional idioms are more complicated cases for formal lexical representation because they are more flexible syntactically (cf. chapter 4). According to Jackendoff (1997), Chomsky works under the assumption that the meaning of a sentence is produced only by the meaning of constituents, their elements of content and the combination of these. This combination is based only on how syntactic structure is combined (Jackendoff, 1997: 48). A sentence such as (5) can be interpreted both literally and idiomatically. According to Chomsky, idiomatic interpretation of a constituent applies at deep structure, even though the idiomatic phrase may be "scattered" or discontinuous at surface structure. The question then arises of how an idiomatic interpretation is achieved if neither lexical context nor extra-linguistic context can interfere in the interpretation of the sentence (cf. chapter 5).

(5) *The hatchet was finally buried.*

Some type of assistance seems necessary to distinguish between literal and idiomatic interpretation. Jackendoff proposes that both syntactic structures as well as conceptual structures (*LCS*, Jackendoff, 1997: 49) are involved in production of meaning. The challenge is to mark an expression as idiomatic in meaning, especially if it is discontinuous in a sentence. In the following subchapter I will present Jackendoff's framework of *Representational Modularity* (RM), which will prove useful in the analysis of idioms.

3.2 Representational Modularity

Similar to how we make sense of categories, systematically we also make sense of language (cf. chapter 2.3). The purpose of the lexicon is to store and keep track of lexical information which is accessed in the production of an infinite number of sentences. In order for this to happen, speakers need to remember which items can be combined and how they can be combined (Jackendoff, 1997: 109).

Jackendoff introduces conceptual structures as an integral part of lexical representation and also suggests that linguistic knowledge is separated into three different components in the mind. These are the *lexical phonological structure* (LPS), the *lexical syntactic structure* (LSS) and the *lexical conceptual structure* (LCS). These are autonomous derivations that relate to each other through interfaces or *correspondence rules*. These rules provide information about how components interact. The three components provide information about phonological, syntactic and conceptual structures and make up the structure of sentence as a triple <PS, SS, CS> (Jackendoff: 1997: 38). *The tripartite architecture* is an alternative approach to the structure of grammar and is illustrated in (6):

(6)

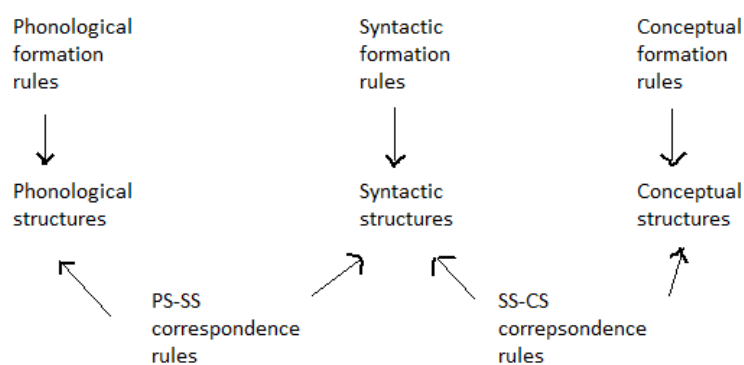

(Jackendoff, 1997: 39)

In line with this architecture Jackendoff develops a hypothesis about the organization of the human mind called *Representational Modularity* (cf. chapter 2, relates to how we also organize categories). It is an important claim of RM that language is represented in the mind by these separate entities of information. These components of information are referred to as *representation modules* and they make use of the *interface modules* for internal communication. Language production is thus dependent on the interaction of these modules.

The system Jackendoff presents is an attempt to provide an account of how our minds work when we produce and interpret language:

“The overall idea is that the mind/brain encodes information in some finite number of distinct representational formats or ‘languages of the mind.’ Each of these ‘languages’ is a formal system with its own proprietary set of primitives and principles of combination, so that it defines an infinite set of expressions along familiar generative lines. For each of these formats, there is a module of mind/brain responsible for it. For example, phonological structure and syntactic structure are distinct representational formats, with distinct and only partly commensurate primitives and principles of combination.” (Jackendoff, 1997: 41)

This architecture involves every aspect of human input and output, e.g. voice, emotion, vision, smell etc. However, in this thesis I only devote attention to the lexical interface which concerns the interaction of phonological, syntactic and conceptual structures. RM stands in contrast to Chomsky’s theory of lexical insertion. In an analysis that follows Chomsky’s theory, a lexical item is inserted into syntactic structure as a whole. This is not possible in RM, however, as the modules of linguistic information are separated and can only interact through correspondence rules. In order to achieve the goal of lexical insertion to formally represent lexical items, Jackendoff offers an alternative operation of *lexical licensing*.

Though Jackendoff makes use of much the same terminology of Chomsky, there are some crucial differences in application. “In short, *a lexical item is to be regarded as a correspondence rule and the lexicon as a whole to be regarded as part of the PS-SS and SS-CS interface modules.*” (Jackendoff, 1997: 89). In accordance with the idea that there are separate components of lexical information in the mind, lexical licensing formally analyzes a lexical item in three separate structures. These are the lexical phonological structure (LPS), the lexical syntactic structure (LSS) and the lexical conceptual structure (LCS) as mentioned. This is an essential difference between a structural analysis á la Chomsky and one that adopts RM, as depicted in (7).

(7) (a) *lexical insertion*

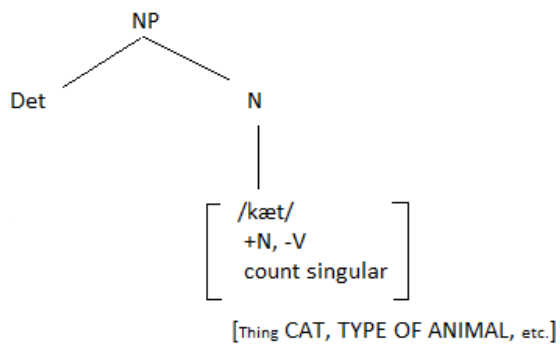

(Jackendoff, 1997: 84)

(b) *lexical licensing*

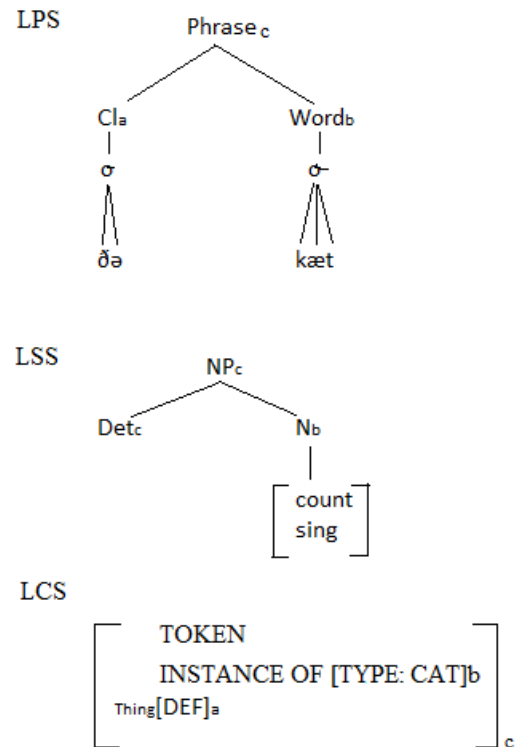

(Jackendoff, 1997: 88)

In (7a) the two different approaches to analysis are exemplified with the noun *cat*. (7a) demonstrates that lexical insertion mixes representations of phonological, syntactic and semantic information. In (7b), on the other hand, information is represented in separate structures according to lexical licensing.

The small-scale letters in (7b) are the *linking subscripts* which illustrate how these structures communicate. They demonstrate the correspondences between different information. These correspondences are licensed by the lexical items. Phonologic and conceptual information of an item is licensed but not visible in a syntactic derivation (Jackendoff, 1997: 90). In short, lexical licensing presents separate but correlated structures of phonological, syntactic and conceptual information while lexical insertion combines all in one structure.

3.3 Lexical licensing of idioms

The previous subchapter explained how a lexical item in the form of a single word is treated by lexical licensing. However, the main issue in this thesis is the treatment of idioms. As asserted previously in this thesis idioms create challenges for linguistic analysis and the formulation of lexical entries. For one, they are phrasal expressions, thus larger than X^0 categories. Another problematic issue is their interpretation as either noncompositional or compositional. In this chapter I will present Jackendoff's contribution to these issues. He recognizes and asserts the need to include phrasal expression in the lexicon. This is necessary to account for the existence of conventional expressions that are well established as units.

Many idioms can be treated as lexical items similarly to those that undergo lexical insertion. (8) can be analyzed as illustrated in (9) and incorporated in the lexicon as a verb with the single meaning 'die'.

(8) [VP[v kick] [NP[Det the] [N bucket]]]

(Jackendoff, 1997:161)

(9)

LPS

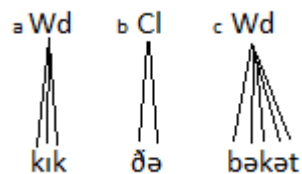

LSS

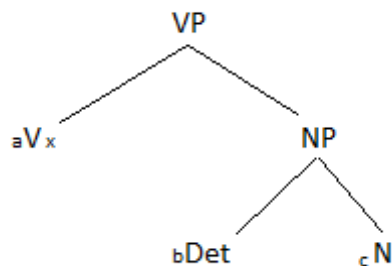

LCS

[DIE ([])_A]_x

(Jackendoff, 1997: 169)

Also in this approach an idiom retains its noncompositional interpretation. In an analysis of the idiom *kick the bucket* there is no separation of constituents. The NP *the bucket* has no argument status (*theta role*) in this interpretation. Consequently, *the bucket* must be syntactically attached to the verb *kick*. The implication of this is that movement of the NP is impossible, e.g. **The bucket was kicked by John* (Jackendoff, 1997: 166). A literal analysis of this phrase NP *the bucket* would be assigned a theta-role and thus it would not be attached to V. The LPS in (9) shows how the phonological constituents are linked to the syntactic features in the LSS. Though associated with their phonological representation in the LPS, the nodes aV_x, bDet and cN indicate no correspondence to any features in the LCS. This expresses the association of the phrase with one element, rather than three (Zeller, 2001: 22f). The idiomatic interpretation ‘die’ is thus marked in the interface between LSS and LCS by subscript x.

The structure in (10), which underlies the idiom *take X to the cleaners*, is similar to that of (8) insofar as the idiomatic interpretation is expressed by the lack of correspondence between certain parts in the LCS to the LSS, as shown in (11).

(10) [VP[V take] [PP[P to] [NP[Det the] [N cleaners]]]]

(11)

LSS

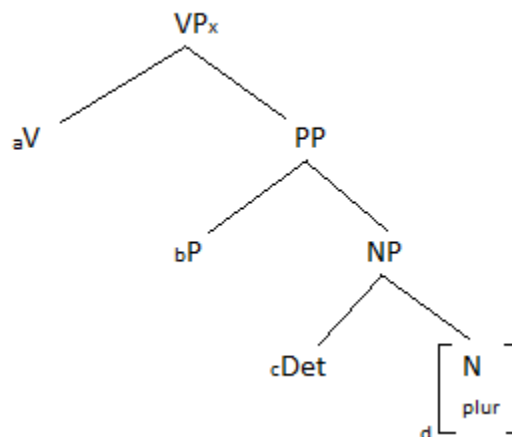

LCS

[Event GET ([]A, [ALL OF [MONEY OF []A])]]x

(Jackendoff, 1997: 162)

Though the whole of the expression corresponds to a single meaning (subscript x), the internal structure of the idiom is more complex as it is an example of an idiom that can occur as discontinuous. The discontinuity is marked by the first *postsubscript* A in the LCS. The transitive form of the verb *take* requires an object in order to be complete. Both postsubscripts represent slots that are linked to external arguments in the sentence, the subject and object position (Jackendoff, 1997: 162).

This idiom is an example of a slightly more syntactically flexible expression as it allows for an intervening object to appear, e.g. John *took him to the cleaners*, which freely undergoes passivization, e.g. He was *taken to the cleaners* by John. Also, the idiom *bury the hatchet* (12) allows for a great deal of flexibility. This idiom consists of parts which carry independent meaning that contribute to understanding the overall meaning of the idiom. Idioms of this type give rise to the claim that some idioms are compositional (Nunberg et al., 1994: 499f). In (12), constituents of LSS are linked to two different conceptual components in the LCS. In this example *the hatchet* does have argument status in the LCS, thus both *bury* (reconcile) and *the hatchet* (disagreement) receive independent meanings, expressed by the subscripts x and y. NP is connected to V via its theta role, but there is a syntactic separation between them which expresses the syntactic mobility of the NP (Jackendoff, 1997: 169).

(12)

LPS

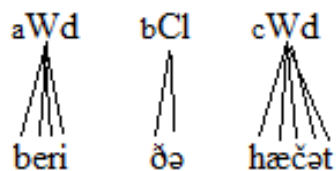

LSS

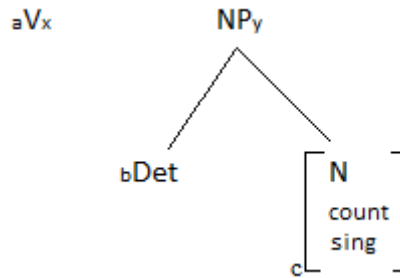

LCS

[RECONCILE ([]_A, [DISAGREEMENT]_Y)]_X

(Jackendoff, 1997: 168)

To sum up, Chomsky has provided a useful toolkit for lexical analysis by introducing the lexicon, lexical entries and lexical insertion. Though applicable in many cases, his program is in need of some improvement. Lexical licensing offers a solution for idiomatic interpretation as well as for literal interpretation since both can properly be represented in different formal structures. Lexical licensing also accounts for both noncompositional and compositional idioms in the lexicon. This is demonstrated in the examples above by their different argument structures. As we have seen so far, the compositional idioms prove the most difficult expressions to handle.

In this chapter, I introduced an alternative to lexical insertion. The need for an alternative approach is warranted by the variant forms and functions of idioms. Idioms appear as many different syntactic categories; however idioms in the form of VP seem to be most prone to variation (13), as opposed to e.g. NP (14) idioms or PP idioms that function as adjectives (15). (* indicates loss of idiomatic interpretation).

- (13) a. They wanted to *bury the hatchet*
 b. After a long time *the hatchet was buried*
 c. *The hatchet* was finally *buried* after he apologized.

- (14) a. It is a *blessing in disguise*.
 b. * He *disguised the blessing* very well.
 c. * The *blessing* was in *magnificent disguise*.

- (15) a. He was *on the dole*.
b. * *The dole* he was *on* was a tough one.
c. * *The dole* was not pleasing to be *on*.

In this chapter I have stated that one problem with idioms is their assorted forms. The next chapter concerns ways in which the structure of idioms can be altered. Some idioms seem to behave similarly to literal expression in the sense that they are amenable to syntactic operations. In the remainder of this thesis I will explore the variant behavior of compositional idioms in the form of verb phrases.

4. The flexibility of verb phrase idioms

In addressing the issue of idioms and lexical representation, the previous chapter pointed out that this issue is problematic because idioms come in many forms. Also, certain idioms are amenable to syntactic change in the sense that they can undergo certain syntactic operations and still retain their idiomatic interpretation. With literal phrases these types of changes would infer that they have an internal semantic structure. In many generative accounts, idioms are treated as units with no such structure (Gazdar et al. 1985: 237). However, some linguists challenge the claim that idioms are altogether noncompositional and assert the importance of semantics in idiom analysis.

“Modification, quantification, topicalization, ellipsis, and anaphora provide powerful evidence that the pieces of many idioms have identifiable meanings which interact semantically with each other.” (Nunberg et al., 1994: 14).

The possibility of modifications and transformations provide evidence for the claim that certain idioms are semantically compositional. Modifiers often function as intensifiers of idiom parts. Topicalization and passivization demonstrate that some idiom parts can occupy various positions in a sentence and certain idioms seem to survive lexical substitution. These operations reveal that idiom parts display meaning and that they can occupy different positions in a sentence. This chapter explores modification, transformation and lexical substitution of VP idioms and the influence of these operations on idiomatic interpretation.

4.1 Modification and quantification

Wasow et al. (1980) demonstrate semantic compositionality of certain idioms by pointing to internal modification. For one, idioms can be modified internally by means of e.g. adjectives (16) or relative clauses (17) (Wasow et al. 1980). The modifier in these cases affects only one part of the idiom implying that these parts carry meaning.

(16) leave no *legal* stone unturned

(17) Pat got the job by pulling strings *that weren't available to anyone else*.

(Wasow et al., 1980: 91)

Nicolas (1995) opposes this view. In his article “Semantics of Idiom Modification” we find an account of the internal modification of idioms in which one of his main concerns is to clarify the difference between syntactic and semantic modification. As a consequence, he argues that internal modification is purely syntactic i.e. idioms are noncompositional.

Based on the work of Verhagen (1990) and Arnold and Sadler (1989) he claims that adjectives used as modifiers in V-NP are adverbial modifiers of the whole idiom. As demonstrated in (18) *close* syntactically modifies *tabs*, but semantically it modifies the whole idiom as demonstrated in (19). Generally, this is not the case with modification of literal sentences. (20-21) show that the function of the modifier *expensive* can only apply to *wine*.

(18) They kept *close* tabs on John.

(19) They observed John *closely*.

(20) They kept *expensive* wine in the cellar.

(21) * They kept wine in the cellar *expensively*.

(Nicolas, 1995: 236)

Nicolas groups V-NP idioms into seven different categories according to their grammatical features and then he examines the compatibility between these and 8 different types of adjuncts as modifiers (Nicolas, 1995: 240). Through introspective testing and corpus searches, he verifies that the modified idioms are well-formed and also that it is possible to produce equivalent sentences with adverbial modifiers. Based on the results he concludes that internal modification is only syntactic and that the presupposition of internal semantic structure of idioms is superfluous. He demonstrates how a V + the + N' idiom can be paraphrased with an adverbial modifier. The modifier then applies to the meaning of the whole idiom (22).

(22) a. call the *political* tune

b. dominate *politically* speaking

(Nicolas 1995: 239)

Modification may be semantically external in some cases; however I am not convinced that Nicolas' argument disproves semantic internal modification of all idioms. There are examples (23) that counter this claim and cannot be paraphrased similarly to (22).

- (23) a. bury the *political* hatchet
 b. *reconcile differences *politically*
 c. reconcile *political* differences

In (23) the modifier must refer only to *hatchet* in order for the phrase to be equivalent. This therefore demonstrates a degree of internal semantic structure of the idiom. Note that Ernst (1981) makes a similar claim. He states while some inserted adjectives can be interpreted as external modification (*domain delimiters*, e.g. *emotional, musical*), there are also others (e.g. *small, rudimentary*) that must be analyzed as internal as in (24-25) (Ernst, 1981: 53f). This is especially evident in cases of quantification. (23-25) demonstrates that it is possible to quantify parts of idioms without abstracting their idiomatic meaning.

- (24) To come up with a decent presentation we were reduced to scraping the bottom of
every single barrel.
 (Ernst, 1981: 52)

- (25) He cut through *a lot of* red tape.
 (Pulman, 1993: 252)

The quantifier (24) applies to *barrels*. The meaning of this phrase is not simply to make an exhaustive search, rather it expresses that every single place has been searched (Ernst, 1981: 56). Also in (25) it is the amount of tape rather than the action that is quantified (Pulman, 1993: 252). An idiomatic reading of this sentence implies that the reader interprets part of the idiom as a constituent that contributes on its own to the whole expression. Thus, the collocation of the quantifier and the constituent part of the idiom indicate idiomatic extensions of these nouns (Gazdar, 1985: 237).

The internal modification of idioms must be represented by semantic interpretation on both idiomatic and non-idiomatic level. The meaning of a constituent on the idiomatic level corresponds to a literal meaning on the non-idiomatic level (26). Consequently, the constituents must carry meaning independently also in an idiomatic sense.

(26)

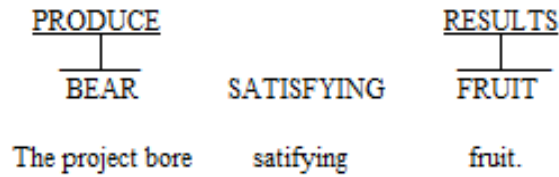

(Ernst, 1981: 58)

This analysis shows how the modifier applies to a constituent part of the idiom, which must mean that this constituent carries meaning. It is also possible to show that some idioms have meaningful constituents with certain transformations.

4.2 Transformations

According to Wasow et al. (1980):

“[...] the pieces of an idiom typically have identifiable meanings which combine to produce the meaning of the whole. [...] We contend that the syntactic versatility of an idiom is a function of how the meanings of its parts are related to one another and to their literal meanings.” (Wasow et al., 1980: 91)

They argue that idioms are amenable to transformations because they appear in different syntactic structures. If sentences such as those in (27 a, b) are transformed and still carry the same meaning, then they must be instances of the same idiom. If they are not, then there must be two different interpretations (Wasow, 1980: 87).

- (27) a. Pat spilled the beans
b. The beans were spilled by Pat.
(Wasow et al., 1980: 87)

4.2.1 Passivization

(27) illustrates a change of voice from active to passive. While most noncompositional idioms cannot take passive, there are several other examples of compositional idioms that can, e.g.

(28). Gazdar et al. (1985) point out that accounts which describe idioms as having no internal semantic structure leave many unanswered questions. How certain idioms can appear in passive constructions is one of them.

(28) *Tabs were kept on Terry by the KGB.*

(Gazdar et al. 1985: 237)

The transformation of voice of a sentence from active to passive requires the main verb of the sentence to be transitive. The operation does not change the content of the sentence; it only offers two different ways to describe the interaction between agent and patient. In an active construction the agent is focused, while a passive construction raises the level of prominence of the patient, e.g. *John kicked the ball* vs. *The ball was kicked by John* (Langlotz, 2006: 249f). In contrast, the idiomatic meaning of *kick the bucket* is the verb *die* which is an intransitive verb and as such reluctant to appear in passive.

Following the phraseologists Burger (1973) Fleischer (1982) and Dobrovol'skij (1997), Langlotz presents factors that are supporting and constraining determinants in passive transformation of idioms (Langlotz, 2006: 250). Both the literal and idiomatic meaning are considered in this account.

“This list of supporting and constraining factors indicate that the minimum requirement for the passivization of a verbal idiom is the presence of a transitive relationship in both the literal and the idiomatic meaning: both literally and figuratively the idiomatic configuration must code an inherently dynamic interaction between an agent that functions as an energy source and a patient that functions as the affected element in the energetic interaction.”
(Langlotz, 2006: 250)

Basically, the passive transformation depends on how the idiom functions literally. As mentioned, the literal function of the verb in *kick the bucket* is transitive, however the idiomatic meaning refers to an intransitive process/action, thus it cannot be passivized; * *the bucket was kicked*. Those idioms in which the verb is transitive or whose meaning corresponds to a transitive action are amenable to passivization, e.g. *set the wheels in motion*

(start something) → *the wheels were set in motion*. Also discontinuous idioms (cf. chapter 3.3) in which there is an open slot for a patient can be passivized, e.g. *take NP to the cleaners* → *he was taken to the cleaners*. A factor that constrains passivization is that some idioms have elements that are not open to passivization, e.g. *shoot yourself in the foot* → **Himself* was shot in the foot (Langlotz, 2006: 251). Reflexive nouns cannot be subjects in literal expressions or in idioms. This constraint is thus grammatically based.

According to Langlotz, the last supporting determinant is the most interesting and it concerns idioms that “consist of transitive verbal idioms with a lexically specified patient-slot: *grasp the nettle, spill the beans, kick the bucket, bite the dust* [...]” (Langlotz, 2006: 251). In order for these to be amenable to passivization they must be semantically compositional, and only some of them are. To demonstrate the semantic roles of the constituents of this type of idiom Langlotz offers a model for analysis. In (29) the idiom has recognizable similar semantic roles to those in a literal analysis (cf. chapter 3.3).

(29)

{ SBJ }	<i>reconcile</i>	<i>differences</i>	meaning paraphrase
{ SBJ }	V	OBJ	grammatical relations
{ AGENT }	PROCESS	PATIENT	semantic roles
			idiomatic scene
↕	↕	↕	
{ AGENT }	PROCESS	PATIENT	literal scene semantic roles
{ SBJ }	V	OBJ	grammatical relations
{ SBJ }	<i>bury</i>	<i>the hatchet</i>	base-form

(Langlotz, 2006: 252)

The conceptual meanings of the constituents of the idiom (*reconcile differences*) relate to each other similarly to the constituents in the literal phrase *bury the hatchet*. These idioms can take passive and they are similar to their literal paraphrases in grammatical and semantic relations. In contrast, an analysis of the noncompositional idiom *kick the bucket* will not exhibit such correspondences (30-31). It is no use highlighting *the bucket*, because it has no semantic value on its own (cf. chapter 3.3).

(30)

{ SBJ }	<i>die</i>		meaning paraphrase
{ SBJ }	V		grammatical relations
{ AGENT }	PROCESS		semantic roles
			idiomatic scene
			literal scene
{ AGENT }	PROCESS	PATIENT	semantic roles
{ SBJ }	V	OBJ	grammatical relations
{ SBJ }	<i>kick</i>	<i>the bucket</i>	base-form

(Langlotz, 2006: 253)

(31)

<i>the differences/*</i>	<i>was reconciled / * was died</i>	meaning paraphrase
PASSIVE SBJ	PASSIVE-V	grammatical relations
PATIENT	PROCESS	semantic roles
		idiomatic scene
		literal scene
PATIENT	PROCESS	semantic roles
PASSIVE SBJ	PASSIVE-V	grammatical relations
<i>the hatchet/ * the bucket</i>	<i>was buried/ * was kicked</i>	base-form

(Langlotz, 2006: 253)

The extensions this model shows, relates to how idioms function syntactically. According to the literal meaning of their extensions, they are amenable to change into passive voice. I will in this thesis investigate some compositional idioms that I expect will be equally understandable in passive voice. Passivized idioms show that some idioms have constituents whose positioning in sentences is more free which indicates that those constituents carry meaning

4.2.2 Topicalization

The main argument for the reluctance of idioms to undergo certain syntactic transformations is that idioms are not composed of meaningful parts. Schenk (1995) argues that certain syntactic operations only apply to constituents that carry meaning. Thus, the reluctance of idiom parts to undergo an operation such as topicalization is evidence that they are meaningless (Schenk, 1995: 259f). He defends the position that idioms are noncompositional and explores them with different syntactic operations. Only the meaningful parts of a sentence can be topicalized as demonstrated in (32-33).

- (32) (a) He believes the unicorns to be *there*.
(b) *There* he believes the unicorns to be.

- (33) (a) He believes *there* to be unicorns.
(b) * *There* he believes to be unicorns.
(Schenk, 1995: 259)

In (32) *there* refers to a location i.e. they are locative adverbs that have semantic weight (Vitto, 2003: 173). The expletive *there* in (33a), on the other hand, acts as a dummy subject and has no meaning as (33b) illustrates (Radford, 1997: 179). Similarly, Schenk asserts that topicalization of idiomatic *the beans* (34b) is impossible. Perhaps awkward in composition, the idiomatic meaning of this construction is not completely lost.

- (34) a. John spilled *the beans*
b. * *The beans* John spilled.
(Schenk, 1995: 259)

There are also other examples that demonstrate topicalization of idiomatic constituents (35-36). Wasow et al. (1980) acknowledge that it makes no sense to bring a meaningless constituent into focus. Thus, the possibility for a constituent to be topicalized indicates that the idiom parts involved carry some kind of independent meaning that contributes to the overall meaning of the idiom. Based on this observation, I assume that idioms presented similarly to those in (35-36) can still be interpreted idiomatically.

- (35) *Those strings* he wouldn't pull for you.
 (36) *Those windmills* not even he could tilt at.
 (Wasow et al., 1980: 91)

Topicalization shows how constituent idiom parts are meaningful because certain idioms are amenable to this transformation. A transformation that does not seem to be applicable to idioms, however, is subject control.

4.2.3 Subject control

Schenk (1995) claims that also subject control shows that idiom parts are meaningless. This operation requires that certain parts of the idiom involved carry meaning. In a control structure such as (37) there is a controller (Pete) and a contree (John). In (37 a) *John* is not attached to spill the beans, so this constituent may be part of a control structure (37 b), as opposed to *the beans* (38) (Schenk, 1995: 261).

- (37) a. Pete instructs *John* to spill the beans
 b. *John* tries to spill the beans
- (38) a. * John instructs *the beans* to be spilled.
 b. * *The beans* try to be spilled.
 (Schenk, 1995: 261)

In subject control structures, the controller is necessarily animate or a volitional agent (Gazdar et al. 1985: 241). Schenk's claim is accurate to some extent, because it appears as though idioms are not amenable to this operation despite seemingly animate parts (39). However, in an idiomatic interpretation of this sentence *the cat* represents something non-animate (the secret). It has been claimed that almost all idiom parts have such non-animate extensions, with a few exceptions (40) (Gazdar et al. 1985: 241). Thus, I do not see this as an argument against semantic compositionality of idioms, because parts may well carry meaning without having an animate role. Rather, it is merely an example of a syntactic operation that most idioms are reluctant to undergo because of their lack of non-animate extensions.

- (39) a. John instructs *the cat* to be let out of the bag
 b. * *The cat* tries to be let out of the bag
- (40) a. John instructs *the piper* to get paid.
 b. *The piper* wants to be paid.
 (Gazdar et al., 1985: 241)

All other transformations mentioned here demonstrate that certain idioms are amenable to change. The examples presented demonstrate that idiom parts can be analyzed individually and in many cases the parts are necessarily associated individually with separate extensions. These observations serve as support for semantic compositionality along with lexical substitution, which is discussed in the next subchapter.

4.3 Lexical substitution

Lexical substitution in idioms is a difficult subject to make claims about, because the extent to which an idiom can be altered without losing its idiomatic interpretation depends on the hearer. However, certain observations have been made that are worth exploring.

First of all, there are many idioms that have established variations e.g. *hit the hay (sack)*, *lose one's mind (marbles)*, *keep (lose, blow) one's cool* (Nunberg et al., 1994: 504). The corresponding semantic roles and syntactic features of the elements make substitution unproblematic in these cases. Also, the examples do not represent drastic change in idiomatic meaning. Another interesting observation concerns the transparency of some idioms. Wasow et al. (1980) recognize that the idiom *pull strings* is one that seems easy to comprehend in the sense that it has transparent constituents. The phrase is conventionalized; however its meaning is more accessible than e.g. a noncompositional idiom such as *shoot the breeze*.

According to Wasow et al. the constituents of some idioms hold their idiomatic meaning only in the domain of the other constituents of the idiom, e.g. the idiomatic sense of *strings* (connections) only holds in the domain of idiomatic *pull* (exploit). Thus, (41) should have no idiomatic interpretation, because here it relates to another part of the sentence (helped Chris get the job) (Wasow et al., 1980: 93).

- (41) *The strings* that Pat *pulled* helped Chris get the job.
 (Wasow et al., 1980: 93)

However, the idiomatic senses of *strings* and *pulled* in this sentence is recognizable, which means that *strings* must be allowed idiomatic interpretation in other domains. An implication of this is that a sentence like (42) must also allow for idiomatic interpretation.

(42) *Strings* helped Chris get the job.

(Wasow et al., 1980: 93)

According to van der Linden (1993) the treatment of idioms as compositional phrases with regular syntactic patterns produces problems. Because the constituents carry meaning; they can appear independently from the whole idiomatic expression and still retain their idiomatic meaning. *Strings* is assigned two meanings; one idiomatic i.e. *connections* and one non-idiomatic i.e. *strings*. There must be restrictions on which elements can combine with the constituents to trigger their idiomatic interpretation (van der Linden, 1993: 12). In accordance, Stock et al. (1993) claim that this productivity is quite restricted. First, even though *crack the ice* is fully understandable as an idiomatic variant of *break the ice*, the version *fracture the ice* is not. Secondly, they argue that these substitutions are too random to be acknowledged as rules (Stock et al. 1993: 234).

I recognize that such cases may be contingent. However, as Wasow et al. propose, the idiomatic reading of sentence (42) is due to language use. The practical use of language and frequency are factors that determine the interpretation of expressions. A well-formed idiom such as *spill the beans* will thus be used more often in its idiomatic sense than in its literal sense (Chafe, 1968: 111). This entails that idioms have constituents that are assigned idiomatic meaning even in irregular use. Following Langlotz (2006), I suggest that restrictions on combinations can be related to idioms and lexical keys (Cacciari/Tabossi, 1988). Langlotz (2006) suggests that this is one reason for why lexical substitution of idioms is possible, because distinct key constituents in idioms are recognized and these trigger idiomatic interpretation. In this sense, I agree with van der Linden that the individual meaning of idiomatic constituents is derived from the ability to recognize the meaning of the whole idiom. However, because these expressions are so familiar and integrated in language, I expect that their parts can function on their own in language. This is corroborated by lexical substitution. Because idioms of this type (43) are syntactically well-formed, restrictions are set by conceptual correspondences that induce the association of the idiomatic and literal meaning in idiom parts. These correspondences thus block defective combinations.

(43) This is the entrance to Turbo Ted's Nursery. British Rail is dipping its toes into *child care*.

(K1S: 2813 in Langlotz, 2006: 272)

In (43) the meaning *acting with uncertainty* is the intended and still present meaning of the phrase *dipping one's toes into the water*. Langlotz explains this substitution in terms of *topic-indicating lexical substitution*. The constituents *child care* and *water* are related by isomorphism because they are similar in function. The 'new' topic represents the same conceptual meaning of *water* (a place where one feels insecure). The topic is concretized with substitution, but the idiom remains (Langlotz, 2006: 272). According to Langlotz, there are conceptual metaphors related to the idiom which help explain how the constituent can be replaced.

“DIFFICULT PURPOSEFUL ACTIVITY IS SWIMMING, INSECURITY IS WATER and INTENSITY OF INVOLVEMENT IN AN ACTIVITY IS DEPTH OF POSITION WITHIN A CONTAINER (WATER/SWIMMING POOL = CONTAINER IN WHICH SWIMMING TAKES PLACE), the constituent water can be attributed the phrase-induced figurative meaning NOVEL, DIFFICULT ACTIVITY/ISSUE WHICH THE ACTOR FEELS INSECURE OF”. (Langlotz, 2006: 272)

In this sense, the agent of the action described in the sentence is *British Rail* while the topic is *child care*. Langlotz also demonstrates topic-indicating lexical substitution with an adnominal version of the idiom (44). The sentences are synonymous and the idiom is intact in both.

(44) (a) Just when we thought it was safe to dip a toe into the *poll tax* water, we are faced with a poll tax mark II.

(HHW: 5161 in Langlotz, 2006: 273)

(b) Just when we though it was safe to dip a toe into the *poll tax*, we are faced with a poll tax mark II.

(Langlotz, 2006: 273)

We also find lexical substitution in the form of perspectival variation, e.g. *get the show on the road* vs. *keep the show on the road*. Though slightly altered in meaning, the idiom is still intact. The same applies to idioms in which constituents are replaced by synonym variants, e.g. *skate on thin ice* or *tread on thin ice*, *loose one's marbles* or *loose one's mind*.

Interpretation of the idiomatic phrase is dependent on the conceptual correspondences it holds to the literal meaning of movement and place of danger (Langlotz, 2006: 274f). Lexical substitution of idioms is to some degree dependent on independent meaning of constituents, i.e. compositionality. Consequently, noncompositional idioms are fixed, but compositional idioms survive substitution in many forms and variations.

To sum up, the semantic properties of idioms help explain why some idioms can be altered while others cannot (Nunberg et al., 1994: 508). Their syntactic behavior relates to their semantic extensions. These extensions often have literal meanings which determine their syntactic behavior. I agree that some type of modification applies to the meaning of the whole idiom, but I reject the claim that modification is purely syntactic in all cases. Evidence that exhibits modification of idiom parts suggests that these parts are meaningful, thus they can be semantically modified internally, while noncompositional idioms are semantically modified externally. Compositional idioms have semantic internal structure and are thus amenable to various syntactic operations similarly to their literal counterparts.

Internal semantic structure is also a prerequisite for transformations of sentences. The fact that operations such as passivization and topicalization are applicable to some idioms provides evidence for the assumption that many idioms are compositional. Further evidence comes from lexical substitution. In conclusion, operations such as modification, transformation and lexical substitution serve as support for the claim that many idioms have internal semantic structure that helps explain their syntactic behavior. These statements should be put to the test with respect to idiom comprehension in practice. In the following chapter, I report on my experiment on idioms in some of these constructions.

5. Testing the flexibility of verb phrase idioms

In this chapter I will present the method and results from a pilot study I conducted, where two groups of test subjects were given a set of 20 sentences in which 13 idioms were presented in four different types of constructions. In this thesis I have supported the claim that compositional idioms are amenable to various syntactic alterations and that this suggests that they have internal semantic structure. This experiment was conducted with the intention of testing theoretical assumptions discussed in the previous chapter.

The study demonstrated that idioms were in most cases comprehended despite transformations. Passivization resulted in the highest number of instances not comprehended with idioms. The most interesting differences in comprehension between the groups were found in particular idiomatic instances. Also, there were distinct differences in the evaluation of appropriateness of the sentences. A few noncompositional idioms were also included to investigate the assumption that they are less likely to be interpreted idiomatically in transformations than compositional idioms.

The purpose of the study was to examine the effects transformations have on idiomatic interpretation. I test my hypothesis that compositional idioms retain their idiomatic interpretation in various structures.

5.1 Method

5.1.1 The test subjects

14 test subjects participated in this survey. The subjects belonged to two groups, each with seven participants. Group I consisted of university employees that are all non-linguists, but native speakers of English. Group II consisted of second year bachelor students of English that are non-native speakers of English.

5.1.2 The materials

The test subjects were asked to paraphrase sentences with idioms, ten of which were compositional and three noncompositional idioms in the survey. The idioms used were all verb phrases. In addition to these compositional idioms, *saw logs*, *shoot the breeze* and *kick*

the bucket were included and reckoned as noncompositional. Most expressions were examples of familiar idioms, with the exception of one noncompositional idiom (*shoot the breeze*) and one compositional idiom (*nails colors to the mast*) that were less familiar. The choice of idioms were based on my perception of them as familiar expressions due to my own intuition and language knowledge, but also the frequency of use as examples in published research materials. Less familiar expressions were mainly included to make the idiomatic structures less obvious.

The survey consisted of 20 sentences in which 13 idioms were represented as transformed in modification, quantification, passivization and lexical substitution. Some idioms were represented only once, while others were represented more than once but then in different constructions. The full set is provided in the appendix. The entirety of the survey carried 280 responses.

The idioms used in the survey:

Compositional

- 1. *bury the hatchet*
- 2. *drop like ninepins*
- 3. *keep tabs on*
- 4. *cross bridge*
- 5. *break the ice*

- 6. *let the cat out of the bag*
- 7. *throw in the towel*
- 8. *let sleeping dogs lie*
- 9. *bite one's tongue*
- 10. *nail colors to the mast.*

Noncompositional

- 11. *saw logs*
- 12. *shoot the breeze*
- 13. *kick the bucket*

5.1.3 Procedure

Subjects were given a questionnaire consisting of 20 sentences. They were asked to provide paraphrases that conveyed their initial interpretation upon reading the sentence. In addition, they were asked to answer how appropriate they considered the sentence to be. They were given three options for response: equally appropriate in written and spoken language, equally inappropriate in written and spoken language or only appropriate in spoken language. Group I answered the survey online (limesurvey.org) while subjects in Group II were gathered in a room where they answered the survey on paper.

Participants were not informed on the intention of the experiment in order to obtain the most realistic results of idiom comprehension. However, this also created difficulty as some misunderstandings occurred. Group I provided paraphrases in almost all cases, however there

were quite a few instances of no answer provided in Group II. Also, some subjects corrected the sentence or simply gave comments on the appropriateness of the sentence instead of providing paraphrases. Thus I had to make some assumptions about these responses. The cases which indicated that the sentence was interpreted literally were considered a negative response for idiom comprehension and appropriateness. The sentences which test subjects provided no answers for were also reckoned as not comprehended and inappropriate.

5.2 Results

5.2.1 The overall results

As mentioned the survey consisted of 280 instances in total. (45) illustrates the results of overall idiom comprehension in both groups. It shows that many idioms were comprehended in the survey despite the various transformations applied to them. However, test subjects did not consider the idioms to be appropriate to the same extent. In (46) the percentage of no answers provided must be considered along the same line as inappropriate as they are not comprehended. Examples evaluated as appropriate in spoken language are reckoned as appropriate. Thus 51% of the sentences are accepted, and the other 49% are not accepted. It is difficult to make any sorts of claims about the appropriateness of idioms based on these results. Therefore, it is necessary to explore the results in each group as well as the responses to each of the four different constructions.

(45)

Total comprehension

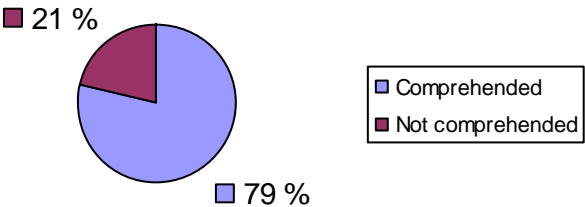

(46)

Total appropriateness

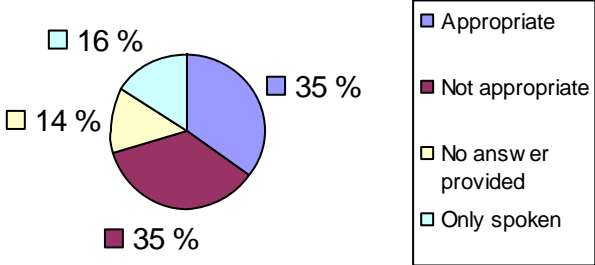

5.2.2 The groups

As the diagrams (47-48) below demonstrate, idioms were in most cases comprehended by all test subjects. In Group I 115 out of 140 idiomatic instances were comprehended and in Group II 105 out of 140. The lower number in Group II was due to the fact that only a few of the subjects provided answers for three idioms: *saw logs*, *shoot the breeze* and *nail colors to the mast*. Results from the two latter were not surprising as I had already reckoned them as unfamiliar. However, the high number of no responses for the first idiom was quite unexpected. The sentence (*Logs were sawn by John last night*) was considered inappropriate by 5 out of 7 test subjects in Group I. The reason for this might be that the idiom is not interpretable in passive. However, seeing that the subjects in Group II provided no paraphrase suggesting literal interpretation, I gather that this idiom was less familiar to the group of non-native speakers.

As for appropriateness, Group II displayed a higher number of appropriate sentences (48b). 22% of the test subjects in Group II gave no answer, which I interpret as ‘inappropriate’. Group distinctions are further explored in the following subchapter where results from the different constructions are examined.

(47) (a)

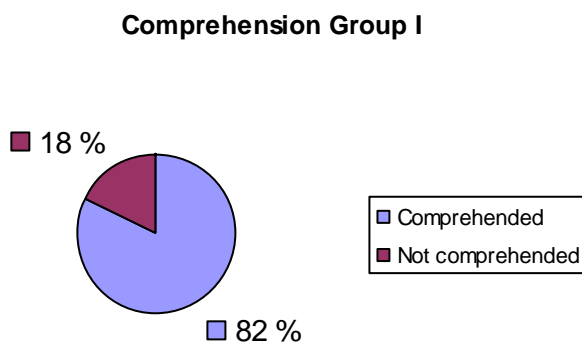

(48) (a)

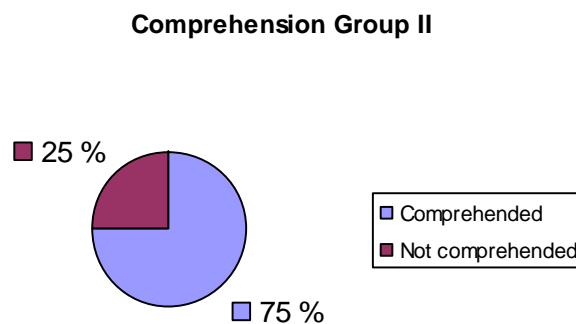

(47) (b)

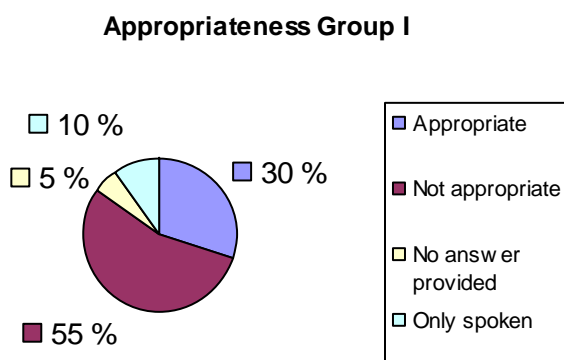

(47) (b)

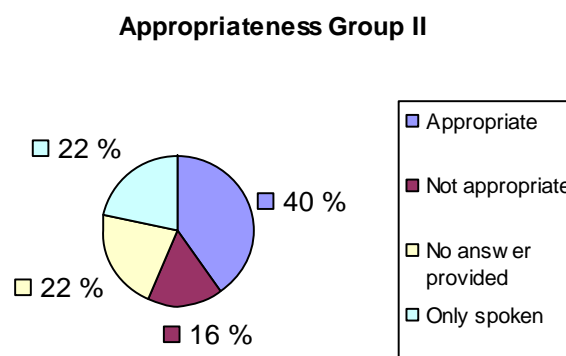

5.2.3 Types of constructions

Many idioms retain their idiomatic interpretation in various constructions as the diagrams above show. However, the study also demonstrated that there are differences among constructions as some showed a higher degree of idiom comprehension than others. Idioms that were modified or quantified proved to be easily comprehended. Although quantification proved more appropriate than modification, these results were divided.

The most conspicuous cases concerning comprehension were those with passivization. These also proved interesting with respect to the evaluation of appropriateness. Lexical substitution showed a remarkably high percentage of comprehension, however the difference between the groups concerning appropriateness were uncertain.

5.2.3.1 Modification and quantification

Both modification and quantification showed a high percentage of instances where the idioms were comprehended. It is thus safe to say that familiar idioms will most likely be comprehended in such constructions, e.g. *Those plans dropped like plastic ninepins* and *Nina had thrown in many towels in her lifetime*.

The evaluation of the appropriateness of such structures, on the other hand, was less straightforward. With modification judgment was split as 56% of the sentences were considered inappropriate while in total 44% were evaluated as applicable in some way (49b). Quantification proved more acceptable as 63% of the instances were considered appropriate (50b) (cf. chapter 4.1). Apart from suggesting that quantification seems suitable for idioms, it is difficult to reach any sort of conclusion on this issue. There are however some tendencies between the groups worth noticing.

(49) (a)

Modification - Comprehension

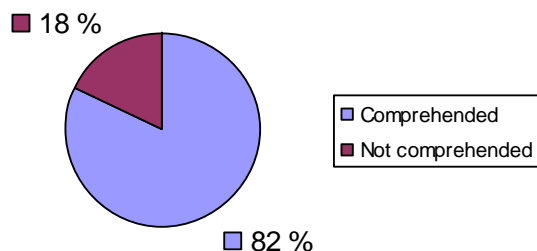

(49) (b)

Modification - Appropriateness

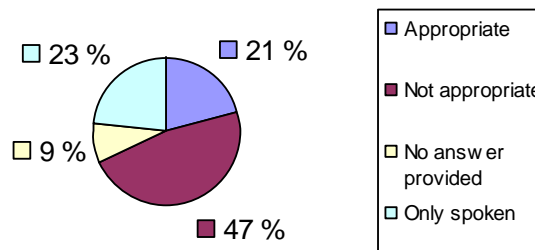

(50) (a)

Quantification - Comprehension

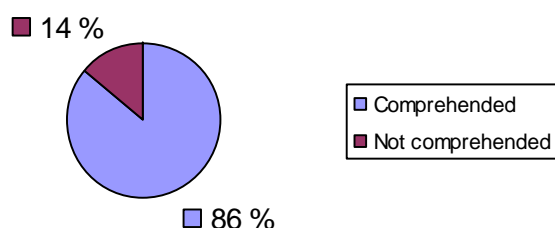

(50) (b)

Quantification - Appropriateness

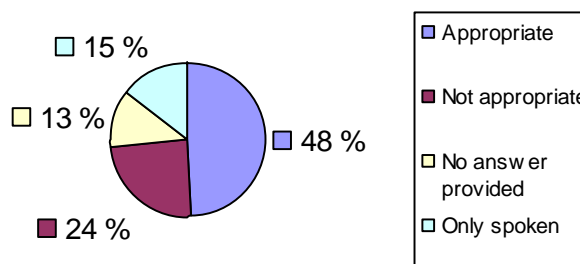

Modification showed 82% comprehended instances (49a). Overall, the idioms displayed similar results in comprehension and appropriateness as (51) shows. In quantification the overall comprehension and appropriateness of idioms were both fairly high (52). However, one of these example sentences was presented with an unfamiliar idiom: *John had many important colors he felt a need to nail to the mast*. In Group I six out of seven test subjects comprehended of the instances as opposed to one out of seven in Group II (53). Test subjects in Group II were obviously not familiar with this idiom. The idiom is also modified in this case, it is reckoned as quantified because the focus is on the many colors.

(51)

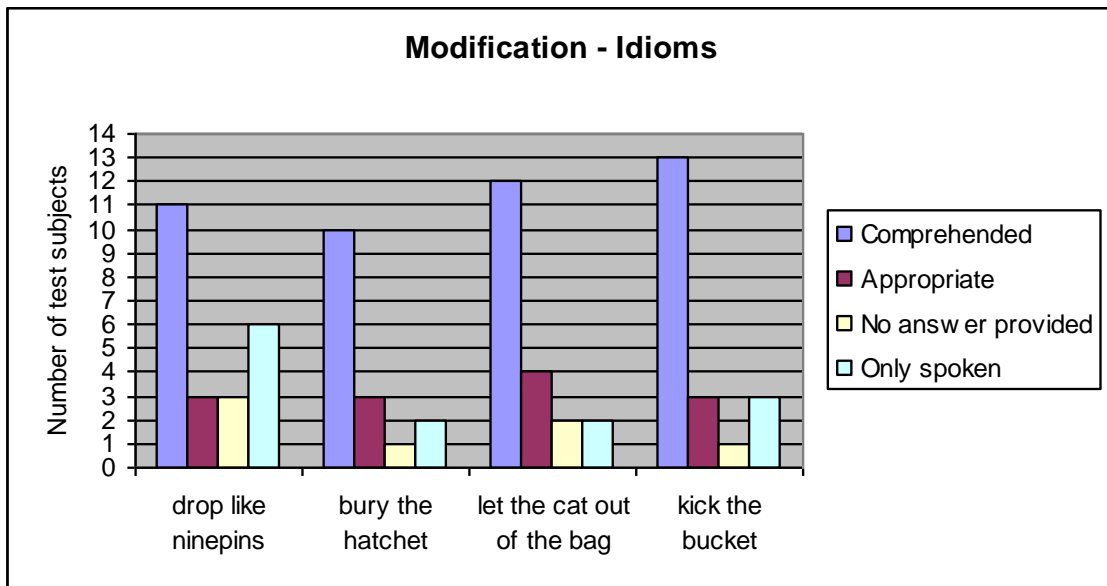

(52)

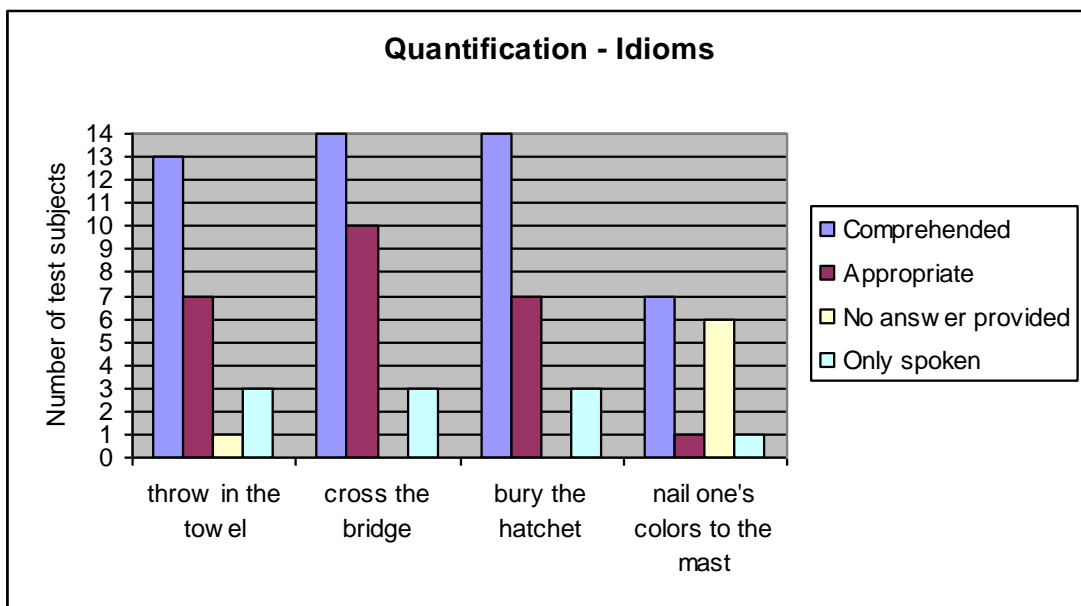

(53)

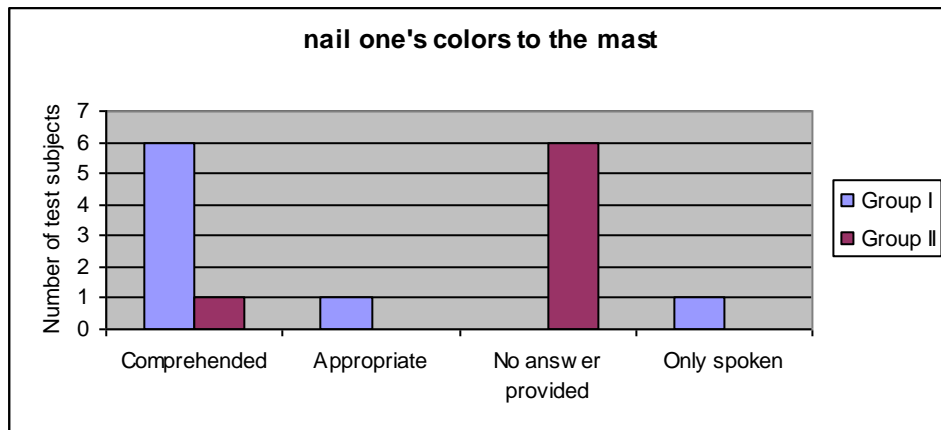

When it comes to the evaluation of appropriateness, the subjects in Group I were more reluctant to accept modified and quantified idioms (54). Subjects in Group II seemed to accept these structures (55), at least in spoken language. In this case, the differences may be due to different age groups or native and non-native speakers. I will comment on this later in this chapter after having examined results from other types of constructions and demonstrated tendencies that indicate a general difference in judgment between the groups.

(54) (a)

**Modification - Appropriateness
Group I**

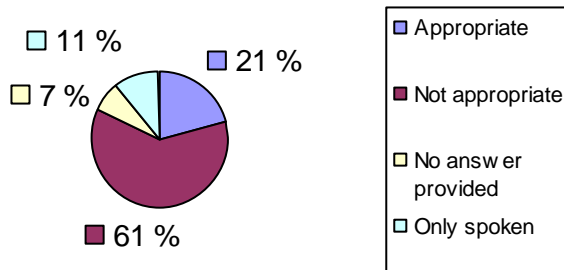

(55) (a)

**Modification - Appropriateness
Group II**

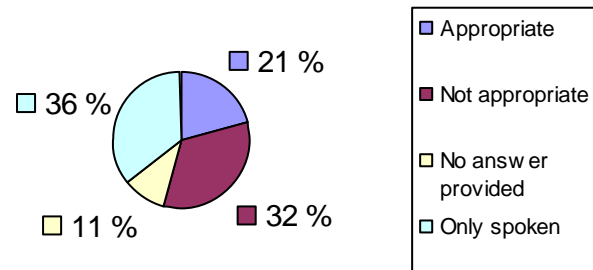

(54) (b)

**Quantification - Appropriateness
Group I**

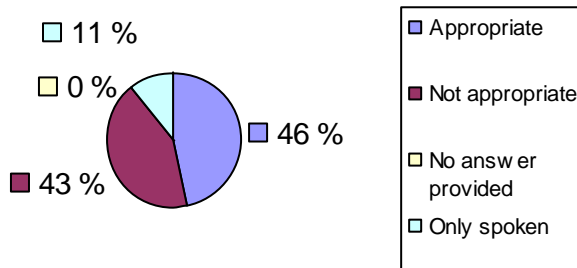

(55) (b)

**Quantification - Appropriateness
Group II**

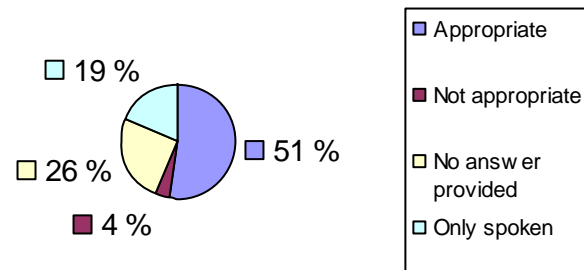

A particular instance with modification that proved interesting was the sentence in which a noncompositional idiom was modified: *Grandpa John finally kicked the long overdue bucket* (56). Most subjects understood the idiomatic meaning of this phrase. These results were unexpected as this is a noncompositional idiom. However, the idiom is very familiar and thus likely to be recognized by readers. Also, there is no clear literal counterpart to this sentence that could compete with the idiomatic reading. Still, these results contradict my assumption that the noncompositional idioms in altered structures would not be interpreted.

(56)

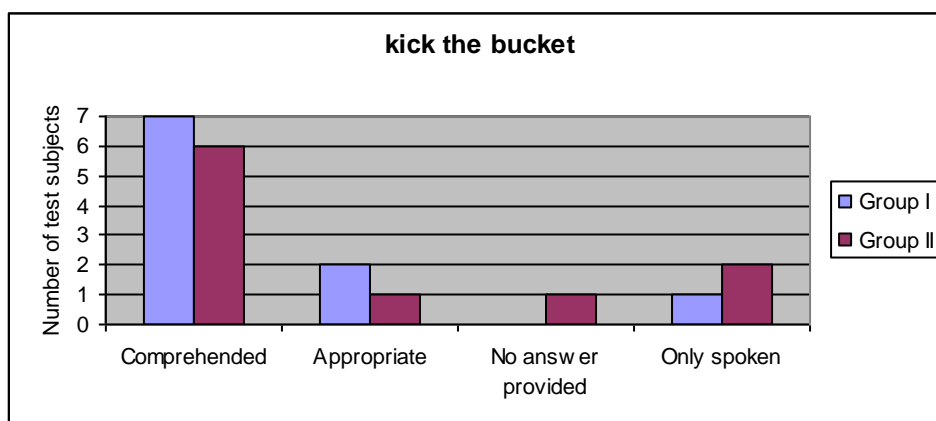

Sentences with modified and quantified idioms were easily interpreted by subjects as long as the idioms were familiar. The two operations demonstrate much the same change of idiomatic structure as one element affects an individual part of the idiom in some way, but there is no major change in relation to the original structure of the idiom. The constituents are still adjacent thus the idiom is perhaps recognized more easily. In comparison, transformations such as passivization and topicalization involve the rearranging of the structure of the idiom. As we will see in the next subchapter, sentences with these constructions exhibit a lower percentage of comprehension among test subjects.

5.2.3.2 Passivization

In contrast to e.g. modification, quantification and lexical substitution, passivization involves an intrusive change in the structure of the idiom. Idioms are thus presumably less obvious in this type of construction. I assumed it would be harder to identify tendencies of interpretation of passivized idioms. For this reason, I tested passivized in twice as many sentences as the other constructions. Also, I included the same idiom twice (*bury the hatchet*) to investigate irregularities in comprehension.

Total number of cases showed a lower percentage of comprehended idiomatic instances than with the operations discussed so far (57). Results from both comprehension and appropriateness show that opinions about idioms in passive voice are divided (58). Here, it is necessary to explore each instance of passivization in order to find explanations as to why these results occurred. Some interesting differences between the groups also emerged that we need to pay attention to.

(57)

Passivization - Comprehension

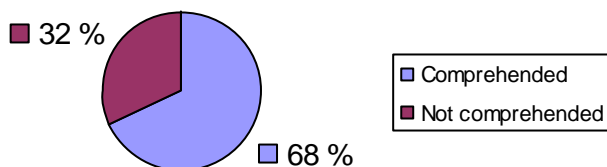

(58)

Passivization - Appropriateness

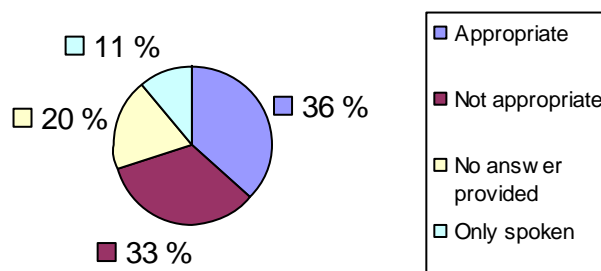

Group I displayed a higher percentage of comprehended passivized idioms than Group II. Out of all the instances of passivization 71% of them were interpreted idiomatically by test subjects in Group I and in Group II 64 % were comprehended. However, the subjects in Group I were still reluctant to accept these constructions (59). Differences between groups noticed in the previous accounts were thus also apparent here, as the total percentage of appropriate sentences was largely results from Group II (60). However, (60) illustrates that 32% of the passivized instances in Group II were not understood. Also in this case the results were influenced by instances of noncompositional idioms.

(59)

Passivization - Appropriateness Group I

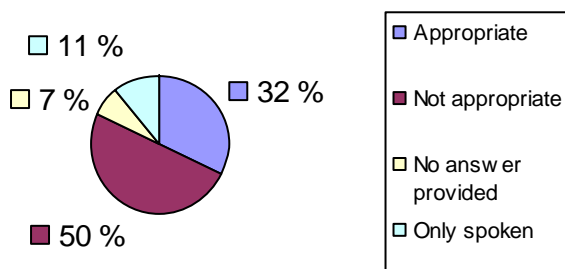

(60)

Passivization - Appropriateness Group II

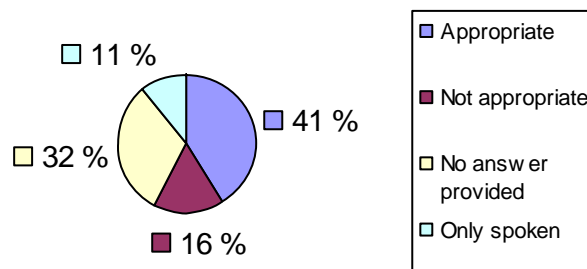

Idiom comprehension was low in three of the instances: *cross det.bridge*, *saw logs* and *shoot the breeze* (61). Only half of the test subjects interpreted a passivized construction of *cross det.bridge* as idiomatic. The sentence (*The bridge was crossed easily*) had a clear literal counterpart that was perhaps more obvious than the idiomatic interpretation as demonstrated by how many of the subjects interpreted the expression.

(61)

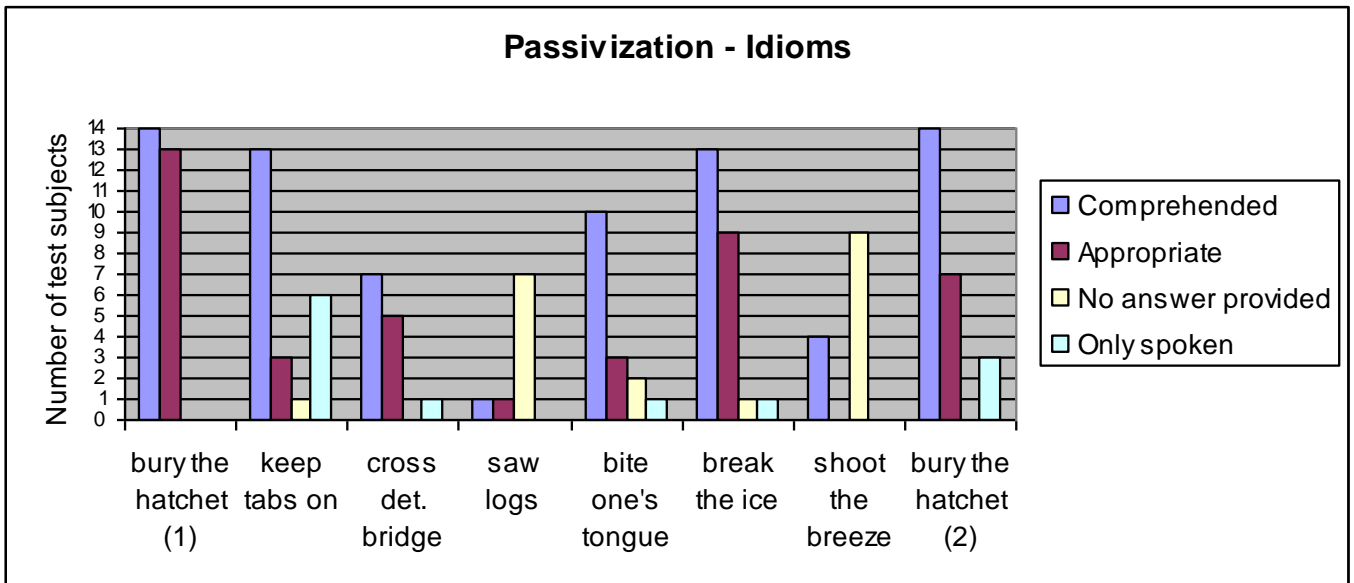

It is peculiar that most of the subjects that recognized the expression as idiomatic in this case were from Group II as (62) shows (*cross det. bridge*). The reason why mainly non-native speakers arrived at the idiomatic interpretation could be that they understood idioms as the common denominator in the survey, while the native speakers found the literal meaning the more obvious one. If this is so, than this example could be taken to show that the idiomatic meaning in some cases is blocked by literal interpretation. The other instance of *cross det. bridge* given in the survey was interpreted idiomatically by all subjects. Therefore it is likely that subjects found the idiom in passive voice unusual and the literal counterpart more obvious.

(62)

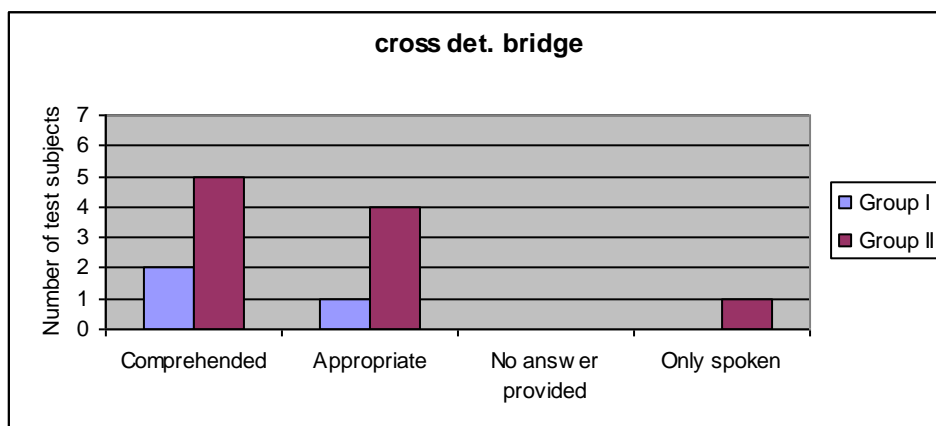

All cases of passivization of compositional idioms in the survey correspond to a transitive action: *bury the hatchet* (reconcile differences), *keep tabs on* (watch someone), *cross det. bridge* (solve problem) *bite one's tongue* (hold back opinions) and *break the ice* (stop tension). These also have a literal counterpart, which makes them more amenable to passive voice (cf. chapter 4.2.1).

What is highly interesting to notice in these results is that the most conspicuous cases of passivized idioms are noncompositional idioms. The passivized version of *saw logs* had great influence on the results as this was not appropriate as idiomatic or not comprehended. The majority of the subjects in Group I interpreted *saw logs* literally, while it was incomprehensible to all subjects in Group II. Only one out of 14 subjects comprehended the idiomatic meaning of the sentence *Logs were sawn by John last night*. All of these were native speakers of English from Group I (63). The idiom *saw logs* is apparently not well suited for passive voice, which makes sense because it corresponds to an intransitive action (sleep) (cf. chapter 4.2.1).

(63)

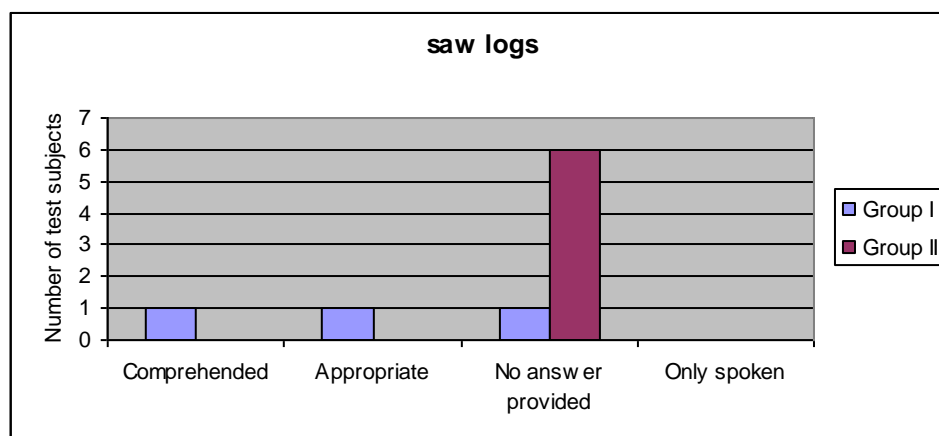

The same goes for *shoot the breeze* (chat). The diagram (64) shows that 6 out of 7 test subjects in Group II did not provide an answer to this sentence. I gather that this means that most of the subjects in Group II were not familiar with these idioms. The results from Group I in this case corroborate my assumption that noncompositional idioms are less amenable to transformation.

(64)

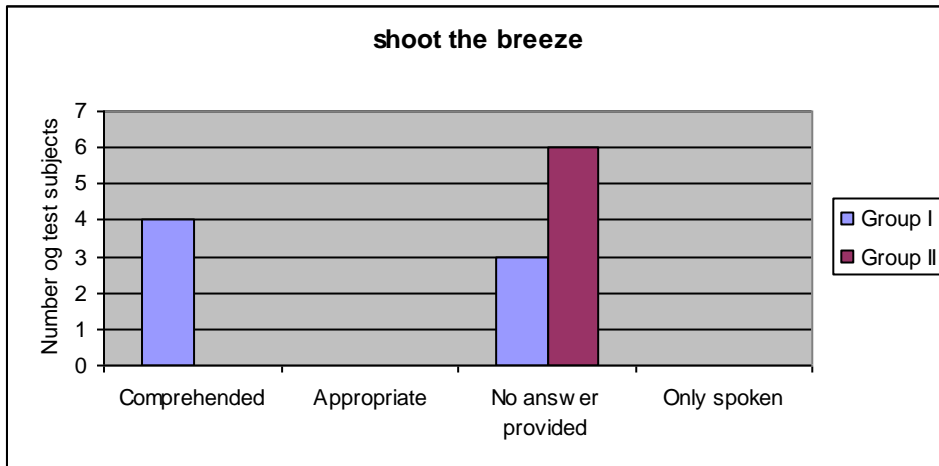

The sentence *Tongues were bitten throughout the meal* was comprehended by ten out of 14 subjects, but it was not considered very appropriate. However, an interesting observation made here was that both groups in fact showed similar comprehension results in the different idioms. Results from the other idioms also showed similarities in the evaluation of appropriateness. This could indicate that some idioms are more flexible than others, and also that there are different degrees of flexibility among compositional idioms.

The diagrams below show that both groups evaluated *keep tabs on* (67), *break the ice* (68) and both versions of *bury the hatchet* (66, 69) somewhat similarly. However, opinions were divided about the passivized versions of *saw logs* (63), *shoot the breeze* (64) and *bite one's tongue* (65). This is most likely due to the unfamiliarity of *saw logs*. The divergent opinions about the latter idiom mirror the earlier observed tendency of subjects in Group II to be more ready to accept idioms in different constructions than members of Group I.

(65)

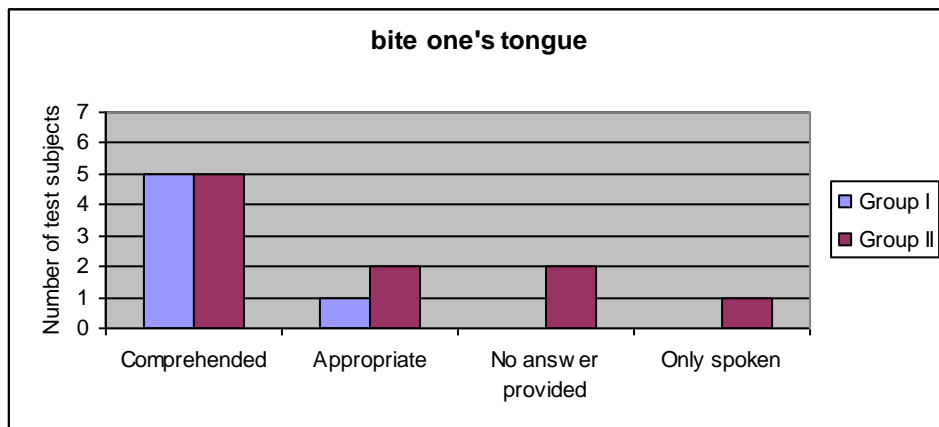

(66)

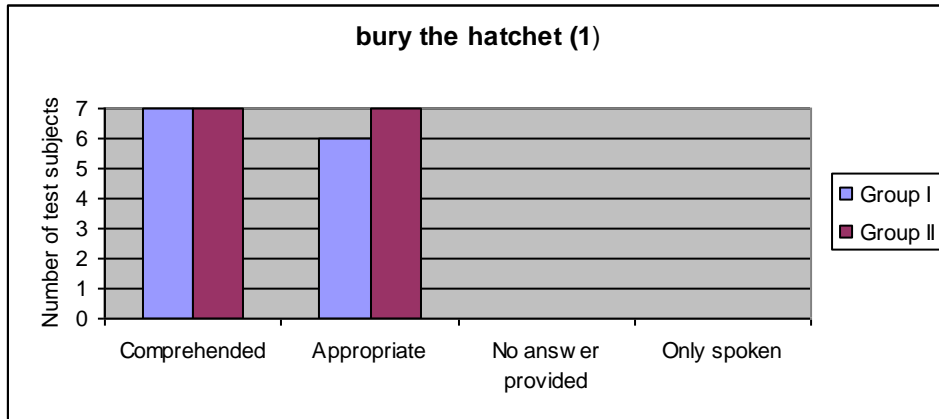

(67)

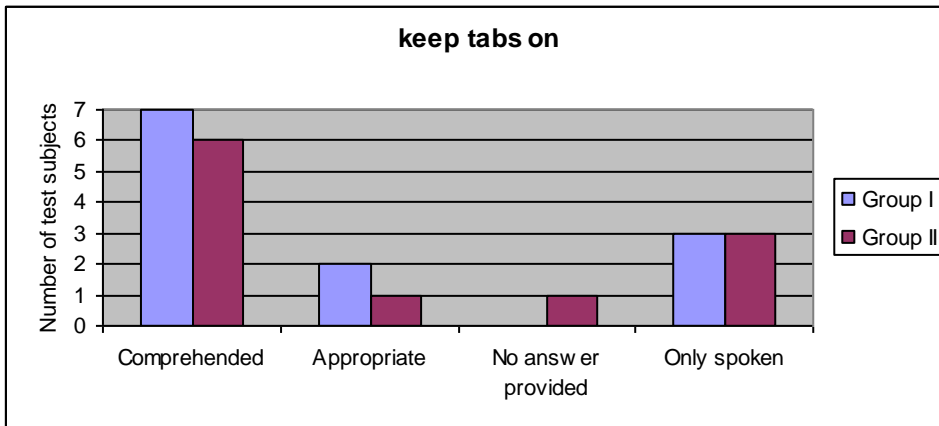

(68)

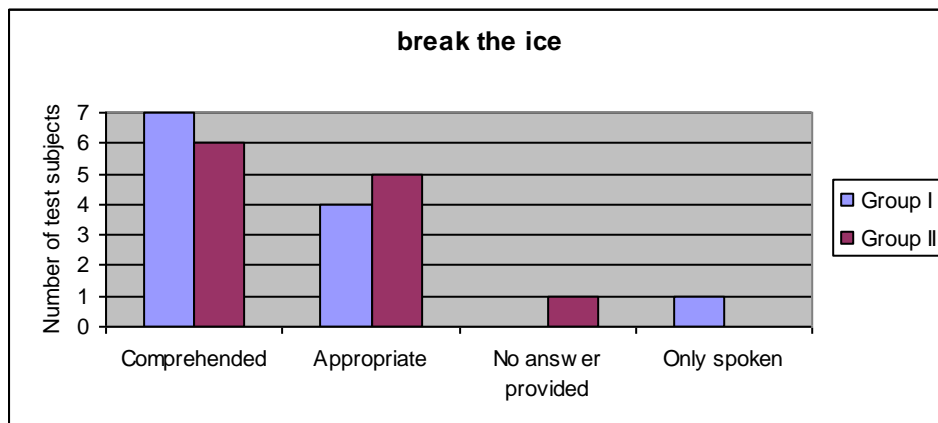

(69)

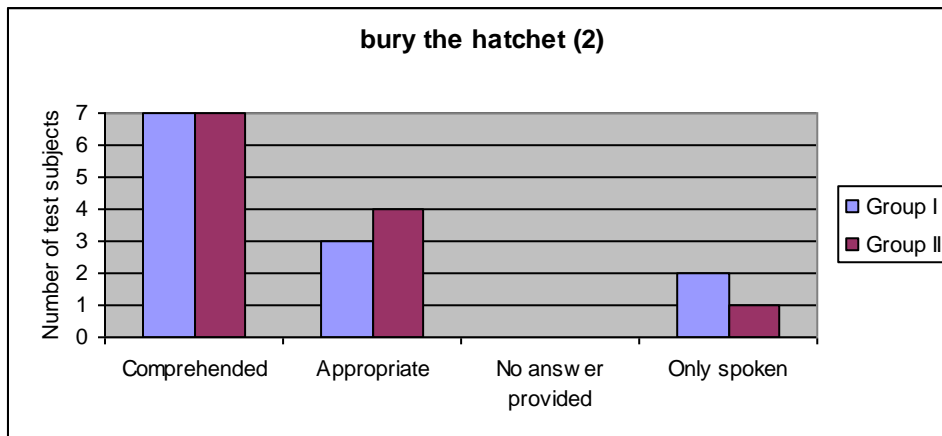

Compared to modification and quantification, passivization yielded well different results in comprehension. A closer examination of the results revealed that this difference was largely because of the noncompositional and unfamiliar idioms given in the survey. However, the total results from this transformation support my hypothesis that compositional idioms can occur in transformations. *Saw logs* and *shoot the breeze* set aside, transformed idioms are to a large extent comprehended. The assessment of appropriateness is more difficult to make claims about since there were no overwhelming numbers that supported one view.

5.2.3.3 Lexical substitution

Similarly to modification and quantification, lexical substitution involves small changes in the structure of the idiom. Based on the fact that idioms hold their meaning in the domain of individual constituents (cf. chapter 4.3) this type of change could result in loss of idiomatic interpretation. However, in this survey test subjects recognized the idioms in most cases. Both groups displayed a high percentage of idiom comprehension (70). Results from the evaluation of appropriateness were significantly different (71), however. Also in this case it is necessary to compare group results (72, 73) and explore idiomatic instances individually (74).

(70)

Lexical substitution - Comprehension

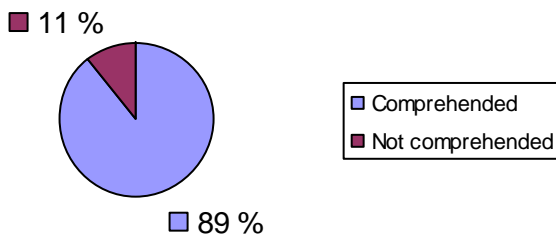

(71)

Lexical substitution - Appropriateness

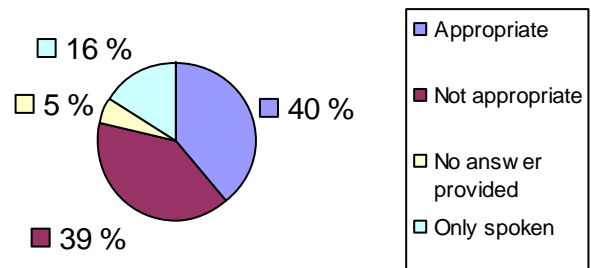

(72)

Lexical substitution - Appropriateness Group I

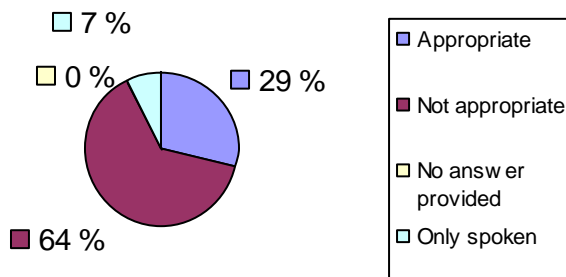

(73)

Lexical substitution - Appropriateness Group II

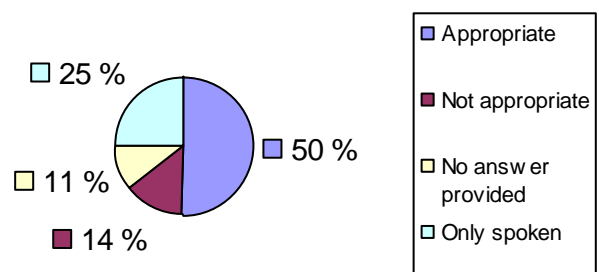

As illustrated in (74), no idiom stood out significantly in terms of comprehension. However, sentences were approved as appropriate by fewer subjects in comparison. In the first idiom *bury the hatchet*, the constituent *hatchet* was substituted with *axe*, and in *let the cat out of the bag*, the constituent *cat* was replaced by *horse*.

(74)

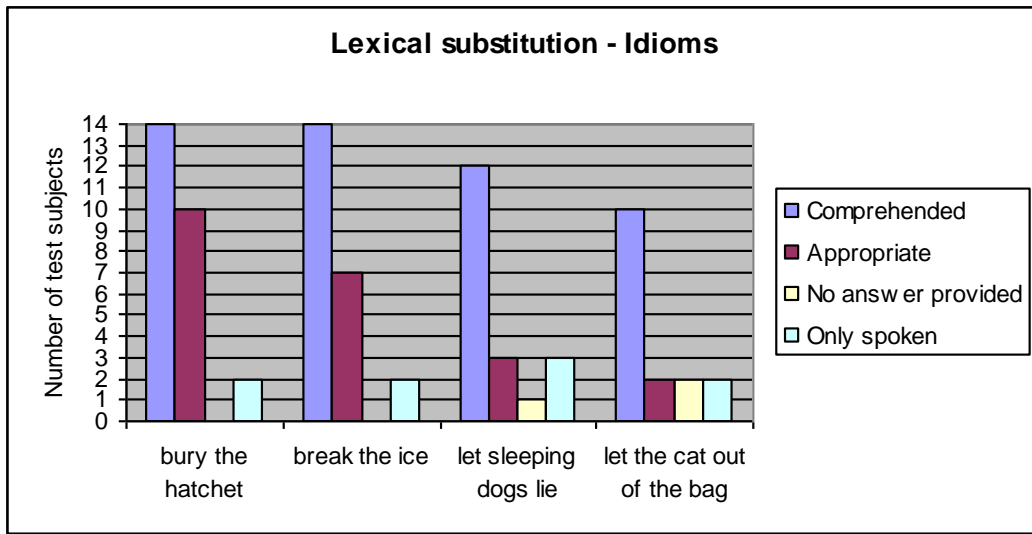

I see no formal reason as to why substitution should be more acceptable in *bury the hatchet* (75) than in *let the cat out of the bag* (76). The only explanation I can think is that a horse and a cat are more distinct entities than an axe and a hatchet. However, in both examples the substituting constituents carry the same syntactic function and semantic roles as the original, and the idiomatic meaning does not change. Further, I could identify only three test subjects that had a consistent pattern of not accepting lexical substitution as appropriate for idioms. Judgment in these cases might be based on unattractive sentences and intuitive language knowledge. The high percentage of inappropriate cases in Group I might be a result of the reluctance to approve of unusual constructions (72). Test subjects in Group II are perhaps more concerned with meaning when they judge appropriateness of sentences (73).

(75)

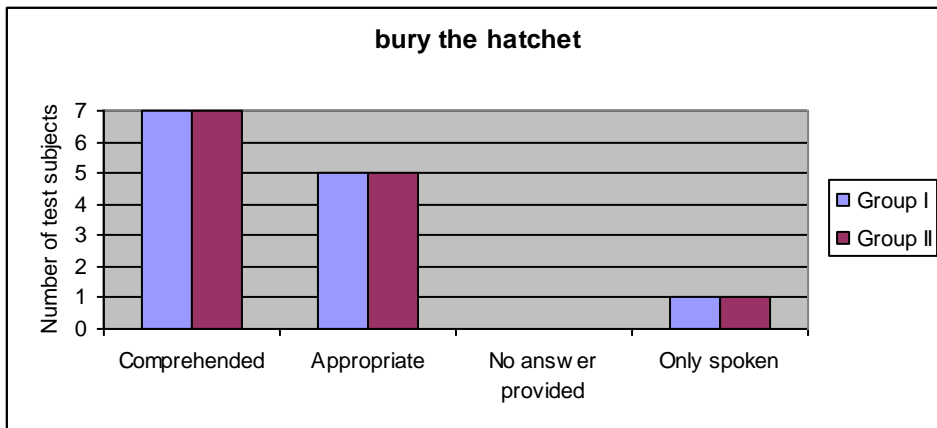

(76)

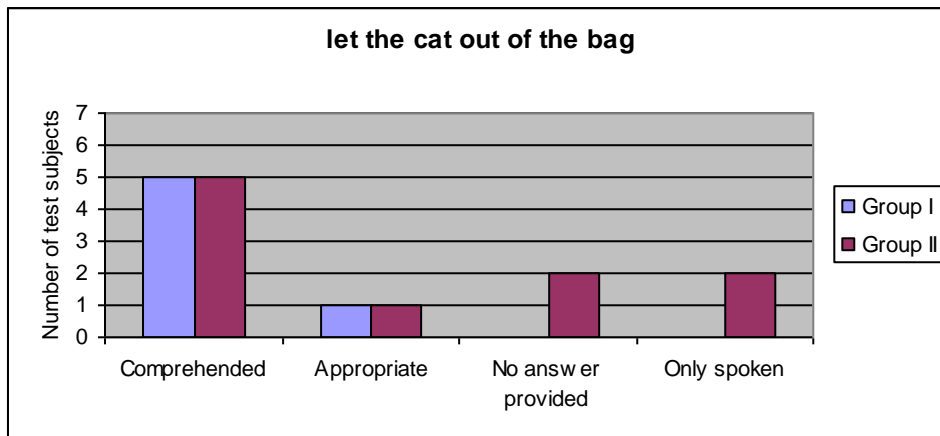

The high number of idiom comprehension implies that these idioms have constituents that carry independent meaning. This meaning must be present for lexical substitution to be possible in order to ensure similar function and meaning in the substituting constituent. Otherwise, idiomatic meaning would require all original constituents to be present.

5.3 Concluding remarks

The purpose of this pilot study was to gather information concerning idioms in various constructions, to test the comprehension of these and make suggestions for a design for a larger survey. It is important to take into consideration that this was a small scale investigation, thus the responses of each test subject had more of an influence on the overall results than they would have in a larger experiment. The overall results from this study showed that a great number of idioms were comprehended in various constructions in sentences. However, results from the evaluation of appropriateness were more uncertain and therefore less convenient for making claims about the flexibility of idioms.

Modification and quantification are operations that involve minor changes in the structure of the idiom. Because constituents are still in the vicinity of each other, the original form of the idiom is easily perceived. Quantified idioms were more consistently paraphrased as such, than modified idioms. Some test subjects did paraphrase modified idioms sentences so that the modifier clearly affected one part of the idiom. However, this seemed not to be a consideration subjects followed consistently. Internal semantic structure of idioms on the basis of modification in this survey was thus not convincing.

The transformation tested in this survey demonstrated less cases of idiomatic interpretation by test subjects. Passivization of idioms in sentences means intrusive changes to the structure of the expression, which makes the idiom more difficult to recognize. This transformation requires that the interpreter is able to associate non-adjacent constituents with each other to be able to reach the idiomatic interpretation (cf. chapter 3.3). Otherwise interpretation could result in literal meaning if such a reading is possible, e.g. as with the passivized version of *cross det.bridge*.

Most of the cases with passivization in the survey had a meaning that corresponded to a transitive action. In this sense, the literal interpretation is of significance. As pointed out by Langlotz (2006), idioms that have a literal counterpart with a transitive verb, are more amenable to passivization (cf. 4.2). Results from the study corroborate Langlotz's assumption. All idioms that had such a possible literal counterpart were comprehended to great extent as opposed to the noncompositional idiom *shoot the breeze* which yielded an idiomatic interpretation only in a few cases when passivized. The noncompositional idiom *saw logs* also had a possible literal reading, but received low results of idiom comprehension.

Lexical substitution does not involve the rearranging of constituents. However a major change occurs when a part of the idiom is replaced by some other element. Despite this, the survey showed that the meaning of the idiom was still accessible to test subjects since the replacement constituent had the same syntactic and semantic function. The replacement of these constituents must indicate that they carry independent meaning. Otherwise, the idiom would not be discerned. The high percentage of idiom comprehension of the cases with lexical substitution implies that these idioms in fact have internal structure.

As mentioned, most test subjects recognized many idioms. Despite divided opinions between the groups, there were no astounding results with respect to the appropriateness of any given idiom that supported or contradicted my hypothesis. Based on this observation I assume that many transformed idioms will be accepted, at least in spoken discourse. For further research it would be interesting to incorporate these idioms into larger stretches of discourse. Idioms in context are less marked and will perhaps seem more suitable. It would be interesting to discover whether or not there are any differences in the evaluation of discourse-embedded idioms and relatively isolated single-sentence idioms, such as those investigated here. One could expect that percentages for both comprehension and appropriateness would be higher in cases with context.

Another observation made in this study was that the subjects in Group II were more ready to accept idioms in various forms than subjects in Group I. Group II consisted of non-

native speakers of English that were of a younger age group than the native speakers in Group I. My initial response to these results is that it occurred due to the difference between native and non-native speakers. Native speakers will be more averse to accept sentences and utterances that are unusual or seem awkward. Non-native speakers on the other hand, might be more focused on understanding the meaning of the sentence. Though awkward in composition, a sentence that makes sense and is grammatically correct is therefore perhaps perceived as appropriate. However, the divergent opinions could also be because the groups represented different generations. This would be interesting to investigate further, in which case it would be useful to test these types of structures on groups of native speakers of different generations.

An interesting case of modification was the example with the noncompositional idiom *kick the bucket*. Results from this sentence countered my assumption that transformed noncompositional idioms would not be comprehended. The result could indicate that familiar idioms can be productive and amenable to change. The more familiar an idiom is, the more integrated in language it is and the more readily it can be used in various syntactic structures. In this case, these idioms show a high degree of idiomaticity (cf. chapter 2).

The similarities in idiom comprehension noticed among test subjects could also pertain to familiarity and degree of idiomaticity. This could indicate that some idioms are more flexible than others. The fact that the majority of the non-native speakers were not familiar with particular idioms had a major impact on results. This would have to be tested on native speakers or with idioms that are known to all test subjects. Therefore, the familiarity of the idioms should be evaluated in advance in such an investigation. Idiomatic interpretation requires language knowledge. The function of the transformed idiom is still recognized. Thus, the more familiar the idiom is, the more easily it will be recognized which means that more familiar idioms could be more productive. In a larger experiment, I would also include familiar noncompositional idioms such as *kick the bucket* in other types of constructions with literal counterparts. The lack of an alternative literal reading of the sentence in this survey makes the question of the flexibility of this idiom uncertain. It might be that this idiom is very familiar which is why it is comprehended to such great extent, however a literal counterpart would perhaps produce different results that demonstrate that noncompositional idioms cannot be altered.

Results from this study imply that many idioms do in fact retain their meaning in many different syntactic structures. However, the answer to the question of how we comprehend them still seems somewhat elusive. There are probably many factors that induce

idiomatic meaning, e.g. frequency of use, conventionality, context or discourse function. Syntactic and semantic meaning alone cannot explain why the idiomatic interpretation is preferred in many cases (cf. chapter 3.1). The fact that they have an internal structure certainly helps explain the motivation interpretation and for association of idiomatic constituents. However, this association occurs from some kind of conceptual structures based on conventional knowledge of language (cf. chapter 2.1).

The high percentage of idiom comprehension attested in my survey indicates that many idioms are flexible, and can appear in many constructions without losing their idiomaticity. These results suggest that certain idioms are strongly integrated in language and that they have internal semantic structure. I maintain that results from this study provide evidence for the claim that idiom constituents carry meaning which infers that these idioms have internal semantic structure.

6. Conclusion

The aim of my thesis was to explore some of the problems constituted by idioms, notably those related to their form and behavior. In chapter 2 I provided an introduction to the overall topic and discussed some of the definitions of ‘idiom’ that have been suggested in the relevant literature. I have shown that a sufficient description is elusive, because the variant behavior of idioms presents exceptions to every rule. Not even the widely assumed notion that idioms are noncompositional is indisputable. My contribution to the issue of describing idioms has been to explain them within theories of categorization, as discussed in chapter 2. The traditional notion of a category falls short when it comes to idioms, since the classical theory requires strict boundaries between categories and members with identical features. Idioms are not equivalent members of a category because they display variant features. Nonetheless, they are still considered and categorized as such in linguistic theory. I showed that Prototype Theory offers a suitable framework for discussing the categorizing of idioms, as it focuses on familiarity and prototypes rather than clear-cut boundaries and for the members of any given category not to display identical features.

In chapter 3, the focus was on the mental representation of idioms as lexical items. I briefly discussed Chomsky’s lexical insertion in relation to words and collocations that are dominated by one syntactic category, i.e. elements that have no internal structure and thus are noncompositional. This thesis advocates the existence of compositional idioms with internal semantic structures, which is evidenced by their syntactic flexibility. This relates to how categories have variant members and fuzzy boundaries (cf. chapter 2.2) e.g. the idiom category. Therefore I argue that Chomsky’s approach to idioms in terms of lexical insertion is insufficient. Flexible idioms pose a challenge for lexical representation in distinguishing between literal and idiomatic interpretation. Following Jackendoff, I argued that our recognizing and analyzing an idiom is dependent on cognitive abilities that are best accounted for in terms of lexical licensing in the framework *Representation Modularity* (cf. Jackendoff). In accordance with Tversky and Hemenway (cf. chapter 2.2), lexical licensing infers that lexical items are understood as part-whole structures in the sense that the approach presents separate but correlated phonologic, syntactic and conceptual structures in an analysis. This type of analysis makes it possible to distinguish between literal and idiomatic interpretation also with transformed idioms. Thus the approach can account for the syntactic flexibility of

idioms. The lexical representation of idioms is not straightforward as certain idioms can be argued to be compositional and have internal semantic structure.

In chapter 4 I argued that certain idioms are amenable to syntactic operations, such as modification, quantification, passivization, topicalization and lexical substitution, all of which are applicable only to meaningful constituents. It is shown in detail that certain idioms can appear in such constructions without losing their idiomatic interpretation, thus these idioms must have meaningful parts. From this follows that certain idioms have internal semantic structure. With modification and quantification the change made to the idiom applies only to a constituent part of the idiom. This indicates that these constituents carry semantic weight.

To transform a phrase into passive voice requires that the verb corresponds to a transitive action. Many compositional idioms display this correspondence which means they behave more similarly to literal phrases than the noncompositional idioms which do not correspond to a transitive action. Passivization of an idiom involves change in position of constituent parts which requires that they carry meaning. Topicalization and subject control can also serve as evidence for this claim. It makes no sense to bring meaningless constituents into focus, thus the possibility for idiom parts to be topicalized imply they have meaning. Subject control has been applied as a counterargument to this, because very few idioms can undergo this transformation. The agent in such a construction is always volitional and idiomatic constituents rarely are. This type of transformation does not necessarily disprove that idiom parts can carry meaning, it merely highlights the fact that idioms do not behave exactly like literal phrases.

It was shown with lexical substitution how some idioms have constituents that can be replaced. These constituents hold meanings that can be replaced by others that function similarly to the original constituent and represent the same conceptual idea. These operations give evidence to the fact that some idioms have internal semantic structure and that these structures are syntactically restricted according to conceptual correspondences as shown with lexical licensing.

To test the predictions made in chapter 4, I conducted a pilot study in which various idioms were tested for comprehension and appropriateness in some of these constructions. The results from this study corroborate the claim that certain idioms are comprehended in various constructions. Even a modified version of the (prototypically) noncompositional idiom *kick the bucket*, received a high degree of comprehension results. In chapter 2 I presented this as a prototypical example of the idiom category. Therefore, this could indicate that familiarity or degree of idiomaticity is of significance to the flexible disposition of

idioms. In a future analysis it would be interesting to investigate the significance of familiarity and frequency of use i.e. the degree of idiomaticity with respect to idiom flexibility.

The evaluations of appropriateness were divided among test subjects and thus did not strongly support idiomatic flexibility. However the results did not disprove flexibility either. I find the results interesting because they indicate involvement of conceptual structures. Prototype Theory proves helpful in explaining how idioms are comprehended despite their different structures. Similar to recognizing a physical object, the cognitive abilities of people perhaps play a part in recognizing the parts of the idiom and associating these meanings to the whole expression. Lexical licensing describes the capacities of these associations by formally representing them in analyses as correspondences.

It is useful to acknowledge that to grasp the notion, structure and behavior of 'idioms' as well as representing them formally, to some extent relies on conceptual structures. Cognitive linguistics and generative grammar both deliver beneficial contributions to the issue and thus idioms can have the best of both worlds.

Bibliography

Ammer, C. (1997). *The American Heritage Dictionary of Idioms*. Boston: Houghton Mifflin Company.

Arnold, D. Sadler, L. (1989). 'Non-compositionality and Translation'. In Peckham, J. (ed). *Recent Developments and Applications of Natural Language Processing*. London: Kogan Page, pp. 23-55.

Bloomfield, L. (1933). *Language*. Chicago/London: University of Chicago Press

Burger, H. (1973). *Idiomatik des Deutschen*. Tübingen: Niemeyer.

Cacciari, C. Tabossi, P. (1988). 'The Comprehension of Idioms'. In *Journal of Memory and Language*, Vol. 27, pp. 668-683.

Cacciari, C. Tabossi, P. (eds.) (1993). *Idiom Comprehension in Idioms. Processing, Structure and Interpretation*. New Jersey/London: Lawrence Erlbaum Associates Inc.

Chafe, W. L. (1968). 'Idiomaticity as an Anomaly in the Chomskyan Paradigm'. In *Foundations of Language*, Vol. 4, No. 2, pp. 109-127.

Chomsky, N. (1965). *Aspects of the Theory of Syntax*. USA: The Massachusetts Institute of Technology.

Chomsky, N. (1980). *Rules and Representations*. Oxford: Basil Blackwell Publisher Ltd.

Croft, W. Cruse, D. A. (2004). *Cognitive Linguistics*. Cambridge: Cambridge University Press.

Ernst, T. (1981). 'Grist for the Linguistic Mill: Idioms and "Extra" Adjectives'. In *Journal of Linguistic Research*, Vol. 1, pp. 51-68.

- Everaert, M. Linden, E. van der, Schenk, A., Schreuder. R. (eds.) (1995). *Idioms: Structural and Psychological Perspectives*. New Jersey: Lawrence Erlbaum Associates.
- Fleischer, W. (1982). *Phraseologie der deutschen Gegenwartssprache*. Leipzig: VEB Verlag Enzyklopädie.
- Fraser, B. (1970). 'Idioms within a Transformational Grammar'. In *Foundations of Language*, Vol. 6, No. 1, pp. 22-42.
- Freidin. R. (1992). *Foundations of Generative Syntax*. USA: MIT Press
- Dobrovolskij, D. (1997). *Idiome im mentalen Lexikon: Ziele und Methoden der kognitivbasierten Phraseologieforschung*. Trier: Wissenschaftlicher Verlag
- Gazdar, G., Klein, E., Pullum, G., Sag, I. (1985). *Generalised Phrase Structure Grammar*. Cambridge, Massachusetts: Harvard University Press.
- Gestel, F. van (1995). 'En Bloc Insertion'. In Everaert, M. Linden, E. van der, Schenk, A., Schreuder. R. (eds.). *Idioms: Structural and Psychological Perspectives*. New Jersey: Lawrence Erlbaum Associates, pp. 75-96.
- Healey, A. (1968). 'English Idioms'. In *Kivung*, Vol. 1, No.2, pp. 71-108.
- Hockett, C. (1958). *A Course in Modern Linguistics*. New York: The Macmillan Company,
- Jackendoff, R. (1997). *The Architecture of the Language Faculty*. USA: Massachusetts Institute of Technology.
- Katz, J. J. Postal, P. M. (1963). 'Semantic Interpretation of Idioms and Sentences Containing Them'. In *Quarterly Progress Report*, Vol. 70, pp. 275-82.
- Kavka, S. Zybert, J. (2004). 'Glimpses on the History of Idiomaticity Issues'. In Štekauer, P. (ed.). *Journal of the Theoretical Linguistics*. Vol. 1, No. 1, pp. 54-66.

- Langlotz, A. (2006). *Idiomatic Creativity*. Amsterdam/Philadelphia: John Benjamins Publishing Company.
- Lakoff, G. (1987). *Women, Fire and Dangerous Things. What categories Reveal about the Mind*. Chicago/London: The University of Chicago Press.
- Lakoff, G. Johnson, M. (1980). *Metaphors We Live By*. Chicago/London: The University of Chicago Press.
- Linden, E. van der (1993). *A Categorical, Computational Theory of Idioms*. Utrecht: LED
- Makkai, A. (1972). *Idiom Structure in English*. The Hague/Paris: Mouton & co.
- Malkiel, Y. (1959). 'Studies in Irreversible Binomials'. In *Lingua: International Review of General Linguistics Revue Internationale de Linguistique Générale*. Vol. VIII, No. 2. Amsterdam: North-Holland Publishing Company, pp. 113-160.
- Margolis, E. Laurence, S. (1999). *Concepts: core readings*. USA: MIT Press
- Nicolas, T. (1995). 'Semantics of Idiom Modification'. In Everaert, M. Linden, E. van der, Schenk, A., Schreuder, R. (eds.). *Idioms: Structural and Psychological Perspectives*. New Jersey: Lawrence Erlbaum Associates, pp. 233-252.
- Nunberg, Geoffrey. Sag, Ivan A. Wasow, Thomas. (1994). 'Idioms'. In *Language*, Vol. 70, No. 3, pp. 491-538.
- Onysko, A. Michel, M. (eds.) (2010). 'Introduction: Unravelling the cognitive in word formation'. In Onysko, A. Michel, M. (eds.). *Cognitive Perspectives on Word Formation*. Berlin/New York: De Gruyter Mouton, pp. 1-28.
- Pulman, S. (1993). 'The Recognition and Interpretation of Idioms'. In Cacciari, C., Tabossi, P. (eds.). *Idiom Comprehension in Idioms. Processing, Structure and Interpretation*. New Jersey/London: Lawrence Erlbaum Associates Inc., pp. 249-270.

- Radford, A. (1997). *Syntax: A Minimalist Introduction*. UK: Cambridge University Press.
- Schenk, A. (1995). 'The Syntactic Behaviour of Idioms'. In Everaert, M. Linden, E. van der, Schenk, A., Schreuder, R. (eds.). *Idioms: Structural and Psychological Perspectives*. New Jersey: Lawrence Erlbaum Associates, pp. 253-271.
- Stock, O. Slack, J. Ortony, A. (1993). 'Building Castles in the Air. Some Computational and Theoretical Issues'. In Cacciari, C., Tabossi, P. (eds.). *Idiom Comprehension in Idioms. Processing, Structure and Interpretation*. New Jersey/London: Lawrence Erlbaum Associates Inc., pp. 229-247.
- Strässler, J. (1982). *Idioms in English: A Pragmatic Analysis*. Tübingen: Gunter Narr Verlag.
- Sweet, H. (1899). *The Practical Study of Languages*. London: J. M. Dent & Co.
- Taylor, J. R. (1995²). *Linguistic Categorization*. Oxford: Clarendon Press.
- Tversky, B. Hemenway K. (1984). 'Objects, Parts and Categories'. In *Journal of Experimental Psychology: General*. Vol. 113, pp. 169-93.
- Vegge, T. (2011). *An Idiom Paints A Thousand Words*. Kristiansand: (unpublished paper) University of Agder.
- Verhagen, M. (1990). 'Support Verbs in Disneyland'. In *Eurotra-Essex Internal Memoranda* No. 20. Wivenhoe: Essex University Linguistics Department.
- Vitto, C. L. (2003²). *Grammar by Diagram: Understanding English Grammar through Traditional Sentence Diagraming*. Canada: Broadview Press Limited.
- Wasow, T. Sag, I.A. Nunberg, G. (1980). 'Idioms: An Interim Report'. In *Preprints of the XIIIth International Congress of Linguists*. Tokyo: Nippon Toshi Center, pp. 87-96.
- Weinreich, U. (1969). 'Problems in The Analysis of Idioms'. In Puhvel, J. (ed.). *Substance and Structure of Language*. California: University of California Press, pp. 23-82.

Wittgenstein, L. (1967³) *Philosophical Investigations*. (translated by Anscombe, G.E.M.)
Oxford: Blackwell Publishers.

Zeller, J. (2001). *Particle Verbs and Local Domains*. Amsterdam/Philadelphia: John
Benjamins Publishing Company.

Survey application used in the pilot study:

Lime Survey: the open source survey application.

<http://www.limesurvey.org/>

Appendix 1

Questionnaire

1. The hatchet was buried and peace restored to the home.

	How appropriate do you consider this sentence to be? Equally appropriate in written and spoken language <input type="checkbox"/> Equally inappropriate in written and spoken language <input type="checkbox"/> Only appropriate in spoken language <input type="checkbox"/>
--	--

2. Those plans dropped like plastic ninepins.

	How appropriate do you consider this sentence to be? Equally appropriate in written and spoken language <input type="checkbox"/> Equally inappropriate in written and spoken language <input type="checkbox"/> Only appropriate in spoken language <input type="checkbox"/>
--	--

3. Tabs were kept on Mary by the police

	How appropriate do you consider this sentence to be? Equally appropriate in written and spoken language <input type="checkbox"/> Equally inappropriate in written and spoken language <input type="checkbox"/> Only appropriate in spoken language <input type="checkbox"/>
--	--

4. Jerry and Maria buried the big hatchet

	How appropriate do you consider this sentence to be? Equally appropriate in written and spoken language <input type="checkbox"/> Equally inappropriate in written and spoken language <input type="checkbox"/>
--	--

	Only appropriate in spoken language <input type="checkbox"/>
--	--

5. The bridge was crossed easily

	How appropriate do you consider this sentence to be? Equally appropriate in written and spoken language <input type="checkbox"/> Equally inappropriate in written and spoken language <input type="checkbox"/> Only appropriate in spoken language <input type="checkbox"/>
--	--

6. Logs were sawn by John last night

	How appropriate do you consider this sentence to be? Equally appropriate in written and spoken language <input type="checkbox"/> Equally inappropriate in written and spoken language <input type="checkbox"/> Only appropriate in spoken language <input type="checkbox"/>
--	--

7. Eric suggested they bury the axe to make peace

	How appropriate do you consider this sentence to be? Equally appropriate in written and spoken language <input type="checkbox"/> Equally inappropriate in written and spoken language <input type="checkbox"/> Only appropriate in spoken language <input type="checkbox"/>
--	--

8. Unfortunately, Frannie let the unbelievably big cat out of the bag at the party

	How appropriate do you consider this sentence to be? Equally appropriate in written and spoken language <input type="checkbox"/> Equally inappropriate in written and spoken language <input type="checkbox"/> Only appropriate in spoken language <input type="checkbox"/>
--	--

9. Nina had thrown in many towels in her lifetime

	How appropriate do you consider this sentence to be? Equally appropriate in written and spoken language <input type="checkbox"/> Equally inappropriate in written and spoken language <input type="checkbox"/> Only appropriate in spoken language <input type="checkbox"/>
--	--

10. Grandpa John finally kicked the long overdue bucket

	How appropriate do you consider this sentence to be? Equally appropriate in written and spoken language <input type="checkbox"/> Equally inappropriate in written and spoken language <input type="checkbox"/> Only appropriate in spoken language <input type="checkbox"/>
--	--

11. Frank told a joke and cracked the ice

	How appropriate do you consider this sentence to be? Equally appropriate in written and spoken language <input type="checkbox"/> Equally inappropriate in written and spoken language <input type="checkbox"/> Only appropriate in spoken language <input type="checkbox"/>
--	--

12. John and Mary were discussing all the bridges they had crossed in their lives

	How appropriate do you consider this sentence to be? Equally appropriate in written and spoken language <input type="checkbox"/> Equally inappropriate in written and spoken language <input type="checkbox"/> Only appropriate in spoken language <input type="checkbox"/>
--	--

13. Marion recognized the magnitude of the problem and found it best to let those sleeping dragons lie

	How appropriate do you consider this sentence to be? Equally appropriate in written and spoken language <input type="checkbox"/> Equally inappropriate in written and spoken language <input type="checkbox"/> Only appropriate in spoken language <input type="checkbox"/>
--	--

14. Tongues were bitten throughout the meal

	How appropriate do you consider this sentence to be? Equally appropriate in written and spoken language <input type="checkbox"/> Equally inappropriate in written and spoken language <input type="checkbox"/> Only appropriate in spoken language <input type="checkbox"/>
--	--

15. When Henry started dancing the ice was broken

	How appropriate do you consider this sentence to be? Equally appropriate in written and spoken language <input type="checkbox"/> Equally inappropriate in written and spoken language <input type="checkbox"/> Only appropriate in spoken language <input type="checkbox"/>
--	--

16. The couple had many hatchets to bury between them

	How appropriate do you consider this sentence to be? Equally appropriate in written and spoken language <input type="checkbox"/> Equally inappropriate in written and spoken language <input type="checkbox"/> Only appropriate in spoken language <input type="checkbox"/>
--	--

17. It was as if Jamie had let a horse out of a bag

	How appropriate do you consider this sentence to be? Equally appropriate in written and spoken language <input type="checkbox"/> Equally inappropriate in written and spoken language <input type="checkbox"/> Only appropriate in spoken language <input type="checkbox"/>
--	--

18. The breeze was shot when Sally and Peter had coffee

	How appropriate do you consider this sentence to be? Equally appropriate in written and spoken language <input type="checkbox"/> Equally inappropriate in written and spoken language <input type="checkbox"/> Only appropriate in spoken language <input type="checkbox"/>
--	--

19. The hatchet was not buried between Frank and Alice as planned

	How appropriate do you consider this sentence to be? Equally appropriate in written and spoken language <input type="checkbox"/> Equally inappropriate in written and spoken language <input type="checkbox"/> Only appropriate in spoken language <input type="checkbox"/>
--	--

20. John had many important colors he felt a need to nail to the mast

	How appropriate do you consider this sentence to be? Equally appropriate in written and spoken language <input type="checkbox"/> Equally inappropriate in written and spoken language <input type="checkbox"/> Only appropriate in spoken language <input type="checkbox"/>
--	--