

October 2018

## Creating a Symbol of Science: The Development of a Standard Periodic Table of the Elements

Ann Robinson

Follow this and additional works at: [https://scholarworks.umass.edu/dissertations\\_2](https://scholarworks.umass.edu/dissertations_2)



Part of the [History of Science, Technology, and Medicine Commons](#)

---

### Recommended Citation

Robinson, Ann, "Creating a Symbol of Science: The Development of a Standard Periodic Table of the Elements" (2018). *Doctoral Dissertations*. 1385.

[https://scholarworks.umass.edu/dissertations\\_2/1385](https://scholarworks.umass.edu/dissertations_2/1385)

This Open Access Dissertation is brought to you for free and open access by the Dissertations and Theses at ScholarWorks@UMass Amherst. It has been accepted for inclusion in Doctoral Dissertations by an authorized administrator of ScholarWorks@UMass Amherst. For more information, please contact [scholarworks@library.umass.edu](mailto:scholarworks@library.umass.edu).

**CREATING A SYMBOL OF SCIENCE: THE DEVELOPMENT OF A STANDARD  
PERIODIC TABLE OF THE ELEMENTS**

A Dissertation Presented

by

ANN E. ROBINSON

Submitted to the Graduate School of the  
University of Massachusetts Amherst in partial fulfillment  
of the requirements for the degree of

DOCTOR OF PHILOSOPHY

September 2018

Department of History

© Copyright by Ann E. Robinson 2018

All Rights Reserved

**CREATING A SYMBOL OF SCIENCE: THE DEVELOPMENT OF A STANDARD  
PERIODIC TABLE OF THE ELEMENTS**

A Dissertation Presented

by

ANN E. ROBINSON

Approved as to style and content by:

---

John W. Servos, Chair

---

Emily T. H. Redman, Member

---

Sigrid Schmalzer, Member

---

Jeffry L. Ramsey, Member

---

Brian W. Ogilvie, Department Head  
Department of History

## **DEDICATION**

To the Grossman Library for University Extension.  
Much of this dissertation was written within your walls and it was finished just as  
you closed.

## ACKNOWLEDGMENTS

Friends and family are what make everything possible. My parents were a little taken aback when I decided to quit my job and go back to grad school full-time but they did everything in their power to support me while I did it. My sister, Maria, who also seems to be following a meandering path between careers and education, has provided commiseration as well as support from her perch in far off Vancouver. Mary Frances Angelini has been with me through the whole thing, listening to complaints, asking questions, providing distraction in many forms, prodding me to work, and otherwise being supportive. My cat, Harley, has tolerated moving three times in five years with mostly good grace and only a little bloodshed and still continues to give unconditional love and support of the furry variety.

Graduate students can't make it through graduate school without the help of other graduate students. I was extremely fortunate to share an office during my first year at UMass with Andrew Dausch and Chris Fobare. During that first and often trying year, they dispensed advice, answered questions, and otherwise helped me make it through. Although no longer being together on campus, they have continued to provide advice, comments, and suggestions – and a willing ear – both virtually and in person. Amy Fisher, now an alum of the University of Minnesota and faculty at the University of Puget Sound, has been my History of Science Society roommate for several years and has offered encouragement and a sounding board, as well as pointing me in a very promising research direction through her own research.

Graduate students also can't make it through graduate school without the help of faculty. John Servos, my advisor and committee chair, was willing to take me on practically sight unseen, and has helped me further navigate the waters of the history of science, while continually offering support and patience, as well as advice. Larry Owens has been my unfailing supporter at UMass and, although now retired, has remained enthusiastic about my work. Emily Redman provided deadlines when asked, attempted to lure me into public history with several summer jobs, and has otherwise been a helpful guide. Sigrid Schmalzer and Jeff Ramsey offered insightful comments that only made the final product better. An enthusiastic and grateful "Thank you!" to them all.

A historian can't do her work without libraries, archives, and museums. As a librarian, I have an extra special place in my heart for them. Top billing in my list of thanks goes to the UMass Interlibrary Loan department (OCLC symbol AUM) who does an amazing job at filling requests in a speedy fashion and does not blink in the face of odd requests. Sharing top billing is the staff at the Five Colleges Depository, aka The Bunker, who filled countless requests for articles from 19<sup>th</sup> and early 20<sup>th</sup> century scientific journals and who were most helpful and understanding when the citations I gave them sometimes weren't completely accurate. Colleagues in the Harvard Library, especially Reed Lowrie and Mary Frances Angelini, provided assistance in locating citations, answering questions, and providing access to materials, and Philip Gerstein remains my go-to person for all questions Russian. Amy Tims, American Antiquarian Association, put me in touch with her former colleagues at the Lilly Library, Indiana University Bloomington, for assistance in

obtaining a copy of a rare pamphlet. Andrew Mangravite and Patrick Sharp, Chemical Heritage Foundation, are both extremely knowledgeable about their archival collections and enthusiastic about sharing that knowledge. Kathleen Imrie at the Ontario Institute for Studies in Education, University of Toronto, was accommodating in providing access to the Ontario Textbook Collection. Edward Copenhagen in Special Collections, Gutman Library, School of Education, Harvard University, was extremely helpful when I turned up in his reading room without advanced warning to look at the Historical Textbooks Collection. Deborah Douglas, Director of Collections & Curator of Science and Technology at the MIT Museum, sent me on the hunt for photographs of periodic tables in classrooms. My research has also led me wonderful interactions with the staffs of the Niels Bohr Library & Archives, American Institute of Physics; Medical History Library, Harvey Cushing/John Hay Whitney Medical Library, and Manuscripts and Archives, Yale University; National Archives and Records Administration–Pacific Region; Manuscript Reading Room, Library of Congress; and the Manuscript Reading Room, Library and Archives Canada.

I was extremely fortunate to spend the 2012-2013 academic year as a Dissertation Writing Fellow at the Philadelphia Area Center for the History of Science (now the Consortium for History of Science, Technology, and Medicine). My time at PACHS was invaluable for beginning the writing process. Participating in working groups, attending PACHS events, as well as the multitude of history of science events in the Philadelphia area, provided a wonderful opportunity to immerse myself in the history of science and to meet graduate students, faculty,



librarians, and archivists. Access to the libraries and their collections at the University of Pennsylvania yielded previously unknown treasures. I thank Babak Ashafri for the opportunity to be a PACHS Fellow, and the rest of the PACHS staff for their help. I was also fortunate to spend one month as a Herdegen Fellow at the Chemical Heritage Foundation (now the Science History Institute), just down the street from PACHS. Carin Berkowitz made a concerted effort to include me in CHF events while I was at PACHS and I was able to take advantage of the CHF Fellows writing group throughout the year. This dissertation has only been improved by my time at PACHS and CHF. An early version of Chapter 2 was the subject of a meeting of the PACHS Physical Sciences Working Group and a portion of it was presented as a CHF Brown Bag Lecture. I thank the members of all those groups for their comments, questions, and suggestions. A portion of Chapter 4 formed a paper given at the Third Biennial Early-Career Conference for Historians of the Physical Sciences, held in 2016; I thank Audra Wolfe and the audience for their comments.

Finally, this dissertation would be about something completely different if it weren't for Heather Cox Richardson. When I presented her with my project idea for her Writing History seminar, she said, "This would make a great dissertation topic." I think she was right.

## ABSTRACT

### CREATING A SYMBOL OF SCIENCE: THE DEVELOPMENT OF A STANDARD PERIODIC TABLE OF THE ELEMENTS

SEPTEMBER 2018

ANN E. ROBINSON, B.A., UNIVERSITY OF CALIFORNIA SAN DIEGO

A.L.M., HARVARD UNIVERSITY EXTENSION SCHOOL

Ph.D., UNIVERSITY OF MASSACHUSETTS AMHERST

Directed by: Professor John W. Servos

It is probably a surprise to most people that the periodic table they remember from high school chemistry is not the only periodic table – and never has been. Currently there are probably over a thousand different forms. The table in your chemistry textbook or on the wall chart in your chemistry classroom is not *the* periodic table. It is simply the most commonly used form. In fact, the International Union of Pure and Applied Chemistry (IUPAC), the international standards-making body for chemistry, has stated that although they encourage the use of this form, they will not endorse any one form of the periodic table as *the* periodic table. So where did this form come from? How did it come to be the current standard form of the periodic table? Most writing on the periodic table does not address such questions. For what is widely regarded as an icon of science, little is actually known about the origin of its form.

This dissertation aims to answer the questions of how the current standard form of the periodic table was developed and how it came to be ubiquitous in classrooms and textbooks. In it, I highlight the practical nature of chemistry, which influenced not only the development and acceptance of the periodic law but the

creation of graphical representations of the periodic system that placed an emphasis on utility rather than art. I examine the role of research and pedagogy in the development of classification schemes for the elements, particularly the periodic system. I argue that the role played by pedagogy was more influential than that of research in the creation of new classification systems and the multiplicity of graphical representations of the periodic law. In the case of the periodic table, research-down theories about pedagogy, in which textbooks are seen merely as codifications of accepted scientific knowledge, do not hold true.

## TABLE OF CONTENTS

	Page
ACKNOWLEDGMENTS .....	v
ABSTRACT.....	ix
LIST OF FIGURES .....	xiii
CHAPTER	
1. INTRODUCTION: THE PERIODIC TABLE OF THE ELEMENTS.....	1
Introduction .....	1
The Periodic Table and Its Histories.....	3
A Standard Form of the Periodic Table.....	14
Chemical Education and the Periodic Table.....	19
Research Choices .....	25
2. “GENERALISATIONS AND ESTABLISHED FACTS”: ORGANIZING THE ELEMENTS BEFORE 1869 .....	37
Introduction.....	37
Elements and Atomic Weight .....	40
Prout’s Hypothesis and the Unity of Matter .....	43
Mathematical Relationships Between the Elements .....	50
Visualizing Elemental Relationships.....	58
Chemical Education and the Organization of the Elements.....	71
3. THE SO-CALLED ELEMENTS: THE PERIODIC LAW, THE ELEMENTS, AND THE UNITY OF MATTER, 1869-1900.....	84
Introduction .....	84
The Discovery of the Periodic Law.....	86
Problems Elemental .....	95
The Discovery of Gallium and Scandium.....	96
The Atomic Weight of Beryllium.....	104
The Unity of Matter.....	110
The Problem With Elements .....	111
Prout Revived .....	114
Visual Representations of the Periodic Law.....	120

Pedagogy and the Periodic System .....	131
The Surprising Elements.....	145
4. “THE OLD AND THE NEW”: THE PERIODIC LAW IN THE ERA OF RADIOACTIVITY, 1896-1914 .....	154
Introduction .....	154
Chemists and the Electron .....	158
Radioactivity and the Radioelements.....	164
The Problem of Radium.....	170
The Periodic System in Disarray?.....	187
1913 and All That.....	197
Not the Place for Variety: The Periodic System for Pedagogical Purposes.....	204
5. “THE FINGER-POST OF CHEMICAL SCIENCE”: THE PERIODIC LAW IN THE ERA OF INTERNATIONAL STANDARDIZATION, 1900-1923 AND BEYOND .....	216
Introduction .....	216
International Standards Before World War I.....	219
The International Union of Pure and Applied Chemistry .....	225
The Commission on Atomic Weights .....	227
The Conception of the Chemical Element.....	233
IUPAC and the Periodic Table.....	245
Pedagogy and the Standard Periodic Table .....	247
Deming’s Table .....	258
The CNIC and the Periodic Table, Redux.....	263
The Death of the Short Form Table?.....	269
The Standard Periodic Table of the Elements .....	275
6. CONCLUSION: THE “DYNAMIC AND CHANGING” PERIODIC TABLE .....	282
The Current Standard Form of the Periodic Table.....	282
Areas for Further Research .....	286
BIBLIOGRAPHY.....	289

## LIST OF FIGURES

Figure	Page
2.1: One of Kremer's Conjugated Triads (1858).....	53
2.2: Gmelin's Groups (1849) .....	54
2.3: Two of Cookes's Series (1855).....	56
2.4: Representation of Chancourtois's <i>vis tellurique</i> (1862) .....	62
2.5: Hinrichs's Spiral (1867) .....	64
2.6: Newlands's Table (1865).....	69
3.1: Meyer's 1864 Table .....	88
3.2: Meyer's 1868 Table .....	89
3.3: Mendeleev's 1869 Table.....	90
3.4: Meyer's 1870 Table .....	91
3.5: Meyer's Atomic Volume Curve.....	91
3.6: Mendeleev's 1870 Short Form Table.....	94
3.7: Mendeleev's 1871 Long Form Table .....	94
3.8: Table in <i>Fownes' Manual</i> (12th ed.).....	100
3.9: Mendeleev's 1879 Table .....	103
3.10: Wendt's Family Tree of the Elements (1891).....	118
3.11: Wilde's Table of Elementary Substances (1892).....	119
3.12: Baumhauer's Spiral (1870).....	124
3.13: Bayley's Table (1892).....	125
3.14: Bayley's Curve (1892) .....	126

3.15: Thomsen's Table (1895) .....	127
3.16: Stoney's Spiral (updated 1902 version) .....	128
3.17: Bassett's Table (1892).....	130
3.18: Rang's 1893 Table .....	131
3.19: Rang's 1895 Table .....	131
3.20: Shepard's Cylinder Table (1886).....	132
3.21: Reynold's Curve (1886).....	133
3.22: Spring's Curve (1887).....	134
3.23: Hinrichs's Spiral (1894) .....	135
3.24: Chemistry Classroom, University of Colorado at Boulder (1889) .....	137
3.25: Chemistry Lecture Theatre, University College of North Wales .....	139
3.26: Chemistry Room, Iowa State Normal School (1908).....	139
3.27: Venable's Table (1894).....	140
3.28: Errera's Table (1900) .....	150
4.1: Disintegration Series from Rutherford's <i>Radioactive Transformations</i> .....	184
4.2: Adams's 1911 Table .....	188
4.3: Cameron's 1909 Table .....	189
4.4: Radioelements in the Periodic System.....	193
4.5: Emerson's Helix Chemica .....	195
4.6: Werner's 1905 Table .....	210
4.7: Soddy's Figure of Eight .....	211
4.8: Bohr's Table .....	212
5.1: Bohr's Table (1922) .....	248

5.2: Sears's Table (1924) .....	249
5.3: Calcagni's version of Werner's table (1920) .....	251
5.4: Fajans's Table (1922) .....	252
5.5: Pfeiffer's Table (1920) .....	252
5.6: Harkins-Hall 3-D Table (1916) .....	254
5.7: Hildebrand's version of Soddy's Loop (1918) .....	256
5.8: Foster's Modern Table (1939) .....	257
5.9: Deming's Periodic Table (1923) .....	262
5.10: Von Richter's Table (1885) .....	264
5.11: Periodic Chart of the Atoms (1937) .....	270
5.12: Russian Periodic Table (1963) .....	271



**CHAPTER 1**  
**INTRODUCTION:**  
**THE PERIODIC TABLE OF THE ELEMENTS**

**Introduction**

The periodic table of the elements is one of the few things people remember from their high school chemistry classes. The number of “periodic tables” of things – beer, cheese, curse words, religions, professional cycling events, and just about anything you can think of – is evidence that it is remembered, if nothing else, as a way to organize something. Scientists also seem to have a fascination with the periodic table. In non-chemical fields, I have found periodic tables of genes, of black holes, of organizational behaviors, and of sexual identities, to name only a few. The Standard Model, the theory that describes three of the four fundamental forces in the universe, is often referred to as the periodic table of physics. It seems that other sciences want to have a periodic table of their own to organize sub-atomic particles, astronomical phenomena, behaviors, or whatever is in need of arranging.

Chemists themselves can't seem to stop creating new forms of the periodic table. What is probably a surprise to most people is that the periodic table they remember from high school chemistry is not the only periodic table – and never has been. Currently there are probably over a thousand different forms. The table in your chemistry textbook or on the wall chart in your chemistry classroom is not *the* periodic table. It is simply the most commonly used form. In fact, the International Union of Pure and Applied Chemistry (IUPAC), the international standards-making

body for chemistry, has stated that although they encourage the use of this form, they will not endorse any one form of the periodic table as *the* periodic table. So where did this form come from? How did it come to be the current standard form of the periodic table?

Most writing on the periodic table does not address such questions. Chemists are concerned with scientific explanations for the periodicity that underlies the periodic table, how far the periodic table might extend, and the best form for displaying relationships – chemical and physical – between the elements. Historians and philosophers of chemistry research the discovery of the periodic law and its precursors, the categorization of the many different forms of the table, and the relationship of physics to chemistry as seen through the table. Those who examine the many different graphical representations of the periodic table treat the current standard form no differently than other forms. Little mention is made of who might have created it, how it developed, or how it came to usurp all other forms. For what is widely regarded as an icon of science, little is actually known about the origin of its form.

This dissertation aims to answer the questions of how the current standard form of the periodic table was developed and how it came to be ubiquitous in classrooms and textbooks. In it, I highlight the practical nature of chemistry, which influenced not only the development and acceptance of the periodic law but the creation of graphical representations of the periodic system that placed an emphasis on utility rather than art. I examine the role of research and pedagogy in the development of classification schemes for the elements, particularly the periodic

system. I argue that the role played by pedagogy was more influential than that of research in the creation of new classification systems and the multiplicity of graphical representations of the periodic law. In the case of the periodic table, research-down theories about pedagogy, in which textbooks are seen merely as codifications of accepted scientific knowledge, do not hold true.

### **The Periodic Table and Its Histories**

The periodic table of the elements is the visual representation of two related concepts, the periodic law and the periodic system, which state respectively, there is a recurring pattern at regular intervals of properties of the elements and there are fundamental relationships among the elements. Each square on the table provides information about an element. The arrangement of the squares groups related elements together. The table thus quickly gives users information about a specific element or a group of elements. It acts as a tool, as a storehouse of knowledge, and as an *aide-mémoire*. These are among the important functions of tables. The periodic table of the elements is perhaps the most well-known chemical table, but it is far from the only one. Tables have long held an important place within chemistry, featuring heavily in both research and education since at least the early eighteenth century.

One of the earliest chemical tables, and perhaps the most well-known to historians of science, is that of French chemist Etienne-François Geoffroy. The *Table des différens rapports observés en Chymie entre différentes substances*, first published in 1718, is most commonly referred to as an affinity table as it displays the relationships between different substances and their ability to react with one

another, in other words their affinities, in a tabular form.<sup>1</sup> Geoffroy stated that it would be “useful” to make a table in which “one could see at a glance” the relationships between substances. He explained:

Through this table, those who begin to learn chemistry will quickly form an accurate idea of the relationship that the different substances have with each other, and chemists will find in the table an easy method for discovering what happens in several of their operations that are difficult to disentangle, and [for discovering] what should result from the mixtures that they make from different mixed bodies.<sup>2</sup>

The affinity table was a practical tool, useful in multiple situations and for multiple purposes.

Geoffroy’s affinity table spread across France and then across Europe. As there were multiple versions of the affinity theory, chemists created their own tables for use in research and in teaching. As historian Georgette Taylor has shown, British chemists such as William Cullen and Joseph Black established affinity theories at the of heart eighteenth century British chemistry through their teaching. As pedagogical tools, affinity tables served in assisting the dispersal of affinity theory as the students of Cullen and Black moved throughout Britain.<sup>3</sup> As historian Benjamin Cohen asserted in his study of pre-periodic tables, chemical tables “were

---

<sup>1</sup> Affinity was an important concept in eighteenth century chemistry. For more, see Mi Gyung Kim, *Affinity, That Elusive Dream: A Genealogy of the Chemical Revolution* (Cambridge, MA: MIT Press, 2003).

<sup>2</sup> Etienne-François Geoffroy, “Table of the Different Relations Observed in Chemistry Between Different Substances,” *Science in Context* 9 (1996): 314, translated by Andrew Mendelsohn in cooperation with Ursula Klein. Etienne-François Geoffroy, “Table des différens rapports observés en Chymie entre différentes substances,” *Mémoires de l’Académie Royale des Sciences* 1718: 203.

<sup>3</sup> Georgette Taylor, “Variations on a Theme: Patterns of Congruence and Divergence Among 18<sup>th</sup> Century Chemical Affinity Theories” (PhD diss., University College London, 2006).

never just stagnant repositories of facts, but also devices that were used by chemists for chemical order to be established.”<sup>4</sup>

Given the importance of tables – and the iconic nature of the periodic table – much has been written about the periodic table of the elements. Most of the histories have been written by chemists and are focused on the discovery of the periodic law, its acceptance, and the changes it has undergone since its discovery, as well as scientific explanations for the elasticity that has allowed the periodic table to continue as a useful tool despite major changes in the understanding of atoms and elements. Some of them discuss the variety of forms the periodic table has taken over the course of a century and a half. By and large, they are not very concerned with the origin, dispersion, and implementation of the current standard form of the table. There is also little discussion of the use of the periodic table in chemical education.

Coming a mere twenty-five years after its discovery, the earliest history of the periodic law, *The Development of the Periodic Law*, was written by the American chemist Francis Preston Venable in 1896.<sup>5</sup> Venable, a professor at the University of North Carolina, was a great proponent of the periodic law and urged its use in

---

<sup>4</sup> Benjamin R. Cohen, “The Element of the Table: Visual Discourse and the Preperiodic Representation of Chemical Classification,” *Configurations* 12 (2004): 71, doi:10.1353/con.2005.0001. I am grateful to the members of the PACHS Physical Sciences Working Group, particularly Michael Gordin and Babak Ashrafi, for their thoughtful and critical discussion of this article.

<sup>5</sup> Francis Preston Venable, *The Development of the Periodic Law* (Easton, PA: Chemical Publishing Co., 1896), <https://books.google.com/books?id=tF0vAQAAMAAJ>.

chemical pedagogy.<sup>6</sup> The book is quite thorough and an excellent source for nineteenth century literature on issues related to the discovery of the periodic law. Venable drew heavily on the abstract journals available at the time, most notably the abstracts volumes of the *Journal of the Chemical Society*. As an American, he also included sources which European authors might have neglected. Full of different graphical representations of the periodic system that had been published before 1896, Venable's book served as touchstone for my research. However, despite his advocacy of the pedagogical uses of the periodic system, there is little about chemical education.

The Anglo-German chemist George Rudorf learned of Venable's history after the publication of his own book, *The Periodic Classification and the Problem of Chemical Evolution*.<sup>7</sup> In the preface of the revised German edition, he described Venable's work as completely ignoring critical discussion while he himself tried to be as critical as possible.<sup>8</sup> Rudorf was a graduate student of British chemist William Ramsay; therefore the second part of his book was devoted to one of Ramsay's interests "the Problem of Chemical Evolution." The first part, however, was concerned with "the history of the periodic classification," and traced the history of

---

<sup>6</sup> His textbook, co-written with James Lewis Howe, "takes the Periodic System for its guiding principle throughout," the first to their knowledge to do so. F. P. Venable and Jas. Lewis Howe, *Inorganic Chemistry According to the Periodic Law* (Easton, PA: Chemical Publishing Co.), iii, <https://books.google.com/books?id=OPkJAAAAIAAJ>.

<sup>7</sup> George Rudorf, *The Periodic Classification and the Problem of Chemical Evolution* (London: Whittaker & Co., 1900), [https://hdl.handle.net/2027/uc1.\\$b242304](https://hdl.handle.net/2027/uc1.$b242304).

<sup>8</sup> George Rudorf, *Das periodische System, seine Geschichte und Bedeutung für die chemie Systematik* (Hamburg: Leopold Voss, 1904), ix, <https://books.google.com/books?id=sF8MAQAIAAJ>; "So sieht z. B. Venable von einer kritischen Besprechung...".

attempts to classify the elements and the history of the periodic law. Rudorf noted that his book was written in part as “the author has found that most text-books in General Chemistry allude in a more or less cursory manner to some of these periodic relations, without going into any further details.”<sup>9</sup> In the section on the uses of the periodic classification, Rudorf discussed the discovery of new elements and the properties of elements but made no mention of any pedagogical use of the periodic table.<sup>10</sup> He also only briefly discussed four “modifications of Mendeléeff’s Arrangement.”<sup>11</sup>

Listed by *School World* magazine as one of the most notable school books of 1909, albeit “For the Use of Teachers” rather than “For Class Use,”<sup>12</sup> was the British chemist A. E. Garrett’s *The Periodic Law*.<sup>13</sup> It followed a plan somewhat similar to Rudorf’s works in that it began with a survey of prior attempts to classify the elements as well as the work done to make the periodic law acceptable to chemists. Garrett spent a significant amount of time discussing the work of Thomas Carnelley, the British chemist of whom Mendeleev wrote: “The labors of Carnelley connected with the periodic law of the elements have been so remarkable that the history of the subject would be incomplete if his name were omitted.”<sup>14</sup> Other topics included applications of the periodic law, a few of the visual representations of it, and early

---

<sup>9</sup> Rudorf, *Periodic Classification*, ix.

<sup>10</sup> Rudorf, *Periodic Classification*, 142-148.

<sup>11</sup> Rudorf, *Periodic Classification*, 149-154.

<sup>12</sup> “The Most Notable School Books of 1909,” *The School World* 12 (1910): 23, [https://books.google.com/books?id=\\_pOgAAAAMAAJ](https://books.google.com/books?id=_pOgAAAAMAAJ).

<sup>13</sup> A. E. Garrett, *The Periodic Law* (New York: D. Appleton and Company, 1909), <https://archive.org/details/periodiclawthein013791mbp>.

<sup>14</sup> Quoted in Jaime Wisniak, “Thomas Carnelley,” *Educación Química*, 23 (2012): 467.

thoughts on the relationship between new discoveries regarding the atom and the periodic law.

Writing at a time in which the discoveries of atomic structure and radioactivity had changed chemists' understanding of the elements and had impacted the periodic system, German chemical educator Curt Schmidt published *Das periodische System der chemischen Elemente* in 1917.<sup>15</sup> He endeavored to trace the development of the periodic system in such a way as to show the historical continuity of ideas relating to it. Schmidt spent the first twenty pages discussing attempts to classify the elements prior to Mendeleev, and the bulk of the book on the development of the periodic system. He discussed several different graphic representations of the periodic system, many of which would have been familiar to readers at the time. Schmidt had high regard for the periodic system, having created his own graphic representation in 1911.<sup>16</sup> Despite noting that its “pedagogical significance” was “no less important” than its scientific significance, he spent little time discussing that aspect of the periodic system.<sup>17</sup>

The next significant history was published in time for the centennial of Mendeleev's discovery of the periodic law in 1969. J. W. van Spronsen's *The Periodic System of Chemical Elements* is a thorough scientific study of the history of the periodic system from the atomism of the ancient Greeks through the synthesis of

---

<sup>15</sup> Curt Schmidt, *Das periodische System der chemischen Elemente* (Leipzig: Johann Ambrosius Barth, 1917), [https://hdl.handle.net/2027/uc1.\\$b691329](https://hdl.handle.net/2027/uc1.$b691329).

<sup>16</sup> Schmidt's table is on p. 103.

<sup>17</sup> Schmidt, *Das periodische*, v; “Niemand erkennt gegenwärtig...”.



heavy elements in the 1950s.<sup>18</sup> Van Spronsen, a Dutch chemist, had published widely and in multiple languages on the periodic system and its history. As he discussed in the final chapter, the main argument of his book was that it was not solely Mendeleev who was the discoverer of the periodic system but rather six individuals, including Mendeleev.<sup>19</sup> Van Spronsen discussed in detail a great many different representations of the periodic table, ranging from precursors to the discovery of the periodic law, the various tables drawn by Mendeleev, and many versions published through the mid-twentieth century. The periodic table of American chemist Horace G. Deming, considered to as the progenitor of the current standard table, is not mentioned, nor is there much discussion of the pedagogical value of the various forms of the periodic table.

A different history of the periodic table than those already discussed comes from Russian chemists I. V. Petryanov and D. N. Trifonov. Their book, *Elementary Order: Mendeleev's Periodic System*, was intended as a supplement to chemistry textbooks.<sup>20</sup> Unsurprisingly, its focus was on Mendeleev and later Russian and Soviet contributions which affected the periodic system. There are a handful of forms of the periodic table included in the book, but they are ones created by

---

<sup>18</sup> J. W. Van Spronsen, *The Periodic System of Chemical Elements: A History of the First Hundred Years* (Amsterdam: Elsevier, 1969).

<sup>19</sup> Van Spronsen lists the following as co-discoverers of the periodic system: French geologist Alexandre-Émile Béguyer de Chancourtois, British chemists William Odling and John Alexander Reina Newlands, Danish-American scientist Gustavus Hinrichs, German chemist Lothar Meyer, and Russian chemist Dmitrii Mendeleev; see Van Spronsen, *Periodic System*, chapters 5 and 16.

<sup>20</sup> I. V. Petryanov and D. N. Trifonov, *Elementary Order: Mendeleev's Periodic System*, trans. Nicholas Weinstein (Moscow: Mir Publishers, 1984). Revised from the Russian edition, 1976.

Mendeleev, including a “modern version of Mendeleev’s periodic table.”<sup>21</sup> It is clear that within the Soviet Union, the standard periodic table of the elements in use was an updated version of what was at one time referred to in Europe and the United States as “Mendeleev’s table,” the short form table first published by him in 1871. The most significant difference between these two versions is the incorporation of electron shell information and the location of the lanthanides and actinides in separate rows underneath the main table, as they are on the standard table used by most of the world.

In the twenty-first century, interest in the periodic table has undergone a revival by chemists, as well as by historians and philosophers of chemistry. The most recent history of the periodic table is Eric R. Scerri’s *The Periodic Table: Its Story and Its Significance*.<sup>22</sup> Scerri is a chemist and a philosopher who is heavily involved in the revival of the field of the philosophy of chemistry. His major interest lies in the problem of the reduction of chemistry to quantum mechanics. He makes it quite clear that the purpose of this book is philosophical, not historical. Scerri is very concerned with the impact physics has made on chemistry and on the periodic table. Although he comments on the standard table, its existence is largely treated as a *fait accompli*. When discussing various representations of the periodic law,

---

<sup>21</sup> They note that this updated version “fully complies” with the electronic configuration of the elements; see *Elementary Order*, 71-72.

<sup>22</sup> Eric R. Scerri, *The Periodic Table: Its Story and Its Significance* (New York: Oxford University Press, 2007). A briefer and somewhat revised version of this is available as *The Periodic Table: A Very Short Introduction* (Oxford: Oxford University Press, 2011).

Scerri is more concerned with whether or not there is a true form of the periodic table, a topic of debate amongst some philosophers of chemistry.<sup>23</sup>

The work that most directly addresses the questions about the creation and implementation of the current standard form of the periodic table is the essay by historian and philosopher of chemistry Bernadette Bensaude-Vincent, “Graphic Representations of the Periodic System of Chemical Elements.” She argues the “competition” between forms in the twentieth century indicated a change in the function of the periodic system from “an adequate representation of a law of nature” to “a teaching device.”<sup>24</sup> The current standard table is thus a compromise of sorts, arrived at largely for pedagogical reasons: an intermediate form between popular short and long forms of the periodic table, as well as a compromise between chemistry and physics. As for the origin of this standard form, Bensaude-Vincent has only speculations. Noting that the IUPAC was not a “driving force,” she suggested that perhaps it was the Americans, under the leadership of Nobel laureate Glenn T. Seaborg, who “played a key role.”<sup>25</sup>

I have found little evidence of any organized effort by American chemists to institute a standard table. During the early Cold War period, there was an effort to redesign chemical education in the United States, the Chemical Education Material Study (CHEM Study) project, similar to the Physical Science Study Committee (PSSC) and the Biological Sciences Curriculum Study (BSCS) programs. However, by the

---

<sup>23</sup> Since the publication of this book, Scerri has moved away from this idea.

<sup>24</sup> Bernadette Bensaude-Vincent, “Graphic Representations of the Periodic System of Chemical Elements,” in *Tools and Modes of Representation in the Laboratory Sciences*, ed. U. Klein, (Dordrecht: Kluwer Academic Publishers, 2001), 144.

<sup>25</sup> Bensaude-Vincent, “Graphic Representations,” 151.

time the CHEM Study project began in 1959, the standard form had already overtaken other forms in textbooks.<sup>26</sup> Although Seaborg was involved in CHEM Study and was a great proponent of the periodic table's utility in both research and education, neither his writings nor his papers reveal that he had any involvement with standardizing any particular form of the periodic table.

Bensaude-Vincent mentions the periodic table created by the American chemical educator Horace G. Deming as being an influential one. My research shows that Deming's table can be considered the progenitor of the current standard form. It first appeared in 1923, in the first edition of his textbook *General Chemistry*. Deming's textbooks proved extremely popular, the final editions being published in the 1950s. During those three decades, his table was printed and distributed by scientific supply companies, both as complimentary vest pocket versions as well as for purchase in a variety of sizes from vest pocket to wall chart, and it became the first periodic table to be included in several standard chemical and physical handbooks, such as the *CRC Handbook of Chemistry and Physics*. It thus achieved wide recognition first in the United States and then in Europe. By the mid-1950s, the current standard form, based on Deming's table, had usurped other forms in chemical textbooks.

Bensaude-Vincent's essay served as a jumping off point for my own research. After confirming that neither Seaborg nor the IUPAC were involved in the establishment of the current standard form of the periodic table, I was left with her

---

<sup>26</sup> For more on CHEM Study, see Richard J. Merrill and David W. Ridgway, *The CHEM Study Story* (San Francisco: W. H. Freeman and Company, 1969), <https://archive.org/details/chemstudystory00merr>.

claim about the changing role of the periodic table from a research to a pedagogical tool. This dissertation takes up this proposition and asserts that chemical educators have been the driving force behind the continual development of different forms of the periodic table. It was the need to better serve their students that drove educators to experiment with different graphic representations of the periodic law, whereas chemical researchers were largely content to use Mendeleev's table despite its known deficiencies. And when the number of different tables in use became overwhelming, it was chemical educators who saw the need for the use of a standard form of the table, one more suited to serving the needs of chemistry students at varying levels of the educational spectrum.

There is no doubt that many forms of the periodic table were created by chemical researchers for research purposes. But the general trend is of a more pedagogical than a research nature. This is true even before the discovery of the periodic law in 1869. The general classification system of the elements in use was known to be problematic and it was for pedagogical reasons that chemists developed different classification schemes. They may have presented these systems in such a way as to emphasize their utility for research, but the origin of the system was frequently acknowledged to be the confusion of and difficulties encountered by their students in learning about the elements. The development of new classification systems and new graphical representations of the periodic law have largely been about practicality rather than about theory. Chemistry is a science grounded in experiment and the senses, and its tools reflect practicality and utility.

For chemical educators, it only makes sense that pedagogical tools are likewise practical – and standardized.

### **A Standard Form of the Periodic Table**

This dissertation concerns the development of a standard form of the periodic table. What do I mean by that? The current standard form is the form of the periodic table most commonly found in textbooks today throughout most of the world. It is rectangular, eighteen columns wide and seven rows long, with two rows lying perpendicular beneath the main body of the table.<sup>27</sup> The columns lose height as they move towards the center, creating something of a castle-like shape with a moat beyond which lies the two rows containing the lanthanides and the actinides. Each square within the table contains the information about one element – name, symbol, atomic number, atomic weight – and the elements are arranged in numerical order by their atomic number, from 1 to 118.

This table varies slightly from text to text and wall chart to wall chart. Sometimes there is a little more or a little less information about each element, depending on the purpose of the particular table. Different colors can be used to differentiate between blocs or groups of elements (or there may be no color at all). Arrows or lines connect the two rows beneath the table to the place they would reside within the main table, and/or symbols are used to draw attention to this.

---

<sup>27</sup> These numbers will most likely change. In 2016, the IUPAC officially announced the discovery and naming of elements 113, 115, 117, and 118, completing the seventh row of the periodic table. Within the next two decades it is likely that an eighth row will be added to the periodic table, and quite possibly a third row underneath the main body. It is less likely that a nineteenth column will be added, unless an entirely new type of element is discovered.

Some differences reflect issues that are currently contentious: the use of Arabic numerals 1 through 18 to label the columns or the use of Roman numerals I through VII with A and B subgroup labels; the use of the terms actinides and lanthanides as opposed to actinoids and lanthanoids to describe the elements contained in the two rows beneath the table; the placement of actinium and lanthanum in the main table or at the start of those two bottom rows. These differences, however, do not change the basic form of the table.

The development of this current standard form of the periodic table does not appear to have followed recognized pathways of standards creation.<sup>28</sup> There was no committee or group formed for the purpose. As mentioned earlier, the international chemical standards body, the IUPAC, encourages chemists and chemical educators to use this form but will not enforce its use, nor does it recommend any particular form of the periodic table. The official IUPAC stance regarding the periodic table is:

IUPAC has not approved any specific form of the periodic table, and an IUPAC-approved form does not exist, though even members of IUPAC themselves have published diagrams titled “IUPAC Periodic Table of the Elements.” However, the only specific recommendation IUPAC has made concerning the periodic table covers the Group numbering of 1–18.<sup>29</sup>

Yet somehow a general uniformity in form developed and became widely diffused.

The sociologist Lawrence Busch notes that “the emergence of standards is almost

---

<sup>28</sup> For more on standards and their creation, see Nils Brunsson, and Bengt Jacobsson, *A World of Standards* (Oxford: Oxford University Press, 2000) and Craig N. Murphy, and JoAnne Yates, *The International Organization for Standardization (ISO): Global Governance Through Voluntary Consensus* (New York: Routledge, 2009).

<sup>29</sup> G. Jeffery Leigh, “Periodic Tables and IUPAC,” *Chemistry International* 31 no. 1 (2009): 4, doi:10.1515/ci.2009.31.1.4. Although using Arabic numerals 1-18 as group labels is official IUPAC policy, the change was controversial among some groups and is not always used.

invariably the result of conflict or disagreement,” after which a consensus emerges.<sup>30</sup> There was certainly much disagreement over which form of the periodic table was best. As I show in this dissertation, this was particularly true in the case of pedagogical use, where the disagreements between and emerging consensus among chemical educators resulted in the current standard form of the periodic table.

Chemists have always been interested in the visual representation of the periodic law. Different tables assisted chemical researchers in the development of the periodic system after 1869. After about 1914, the importance of the table for research purposes began to decrease as the periodic system was thoroughly supported by experimental evidence and had gained a theoretical background. Chemical educators continued to take an interest in the graphical representation as the deficiencies of Mendeleev’s short table well-known and it was generally agreed it could be improved upon.

Mendeleev himself found the tabular form to be inadequate in representing the periodic law and he continued to draw new versions until his death. But he rejected curves and spirals as being even less adequate. His rejection was less about the visual appeal of a table and more about the correct representation of the law itself:

This method, although graphic, has the theoretical disadvantage that it does not in any way indicate the existence of a limited number of elements in each period. ... The actual periodic law does not correspond with a continuous change of properties, with a continuous variation of atomic weight – in a word, it does not express an uninterrupted function....

---

<sup>30</sup> Lawrence Busch, *Standards: Recipes For Reality* (Cambridge, MA: MIT Press, 2011), 33.



Rather, the periodic law, “*above all*, depends on there being but a few types of chemical compounds, which are arithmetically simple, *repeat themselves*, and offer no uninterrupted transitions, and therefore each period can only contain a definite number of members.”<sup>31</sup> In other words, a table better represented the major features of the periodic law.

As shown by the great variety of periodic tables drawn in the last 150 years, many chemists have been dissatisfied with the form of the periodic table, though many have also disagreed with Mendeleev about tabular forms being superior to circular and helical forms. How many different forms of the periodic table exist today? It is hard to know for sure but an estimate of one thousand is not beyond belief.<sup>32</sup> In his 1974 book *Graphic Representations of the Periodic System During One Hundred Years*, Edward G. Mazurs collected over 700 versions of the periodic table.<sup>33</sup> Mazurs, a Latvian chemist and chemical educator who emigrated to the United States after World War II, created a complex classification scheme with which to organize these tables. The book is a discussion of his classification scheme and how each version of the periodic table fits within it.

---

<sup>31</sup> D. Mendeléeff. *The Principles of Chemistry*, from the 5<sup>th</sup> Russian ed., trans. by George Kamensky, ed. by A. J. Greenaway (London: Longmans, Green, and Co., 1891), 2:19, <https://books.google.com/books?vid=HARVARD:HWSSE6>; emphasis in original.

<sup>32</sup> There are too many versions of the periodic table of the elements to accurately count. For a very large selection of tables, including those among the most recent, see Mark R. Leach, “The Internet Database of Periodic Tables,” [http://www.meta-synthesis.com/webbook/35\\_pt/pt\\_database.php](http://www.meta-synthesis.com/webbook/35_pt/pt_database.php).

<sup>33</sup> Edward G. Mazurs, *Graphic Representations of the Periodic System During One Hundred Years* (University: The University of Alabama Press, 1974), revised (2<sup>nd</sup>) ed. of *Types of Graphic Representation of the Periodic System of Chemical Elements* (LaGrange: 1957).

A far simpler classification of periodic table forms was devised by chemist G. N. Quam and his librarian wife Mary Battell Quam.<sup>34</sup> They divided tables into five categories, each of which could have several subcategories: short tables, long charts, spiral charts, helical charts, and miscellaneous charts. Short charts are rectangular with no more than nine columns, such as Mendeleev's 1871 table, while long charts are longer tables that have more in common with today's standard form. Spiral charts were differentiated from helical charts as being flat, two-dimensional tables rather than three-dimensional arrangements. Miscellaneous tables were forms that did not necessarily fit into one of the five main categories.

The Mazurs and the Quams created their classification schemes for similar reasons. The Quams hoped to provide students with "a fairly comprehensive view" of the different types of tables that had been created by chemists "to overcome objectionable features of systems then in the literature, and to produce a more useful instrument."<sup>35</sup> Mazurs's classification system not only showed "the gradual evolution of the graphical presentation," but "reduce[d] the number [of representations] to one hundred forty-six."<sup>36</sup> Mazurs concluded there were three different uses of the periodic table – none of which were purely pedagogical – and, depending on the use, a different type of table was best. He did not recognize a

---

<sup>34</sup> G. N. Quam and Mary Battell Quam, "Types of Graphic Classifications of the Elements," *Journal of Chemical Education* 11 (1934): 27-32, 217-223, 288-297, doi:10.1021/ed011p27; 10.1021/ed011p217; 10.1021/ed011p288.

<sup>35</sup> Quam and Quam, "Types," 28.

<sup>36</sup> Mazurs, *Graphic Representations*, xi.

single table as being better than all others but expressed a preference for three tables – not surprisingly one of these was his own.<sup>37</sup>

That more than one individual has taken the time and effort to create classification schemes, both simple and complex, for the variety of graphic representations of the periodic law illustrates not only the surprisingly large number of such representations but also the importance of the periodic table to chemistry. But none of these classification schemes was focused on the pedagogical use of the table. The Quams's scheme was intended to give students a historical overview of the different forms of the periodic table, but they did not make any suggestions as to which might be the best for use by students. Mazurs occasionally noted some teachers preferred a particular feature, therefore a particular type was best for that particular use, but did not make any judgments as to which tables might be better suited for classroom use. In this dissertation, I am likewise not suggesting that any particular table is best, but I do argue that chemical educators came to a consensus that one table, out of the great many being used, was needed as a standard for use in the classroom.

### **Chemical Education and the Periodic Table**

One of the ways standardization and uniformity in education come about is through textbooks. The historian Thomas S. Kuhn argued that “whenever the language, problem-structure, or standards of normal science change,” these changes become enshrined in textbooks.<sup>38</sup> Consequently, textbooks are “the unique

---

<sup>37</sup> Mazurs, *Graphic Representations*, 136-137.

<sup>38</sup> Thomas S. Kuhn, *The Structure of Scientific Revolutions*, 3<sup>rd</sup> ed. (Chicago: The University of Chicago Press, 1996), 137.

repository of the finished achievements of modern physical scientists” and assist in passing on and reinforcing consensus.<sup>39</sup> Kuhn’s theory of textbooks is a research-down one, in which new theories are tested, accepted, and approved by researchers before moving into the realm of pedagogy. This view regards textbooks as “mere transmission tools,” belonging to what historians Antonio García-Belmar, José Ramón Bertomeu-Sánchez, and Bernadette Bensaude-Vincent describe as “a regime of accumulation and reproduction of knowledge” and not to “a regime of innovation and creation.”<sup>40</sup>

Echoing Kuhn, historians of science held the view that textbooks were “not the place to look if one wishes to recover the creative moment in scientific innovation or the stirring controversies through which scientific knowledge is forged.”<sup>41</sup> This view has begun to change.<sup>42</sup> Textbooks – and pedagogy in general – are now acknowledged as sites of creativity and innovation, not as mere storehouses of accepted knowledge. The content of textbooks can lead their audiences, whether they be students or other scientists, down new research paths.

---

<sup>39</sup> Thomas S. Kuhn, “The Function of Measurement in Modern Physical Science,” in *The Essential Tension: Selected Studies in Scientific Tradition and Change*, Thomas S. Kuhn (Chicago: The University of Chicago Press, 1977), 227.

<sup>40</sup> Antonio García-Belmar, José Ramón Bertomeu-Sánchez, and Bernadette Bensaude-Vincent, “The Power of Didactic Writings: French Chemistry Textbooks of the Nineteenth Century,” in *Pedagogy and the Practice of Science: Historical and Contemporary Perspectives*, ed. David Kaiser (Cambridge: The MIT Press, 2005), 222.

<sup>41</sup> Brooke, John Hedley, “Introduction: The Study of Chemical Textbooks,” in *Communicating Chemistry: Textbooks and Their Audiences, 1789-1939*, ed. Anders Lundgren and Bernadette Bensaude-Vincent (Canton, MA: Science History Publications/USA, 2000), 1.

<sup>42</sup> For more on the evolving field of the history of science education, see John L. Rudolph, “Historical Writing on Science Education: A View of the Landscape,” *Studies in Science Education* 44 (2008): 63-82.

And the act of creating a textbook can likewise lead to the development of new knowledge.

Textbooks played a large role in the discovery of the periodic law. The German chemist Lothar Meyer was in the process of writing a textbook when he developed his first table of the elements, and the Russian chemist Mendeleev was likewise engaged in the process of textbook writing when he discovered the periodic law in 1869. Bensaude-Vincent argues it was, in part, from the systematization of ideas – the summarizing and ordering of “scattered, isolated facts and laws” – that the periodic law emerged.<sup>43</sup> The historian Nathan M. Brooks similarly argues that “the pedagogical demands of writing a textbook ... acted as a constraint which channeled Mendeleev’s thoughts in terms of classification and comparison.”<sup>44</sup> The ideas may have been in the air but it was the act of writing a textbook that put Mendeleev and Lothar Meyer in the position necessary for those ideas to coalesce into the periodic law.

The periodic table was far from a “finished achievement” in 1869 – and with the regular addition of new elements to the table and the continued development of new forms, one might say it is still not finished. Pedagogical activity was, and continues to be, a driving force behind the development of new graphical representations of the periodic law. New forms of the table were frequently

---

<sup>43</sup> Bernadette Bensaude-Vincent, “Mendeleev’s Periodic System of Chemical Elements,” *British Journal for the History of Science* 19 (1986): 3, <http://www.jstor.org/stable/4026481>.

<sup>44</sup> Nathan M. Brooks, “Dmitrii Mendeleev’s *Principles of Chemistry* and the Periodic Law of the Elements,” in *Communicating Chemistry: Textbooks and Their Audiences, 1789-1939*, ed. Anders Lundgren and Bernadette Bensaude-Vincent (Canton: Science History Publications, 2000): 306.

published in journals, often with a note that it was a form developed by the author for use in the lecture hall and had been favorably received by students. From its first appearance in a textbook in the 1870s, textbook authors did not shy away from criticizing Mendeleev's table and suggesting that another form – sometimes of the author's creation, sometimes not – was more useful for students to learn about the elements.

Chemical educators were prolific in creating new graphical representations of the periodic law, striving to make it easier for their students to learn about the elements and their relationships. By 1939, there were so many different forms in use that chemistry professor Laurence S. Foster issued the following plea in the pages of *Journal of Chemical Education*:

It seems to me that it is high time for some organization, such as the Division of Chemical Education of the American Chemical Society, to sponsor a simpler and more useful form of the table and to make an effort to induce textbook writers to adopt it as the standard type. Until the authors of secondary-school and college textbooks have been led to accept the modern periodic table, the readers will continue to be handicapped and confused in their thinking about the periodicity of chemical and physical properties.<sup>45</sup>

Foster implied that the periodic table was the most important part of a chemistry textbook. Whether this is true or not, the periodic system and chemical education have been closely tied from the start.

Another important aspect of science pedagogy that deserves mention, particularly in relation to the periodic table, are wall charts. The historical literature on wall charts is slim. The main article on the use of scientific wall charts is an essay

---

<sup>45</sup> Laurence S. Foster, "Why Not Modernize the Textbooks Also? I. The Periodic Table," *Journal of Chemical Education* 16 (1939): 410, doi:10.1021/ed016p409.

by historian Massimiano Bucchi in which he argues that wall charts grew out of the tradition of illustrations in scientific textbooks and atlases. According to Bucchi, wall charts are “images explicitly designed to be displayed in the classroom,” and were first produced in the 1820s.<sup>46</sup> However, there is evidence that wall charts were used much earlier. Historian Georgette Taylor shows that lecture notes taken by students of the British chemist William Cullen described an enlarged copy of Cullen’s affinity table pinned up in the lecture hall. Cullen also arranged for the printing of affinity tables to sell to students.<sup>47</sup> Similar avenues were taken by chemical educators with regard to the periodic table in the classroom and lecture hall when commercial charts were unavailable or when alternate representations were used.

From at least the 1890s in Germany and the first decade of the twentieth century in the United States, chemical supply companies sold and distributed periodic tables in the form of wall charts, as well as pocket charts and standard page-sized charts, for use not only in laboratories but in classrooms. The best-selling American wall chart is The Periodic Chart of the Atoms, first designed in 1924 by Henry Hubbard, a scientist at the National Bureau of Standards, and sold by Welch Scientific. The chart is still sold today – virtually unchanged aside from the addition of new elements and corrections in atomic weights. Sargent-Welch

---

<sup>46</sup> Massimiano Bucchi, “Images of Science in the Classroom: Wallcharts and Science Education 1850-1920,” *British Journal for the History of Science* 31 (1998): 163, <http://www.jstor.org/stable/4027761>.

<sup>47</sup> Georgette Taylor, “Marking Out a Disciplinary Common Ground: The Role of Chemical Pedagogy in Establishing the Doctrine of Affinity at the Heart of British Chemistry,” *Annals of Science* 65 (2008): 473, doi:10.1080/00033790701754290.

describes it as being “recognized throughout the world as one of the most authoritative and comprehensive periodic references.”<sup>48</sup> The Periodic Chart of the Atoms is not the only periodic chart sold by Sargent-Welch, which also sells periodic chart games, bookmarks, mouse pads, and more. Whatever its form or how colorful it may or may not be, the periodic table has been and continues to be integral to chemical education.

The role of scientific supply companies in spreading specific forms of the periodic table has not, to my knowledge, been studied. But it seems likely that their influence was significant. In his study of biological teaching materials used in the United States during the 1960s, historian John L. Rudolph argues that “the material components of science instruction,” such as wall charts, are “more central ... to imparting ideas about scientific epistemology than any lecture or textbook exposition.”<sup>49</sup> Instructional materials, however, are generally acquired through scientific and educational supply companies who are subject to technical, financial, and political constraints that may be unrelated to those of educators and researchers.<sup>50</sup> These constraints can have a very real effect on students. This aspect of the history of the periodic table – the roles played by scientific supply companies and textbook publishers – is only touched on in this dissertation but is deserving of more attention.

---

<sup>48</sup> Sargent-Welch, “Periodic Chart of the Atoms,” <http://sargentwelch.com/periodic-chart-of-the-atoms/p/IG0039635/>.

<sup>49</sup> John L. Rudolph, “Teaching Materials and the Fate of Dynamic Biology in American Classrooms after Sputnik,” *Technology & Culture* 53 (2012): 2, doi:10.1353/tech.2012.0037.

<sup>50</sup> Such constraints apply to textbooks and their authors, as well; see García-Belmar, Bertomeu-Sánchez, and Bendaude-Vincent, “Power of Didactic,” 222.



Regardless of how great or small a role they played in the development of a standard form of the periodic table, scientific supply companies and textbook publishers were only one of the key players. Chemical educators and students also had key roles. The role of pedagogy in the development of the form of the periodic table has been a neglected one. The history of science education has been considered to be a niche field, but the last two decades have shown a marked increase in the number of studies of science textbooks in general and chemistry textbooks in particular. This dissertation is an addition to this field, as well as to the larger field of the history of the periodic table.

### **Research Choices**

All historians make choices about their work. These are often conscious choices regarding aspects such as the period of time studied, the sources used, the focus on a particular actor or actors, or the concentration on the role of social or economic factors. Sometimes these choices are made by necessity, such as time and/or funding available for research travel. One such choice for this dissertation is language – for the most part I speak and read only English. My ability to read French is basic, though I can muddle through with the assistance of a dictionary. But on the whole languages and I do not get on well.

This is important to note because it skews my research by limiting the sources I can use. As historian Michael Gordin notes in his study of scientific languages, linguistic citation bias is a seemingly universal phenomenon: “Scholars disproportionately cite literature in the languages they feel most comfortable with,

which are often their native languages.”<sup>51</sup> The majority of the works cited in this dissertation are works in English. Many of the non-English language works that are cited also have English translations, whether those are abstracts, excerpts, or full translations. For those foreign language works that do not have translations, I have relied on the translations and interpretations of other scholars, and occasionally upon Google Translate. I readily acknowledge that Google Translate is far from perfect and does not handle scientific words, particularly nineteenth and early twentieth century words, very well. When using it, I have tried to compare the results with what other scholars have said about the opinions of the author regarding the subject matter. If I could not reconcile the Google translation with this, I have tried to use other sources instead.

I feel it is important to state this because, despite what many may think, science is not a universal language. Translation is “the process of transforming a specific piece of one language (commonly a text of some sort) into another language.”<sup>52</sup> This process is not a trivial matter. Knowledge is a form of culture<sup>53</sup> thus meaning can change or get lost when translation from one language to another occurs. The scholar of translation Scott L. Montgomery illustrates this in his discussion of the translation of Western chemical knowledge into Japanese. In his translations, the Japanese scholar Udagawa Yoan modeled the suffix used for elements on that of the Dutch/German suffix *-stoff*. This suffix had a particular

---

<sup>51</sup> Michael D. Gordin, *Scientific Babel: How Science Was Done Before and After Global English* (Chicago: The University of Chicago Press, 2015), 10.

<sup>52</sup> Scott L. Montgomery, *Science in Translation: Movements of Knowledge Through Cultures and Time* (Chicago: The University of Chicago Press, 2000), 4.

<sup>53</sup> Montgomery, *Science in Translation*, 2.

philosophical meaning which illustrated an older (somewhat alchemical) understanding of the elements that was not necessarily shared by chemists in all Western countries. In turn, this influenced chemical discourse in Japan in a particular way.<sup>54</sup>

Cultural traditions are not the only problem one encounters with translation. Gordin makes the point that “papers contain more than isolated chemical formulae and mathematical equations. You read descriptions of the reaction, analyses of colors and odors, detailed explanations of method.”<sup>55</sup> This is particularly important when doing research on new areas of science, ones that cross sub-disciplines and disciplinary lines. Radioactivity, one of the major subjects covered in this dissertation, was a ground breaking area of scientific research, one which required chemists and physicists to communicate with each other. They viewed many things, including atoms and atomic theory, in very different ways. Historian Mary Jo Nye notes that these differences created a situation in which “the languages of physics and chemistry had distinct uses in the two different disciplinary communities.”<sup>56</sup> It was hard enough to communicate in one language, let alone in more than one language and more than one discipline.

Sources used are another important choice in this dissertation. This choice is part conscious and part necessity. Traditional archives and their collections are wonderful things and can yield unique and exciting information, but travel to them

---

<sup>54</sup> Montgomery, *Science in Translation*, 238-241.

<sup>55</sup> Gordin, *Scientific Babel*, 11.

<sup>56</sup> Mary Jo Nye, *Before Big Science: The Pursuit of Modern Chemistry and Physics, 1800-1940* (Cambridge: Harvard University Press), 50.

requires often not insignificant funds. As a large part of this dissertation concerns chemical pedagogy in the nineteenth and early twentieth centuries, most of the sources I have used are journals and textbooks. This turned out to be a very fortunate thing for my pocketbook. Thanks to projects such as Google Books, the Hathi Trust, the Internet Archive, the Biodiversity Heritage Library, and Gallica, the digital library of the Bibliothèque nationale de France, large numbers of pre-1923 journals and books are readily available, full-text, at no charge, on the Internet.<sup>57</sup> Interlibrary loan was extremely helpful in obtaining sources that were not available to me online.

The decision to use primarily journals and textbooks is due also their significance to the process of science. The historian Christoph Meinel stated that scientific communication occurs in two ways. "First, it transfers and preserves the stock of accepted knowledge from one generation to the next."<sup>58</sup> Textbooks, handbooks, and other activities related to the teaching of science account for this method. Chemical textbooks have thus been one of the major sources used in this dissertation, enabling me to follow the integration of the periodic law into pedagogy and to note the changes in the use of the periodic table and its forms. Locating wall

---

<sup>57</sup> 1923 is an important date in United States copyright law. Works published or registered in the United States before 1923 are considered to be in the public domain unless their copyright was renewed, thus there are no restrictions on making the full-text freely available. See Peter Hirtle, "Copyright Term and the Public Domain in the United States," Cornell University Library, <http://copyright.cornell.edu/resources/publicdomain.cfm>.

<sup>58</sup> Christoph Meinel, "Structural Changes in International Scientific Communication: The Case of Chemistry," in *Atti del V Convegno Nazionale di Storia e Fondamenti della Chimica*, ed. Gianlorenzo Marino (Rome: Accademia Nazionale delle Scienze, 1994), 47, <http://nbn-resolving.de/urn/resolver.pl?urn=urn:nbn:de:bvb:355-epub-135639>.

charts has been much harder than locating textbooks. I have largely relied on references in articles and texts by chemical educators as well as photographs that I have been able to locate on the Internet and in books. There are far fewer of those, consequently wall charts do not play as large a role in this dissertation as they deserve.

The second way that scientific communication occurs, according to Meinel, is through “new channels of information that enable rapid exchange and critical feedback, provided e.g. by meetings, correspondence, preprints, and journals.”<sup>59</sup> Meetings sometimes, though not always, result in published proceedings; correspondence, with few exceptions, is found only in archival collections; and preprints are a phenomenon of the late twentieth century. Journals are by far the most readily and easily available resource, though they are not without limitations of their own.

The rapid exchange of experimental results and theoretical ideas, as well as critical feedback, is vitally important to science. The most important venue for this during most of the period covered by this dissertation is the scientific journal. Historian Alex Csiszar argues that during the nineteenth century, “a monumental shift [occurred] whereby scientists increasingly perceived the social and intellectual life of science to be lodged in the pages of the specialized scientific literature, and especially in the expansive terrain of the scientific periodical.” Periodicals were not only the venue for communication but they also became the place in which priority

---

<sup>59</sup> Meinel, “Structural Changes,” 47.

claims were made and decided, and the site that housed the record of scientific achievements.<sup>60</sup>

In chemistry, according to the historian William H. Brock, by the end of the eighteenth century periodicals had replaced the monograph as the means for “conveying new chemical knowledge and for settling controversial issues.”<sup>61</sup> The major chemical societies each had at least one journal that published the papers of their members. Many also carried abstracts and translations of papers found in foreign journals. Most of these journals, however, were published on a quarterly or monthly basis. These journals also, as the chemist Martin D. Saltzman showed, published more papers in the subdisciplines of chemistry most favored in their countries. For example, when the *Berichte* of the German Chemical Society was first published in 1868, the vast majority of its papers concerned organic chemistry, the subdiscipline occupying most German chemists. The Chemical Society of London’s *Quarterly Journal*, on the other hand, had a more equitable disposition of papers between organic, inorganic, analytical, and physical chemistry, reflecting the variety of interests of British chemists.<sup>62</sup>

In contrast, the *Chemical News* was a commercial publication, carrying on a tradition that began with *Nicholson’s Journal* at the beginning of the nineteenth

---

<sup>60</sup> Alex Csiszar, “Seriality and the Search for Order: Scientific Print and Its Problems During the Late Nineteenth Century,” *History of Science* 48 (2010): 400, doi:10.1177/007327531004800306.

<sup>61</sup> William H. Brock, *The Norton History of Chemistry* (New York: W. W. Norton & Company, 1993), 436.

<sup>62</sup> Martin D. Saltzman, “Chemical Societies and Their Journals: What Can Be Learned About the State of Chemistry From an Analysis of the First Volumes of These Journals,” *Bulletin of the History of Chemistry* 31 (2006): 19-27, [http://www.scs.illinois.edu/~mainzv/HIST/bulletin\\_open\\_access/bull-index.php](http://www.scs.illinois.edu/~mainzv/HIST/bulletin_open_access/bull-index.php).

century, and to some extent the *Philosophical Magazine*, as well.<sup>63</sup> Commercial scientific journals came from the tradition of non-scientific publications and were regarded as more egalitarian – and more lively. Because the *Chemical News* was not tied to a particular scientific society, anyone could submit a paper with reasonable hopes that it would be published. The *Chemical News* was published weekly, rather than monthly or quarterly, which allowed not only for news to be disseminated more quickly but for debates about new discoveries and theories to be carried on in its pages by means of letters to the editor or short papers. It contained a variety of papers, translations and abstracts from other publications and from scientific meetings, and book reviews, as well as advertisements for products and services and a yearly student number which provided detailed information about the chemical education available at various schools in Great Britain. The intention was for the *Chemical News* to cover all chemical areas, from public health and pharmacy to physical chemistry, so as to appeal to a broad audience. The weekly had high circulation rates, not only within Britain and the British Empire, but on the Continent and in the United States.

The editor and publisher of the *Chemical News* was William Crookes, a scientist and journalist, who made his living as a chemical analyst and publisher.<sup>64</sup> Unsurprisingly, the *Chemical News* reflected Crookes's interests, one of which was

---

<sup>63</sup> Iain Watts, "We Want No Authors': William Nicholson and the Contested Role of the Scientific Journal in Britain, 1797-1813," *British Journal for the History of Science* 47 (2014): 397-419, doi:10.1017/S0007087413000964.

<sup>64</sup> Brock, *Norton History*, chapter 13. For more on Crookes, see William H. Brock, *William Crookes (1832-1919) and the Commercialization of Science* (Aldershot: Ashgate, 2008).

the metaphysical, and he hoped “to encourage ideas about the ultimate nature of matter.”<sup>65</sup> Therefore, the *Chemical News* frequently published papers on the nature of the elements, including their periodicity and different methods to classify them, as well as papers on Prout’s hypothesis, a postulation that there is a primary matter out of which all elements are created. Crookes also took a great interest in radioactivity when it was first discovered and the *Chemical News* was one of the earliest chemical journals to provide coverage of the subject.

The *Chemical News* is one of the major sources I have relied upon for many reasons. Its frequent publication and the emphasis Crookes placed upon “encourag[ing] ideas about the ultimate nature of matter” has allowed me to gauge the changing attitudes of scientists towards the periodic law as well as to see how scientific discoveries and philosophical theories impacted its development and use. The publication of abstracts, translations, and book reviews has led me to sources, both English and foreign language, I otherwise might not have discovered. While it is far from the only scientific periodical I have used, I think it is important to note the role that the *Chemical News* has played in my research for this dissertation.

Another set of periodicals that have been important in my research are chemical education journals. As Foster noted in his 1939 article, chemistry textbooks were not consistent in their use of graphic representations of the periodic table. Many of those who create new periodic tables state that their version is better for educating students about the periodic system. Unsurprisingly then, science and chemistry education journals are hotbeds of discussion about the

---

<sup>65</sup> Brock, *Norton History*, 458.



history and philosophy of the periodic table as well as of the standard form of the periodic table and other visual representations. Among the journals that frequently publish articles on the periodic table are the *Journal of Chemical Education*, *The Chemical Educator*, *School Science Review*, *Canadian Chemical Education*, *Education in Chemistry*, and *The Science Teacher*. The number of articles on representations of the periodical table submitted to the *Journal of Chemical Education* since its first issue in 1924 has been so great that in 2010 the editor was forced to limit them solely to “those that cover new ground,” stating that “continuing arguments on longstanding issues will not be accepted for review.”<sup>66</sup>

The editor notes that two of the roles of the *Journal of the Chemical Education* are “encouraging open discussion and highlighting creativity.” When it came to the periodic table, however, he chose to err on the side of creativity.<sup>67</sup> It is impossible to ignore the creativity of chemical educators when it comes to the periodic table. For the purposes of this dissertation, discussions and arguments over longstanding issues are also of great interest. It was through both argument and creativity that chemical educators eventually came to a consensus over the need for a standard form of the periodic table and that the current standard form overtook most others in the classroom.

\*\*\*\*\*

---

<sup>66</sup> Norbert J. Pienta, “Editor’s Note,” *Journal of Chemical Education* 87 (2010): 783, doi:10.1021/ed100436f.

<sup>67</sup> Pienta, “Editor’s Note,” 783.

This dissertation is divided into six chapters. The first and sixth chapters constitute, respectively, the introduction and conclusion. The remaining four parts, chapters 2 through 5, are chronological. They follow the development of chemical classification from the beginning of the nineteenth century to the discovery of the periodic law in 1869, and the continued development of the periodic law and its graphic representations into the second half of the twentieth century. These chapters also examine changing ideas about the elements and how they are defined, which played an important role in the development of classification systems as well as the graphic representation of the periodic system.

The classification and organization of the elements was a topic of great interest to chemists throughout the nineteenth century. Chapter 2 highlights the practical nature of the development of a classification scheme that would encompass all of the elements, not just small groups. A complete system would be of great benefit in the laboratory, but it would also be a great benefit in the classroom. The complex nature of the relationship between research and education is shown in the attempts of researcher-educators to develop organizational schemes. While many held a traditional view of the division between the two areas, textbook authors increasingly began to advocate for their own theories and beliefs rather than already tested and accepted ideas.

Chapter 3 begins with the discovery of the periodic law and follows its acceptance and development. It shows how chemists, although still highly reliant on experimental evidence, were challenged by the periodic law to consider a middle ground in which empiricism and theory could be of equal utility. The periodic

system enabled chemists to predict the existence of new elements and their characteristics while also seeming to bolster more philosophical notions about their evolution. Proponents of these theories also used visual representations, looking remarkably like those of the periodic system, to illustrate their ideas. This chapter also emphasizes the great impact of the periodic system on chemical education. Chemical educators began to reorganize their curricula around it and to create different graphical representations for use in textbooks and in the lecture hall. By the end of the nineteenth century, the periodic system was an integral part of chemical pedagogy.

Great changes in the physical sciences began in the final years of the nineteenth century. Chapter 4 looks at the periodic table during the era of discoveries regarding atomic structure, radioactivity, and isotopes. The “chemistry of the invisible” challenged chemists’s ideas about atoms and elements, replacing their reliance on their senses and weights and measures with invisible rays “seen” through physical tools such as electrometers. This chapter shows that the periodic system was an important research tool for the chemists and physicists who investigated radioactivity and atomic structure. In turn, these discoveries had a great effect on the periodic system, replacing atomic weight with atomic number as its organizing principle, while at the same time bolstering its place as a fundamental theory of chemistry. By the start of World War I, the periodic system was well-established and its utility in research began to wane. Its pedagogical use, however, continued to increase as chemical educators worked to find ways to “fix” the deficiencies of Mendeleev’s table.

Chapter 5 follows the periodic table in the era of internationalism in the twentieth century. With the establishment of the International Union of Pure and Applied Chemistry, the periodic table gained a caretaker as the IUPAC worked to redetermine atomic weights and redefine the element. The IUPAC determined that it was too controversial to impose any restrictions on the use of a particular form, thus having little effect on the ever-growing number of periodic tables. This chapter demonstrates how firmly entrenched the periodic table had become in chemical education. As chemical educators grappled with the confusion wrought by the ever increasing number of visual representations used in textbooks and classrooms, the need for a standard form became apparent. The current standard form eventually was recognized as being the graphical representation best suited for pedagogical purposes and came to “reign supreme” over other forms in textbooks and on wall charts. It was chemical educators rather than chemical researchers or international chemical organizations that developed the current standard form of the periodic table.

**CHAPTER 2**  
**“GENERALISATIONS AND ESTABLISHED FACTS”:**  
**ORGANIZING THE ELEMENTS BEFORE 1869**

**Introduction**

The study of the history of chemistry shows that natural laws “do not originate suddenly in the head of a single individual,” the German chemist Albert Ladenburg told his audience. “It is only slowly that the fundamental ideas which underlie them mature, and that the requisite facts are ascertained by the labours of many; until, at last, the law common to them all is announced by some one, or often by several persons simultaneously.”<sup>68</sup> Such is the story of the periodic law. The basic chemical concepts which undergird it were slowly worked out over the course of the nineteenth century until a point was reached in which the concept of periodicity, the idea that something recurs at a regular interval, evolved and was used to understand the relationships between the elements and to organize them in a comprehensive fashion. The Russian chemist Dmitri Mendeleev stated, “The law of periodicity was ... the direct outcome of the stock of generalisations and established facts which had accumulated by the end of the decade 1860-1870.”<sup>69</sup>

---

<sup>68</sup> A. Ladenburg, *Lectures on the History of the Development of Chemistry since the Time of Lavoisier*, trans. by Leonard Dobbin from the 2<sup>nd</sup> German ed. (Edinburgh: The Alembic Club, 1900): 3-4,  
<https://books.google.com/books?vid=HARVARD:32044058223652>.

<sup>69</sup> Professor Mendeléeff, “The Periodic Law of the Chemical Elements,” *Journal of the Chemical Society. Transactions* 55 (1889): 639, doi:10.1039/CT8895500634.

Chemists in the early nineteenth-century were well aware that there was still much to learn. This was a point mentioned frequently in both their papers and textbooks. The Scottish chemist Thomas Thomson, in the first edition of his *A System of Chemistry*, used the phrases “as the science advances towards perfection” and “when the science reaches the highest point of perfection,” to indicate there was much still to be discovered about the elements.<sup>70</sup> Thirty years later, in a paper read before the Royal Society of London, Edward Turner concluded that analytic chemistry had not yet “attained that degree of perfection which can justify any one in finally asserting or denying” the validity of Prout’s hypothesis.<sup>71</sup> Another twenty years on, in 1853, British chemist John Hall Gladstone stated, “although we cannot now see the precise reason” why a particular relationship seemed to exist between the elements, leaving the audience with the hope that chemistry would at some point soon be able to provide the reason.<sup>72</sup> But in the mid-nineteenth century, they were not yet prepared to frame broad and satisfying explanations of the relationships between and among the elements.

One of the great preoccupations of chemists throughout the nineteenth century was the classification and organization of the elements. Early in the century, attention was drawn to small groups of elements with similar properties

---

<sup>70</sup> Thomas Thomson, *A System of Chemistry*, vol. 1 (Edinburgh, 1802), 386, <https://hdl.handle.net/2027/uc1.aa0001914969>.

<sup>71</sup> Edward Turner, “Experimental Researches on Atomic Weights,” *Philosophical Transactions of the Royal Society of London* 123 (1833): 544, <http://www.jstor.org/stable/108005>.

<sup>72</sup> J. H. Gladstone, “On the Relations Between the Atomic Weights of Analogous Elements,” *Philosophical Magazine*, 4<sup>th</sup> ser., 5 (1853): 320, <https://hdl.handle.net/2027/uc1.31822016397317?urlappend=%3Bseq=337>.

whose atomic weights had a mathematical relationship. Philosophical ideas related to the unity of matter were also revived by the discovery of these mathematical relationships. Atomic weight, which had become an important characteristic of elements due to the acceptance of chemical atomic theory, became a research area of great interest as chemists worked not only to improve the calculation of atomic weight but to find more relationships between similar elements and to prove the validity of philosophical hypotheses.

As this chapter shows, the research into atomic weight was of a practical nature. The creation of a new classification systems of the elements would be the result of experimental research, not merely hypothetical and speculative ideas. Chemists hoped to locate an underlying principle or characteristic that would provide the means for a comprehensive system. Such a system would be not only of practical use for the laboratory but fundamental to the teaching of chemistry. Existing classifications were unclear, causing difficulties and confusion for students. The complex relationship between research and pedagogy can be seen in instances in which researchers who were also educators published new schemes developed originally for the lecture hall. But some also began to advocate for their own systems in the textbooks they authored, rather than leaving discussion to the more traditional venues of scientific meetings and journals. By the end of the 1860s, chemistry had developed, through both experiment and pedagogy, “the stock of generalisations and established facts” necessary to create a comprehensive classification system for the elements.

## Elements and Atomic Weight

French chemist Lavoisier and British chemist John Dalton bookend the chemical revolution characterizing the end of the eighteenth and the beginning of the nineteenth centuries. Both emphasized the role of weights and measures in chemistry while further defining the concept of the element. As the American chemist Francis Preston Venable wrote in 1896, "Dalton's revival of the atomic hypothesis at the beginning of this century gave additional meaning and importance to Lavoisier's definition of the elements, and from that time we have these two ideas, element and atoms, forming the very basis of the science of chemistry."<sup>73</sup>

While Lavoisier is famously recognized as having given the first list of elements that did not consist of a small number of familiar substances such as the classical elements of earth, air, fire, and water,<sup>74</sup> it was Dalton who gave the first list of atomic weights of the elements. The list was presented in a paper entitled, "On the Absorption of Gases By Water and Other Liquids," first read at the Manchester Literary and Philosophical Society in 1803 and then published in their *Memoirs* in 1805.<sup>75</sup> The determination of the atomic weights of the elements was integral to the development of Dalton's chemical atomic theory and in the following years atomic

---

<sup>73</sup> F. P. Venable, *The Development of the Periodic Law* (Easton, PA: Chemical Publishing Co., 1896): 13.

<sup>74</sup> Lavoisier, *Traité élémentaire de chimie* (Paris: Chez Cuchet, 1789), 192, <https://hdl.handle.net/2027/mdp.39015005319481>; Lavoisier, *Elements of Chemistry*, trans. by Robert Kerr (Edinburgh, 1790), 175, <https://hdl.handle.net/2027/gri.ark:/13960/t5v735k9h>.

<sup>75</sup> John Dalton, "On the Absorption of Gases By Water and Other Liquids," *Memoirs of the Literary and Philosophical Society of Manchester*, 2<sup>nd</sup> ser., 1 (1805): 271-287, <https://archive.org/details/memoirsofliterar01lite>. The table is on 287.



weight would come to be seen as a very important characteristic of the elements, if not the most important.

According to Dalton's theory, all matter was composed of atoms. He considered these atoms to be physical, that is, they were solid and indivisible, rather than theoretical constructs. Furthermore, he believed that "the ultimate particles of all homogenous bodies are perfectly alike in weight, figure, &c."<sup>76</sup> In other words, all atoms of a particular element are exactly the same, having exactly the same characteristics. Even when elements combine to make other substances, such as hydrogen and oxygen combining to form water, the atoms of each element retain their original characteristics. As a consequence of these assumptions, the historian William H. Brock wrote, Dalton "intimately bound his kind of atomism to the question of how elements were to be defined."

Dalton "fix[ed] a determinable property to [his atoms], that of relative atomic weight."<sup>77</sup> The weight of an atom of each element (i.e., its atomic weight), then, was extremely important. The operating definition of an element, as given by Lavoisier in 1788, was somewhat vague: simple bodies were those that were "the last point which analysis is capable of reaching." However, there was a caveat:

since these principles cannot be separated, or rather since we have not hitherto discovered the means of separating them, they act as regard to us as simple substances, and we ought never to suppose them compounded until experiment and observation has proven them to be so.<sup>78</sup>

---

<sup>76</sup> John Dalton, *A New System of Chemical Philosophy*, Part 1 (Manchester: R. Bickerstaff, 1808), 143. <https://hdl.handle.net/2027/mdp.39015078143743>.

<sup>77</sup> William H. Brock, *The Norton History of Chemistry* (New York: W. W. Norton & Company, 1993), 136.

<sup>78</sup> Lavoisier, *Elements of Chemistry*, xxiv; Lavoisier, *Traité élémentaire de chimie*, xvii-xviii. This is essentially the same definition that had been in use for decades, although generally only earth, air, fire, and water were considered to be elements;

Dalton's atomic theory provided all elements with a particular characteristic, a unique weight, that chemists could utilize in determining if a substance was simple and could not be decomposed further. A century later, Venable described the determination of atomic weight as a "test for the elemental character."<sup>79</sup>

In his 1803 paper, Dalton stated, "An enquiry into the relative weights of the ultimate particles of bodies is a subject, as far as I know, entirely new."<sup>80</sup> It did not remain a new subject for long. After the publication of Dalton's *New System of Chemical Philosophy*, chemists began to turn their attention to the determination of the atomic weights of the elements. Many chemists were wary of accepting Dalton's premise that atoms were physical entities and preferred to consider atoms as theoretical constructs. While some used the term atomic weight, many used alternative terms such as combining weights and equivalent weights. Some of these terms were also used to convey other, albeit related, meanings, and it was sometimes difficult to determine what a particular chemist in a particular text meant.

The multiple terms for and understandings of atoms and weights did not get harmonized until the years following the Karlsruhe Congress, but despite the confusion, the determination of atomic weights was an important research field during the nineteenth century. More accurate atomic weights were not the only

---

see, for example, the entry for Elements in Pierre Joseph Macquer, *A Dictionary of Chemistry*, 2<sup>nd</sup> ed. (London: 1777), vol. 1, <https://archive.org/details/dictionaryofchem01macq>.

<sup>79</sup> F. P. Venable, "The Definition of the Element," *Science*, n.s., 10 (1899): 276, <http://www.jstor.org/stable/1626614>.

<sup>80</sup> Dalton, "On the Absorption," 286.

result. Chemists also used this research to consider the nature of the elements themselves and to investigate the many relationships between them. In doing so, they created “the stock of generalisations and established facts” that Mendeleev claimed resulted in the development of the periodic law.

### **Prout’s Hypothesis and the Unity of Matter**

In a paper read at the 1832 meeting of the British Association for the Advancement of Science,<sup>81</sup> Edward Turner stated:

The adoption by British chemists of the opinion that simple atomic weights are multiples by whole numbers of the atomic weight of hydrogen, and the experimental contradiction given to that opinion by so distinguished an analyst as Berzelius, induced me about three years ago to undertake an inquiry into the subject.<sup>82</sup>

Turner was far from the only chemist who undertook to prove, or disprove, this idea. In fact, so many chemists had done so that as early as 1826, Andrew Ure was lamenting that this kind of inquiry, which “can hardly be deemed an intellectual operation, should have usurped, to too great a degree, in some recent publications, the place of researches into the *powers* that modify matter.”<sup>83</sup> Despite Ure’s lament,

---

<sup>81</sup> Only an account of Turner’s paper was published in the *Report of the BA meeting; E. Turner, “On Atomic Weights,”* in *Report of the First and Second Meetings of the British Association for the Advancement of Science at York in 1831 and at Oxford in 1832*, Second ed. (London: John Murray, 1835), 576, <https://books.google.com/books?id=S3pMAQAAMAAJ>.

<sup>82</sup> Edward Turner, “On Some Atomic Weights,” *Philosophical Magazine*, 3<sup>rd</sup> ser., 1 (1832): 109, <https://books.google.com/books?id=JW8qAAAAYAAJ>.

<sup>83</sup> Andrew Ure, “An Attempt to Establish the First Principles of Chemistry By Experiment,” review of *An Attempt to Establish the First Principles of Chemistry By Experiment*, by Thomas Thomson, *Quarterly Journal of Science, Literature, and the Arts* 10 (1826): 113, <https://hdl.handle.net/2027/hvd.32044106374762?urlappend=%3Bseq=131>. No author is given in the review but David Knight attributes it to Ure; see *Classical Scientific Papers: Chemistry, Second Series* (London: Mills & Boon Limited, 1970), 6.

most historians of chemistry, as well as many chemists in the late nineteenth century, agree that the pursuit of proving, or disproving, this idea known as Prout's hypothesis was an important factor in the development of the periodic law.<sup>84</sup>

The English physician and chemist William Prout first outlined his hypothesis in two anonymous papers published in 1815 and 1816.<sup>85</sup> Historian William Brock argued we should speak rather of Prout's hypotheses as there were two separate, albeit related, parts.<sup>86</sup> Both refer to the importance of the element hydrogen, in different though related ways. One hypothesis states that the atomic weights of the elements are whole multiples of the atomic weight of hydrogen. The other hypothesis argues that hydrogen is the first matter of the ancient Greeks, the material of which all the elements are composed. It is easy to see a connection between the two hypotheses – if the atomic weights of all elements are multiples of that of hydrogen, then couldn't it be said that they are all made of hydrogen? – but it is also easy to see why some chemists would reject one if not both of the hypotheses.

---

<sup>84</sup> For example, see Eric R. Scerri, *The Periodic Table: Its Story and Its Significance* (New York: Oxford University Press, 2007), 67-68, and J. W. Van Spronsen, *The Periodic System of Chemical Elements: A History of the First Hundred Years* (Amsterdam: Elsevier, 1969), 23-24, and Francis Preston Venable, *Development*, 11-12.

<sup>85</sup> [William Prout,] "On the Relations Between the Specific Gravities of Bodies in Their Gaseous State and the Weight of Their Atoms," *Annals of Philosophy* 6 (1815): 321-330, [https://hdl.handle.net/2027/uc1.\\$b526641?urlappend=%3Bseq=345](https://hdl.handle.net/2027/uc1.$b526641?urlappend=%3Bseq=345), and [William Prout,] "Correction of a Mistake in the Essay on the Relation Between the Specific Gravities of Bodies in Their Gaseous State and the Weights of Their Atoms," *Annals of Philosophy* 7 (1816): 111-113, [https://hdl.handle.net/2027/uc1.\\$b526642?urlappend=%3Bseq=143](https://hdl.handle.net/2027/uc1.$b526642?urlappend=%3Bseq=143). Thomas Thomson revealed Prout's authorship in an article in his *Annals of Philosophy* later in 1816.

<sup>86</sup> W. H. Brock, *From Protyle to Proton: William Prout and the Nature of Matter, 1785-1985* (Bristol: Adam Hilger Ltd, 1985), 92.

The idea of the unity of matter is an old one, harkening back to the ancient Greeks. It is also an idea that has never completely died out. There have been many flavors of it, some of which have suggested there was a single primary matter out of which everything is made, while others suggested there was a “very restricted diversity” of matter.<sup>87</sup> These ideas gained momentum during the nineteenth century, particularly with the veritable explosion in the number of new elements discovered. Lavoisier’s 1789 table of simple substances listed 28 elements; by 1830 the number of known elements had doubled to between 50 and 60.<sup>88</sup> Although this overwhelming increase did not bother all chemists, it did prompt many chemists to consider ancient ideas about the unity, or simplicity, of matter.

In the first edition of his *A System of Chemistry*, Thomas Thomson deciphered Lavoisier’s definition of an element for his readers. A simple substance was “nothing more than a body whose component parts are unknown,” but over time these simple bodies would be discovered to be compound bodies, and that resulting set of supposedly simple bodies would also be discovered to be compound, and so on. Eventually, “when the science reaches the highest point of perfection ... the number of simple substances will probably be much smaller than at present.” Thomson then referred to the ancient idea that there was a primary matter of which everything consisted. An intriguing idea, perhaps, but he warned that “the full

---

<sup>87</sup> See David M. Knight, *The Transcendental Part of Chemistry* (Folkstone: Dawson, 1978).

<sup>88</sup> Lavoisier, *Traité*, 192; Lavoisier, *Elements*, 175. The number varies by source as not all newly discovered elements were accepted as such by all chemists; J. F. W. Herschel, *A Preliminary Discourse on the Study of Natural Philosophy* (London, 1831), 302, <https://hdl.handle.net/2027/umn.319510009534720>.

demonstration of this theory is perhaps beyond the utmost stretch of human sagacity.”<sup>89</sup>

A decade later, in 1812, Humphry Davy, although himself responsible for the discovery of several new elements through the use of the Voltaic pile, argued that, “It is contrary to the usual order of things, that events so harmonious as those of the system of the earth, should depend on such diversified agents are supposed to exist in our artificial arrangements.” However, he continued, “there is reason to anticipate a great reduction in the number of the undecomposed bodies.”<sup>90</sup> Going further than Thomson’s vague belief that a smaller number of elemental bodies may exist, Davy suggested that, “hydrogen is the substance which approaches nearest to what the elements may be supposed to be. ... After hydrogen, oxygen partakes most of the elementary character.”<sup>91</sup> Three years later, Prout took Davy’s search for simplicity and determined that hydrogen was the primary matter of which all of the elements were made. Ultimately, according to this way of thinking, the number of undecomposed bodies, or elements, did not matter as they were all essentially hydrogen.

Unlike Thomson and Davy, John Herschel professed to not consider “the multiplication of so-considered elementary bodies” to be an “inconvenience.” There may, he wrote, be “one essential element out of which all matter is framed,” and “it

---

<sup>89</sup> Thomson, *A System of Chemistry*, 386.

<sup>90</sup> Humphry Davy, *The Collected Works of Sir Humphry Davy*, ed. John Davy, vol. 4 (London: Smith, Elder and Co., 1840), 42, <https://hdl.handle.net/2027/hvd.32044021235262>. Davy's “undecomposed bodies” are elements; he disliked the term element and refused to use it.

<sup>91</sup> Davy, *Collected Works*, 358-359.

would be indispensably necessary to be perfectly familiar with it.” However, the aim of chemistry was not to set out to find this essential element but to wait for it to be revealed through “the slow progress of enlarged views.”<sup>92</sup> On the other hand, and very contrary to Ure’s lament, Herschel regarded the other aspect of Prout’s hypothesis to be one that “opens views of such importance as to justify any degree of labour and pains in the verification” of what could possibly be a “law.”<sup>93</sup>

This other aspect, Prout’s other hypothesis, that atomic weights of the elements are whole number multiples of that of hydrogen, was also a point of contention. Prout tended to round his weights to the nearest whole number. This was a practice of some chemists for research but more particularly for pedagogical purposes – it was far easier for students to deal with whole numbers than fractions or decimals.<sup>94</sup> Others insisted that weights should always be published with decimals. Berzelius, who was widely considered to be a chemical authority in the first half of the nineteenth century, was critical of Prout’s practice of rounding his results up or down, seemingly depending on which was the best fit for his theory: “It seemed to him convenient and advantageous to science, that the atomic weights should be expressed by small numbers, and without fractions.” Berzelius could only

---

<sup>92</sup> Herschel, *Preliminary*, 304-305.

<sup>93</sup> Herschel, *Preliminary*, 307.

<sup>94</sup> Edward Turner stated his opinion on the matter before the Royal Society in 1833: “I grant most willingly, that a system of whole numbers, considered as moderate approximations, may, with advantage, be retained for the use of medical men, students, and manufacturers,” but decimals were required “as the strict representative of scientific truth”; Turner, “Experimental Researches,” 544.

conclude that, “The basis of Mr. Prout’s hypothesis, then, is the supposed inexactness of experiment.”<sup>95</sup>

Berzelius may have come down against Prout’s hypothesis, but that did not stop chemists from continuing their research on the matter. In 1841, the French chemists Jean Baptiste Dumas and Jean Servais Stas presented a lengthy account of their research on the atomic weight of carbon. Describing Prout as a “skillful chemist,” they concluded that “[o]ur experiences fully confirm” his hypothesis that the atomic weights of the elements are whole number multiples of that of hydrogen.<sup>96</sup> Dumas would continue to be an avid supporter of Prout’s hypothesis, modifying it to make it work as more advanced analytical techniques and new instruments improved the accuracy of the determination of atomic weights.<sup>97</sup> Stas, however, would eventually change his mind.

During the 1850s, Stas undertook extensive and exacting research into the atomic weight of several elements, including silver. He admitted that when he began his work, he “had an almost absolute confidence in the accuracy of the principle of Prout.”<sup>98</sup> By the time he had finished, Stas had come to the conclusion

---

<sup>95</sup> Jac. Berzelius, “On the Hypothesis of Mr. Prout, With Regard to Atomic Weights,” *American Journal of Science*, 1st ser., 48 (1845): 369,

<https://hdl.handle.net/2027/inu.32000007831862?urlappend=%3Bseq=393>.

<sup>96</sup> J. Dumas and Stas, “Sur le véritable poids atomique du carbone,” *Annales de Chimie et de Physique*, 3<sup>rd</sup> ser., 1 (1841): 24,

<https://hdl.handle.net/2027/msu.31293024223673?urlappend=%3Bseq=9>; “Nos expériences confirment pleinement cette remarque...”.

<sup>97</sup> J. Dumas, “Mémoire sur les Équivalents des Corps Simples,” *Annales de Chimie et de Physique*, 3<sup>rd</sup> ser., 55 (1859): 129-210,

<https://hdl.handle.net/2027/uva.x002489063?urlappend=%3Bseq=133>.

<sup>98</sup> J.-S. Stas, “Recherches sur les rapports réciproques des poids atomiques,” *Bulletin de l’Académie Royale des Sciences (Belgique)*, 2<sup>nd</sup> ser., 10 (1860): 211,



that Prout's hypothesis was an illusion, a hypothesis that was contradicted by experimental evidence, and that there was no primary matter out of which all the elements were made.<sup>99</sup> Despite what may have seemed rather definitive evidence that Prout's hypothesis was not valid, others continued to believe, most notably Charles Marignac,<sup>100</sup> who committed what Venable, an early chronicler of the periodic law, called the "fatal error of rounding off fractions into whole numbers." This was, he pointed out, "the very thing which mislead [*sic*] Prout at the beginning and with him there was far more excuse for it."<sup>101</sup>

Venable describes Marignac's dispute over Stas's latest determinations as "[t]he last serious conflict over [Prout's] hypothesis," before the development of the periodic law.<sup>102</sup> Experimental evidence over the course of several decades, from Berzelius to Turner to Stas, caused great doubts among many. By the time of the Karlsruhe Congress, it seemed as if both aspects of Prout's hypothesis had largely been shown to be incorrect. Given that the idea of the unity of matter, of a primary material out of which everything is made, had been in existence in one form or another since antiquity, Prout's hypothesis did not completely die and, after the initial development of the periodic law, it would be revived once more. But aside from renewing interest in the idea of the unity of matter, investigations into Prout's

---

<https://hdl.handle.net/2027/pst.000060106681?urlappend=%3Bseq=222>; "Je le dis hautement..."

<sup>99</sup> Stas, "Recherches sur les rapports...", 212.

<sup>100</sup> C. Marignac, "Recherches sur les Rapports Réciproques des les Poids Atomique par M. J.-S. Stas," *Archives des Sciences Physiques et Naturelles*, 2<sup>nd</sup> ser., 9 (1870): 97-107, <https://hdl.handle.net/2027/njp.32101033964915?urlappend=%3Bseq=463>.

<sup>101</sup> Venable, *Development*, 64.

<sup>102</sup> Venable, *Development*, 63.

hypothesis also revealed that there were mathematical, or numerical, relationships between specific groups of elements.

### **Mathematical Relationships Between the Elements**

Even as he was disparaging Prout's hypothesis in the pages of the *American Journal of Science*, Berzelius observed:

Among the atomic weights there are those which are apparently equal, and others which approximate quite near to being double of one another in weight – from which it is probable that there is between them a certain relation.... But this is a new question, to be discussed only after farther [*sic*] investigation.<sup>103</sup>

He was far from the first chemist to notice such relationships. Indeed, the decades before 1870 are characterized by chemists searching for numerical relationships between the atomic weights of the elements. This so-called "craze" had its roots in the 1817 discovery by German chemist Johann Döbereiner that there were several sets of three elements that shared similar chemical properties, the atomic weight of the central element being the mean of the other two elements in the group.<sup>104</sup> These became known as triads. However, in the following decades little work was done on the concept of numerical relationships between the elements, in part because of the difficulties in determining accurate atomic weights.

---

<sup>103</sup> Berzelius, "On the Hypothesis...", 372.

<sup>104</sup> The first published mention of Döbereiner's work on triads appeared in a communication by Hofrath Wurzer on new research; see "Auszug eines Briefes von Hofrath Wurzer, Prof. der Chemie zu Marzburg," *Annalen der Physik* 56 (1817): 331-334, <https://hdl.handle.net/2027/uc1.b4433520?urlappend=%3Bseq=349>. Döbereiner published a full paper outlining his system of triads in 1829; see "Versuch zu einer Gruppierung der elementaren Stoffe nach ihrer Analogie," *Annalen der Physik* 91 (1829): 301-307, <https://hdl.handle.net/2027/uiug.30112053427693?urlappend=%3Bseq=317>.

By 1850, partially due to the work done on (dis)proving Prout's hypothesis, the atomic weights of the elements had become more accurate. At the British Association meeting at Ipswich in 1851, Dumas gave a lecture on "Observations on atomic volumes and atomic weights, with considerations on the probability that certain bodies now considered as elementary may be decomposed."<sup>105</sup> Dumas drew attention to groups of triads, noting that not only did the middle element of the triad have an atomic weight of the mean of the elements on either side, but it also had "most of its qualities intermediate with the properties of its extremes." Dumas then suggested that perhaps the intermediate, or middle, element was actually composed of the elements on either side of it, raising the possibility of transmutation.<sup>106</sup> For example, with the triad chlorine, bromine, and iodine, "if we could by any means cause the union of half an atom of chlorine with half an atom of iodine, we might hope to get, to form, to create, an atom of bromine!"<sup>107</sup>

This transmutation idea may seem as if it was harkening back to the alchemist's dream of transmuting lead into gold, and indeed several chemists did make such a comparison. But Dumas was drawing attention to something that had already been noticed about particular sets of elements, namely that they seemed to

---

<sup>105</sup> Dumas's lecture is not mentioned in the *BA Report* for the 1851 meeting. Reports in chemical journals provide the only evidence of its content; it was, apparently, given without notes or previously prepared diagrams. See "Extracts from the Proceedings of the Twenty-first Meeting of the British Association, Held at Ipswich, July 2," *American Journal of Science and Arts*, 2<sup>nd</sup> ser., 12 (1851): 275-277, <https://hdl.handle.net/2027/umn.31951000569248x?urlappend=%3Bseq=279>, and Dumas, "On the Transmutation of Bodies," *Chemical Record and Drug Price Current* 1 (1851): 5-6, <https://hdl.handle.net/2027/hvd.hxf6e?urlappend=%3Bseq=17>.

<sup>106</sup> "Extracts from the Proceedings," 276.

<sup>107</sup> Dumas, "On the Transmutation," 5.

have similar properties. Today, we recognize chlorine, bromine, and iodine as being in the same group of elements, group 17. The elements in a group are analogous, having similar properties, and can often be substituted, one for the other, when making compounds. Despite the language of transmutation, Dumas drew an important connection between the atomic weights of elements and their characteristics.

Dumas's lecture was well-received and engendered much discussion at the BA meeting. The account in the *Chemical Record* concluded:

Wherever viewed, chemistry is full of the startling coincidences now introduced to our notice for the first time by M. Dumas; and, whatever may be the difference of opinion as to the speculative notions of the philosopher, there can be no doubt that he has opened a wide store of chemical treasure.<sup>108</sup>

Indeed, the following year, Michael Faraday gave a lecture at the Royal Institution on chlorine, bromine, and iodine, in which he described Dumas's ideas as "beautiful speculations ... which may possibly be the harbinger of a new law."<sup>109</sup> Other chemists quickly took up the challenge of making connections between the elements.

In 1852, P. Kremers reported the first of his findings regarding the mathematical relationships between the atomic weights of groups of elements. He noticed that among a group of analogous non-metals, including oxygen, sulfur, titanium, lead, and selenium, there is a regular difference of eight between their

---

<sup>108</sup> Dumas, "On the Transmutation," 6.

<sup>109</sup> Faraday, *The Subject Matter of a Course of Six Lectures on the Non-Metallic Elements*, (London: Longman, Brown, Green, and Longmans, 1853), 158. <https://hdl.handle.net/2027/mdp.39015065709852>.

atomic weights when arranged in order by weight. The atomic weights of the metals falling between these non-metals had a regular difference of four from each non-metal beside it. For example, magnesium was four more than oxygen and four less than sulfur.<sup>110</sup> Six years later, he reported that the known triads could be further grouped together into sets of three, comprising nine elements in total (Fig. 1).<sup>111</sup> If you line up the three triads Li-Na-K, Mg-Zn-Cd, and Ca-Sr-Ba in three rows, one triad in each row, the atomic weights of the first row are roughly the same as the atomic weights of the first column (i.e., Li, Na, K, and Li, Mg, Ca). Kremers found eight sets of these conjugated triads.<sup>112</sup>

<b>Li</b>	<b>Na</b>	<b>K</b>
<b>Mg</b>	<b>Zn</b>	<b>Cd</b>
<b>Ca</b>	<b>Sr</b>	<b>Ba</b>

**Figure 2.1: One of Kremer's Conjugated Triads (1858)**

<sup>110</sup> P. Kremers, "Ueber den Zusammenhang des specifischen Gewichtes chemischer Verbindungen mit ihrer Auflöslichkeit in Wasser, nebst einer daraus abgeleiteten Theorie der Wahlverwandtschaften," *Annalen der Physik und Chemie* 85 (1852): 37-57, 246-262, doi:10.1002/andp.18521610105, doi:10.1002/andp.18521610210.

<sup>111</sup> P. Kremers, "Ueber die Modification der mittleren Löslichkeit einiger Salzatome und des mittleren Volums dieser Lösungen," *Annalen der Physik und Chemie* 104 (1858): 134,

<https://hdl.handle.net/2027/umn.31951d00326543q?urlappend=%3Bseq=149>.

<sup>112</sup> P. Kremers, "Ueber die Modification der mittleren Löslichkeit einiger Salzatome und des mittleren Volums dieser Lösungen," *Annalen der Physik und Chemie* 103 (1858): 57-68, 104 (1858): 133-162,

<https://hdl.handle.net/2027/umn.31951d00326542s?urlappend=%3Bseq=73>,

<https://hdl.handle.net/2027/umn.31951d00326543q?urlappend=%3Bseq=149>.

While Kremers was attempting to find relationships between groups of triads, John Hall Gladstone reviewed the evidence for himself. He began in a somewhat different fashion, by arranging all of the elements in order by their atomic weight; according to Venable, he was the first to do so.<sup>113</sup> Not seeing any obvious relationships, Gladstone then arranged the elements into groups according to their chemical relationships, as shown in Gmelin's *Handbook of Chemistry* (Fig. 2).<sup>114</sup> After replacing the element symbols with their weights, he discerned some relationships, but they were largely the same triads that had already been noted by others. "Why should this numerical relation always give us triads?," he wondered. He could offer only speculations but he did assert that it was "against all probability that, by mere chance, whenever, with one exception, close analogy of properties exist, there exists also numerical relationship."<sup>115</sup>

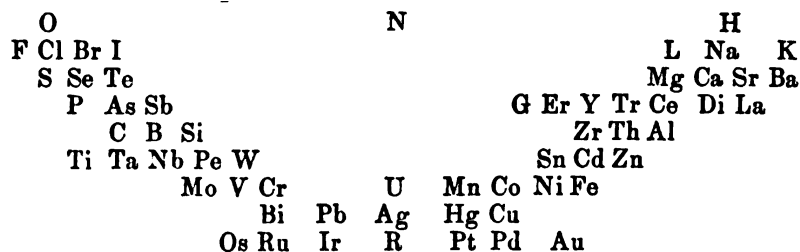

**Figure 2.2: Gmelin's Groups (1849)**

<sup>113</sup> Venable, *Development*, 39.

<sup>114</sup> Gmelin arranged the elements "in groups according to their physical and chemical relations," and noted that "[t]he only way of making a satisfactory arrangement would be to dispose the elements, not on a plane surface, but within an envelope of three dimensions." Leopold Gmelin, *Hand-Book of Chemistry*, vol. 2, trans. Henry Watts (London, 1849), 1, <https://hdl.handle.net/2027/mdp.39015067141054>.

<sup>115</sup> Gladstone, "On the Relations," 319, 320.

The American chemist Josiah P. Cooke, Jr., was also looking at a larger picture than mere triads – he was looking for a classification system for the elements. The classification most commonly used by chemists was a seemingly simple one, elements were either metalloids (non-metallic elements) or they were metals. This system was based on only one set of properties and sometimes caused confusion as a handful of elements were counted as metals by one chemist but as metalloids by another. As Gmelin noted in his *Handbook* that, “[n]o exact line of demarcation can be drawn between metals and metalloids,”<sup>116</sup> Cooke, too, found such a system somewhat ridiculous: “For a zoölogist to separate the ostrich from the class of birds because it cannot fly, would not be more absurd, than it is for a chemist to separate two essentially allied elements, because one has a metallic lustre and the other has not.”<sup>117</sup> Just as biologists and zoologists categorized animals or plants based on more than its appearance, chemists should not rely only on appearance but rather other characteristics. Cooke realized that a “correct” classification system would need to be based on a “fundamental property common to all the elements, the law of whose variation was known.” Such a property was, however, yet unknown.<sup>118</sup>

In his search for a better classification than a not-so-simple divide between metals and metalloids, Cooke had found that, “[a]ll the elements may be classified into six series, in each of which this number is different, and may be said to

---

<sup>116</sup> Gmelin, *Handbook*, 1.

<sup>117</sup> Josiah P. Cooke, “The Numerical Relation Between the Atomic Weights, With Some Thoughts on the Classification of the Chemical Elements,” *Memoirs of the American Academy of Arts and Sciences*, new ser., 5 (1855): 237-238, <http://www.jstor.org/stable/25058181>.

<sup>118</sup> Cooke, “Numerical Relation,” 238.

characterize its series.”<sup>119</sup> The elements in each series formed similar compounds and produced similar reactions, they had the same crystalline forms, and “many of their properties vary in a regular manner as we descend in the series.”<sup>120</sup> Cooke had developed a “simple algebraic formula” to express atomic weight:  $a+nb$ . The formula for specific gravity was  $pa+npb$ . In each series,  $p$  represented a relationship between atomic weight and specific gravity, so that, for example, in the Nine Series where  $p=1$  the specific gravities of the elements were the same at the atomic weights, whereas in the Six Series where  $p=2$  the specific gravities were twice the atomic weights (Fig. 3).<sup>121</sup>

THE NINE SERIES.			THE SIX SERIES.		
Sp. Gr. = 1. At. W. = 1.			Sp. Gr. = 2. At. W. = 2.		
Sp. Gr. = $8 + n 9$ .			Sp. Gr. = $16 + n 12$ .		
Names.	SPECIFIC GRAVITIES.		Names.	SPECIFIC GRAVITIES.	
	Theoret.	Observed.		Theoret.	Observed.
Oxygen	8	16	Oxygen	16	16
Fluorine	17		Nitrogen	28	14
Cyanogen	26	26	Phosphorus	64	64
Chlorine	35	35.5	Arsenic	148	150
Bromine	80	78	Antimony	256	
Iodine	125	126	Bismuth	412	

**Figure 2.3: Two of Cooke's Series (1855)**

Like Cooke, the British chemist William Odling was not keen on the usual classifications that were in use:

... although the groupings of the elements are as real and certain as the natural families of plants and animals, yet we find constantly, in our systematic treatises, that bodies manifesting the strongest analogies are

<sup>119</sup> Cooke, “Numerical Relation,” 235-236.

<sup>120</sup> Cooke, “Numerical Relation,” 239.

<sup>121</sup> Cooke, “Numerical Relation,” 252, 253.



widely separated from one another, while bodies belonging to very different groups are conventionally associated.<sup>122</sup>

While Cooke hoped to show that “[t]he doctrine of triads is ... a partial view of this subject,”<sup>123</sup> Odling took triads as the starting point for his classification, arguing that, “[i]n attempting a natural classification [of the elements, we must have regard, though not an equal regard, to all the properties they manifest.”<sup>124</sup> He arranged the elements into 13 groups, each of which consisted of one of the recognized triads, generally with the addition of one or more elements that Odling believed shared important properties. Unlike Cooke, Odling did not develop an algebraic formula for his classification, rather he emphasized the use of “fundamental” characteristics rather than “superficial” ones.<sup>125</sup>

Most of the chemists investigating the relationships between the elements agreed that there must be some underlying law that applied to the relationships. Statistically, as Gladstone noted, it was highly unlikely that the mathematical relationships between the atomic weights of the elements were entirely by chance. Cooke believed it was time to look past mere triads. Odling suggested that while “certain elements have certain properties in common is now a time-honoured doctrine in chemical science,” it was time to “investigate the extent of the association” and consider it “as a means of classification.”<sup>126</sup> It was time to “be

---

<sup>122</sup> William Odling, “On the Natural Groupings of the Elements,” *Philosophical Magazine*, 4<sup>th</sup> ser., 13 (1857): 424, <https://hdl.handle.net/2027/njp.32101076464641?urlappend=%3Bseq=441>.

<sup>123</sup> Cooke, “Numerical Relation,” 235.

<sup>124</sup> Odling, “On the natural,” 424.

<sup>125</sup> Odling, “On the natural,” 425.

<sup>126</sup> Odling, “On the Natural Groupings,” 423-424.

guided by the totality of their characters,” rather than by only one,<sup>127</sup> or perhaps even only by mathematics.

### **Visualizing Elemental Relationships**

Venable stated that by the time of the Karlsruhe Congress in 1860, “[t]he craze for searching out regularities ... seems to have largely subsided.” There is at this point, “mainly a striving after classification, not disjointed triads, nor unconnected families, but a continuous series of some sort.”<sup>128</sup> It is clear that in the mid- to late-1850s Cooke and Odling, among others, were already striving towards a classification system for all of the elements rather than finding new triads or, like Kremers, creating sets of conjugated triads. Another change that also occurred after 1860 is the increased use of tables to illustrate the process of developing classifications and the classifications themselves.

This change applies to all scientists, not just to chemists. According to communications specialists Alan G. Gross, Joseph E. Harmon, and Michael Reidy, as the nineteenth century progressed, papers shifted from description to explanation, which increased the complexity of arguments as well as the number of visualizations. By the end of the nineteenth century, the number of tables and figures per paper had risen considerably and was close to that of articles in the twentieth century. Visuals were used to embody and suggest explanations, support

---

<sup>127</sup> Odling, “On the Natural Groupings,” 424.

<sup>128</sup> Venable, *Development*, 65.

theories, depict law-like relationships, support modifications to laws, and suggest new theoretical directions and research programs.<sup>129</sup>

This trend can be seen in Odling's papers regarding the classification of the elements. In his 1857 paper on the natural groupings of the elements, there was a significant amount of text with quite a bit of chemical and mathematical formulae, but few tables. Seven years later, however, his paper on the proportional numbers of the elements was about equal in terms of text and tables and less heavy on the formulae.<sup>130</sup> The tables were used to illustrate different relationships that Odling had found between the elements based on their atomic weights. They served to take the place of explanations that previously were made with words. The tables were preceded by phrases such as, "as shown below," and "as shown in the following table," leaving the tables to take the place of text. But as other phrases such as, "is shown still more strikingly below," and "In looking over the above tables, we can scarcely help noticing," would seem to indicate that seeing the relationships made a stronger impact than merely reading about them. A table, if not worth a thousand words, could take the place of dozens and make a point more clearly.

Having such visual impacts was also useful in illustrating where nothing currently was, or where something could possibly be. In several of his tables, Odling utilized the right-hand quotation mark (") to show where currently undiscovered

---

<sup>129</sup> Alan G. Gross, Joseph E. Harmon, and Michael Reidy, *Communicating Science: The Scientific Article from the 17<sup>th</sup> Century to the Present* (New York: Oxford University Press, 2002), chapter 7, esp. 148-156.

<sup>130</sup> William Odling, "On the Proportional Numbers of the Elements," *Quarterly Journal of Science* 1 (1864): 642-648, <https://hdl.handle.net/2027/mdp.39015013721371?urlappend=%3Bseq=694>.

elements might be located. He noted that “the discovery of intermediate elements in the case of some or all of the other pairs, is not by any means improbable.”<sup>131</sup> If such elements were found, they would easily slide into his table. Echoing Gladstone’s conclusion a decade earlier, Odling concluded: “Doubtless some of the arithmetical relations exemplified in the foregoing tables and remarks are simply accidental; but taken altogether, they are too numerous and decided not to depend upon some hitherto unrecognized general law.”<sup>132</sup> It is telling that Odling seemed to give equal weight to tables and text in declaring there must be a law upon which the relationships between the elements is based.

The *vis tellurique* of the French geologist Alexandre-Émile Béguyer de Chancourtois is a case in which seeing the relationships as opposed to reading about them made all the difference. In 1862, de Chancourtois presented a series of papers before the French Académie des Sciences on the natural classification of the elements he had developed.<sup>133</sup> This classification was represented in three

---

<sup>131</sup> Odling, “On the Proportional,” 644.

<sup>132</sup> Odling, “On the Proportional,” 648.

<sup>133</sup> Béguyer de Chancourtois, “Mémoire sur un classement naturel des corps simple ou radicaux appelé *vis tellurique*,” *Comptes Rendus Hebdomadaires des Séances de l’Académie des Sciences* 54 (1862): 757-761, <https://hdl.handle.net/2027/uc1.31822009518911?urlappend=%3Bseq=763>; “Sur un classement des corps simples ou radicaux appelé *vis tellurique*: addition au Mémoire présenté à la séance du 7 avril,” *Comptes Rendus Hebdomadaires des Séances de l’Académie des Sciences* 54 (1862): 840-843, <https://hdl.handle.net/2027/uc1.31822009518911?urlappend=%3Bseq=846>; “Sur un classement des corps simples ou radicaux appelé *vis tellurique* – Addition au Mémoire présenté à la séance du 7 avril,” *Comptes Rendus Hebdomadaires des Séances de l’Académie des Sciences* 54 (1862): 967-971, <https://hdl.handle.net/2027/uc1.31822009518911?urlappend=%3Bseq=973>; “Tableau du classement naturel des corps simples, dit *vis tellurique*,” *Comptes Rendus Hebdomadaires des Séances de l’Académie des Sciences* 55 (1862): 600-601, <https://hdl.handle.net/2027/uc1.31822009249673?urlappend=%3Bseq=606>.

dimensions as a cylinder, meant to be rotated on a circular base. The elements were placed on the cylinder such that they formed a helix, which he called the *vis tellurique*, translated variously as the telluric screw or telluric helix.<sup>134</sup> Chancourtois arranged the elements in order of their atomic weight (Fig. 4).<sup>135</sup> Unlike Gladstone, who had done the same in 1853 and not seen anything of note, Chancourtois came to the conclusion that “[t]he properties of the bodies are the properties of the numbers.”<sup>136</sup> In essence, Chancourtois tied the properties of an element to its atomic weight.

This insight should have attracted at least some attention from chemists, particularly as it would seem to fulfill the function of Cooke’s as-yet-unknown “fundamental property common to all the elements.” However, Chancourtois’s classification received little notice. Twenty-five years later, the British chemist P. J. Hartog blamed this on the fact that Chancourtois’s “style was heavy and at times obscure,” leaving his ideas to be “presented in a way most unattractive to chemists.”<sup>137</sup> French chemists Boisbaudran and Lapparent also referred to

---

<sup>134</sup> The library of the École des mines de Paris, where Chancourtois was a professor of geology, has a copy of the *vis tellurique*; it can be seen on their web site at [https://patrimoine.mines-paristech.fr/document/Vis\\_tellurique](https://patrimoine.mines-paristech.fr/document/Vis_tellurique).

<sup>135</sup> Lecoq de Boisbaudran, et A. de Lapparent, “Sur une réclamation de priorité en faveur de M. de Chancourtois, relativement aux relations numériques des poids atomiques,” *Comptes Rendus Hebdomadaires des Séances de l’Académie des Sciences* 112 (1891): 80,

<https://hdl.handle.net/2027/uc1.31822009517608?urlappend=%3Bseq=85>.

<sup>136</sup> Béguyer de Chancourtois, “Suite du Mémoire de la vis tellurique, du 7 avril 1860, adressé à propos du thallium,” *Comptes Rendus Hebdomadaires des Séances de l’Académie des Sciences* 56 (1863): 482, <https://hdl.handle.net/2027/uc1.c080928393?urlappend=%3Bseq=483>; “Les propriétés des corps sont les propriétés des nombres.”

<sup>137</sup> P. J. Hartog, “A First Foreshadowing of the Periodic Law,” *Nature* 41 (1889): 188, doi:10.1038/041186a0

Chancourtois's writing style as a reason for the neglect of his *vis tellurique*, but they also blamed the fact that a copy of the helix was not included in the *Comptes Rendus*, although he had presented the Académie with a copy in October 1862, and that the pamphlet he produced in 1863<sup>138</sup> was not widely distributed.<sup>139</sup> Hartog claimed the visual representation of Chancourtois's helix to be "absolutely essential to the comprehension" of it.<sup>140</sup>

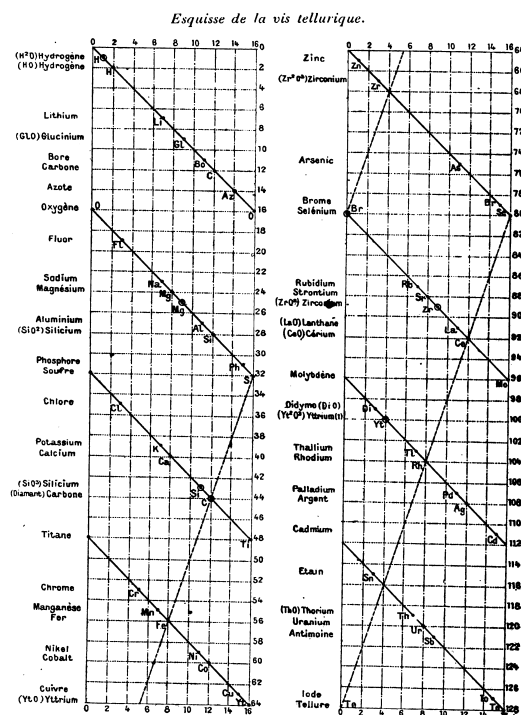

Figure 2.4: Representation of Chancourtois's *vis tellurique* (1862)

<sup>138</sup> A. E. Béguyer de Chancourtois, *Vis Tellurique: Classement naturel des corps simples ou radicaux, obtenu au moyen d'un système de classification hélicoïdal et numérique* (Paris: Mallet-Bachelier, 1863).

<sup>139</sup> Boisbaudran and Lapparent, "Sur une réclamation," 81; English translation, "A Reclamation of Priority on Behalf of M. de Chancourtois Referring to the Numerical Relations of the Atomic Weights," *Chemical News* 63 (1891): 52, <https://hdl.handle.net/2027/nyp.33433062748128?urlappend=%3Bseq=59>.

<sup>140</sup> Hartog, "First Foreshadowing," 186.

If the visual representation of the *vis tellurique* was so essential to its understanding, why was it not printed in the *Comptes Rendus* with one of Chancourtois's papers? The chemist and historian J. W. Van Spronsen stated that its "presentation in print involved great technical difficulties."<sup>141</sup> It would have required a separate plate and, more likely because of the size of the *vis tellurique*, a fold-out plate at that. Journals tended to keep such plates to a minimum as it increased both publication time and cost. By privately printing a pamphlet, Chancourtois was able to include as much text and as many representations as he could afford. In fact, his pamphlet contained color reproductions of his system, which was not the norm for any scientific journal of the time.

Another chemist who resorted to private publication for the fullest explanation of his classification scheme was Gustavus Detlef Hinrichs. Like Chancourtois, Hinrichs's writing was considered difficult to decipher.<sup>142</sup> Another difficulty for readers was that his system was based on an extreme form of Pythagoreanism.<sup>143</sup> But the central concept – and the basis for the atomic weights

---

<sup>141</sup> Van Spronsen, *The Periodic System*, 100.

<sup>142</sup> Carl Zapffe described Hinrichs as dressing his ideas "with multilingual ostentation," and George Kauffman noted that "Hinrichs was an adept linguist and polyglot, [with] a tendency to coin excessively new words, especially from the Greek." See Carl A. Zapffe, "Gustavus Hinrichs, Precursor of Mendeleev," *Isis* 60 (1969): 464, <http://www.jstor.org/stable/229106>, and George B. Kauffman, "American Forerunners of the Periodic Law," *Journal of Chemical Education* 46 (1969): 132, doi:10.1021/ed046p128.

<sup>143</sup> Scerri, *The Periodic Table*, 87. Pythagorean principles were not new to the study of relationships between the elements, and Benfey considered Chancourtois and Hinrichs to be "very Pythagorean pioneers of element classification"; O. Theodor Benfey, "Precursors and Cocusors of the Mendeleev Table: The Pythagorean Spirit in Element Classification," *Bulletin for the History of Chemistry* 13-14 (1992-1993): 66, [http://www.scs.illinois.edu/~mainzv/HIST/bulletin\\_open\\_access/bull-index.php](http://www.scs.illinois.edu/~mainzv/HIST/bulletin_open_access/bull-index.php).

he used – was the primary matter that Hinrichs referred to as pantogen, the atoms of which (panatoms) combined in geometrical ways to create the elements. In an 1866 paper, Hinrichs promised that a series of papers would be forthcoming which detailed “the properties of the chemical elements as functions of their atomic weights,”<sup>144</sup> an idea similar to that of Chancourtois. This series of papers was never published, but the following year he explained his classification system for the elements in his pamphlet *Programme der atomechanik oder die chemie eine mechanik der panatome*, referred to more frequently as his *Atomechanik* or *Atomechanics*.<sup>145</sup>

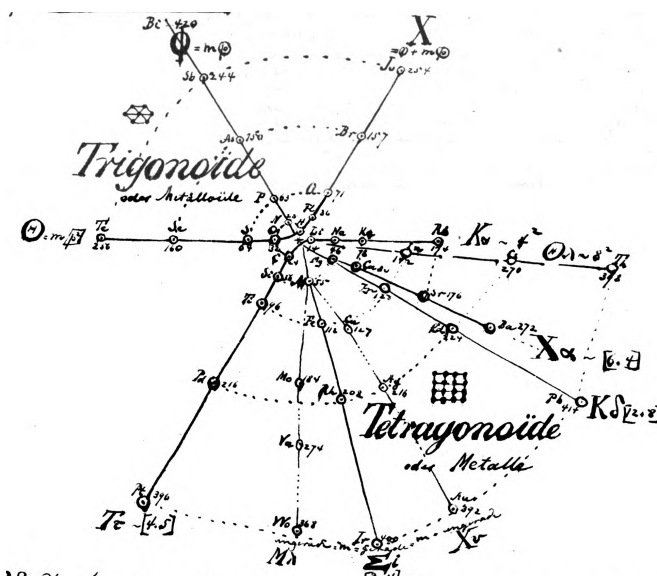

**Figure 2.5: Hinrichs's Spiral (1867)**

<sup>144</sup> Gustavus Hinrichs, “On the Spectra and Composition of the Elements,” *American Journal of Science and Arts*, 2<sup>nd</sup> ser., 42 (1866): 368, <https://biodiversitylibrary.org/page/36817782>.

<sup>145</sup> Gustav Hinrichs, *Programme der atomechanik oder die chemie eine mechanik der panatome* (Iowa City: Vereinigte Staaten, N.A., 1867), <https://hdl.handle.net/2027/mdp.39015018048952>.



One of the reasons for privately publishing was that the text was handwritten, in German, and not type-set. Also, the graphic representation of his classification system was in the form of a complex spiral,<sup>146</sup> containing many lines, dotted lines, and symbols, as well as text and numbers (Fig. 5).<sup>147</sup> None of Hinrichs's other articles or publications contained this representation, including the printed English-language version.<sup>148</sup> Rather, printed publications often included several tables that described the different groups of elements, as well as a tabular representation of his classification in place of the spiral found in his pamphlet.<sup>149</sup> In one such article he explained, "I now submit a tabular view of my classification.... The elements are here arranged in *columns* in order to facilitate the printing."<sup>150</sup> Although Hinrichs preferred the spiral representation, he was realistic enough to know that a tabular representation was necessary. Such a form was simply more practical, both for printing purposes but also for use in research and education.

---

<sup>146</sup> The reason Hinrichs used a spiral was not mentioned, though van Spronsen suggested that it was either "its resemblance to a natural form ... or for its similarity to the solar system." Hinrichs had a great interest in astronomy, so modeling his classification scheme after the solar system would be plausible. Van Spronsen, *The Periodic System*, 121.

<sup>147</sup> Hinrichs, *Programme der atomechanik*, 9.

<sup>148</sup> Gustavus Hinrichs, *A Programme of Atomechanics; Or, Chemistry as a Mechanics of the Panatoms* (Iowa City, 1867), <https://books.google.com/books?id=3jtSAAAACAAJ>.

<sup>149</sup> See for example, Gustavus Hinrichs, "On the Classification and the Atomic Weights of the So-called Chemical Elements, With Reference to Stas' Determinations," *Proceedings of the American Association for the Advancement of Science* 18 (1869): 112-124, <https://hdl.handle.net/2027/uc1.b3082769?urlappend=%3Bseq=158>.

<sup>150</sup> Gustavus Hinrichs, "Natural Classification of the Elements," *The Pharmacist* 1 (1869): 12, <https://hdl.handle.net/2027/chi.095492771?urlappend=%3Bseq=50>.

Unlike Chancourtois's *vis tellurique*, Hinrichs's *Atomechanik* received a fair amount of attention, in part because Hinrichs was a self-promoter.<sup>151</sup> He mailed dozens of copies of his *Atomechanics* to individuals as well as to societies and libraries.<sup>152</sup> Such efforts were not a guarantee that the work would be read, but it must have piqued the interest of some chemists as it was reviewed in a variety of scientific journals, including the *Chemical News*,<sup>153</sup> the *Neues Jahrbuch für Mineralogie, Geologie und Paläontologie*<sup>154</sup> (translated into English in the *American Journal of Science*),<sup>155</sup> and the *Mechanics' Magazine*<sup>156</sup> (who printed the review from

---

<sup>151</sup> A prime example of this is his publication of letters of support he received from French scientists, not only for his scientific work but for the work he did to erect a statue of Lavoisier in Paris; G.-D. Hinrichs, *1873-1910. Quelques lettres, en facsimilé, de quelques collègues, membres de l'Institut de France, Académie des sciences, sur le calcul des poids atomiques, sur l'unité de la matière et sur le monument Lavoisier* (St. Louis: Woodward & Tiernan Printing Co., 1910), <http://hdl.handle.net/2027/wu.89102114857>.

<sup>152</sup> The initial list of those who received a copy was appended to the printed, English-language version of the *Atomechanik*; Hinrichs, *Programme of Atomechanics*, [4].

<sup>153</sup> "A Programme of Atomechanics," Review of *Programme der atomechanik oder die chemie eine mechanik der panatome*, by Gustavus Hinrichs, *Chemical News* 16 (1867): 289-290, <https://hdl.handle.net/2027/njp.32101075379089?urlappend=%3Bseq=667>.

<sup>154</sup> H. Fleck, "G. Hinrichs: Atomechanik oder die Chemie eine Mechanick der Panatome," Review of *Programme der atomechanik oder die chemie eine mechanik der panatome*, by Gustavus Hinrichs, *Neues Jahrbuch für Mineralogie, Geologie und Paläontologie*, 1868: 333-335, <https://hdl.handle.net/2027/mdp.39015065878327?urlappend=%3Bseq=357>. The *Jahrbuch* published Hinrichs's response to Fleck's review in the same volume, pp. 882-883.

<sup>155</sup> "Hinrich's Atom Mechanics," Review of *Programme der atomechanik oder die chemie eine mechanik der panatome*, by Gustavus Hinrichs, *American Journal of Science and the Arts*, 2<sup>nd</sup> ser., 46 (1868): 258-260, <https://biodiversitylibrary.org/page/36897953>.

<sup>156</sup> "The New Science – Atomechanics," Review of *Programme der atomechanik oder die chemie eine mechanik der panatome*, by Gustavus Hinrichs, *Mechanics' Magazine*, n.s., 18 (1867): 424.

the *Mining Journal*). While the reviews were not terribly positive – Hugo Fleck referred to it as a “fantastic air-castle”<sup>157</sup> – they did ensure that his work became known to a large audience. But like the *vis tellurique*, Hinrichs’s *Atomechanics* was not adopted as a classification system for the elements, likely because of its reliance on pantogen, a theoretical entity, rather than on the results of decades of experimental research into the atomic weights of the elements.

John A. R. Newlands was also a self-promoter. He published frequently, primarily in the weekly *Chemical News*, which had a wide circulation both within and outside of Great Britain. Twenty years following their initial publication, he gathered his works on the classification of the elements together into one collection,<sup>158</sup> largely for the purpose of pressing a priority claim for the discovery of the periodic law.<sup>159</sup> Newlands’s work was occasionally the target of amusement among his contemporaries. In the paper he read about his system at a meeting of the Chemical Society of London in March 1866, he compared the frequency of repeating characteristics to the musical octave, causing one audience member “humourously” asked whether or not “he had ever examined the elements according

---

<sup>157</sup> “Hinrich’s Atom Mechanics,” 260. Fleck, “G. Hinrichs,” 335; “phantastische Luftschloss.”

<sup>158</sup> John A. R. Newlands, *On the Discovery of the Periodic Law, and On Relations Among the Atomic Weights*, (London: E. & F. N. Spon, 1884), <https://books.google.com/books?id=OysKESmPLNEC>.

<sup>159</sup> After 1885, Newlands was widely considered in Great Britain to have been a co-discoverer of the periodic law, and in 1887 was awarded the Davy Medal by the Royal Society “for his discovery of the Periodic Law of the Chemical Elements,” five years after it was awarded jointly to Lothar Meyer and Mendeleev “for their Discovery of the Periodic Relations of the Atomic Weights”; G. G. Stokes, “Anniversary Meeting,” *Proceedings of the Royal Society of London* 43 (1887-1888): 195, <http://www.jstor.org/stable/114532>.

to the order of their initial letters?"<sup>160</sup> Despite such remarks, Newlands's work was not summarily dismissed by chemists.

After arranging the elements in order of their atomic weights, Newlands observed that "the numbers of analogous elements generally differ either by 7 or by some multiple of seven." He referred to this "peculiar relationship" as the Law of Octaves as the same characteristics reappeared every eight elements.<sup>161</sup> He presented this system as a simple table in which the elements were arranged in eight columns and seven rows (Fig. 6).<sup>162</sup> The elements proceeded in columns according to their weights, so that the first seven were in the first column, the second seven in the second column, and so on. There were several pairs of elements with essentially the same weight, which were placed together in a column, so that, for example, the third column had eight elements but still seven lines as cobalt and nickel occupied the same line. He also assigned each element an ordinal number (i.e., 1, 2, 3) based on its atomic weight order, and in the table, the elements are designated both by their symbol and their number (e.g., hydrogen is H 1, lithium is Li 2).<sup>163</sup>

---

<sup>160</sup> "Chemical Society," *Chemical News* 13 (1866): 113, <https://hdl.handle.net/2027/njp.32101075379071?urlappend=%3Bseq=113>.

<sup>161</sup> John A. R. Newlands, "On the Law of Octaves," *Chemical News* 12 (1865): 83, <https://hdl.handle.net/2027/njp.32101075379063?urlappend=%3Bseq=407>.

<sup>162</sup> Newlands, "On the Law of Octaves," *Chemical News* 12 (1865): 83.

<sup>163</sup> It is sometimes claimed that, because of his use of ordinal numbers, Newlands prematurely discovered atomic numbers, however, such a concept was far from being discovered in the 1860s; see Wendell H Taylor, "J. A. R. Newlands: A Pioneer in Atomic Numbers," *Journal of Chemical Education* 26 (1949): 491-496, doi:10.1021/ed026p491. More recently, Gordon Woods wrote, "He had thus *unknowingly* used atomic numbers, not then a current term!"; Gordon Woods, "British Reception of Periodicity," in *Early Responses to the Periodic System*, edited

No.	No.	No.	No.	No.	No.	No.	No.	No.	No.
H 1	F 8	Cl 15	Co & Ni 22	Br 29	Pd 36	I 42	Pt & Ir 50		
Li 2	Na 9	K 16	Cu 23	Rb 30	Ag 37	Cs 44	Tl 53		
G 3	Mg 10	Ca 17	Zn 25	Sr 31	Bd 38	Ba & V 45	Pb 54		
Bo 4	Al 11	Cr 19	Y 24	Ce & La 33	U 40	Ta 46	Th 56		
C 5	Si 12	Ti 18	In 26	Zr 32	Sn 39	W 47	Hg 52		
N 6	P 13	Mn 20	As 27	Di & Mo 34	Sb 41	Nb 48	Bi 55		
O 7	S 14	Fe 21	Se 28	Ro & Ru 35	Te 43	Au 49	Os 51		

(NOTE.—Where two elements happen to have the same equivalent, both are designated by the same number.)

Figure 2.6: Newlands's Table (1865)

Gladstone, himself interested in the classification of the elements, raised the objection that Newlands's system did not allow for the discovery of new elements. This was a reasonable objection as four new elements had been discovered in recent years and "the finding of one more would throw out the whole system."<sup>164</sup> Newlands stated that he was "far from thinking that the discovery of new elements (or the revision of the atomic weights of those already known) will upset, for any length of time, the existence of a simple relation among the elements, when arranged in the order of their atomic weights." He noted that a relationship that currently existed was unlikely to change due to the discovery of new elements. Although he suggested there was a difference of seven in the numbers of analogous elements, there was no reason that number could not increase.<sup>165</sup>

Newlands used tables in his papers in a similar way to Odling. One such table, used to illustrate his process, was preceded by the text, "While upon the

by Masanori Kaji, Helge Kragh, and Gábor Palló (New York: Oxford University Press, 2015), 78.

<sup>164</sup> "Chemical Society," 113.

<sup>165</sup> John A. R. Newlands, "On the 'Law of Octaves'," *Chemical News* 13 (1866): 130, <https://hdl.handle.net/2027/njp.32101075379071?urlappend=%3Bseq=130>.

subject of ‘relations among the equivalents,’ I may observe that the most important of these may be seen at a glance in the following table....”<sup>166</sup> In the short length allotted to papers in journals like the *Chemical News*, such explanatory tables allowed Newlands and other authors to present their ideas in greater detail than would have been possible with the number of words that would fit in a similar space. Tabular forms of classification systems were also more likely to be printed, as they generally did not require extra work as did plates, fold-out or not, that had to be specially printed and inserted into a publication. While spirals and helices were perhaps more visually appealing, tables were more practical.

Tabular forms were practical in other ways. According to the historian Matthew Daniel Eddy, “The main forms of visual representation on paper in Scottish schools were pictures composed from either words or lines.” (This was most likely true of European and American schools, as well.) Tables and diagrams of various kinds were used in a wide array of subjects from grammar and spelling to algebra and catechism.<sup>167</sup> As a consequence, when a student entered university, “a core mnemonic skill he had in his possession was the ability to memorize information that had been plotted along various lines arranged geometrically on the page.”<sup>168</sup> Chemical educators across Europe had been using tables in their courses since at least the mid-eighteenth century. Affinity tables, relying on gridded structures and

---

<sup>166</sup> John A. R. Newlands, “Relations Between Equivalents,” *Chemical News* 10 (1864): 59, <https://hdl.handle.net/2027/njp.32101075379055?urlappend=%3Bseq=347>.

<sup>167</sup> Matthew Daniel Eddy, “The Shape of Knowledge: Children and the Visual Culture of Literacy and Numeracy,” *Science in Context* 26 (2013): 215-245, doi:10.1017/S0269889713000045.

<sup>168</sup> Matthew Daniel Eddy, “How to See a Diagram: A Visual Anthropology of Chemical Affinity,” *Osiris* 29 (2014): 182, doi:10.1086/678093.

spatial relationships, were “a pictorial mode of representation [that] was more practical, and more accessible, than a verbal list of principles or rules of elective attraction.”<sup>169</sup> It likely felt natural to most chemists to visualize a classification of the elements in a tabular form.

### **Chemical Education and the Organization of the Elements**

For many of those who attempted to organize the elements in a meaningful way, whether through the seeking of triads and conjugated triads, or the development of a larger classification system, research and education were intertwined to some degree. Chancourtois was working on a monograph on lithography when this research led him to a classification of the elements. Of this classification, he noted:

looking upon it only as a concise representation of known facts, and reducing it to the points which offer no matter for discussion, the geometrical table of numerical characteristics affords a rapid method for teaching a large number of notions in physics, chemistry, mineralogy, and geology.<sup>170</sup>

Although Chancourtois did not explicitly design his *vis tellurique* for educational purposes, he certainly saw its usefulness in that context. While it was not the case with him, others came to classifications because of their teaching.

Cooke, in his paper on the numerical relations between the elements, stated, “Every teacher of Chemistry must have felt the want of some system of classification like those which so greatly facilitate the acquisition of the natural-history sciences.” He found the usual classification of the elements into metals and metalloids to be

---

<sup>169</sup> Eddy, “How to See,” 190.

<sup>170</sup> Hartog, “A First Foreshadowing,” 187. Béguyer de Chancourtois, “Mémoire sur un classement,” 760-761; “Enfin, à ne l’envisager....”

unsatisfactory for teaching. In response to the difficulty he noticed his students had with this system, Cooke created his own, developed specifically for use in his lectures:

As the classification has been in use for some time in the courses of lectures on Chemistry given at Harvard University, I have had an opportunity for observing its value in teaching, and cannot but feel that the object for which it was made has been in a great measure attained.<sup>171</sup>

Cooke clearly felt it was a valuable teaching tool but it isn't clear if he used this classification system in his research, as well.

In this regard, Cooke made an interesting comment in his paper: "It [the classification] was originally made, as has already been said, simply for the purpose of teaching, and never would have been published had it not led to the discovery of the numerical relation between the atomic weights."<sup>172</sup> Indeed, Cooke did little more than mention it was useful in the classroom. He did not state how the classification was disseminated to students: Was it drawn on a chalkboard, printed and hung in the lecture room, printed and sold to students along with their textbook? Cooke does not appear to have used it in his own textbooks. None of the editions of the two textbooks he published before 1869, *Elements of Chemical Physics* and *First Principles of Chemical Philosophy*, contain his classification system. Nor does it appear in any edition of *Chemical Problems and Reactions*, a book he prepared for Harvard College undergraduates to use with Stöckhardt's *Elements of Chemistry*.<sup>173</sup>

---

<sup>171</sup> Cooke, "The Numerical Relation," 236.

<sup>172</sup> Cooke, "The Numerical Relation," 239.

<sup>173</sup> Cooke used the title *Elements of Chemistry* but the English translation of Julius Adolph Stöckhardt's *Die Schule der Chemie* was titled *Principles of Chemistry*. It is



Cooke seems to have held a more traditional view of the relationship between research and pedagogy, conforming to an official syllabus or set of exams and keeping ideas that were not (yet) widely accepted out of textbooks.<sup>174</sup> Such a view not held by all chemists, but Cooke was far from the only one to hold it. One of the most popular and long-published chemistry textbooks in English was William Allen Miller's *Elements of Chemistry: Theoretical and Practical*. From the first edition in 1856<sup>175</sup> until well into the 1870s,<sup>176</sup> Miller continued to use the traditional classification of metals and metalloids. The same is true of Victor Regnault's *Cours*

---

interesting that the English translation was made by Charles Henry Peirce, a professor of chemistry at Harvard's Lawrence Scientific School, at the behest of Eben Norton Horsford, who was also a professor of chemistry at Harvard. Pedagogical tools at Harvard seem to have been locally, but not widely, shared. See Julius Adolph Stöckhardt, *The Principles of Chemistry*, trans. by C. H. Peirce (Cambridge: John Bartlett, 1850), iii, <https://books.google.com/books?vid=HARVARD:32044091852301>.

<sup>174</sup> This was one tradition of chemical textbook writing in the mid-nineteenth century that has been identified; see Mercè Izquierdo, "Three Rhetorical Constructions of the Chemistry of Water," in Anders Lundgren and Bernadette Bensaude-Vincent, eds., *Communicating Chemistry: Textbooks and Their Audiences, 1789-1939* (Canton, MA: Science History Publications/USA, 2000), 256-257.

<sup>175</sup> William Allen Miller, *Elements of Chemistry: Theoretical and Practical*, Pt. 2, (London: John W. Parker and Son, 1856), 435-438, <https://archive.org/details/elemchemistry02millrich>.

<sup>176</sup> The first mention of an alternative classification is made in the 6<sup>th</sup> edition (1878) when the periodic law is discussed in a section near the end of the second volume, while the traditional classification is still used in the main text; William Allen Miller, *Elements of Chemistry: Theoretical and Practical*, 6<sup>th</sup> ed., pt. 2, rev. by Charles E. Groves (London: Longmans, Green, Reader, and Dyer, 1878), 12-15, 974-977, <https://archive.org/details/elemofchemis02millrich>.

*Élémentaire de Chimie*,<sup>177</sup> the editions of which were translated regularly into English<sup>178</sup> and German<sup>179</sup> and were widely used for several decades.

However, by 1860, it was no longer an uncommon practice for a textbook author to incorporate his own research findings into the text. Nor was it seen as an uncouth one as it had been earlier in the nineteenth century when, for example, Humphrey Davy's *Elements of Chemical Philosophy* was vilified for straying from "the prevailing ethic of textbook authorship ... in which generosity of credit, comprehensiveness, and balance were the prized qualities."<sup>180</sup> In a study of French chemistry textbooks, historian Bernadette Bensaude-Vincent found that professors "positioned themselves as actors at the forefront of the science and often mentioned their own results along with those of other well-known predecessors or colleagues."<sup>181</sup> This was in part because textbooks were no longer being written only by well-known chemists. Rather, writing a textbook was one way to become an established figure. Mendeleev stated that writing his organic chemistry textbook

---

<sup>177</sup> V. Regnault, *Cours Élémentaire de Chimie*, Vol. 1, 5<sup>th</sup> ed. (Paris: L. Langlois; Victor Masson, 1859), §55, <https://books.google.com/books?id=hIUMAQAIAAJ>.

<sup>178</sup> V. Regnault, *Elements of Chemistry*, trans. by T. Forrest Betton, vol. 1 (Philadelphia: Henry Carey Baird, 1865), §55, <https://books.google.com/books?id=WQxDAAAIAAJ>.

<sup>179</sup> Victor Regnault, and Adolph Strecker, *Regnault-Strecker's Kurze Lehrbuch der chemie*, vol. 1 (Braunschweig: Friedrich Viewig und Sohn, 1864), §55, <https://books.google.com/books?id=4K05AAAACAAJ>.

<sup>180</sup> Jan Golinski, *Science as Public Culture: Chemistry and Enlightenment in Britain, 1760-1820* (New York: Cambridge University Press, 1992), 258. For the discussion of Davy's textbook writing failure see pp. 255-258.

<sup>181</sup> Bernadette Bensaude-Vincent, "From Teaching to Writing: Lecture Notes and Textbooks at the French *École polytechnique*," in Anders Lundgren and Bernadette Bensaude-Vincent, eds., *Communicating Chemistry: Textbooks and Their Audiences, 1789-1939* (Canton, MA: Science History Publications/USA, 2000), 291.

“established my name in Russia because it was sold rapidly and everywhere.”<sup>182</sup> In his tribute to Lothar Meyer, chemist M. M. Pattison Muir stated that Meyer’s textbook *Modernen Theorien* was “the work on which his reputation as a philosophical chemist chiefly rests.”<sup>183</sup>

Textbooks were not, as Kuhn stated, simply a statement of “normal” science, instilling in students the current laws, theories, and experimental techniques of the field.<sup>184</sup> Rather in the mid-nineteenth century, textbooks were assisting in “[t]he task of stabilizing a body of knowledge.”<sup>185</sup> Along with scientific journals, they were a venue for espousing new and/or controversial theories and for presenting new experimental results.<sup>186</sup> The whiff of controversy as well as the up-to-date quality of research and, increasingly, of theory was also “one strategy for making chemistry

---

<sup>182</sup> Nathan M. Brooks, “Dmitrii Mendeleev’s *Principles of Chemistry* and the Periodic Law of the Elements,” in Anders Lundgren and Bernadette Bensaude-Vincent, eds., *Communicating Chemistry: Textbooks and Their Audiences, 1789-1939* (Canton, MA: Science History Publications/USA, 2000), 299.

<sup>183</sup> M. M. Pattison Muir, “Professor Lothar Meyer,” *Scientific American Supplement* 40 (1895): 16271, <https://hdl.handle.net/2027/uc1.31210014472623?urlappend=%3Bseq=13>.

<sup>184</sup> See Thomas S. Kuhn, “The Function of Measurement in Modern Physical Science,” in *The Essential Tension: Selected Studies in Scientific Tradition and Change* (Chicago: The University of Chicago Press, 1977): 178-224; “The Essential Tension: Tradition and Innovation in Scientific Research,” in *Essential Tension: 225-239*; *The Structure of Scientific Revolutions*, 3<sup>rd</sup> ed. (Chicago: The University of Chicago Press, 1996).

<sup>185</sup> John Hedley Brooke, “Introduction: The Study of Chemical Textbooks,” in Anders Lundgren and Bernadette Bensaude-Vincent, eds., *Communicating Chemistry: Textbooks and Their Audiences, 1789-1939* (Canton, MA: Science History Publications/USA, 2000), 7.

<sup>186</sup> As Michael Gordin noted in regard to Mendeleev and Meyer, the way in which authors spoke about controversies and new theories in textbooks was often different than their discussions in other scientific literature. See Michael Gordin, “The Textbook Case of a Priority Dispute: D. I. Mendeleev, Lothar Meyer, and the Periodic System,” in *Nature Engaged: Science in Practice from the Renaissance to the Present*, edited by Mario Biagioli and Jessica Riskin (New York: Palgrave Macmillan, 2012), 59-82.

appear exciting, as a subject that was forever breaking new bounds.”<sup>187</sup> Textbooks were not always stodgy, boring books.

In France, an on-going debate between types of classification systems was of prime pedagogical concern. Some chemical educators viewed “natural” classifications, which were based on all of the characteristics of substances, to be best as they conveyed “general ideas” the students could continue to apply as they advanced in their study of chemistry. Others believed “artificial” classifications, based on a single characteristic, were easier for students to learn and to memorize.<sup>188</sup> Textbook authors used their texts as platforms, arguing that their classification of choice facilitated learning while others were incomplete or presented false views of chemical facts.<sup>189</sup> These texts often reflected “the individual experience of a teacher-writer” and “expressed original and ambitious interpretations,” rather than following an officially prescribed syllabus.<sup>190</sup>

An example of a chemist whose texts were expressions of his own beliefs was Odling. He used his textbooks to promulgate the classification system he had devised, as well as theories that were not yet widely accepted. In the second and third editions of *A Course of Practical Chemistry Arranged for the Use of Medical Students*, Odling presented his classification system in the form of a table in the

---

<sup>187</sup> Brooke, “Introduction,” 8.

<sup>188</sup> José Ramón Bertomeu-Sánchez, Antonio García-Belmar, and Bernadette Bensaude-Vincent, “Looking for an Order of Things: Textbooks and Chemical Classifications in Nineteenth Century France,” *Ambix* 49 (2002): 243.

<sup>189</sup> Bertomeu-Sánchez, García-Belmar, Bensaude-Vincent, “Looking for an Order of Things,” 242.

<sup>190</sup> Bertomeu-Sánchez, García-Belmar, Bensaude-Vincent, “Looking for an Order of Things,” 250.

Appendix.<sup>191</sup> This table clearly comes from the research he presented in his paper on the proportional numbers of the elements, while the tables he published in an 1864 pamphlet are evidence of his progress towards that system.<sup>192</sup> One reviewer of this pamphlet noted, “He adopts an original mode of classifying the elements which is, perhaps, as reasonable as any other yet proposed, or possible, in the present state of our knowledge of these bodies.”<sup>193</sup> While that reviewer thought the tables would be of “great assistance to students,” another complained that the “constant changes” were regrettable as “they discourage chemical students from pursuing the unitary system, while they lead those who are averse to the general introduction of chemistry into colleges and schools to regard its study of little value in mental culture.”<sup>194</sup>

This critique is interesting as Odling was an early proponent of the unitary system, developed by Charles Gerhardt and Auguste Laurent. As the English

---

<sup>191</sup> William Odling, *A Course of Practical Chemistry Arranged for the Use of Medical Students*, 2<sup>nd</sup> ed. (London: Longmans, Green, and Co., 1865), 226, <https://books.google.com/books?id=f49JAAAAYAAJ>. I have been unable to locate a copy of the 3<sup>rd</sup> edition in English but I assume the table is there as it is in the French translation of that edition; William Odling, *Cours de Chimie Pratique (Analytique, Toxicologique, Animale) a l'Usage des Étudiants en Médecine*, trans. from the 3<sup>rd</sup> ed. by A. Naquet (Paris: F. Savy, 1869), 261, <https://hdl.handle.net/2027/ucm.5321310309>.

<sup>192</sup> William Odling, *Tables of Chemical Formulæ* (London: Taylor and Francis, 1864), Table I-III, <https://archive.org/details/b22299452>.

<sup>193</sup> “Chemical Formulæ,” review of *Tables of Chemical Formulæ* by William Odling. *Quarterly Journal of Science* 1 (1864): 380, <https://hdl.handle.net/2027/mdp.39015013721371?urlappend=%3Bseq=414>.

<sup>194</sup> “Tables of Chemical Formulæ,” review of *Tables of Chemical Formulæ* by William Odling, *British And Foreign Medico-Chirurgical Review* 35 (1865): 147, <https://hdl.handle.net/2027/mdp.39015024483805?urlappend=%3Bseq=759>.

translator of Laurent's *Chemical Method*,<sup>195</sup> he was able to present the new theories “in a clear and understandable manner,” as well as making use of the translator’s preface to explain why they were important.<sup>196</sup> He also used his own textbooks to spread this “new chemistry.” In an introduction to his *A Manual of Chemistry*, Odling stated, “The views, of which it is an exponent, are based on those originally promulgated by Laurent and Gerhardt in France.” Benjamin Brodie encouraged Odling in the writing of the text, as he “wished to have, for the use of his class at Oxford, a chemical text-book arranged in accordance with his own method of teaching.” Brodie was one of the English chemists that Odling listed as having adopted and contributed to the development of Laurent’s and Gerhardt’s work.<sup>197</sup>

Hinrichs was another chemist whose beliefs about teaching and theory were displayed in his textbooks. He was considered to be “excellent at teaching science,” in the lecture hall and the laboratory and by way of textbooks.<sup>198</sup> The texts he wrote were intended to be different than other textbooks. In the preface of his

*Introduction to General Chemistry*, he stated:

For a century, our chemical text-books have been modelled on one pattern. They all begin with general principles that require advanced knowledge to be understood. The student is first directed to observe that which he cannot see, and to comprehend that which it took old chemists centuries to learn. At

---

<sup>195</sup> August Laurent, *Chemical Method, Notation, Classification, & Nomenclature*, trans. by William Odling (London: Harrison and Sons, 1855), <https://books.google.com/books?id=xyJT5z0t8j8C>.

<sup>196</sup> Susie Fisher, “William Odling: ‘Interpreter and Liaison-Officer,’ Advocate of a New System of Chemistry,” *Ambix* 43 (1996): 149.

<sup>197</sup> William Odling, *A Manual of Chemistry: Descriptive and Theoretical* (London: Longman, Green, Longman, and Roberts, 1861), v, [https://hdl.handle.net/2027/uc1.\\$b35374](https://hdl.handle.net/2027/uc1.$b35374).

<sup>198</sup> Palmer, W. P., “Dissent at the University of Iowa: Gustavus Detlev Hinrichs – Chemist and Polymath,” *Khymia / Chemistry: Bulgarian Journal of Science Education* 16 (2007): 543.

the same time, that which is common and of great practical importance, is withheld till late in the course or entirely omitted.<sup>199</sup>

In contrast, his textbooks were meant to be interactive and to engage students in the process of learning. *The Elements of Chemistry and Mineralogy* contained a Journal of Experiments after the text proper. This consisted of blank pages in which students were to record the experiments, listed throughout the text, they had performed. The Journal also included “blanks” of the tabular form of Hinrichs's system of the elements. Students were to draw various boundary lines to illustrate the divisions between metals, metalloids, gaseous elements, etc., as had been described in the text.

Hinrichs was very much in line with the antebellum American tradition of the use of educational apparatus, such as blackboards, and the use of visible illustrations, such as charts and pictures.<sup>200</sup> *Introduction to General Chemistry* began and ended with what he called The Student's Atlas, comprising portraits of famous scientists and important institutions, as well as photos, illustrations, charts, graphs, and diagrams of various things ranging from gems and minerals to spectra and laboratory apparatus. In *The Elements of Chemistry and Mineralogy*, Hinrichs instructed teachers to draw the “blank” form of his classification system “[o]n a wooden tablet, one meter square” so that boundary lines, and other relationships,

---

<sup>199</sup> Gustavus Detlef Hinrichs, *Introduction to General Chemistry: A Graded Course of One Hundred Lectures* (St. Louis: Carl Gustav Hinrichs, Publisher, 1897), 11, <https://books.google.com/books?id=zhVDAAAIAAJ>.

<sup>200</sup> Deborah Jean Warner, “Commodities for the Classroom: Apparatus for Science and Education in Antebellum America,” *Annals of Science* 45 (1988): 391.

could be drawn with chalk during lecture.<sup>201</sup> The spiral representation of his system of the elements, originally published in his *Atomechanik* of 1867, was produced as a wall chart that hung “near or over the experiment table in [his] lecture hall.”<sup>202</sup>

Photos of this wall chart also appeared in several of his textbooks.<sup>203</sup>

Hinrichs did not shy away from contemporary debates. His textbooks were highly polemical, particularly when it came to the classification of the elements. Hinrichs held distinct views on the periodic law and on atomic weights that differed greatly from the widely accepted ones. In Lecture 100 of his *Introduction to General Chemistry*, Hinrichs stated his position on the periodic law and the discovery of a system for classifying the elements:

There is of course no such a thing as a real PERIODIC SYSTEM of the elements – consecutive spires of eight elements each, increasing the atomic weight by sixteen for each spire. This is nothing but a hasty generalization from my *Atomechanik* of 1867 on the part of Lothar Meyer. He reviewed my book, condemned it; then published his periodic law. See how Mendelejeff’s is only a reflection of mine....<sup>204</sup>

While asserting his own claims for priority – and despite his own views – Hinrichs gave students a basic understanding of the periodic system as formulated by Meyer and Mendeleev. By providing illustrations of his own system in his textbooks, having a copy of it hanging on the wall in his lecture hall, and providing students

---

<sup>201</sup> Gustavus Detlef Hinrichs, *The Elements of Chemistry and Mineralogy: Demonstrated by the Student's Own Experiments* (Davenport, IA: Griggs, Watson, & Day, 1871), 62. The “blanks” are on pp. 169-170.

<sup>202</sup> Hinrichs, *True Atomic Weights*, 242.

<sup>203</sup> Hinrichs, *Introduction*, 391; Hinrichs, *True Atomic Weights*, plate VII between 240 and 241.

<sup>204</sup> Hinrichs, *Introduction*, 381; all caps in original.



with “blanks” which they could fill out as they progressed through the course, Hinrichs promulgated his own classification system.

By the mid-nineteenth century, textbooks had joined other forms of scientific literature as a venue for introducing and promulgating new chemical theories and experimental results, further making the relationship between teaching and research a complex one. Those with a more traditional view, such as Cooke, may have made innovations for local pedagogical purposes but did not find the incorporation of new theories into textbooks palatable. Others, such as Hinrichs and Odling, took a different view. For them, textbooks served multiple purposes beyond engaging students in the process of learning chemistry. Texts assisted in the development and refinement of new theories of their authors and/or of others, such as classification systems for the elements. They could be used to establish and defend priority claims. And they made their authors well-known – not only as educators but as researchers.

\*\*\*\*\*

Chemical education was never far from the minds of chemists, even at gatherings held to discuss contentious matters such as the difference between molecules and atoms, and the best way to determine atomic weights. On the final day of the Karlsruhe Congress, chemistry’s first international conference, Dumas presided over the discussions. The account in the *Chemical News* noted: “One important point to which he called the attention of the congress was the necessity of looking at the requirements of instruction. In this respect unity in language and in theory seemed to be most desirable.” Although chemists should, of course, retain

“an entire freedom in the drawing up of scientific memoirs,” Dumas suggested they should also “try to smooth as much as possible the difficulties produced by the divergence in these theoretical ideas.”<sup>205</sup>

Rather than smoothing difficulties, Stanislao Cannizzaro preferred to persuade fellow chemists to his point of view. By all accounts, Cannizzaro’s speeches during the Congress were at the very least impassioned. Mendeleev described him as speaking “heatedly,”<sup>206</sup> while the *Chemical News* account noted one of his speeches as being “at once remarkable both for profundity and style” as he “combated the ideas of M. Kékulé [*sic*].”<sup>207</sup> One of Cannizzaro’s Italian colleagues, Angelo Pavesi, distributed copies of a paper that had been printed in the Italian chemical journal *Il Nuovo cimento* in 1858. This paper took the form of a letter written by Cannizzaro to a colleague, outlining a chemistry course he taught at the University of Genoa. It is unknown how many attendees actually read the paper, but Lothar Meyer certainly did. He later remarked, “It was as though the scales fell from my eyes, doubt vanished, and was replaced by a feeling of peaceful certainty.”<sup>208</sup>

Lothar Meyer and Cannizzaro were just two of many chemists who were both chemical researcher and educator. As shown in this chapter, the relationship between research and pedagogy was a complex one. Chemists attempted to ease

---

<sup>205</sup> “The Congress of Chemists at Karlsruhe,” *Chemical News* 2 (1860): 226, <https://hdl.handle.net/2027/wu.89054785472?urlappend=%3Bseq=234>.

<sup>206</sup> Clara deMilt, “The Congress at Karlsruhe,” *Journal of Chemical Education* 27 (1951): 422, doi:10.1021/ed028p421.

<sup>207</sup> “The Congress of Chemists,” 226.

<sup>208</sup> deMilt, “The Congress,” 424. Stanislao Cannizzaro, “Abriss eines Lehrganges der Theoretischen Chemie vorgetragen an der K. Universität Genua,” *Ostwalds Klassiker der exakten Wissenschaften* Band 30 (Leipzig: Wilhelm Engelmann, 1891), 59, <https://hdl.handle.net/2027/nyp.33433069064255>, “Es fiel mir wie Schuppen....”

the difficulties their students encountered in learning about the elements by developing new classification systems for the elements for the classroom. Those classification systems could also be of use in the laboratory. However, many chemists were not willing to combine those uses in publications, either in journals or in textbooks, preferring to keep research and pedagogical development in separate spheres. But to a greater extent, textbooks were being used to promote new theories and to stabilize knowledge, rather than to repeat commonly accepted ideas. The use of tables in publications was also increasing, mirroring the long use of tables in chemical pedagogy. By the end of the 1860s, the intersection of research and pedagogy was growing to the extent that pedagogy influenced research.

**CHAPTER 3**  
**THE SO-CALLED ELEMENTS:**  
**THE PERIODIC LAW, THE ELEMENTS, AND THE UNITY OF MATTER, 1869-1900**

**Introduction**

In 1874, at a meeting celebrating “The Centennial of Chemistry,” the chemist and geologist T. Sterry Hunt remarked: “All things, says the sage, are ordered by weight, by measure, and by number, yet with the balance in hand Lavoisier does not seem to have comprehended this grand truth....”<sup>209</sup> Lavoisier could surely be forgiven for not understanding this “grand truth” as, by the time of Hunt’s speech, chemists were just beginning to accept the periodic law, grounded on the atomic weights of the elements. As the periodic law was tested and developed, chemists continued a slow move away from the explicitly practical nature of their science and towards a more hybrid acceptance of both theory and experiment.

Much of the research on the elements that occurred during the first half of the century – Hunt specifically mentioned Prout’s hypothesis, Döbereiner’s triads, the work of Pettenkofer and Dumas, and the work of Josiah P. Cooke, Jr., on chemical relations and equivalent weights – were “[t]he results of many years of patient labor,”<sup>210</sup> and reflected the valuation of experiment over theory. During the second half of the century, however, research on the elements would have a more

---

<sup>209</sup> T. Sterry Hunt, “A Century’s Progress in Chemical Theory,” *American Chemist* 5 (1874-75): 57,  
[https://hdl.handle.net/2027/uc1.\\$b614509?urlappend=%3Bseq=64](https://hdl.handle.net/2027/uc1.$b614509?urlappend=%3Bseq=64).

<sup>210</sup> Hunt, “A Century’s Progress,” 57.

philosophical bent for, as Hunt noted, “from the experiments of the laboratory we can only conjecture the complex nature of the so-called elementary substances.”<sup>211</sup> These conjectures included theories regarding the constitution and evolution of the elements, suggesting there might be a “more elemental form of matter,” perhaps akin to Hinrichs’s “conception of a first matter or *Urstoff*.”<sup>212</sup> The possibility of the unity of matter was once again a topic of serious conversation amongst chemists but the same apparently could not yet be said of the periodic law, only recently discovered in 1869.

There is little evidence that chemists were discussing the periodic law in the first years of the 1870s. Stephen Brush examined a number of journals and other publications published in the United States, England, France, and other countries between the years 1871 and 1890. He found that before 1876, there were very few mentions of the periodic law.<sup>213</sup> This agrees with my own survey of several English language periodicals that found little if any mention of the chemists most frequently regarded as the discoverers of the periodic law – Dmitrii Mendeleev, Lothar Meyer, and John A. R. Newlands<sup>214</sup> – or of the periodic law itself. Chemists may have discussed the periodic system in person and in correspondence rather than in journals, but the evidence is too thin to permit conclusions.

---

<sup>211</sup> Hunt, “A Century’s Progress,” 58.

<sup>212</sup> Hunt, “A Century’s Progress,” 57-58.

<sup>213</sup> Stephen G. Brush, “The Reception of Mendeleev’s Periodic Law in America and Britain,” *Isis* 87 (1996): 601, <http://www.jstor.org/stable/235195>. Brush also surveyed textbooks; see p. 602.

<sup>214</sup> Newlands is regularly and consistently listed in British publications as a co-founder of the periodic law well into the twentieth century, whereas he is rarely mentioned in American and European publications.

Chemists had plenty to discuss when it came to the elements, as Hunt's survey showed. Along with various classification schemes, including Mendeleev's periodic law and Newlands's law of octaves, there seemed to be an increasing number of new elements being discovered. And just what was an element anyway? The commonly accepted definition was far from clear. It is no wonder that Prout's hypothesis and other ideas regarding the unity of matter were being bruited about once again. Having only one or a small group of elements as the primary matter of the universe seemed to be an answer to the problems relating to the elements. Advocates of these ideas used the periodic system as evidence for their theories.

This chapter follows the periodic law from its discovery through its development and acceptance. As the periodic system became acknowledged as a useful tool for research, visual representations of the periodic law abounded. Those espousing ideas about the evolution of the elements created visual representations of their theories that were based on the periodic system. Visual representations also proliferated for pedagogical reasons. Textbooks began to contain periodic tables and scientific supply companies began to sell wall charts. Chemical educators also began to utilize the periodic system as a means of organizing their textbooks and their courses. As the century drew to a close, the periodic system became more integrally tied to chemical education than it was to research.

### **The Discovery of the Periodic Law**

By 1869, the work on the determination of the atomic weights and the efforts to create new classification systems to organize the elements had created "generalisations and established facts" needed for the discovery of the periodic law.

The concept of periodicity – that something repeats at a regular interval – was vital to this discovery. Credit for the discovery is often granted solely to the Russian chemist Mendeleev, although into the early twentieth century credit was also often granted to the German chemist Lothar Meyer. Indeed, in 1882 the Royal Society of London jointly awarded them the Davy Medal for their discovery of the periodic relations between the atomic weights.<sup>215</sup> Regardless of who is given credit, the important role played by chemical education in the discovery cannot be ignored, as both Meyer and Mendeleev were engaged in the writing of textbooks when they recognized the importance of periodicity to the organization of the elements.

In a lecture given in 1885, Lothar Meyer recalled that he began work on a classification scheme for the elements in 1860 when he “undertook the preparation of a work which should place before chemists and other men of science the most important of the laws relating to the atoms and their compounds.”<sup>216</sup> This work would become his influential textbook *Die modernen Theorien und ihre Bedeutung für die chemische Statik (Modern Theories of Chemistry)*. Meyer found “a regular and continuous change in the valency of the elements from family to family, when the families were arranged in the order of the atomic weights of their members.”

---

<sup>215</sup> “Anniversary Meeting,” *Proceedings of the Royal Society of London* 34 (1882-1883): 329, <http://www.jstor.org/stable/113999>.

<sup>216</sup> Meyer delivered the lecture “Ueber die neuere Entwicklung der Atomlehre” at Plochingen on 25 January 1885. Translated excerpts are in P. Phillips Bedson, “Lothar Meyer Memorial Lecture,” in *Memorial Lectures Delivered Before the Chemical Society, 1893-1900* (London: Gurney and Jackson, 1901), 1414, <https://books.google.com/books?id=MYFFAQAAIAAJ>.

However, there were some groups that “could not in any way consistently be brought into arrangement with the other elementary bodies.”<sup>217</sup>

As Meyer revised his textbook, he also refined his classification. The first edition of *Modernen Theorien* contained one table with only 28 of the elements, arranged by atomic weights and organized into six families (Fig. 1).<sup>218</sup> By 1868, he had developed a table containing 52 elements, a majority of known elements, which were arranged in 15 families with one family per column (Fig. 2). This table was likely intended for inclusion in the second edition of *Modernen Theorien*, published in 1872, however it appears to have been lost and forgotten until it resurfaced in 1893. This larger table, incorporating most of the known elements, was published in 1895.<sup>219</sup>

	4 werthig	3 werthig	2 werthig	1 werthig	1 werthig	2 werthig
Differenz =	—	—	—	—	Li = 7,03	(Be = 9,3?)
	—	—	—	—	16,02	(14,7)
	C = 12,0	N = 14,04	O = 16,00	Fl = 19,0	Na = 23,05	Mg = 24,0
Differenz =	16,5	16,96	16,07	16,46	16,08	16,0
	Si = 28,5	P = 31,0	S = 32,07	Cl = 35,46	K = 39,13	Ca = 40,0
Differenz =	$\frac{89,1}{2} = 44,55$	44,0	46,7	44,51	46,3	47,6
	—	As = 75,0	Se = 78,8	Br = 79,97	Rb = 85,4	Sr = 87,6
Differenz =	$\frac{89,1}{2} = 44,55$	45,61	49,5	46,8	47,6	49,5
	Sn = 117,6	Sb = 120,6	Te = 128,3	J = 126,8	Cs = 133,0	Ba = 137,1
Differenz =	89,4 = 2.44,7	87,4 = 2.43,7	—	—	(71 = 2.35,5)	—
	Pb = 207,0	Bi = 208,0	—	—	(Tl = 204?)	—

Figure 3.1: Meyer’s 1864 Table

<sup>217</sup> Bedson, “Lothar Meyer,” 1414.

<sup>218</sup> Lothar Meyer, *Die modernen Theorien der Chemie und ihre Bedeutung für die chemische Statik* (Breslau: Maruschke & Berendt, 1864): 137, <https://books.google.com/books?id=pLg5AAAAcAAJ>.

<sup>219</sup> Karl Seubert, “Zur Geschichte des periodischen Systems,” *Zeitschrift für anorganische Chemie* 9 (1895): 336-337, <https://hdl.handle.net/2027/uc1.b3959055?urlappend=%3Bseq=344>.



§ 91. Entwurf eines Systems der Elemente							von LOTHAR MEYER. Sommer 1868.							
1	2	3	4	5	6	7	8	9	10	11	12	13	14	15
		Al = 27.3 $\frac{28.7}{2} = 14.3$	Al = 27.3 <sup>1</sup>								Li = 7.03 16.02	Be = 9.3 14.7		
							C' = 12.00	N = 14.04	O = 16.00	Fl = 19.0	Na = 23.05	Mg = 24.0 16.0		
							16.5	16.96	16.07	16.46	16.06	16.0		
							Si = 28.5	P = 31.0	S = 32.07	Cl = 35.46	K = 39.13	Ca = 40.0	Ti = 48	Mo = 92
							$\frac{84.1}{2} = 42.05$	44.0	46.7	44.51	46.3	47.6	42	45
Cr = 52.6	Mn = 55.1	Fe = 56.0	Co = 58.7	Ni = 58.7	Cu = 63.5	Zn = 65.0	—	As = 75.0	Se = 78.8	Br = 79.97	Rb = 85.4	Sr = 87.6	Zr = 90	Vd = 187
	49.2	48.3	47.3		44.4	46.9	89.1	45.6	49.5	46.8	47.6	49.5	47.6	47
							$\frac{2}{2} = 44.55$	45.6	49.5	46.8	47.6	49.5	47.6	47
	Ru = 104.3	Rh = 104.3	Pd = 106.0		Ag = 107.94	Cd = 111.9	89.1	45.6	49.5	46.8	47.6	49.5	47.6	47
	92.8 = 2-46.4	92.8 = 2-46.4	98 = 2-46.5		88.8 = 2-44.4	88.3 = 2-44.15	89.4 = 2-44.7	87.4 = 2-43.7						
	Pt = 197.1	Jr = 197.1	Os = 199.0		Au = 196.7	Hg = 200.2	Pb = 207.0	Bi = 208.0				? TI = 204?		

Figure 3.2: Meyer's 1868 Table

While Meyer had been writing *Modernen Theorien*, Mendeleev had been working on his own textbook, *Principles of Chemistry*. He had written the first volume and by 1869 was working on the second, for which he was looking for “some system of simple substances in order to be guided in their classification ... by some exact, definite principle.”<sup>220</sup> Mendeleev drew his first table which he labeled “An Attempt at a System of Elements, Based on Their Atomic Weight and Chemical Affinity,” early in 1869 (Fig. 3).<sup>221</sup> This vertical table was included in the paper published in the *Journal of the Russian Chemical Society* in April 1869. Mendeleev was quite clear that this table was only one attempt at an arrangement of the elements:

I shall now give one of the many systems of elements which are based upon the atomic weight. It forms but one attempt to represent the results which can be achieved in this direction. I am quite conscious of the fact that this attempt is not final, but it appears to me to already express quite clearly the applicability of my proposed principle to all elements whose atomic weights have been determined with some reliability.<sup>222</sup>

<sup>220</sup> Dmitri Mendeleev, “On the Correlation Between the Properties of the Elements and Their Atomic Weights,” in Dmitri Mendeleev, *Mendeleev on the Periodic Law: Selected Writings, 1869-1905* (Mineola, NY: Dover Publications, Inc., 2002), 24.

<sup>221</sup> The Julian calendar was still in use in Russia, while most of the Western world was using the Gregorian calendar. Mendeleev gave the table a date of 17 February 1869, which equates to 1 March 1869.

<sup>222</sup> Mendeleev, “On the Correlation,” 27.

As evidence of this statement, alternative tables, horizontal rather than vertical, were included in an accompanying footnotes.<sup>223</sup>

			Ti=50	Zr=90	?=180.
			V=51	Nb=94	Ta=182.
			Cr=52	Mo=96	W=186.
			Mn=55	Rh=104, <sup>4</sup>	Pt=197, <sup>4</sup>
			Fe=56	Ru=104, <sup>4</sup>	Ir=198.
			Ni=Co=59	Pl=106 <sup>6</sup> ,	Os=199.
			Cu=63, <sup>4</sup>	Ag=108	Hg=200.
H=1			Zn=65, <sup>2</sup>	Cd=112	
Be=9, <sup>4</sup>	Mg=24		?=68	Ur=116	Au=197?
B=11	Al=27, <sup>4</sup>		?=70	Sn=118	
C=12	Si=28		As=75	Sb=122	Bi=210
N=14	P=31		Se=79, <sup>4</sup>	Te=128?	
O=16	S=32		Br=80	I=127	
F=19	Cl=35, <sup>5</sup>		Rb=85, <sup>4</sup>	Cs=133	Tl=204
Li=7	Na=23		Sr=87, <sup>6</sup>	Ba=137	Pb=207.
			?=45	Ce=92	
			?Er=56	La=94	
			?Yt=60	Di=95	
			?In=75, <sup>6</sup>	Th=118?	

**Figure 3.3: Mendeleev's 1869 Table**

An abstract of Mendeleev's paper appeared in German in the *Zeitschrift für Chemie* in 1869. Lothar Meyer quickly drew up an account of his own work. Dated December 1869, it appeared in the *Annalen der Chemie* in 1870.<sup>224</sup> He included a new table which he described as being "essentially identical with that given by Mendeleev."<sup>225</sup> This table contained 56 elements in nine columns, drawn in the vertical style of Mendeleev's original table (Fig. 4).<sup>226</sup> Gaps were left for elements

<sup>223</sup> The tables can be found in D. Mendeleev, "Sootnoshenie svoistv s atomnym vesom elemntov," *Zhurnal Russkogo Khimicheskogo Obshchestva* 1 (1869): 69-71, [https://hdl.handle.net/2027/uc1.\\$b625235?urlappend=%3Bseq=70](https://hdl.handle.net/2027/uc1.$b625235?urlappend=%3Bseq=70).

<sup>224</sup> Lothar Meyer, "Die Natur der chemischen Elemente als Function ihrer Atomgewichte," *Annalen der Chemie*, supp. 7 (1870): 354-364, <https://hdl.handle.net/2027/mdp.39015026326531?urlappend=%3Bseq=364>.

<sup>225</sup> Julius Lothar Meyer, "The Nature of the Chemical Elements as a Function of Their Atomic Weights," in *A Source Book in Chemistry, 1400-1900*, ed. Henry M. Leicester and Herbert S. Klickstein (Cambridge: Harvard University Press, 1952), 435. This is a translation of selections from Meyer's 1870 paper in the *Annalen*.

<sup>226</sup> Meyer, "Die Natur," 356.

that Meyer believed would be filled either by elements already known, once their atomic weights had been better determined, or by elements that had yet to be discovered. A second figure in the paper was an atomic volume curve, illustrating the variation of atomic volume of solid elements when plotted against atomic weight (Fig. 5). Meyer noted: “It can be clearly seen from the curve that the atomic volume of the elements, like their chemical properties, is a periodic function of their atomic weight.”<sup>227</sup>

I.	II.	III.	IV.	V.	VI.	VII.	VIII.	IX.
	B = 11,0	Al = 27,3		—		? In = 118,4		Tl = 202,7
	C = 11,97	Si = 28		—		Sn = 117,8		Pb = 206,4
	N = 14,01	P = 30,9	Ti = 48		Zr = 89,7			Bi = 207,5
	O = 15,96	S = 31,98	V = 51,2	As = 74,9		Nb = 93,7	Ta = 182,2	
			Cr = 52,4	Se = 78	Mo = 95,6		Te = 128?	W = 183,5
			—	F = 19,1	Cl = 35,38	Br = 79,75		J = 126,5
					Mn = 54,8	Ru = 102,5		Os = 198,6?
					Fe = 55,9	Rh = 104,1		Ir = 196,7
					Co = Ni = 58,6	Pd = 106,2		Pt = 196,7
Li = 7,01	Na = 22,99	K = 39,04		Rb = 85,2		Cs = 132,7		
				Cu = 63,3	Ag = 107,66		Au = 196,2	
?Be = 9,3	Mg = 23,9	Ca = 39,9		Sr = 87,0	Ba = 136,8			
				Zn = 64,9	Cd = 111,6		Hg = 199,8	

Figure 3.4: Meyer’s 1870 Table

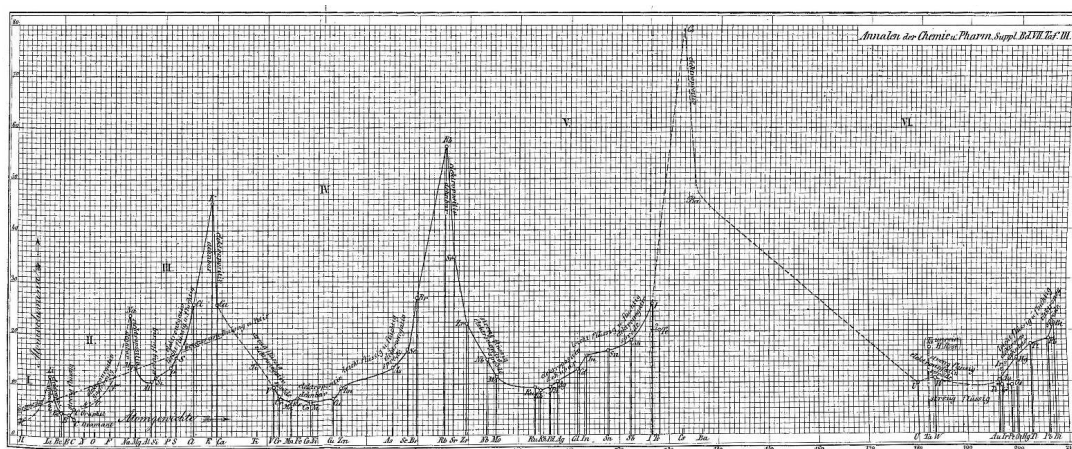

Figure 3.5: Meyer’s Atomic Volume Curve

<sup>227</sup> Meyer, “The Nature,” 438. The atomic volume curve can be found in Leicester and Klickstein, 437, and in a foldout at the end of the *Annalen* volume.

Meyer's atomic volume curve also suggested there were errors in the determination of some atomic weights. He stated: "It would be premature to make any changes in the accepted values of the atomic weights on grounds so uncertain."<sup>228</sup> Mendeleev had no such compunction and was quite willing to flip the positions of elements in his table and to change their atomic weights. Later, Meyer would state: "I lacked the boldness to formulate such far-reaching conjectures as Mr. Mendeleeff pronounced with confidence."<sup>229</sup> Despite this statement, historian Michael Gordin argued that it was a matter of pedagogy versus journal literature. He noted that Mendeleev left "extensive discussion of prediction out of his [textbook] *Principles*" but expanded upon them in papers, whereas Meyer "held his system much closer to its original pedagogical context," not publishing papers about it.<sup>230</sup>

---

<sup>228</sup> Excerpts from Meyer's 1870 paper were also translated in Ida Freund, *The Study of Chemical Composition: An Account of its Method and Historical Development* (New York: Dover Publications, Inc., 1968), 467. With the assistance of his colleague Karl Seubert, he had already begun a painstaking redetermination of the atomic weights of the elements which would not be concluded until 1883: Lothar Meyer, and Karl Seubert, *Die Atomgewichte der Elemente aus den Originalzahlen neu berechnet* (Leipzig: Breitkopf and Härtel, 1883),

<https://books.google.com/books?id=JnEMAQAIAAJ>

<sup>229</sup> Quoted in F. A. Paneth, "A Tribute to Lothar Meyer on the Centenary of his Birth," in F. A. Paneth, *Chemistry and Beyond: A Selection from the Writings of the Late Professor F. A. Paneth* (New York: Interscience Publishers, 1964), 52. Translation of "Zur hundertsten Wiederkehr von Lothar Meyers Geburtstag," *Forschung und Fortschritt* 6 (1930): 329.

<sup>230</sup> Michael Gordin, "The Textbook Case of a Priority Dispute: D. I. Mendeleev, Lothar Meyer, and the Periodic System," in *Nature Engaged: Science in Practice from the Renaissance to the Present*, ed. Mario Biagioli and Jessica Riskin (New York: Palgrave Macmillan, 2012), 76.

Meyer held closer to a traditional view of the relationship between research and pedagogy, much as had Josiah P. Cooke, Jr. He published little about the periodic system in journals outside of the papers that he submitted in response to Mendeleev's claims regarding the discovery of the periodic law. Any reflections on pedagogical work were confined to his textbooks and to talks given at meetings of scientific organizations, such as the German Chemical Society. How much this view of pedagogy and research influenced Meyer's lack of so-called boldness is speculative but it surely played some part in his unwillingness to make conjectures in the pages of his textbook.

Whatever the reason for Mendeleev's boldness, he published new tables in 1870 and 1871. The 1870 table was much more extensive than any of those published in 1869. The horizontal table showed the elements arranged in eight columns (Fig. 6).<sup>231</sup> This table appeared in an updated version in a paper the following year, along with a longer horizontal table (Fig. 7), both of which illustrated the different periods and their relationships as stated in the periodic law. As Mendeleev defined it: "The periodic law can therefore be formulated in the following manner: *The properties of simple bodies, the constitution of their compounds, as well as the properties of these last, are periodic functions of the atomic weights of the elements.*"<sup>232</sup> The elements in the shorter table were "arranged in

---

<sup>231</sup> D. Mendeleev, "Estestvennaya sistema elementov i prmenenie ee k ukazaniyu svoistv neotkrytykh elemntov," *Zhurnal Russkogo Khimicheskogo Obshchestva* 3 (1870): 31, [https://hdl.handle.net/2027/uc1.\\$b625236?urlappend=%3Bseq=39](https://hdl.handle.net/2027/uc1.$b625236?urlappend=%3Bseq=39).

<sup>232</sup> D. Mendeleef, "The Periodic Law of the Chemical Elements," *Chemical News* 40 (1879): 267, <https://hdl.handle.net/2027/wu.89100444694?urlappend=%3Bseq=241>; emphasis in original. This is the English translation of D. Mendelejeff, "Die

groups and series, that is to say, in small periods, in such a manner that the differences between the odd and even series become very apparent.”<sup>233</sup>

	Группа I.	Группа II.	Группа III.	Группа IV.	Группа V.	Группа VI.	Группа VII.	Группа VIII. Переходя из групп I.
Типические элементы.	H=1							
Первый период.	Li=7	Be=9,4	B=11	C=12	N=14	O=16	F=19	
Рядь 1-й	Na=23	Mg=24	Al=27,3	Si=28	P=31	S=32	Cl=35,5	
2-й	K=39	Ca=40	—=44	Ti=50?	V=51	Cr=52	Mn=55	Fe=56, Co=59, Ni=59, Cu=63
3-й	(Cu=63)	Zn=65	—=68	—=72	As=75	Se=78	Br=80	
4-й	Rb=85	Sr=87	(?Yt=88?)	Zr=90	Nb=94	Mo=96	—=100	Ru=104, Rb=104, Pd=104, Ag=108
5-й	(Ag=108)	Cd=112	In=113	Sn=118	Sb=122	Te=128?	J=127	
6-й	Cs=133	Ba=137	—=137	Ce=138?				
7-й								
8-й					Ta=182	W=184		Os=199?, Ir=198?, Pt=197, Au=197
9-й	(Au=197)	Hg=200	Tl=204	Pb=207	Bi=208			
10-й				Th=232		U=240		
Высшая соляная окись.	R <sup>2</sup> O	R <sup>2</sup> O <sup>2</sup> или RO	R <sup>2</sup> O <sup>3</sup>	R <sup>2</sup> O <sup>3</sup> или RO <sup>3</sup>	R <sup>2</sup> O <sup>5</sup>	R <sup>2</sup> O <sup>5</sup> или RO <sup>5</sup>	R <sup>2</sup> O <sup>7</sup>	R <sup>2</sup> O <sup>8</sup> или RO <sup>4</sup>
Высшее водородное соединение.			(RH <sup>3</sup> )	RH <sup>4</sup>	RH <sup>5</sup>	RH <sup>6</sup>	RH	

Figure 3.6: Mendeleev’s 1870 Short Form Table

Typische Elemente									
H = 1	Li = 7	Na = 23	Cu = 63	Rb = 85	Cs = 133	—	—	—	—
	Be = 9,4	Mg = 24	Zn = 65	Sr = 87	Ba = 137	—	—	—	—
	B = 11	Al = 27,3	—	?Yt = 88?	?Di = 138?	Er = 178?	—	—	—
	C = 12	Si = 28	—	Ti = 48?	Zr = 90	Ce = 140?	?La = 180?	Th = 231	—
	N = 14	P = 31	As = 75	V = 51	Nb = 94	—	Ta = 182	—	—
	O = 16	S = 32	Se = 78	Cr = 52	Mo = 96	—	W = 184	U = 240	—
	F = 19	Cl = 35,5	Br = 80	Mn = 55	—	—	—	—	—
				Fe = 56	Ru = 104	—	Os = 195?	—	—
				Co = 59	Rh = 104	—	Ir = 197	—	—
				Ni = 59	Pd = 106	—	Pt = 198?	—	—
					Ag = 108	—	Au = 199?	—	—
					Cd = 112	—	Hg = 200	—	—
					In = 113	—	Tl = 204	—	—
					Sn = 118	—	Pb = 207	—	—
					Sb = 122	—	Bi = 208	—	—
					Te = 125?	—	—	—	—
					J = 127	—	—	—	—

Figure 3.7: Mendeleev’s 1871 Long Form Table

For decades after its publication, this short table was frequently referred to as “Mendeleev’s table” and updated versions were often be described as being

periodische Gesetzmäßigkeit der chemischen Elemente,” *Annalen der Chemie*, supp. 8 (1871): 144, <https://books.google.com/books?id=vpJbtTjj8ZYC>.

<sup>233</sup> Mendeleef, “The Periodic Law,” 268; Mendelejeff, “Die periodische,” 148.

“after” Mendeleev’s 1871 table. Meyer’s atomic volume curve was also extremely popular among chemists. These visual representations were originally created by Meyer and Mendeleev for pedagogical purposes, and they continued to be used in that context. However, these representations also became integral to the understanding, acceptance, and further development of the periodic law by chemists in the years immediately following its discovery.

### **Problems Elemental**

A topic of considerable debate within the philosophy of science today concerns why new theories and laws are accepted by scientists. Are they accepted because they make predictions which are then fulfilled, or because they accommodate data which was already known? In other words, prediction or accommodation? This is a large on-going debate, worthy of a discussion of its own.<sup>234</sup> Traces of a related, though not identical, debate can be found within the scientific literature of the late nineteenth century. How much, chemists wondered, should we accept this new theory of the periodic law over the facts which are known from experimental evidence?

Chemistry was a practical science, characterized by “the use of fingers in the laboratory” and “contact with actual materials,” rather than by mathematics and

---

<sup>234</sup> The literature on accommodation vs. prediction with regard to the periodic table is growing. Brush, “Reception,” comes down on the side of prediction. Scerri and Worrall, on the other hand, argue that accommodation was just as important as prediction; see Eric R. Scerri and John Worrall, “Prediction and the Periodic Table,” *Studies in History and Philosophy of Science* 32 (2001): 407-452, doi:10.1016/S0039-3681(01)00023-1. Both of these articles touched off a series of responses, still ongoing, most of which can be found in the journals *Studies in History and Philosophy of Science* and *Foundations of Chemistry*.

theorizing.<sup>235</sup> By the 1870s, however, this was changing as instruments and techniques drawn from physics were increasingly being used in the study of the elements. As the following case studies indicate, it was not necessarily an either/or choice between experimental evidence and theory in deciding whether or not to accept the periodic law, and chemists grappled with their positions over the last quarter of the nineteenth century. Along with experiment, chemists began to use the periodic table – usually “Mendeleev’s table” – to determine if the new theory was acceptable.

### **The Discovery of Gallium and Scandium**

In August of 1875, the French chemist Pierre Emil Lecoq de Boisbaudran announced the discovery of a new element, which he named gallium in honor of France.<sup>236</sup> Mendeleev read of Boisbaudran’s discovery and quickly submitted a note to the *Comptes Rendus*. He began by reminding readers that in 1869 he had proposed the periodic law and included a short form table to illustrate that the “law constitutes the basis of a complete systematic classification of the elements.”<sup>237</sup>

---

<sup>235</sup> Henry E. Armstrong, “The Nature of Chemical Change,” *Chemical News* 99 (1909): 28, <https://hdl.handle.net/2027/mdp.39015073139308?urlappend=%3Bseq=34>.

<sup>236</sup> Lecoq de Boisbaudran, “Caractères chimiques et spectroscopiques d’un nouveau métal, le *Gallium*, découvert dans une blende de la mine de Pierrefitte, vallée d’Argelès (Pyrénées),” *Comptes Rendus Hebdomadaires des Séances de l’Académie des Sciences* 81 (1875): 493-495,

<https://hdl.handle.net/2027/uc1.31822009517228?urlappend=%3Bseq=501>.

<sup>237</sup> D. Mendeleeff, “Remarks on the Discovery of Gallium,” *Philosophical Magazine* 5<sup>th</sup> ser., 1 (1876): 542,

<https://hdl.handle.net/2027/njp.32101075715175?urlappend=%3Bseq=564>. D. Mendeleeff, “Remarques à propos de la découverte du gallium,” *Comptes Rendus Hebdomadaires des Séances de l’Académie des Sciences* 81 (1875): 969,

<https://hdl.handle.net/2027/uc1.31822009517228?urlappend=%3Bseq=977>; “Cette loi...”.



Mendeleev stated that he had left a space on the table for an as-yet-undiscovered element, eka-aluminium. The properties he predicted for this element agreed more or less with those of the new element gallium that Boisbaudran had just discovered: “If subsequent researches confirm the identity of the properties of gallium with those which I have pointed out as belonging to eka aluminium, the discovery of this element will furnish an interesting example of the utility of the periodic law.”<sup>238</sup>

Boisbaudran, however, denied he had been aware of Mendeleev’s periodic law: “I will even add that this ignorance may perhaps have been advantageous to me, for I should have experienced serious delays if I had been led to seek for gallium in the precipitates formed by ammonia, and not in the ammoniacal solutions in which it is in feeble quantity.”<sup>239</sup> Rather, Boisbaudran had used his own classification scheme.<sup>240</sup> Although he acknowledged that many of the predictions made by Mendeleev about specific characteristics of gallium were correct, Boisbaudran was not willing to go so far as to endorse Mendeleev’s periodic law over any other classification scheme for the elements: “However, the discovery of the new metal gives to the classifications predicting the existence of unknown

---

<sup>238</sup> Mendelejeff, “Remarks,” 545. Mendeleeff, “Remarques,” 971; “Si les recherches...”.

<sup>239</sup> Lecoq de Boisbaudran, “On the new metal – gallium,” *Chemical News* 35 (1877): 170, <https://hdl.handle.net/2027/nyp.33433062749308?urlappend=%3Bseq=164>. Lecoq de Boisbaudran, “Sur un nouveau métal, le gallium,” *Annales de Chimie et de Physique* 5<sup>th</sup> ser., 10 (1877): 139, <https://hdl.handle.net/2027/hvd.hx3e1k?urlappend=%3Bseq=104>; “J'ajouterai même que cette ignorance...”.

<sup>240</sup> Boisbaudran frequently mentioned his classification scheme but did not publish any details until 1895. See “Classification des éléments chimiques,” *Comptes Rendus Hebdomadaires des Séances de l'Académie des Sciences* 120 (1895): 1097-1103, <https://hdl.handle.net/2027/uc1.31822009517673>.

elements an importance which it was impossible, I think, to accord to them until they had been verified by some positive fact.”<sup>241</sup>

While Boisbaudran was not accepting of the periodic law, many chemists were – to one degree or another. In an 1877 paper, the Scottish chemist M. M. Pattison Muir drew up a table comparing the properties of gallium and its salts with the properties of Mendeleev’s predicted eka-aluminium as well as with aluminium and indium, between which Mendeleev had placed eka-aluminium in his tables. “M. de Boisbaudran does not apparently altogether accept the position assigned to ekaaluminium for his new metal gallium,” Pattison Muir noted. He himself did not advocate accepting that eka-aluminium and gallium were the same element without further research. However, he did believe that this research should “take the direction indicated by the hypothetical properties of ekaaluminium.” Pattison Muir ended with the declaration, “Mendelejeff’s hypothesis is at least of much value as a guide to future research.”<sup>242</sup>

Pattison Muir’s somewhat qualified acceptance of the periodic law is perhaps explained in his essay on chemical classification, published later the same year as his paper on gallium. In the essay, Pattison Muir described the criteria for a good chemical classification. “If we trace back the history of chemical theory, we find that chemists have ever been attempting to connect together in a definite manner a

---

<sup>241</sup> Lecoq de Boisbaudran, “On the new metal – gallium,” 170. Lecoq de Boisbaudran, “Sur un nouveau métal,” 140; “Cependant la découverte du nouveau...”.

<sup>242</sup> M. M. Pattison Muir, “Observations on Gallium,” *Philosophical Magazine* 5<sup>th</sup> ser., 3 (1877): 282, <https://hdl.handle.net/2027/wu.89048311674?urlappend=%3Bseq=293>.

variable and a variant.” Pattison Muir continued that Mendeleev’s system had the advantage of providing “a definite variable, viz. atomic weight; and it attempts to represent the physical and chemical properties, both of elements and compounds, as functions of this variable.” However, Pattison Muir believed that it would also lead to more questions and that is was “only when we shall have attained to a much wider knowledge of the connexions existing between composition and properties of chemical bodies that any attempt at a large scheme of classification likely to prove of lasting value needs to be made.”<sup>243</sup>

Other chemists were much firmer in their advocacy of the periodic law. The English chemist Henry E. Armstrong wrote the inorganic chemistry section of the ninth edition of the *Encyclopaedia Britannica* entry on chemistry.<sup>244</sup> The entry was part of the fifth volume, published in 1876, only a year after Boisbaudran’s discovery of gallium. Not only was gallium included in the listing of elements, but Armstrong included a section on the “Periodic Relations of the Elements,” which is almost entirely about Mendeleev’s periodic law and Lothar Meyer’s atomic volume curve. Armstrong asserted: “The establishment of the periodic law may truly be

---

<sup>243</sup> M. M. Pattison Muir, “On Chemical Classification,” *Philosophical Magazine* 5<sup>th</sup> ser., 4 (1877): 269-270, 271,

<https://hdl.handle.net/2027/wu.89048311682?urlappend=%3Bseq=93>.

<sup>244</sup> [Henry E.] Armstrong, Raphael Meldola, and F. H. Butler, “Chemistry,” in *The Encyclopaedia Britannica*, Original Ninth Edition in Twenty-Five Volumes, In Thirty Volumes With New American Supplement (New York: The Werner Company, 1902), 5:459-579,

<https://hdl.handle.net/2027/uc2.ark:/13960/t6tx3m15n?urlappend=%3Bseq=471>

said to mark an era in chemical science, and we may anticipate that its application and extension will be fraught with the most important consequences.”<sup>245</sup>

*Arrangement of Elements in the order of their Atomic Weights.*

H 1	Li 7	Na 23	K 39	Cu 63	Rb 85	Ag 108	Cs 133	...	Au 199	...	RCl
	Be 9.4	Mg 24	Ca 40	Zn 65	Sr 87	Cd 112	Ba 137	...	Hg 200	...	RCl <sub>2</sub>
	B 11	Al 27	...	Ga 68	Y 88	In 113	Di 138	Eb 178	Tl 204	...	RCl <sub>3</sub>
	C 12	Si 28	Ti 48	...	Zr 90	Sn 118	Ce 140	La 180	Pb 207	Th 231	RCl <sub>4</sub>
	N 14	P 31	V 51	As 75	Nb 94	Sb 122	...	Ta 182	Bi 210	...	RCl <sub>5</sub>
	O 16	S 32	Cr 52	Si 78	Mo 96	Te 125?	...	W 184	...	U 240	RCl <sub>6</sub>
	F 19	Cl 35.5	Mn 55	Br 80	...	I 127	...	...	...	...	RCl <sub>7</sub>
			Fe 56	...	Ru 104	...	...	Os 195			
			Co 59	...	Rh 104	...	...	Ir 197			
			Ni 59	...	Pd 106	...	...	Pt 198			
			Cu 63	...	...	...	...	...			

**Figure 3.8: Table in Fownes' Manual (12th ed.)**

While *Britannica* was presumably written for any interested lay person, the more specialized chemical handbooks were also beginning to embrace the periodic law in the wake of the discovery of gallium. The periodic law was included in the twelfth edition of *Fownes' Manual of Chemistry: Theoretical and Practical*, published in 1877.<sup>246</sup> The review of this latest edition in the journal *Nature* noted:

Among the more important additions we may mention an account of Mendeleeff's Laws of Periodicity, and a very good digest of what is known concerning the new metal gallium and its compounds; this element is associated with indium, with the probable atomic weight 68, as already indicated by M. Mendeleeff.<sup>247</sup>

Henry Watts, who had taken over the writing of *Fownes' Manual*, did not give sole credit to Mendeleev for the periodic law, mentioning that Newlands was the first to

<sup>245</sup> Armstrong, Meldola, and Butler, "Chemistry," 5:544.

<sup>246</sup> Henry Watts, *Fownes' Manual of Chemistry: Theoretical and Practical*, 12<sup>th</sup> ed. (London: J. & A. Churchill, 1877), 1:264-268, <https://hdl.handle.net/2027/wu.89097708622>.

<sup>247</sup> T., "Fownes's Inorganic Chemistry," review of *Fownes's Inorganic Chemistry*, ed. Henry Watts, *Nature* 16 (1877): 6, doi:10.1038/016006a0.

point out the periodic law and that it had been further developed by Odling and Mendeleev. However, the table included bears more resemblance to a Mendeleev table than to ones drawn by either Newlands or Odling and includes blank spaces for as-yet-undiscovered elements (Fig. 8). Watts did credit Mendeleev with the successful prediction of gallium.<sup>248</sup>

The discovery of Mendeleev's eka-aluminium certainly brought the periodic law to the attention of many chemists, even if it did not convince them of the truth of the law. The discovery of another predicted element provided further evidence and prompted more intent interest among chemists. In 1879, the Swedish chemist L. F. Nilson discovered a new element amongst gadolinite and euxenite, minerals largely found only in Scandinavia, in honor of which Nilson named the element scandium.<sup>249</sup> Like Boisbaudran, Nilson was apparently unaware of Mendeleev's predictions, however the Swedish chemist Per Clève made the connection between Nilson's scandium and Mendeleev's predicted eka-boron. In a paper in the *Comptes Rendus*, Clève reported on his own research which confirmed Nilson's discovery.<sup>250</sup> Clève concluded: "The great interest of scandium is that its existence has been predicted. Mendeleef, in his memoir on the law of periodicity, had foreseen the existence of a metal which he named ekabor, and whose characters agree very fairly with those of

---

<sup>248</sup> Watts, *Fownes'*, 265, 268.

<sup>249</sup> L. F. Nilson, "Ueber Scandium, ein neues Erdmetall," *Berichte der deutschen chemischen Gesellschaft* 12 (1879): 554-557, <https://hdl.handle.net/2027/umn.31951000682712e?urlappend=%3Bseq=620>.

<sup>250</sup> P. Clève, "Sur le scandium," *Comptes Rendus Hebdomadaires des Séances de l'Académie des Sciences* 89 (1879): 419-422, <https://hdl.handle.net/2027/nyp.33433009682646?urlappend=%3Bseq=425>.

scandium.”<sup>251</sup> Clève provided a table that favorably laid out the comparisons between scandium and eka-boron.

This second discovery provoked great and renewed interest in the periodic law. Mendeleev took the opportunity to send a French translation of his 1871 paper to the journal *Le Moniteur Scientifique*, with an accompanying letter.<sup>252</sup> In this letter, Mendeleev indicated the flexibility of the periodic law, as well as its ability to be strengthened by both experiment and philosophy. “The formula of the law might be changed,” he stated, “but, I believe that the original idea of the periodic law will remain.” Mendeleev hoped that the renewed attention of chemists would “endeavour to bring as the first fruits of the periodic law a new philosophical order, in fixing it by pillars strengthened by new experiments so as to give greater stability to the edifice already begun.”<sup>253</sup> A part of this edifice was the visual representation of the periodic law in the form of a table. The original paper in the *Annalen der Chemie* contained two tables (see Figs. 6 and 7) and Mendeleev included a new table in the letter (Fig. 8), which he said illustrated “[t]he best way of drawing up the table of elements, so as to show the periodic relations.”<sup>254</sup> Though he added the

---

<sup>251</sup> P. Clève, “On Scandium,” *Chemical News* 40 (1879): 160, <https://hdl.handle.net/2027/wu.89100444694?urlappend=%3Bseq=169>. Clève, “Sur le scandium,” 421; “Ce qui rend la découverte du scandium...”.

<sup>252</sup> D. Mendeleeff, “La Loi Périodique des Éléments Chimiques,” *Le Moniteur Scientifique* 3<sup>rd</sup> ser., 9 (1879): 691-737, <https://gallica.bnf.fr/ark:/12148/bpt6k215202c/f690.item>. This was then translated into English and published in *Chemical News*; see Mendeleef, “Periodic Law.”

<sup>253</sup> Mendeleef, “Periodic Law,” 40 (1879): 231.

<sup>254</sup> Mendeleef, “Periodic Law,” 40 (1879): 231.

disclaimer, “I think,” or “in my opinion,”<sup>255</sup> leaving open the possibility that as the periodic law was developed so to would its visual representation.

							I	II	III	IV	V	VI	VII			
							—	—	—	—	—	—	—			
							H									
ÉLÉMENTS TYPIQUES.							{	Li;	Be;	B;	C;	N;	O;	F;		
							{	Na								
							ÉLÉMENTS IMPAIRS									
ÉLÉMENTS PAIRS																
I	II	III	IV	V	VI	VII										
—	—	—	—	—	—	—										
K	Ca	..	Ti	V	Cr	Mn	Fe	Co	Ni	Cu	Zn	Ga	..	As	Se	Br
Rb	Sr	Yt	Zr	Nb	Mo	..	Ru	Rh	Pd	Ag	Cd	In	Sn	Sb	Fe	I
Cs	Ba	La	Ce	..	..	..	..	..	..	..	..	..	..	..	..	..
..	..	Er	Di?	Ta	W	..	Os	Ir	Pt	Au	Hg	Tl	Pb	Bi	..	..
..	..	..	Th	..	Ur	..	..	..	..	..	..	..	..	..	..	..

**Figure 3.9: Mendeleev's 1879 Table**

The *Chemical News* quickly printed an English translation of the letter Mendeleev sent to *Le Moniteur Scientifique*, along with the paper. This publication included an editor's note stating:

Considerable attention having been drawn to M. Mendeleef's memoir 'On the Periodic Law of the Chemical Elements,' in consequence of the newly discovered elements gallium and scandium being apparently identical with his two predicted elements ekaluminium and ekaboron, it has been thought desirable to reproduce the entire article in the *Chemical News*.<sup>256</sup>

The *Chemical News* serialized the paper, thereby keeping Mendeleev and his formulation of the periodic law before the gaze of readers from November 1879 to March 1880.

<sup>255</sup> The English translation used the phrase “I think” while Smith used “in my opinion”; John Russell Smith, “Persistence and Periodicity: A Study of Mendeleev's Contribution to the Foundations of Chemistry,” PhD diss., Chelsea College, 1976: 288. The French phrase used was “à mon avis”; Mendeleeff, “La Loi,” 692.

<sup>256</sup> Mendeleef, “Periodic Law,” 40 (1879): 231.

## The Atomic Weight of Beryllium

Mendeleev did more than predict several elements when he developed the periodic law. He also changed the atomic weight of several elements to make them better fit within the system. One of those he changed was that of beryllium. From its discovery in 1797, beryllium had been the subject of repeated debates. The element was most known as beryllium, however most French chemists referred to it as glucinum. Its atomic weight was also frequently under debate. In a memoir on beryllium, the American chemist Charles Lathrop Parson described the 1870s and 1880s as a time during which “a long, earnest and interesting discussion” occurred “regarding the valency of beryllium and its place in the periodic system.”<sup>257</sup>

The valency of an element helped in determining its atomic weight. Mendeleev believed beryllium was divalent (had a valency of 2) which suggested that it had an atomic weight of approximately 9. However, experiments over the course of many years led most chemists to believe that beryllium had a valency of 3, which increased estimates of its atomic weight to greater than 13.5 (most numbers ranged between 13.65 and 13.8). A different valency and atomic weight would put the element into a different place within the periodic system, making its physical characteristics align with different sets of elements. Mendeleev argued that beryllium and its compounds behaved more like magnesium, while other chemists argued for its analogy with aluminium. Experimental evidence, however, revealed

---

<sup>257</sup> Charles Lathrop Parsons, *The Chemistry and Literature of Beryllium* (Easton, PA: The Chemical Publishing Co., 1909): 2, <https://books.google.com/books?id=7MxAAAAAIAAJ>.



that some compounds of beryllium behaved more like those of magnesium while others behaved more like those of aluminium.

Beryllium was a problem that tested the truth of the periodic law. Were chemists to believe in the evidence presented to them by experiment? Or did they trust in the theory that was the periodic system? The Swedish chemists Nilson and Pettersson, who did extensive work on metals such as beryllium and the rare earths, announced in an 1880 paper that their experiments led them to conclude the atomic weight of beryllium was 13.65, not the 9 that was indicated by the periodic law: "In consequence of what has been indicated here, the periodic law in its present condition cannot be said to be quite an adequate expression of our knowledge of the elements." Despite their conclusion, they were optimistic about the future of the periodic law: "this theory, however, having given the most striking proofs that the truth in many respects has been found ..., we may expect that the periodic law may be so modified and developed that it can embrace and explain every fact stated by experiment."<sup>258</sup>

In a similar vein, the American chemist James Blake found that beryllium was a member of the aluminium group, not the magnesium group as indicated by Mendeleev.<sup>259</sup> He wondered if, perhaps:

[t]he fact that a substance is required with an atomic weight of about 9 to fill a vacant place in the Mendelejeff series of elements, and that whether beryllium can fill this place is regarded, *als eine letenspage* [sic] *des*

---

<sup>258</sup> L. F. Nilson and Otto Pettersson, "On the Essential Properties and Chemical Character of Beryllium (Glucinum)," *Chemical News* 42 (1880): 299, <https://hdl.handle.net/2027/njp.32101075379477?urlappend=%3Bseq=307>.

<sup>259</sup> James Blake, "On the Atomic Weight of Beryllium as Determined By Its Physiological Action," *Chemical News* 45 (1882): 111, <https://hdl.handle.net/2027/wu.89100444736?urlappend=%3Bseq=119>.

*periodischen systems* ..., has perhaps unconsciously influenced the judgment of the strenuous supporters of this law in weighing the evidence.<sup>260</sup>

In other words, were supporters of Mendeleev's periodic law attempting to make facts fit into theory, regardless of experimental evidence?

The German phrase Blake quoted came from a paper by Bohuslav Brauner in which Brauner declared that atomic weight of beryllium was "*als eine Lebensfrage des periodischen systems*" [as a vital question of the periodic system].<sup>261</sup> Brauner, a Czech chemist, was one of the earliest supporters of Mendeleev's periodic system and spent most of his career attempting to prove that the changes Mendeleev had made in atomic weights, including that of beryllium, were correct.<sup>262</sup> Brauner was not the only chemist who sided with the theory of the periodic system over the facts of experimental evidence, but he was one of the few who believed in it from the beginning.

Unlike Brauner, the English chemist T. S. Humpidge was more inclined to side with the experimental facts when it came to the atomic weight of beryllium. In an 1880 paper, he surveyed the experimental research that had to date been conducted to determine the atomic weight of beryllium. He decried what he saw as attacks by supporters of the periodic law on those chemists whose experimental results did

---

<sup>260</sup> Blake, "On the Atomic Weight," 111.

<sup>261</sup> Bohuslav Brauner, "Ueber das Atomgewicht des Berylliums," *Berichte der deutschen chemischen Gesellschaft* 14 (1881): 54, <https://hdl.handle.net/2027/mdp.39015026349442?urlappend=%3Bseq=57>.

<sup>262</sup> Mendeleev valued Brauner's work on the rare earth elements so highly that he asked Brauner to write that section of the *Principles of Chemistry* beginning with the 7<sup>th</sup> edition. See J. H., "Prof. Bohuslav Brauner," *Nature* 135 (1935): 497-498, doi:10.1038/135497a0; Smith, "Persistence," 431.

not align with that theory. “[S]hall we accept the fact or the theory?” Humpidge asked. He reminded his readers:

[I]f the theory is accepted and the fact rejected, they are in the position of the supporters of some of the earlier chemical theories, when once they found that a theory which had for a considerable time satisfied their wants was no longer sufficient to explain new facts, they preferred to retain the theory and to explain the facts as best they could. I am not arguing for the rejection of the periodic law, but only wish to show that if facts are discovered which are incompatible with it, it must of necessity receive some modification.<sup>263</sup>

Facts, then, should not be rejected just to support a new theory. In forming a judgment on which atomic weight should be accepted, Humpidge took into consideration the methods used, the apparatus employed, the accuracy of measurements, and the accountability for impurities, among other factors. Concluding his survey, he decided that Nilson and Pettersson’s most recent experimental results should be accepted but should also be confirmed by another chemist.

Humpidge undertook his own experiments to determine the atomic weight of beryllium, for which he obtained a grant of £50 from the Royal Society to defray the cost of material and apparatus.<sup>264</sup> He began by attempting to obtain a purer metal sample than that of Nilson, and then to redetermine its specific heat. In his 1883 report to the Royal Society, Humpidge carefully described the processes and apparatus he used, indicating the points at which there were potential problems. Ultimately, the specific heat he measured was slightly higher than that of Nilson. But even if his results were “erroneous to the extent of 10 per cent.,” he stated, “it is

---

<sup>263</sup> T. S. Humpidge, “On the Atomic Weight of Beryllium,” *Chemical News* 42 (1880): 263, <https://hdl.handle.net/2027/njp.32101075379477?urlappend=%3Bseq=271>.

<sup>264</sup> “Anniversary Meeting,” (1882-1883): 340.

still certain that the specific heat of the metal is nothing near 0.6 as it ought to be if the atomic weight were 9.1." Humpidge concluded: "The result is unfortunate for the periodic law, and is the first serious rebuff which this useful generalisation of facts has received."<sup>265</sup>

Humpidge's work was the subject of criticism – mostly by those who he himself had criticized – but he continued his research. Next he determined the specific heat of beryllium at varying temperatures, as well as the vapour-density of volatile beryllium compounds. The ultimate results of this research astonished him. In determining the specific heat in a greater range of temperatures than his previous experiment, he now had obtained a result of an atomic weight of 9.1, forcing him to conclude, "It is therefore clear this number represents the true atomic weight, and not 13.6, as was previously deduced."<sup>266</sup> The results of the vapour density experiments also yielded an atomic weight of 9.1 Humpidge declared:

The long disputed question of the atomic weight of glucinum is thus definitely and finally decided in favour of that number which satisfies the requirements of the periodic law, and another element is added to the long list of those whose atomic weights have been corrected by this important generalisation.<sup>267</sup>

---

<sup>265</sup> T. S. Humpidge, "On the Atomic Weight of Glucinum (Beryllium)," *Philosophical Transactions of the Royal Society of London* 174 (1883): 613, <http://www.jstor.org/stable/109419>.

<sup>266</sup> T. S. Humpidge, "On the Atomic Weight of Glucinum (Beryllium). Second Paper," *Proceedings of the Royal Society of London* 39 (1885): 9, <http://www.jstor.org/stable/114166>.

<sup>267</sup> Humpidge, "On the Atomic Weight of Glucinum (Beryllium). Second Paper," 13-14.

If he had fully recognized the importance of the periodic system before he began his research, Humpidge wrote, "I should perhaps have stated my conclusions and criticisms less positively than I did."<sup>268</sup>

Humpidge did not blindly accept theory over fact, nor fact over theory. Rather, his research ultimately concluded that it was important to give both theory and experiment due consideration: "In all future determinations of the atomic weight of an element, the position which the element should occupy in the periodic arrangement must receive due importance."<sup>269</sup> This combination of prediction and accommodation worked for many chemists. It was similar to a general position advocated by Lothar Meyer in his textbook *Modernen Theorien*: "...in chemistry one will more and more be in the position, as is now the case in physics, to always keep in view the dependence between each hypothesis and the results of observation compared with theoretical consequences."<sup>270</sup> Historian Michael Gordin described this position as "a middle ground" between "the restrained utility of theory" and "unrestrained empiricism."<sup>271</sup>

However, Mendeleev's periodic system still had flaws. Many of the elements in Group VIII were considered to be anomalous. In the colorful language of the American chemist James Lewis Howe: "The seeming impossibility of reconciling these nine metals with the periodic law is undoubtedly the reason why they were thrown into a single group; dumped into a chemical Gehenna as it were, while the

---

<sup>268</sup> Humpidge, "On the Atomic Weight of Glucinum (Beryllium). Second Paper," 14.

<sup>269</sup> Humpidge, "On the Atomic Weight of Glucinum (Beryllium). Second Paper," 14.

<sup>270</sup> Meyer, *Die modernen Theorien*, 144; quoted in Gordin, "The Textbook Case," 71.

<sup>271</sup> Gordin, "The Textbook Case," 71.

rest of the elements were reduced to orderly arrangement.”<sup>272</sup> The rare earths were also problematic, being difficult to work with and to definitively identify, and were uneasily placed within the periodic system. But despite its flaws, the periodic system had been shown through experiment to be a useful theory – and a useful tool to assist in researching the problematic elements.

### **The Unity of Matter**

On 18 February 1887, Sir William Crookes gave an address before the Royal Institution on the topic of the elements. “These elements,” he proclaimed, “perplex us in our researches, baffle us in our speculations, and haunt us in our very dreams. They stretch like an unknown sea before us – mocking, mystifying, and murmuring strange revelations and possibilities.”<sup>273</sup> In the present time of “restless inquiry,” he asked the audience, “what are these elements, whence do they come, what is their signification?”<sup>274</sup> Crookes believed the current state of chemical science was not capable of answering these basic questions. These uncertainties combined with new experimental techniques, such as spectroscopy and fractionation, left the door open to a revival of modified forms of Prout’s hypothesis, as well as to other visions of the unity of matter. Once it was firmly established, the periodic law was used to bolster many ideas about the elements.

---

<sup>272</sup> Jas. Lewis Howe, “The Eighth Group of the Periodic System and Some of Its Problems,” *Science*, n.s., 12 (1900): 20-21, <http://www.jstor.org/stable/1627722>.

<sup>273</sup> This sentence is often misquoted as starting, “The rare earth elements...” rather than “These elements...” It is clear from the context that Crookes spoke of all of the elements, not one particular group of elements.

<sup>274</sup> William Crookes, “Genesis of the Elements,” *Notices of the Proceedings at the Meetings of the Members of the Royal Institution of Great Britain* 12 (1889): 37, [https://hdl.handle.net/2027/uc1.\\$b522692?urlappend=%3Bseq=51](https://hdl.handle.net/2027/uc1.$b522692?urlappend=%3Bseq=51).

## The Problem With Elements

One of the most basic, and continually controversial, issues chemists encountered was just what constituted an element. The working definition was still that of Lavoisier, published in his 1789 textbook *Elements of Chemistry*. An element was “all the substances into which we are capable, by any means, to reduce bodies by decomposition.” This sounds clear enough; any substance which cannot be decomposed into more than one substance is an element. But, he continued:

since these principles cannot be separated, or rather since we have not hitherto discovered the means of separating them, they act with regard to us as simple substances, and we ought never to suppose them compounded until experiment and observation has proved them to be so.<sup>275</sup>

This was hardly unambiguous, leaving as it did room for the possibility that substances presently believed to be elements, to be composed of a single substance, could in the future be found as a result of new analytical techniques to be compounds.

The history of didymium exemplified this possibility. In 1841, the Swedish chemist Carl Mosander discovered what he believed to be an element, didymium. In 1874, however, using spectroscopic techniques that had been unavailable when Mosander made his discovery, Clève theorized that didymium was a compound made up of more than one element. Five years later, Boisbaudran isolated the element samarium from a sample of didymium.<sup>276</sup> The Austrian chemist Carl Auer

---

<sup>275</sup> Lavoisier, *Elements of Chemistry*, trans. Robert Kerr (Edinburgh, 1790), xxiv, <https://hdl.handle.net/2027/gri.ark:/13960/t5v735k9h>. Lavoisier, *Traité élémentaire de chimie* (Paris: Chez Cuchet, 1789), 1: xvii-xviii, <https://hdl.handle.net/2027/mdp.39015005319481>.

<sup>276</sup> Lecoq de Boisbaudran, “Recherches sur le samarium, radical d’une terre nouvelle extraite de la samarskite,” *Comptes Rendus Hebdomadaires des Séances de l’Académie*

von Welsbach, using fractional crystallization, another new technique, succeeded in 1885 in separating two more elements from didymium, which he named neodymium and praseodymium.<sup>277</sup> What had been thought to be an element was actually a compound of three elements. This was not the only such case. While chemists had become accustomed to this malleability in the definition of an element, it did not necessarily inspire confidence in the idea of elements, substances that could not be decomposed into any other substance.

The “so-called elements” were a popular topic for speeches and papers in the last quarter of the nineteenth century. An example of a typical paper is one written by the American chemist Frank Wigglesworth Clarke. In 1876, he posed the question for the readers of *Popular Science Monthly*: “What are the so-called chemical elements? Are they really elements, or only compounds of remarkable stability?”<sup>278</sup> Scientists “need a convenient working hypothesis” and so accepted that the sixty-three substances currently known as elements are such. Yet they could not prove beyond a doubt either that these elements were elementary or that they were compounds. After laying out the arguments for both viewpoints, Clarke concluded, “Atomic weights, specific volumes, and spectra, all unite in telling the same story, that our many elements have been derived from simpler stock.”<sup>279</sup>

---

*des Sciences* 89 (1879): 212-214,  
<https://hdl.handle.net/2027/uc1.31822009517434?urlappend=%3Bseq=218>.

<sup>277</sup> Carl Auer v. Welsbach, “Die Zerlegung des Didyms in seine Elemente,”  
*Monatshefte für Chemie* 6 (1885): 477-491,  
<https://hdl.handle.net/2027/uc1.b3483664?urlappend=%3Bseq=493>.

<sup>278</sup> F. W. Clarke, “Are the Elements Elementary?,” *Popular Science Monthly* 8 (1876):  
463, <https://hdl.handle.net/2027/nyp.33433062734631?urlappend=%3Bseq=509>.

<sup>279</sup> Clarke, “Elements,” 464, 471.



The belief that the elements derived from a single primary matter, or from a small set of primary matters, was also the result of another issue confounding chemists: there were too many new elements being discovered. Element discoveries seem to occur in groups and the last decades of nineteenth century were in the midst of such a phase. The rare earth elements were particularly troublesome in this regard; being so similar chemically, they were extremely difficult to separate which led to the “discovery” of ever more of them. Humpidge was appalled at the fact that there had been claims of fourteen new elements within the space of only two years, the majority of them belonging to the yttrium and cerium groups. He strongly suggested that chemists defer the announcement, much less the acceptance, of “new” elements until there was strong experimental evidence to support the claim: “No discovery of such importance as that of a new element should be generally accepted until it has been submitted to a series of rigorous confirmatory tests.” As for those fourteen new elements? “Time alone will prove how many ... will pass the ordeal of further and perhaps more rigorous investigations.”<sup>280</sup>

Others had a more philosophical response to the proliferation of simpler substances, one of which in many ways echoed of that of early nineteenth century chemists who had also experienced a similar explosion of new elements. In the first years of the century, Thomas Thomson suggested to his readers, “the number of

---

<sup>280</sup> T. S. Humpidge, “New Metals,” *Nature* 22 (1880): 233, doi:10.1038/022232a0. Only about one third of the fourteen new elements mentioned by Humpidge appear on the periodic table today.

simple substances will probably be much smaller than at present.”<sup>281</sup> Likewise, Humphry Davy believed “there is reason to anticipate a great reduction in the number of the undecomposed bodies.”<sup>282</sup> Davy disliked the word element, uneasy about the ambiguity implied by Lavoisier's definition. He felt, much as Clarke did in 1876, that nature was not so complex as to require a large and ever increasing number of elements. But in Clarke's time there was a new theory that some thought could provide a solution. Darwin's theory of evolution was the subject of much conversation, argument, and debate, as it was beginning to be applied to things such as societies, cultures, and religions.<sup>283</sup> In a letter in the *Chemical News*, Sceptical Chymist said of the numerous “new elements” that were being announced, “Probably only the ‘fittest’ will ‘survive.’”<sup>284</sup> If plants and animals had evolved from much simpler forms, then why not the elements?

### **Prout Revived**

The ever expanding list of new elements, the unease over the ability to definitively determine whether an element was indeed an element, and the acceptance of new methods such as spectroscopy and fractionation to identify elements led some chemists to new ideas regarding the unity of matter. One of the

---

<sup>281</sup> Thomas Thomson, *A System of Chemistry*, vol. 1 (Edinburgh, 1802), 386, <https://hdl.handle.net/2027/uc1.aa0001914969>.

<sup>282</sup> Humphry Davy, *The Collected Works of Sir Humphry Davy*, ed. John Davy, vol. 4 (London: Smith, Elder and Co., 1840), 42, <https://hdl.handle.net/2027/hvd.32044021235262>.

<sup>283</sup> The first use of the phrase ‘social Darwinism’ in print occurred in 1877. See Joseph Fisher, “The History of Landholding in Ireland,” *Transactions of the Royal Historical Society* 5 (1877): 250, <http://www.jstor.org/stable/3677953>.

<sup>284</sup> Sceptical Chymist, “New Elements,” *Chemical News* 40 (1879): 133, <https://hdl.handle.net/2027/wu.89100444694?urlappend=%3Bseq=143>.

most discussed ideas, though not universally accepted, was that of Crookes. In his 1887 address before the Royal Institution, Crookes posited what he called the genesis of the elements. Crookes's hypothesis was built on the work of others, most notably that of English scientist J. Norman Lockyer who in 1878 had shocked many members in attendance at the Royal Society with his dissociation hypothesis.<sup>285</sup> The elements, Lockyer stated, were compound bodies, composed not only of atoms but of subatoms which produced their own characteristic spectral lines. This hypothesis explained why the spectra of some elements seemed to have lines in common. Lockyer also believed he had found experimental evidence that suggested elements of larger atomic weights dissociated at high temperatures into elements of lower atomic weights. This implied that there were only a small number of true elements.

While Lockyer's hypothesis regarding the composition of the elements evoked little enthusiasm among scientists, Crookes seized on the dissociation idea as the basis for his hypothesis of the evolution of the elements. Crookes concluded "that our so called elements or simple bodies are, in reality, compound molecules. To form a conception of their genesis," he enjoined his audience:

I must beg you to carry your thoughts back to the time when the visible universe was 'without form and void,' and to watch the development of matter in the states known to us from an antecedent something. What existed anterior to our elements, before matter as we now have it, I propose to name *protyle*.

---

<sup>285</sup> J. N. Lockyer, "Researches in Spectrum Analysis in Connexion With the Spectrum of the Sun. No. VII," *Proceedings of the Royal Society of London* 28 (1878-1879): 157-180, <http://www.jstor.org/stable/113812>. For an account of the meeting, reprinted from *The Times* of London, see "The Nature of the Elements," *Chemical News* 38 (1878): 291-292, <https://hdl.handle.net/2027/inu.30000088771401?urlappend=%3Bseq=583>.

At the very beginning of time, the universe was in an ultra-gaseous state. As the universe began to cool, atoms of *protyle* coalesced into the elements of lower atomic weight, which then further combined into elements with heavier atomic weights.<sup>286</sup> Each atom of a particular element had a mean atomic weight, that is not all atoms of, for example, calcium had an atomic weight of 40 but rather some had a weight of 39.8, others 39.9, still others 40.1, and so on. Crookes acknowledged that this “speculation” might seem “hazardous” but had some experimental support.<sup>287</sup> The symmetry of most of the series of elements, when arranged in a table similar to that of Mendeleev, “proclaims at once that we are working in the right direction.”<sup>288</sup> The arrangement of the elements, Crookes proclaimed, held “the key to unlock some of the deepest mysteries of creation.”<sup>289</sup>

Reactions to these ideas were mixed. British and American chemists were more likely to be accepting than chemists on the continent. Jean Charles Marignac, the Swiss chemist, had redetermined the atomic weights of several elements in the 1840s and concluded that, although Prout’s hypothesis could not be confirmed it was possible that the real multiple might be that of half the weight of hydrogen, rather than the full weight of hydrogen as Prout had suggested. Marignac was, then, not against a hypothesis of the unity of matter. However, he did not condone Crookes’s hypothesis of the genesis of the elements. In a lengthy paper, Marignac

---

<sup>286</sup> Crookes, “Genesis,” 50.

<sup>287</sup> Crookes, “Genesis,” 55.

<sup>288</sup> Crookes, “Genesis,” 52.

<sup>289</sup> Crookes, “Genesis,” 54.

outlined Crookes's theory and then critiqued it.<sup>290</sup> "As to the details of his [Crookes's] theory," he concluded, "I have not means of disputing them, since they all rest on hypotheses whose experimental demonstration is, and for a long time will be, impossible."<sup>291</sup>

Marignac was prominent in the field of rare earths research and his opinions held weight, particularly with chemists on the continent. Crookes therefore felt compelled to respond to Marignac's critiques. In an unsigned piece in the *Chemical News*, Crookes wrote, "I certainly should not have ventured to criticise any remarks he might make on my own researches had he not admitted in this paper that he may have imperfectly understood my arguments owing to want of familiarity with the English language."<sup>292</sup> He then proceeded to illustrate where Marignac had misunderstood his argument. However, it is doubtful that Crookes's explanations did anything to change Marignac's opinion.

But whether or not Crookes's theory of the genesis of the elements was universally popular, the idea of the unity of matter was in the air again. Several other theories also made their appearance in the 1880s and 1890s. Examples of theories which included an aspect of genesis or evolution as well as unity include

---

<sup>290</sup> C. Marignac, "Quelques Réflexions Sur le Groupe des Terres Rares a Propos de la Théorie de M. Crookes sur la Genèse des Éléments," *Archives des Sciences Physiques et Naturelles* 17 (1887): 373-389,

<https://hdl.handle.net/2027/njp.32101033964477?urlappend=%3Bseq=381>.

<sup>291</sup> Robert K. DeKosky, "Spectroscopy and the Elements in the Late Nineteenth Century: The Work of Sir William Crookes," *The British Journal for the History of Science* 6 (1973): 417, <http://www.jstor.org/stable/4025503>. French original, Marignac, "Quelques," 375-376; "Quant aux détails de sa théorie...".

<sup>292</sup> [William Crookes], "Notes on the Group of Rare Earths, Considered a Propos of Mr. Crookes's Theory of the Genesis of the Elements," *Chemical News* 56 (1887): 39, <https://hdl.handle.net/2027/njp.32101075379337?urlappend=%3Bseq=51>.

Gustav Wendt's biogenic foundation for chemistry and physics,<sup>293</sup> William Preyer's genetic system of the elements,<sup>294</sup> Eduard Meusel's unity of the elements,<sup>295</sup> and Hinrichs's revised version of the unity of matter.<sup>296</sup> All of these scientists published monographs on their theories, reviews of which appeared in multiple chemical and scientific journals.

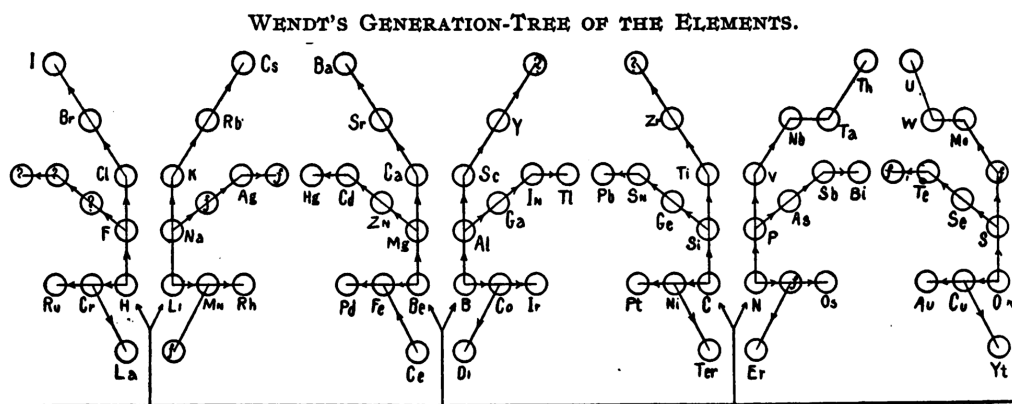

**Figure 3.10: Wendt's Family Tree of the Elements (1891)**

Crookes and many of those who espoused theories of the unity of matter used the periodic system as evidence of and a buttress for their theories. Many also created visual representations of the evolution of the elements that quite often resembled representations of the periodic law, some more novel than others.

Wendt's evolutionary scheme was represented by a family tree of the elements (Fig.

<sup>293</sup> Gustav Wendt, *Die Entwicklung der Elemente. Entwurf zu einer biogenetischen Grundlage für Chemie und Physik* (Berlin: Hirschwald, 1891), <https://books.google.com/books?id=ZKQtAQAAMAAJ>.

<sup>294</sup> W. Preyer, *Die Organischen Elemente und ihre Stellung im System* (Weisbaden: J. F. Bergmann, 1891), <https://books.google.com/books?id=QYBZAAAAYAAJ>.

<sup>295</sup> Eduard Meusel, *Der Monismus der chemischen Elemente* (Liegnitz: Ewald Scholz, 1893), <https://books.google.com/books?id=uDNDAAAAIAAJ>.

<sup>296</sup> Gustavus Detlef Hinrichs, *The True Atomic Weights of the Chemical Elements and the Unity of Matter* (St. Louis: Carl Gustav Hinrichs, 1894), <https://books.google.com/books?id=8XAMAQAIAAJ>.

10). The tree comprised seven stem elements from which groups of elements branch off, each of which is composed of a set of elements that can be found grouped together on Mendeleev's table.<sup>297</sup> The British chemist Henry Wilde developed a theory of the evolution of the elements based on the relative distances of the planets from the sun. He was critical of Mendeleev's periodic law and Newlands' law of the octaves as they presented "numerous discrepancies."<sup>298</sup> Despite this, the visual representation of his evolutionary theory, based upon the relative distances of the planets from the sun, was a tabular form that bore close resemblance to those of Newlands and Mendeleev (Fig. 11).<sup>299</sup>

*Table of Elementary Substances,  
arranged with their Atomic Weights in Multiple Proportions, 1878.*

1	+ H <sup>n</sup> -	+ H <sup>2n</sup> -	H <sup>3n</sup>	H <sup>4n</sup>	H <sup>5n</sup>	H <sup>6n</sup>	H <sup>7n</sup>		
2	Li = 7 0.691 7 <sup>a</sup>	GI = 8 1.641 1.31	C = 12 1.713	--=16	B = 10 1.18 2.63	--=18	N = 14 1.14		
3	Na=23 0.98	F = 19 1.9	Mg=24 1.74	O = 16 1.6	Al = 27 2.95	--=32	P = 30 2.1 1.83	Si = 35 2.49	
4	K = 39 0.86	Cl = 35 1.5	Ca = 40 1.58	S = 32 2.06	Sc = 42 3.4	Ti = 48 4.11	V = 50 3.5 5.12	Cr = 54 3.8 6.84	Fe = 56 4.5 6.8-8.141
5	Cu = 62 0.93	Zn = 64 0.95	Ce = 60 0.84	Ge = 72 0.83	As = 75 0.83				Mn = 56 4.5 6.8-8.66
6	Rb = 85 1.32	Br = 81 3.0	Sr = 88 2.4	Se = 80 4.8	Ga = 96 6.95	Zr = 92 4.151 5.41	Nb = 95 6.97	Mo = 96 8.6	Ni = 56 6.8-8.66
7	Ag = 108 10.6	Cd = 112 8.95	Y = 123 8.11	Sn = 116 8.11	Sb = 120 7.29				Co = 56 6.8-8.96
8	Cs = 131 1.88	I = 127 4.98	Ba = 136 3.75	Te = 128 6.3	In = 150 7.6 11.54	La = 140 6.7	x = 140 8.16	x = 144 10.0	Pd = 105 10.52-12.0
9	x = 154 12.2	x = 160 10.13		Er = 177 9.41	x = 164 11.706	x = 165 9.11	x = 165 8.301		Rh = 105 10.44-11.2
10	x = 177 2.2	x = 184 4.8		Tl = 204 11.86	D = 186 8.01	Ta = 185 10.781 9.81	W = 186 18.26		Ru = 105 10.44-11.4
11	Hg = 200 13.6	Pb = 208 11.44		Th = 231 11.23	U = 240 18.4	Bi = 210 9.83			Au = 190 19.7 -21.60

\* Accepted atomic weights. † Estimated. ‡ Anthracite. § Electro-deposited.  
+ Specific gravities.

\*\* The accepted atomic weights are taken from the standard works and tables of WURST, ROSCOE and SCHORLEMMER, J. P. COOKE, F. W. CLARKE, and WATTS' Dic. Chem. Suppl., p. 247—Atomicity.

**Figure 3.11: Wilde's Table of Elementary Substances (1892)**

<sup>297</sup> Wendt, *Die Entwicklung*. The family tree can be found in a fold-out at the end of the volume; another drawing of it can be found in Venable, *Development*, 245.

<sup>298</sup> Henry Wilde, *On the Origin of Elementary Substances, and on Some New Relations of Their Atomic Weights* (London: Kegan Paul, Trench, Trübner & Co., 1892), vi, <https://books.google.com/books?id=1fRaAAAQAAJ>. The volume was published in English with a French translation, as well as in English with a German translation.

<sup>299</sup> Wilde, *On the Origin*, plate at end of the volume.

Mendeleev was not sympathetic to the periodic law being affiliated with ideas regarding the unity of matter. In his 1889 Faraday Lecture, given before the Chemical Society in London, Mendeleev traced the history and origins, as well as the development, of the periodic law.<sup>300</sup> He quite firmly divorced it from any notions of the evolution of the elements or the unity of matter, as the law was based “on the solid and wholesome ground of experimental research.”<sup>301</sup> The unity of matter, on the other hand, was a “relic of the torments of classical thought,” a remnant of an ancient time when our ancestors had no choice but to concoct a hypothesis to explain the universe.<sup>302</sup> As for theories regarding the compound character of the elements, Mendeleev declared they “must be classed amongst mere utopias.”<sup>303</sup> Despite the severity of Mendeleev’s words, theories of the unity of matter and of the compound nature of the elements continued to flourish in the last decades of the nineteenth century and to inspire new visual representations of the periodic system.

### **Visual Representations of the Periodic Law**

As much as Mendeleev had vilified theories regarding the unity of matter and the compound nature of the elements, he also decried many of the graphical representations that accompanied them. In his Faraday Lecture, he objected to the use of non-tabular forms: “neither the trigonometric functions proposed by

---

<sup>300</sup> Mendeleeff, “The Periodic Law of the Chemical Elements,” *Journal of the Chemical Society. Transactions* 55 (1889): 634-656, doi:10.1039/CT8895500634; hereafter cited as Mendeleeff, “Faraday Lecture.”

<sup>301</sup> Mendeleeff, “Faraday Lecture,” 644.

<sup>302</sup> Mendeleeff, “Faraday Lecture,” 644-645.

<sup>303</sup> Mendeleeff, “Faraday Lecture,” 647.



Ridberg<sup>304</sup> [*sic*] and Flavitzky,<sup>305</sup> nor the pendulum-oscillations suggested by Crookes,<sup>306</sup> nor the cubical curves of the Rev. Mr. Haughton,<sup>307</sup> which have been proposed for expressing the periodic law ... can represent the periods of the chemical elements.”<sup>308</sup> This was the major point of contention for Mendeleev, that the periods each contain a finite number of elements, not an infinite number. In other words, the periods are distinct and do not correspond to continuous evolution.

Mendeleev was not completely against curved forms of the periodic table. He felt the periodic law could be expressed well in spiral forms “where each turn will express a definite period” as well as screw-like forms “where each turn of the screw will represent a period,”<sup>309</sup> unlike the above-mentioned curves in which periods were not definitively defined. Nevertheless, Mendeleev did not draw a spiral form he considered to be satisfactory.<sup>310</sup> Instead, most of the tables he drew were

---

<sup>304</sup> J. R. Rydberg, “Om de Kemiska Grundämnenas Periodiska System,” *Bihang till Kongl. Svenska vetenskaps-akademiens handlingar* 10:2 (1885): 1-31, <https://hdl.handle.net/2027/hvd.32044106419278?urlappend=%3Bseq=75>.

<sup>305</sup> Flavian Flavitzky, *A Function Expressing the Periodicity of the Chemical Elements* (Kazan, 1887). I have not been able to locate this publication; an abstract and illustration of Flavitzky’s diagram are in Venable, *Periodic Law*, 210-213. This paper was apparently difficult to obtain even in the 1890s. Venable wrote to Mendeleev asking for assistance in obtaining a copy of the paper; see George B. Kauffman, “The Reception of Mendeleev’s Ideas in the United States and Mendeleev’s Correspondence with American Scientists,” *Archives Internationales d’Histoire des Sciences* 23 (1970): 102.

<sup>306</sup> Crookes, “Genesis,” 52.

<sup>307</sup> Samuel Haughton, “Geometrical Illustrations of Newlands’ and Mendelejeff’s Periodic Law of the Atomic Weights of the Chemical Elements,” *Transactions of the Royal Irish Academy* 29 (1887-1892): 207-246, <http://www.jstor.org/stable/30078815>.

<sup>308</sup> Mendeleeff, “Faraday Lecture,” 641.

<sup>309</sup> Smith, “Persistence,” 293.

<sup>310</sup> Smith, “Persistence,” 292.

tabular. However, he had trouble finding a satisfactory version of a table in this form, as well. The original version he published in 1869 was a vertical, long form table. Aside from this one, all of the tabular forms he drew until his death in 1907 were horizontal ones. In the first years after his discovery of the periodic system, Mendeleev appeared to prefer short form tables, although his preference changed to the long form by 1880.<sup>311</sup>

Over his lifetime, Mendeleev drew more than 60 tables, not finding any of them satisfactory.<sup>312</sup> In part, this was because he felt there was a connection between “a precise functional representation of the periodic law” and an “explanation of the cause of this law.”<sup>313</sup> In an 1898 article, Mendeleev noted that many scientists – most notably Rydberg, Bazarov,<sup>314</sup> Haughton, Chicherin,<sup>315</sup> Flavitsky, and Mills<sup>316</sup> – had “tried, from various sides, to find a precise expression of the periodic law, but this subject has so far not been amenable to precise and general deductions.” Mendeleev then discussed what he referred to as a “frequently overlooked fact,” that being “that an ordinary ‘continuous’ function, e.g. a sine function, may not serve as an expression of the periodic law, because the elements

---

<sup>311</sup> Smith, “Persistence,” 288-289.

<sup>312</sup> See Smith, “Persistence,” chapter IV for a brief discussion of the types of tables Mendeleev drew and for depictions of 65 of them.

<sup>313</sup> Smith, “Persistence,” 298.

<sup>314</sup> A. Bazarov, “Ob atomnykh vesakh elementov,” *Zhurnal Russkogo Khimicheskogo Obshchestva* 19 (1887): 61-73, [https://hdl.handle.net/2027/uc1.\\$b625247?urlappend=%3Bseq=203](https://hdl.handle.net/2027/uc1.$b625247?urlappend=%3Bseq=203). English translation of article title comes from Venable, *Development*, 299.

<sup>315</sup> B. N. Chicherin, *Sistema khimicheskikh elementov* (Petersburg: P. I., 1888).

<sup>316</sup> Edmund J. Mills, “On Melting-point and Boiling-point as Related to Chemical Composition,” *Philosophical Magazine*, 5<sup>th</sup> ser., 17 (1884): 173-187, <https://hdl.handle.net/2027/wu.89048311823?urlappend=%3Bseq=185>.

are characterised above all by ‘breaks.’”<sup>317</sup> This reiterated a point he had made in his Faraday Lecture almost a decade earlier. For Mendeleev, it was the periodic nature of the law that was vitally important.

Although Mendeleev was insistent that graphical representations of the periodic law must show distinct periods, others were less so. Edward H. Rennie, in his 1890 Presidential Address before the chemistry and mineralogy section of the Australasian Association for the Advancement of Science, argued that Mendeleev had missed the point in his Faraday Lecture. “[T]he real object of these so-called curves,” he said, “are not intended to be understood in a purely mathematical sense, but simply as graphic representations of the periodic law, which enable us to see more clearly its prominent features.”<sup>318</sup> For Rennie, and for many chemists, the graphic representations were attempts to better understand the periodic law through visual means, rather than as a way to search for the underlying essence of the law.

One of the earliest non-tabular forms to be published was that of the Swiss chemist Heinrich Baumhauer. In his 1870 monograph, Baumhauer discussed the then-recent work of Mendeleev and Lothar Meyer.<sup>319</sup> However, he went on to suggest a graphic representation of the periodic law in the form of a spiral (Fig. 12). “A clear view of the elements,” he wrote, could be obtained by arranging them in

---

<sup>317</sup> Quoted in Smith, “Persistence,” 298.

<sup>318</sup> E. H. Rennie, “Chemistry and Mineralogy,” *Chemical News* 62 (1890): 54, <https://hdl.handle.net/2027/inu.30000088771088?urlappend=%3Bseq=377>.

<sup>319</sup> Heinr. Baumhauer, *Die Beziehungen Zwischen dem Atomgewichte und der Natur der Chemischen Elemente* (Braunschweig: Friedrich Vieweg und Sohn, 1870), [https://books.google.com/books?id=yQw\\_AAAAYAAJ](https://books.google.com/books?id=yQw_AAAAYAAJ). Note: the two vertical lines are a result folds in the paper of the original and are not a part of the spiral.

order of increasing weight in the form of a spiral, with hydrogen in the center.

Baumhauer also stated the idea that there are one or a few primal elements could be “expressed in the table in the reduction of the complicated elements to certain types.” He did caution that this was “of course only speculation.”<sup>320</sup>

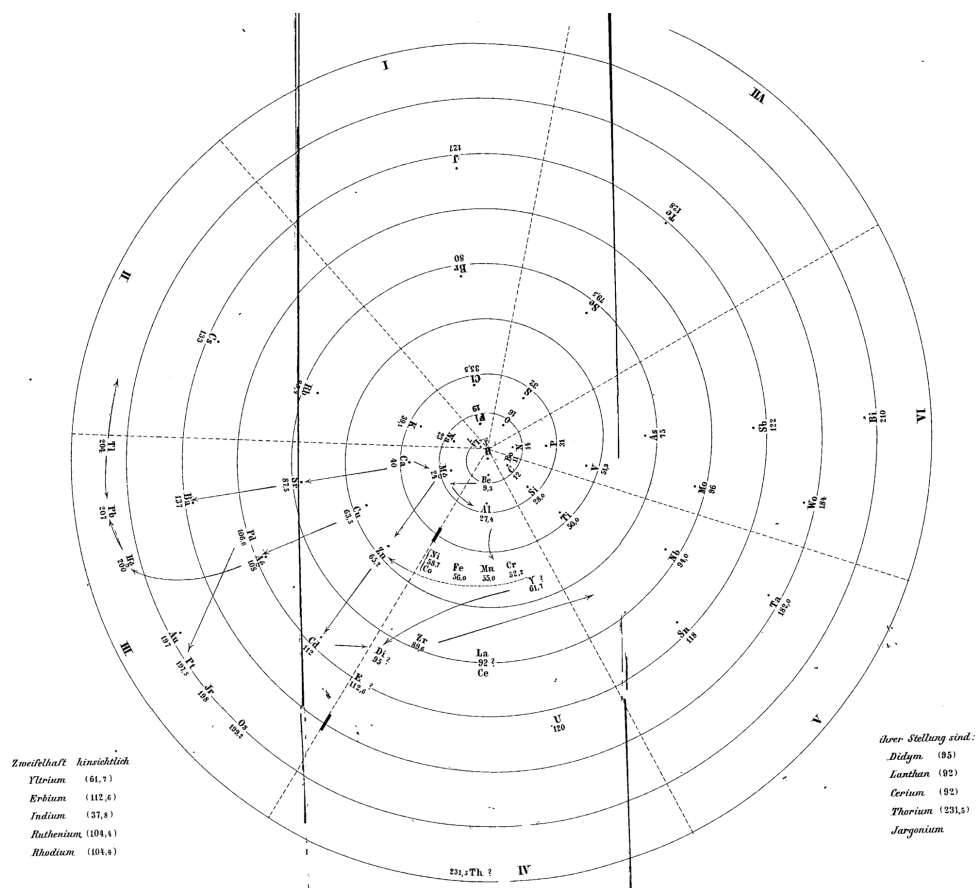

**Figure 3.12: Baumhauer’s Spiral (1870)**

There was an explosion of graphical representations of the periodic law in the 1880s and 1890s.<sup>321</sup> The iconic rocket ship form that is generally referred to as the Thomsen-Bohr table had an earlier version, a table published by Thomas Bayley

<sup>320</sup> English quotes from Venable, *Periodic Table*, 120, 123.

<sup>321</sup> For a wider array of graphical representations created during the 1880s and 1890s, see Venable, *Periodic Table*.

in 1882 (Fig. 13).<sup>322</sup> Bayley stated this table was “similar to, but not identical with, Mendelejeff’s classification” and that it represented the “systematic grouping [of elements] into families.”<sup>323</sup> Bayley also created a curve (Fig. 14) very similar to Lothar Meyer’s atomic volume curve (see Fig. 5).<sup>324</sup> Bayley was engaged in research to determine which chemical and physical properties of the elements – other than atomic weight and atomic volume – conformed to the periodic law, and this form was very popular amongst others engaged in similar research.

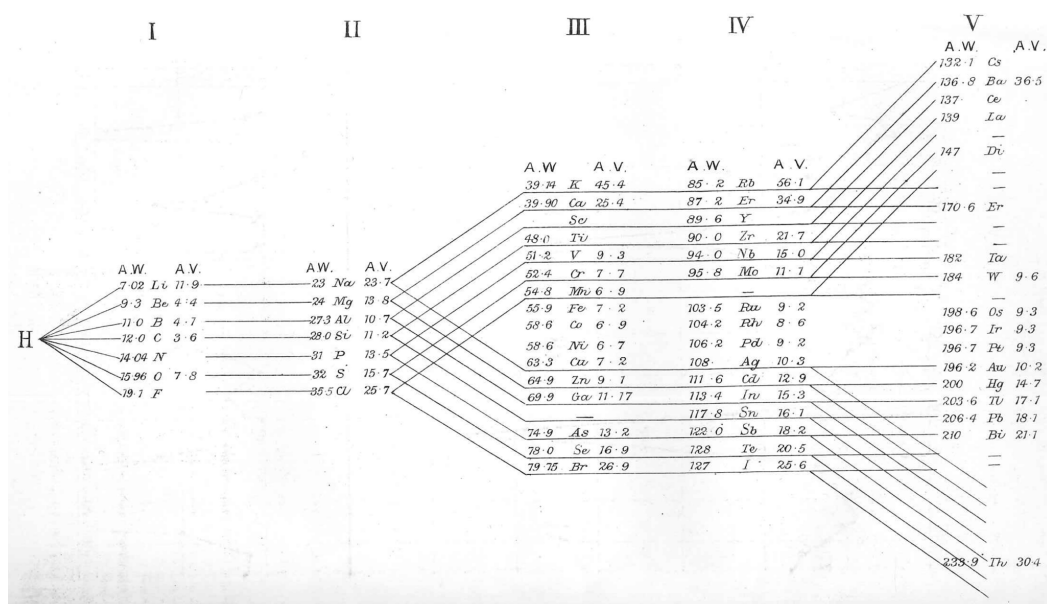
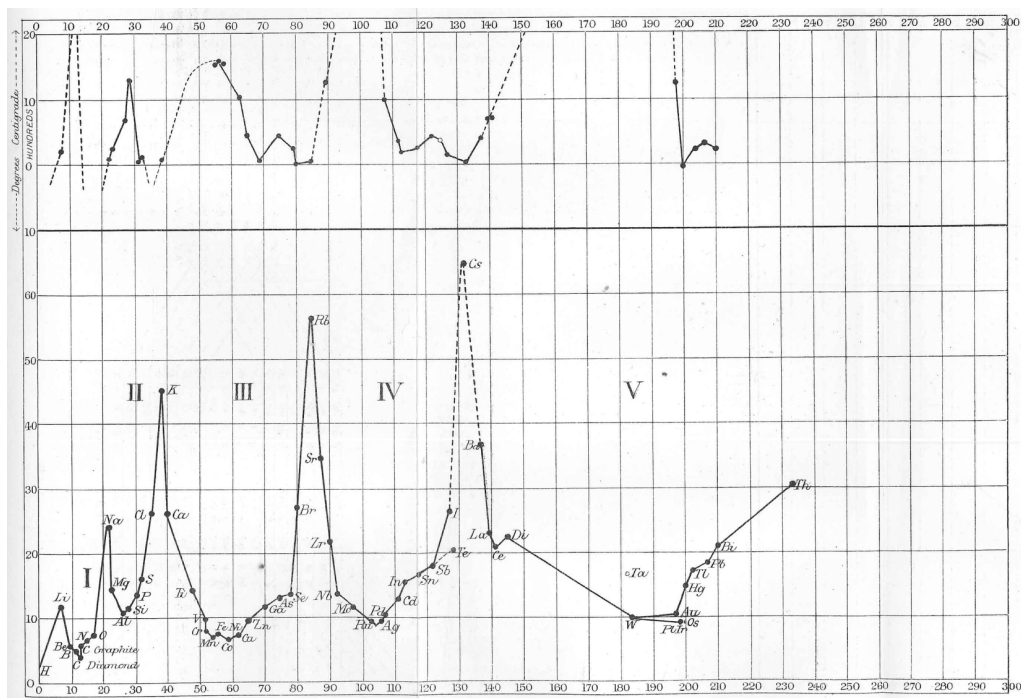

Figure 3.13: Bayley’s Table (1892)

<sup>322</sup> Thomas Bayley, “On the Connexion Between the Atomic Weight and the Chemical and Physical Properties of Elements,” *Philosophical Magazine*, 5<sup>th</sup> ser., 13 (1882): 26-37, <https://hdl.handle.net/2027/hvd.32044036926350?urlappend=%3Bseq=42>. The table is Fig. 1 of Plate II.

<sup>323</sup> Bayley, “Connexion,” 29.

<sup>324</sup> Bayley, “Connexion,” 32; curve is Fig. 2 of Plate II.



**Figure 3.14: Bayley's Curve (1892)**

In 1895, the Danish chemist Julius Thomsen published a graphical representation of the periodic law that bore a distinct resemblance to that of Bayley, however he seemed not to have been aware of Bayley's table.<sup>325</sup> Thomsen's representation was more compressed than Bayley's, however it also had a rocket shape (Fig. 15). Thomsen felt his arrangement was more "satisfactory," particularly for the placement of the rare earths, than most tabular arrangements. It was an arrangement he had "used," though it is unclear what he meant by that (research, teaching, something else?). He concluded: "Although the table here given differs from the customary tables only in its arrangement, I believe that it presents in a

<sup>325</sup> Julius Thomsen, "Systematische Gruppierung der chemischen Elemente," *Zeitschrift für Anorganische Chemie* 9 (1895): 190-193, <https://hdl.handle.net/2027/uc1.b3959055?urlappend=%3Bseq=200>. The resemblance was pointed out by Venable in a letter to the editor; see "New Grouping of the Elements," *Chemical News* 72 (1895): 126, <https://hdl.handle.net/2027/inu.30000088771047?urlappend=%3Bseq=464>.

very perspicuous manner the facts which may be deduced from the periodic system.”<sup>326</sup> Twenty years later, Niels Bohr would declare Thomsen's table to be “more suited for comparison with theories of atomic constitution.”<sup>327</sup>

**Systematische Gruppierung der chemischen Elemente.**

		Cs 133
		Ba 137
		La 138
		Ce 140
		Ne 141
		Pr 144
		— —
		Sm 150
		— —
		Gd 156
		Trb 160
		— —
		Er 166
		— —
		Thu 171
		Yb 173
		— —
		— —
		Ta 183
		W 184
		— —
		Os 191
		Ir 193
		Pt 195
		Au 197
		Hg 200
		Tl 204
		Pb 207
		Bi 209
		— —
		— —

Elektropositive Elemente.		
	K 39.85 Rb	
	Ca 40.87 Sr	
	Sc 44.89 Y	
	Ti 48.91 Zr	
	V 51.94 Nb	
	Cr 52.96 Mo	
	Mn 55. — —	
	Fe 56.102 Ru	
	Co 59.103 Rh	
	Ni 59.107 Pd	
	Cu 63.108 Ag	
	Zn 65.112 Cd	
	Ga 69.114 In	
	Gr 72.119 Sn	
	As 75.120 Sb	
	Se 79.125 Te	
	Br 80.127 J	
Elektronegative Elemente.		

H 1	{	Li 7.23 Na	}
	{	Be 9.24 Mg	}
	{	B 11.27 Al	}
	{	C 12.28 Si	}
	{	N 14.31 P	}
	{	O 16.32 S	}
	{	F 19.35 Cl	}

**Figure 3.15: Thomsen's Table (1895)**

Many other non-tabular forms of the periodic system were also created. In 1888, the Irish mathematical physicist G. Johnstone Stoney read a paper before the Royal Society in which he presented a logarithmic spiral of the atomic spheres.

<sup>326</sup> Julius Thomsen, “Systematic Arrangement of the Chemical Elements,” *Chemical News* 72 (1895): 90, 91,

<https://hdl.handle.net/2027/inu.30000088771047?urlappend=%3Bseq=427>.

<sup>327</sup> Niels Bohr, *The Theory of Spectra and Atomic Constitution* (Cambridge: Cambridge University Press, 1922): 70.

Stoney maintained that this curve was “of singular convenience for laboratory use.” The spiral, he stated, “presents conspicuously the information which a Newlands and Mendelejeff’s table is capable of supplying, with the further advantage of also placing before the eye an intelligible representation of the atomic weights.”<sup>328</sup> The full paper was never published and a copy of the spiral did not appear in print until 1902 (Fig. 16).<sup>329</sup>

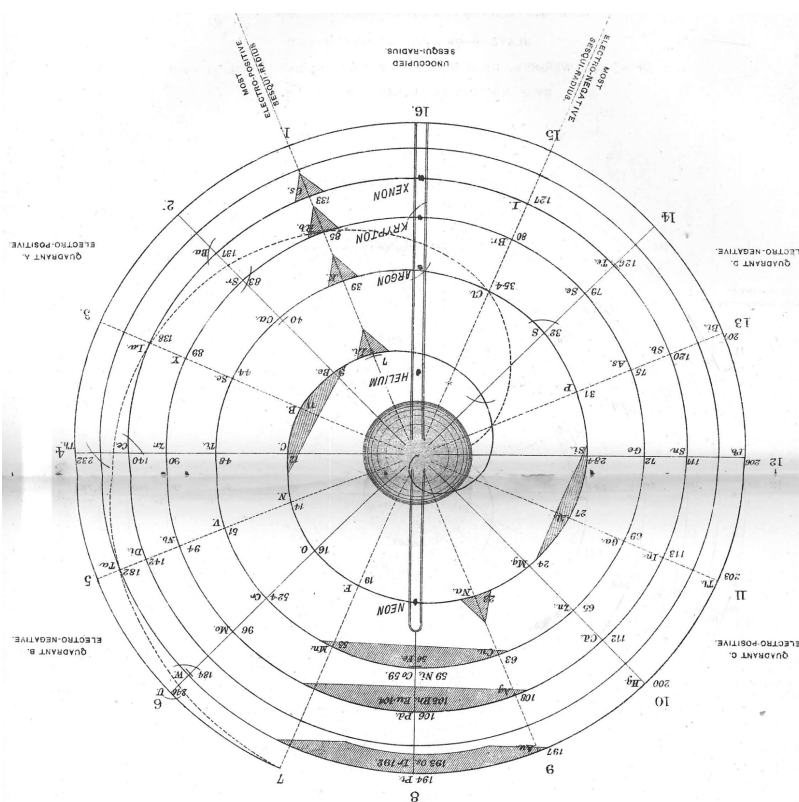

**Figure 3.16: Stoney’s Spiral (updated 1902 version)**

<sup>328</sup> G. Johnstone Stoney, “On the Logarithmic Law of Atomic Weights,” *Proceedings of the Royal Society of London* 44 (1888): 117, <http://www.jstor.org/stable/114700>.

<sup>329</sup> An “updated” version of the spiral can be found in G. Johnstone Stoney, “On the Law of Atomic Weights,” *Philosophical Magazine*, 6<sup>th</sup> ser., 4 (1902): 411-416, <https://hdl.handle.net/2027/hvd.32044089572200?urlappend=%3Bseq=441>; table on Plate IV. Excerpts from the full 1888 paper as well as the original version of the spiral can be found in Lord Rayleigh, “On Dr. Johnstone Stoney’s Logarithmic Law of Atomic Weights,” *Proceedings of the Royal Society of London* 85A (1911): 471-473, <http://www.jstor.org/stable/93280>.



There were, of course, those who felt tabular forms were better for visually representing the periodic law. In 1891, James Walker published a short paper in the *Chemical News* advocating for Mendeleev's table.<sup>330</sup> He argued that it was “the best tabular expression” as it illustrated the distinct periods. “Lothar Meyer’s spiral and the tables based on it do not show the same relations of the elements amongst themselves to the same advantage,” he declared. Rather, these alternate forms served to separate elements with analogous properties into groups that reduced the ability to make general statements about the odd series and the even series of elements. On a curved form, there are no clear breaks between periods whereas on tabular form “the various periods are brought alongside each other” and “become neighbours.”<sup>331</sup> This argument bears some relation to Mendeleev’s objections to curved forms.

Tabular forms that did not look like Mendeleev’s tables were also created. The English chemist Henry Bassett created a stacked tabular form in 1892 (Fig. 17).<sup>332</sup> He presented it as “a more comprehensive and satisfactory expression” of the periodic law than Mendeleev’s table.<sup>333</sup> The table was meant to be rolled around a cylinder, with a circumference equaling ten of the vertical spaces, to “produce a series of derived tables of considerable interest.” Each turn of the cylinder revealed

---

<sup>330</sup> James Walker, “On the Periodic Tabulation of the Elements,” *Chemical News* 63 (1891): 251-253,

<https://hdl.handle.net/2027/nyp.33433062748128?urlappend=%3Bseq=257>.

<sup>331</sup> Walker, “Tabulation,” 251-252.

<sup>332</sup> Henry Bassett, “A Tabular Expression of the Periodic Relations of the Elements,” *Chemical News* 65 (1892): 3-4, 19,

<https://hdl.handle.net/2027/nnc1.cu09484205?urlappend=%3Bseq=11>.

<sup>333</sup> Bassett, “Tabular,” 3.

a table containing a group of elements. Bassett noted that his table provided “rational positions for many, or possibly all” of the rare earth elements, which he described as “these perplexing elements.”<sup>334</sup>

			Cs 133	226?	
			Ba 137	?	
			La 138.2	?	
			Ce 140.2	Th 232.6	
			Ndy 140.8	?	
			Pdy 143.6	U 239.6	
			148?	241?	
			Sm 150	?	
			?	?	
			?	?	
			154?	248?	
			?	?	
			Tb 159.5	?	
			Ho 162	?	
			?	?	
			Er 166.3	?	
			169?	263?	
			Tm 170.4	?	
			?	?	
			Yb 173	?	
			K 39.1	Rb 85.5	174?
			Ca 40	Sr 87.6	?
			Sc 44	Y 89.1	?
			Ti 48	Zr 90.6	?
			V 51.4	Nb 94	Ta 182.6
			Cr 52.1	Mo 96	W 184
			Mn 55	100?	189?
			Fe 56	Ru 101.6	Os 191.7
			Ni 58.7	Rh 103.5	Ir 193.1
			Co 59	Pd 106.6	Pt 195
Li 7	Na 23	Cu 63.4	Ag 107.9	Au 197.3	
Be 9	Mg 24.3	Zn 65.3	Cd 112	Hg 200	
B 11	Al 27	Ga 69	In 113.7	Tl 204.2	
C 12	Si 28.4	Ge 72.3	Sn 119	Pb 207	
N 14	P 31	As 75	Sb 120	Bi 208.9	
O 16	S 32.1	Se 79	Te 125	?	
F 19	Cl 35.5	Br 80	I 126.9	216?	

**Figure 3.17: Bassett’s Table (1892)**

A long tabular form, at first glance similar to the standard table we are familiar with today, was published in 1893 by P. J. F. Rang (Fig. 18). In this table, the elements were arranged “in their respective series, so that all the allied elements should come in the same vertical row.”<sup>335</sup> Rang published an updated version of this table in 1895 (Fig. 19), including some elements “that have not been introduced

<sup>334</sup> Bassett, “Tabular,” 4.

<sup>335</sup> P. J. F. Rang, “The Periodic Arrangement of the Elements,” *Chemical News* 67 (1893): 178, <https://hdl.handle.net/2027/inu.30000088771062?urlappend=%3Bseq=186>.

before in any period-table, and are therefore unknown to many.”<sup>336</sup> Rang ended by claiming his table “has place for all elements, and fulfils every proper requirement of to-day” and that it “is the truest and best tabular arrangement of the elements yet produced.”<sup>337</sup> Similar claims were made by many of the chemists who created their own graphical representations of the periodic system. Although acceptance of the periodic law grew, there was not yet consensus on its graphical representation.

Valence.	I.	II.	III.	IV.	V.	VI.	VII.	VIII.	I.	II.	III.	IV.	V.	VI.	VII.	
Series.	..	..	..	..	..	..	..	..	..	..	..	..	..	..	..	
1.	Li	Be	B	C	..	..	..	..	..	..	..	..	..	..	..	
2.	Na	Mg	Al	Si	..	..	..	..	..	..	..	..	..	N	O	
3.	K	Ca	Sc	Ti	V	Cr	Mn	Fe	Ni	Co	Cu	Zn	Ga	Ge	As	
4.	Rb	Sr	Y	Zr	Nb	Mo	..	Ru	Rh	Pd	Ag	Cd	Tl	Sn	Sb	
5.	Cs	Ba	Di	..	Ta	W	..	Os	Tr	Pt	Au	Hg	..	Pb	Bi	
6.	..	Ms	..	Th	..	U	..	..	..	..	..	..	..	..	..	
7.	..	..	..	..	..	..	..	..	..	..	..	..	..	..	..	
Group I.	2.	3.					4.					5.			6.	7.
A.			B.				C.				D.					

Figure 3.18: Rang’s 1893 Table

Valence.	I.	II.	III.	IV.	V.	VI.	VII.	VIII.	I.	II.	III.	IV.	V.	VI.	VII.	VIII.
Series.	..	..	..	..	..	..	..	..	..	..	..	..	..	..	..	..
1.	Li	Be	B	C	..	..	..	..	..	..	..	..	..	..	..	..
2.	Na	Mg	Al	Si	..	..	..	..	..	..	..	..	..	..	..	..
3.	K	Ca	Sc	Ti	V	Cr	Mn	Fe	Ni	Co	Cu	Zn	Ga	Ge	As	Se
4.	Rb	Sr	Y	Zr	Nb	Mo	..	Ru	Rh	Pd	Ag	Cd	In	Sn	Sb	Te
5.	Cs	Ba	La	Yb	Ta	W	Ur	Os	Ir	Pt	Au	Hg	Tl	Pb	Bi	Ast
6.	(+)	Ms	(+)	Th	Np	U	(?)	(?)	(?)	(?)	..	..	..	..	..	..
7.	..	..	..	..	..	..	..	..	..	..	..	..	..	..	..	..
$\text{III.}\alpha = \text{Sc, Pp.}$ $\text{I.b} = \text{Cu, Ng.}$ $\text{III.}\alpha \text{ and IV.}\alpha = \text{La, Ce, Ny, Py, Sm, Gd, Tb, Ho, Er, Tm, Dc, Yb. . .}$ * Unnamed element accompanying helium.																

Figure 3.19: Rang’s 1895 Table

### Pedagogy and the Periodic System

Few of those who published their representations mentioned why they had created them. However, the periodic system had begun to make its way into the

<sup>336</sup> F. Rang, “The Period-Table,” *Chemical News* 72 (1895): 201, <https://hdl.handle.net/2027/inu.30000088771047?urlappend=%3Bseq=538>. Rang included a “Table of Half-Forgotten Elements” to provide their atomic weights as well as references in the *Chemical News* in which more information could be found. Many of these elements were not considered to be so by the majority of the chemical community.

<sup>337</sup> Rang, “The Period-Table,” 201.

lecture hall, as well as the laboratory, becoming integrated into chemical education. Although Bassett did not state how the table he created was used, the same general type – a printed table made to be cut out and glued onto a cylinder to form a three-dimensional table – became a popular pedagogical tool in the last decades of the nineteenth century. James H. Shepard, who wrote a popular series of textbooks, included such a table as early as 1886 (Fig. 20).<sup>338</sup>

I.	II.	III.	IV.	V.	VI.	VII.	VIII.
R <sub>2</sub> O	RO	R <sub>2</sub> O <sub>3</sub>	RO <sub>2</sub> RH <sub>4</sub>	R <sub>2</sub> O <sub>5</sub> RH <sub>5</sub>	RO <sub>3</sub> RH <sub>7</sub>	R <sub>2</sub> O <sub>7</sub> RH	
H 1							
Li 7	Be 9	B 11	C 12	N 14	O 16	F 19	
Na 23	Mg 24	Al 27	Si 28	P 31	S 32	Cl 35.5	
K 39	Ca 40	Sc 44	Ti 48	V 51	Cr 52	Mn 55	Fe, Ni, Co 56 58.6 59
Cu 63	Zn 65	Ga 69	— 72(?)	As 75	Se 79	Br 80	
Rb 85	Sr 87	Y 89	Zr 90	Nb 94	Mo 96	— 100(?)	Rh, Ru, Pd 104 104.5 106
Ag 108	Cd 112	In 114	Sn 118	Sb 120	Te 128	I 127	
Cs 133	Ba 137	La 139	Ce 141	Di 144	— 149(?)	— 150(?)	
—	—	—	—	Er 166	— 167(?)	— 169(?)	
—	—	Yb 173	— 178(?)	Ta 182	W 184	— 190(?)	Ir, Os, Pt 192.5 193 194
Au 176	Hg 200	Tl 204	Pb 207	Bi 209	—	—	
—	—	—	Th 232(?)	— 237(?)	U 240		

Note. Cut this chart on this line, and then roll so as to fasten on gummied edge.

Note. Spread gum on this edge.

**Figure 3.20: Shepard's Cylinder Table (1886)**

The representation that Crookes first used to illustrate his hypothesis on the genesis of the elements was, in fact, a modified form of a zigzag curve created by his

<sup>338</sup> James Henry Shepard, *Elements of Inorganic Chemistry, Descriptive and Qualitative* (Boston: D. C. Heath & Co., 1886), 221, <https://books.google.com/books?id=mP44AAAAMAAJ>.

friend J. Emerson Reynolds for use in his lecture hall (Fig. 21).<sup>339</sup> The Irish chemist stated that the visual representation had been “used in my lecture-room for some years in order to illustrate the periodic character of the relation between the atomic weights and properties of the chemical elements.” The curve, he said, “give[s] a special picture of the general relations of the elements.” Although not explicitly stated, it is implied that Mendeleev’s tabular form did not illustrate the relationships between the elements as easily as did Reynolds’s zigzag.<sup>340</sup>

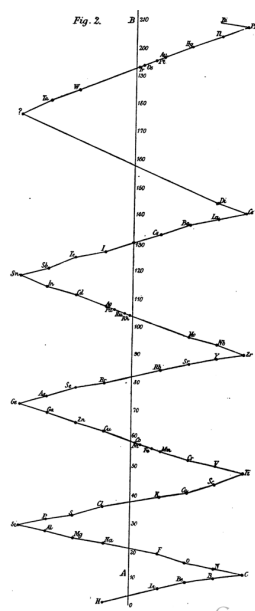

**Figure 3.21: Reynold's Curve (1886)**

Reynolds was not the only professor of chemistry to create his own visual representation of the periodic law for use in the lecture hall. In fact, another chemist laid claim to priority of the graphical form that Reynolds had created. In the

---

<sup>339</sup> Crookes, “Genesis,” 52; table on 53. Crookes, not Reynolds, is the one who referred to this form as a zigzag.

<sup>340</sup> J. Emerson Reynolds, “Note on a Method of Illustrating the Periodic Law,” *Chemical News* 54 (1886): 1, <https://hdl.handle.net/2027/wu.89081861098?urlappend=%3Bseq=19>.

German chemical journal *Berichte*, W. Spring declared that he had “employed this method for six years” in his lectures at the University of Liege (Fig. 22). Spring had also had lithographic cards made for the use of his students. His table “represent[ed] the undulations of the periodic system” and he intended to develop it further.<sup>341</sup> As proof of his priority, Spring submitted copies of the first and second editions of these lithographs to the German Chemical Society.

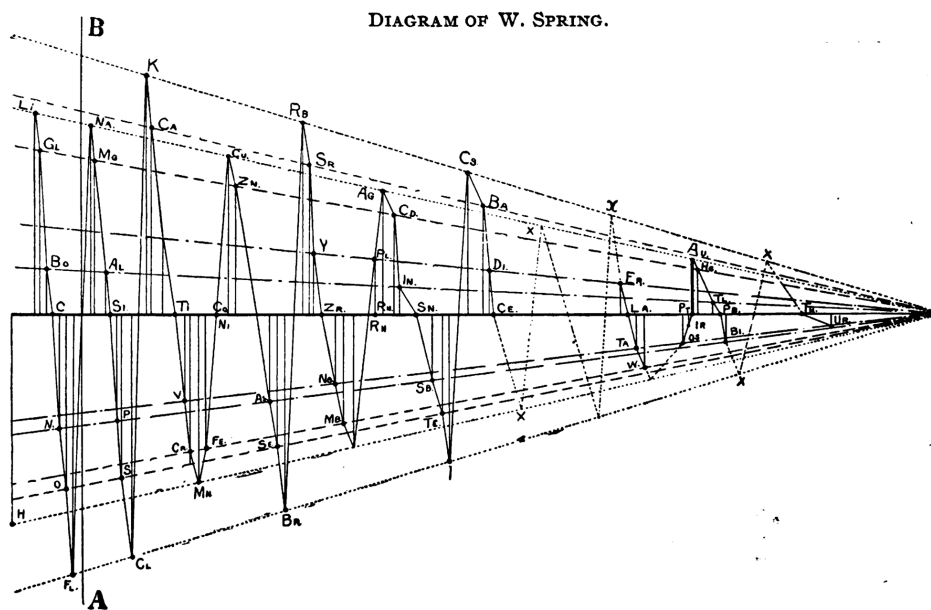

**Figure 3.22: Spring's Curve (1887)**

Several other chemists also produced wall charts of their own graphical arrangements. Hinrichs had a wall chart of his classification scheme “hanging near

<sup>341</sup> W. Spring, “On a Method of Illustrating the Periodic Law,” *Chemical News* 56 (1887): 4, <https://hdl.handle.net/2027/njp.32101075379337?urlappend=%3Bseq=12>. W. Spring, “Ueber eine Methode, das periodische Gesetz zu erläutern,” *Berichte der Deutschen chemischen Gesellschaft zu Berlin* 19 (1886): 3092-3093, <https://gallica.bnf.fr/ark:/12148/bpt6k907075/f574.item>. I have been unable to locate a copy of Spring's table other than the drawing in Venable, *Periodic*, 178.

or over the experiment table” in his lecture hall for at least two decades (Fig. 23).<sup>342</sup>

Lothar Meyer, in a speech on the teaching of inorganic chemistry given to the German Chemical Society in 1893, noted that he had “a chart on the wall of the lecture theatre” which illustrated “the natural system of the elements.”<sup>343</sup>

Mendeleev drew several tables for lectures, one of which he had prepared to hang “on the wall of the large auditorium of the chemistry laboratory building of St. Petersburg University in 1876.”<sup>344</sup>

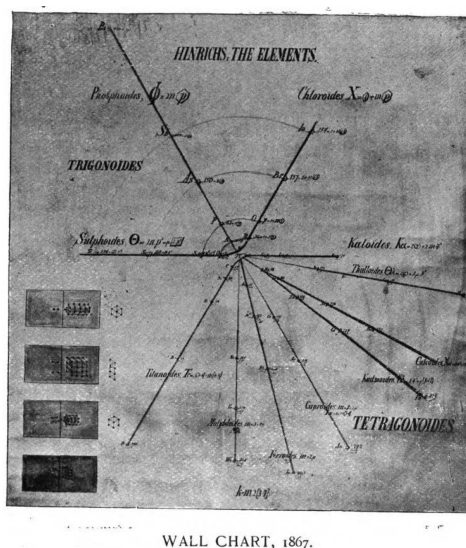

**Figure 3.23: Hinrichs's Spiral (1894)**

<sup>342</sup> Gustavus Detlef Hinrichs, *The True Atomic Weights of the Chemical Elements and the Unity of Matter* (St. Louis: Carl Gustav Hinrichs, 1894), 242, <https://books.google.com/books?id=8XAMAQAIAAJ>. A photograph of this chart is shown in Plate VII, between pages 240 and 241.

<sup>343</sup> Lothar Meyer, “Ueber den vortrag der anorganischen chemie nach dem naturlichen systeme der elemente,” *Berichte der deutschen chemischen Gesellschaft* 26 (1893): 1237, <https://hdl.handle.net/2027/uc1.b3481864?urlappend=%3Bseq=62>. Margaret D. Dougal, “On the Teaching of Inorganic Chemistry,” *Chemical News* 68 (1893): 237, <https://hdl.handle.net/2027/inu.30000088771062?urlappend=%3Bseq=555>. Meyer noted that he also used a periodic table stretched onto a rotating cylinder; “Da die Zuhörer mit dem Begriffe...”.

<sup>344</sup> Smith, “Persistence,” 196; table on 261. According to Smith, the chart was still hanging on the wall of the lecture hall in the 1970s.

Wall charts of periodic tables had begun to be commercially produced and sold as early as the late 1890s. The 1898 price list for chemical apparatus, equipment, preparations, and reagents, published by C. Gerhardt, located in Bonn, Germany, includes chemical charts, presumably for use in the lecture hall. On offer were tables of atomic weights, measuring approximately two feet by three feet, based on the atomic weights determined by Lothar Meyer and Kurt Seubert, as well as tables of atomic weights “arranged according to the natural system of the elements.”<sup>345</sup> Also available were tables of atomic weights arranged according to Mendeleev, showing “the periodic regularity of the elements,” measuring approximately four feet by three feet.<sup>346</sup> In the United States, the Central Scientific Company, headquartered in Chicago, offered a periodic chart of the elements, approximately 3.5 feet by 5 feet. The 1909 catalog described it as being, “The periodic arrangement of the elements according to Mendelejeff, on the basis of O=16,” with atomic weights revised and corrected by Frank W. Clarke.<sup>347</sup> The chart

---

<sup>345</sup> There is no other description, so it is not known for sure what this system was, though it is likely it was a table developed by Lothar Meyer as he referred to his own table with the same phrase.

<sup>346</sup> C. Gerhardt, *Preis-Verzeichniss über Chemische Apparate und Geräthschaften, Chemische Präparate und Reagentien* (Bonn: 1898), 15, <https://archive.org/details/preisverzubechem00gerhrich>.

<sup>347</sup> Central Scientific Company, *Physical and Chemical Apparatus* (Chicago: 1909), 297, <http://www.sil.si.edu/DigitalCollections/trade-literature/scientific-instruments/pdf/sil14-51679.pdf>. There is no drawing of the chart in this catalog, but one can be found in Central Scientific Company, *Laboratory Apparatus for Chemical, Industrial, Bacteriological, Biological, Board of Health and Soil Testing Laboratories* (Chicago: 1918), 144, [https://hdl.handle.net/2027/uc1.\\$c29861](https://hdl.handle.net/2027/uc1.$c29861). Clarke was the sole member of the American Chemical Society’s committee on atomic weights, established in 1893, responsible for compiling and publishing an annual table of atomic weights. As well, he was one of the original members of the International Committee on Atomic Weights, also charged with publishing an annual table of atomic weights.



can be seen hanging on the wall in a photograph of a chemistry lab at the College of Puget Sound, circa 1914.<sup>348</sup>



**Figure 3.24: Chemistry Classroom, University of Colorado at Boulder (1889)**

I have found only a few photographs of chemistry classrooms and lecture halls prior to 1910 in which wall charts of periodic tables can be seen.<sup>349</sup> In the

---

<sup>348</sup> "Chemistry laboratory, circa 1914," *A Sound Past*, Collins Library, University of Puget Sound, <http://digitalcollections.pugetsound.edu/cdm/ref/collection/upsimages/id/2011>. The same wall chart can be found in a photo of a chemistry classroom, circa 1918, at St. Catherine's University in Minnesota; see <http://stkatescheckitout.blogspot.com/2016/02/found-in-archives-chemistry-classroom.html>.

<sup>349</sup> I searched several sites including, Google Images, Flickr, the Library of Congress, and the Digital Public Library of America, using a variety of key words including chemistry class, chemistry classroom, chemistry lecture theatre, and chemistry laboratory, as well as the equivalents in German, French, Italian, Spanish, and Swedish.

photo of the chemistry classroom at the University of Colorado at Boulder in 1889, a short form periodic table is visible on the chalkboard on the side of the room while a long form is displayed on the board at the front (Fig. 24).<sup>350</sup> The use of chalkboards to draw the periodic table speaks to the cost of commercially available wall charts,<sup>351</sup> as well as to the expense of having a large print made for use in a classroom or lecture theatre. A wall chart sits at the front of the chemistry lecture theatre at the University College of North Wales, titled *The Periodic Law* (Fig. 25).<sup>352</sup> On either side of the chalk boards at the front of the chemistry room at Iowa State Normal School sit both a periodic table wall chart as well as a chart which lists the elements, with atomic weights, in alphabetical order (Fig. 26).<sup>353</sup> Such pairings of wall charts were common through much of the twentieth century. For the student new to the periodic system (and even for those familiar with it), locating a specific element in the table solely to find its atomic weight can be challenging; this information is much easier to locate in an alphabetical list of the elements.

---

<sup>350</sup> "Chemistry Class," *Digital Collections*, Denver Public Library, <http://cdm15330.contentdm.oclc.org/cdm/ref/collection/p15330coll22/id/9071>.

<sup>351</sup> In 1909, the Central Scientific Company charged \$1.35 for a periodic table wall chart.

<sup>352</sup> "The Original Lecture Theatre, Bangor," in W. Rogie Angus, "University College of North Wales, Bangor," *Journal of the Royal Institute of Chemistry* 78 (1954): photo between pages 294 and 295.

<sup>353</sup> "Chemistry Classroom in 1908," in "Classrooms from the Late 1800s to the Early 1900s," Rod Library, University of Northern Iowa, <https://library.uni.edu/collections/special-collections/university-archives/classrooms-late-1800s-early-1900s>.



Figure 3.25: Chemistry Lecture Theatre, University College of North Wales



Figure 3.26: Chemistry Room, Iowa State Normal School (1908)

Venable developed a new tabular representation of the periodic law, first published in 1894 (Fig. 27).<sup>354</sup> He wondered why the periodic table was not being made more use of and speculated that it was because of “the imperfections in the arrangements of the elements offered by Mendelejeff and others.”<sup>355</sup> Venable offered this new tabular form, in some respects similar to Mendeleev's short form table, based on his experience teaching chemistry. He advocated the removal of periods; they still “underlie it [the table], but they are out of sight for the present and are not necessary.”<sup>356</sup> Venable stated that he had “found this table very useful in teaching elementary chemistry” at the university level and thought that “it can most profitably be made the basis of the entire course.”<sup>357</sup>

		M H <sub>4</sub>		M H <sub>3</sub>		M H <sub>2</sub>		M H								
M <sub>2</sub> O		M O		M <sub>2</sub> O <sub>3</sub>		M O <sub>2</sub>		M <sub>2</sub> O <sub>4</sub>		M O <sub>3</sub>						
Li	Be	B	C	N	O	F										
Na	Mg	Al	Si	P	S	Cl										
K	Cu	Ca	Zn	Sc	Ga	Ti	Ge	V	As	Cr	Se	Mn	Br	Fe	Co	Ni
Rb	Ag	Sr	Cd	Y	In	Zr	Sn	Nb	Sb	Mo	Te	I	Ru	Rh	Pd	
Cs	Au	Ba	Hg	La	Tl	Ce	Pb	Ta	Bi	W	Os	Ir	Pt			
				Th						Ur						

**Figure 3.27: Venable's Table (1894)**

<sup>354</sup> F. P. Venable, “The Atomic Weights and Their Natural Arrangement,” *Journal of the Elisha Mitchell Scientific Society* 11 (1894): 67-85, <https://hdl.handle.net/2027/inu.30000091968671?urlappend=%3Bseq=77>. A portion of this paper was published as “A Modified Arrangement of the Elements Under the Natural Law,” *Journal of the American Chemical Society* 17 (1895): 75-84, doi:10.1021/ja02157a001.

<sup>355</sup> Venable, “Atomic Weights,” 76.

<sup>356</sup> Venable, “Atomic Weights,” 81.

<sup>357</sup> Venable, “Atomic Weights,” 84.

Extending this thought, Venable co-wrote a chemistry textbook with James Lewis Howe, *Inorganic Chemistry According to the Periodic Law*, in which they made the periodic system the basis of the text. "The complete introduction of this system has not been attempted in any text-book that has come to our notice," they wrote. Most other textbooks, they stated, either made mention of the periodic system but then continued on in the same old fashion or only partially introduced it before falling back onto older systems.<sup>358</sup> Such criticisms were, perhaps, warranted. In a review of Pattison Muir's 1884 *A Treatise on the Principles of Chemistry*, Thomas Carnelley, an early advocate of the periodic system,<sup>359</sup> praised not only the full treatment of the periodic law which appeared in a separate chapter but "[t]he fair and cautious manner in which the author introduces all the ordinarily accepted theories, as well as those which are less known." This cautious manner was, in Carnelley's opinion, "one of the excellent points of the book."<sup>360</sup>

---

<sup>358</sup> F. P. Venable and Jas. Lewis Howe, *Inorganic Chemistry According to the Periodic Law* (Easton, PA: The Chemical Publishing Co., 1898), iii, <https://books.google.com/books?id=OPkJAAAAIAAJ>.

<sup>359</sup> Carnelley was an early and vocal advocate of the periodic system. Mendeleev incorporated his research into the *Principles of Chemistry* from the 4<sup>th</sup> edition onwards and spoke highly of his work on many occasions. At the time of his death at the age of 38, Carnelley was "engaged upon a great work on the chemical and physical constants, in which he was tracing out relations and uniformities not previously detected." See "Professor Thomas Carnelley," *Chemical News* 62 (1890): 126, <https://hdl.handle.net/2027/inu.30000088771088?urlappend=%3Bseq=458>; H. E. R. and P. P. B., "Thomas Carnelley," *Nature* 42 (1890): 522-523, doi:10.1038/042522b0; and Yu. I. Solov'ev, "D. I. Mendeleev and the English Chemists," *Journal of Chemical Education* 61 (1984): 1069-1071, doi:10.1021/ed061p1069.

<sup>360</sup> Thos. Carnelley, "A Treatise on the Principles of Chemistry," *Philosophical Magazine*, 5<sup>th</sup> ser., 19 (1885): 225, [https://hdl.handle.net/2027/uc1.\\$b785891?urlappend=%3Bseq=236](https://hdl.handle.net/2027/uc1.$b785891?urlappend=%3Bseq=236).

Venable and Howe justified their new approach in textbook organization by citing Lothar Meyer's address before the German Chemical Society in 1893. Meyer outlined his approach to the teaching of inorganic chemistry, based upon the periodic system. However, teaching students about the elements in their groups, according to the periodic law, was done before Lothar Meyer's speech and before Venable and Howe's textbook. In an 1893 letter to the editor, W. R. Hodgkinson noted that this was an excellent method and had been "tried with classes of science teachers attending the summer courses at South Kensington as early ... as 1879" with great success.<sup>361</sup> In 1887, Pattison Muir, whose textbook had earlier been praised for cautiousness, advocated for the teaching of the elements in their groups so that a student "gains a basis on which he may rest the superstructure of facts as they are presented to him" and becomes "inspire[d]."<sup>362</sup> Paul Sabatier, unlike most of his French colleagues, had used the periodic law in his teaching prior to 1890, noting that "the students ... accept the presentation of the elements a lot better when thus grouped in a rational and somewhat unexpected manner."<sup>363</sup>

---

<sup>361</sup> W. R. Hodgkinson, "Arrangement of Chemical Lectures," *Chemical News* 68 (1893): 184,

<https://hdl.handle.net/2027/inu.30000088771062?urlappend=%3Bseq=516>.

<sup>362</sup> M. M. Pattison Muir, "On the Teaching of Chemistry," *Nature* 36 (1887): 537, doi:10.1038/036536a0.

<sup>363</sup> Paul Sabatier, "Sur la classification des corps simples par la loi périodique," *Annales de la Faculté des Sciences de Toulouse* 4 (1890): B.3, <https://hdl.handle.net/2027/njp.32101043993706?urlappend=%3Bseq=27>; "Dans mes Leçons à la Faculté...". English translation from Mary Jo Nye, "Nonconformity and Creativity: A Study of Paul Sabatier, Chemical Theory, and the French Scientific Community," *Isis* 68 (1977): 381, <http://www.jstor.org/stable/231314>. Sabatier also used a version of Lothar Meyer's atomic volume curve in his teaching.

Textbooks, of course, always lag behind the acceptance of new theories and new discoveries. So perhaps Venable and Howe were justified in thinking their textbook to be the first to be organized around the periodic classification. According to the historian Masanori Kaji, however, the first textbook to be based on the periodic law was written by Victor von Richter, a German-speaking chemist living within the Russian Empire. Richter's inorganic chemistry text was published in 1874 and no doubt benefitted from his having worked with Mendeleev in St. Petersburg during the 1860s.<sup>364</sup> The text was extremely popular, going through thirteen editions in Russian, as well as multiple editions in German, English, Dutch, and Italian, and “play[ing] a very important role in promulgating the periodic system not only in Russia but outside Russia as well.”<sup>365</sup>

Russian, German, English, and American texts were discussing the periodic system, if not actually organizing around it, by the 1880s. Other countries were much slower to adopt the periodic law and to incorporate it into their teaching. In Europe, French chemists were resistant to the atomic theory that was accepted by most chemists in other countries, therefore their textbooks were late in using the periodic system.<sup>366</sup> Chemists in Denmark were also slow to incorporate the periodic

---

<sup>364</sup> Masanori Kaji, “Mendeleev’s Discovery of the Periodic Law: The Origin and the Reception,” *Foundations of Chemistry* 5 (2003): 204, doi:10.1023/A:1025673206850. The text was V. von Richter, *Uchebnik neorganicheskoi khimii po noveishim vozzreniyam* (Warsaw, 1874).

<sup>365</sup> Masanori Kaji and Nathan Brooks, “The Early Response to Mendeleev’s Periodic System in Russia,” in Masanori Kaji, Helge Kragh, and Gábor Palló, eds., *Early Responses to the Periodic System* (New York: Oxford University Press, 2015), 28.

<sup>366</sup> The influential French chemist Berthelot criticized the periodic law in his book on alchemy, fearing that it would throw chemistry “into a mystic enthusiasm parallel to that of the alchemists.” See Nye, “Nonconformity,” 380.

law into teaching, due to the fact that one chemist, who was opposed to the periodic law, gave most of the university lectures in inorganic chemistry. The first textbook to discuss it was not published until 1890 and then it was without mention of Mendeleev.<sup>367</sup> Italian chemists, by contrast, were more accepting. Richter's inorganic textbook was translated in 1885 by Augusto Piccini, who also wrote several works advocating Mendeleev's system and making it well-known in the Italian chemical community.<sup>368</sup> Japan had little contact with Western science before 1868 when rapid modernization began and early textbooks were translations of Western texts. By 1890-1891, chemistry textbooks began to be written by Japanese chemists and, with little need to adhere to older Western traditions, were more inclined to include newer ideas such as the periodic system.<sup>369</sup>

By 1890, then, the periodic law had made its way into chemical pedagogy in most of the Western world. Although it was seen as an important tool in the teaching of chemistry, there was still no consensus as to the best visual representation of it. The commercial production of periodic table wall charts could be seen as a means of creating consensus – both the Central Scientific Company in

---

<sup>367</sup> Helge Kragh, "The Reception of the Periodic System in Denmark," in A. Roca-Rosell, ed., *The Circulation of Science and Technology: Proceedings of the 4<sup>th</sup> International Conference of the ESHS* (Barcelona: SCHCT-IEC, 2012): 525-530, [http://4eshs.iec.cat/entrada.asp?epigraf\\_contingut=18](http://4eshs.iec.cat/entrada.asp?epigraf_contingut=18).

<sup>368</sup> Marco Ciardi and Marco Taddia, "Piccini, Ciamician and the Periodic Law in Italy," in A. Roca-Rosell, ed., *The Circulation of Science and Technology: Proceedings of the 4<sup>th</sup> International Conference of the ESHS* (Barcelona: SCHCT-IEC, 2012): 531-535, [http://4eshs.iec.cat/entrada.asp?epigraf\\_contingut=18](http://4eshs.iec.cat/entrada.asp?epigraf_contingut=18).

<sup>369</sup> Masanori Kaji, "Chemical Classification and the Response to the Periodic Law of Elements in Japan in the Nineteenth and Early Twentieth Centuries," in Masanori Kaji, Helge Kragh, and Gábor Palló, eds., *Early Responses to the Periodic System* (New York: Oxford University Press, 2015), 289.



the United States and C. Gerhardt in Germany sold a wall chart based on Mendeleev's 1871 short form table. But the use of a wall chart was not required. And even if a classroom had one of the commercial charts, there was no guarantee that the teacher was inclined to use it or that the textbook used would include the same table. The use of multiple, or even no, tables could be a source of confusion, especially for students who moved from secondary education to universities, making the need for consensus increasingly important.

### **The Surprising Elements**

In the final years of the nineteenth century, the periodic law was well-established and visual representations were rife. However, there was still more for chemists to learn about the elements. In his first tables Mendeleev had predicted the existence of 16 new elements, though by 1890 only three of these had been discovered.<sup>370</sup> Yet elements not predicted by him were also being announced as newly discovered, particularly amongst the groups of elements which encompassed the rare earths. In 1868, Lockyer had declared the existence of the "theoretical" element, helium, which he identified in the spectra of the sun. But no one predicted what Lord Rayleigh, a physicist, and William Ramsay, a chemist, announced at the Royal Society on 31 January 1895.<sup>371</sup> After multiple and careful experiments, with confirmation given by other scientists, Rayleigh and Ramsay declared they had

---

<sup>370</sup> Mendeleev made predictions throughout his life. This number comes from Eric Scerri, *The Periodic Table: Its Story and Its Significance* (New York: Oxford University Press, 2007), 142.

<sup>371</sup> Lord Rayleigh and William Ramsay, "Argon, A New Constituent of the Atmosphere," *Philosophical Transactions of the Royal Society of London* 186A (1895): 187-241, <http://www.jstor.org/stable/90645>.

discovered a new gas which resisted all attempts to combine it with other elements and compounds. They named it argon, from the Greek word for idle.

Speculation was rife. Was this gas a new element or a mixture of elements? If it was a new element, with an atomic weight of about 40, then there was no place for it in the periodic system. As the account of the meeting in *Nature* suggested, “The easiest way out of the difficulty is to suppose that argon is a mixture.” Rayleigh and Ramsay agreed that there was evidence to support it being a mixture, but there was also evidence to suggest it was not. *Nature* argued that “[t]he periodic classification of the elements cannot, and ought not, to be abandoned at the first challenge,” and awaited further experimental evidence to answer the question.<sup>372</sup> The pages of *Nature* and the *Chemical News*, as well as other scientific journals, were quickly filled with papers and letters commenting one way or the other.

Rayleigh and Ramsay stayed publicly silent on the matter of the possible placement of argon in the periodic system. Ramsay, however, had written to Rayleigh on 24 May 1894, “Has it occurred to you that there is room for gaseous elements at the end of the first column of the periodic table?”<sup>373</sup> He also suggested that gases in this column, Group VIII, should occur in groups of three, with almost identical atomic weights.<sup>374</sup> Ramsay continued experiments on nitrogen, from which he and Rayleigh had first isolated the new gas, as well as on argon. In due course, he discovered another new gas, Lockyer's “theoretical” element, helium. The

---

<sup>372</sup> “Argon,” *Nature* 51 (1895): 337-338, doi:10.1038/051337a0.

<sup>373</sup> Morris W. Travers, *A Life of Sir William Ramsay, K.C.B., F.R.S.* (London: Edward Arnold (Publishers) Ltd., 1956), 110.

<sup>374</sup> Travers, *A Life*, 137.

discovery was announced in a paper read before the Chemical Society on 20 June 1895. Again, Ramsay and his colleagues were reluctant to render judgment on the placement of helium within the periodic system, concluding, "Until more experiments have thrown further light on the subject, we regard it as labour lost to discuss the relations of these curious elements to others which find their proper place in the periodic table."<sup>375</sup>

Ramsay continued experimenting with the new gases. In his 1897 Presidential Address to the Chemical Section of the British Association for the Advancement of Science, Ramsay speculated on the existence of another inert gas, one with an atomic weight between that of helium and of argon.<sup>376</sup> As he had suggested to Rayleigh in the letter of 1894, Ramsay drew attention to the fact that the last group of the periodic table contained three sets of three elements: iron, cobalt, and nickel; palladium, rhodium, and ruthenium; and platinum, iridium, and osmium. There was, he suggested, room for a fourth or even a fifth set of elements in this group. He noted that, just as Döbereiner had illustrated in 1817 in his theory of triads, there are several sets of three elements in which the atomic weight of the second element has a difference of between 16 and 20 from the first and third elements, adding up to a difference of 36. For example, in the group carbon, silicon, and titanium, silicon's atomic weight is just over 16 more than carbon and almost 20 less than titanium. Following this reasoning, Ramsay suggested there was an as-yet-

---

<sup>375</sup> William Ramsay, J. Norman Collie, and Morris Travers, "Helium, A Constituent of Certain Minerals," *Nature* 52 (1895): 334, doi:10.1038/052331a0.

<sup>376</sup> William Ramsay, "An Undiscovered Gas," *Chemical News* 76 (1897): 91-93, 97-99, <https://hdl.handle.net/2027/wu.89099510240?urlappend=%3Bseq=99>.

undiscovered gas between helium, atomic weight of 4, and argon, atomic weight of 40.<sup>377</sup>

This method of using the periodic law, or at least the triads of Döbereiner, to discover a new element was one which Ramsay also described to the German Chemical Society in December of 1898, at which time he was also able to relate his success in discovering more gaseous elements.<sup>378</sup> Ramsay and his assistant, Morris Travers, had been engaged in searching for this as-yet-undiscovered gas since the discovery of helium. In a matter of weeks, they discovered not only the suggested gas, neon with an atomic weight of 20, but two other gases, as well, krypton and xenon.<sup>379</sup> These gases seemed to form a complete series, but there was still the question of where to place them within the periodic system. In a paper read before the Royal Society in November 1900, Ramsay and Travers suggested that the gases formed a series between that of fluorine and of sodium.<sup>380</sup>

There was much speculation that the inert gases should be placed within Group VIII. This group was something of a catchall group for elements that did not quite fit into the other groups, a group which Howe had referred to as “a chemical Gehenna.” Ramsay had speculated to Rayleigh in 1894 there would be room for a

---

<sup>377</sup> Ramsay, “Undiscovered,” 92.

<sup>378</sup> William Ramsay, “The Recently Discovered Gases and Their Relation to the Periodic Law,” *Science*, n.s., 9 (1899): 273-280, <http://www.jstor.org/stable/1626430>. The speech was given in German and translated for *Science* by James Lewis Howe.

<sup>379</sup> William Ramsay and Morris W. Travers, “Argon and Its Companions,” *Philosophical Transactions of the Royal Society of London* 197A (1901): 47-89, <http://www.jstor.org/stable/90832>.

<sup>380</sup> William Ramsay and Morris W. Travers, “Argon and Its Companions,” *Nature* 63 (1900): 164-165, doi:10.1038/063164a0.

fourth and possible a fifth series of elements there.<sup>381</sup> But there were other suggestions, as well. In 1895, Thomsen suggested that a series of electrically null elements, with a valency of zero, would make sense as a transition between the electro-positive and electro-negative elements. Such a group would make the transition gradual, rather than sudden, “correspond[ing] to the gradual modification of the electrical character with the increasing atomic weight in the individual series of elements.”<sup>382</sup>

The Belgian scientist Léo Errera had come to a similar conclusion. He had done much work on the relationship between magnetism and atomic weight. In a paper on this topic read before the Belgian Academy of Science in March 1900, he displayed a periodic table with a new group, Group 0, which was located on the left-hand side of the table and contained helium, neon, argon, krypton, and xenon (Fig. 28).<sup>383</sup> Also in March 1900, Ramsay and Mendeleev both attended a meeting in Berlin, where they discussed the problem of placing the inert gases into the periodic system. Ramsay suggested that the inert gases should be placed in a new group, between Groups VII and I, and separate from Group VIII.<sup>384</sup> There is no evidence

---

<sup>381</sup> Travers, *A Life*, 110.

<sup>382</sup> Julius Thomsen, “On the Conjectural Group of Inactive Elements,” *Chemical News* 77 (1898): 120, <https://hdl.handle.net/2027/njp.32101075379519?urlappend=%3Bseq=128>. J. Thomsen, “Über die mutmassliche Gruppe inaktiver Elemente,” *Zeitschrift für anorganische Chemie* 9 (1895): 283-288, <https://hdl.handle.net/2027/uc1.b3959055?urlappend=%3Bseq=293>. Thomsen chose to illustrate this proposition through a circular diagram with four quadrants, very unlike the periodic system he had published earlier in 1895.

<sup>383</sup> L. Errera, “Magnetisme et poids atomique,” *Bulletin de la Classe des Sciences. Académie Royale de Belgique* 1900: 160-161, <https://hdl.handle.net/2027/njp.32101064104894?urlappend=%3Bseq=162>.

<sup>384</sup> Smith, “Persistence,” 459.

that Ramsay had any discussions with Errera and, in fact, he did not use the term Group 0 in his discussions with Mendeleev.

Séries.	Groupe 0.	Groupe I.	Groupe II.	Groupe III.	Groupe IV.	Groupe V.	Groupe VI.	Groupe VII.	Groupe VIII.		
1		H = 4,01									
2	He = 4	Li = 7,03 - très faible. (-)	Be = 9,4 + 700 ?	B = 11 + 50 ?	C = 12,00 - 50 + 7	Az = 14,01 ?	O = 16,00 + + (Quincke).	F = 19 (- 90) ?			
3	Ne = 20	Na = 23,05 (- 9) (-)	Mg = 24,36 + 11 (-)	Al = 27,1 + ?	Si = 28,4 + 0,08 + 7	Pb = 31,0 - 7 - (Quincke).	S = 32,06 - 11 - 16	Cl = 35,45 (- 90) ?			
4	A = 40	K = 39,15 (- 10) (-)	Ca = 40 (- 3) (-)	Sc = 44,4 ?	Ti = 48,4 + 90 ?	Y = 51,2 + 150 ?	Cr = 52,4 + +	Mn = 55,0 + +	Fe = 56,4 + +	Ni = 58,7 + +	Co = 59,0 + +
5	Kr > 85	Cu = 63,6 - 8,8 ?	Zn = 65,4 - 9,5 ?	Ga = 70 ?	Ge = 72 ?	As = 75 ?	Se = 79,4 - 15,5 (Quincke).	Er = 79,96 - 51,6 (Quincke).			
6	X > 85	Rb = 85,4 (- 90) (-)	Sr = 87,6 (- 90) (-)	Y = 89 + 5000? (+)	Zr = 90,7 - 14 (-)	Nb = 94 + 400? + 574 ?	Mo = 96,0 + 14 + 574 ?		Ru = 101,7 + +	Rh = 103,0 + +	Pd = 106 + 450 ?
7		Ag = 107,88 - 13,7 ?	Cd = 112,4 - 15 ?	In = 114 (- 10) ?	Sn = 118,5 + 4? + 7 ?	Sb = 120 - 69 - 18,8 (Quincke).	Te = 127 - 38,9 - 55,3 (Quincke).	I = 126,85 - 55,3 (Quincke).			
8		Cs = 133 (- 30) (-)	Ba = 137,4 (- 90) (-)	La = 138 + 13000 +	Ce = 140 + 5000 +	Pr = 140,5 + + 5000 ?	Nd = 143,6 + + 5000 ?	Sa = 150 ?		Gd = 156 + +	
9								(?) Er = 166 + 41000 (?)			
10				Yb = 173 + 7 ?		Ta = 183 + 1000? ?	W = 184 + 100 + 119 ?		Os = 191 + 74 ?	Ir = 193,0 + +	Pt = 195,8 + (Mouton) + 417 ?
11		Au = 197,2 - 30,7 ?	Hg = 200,5 - 20 - 18,8 (Quincke).	Tl = 204,4 + 7 ?	Pb = 206,5 - 14,3 - 95 ?	Bi = 208,5 - 95 - 95 (Quincke).					
12					Th = 232,5 + 10000? ?		U = 238,5 + 910 + 4 ?				

Figure 3.28: Errera's Table (1900)

Mendeleev was accepting of this idea. The seventh edition of his *Principles of Chemistry* makes use of the Group 0 idea and he discussed it in his monograph *A Chemical Conception of the Ether*. The placement of argon and the other inert gases into the periodic system was “a critical test for the periodic law” which passed with “perfect success.”<sup>385</sup> The successful passing of this “critical test” helped to earn Ramsay the Nobel Prize in Chemistry for 1904. The prize was awarded “in recognition of his services in the discovery of the inert gaseous elements in air, and his determination of their place in the periodic system.”<sup>386</sup> This was the only Nobel

<sup>385</sup> D. Mendeleeff, *A Chemical Conception of the Ether*, trans. George Kamensky (London: Longmans, Green, and Co., 1904), 21, <https://books.google.com/books?id=9dIygNQjvn0C>.

<sup>386</sup> Nobel Foundation, “The Nobel Prize in Chemistry 1904,” [http://www.nobelprize.org/nobel\\_prizes/chemistry/laureates/1904/](http://www.nobelprize.org/nobel_prizes/chemistry/laureates/1904/). Rayleigh won the Nobel Prize in Physics the same year for his work on the densities of gases

Prize awarded which made mention of the periodic system, showing that by 1904 the periodic law was firmly accepted and no longer considered to be a novel idea, a criteria for the awarding of the Prize.<sup>387</sup>

\*\*\*\*\*

By the end of the nineteenth century, the periodic law was firmly in place. Practical experiment, along with the judicious use of theory, had shown it to be largely accurate. It had proven its ability to adapt, easily accommodating new elements, both those predicted and those of a surprising nature. It had also been used to bolster theories regarding the unity of matter and the evolution of the elements, despite the fierce opposition of Mendeleev. The periodic system had largely solved the problem of how to classify the elements, but it could not solve all of the problems related to them.

Chemists turned towards an increasing number of international venues for assistance. The creation of an International Committee on Atomic Weights<sup>388</sup> at the turn of the century largely settled the question of which standard to use as the basis for the determination of atomic weights, H=1 or O=16, as members designated by

---

and the discovery of argon; Nobel Foundation, "The Nobel Prize in Physics 1904," [http://www.nobelprize.org/nobel\\_prizes/physics/laureates/1904/](http://www.nobelprize.org/nobel_prizes/physics/laureates/1904/).

<sup>387</sup> Mendeleev was nominated for the Nobel Prize in 1906, however controversy arose over whether or not the periodic law could be considered novel (and there were political machinations, as well) and the prize was instead awarded to Henri Moissan for his discovery of fluorine and the development of the electric furnace which bore his name. See Ulf Lagerkvist, *The Periodic Table and a Missed Nobel Prize* (Hackensack, NJ: World Scientific, 2012).

<sup>388</sup> For a fuller history of the International Committee on Atomic Weights, today the Commission on Isotopic Abundances and Atomic Weights of the International Union of Pure and Applied Chemistry, see Norman E. Holden, "Atomic Weights and the International Committee – A Historical Review," *Chemistry International* 26 (2004), doi:10.1515/ci.2004.26.1.4.

chemical and scientific associations from eleven countries,<sup>389</sup> voted overwhelmingly in favor of using O=16.<sup>390</sup> At the International Chemical Congress held in Paris in 1900, it was decided that elements were not to be considered officially recognized until they had appeared on the international table of atomic weights.<sup>391</sup> A new element was generally added to the table when the members of the International Committee on Atomic Weights agreed that it should be. While the inclusion of a substance into the atomic weights table as a sign of its status as an element did not solve the problem of the proliferation of new elements, it certainly cleared up some of the confusion.

Also becoming a matter of confusion at the end of the nineteenth century was visual representation of the periodic law. There was increasing proliferation and use of different visual representations – spirals, helices, and tabular forms – created for multiple purposes. Some were designed to illustrate theories about the

---

<sup>389</sup> There was a representative from Russia, however his vote was not received. Denmark, France, and Norway did not designate representatives to the committee. V., "Hydrogen or Oxygen as Basis of Atomic Weights - Which?," *Western Druggist* 22 (1900): 414-416, <https://books.google.com/books?id=7tPnAAAAMAAJ>; J[ames] L[ewis] H[owe], "Second Report of the Committee of the German Chemical Society on Atomic Weights," *Science*, n.s., 12 (1900): 246-247, <http://www.jstor.org/stable/1629662>.

<sup>390</sup> The breakdown of the seven dissenters is interesting. John Mallet, an Irish chemist who lived in the United States for the majority of his life, voted for H=1 as the basis of atomic weights. The other chemists who voted for H=1 were the representatives from the German associations other than the Deutsche chemische Gesellschaft. These German chemists published an argument for H=1 and attempted to reopen the question. J. Bredt, et al., "International Commission on Atomic Weights," *Chemical News* 82 (1900): 66, <https://hdl.handle.net/2027/njp.32101075380020?urlappend=%3Bseq=74>.

<sup>391</sup> G. Urbain, "Twenty-five Years of Research on the Yttrium Earths," *Chemical Reviews* 1 (1924): 173, doi:10.1021/cr60002a001. I have not located a review of the Congress that mentions this decision.



evolution of the elements. Others were created as part of research into the development of the periodic law. Although Mendeleev's 1871 short form table had become entrenched enough that most chemists were comfortable referring to it as "Mendeleev's table" with the expectation that others would know exactly which table was meant, this table had many deficiencies. Attempts to fix these deficiencies led to the creation of many more tables, most often for pedagogical purposes. The periodic law was integral to chemical education, used as the basis for organizing courses and textbooks, as well as for its visual representations.

**CHAPTER 4**  
**“THE OLD AND THE NEW”:**  
**THE PERIODIC LAW IN THE ERA OF RADIOACTIVITY, 1896-1914**

**Introduction**

The discovery of radioactivity is often described in encyclopedias and textbooks as revolutionary. It led to a new science which met at the borderlands of chemistry and physics. It created new fields within both of those sciences, from nuclear physics to cosmochemistry.<sup>392</sup> It impacted the other sciences, as well, from geology<sup>393</sup> to biology<sup>394</sup> and medicine.<sup>395</sup> It redefined our understanding of the building blocks of nature, of the elements and of atoms. In retrospect, historians see the discovery of radioactivity as stimulating revolutionary changes in science. But at the time, there was no such consensus. Frederick Soddy, the British chemist who was at the forefront of radioactivity research, was one of those who saw continuity with current scientific ideas rather than radical new ones. “Although on the surface

---

<sup>392</sup> See *Chemical Sciences in the 20<sup>th</sup> Century: Bridging Boundaries*, Carsten Reinhardt, ed. (Weinheim: Wiley-VCH, 2001), and Jeff Hughes, “Radioactivity and Nuclear Physics,” in *The Modern Physical and Mathematical Sciences*, ed. Mary Jo Nye, *The Cambridge History of Science*, vol. 5 (Cambridge: Cambridge University Press, 2002), 350-374.

<sup>393</sup> See Lawrence Badash, “Rutherford, Boltwood, and the Age of the Earth: The Origin of Radioactive Dating Techniques,” *Proceedings of the American Philosophical Society* 112 (1968): 157-169, <http://www.jstor.org/stable/986161>.

<sup>394</sup> See, for example, Luis A. Campos, *Radium and the Secret of Life* (Chicago: University of Chicago Press, 2015).

<sup>395</sup> See, for example, Angela N. H. Creager, *Life Atomic: A History of Radioisotopes in Science and Medicine* (Chicago: University of Chicago Press, 2013), and Matthew Lavine, *The First Atomic Age: Scientists, Radiations, and the American Public, 1895-1945* (New York: Palgrave Macmillan, 2013).

a revolutionary addition to the theories of physical science," he wrote in 1909, "it must be remembered that it is the *facts* of radioactivity that are really revolutionary," not any theory related to radioactivity. In his view, the theory he and his colleague, the physicist Ernest Rutherford, had developed to explain the phenomenon "conserves in a truly remarkable way the older established principles of physical science," reconciling "the old and the new."<sup>396</sup>

Others expressed similar feelings of continuity. In his presidential address before the British Association for the Advancement of Science (BA) meeting in 1906, E. Ray Lankester, the British zoologist, stated: "I think I am justified in saying that, exciting and of entrancing interest as have been some of the discoveries of the past few years, there has been nothing to lead us to conclude that we have been on the wrong path." Nothing, he continued, "which is really revolutionary" and "cannot be accepted by an intelligible modification of previous conceptions." He stressed that there was "continuity and healthy evolution within the realm of science."<sup>397</sup>

The following year, British chemist Arthur Smithells addressed the chemistry section at the BA meeting, excited that chemistry had never "been more interesting than it is at the present moment." However, the penalty of that excitement was perplexity and "the constant feeling of being left behind." Smithells sympathized with those suffering from such a feeling, suggesting:

---

<sup>396</sup> Frederick Soddy, *The Interpretation of Radium: Being the Substance of Six Free Popular Experimental Lectures Delivered at the University of Glasgow, 1908* (London: John Murray, 1909), 122.

<sup>397</sup> E. Ray Lankester, "Address," *Report of the Seventy-Sixth Meeting of the British Association for the Advancement of Science, York, August 1906* (London: John Murray, 1907), 5, <https://biodiversitylibrary.org/page/29741603>.

The perplexities of chemists these days do not come ... from the novelty of the ideas that are being presented to them, but from the great rapidity with which the whole science is growing, from the invasion of chemistry by mathematics and, in particular, from the sudden appearance of radio-activity with its new methods, new instruments, and especially with its accompaniment of speculative philosophy.<sup>398</sup>

Smithells expressed his “profound admiration for the masterly work” being accomplished by the “pioneers” of radioactivity.<sup>399</sup>

Neither Smithells nor Lankester were among the pioneers of radioactivity, so perhaps they were trying to accommodate this new discovery within their understanding of science by pointing to the continuity within science and the rapidity of discoveries. Others, however, were not so accommodating. German physicist Otto Hahn wrote to Rutherford in 1906 lamenting that people in his new institution, Emil Fischer’s Chemistry Institute, “know only very little on radioactivity. If they hear of something in connection with Ra [radium], they always seem skeptical.”<sup>400</sup> Some scientists were downright hostile, particularly chemists who deeply resented the increasing intrusion of physics into their science. The use of physical techniques in chemistry was becoming common, particularly in

---

<sup>398</sup> Arthur Smithells, “Presidential Address,” *Report of the Seventy-Seventh Meeting of the British Association for the Advancement of Science, Leicester, 31 July – 7 August, 1907* (London: John Murray, 1908), 476, <https://biodiversitylibrary.org/page/29717632>.

<sup>399</sup> Smithells, “Presidential Address,” 477.

<sup>400</sup> Quoted in Xavier Roqué, “From Radiochemistry to Nuclear Chemistry to Cosmochemistry,” *Chemical Sciences in the 20<sup>th</sup> Century: Bridging Boundaries*, ed. Carsten Reinhardt (Weinheim: Wiley-VCH, 2001), 123.

connection with the study of the elements,<sup>401</sup> but some chemists feared that physics – and physicists – were beginning take over their science.<sup>402</sup>

This chapter explores the collision between chemistry and physics that came with radioactivity. It begins with the discovery of the electron in the final years of the nineteenth century and ends with Moseley's discovery of x-ray spectroscopy just before the start of World War I. The rapid changes brought about by the discoveries of the internal structure of the atom and radioactivity forced chemists to confront what Marie Curie called "the chemistry of the invisible" – rays, subatomic particles, atoms that disintegrated. These were all things that could not be traditionally weighed and measured, or allowed for "the use of fingers in the laboratory." The practical as well as the theoretical nature of elements was called into question as more was learned about the invisible: Were elements really substances that could not be broken down? How could the large number of new radioactive elements fit into the periodic table?

---

<sup>401</sup> See, for example, Robert K. DeKosky, "Spectroscopy and the Elements in the Late Nineteenth Century: The Work of Sir William Crookes," *British Journal for the History of Science* 6 (1973): 400-423, <http://www.jstor.org/stable/4025503>; Frank A. L. James, "The Practical Problems of a 'New' Experimental Science: Spectro-Chemistry and the Search for Hitherto Unknown Elements in Britain, 1860-1869," *British Journal of the History of Science* 21 (1988): 181-194, <http://www.jstor.org/stable/4026978>.

<sup>402</sup> Chemists have frequently had to defend the borders of their discipline because, as Bernadette Bensaude-Vincent and Isabelle Stengers wrote, "their concepts and their methods formed nodes or crossroads among heterogeneous areas on the map of knowledge and because they held strategic but disputed places on that map"; *A History of Chemistry* (Cambridge: Harvard University Press, 1996), 5. See Bensaude-Vincent and Stengers for more on the question of identity in chemistry in the modern era, and Arnold Thackray, *Atoms and Powers: An Essay on Newtonian Matter-Theory and the Development of Chemistry* (Cambridge: Harvard University Press, 1970), for the influences on chemistry during the early modern period.

Despite their concerns, the discoveries that came with radioactivity reinforced rather than diminished the status of the periodic system as a fundamental theory of chemistry. The continuity of the periodic system translated into a continuity of its visual representation, as well. Despite the many recognized deficiencies of Mendeleev's table – the short form table – continued to be used in teaching, although textbooks increasingly contained multiple forms. The table only slowly incorporated the discoveries brought about by radioactivity – atomic number, the new underlying principle of the periodic law, was rarely to be found on the periodic tables in chemistry textbooks before the start of World War I. Their history with atomic weight made it difficult for chemists to make the change to atomic number – even those who embraced the changes wrought by radioactivity.

### **Chemists and the Electron**

Throughout the nineteenth century, atoms were generally understood to be indivisible particles that formed the elements and bonded together to form molecules, thereby acting as nature's building blocks. With the discovery in the late 1890s of subatomic particles – variously called, among other things, corpuscles, electrons, and electrions – physicists and chemists began to consider the idea that atoms were composed of smaller particles. Complete understanding of these subatomic particles would take decades to develop. But at the turn of the twentieth century, chemists struggled with the notion that the atom, so long thought to be indivisible, was composed of smaller portions of matter. Many outright denied the possibility, despite mounting empirical evidence.

Dmitri Mendeleev sensed the intrusion of physics into chemistry and, in developing a chemical conception of the ether,<sup>403</sup> sought to show the primacy of chemistry. “The atoms and molecules which are dealt with in all provinces of modern mechanics and physics,” he wrote, “cannot be other than the atoms and molecules defined by chemistry, for this is required by the unity of science.”<sup>404</sup> Mendeleev then defined the ether as an element, with an atomic weight one millionth that of hydrogen, sitting atop the zero group composed of the inert gases which had been recently discovered by William Ramsay. In doing so, Mendeleev noted that he “desired before all to extract from the periodic law that which it was able to give and to tangibly explain the materiality and universal presence of an ethereal substance throughout nature.”<sup>405</sup> The light weight of element x, the ether, and its ability to permeate “all substances, gaseous, liquid, and solid”<sup>406</sup> was an attempt to account for the newly discovered phenomenon of radioactivity. As for subatomic particles such as the electron, “those phenomena in which a division of atoms is recognised would be better understood as a separation or emission of the generally recognised and all-permeating ether.”<sup>407</sup>

---

<sup>403</sup> In the late nineteenth century, physicists theorized that the ether, or æther, was a medium for the propagation of light and electromagnetic radiation. It was considered to be fluid and to occupy the spaces between bodies. Ether was not unknown to chemists, but it the subject of little chemical research; see Helge Kragh, “The Aether in Late Nineteenth Century Chemistry,” *Ambix* 36 (1989): 49-65.

<sup>404</sup> D. Mendelèeff, *An Attempt Towards a Chemical Conception of the Ether*, trans. by George Kamensky (London: Longmans, Green, and Co., 1904), 6, <https://books.google.com/books?id=9dIygNQjvn0C>

<sup>405</sup> Mendelèeff, *An Attempt*, 43-44.

<sup>406</sup> Mendelèeff, *An Attempt*, 44.

<sup>407</sup> Mendelèeff, *An Attempt*, 17.

Mendeleev's chemical ether did not gain many adherents, and by 1905 most chemists had accepted the electron as a subatomic particle. Some chemists did take heed of Mendeleev's defining the ether as an element and attempted to do the same with the electron. The Swedish chemist and physicist J. R. Rydberg proposed in 1906 that the electron was an element, symbol E, with an atomic weight of 0. He fit it into the periodic table before hydrogen and in the same group as oxygen.<sup>408</sup> In somewhat similar vein, Ramsay offered a hypothesis in his presidential address before the Chemical Society in 1908. Electrons, he said, "are atoms of the chemical element, electricity, they possess mass; they form compounds with other elements; ... they serve as the 'bonds of union' between atom and atom"<sup>409</sup> Like Rydberg, Ramsay also assigned the symbol E to the "element" electron, however he did not comment on its place within the periodic system.

Historian Helge Kragh has suggested that this phenomenon of claiming the electron as an element was an attempt to appropriate the electron for chemistry.<sup>410</sup> Chemists felt that physicists were encroaching upon what they saw as the territory of chemistry, namely the atom. Chemists had earlier welcomed physicists's interest in furthering the understanding of the behavior of atoms. However, physicists quickly appropriated the atom.<sup>411</sup> The electron presented an opportunity for

---

<sup>408</sup> J. R. Rydberg, *Elektron der erste Grundstoff* (Lund: Hakan Ohlssons Buchdruckerei, 1906), 16, <https://books.google.com/books?id=BZIoAQAAMAAJ>.

<sup>409</sup> William Ramsay, "The Electron as an Element," *Journal of the Chemical Society, Transactions* 93 (1908), 778, doi:10.1039/CT9089300774.

<sup>410</sup> Helge Kragh, "Conceptual Changes in Chemistry: The Notion of a Chemical Element, ca. 1900-1925," *Studies in History and Philosophy of Modern Physics* 31 (2000): 438, doi:10.1016/S1355-2198(00)00025-3.

<sup>411</sup> Theodore Arabatzis and Kostas Gavroglu, "The Chemists' Electron," *European Journal of Physics* 18 (1997): 150, doi:10.1088/0143-0807/18/3/005.



chemists to reassert their claim to the atom and atomic theory, hence Mendeleev's statement that atoms and molecules must be defined by chemistry and the suggestions that the electron was an atom.

The idea that the electron was an element proved no more popular than that of Mendeleev's chemical ether. The chemically-inclined physicist J. J. Thomson,<sup>412</sup> who did much to experimentally determine its characteristics, tried to make the electron appealing to chemists in ways other than as an element. "The explanation which seems to me," he wrote in 1897,

to account in the most simple and straightforward manner for the facts is founded on a view of the constitution of the chemical elements which has been favourably entertained by many chemists: this view is that the atoms of the different chemical elements are different aggregations of atoms of the same kind.<sup>413</sup>

In the form of Prout's hypothesis, the "different aggregations of atoms" were hydrogen atoms, but if one substituted atoms of a primordial substance, following the view of Sir Norman Lockyer, then electrons could easily take the place of the primordial substance. Thomson speculated that the chemical atom was an aggregation of "primordial atoms" of differing electrical charges. Determining the configurations to make such an aggregation stable would be, he thought, "of great interest in connexion with the relation between the properties of an element and its atomic weight."<sup>414</sup>

---

<sup>412</sup> Textbooks generally state that J. J. Thomson discovered the electron in 1897. It is, of course, much more complicated than that. See *Histories of the Electron: The Birth of Microphysics*, Jed Z. Buchwald and Andrew Warwick, eds. (Cambridge, MA: The MIT Press, 2001).

<sup>413</sup> J. J. Thomson, "Cathode Rays," *Philosophical Magazine*, 5<sup>th</sup> ser., 44 (1897): 311, [https://hdl.handle.net/2027/uc1.\\$b785916?urlappend=%3Bseq=307](https://hdl.handle.net/2027/uc1.$b785916?urlappend=%3Bseq=307).

<sup>414</sup> Thomson, "Cathode Rays," 313.

In 1904, Thomson published an explanation of this model of the atom, often referred to as the plum pudding model. He posited that negatively-charged electrons orbited a positively charged region in stable rings. He also suggested that the structure of the atom had an effect on its properties and “that in particular the properties of the atom will depend upon its atomic weight in a way very analogous to that expressed by the periodic law.”<sup>415</sup> Thomson’s atomic model could not explain the periodic system but chemists were not reluctant to accept that it was suggestive of an underlying explanation. In 1895, Victor Meyer stated that “the knowledge that all chemical elements belong to a common series (which, since the discovery of the periodic law, practically no chemist denies) has established ... that a common something is present in all the elements.”<sup>416</sup> The electron was viewed by some as possibly being that “common something,” but there was as of yet no consensus on the matter. In the 1909 edition of his history of chemical theory, M. M. Pattison Muir referred to Ramsay’s suggestion that the electron was an element as mere “speculation” and encouraged his readers to study Mendeleev’s texts, including his conception of the ether. But Pattison Muir also specifically noted that “the electro-corpuseular theory [of J. J. Thomson] leads to the recognition of a

---

<sup>415</sup> J. J. Thomson, “On the Structure of the Atom: An Investigation of the Stability and Periods of Oscillation of a Number of Corpuscles Arranged at Equal Intervals Around the Circumference of a Circle; With Application of the Results to the Theory of Atomic Structure,” *Philosophical Magazine*, 6<sup>th</sup> ser., 7 (1904): 256, <https://books.google.com/books?vid=HARVARD:32044093608537>.

<sup>416</sup> Quoted in Helge Kragh, “The First Subatomic Explanations of the Periodic System,” *Foundations of Chemistry* 3 (2001): 130, doi:10.1023/A:1011448410646.

periodic connexion between the atomic weights and the properties of the elements."<sup>417</sup>

Pattison Muir appeared to be on the fence, but the physical chemist Harry C. Jones was much more enthusiastic about the electron and its possible explanation of the periodic system and Prout's hypothesis. In the third edition of his textbook, Jones stated:

*The electron is a unit charge of negative electricity, entirely disembodied from what we have hitherto regarded as matter. It is the ultimate unit of which all matter is composed. It is the fundamental unit of all the chemical atoms; the atom of one substance differing in the number and arrangement of the electrons contained in it.*<sup>418</sup>

Jones's ideas about the electron may not have been widely accepted by chemists, however, Jones still referred to an older concept of the elements, that espoused by John Dalton at the beginning of the nineteenth century and long since accepted by chemists. Dalton had stated that all atoms of an element were identical, thus all hydrogen atoms were the same and all nitrogen atoms were the same, but hydrogen atoms were not the same as nitrogen atoms. Could it be that, as Jones stated, the difference between atoms was the number and arrangement of electrons? Or, as research in the rapidly growing study of the phenomenon of radioactivity seemed to suggest, was there something more to atoms than mere electrons?

---

<sup>417</sup> M. M. Pattison Muir, *A History of Chemical Theories and Laws* (New York: John Wiley & Sons, 1909), 546, 374, <https://hdl.handle.net/2027/mdp.39015078650713>.

<sup>418</sup> Harry C. Jones, *The Elements of Physical Chemistry*, 3<sup>rd</sup> ed. (New York: The Macmillan Company, 1907), 41, <https://hdl.handle.net/2027/mdp.39015078163105>; emphasis in original.

## Radioactivity and the Radioelements

The phenomenon of radioactivity was first discovered in 1896 by the French physicist Henri Becquerel, when he noticed that uranium salts left sitting on a wrapped photographic plate in a drawer produced an image. Initially, radioactivity made little impression amongst either physicists or chemists. This was in part because the discovery was made only months after the discovery of x-rays by the German physicist Wilhelm Roentgen. X-rays had quickly captured the imagination not only of scientists, but also of the public, and were thus a popular research topic. The rays produced by uranium, on the other hand, were just one kind amongst many, authentic or otherwise, that were being discovered and studied in the wake of Roentgen's rays. In addition, few laboratories had the necessary uranium salts with which to experiment and pure metal uranium had only recently been prepared and was almost unobtainable.<sup>419</sup> Chemists on the whole found little of interest in radioactivity as they considered the study of rays to belong to the realm of physicists.<sup>420</sup>

Nevertheless, a few short years after its discovery, chemists, particularly the rare earths specialists, began to show an interest in radioactivity.<sup>421</sup> These chemists were long used to what historian John L. Heilbron called "heroic applications of the

---

<sup>419</sup> Lawrence Badash, "Radioactivity Before the Curies," *American Journal of Physics* 33 (1965): 130, doi:10.1119/1.1971267.

<sup>420</sup> H. W. Kirby, "The Discovery of Actinium," *Isis* 62 (1971): 290, <http://www.jstor.org/stable/229943>.

<sup>421</sup> As Lawrence Badash noted, these rare earth specialists "were both helped and hindered in their radioactivity thinking by their analogies between the two species of elements"; *Radioactivity in America: Growth and Decay of a Science* (Baltimore: Johns Hopkins University Press, 1979), 184. Comparisons between the two groups of elements were quickly struck down by radioactivists.

tedious methods of fractional crystallization” required to separate and isolate elements from mineral ores.<sup>422</sup> Such expertise was required as uranium, radium, and other radioactive substances were found in pitchblende, a mineral ore. Rare earths specialists were also among those chemists who regularly used physical techniques in their work and thus were more open to physics. Radioactivity research required an understanding of those rays that chemists had consigned to the realm of physics. It is not surprising, then, that radioactivity became a new field which existed in the borderlands between chemistry and physics. In his annual report on radioactivity for 1905, Soddy explicitly referred to the blending of chemistry and physics in this new field:

It is impossible to draw a distinction between researches which are more nearly physical and those which are mainly of chemical interest for it seems that the more clearly an investigation falls under the one head the more surely does it become indispensable to the other side of the subject.<sup>423</sup>

Those who engaged in radioactivity research began to refer to themselves as something more interdisciplinary than either chemists or physicists. They were radioactivists,<sup>424</sup> or “radioaktive Menschen.”<sup>425</sup>

---

<sup>422</sup> J. L. Heilbron, *H. G. J. Moseley: The Life and Letters of an English Physicist, 1887-1915* (Berkeley: University of California Press, 1974), 93.

<sup>423</sup> Frederick Soddy, “Radioactivity,” *Annual Reports on the Progress of Chemistry* 3 (1906): 333, doi:10.1039/AR9060300333.

<sup>424</sup> The term radioactivist was used by the scientists themselves, however historians of science have begun using it more frequently since the completion of Jeff Hughes' dissertation; Jeffrey Alan Hughes, “The Radioactivists: Community, Controversy and the Rise of Nuclear Physics,” PhD dissertation (Cambridge University, 1993).

<sup>425</sup> The German phrase can be found in a letter written to Rutherford by the Austrian physicist Franz S. Exner; quoted in Xavier Roqué, “From Radiochemistry,” 127.

This is not to say that all chemists involved in radioactivity research were as knowledgeable about physics as the physicists, and vice versa. Historian Lawrence Badash noted, for example, that Rutherford became adept enough at chemical methods to do some work in the laboratory, but he usually required the assistance of a trained chemist.<sup>426</sup> Bertram B. Boltwood, an American chemist active in radioactivity research, willingly engaged with Rutherford and other physicists but had little interest when their talk turned towards strictly physical matters.<sup>427</sup> Despite the fact that disciplinary identities remained, radioactivity workers were more likely to unite than divide when their work was misunderstood or attacked.

The tension engendered by radioactivity – between chemists and physicists and between those who were actively engaged in radioactivity research and those who were not – is illustrated by a series of events that took place during the summer of 1906. The British Association held its annual meeting at York in August. Section A, the section for physics and mathematics, held a discussion on “Radio-activity and the Internal Structure of the Earth,” with opening remarks by R. J. Strutt.<sup>428</sup> Another

---

<sup>426</sup> Rutherford won the Nobel Prize for Chemistry in 1908, a situation many chemists did not find amusing.

<sup>427</sup> *Rutherford and Boltwood: Letters on Radioactivity*, ed. Lawrence Badash (New Haven: Yale University Press, 1969), 21, also note 1 on 147.

<sup>428</sup> R. J. Strutt, “Discussion on Radio-activity and the Internal Structure of the Earth,” *Report of the Seventy-Sixth Meeting of the British Association for the Advancement of Science, York, August 1906* (London: John Murray, 1907), 491-492, <https://biodiversitylibrary.org/page/29742097>. Accounts of the discussion can be found in “Radio-activity,” *Chemical News* 94 (1906): 125, <https://hdl.handle.net/2027/wu.89099510216?urlappend=%3Bseq=407>, William Crookes, “On Radio-activity and Radium,” *Chemical News* 94 (1906): 125, <https://hdl.handle.net/2027/wu.89099510216?urlappend=%3Bseq=407>, and A. W. P., “Physics at the British Association,” *Nature* 74 (1906): 453-456, doi:10.1038/074453a0.

discussion in Section A, opened by Soddy, occurred on the evolution of the elements.<sup>429</sup> As the American journal *Electrical World* reported, somewhat tongue in cheek, “Since the radioactivists captured section A, they have ... made debates uncomfortably warm within that section.”<sup>430</sup> After the meeting, the uncomfortably warm debate engendered by these two sessions on radioactivity spilled into the public sphere through a series of letters in *The Times*.<sup>431</sup>

The exchange began when the eminent physicist Lord Kelvin wrote to *The Times* regarding its account of the discussion held on the evolution of the elements.<sup>432</sup> Soddy’s and Ramsay’s experimental discovery that helium was produced from radium, he stated:

brilliantly interesting as it is, and solidly instructive as it is towards the theory of radium, suggests nothing more towards any modification of the atomic doctrine proposed some 2,500 years ago by Democritus and universally adopted by chemists and other philosophers in the 19<sup>th</sup> century.<sup>433</sup>

He also objected to the new theory that the internal heat of the earth was due to radium, a theory that contradicted his own views on the heat of the earth.<sup>434</sup> He

---

<sup>429</sup> F. Soddy, “The Evolution of the Elements,” *Report of the Seventy-Sixth Meeting of the British Association for the Advancement of Science* (London: John Murray, 1907), 122-131, <https://biodiversitylibrary.org/page/29741724>. An account of the discussion can be found in “Physics at the British Association.”

<sup>430</sup> “York meeting of the British Association for the Advancement of Science,” *Electrical World* 48 (1906): 471, <https://hdl.handle.net/2027/uc1.c2662337?urlappend=%3Bseq=499>.

<sup>431</sup> In all, thirteen letters by eight scientists were published in *The Times* between August 9 and September 4, 1906.

<sup>432</sup> “British Association,” *Times* (London), August 4, 1906: 10.

<sup>433</sup> Kelvin, “Radium,” *Times* (London), August 9, 1906: 3.

<sup>434</sup> Kelvin’s theory of the heating and cooling of the earth was tied to his calculation of the age of the earth, which he believed to be 20 million years. See Frank D. Stacey, “Kelvin’s Age of the Earth Paradox Revisited,” *Journal of Geophysical Research* 105 (2000): 13155-13158, doi:10.1029/2000JB900028.

concluded: “the experimental results on which the radium hypothesis has been built give no foundation on which it can rest.”<sup>435</sup>

Henry E. Armstrong, a chemist who had strong objections to the increasing influence of physics on chemistry, quickly followed with a letter expressing his own concerns. Reiterating remarks made at the BA meeting, he opined, “physicists are strangely innocent workers; formulæ and fashion appear to exercise an all-potent influence over them.” In his view, this seemed to extend to all those who worked with radium as they “appear to have cast caution to the winds, and to have substituted pure imagination for it.” Until “proof” had been given, scientists should not make claims about radium, especially as “No one has yet handled ‘radium’ in such quantity or in such manner that we can say what it is precisely.”<sup>436</sup>

Neither Armstrong nor Kelvin were engaged in radioactivity research. However, Kelvin expressed an interest in radioactivity and claimed to be active in reading about ongoing experiments and other activities. In a letter to Armstrong written at the same time the debate was occurring in *The Times*, Kelvin stated: “I admire most sincerely and highly the energy of the workers in Radioactivity and the splendid experimental results which they have already got by resourceful and inventive experimental skill and laborious devotion.” At the same time, he regarded the notion that radium atoms disintegrated as “wantonly nonsensical” and implying “a thorough misunderstanding of the meaning of the word energy.”<sup>437</sup>

---

<sup>435</sup> Kelvin, “Radium,” *Times*, 3.

<sup>436</sup> Henry E. Armstrong, “Radium,” *Times* (London), August 10, 1906: 6.

<sup>437</sup> Kelvin to Armstrong, 13 September 1906, quoted in H. E. Armstrong, “Presidential Address,” *Report of the Seventy-Ninth Meeting of the British Association*



Kelvin had hoped that his letter to *The Times* would serve to enlighten the public about radioactivity. The succeeding series of letters failed to do so, only confusing the interested public with debates over different forms and interpretations of evidence as well as showcasing divisions within science. One such division was evident in the response of Oliver Lodge, a physicist, to the remarks of Armstrong. Lodge placed Armstrong among a group of “a few other chemists [who] have before now shown themselves scornful of chemical results obtained by physical means.”<sup>438</sup> This disciplinary divide between chemistry and physics was one that the radioactivists felt keenly, as their work frequently required crossing it. Soddy, in his summary of this “radium controversy” in the pages of *The Times*, stated the best argument against Lodge’s “favourite theme” that chemists have instincts while physicists use reason was the history of radioactivity itself, for it “owes at least as much to the chemist as to the physicist.”<sup>439</sup>

The radioactivists keenly felt another divide, as well. As Arthur Stewart Eve stated in a letter to *The Times*: “The recent discussion in your columns has resulted in a goodly crop of errors, written by those who have contented themselves with reading rather than with research work.”<sup>440</sup> Soddy concurred: “It would be a pity if

---

*for the Advancement of Science, Winnipeg: 1909* (London: John Murray, 1910), note on 428, <https://biodiversitylibrary.org/page/29718613>.

<sup>438</sup> Oliver Lodge, “Radium,” *Times* (London), August 15, 1906: 4.

<sup>439</sup> F. Soddy, “The Recent Controversy on Radium,” *Nature* 74 (1906): 516-518, doi:10.1038/074516c0. In response to Soddy’s summary, there was a short letter from Kelvin and a longer letter from Rutherford. See Kelvin, “The Recent Radium Controversy,” *Nature* 74 (1906): 539, doi:10.1038/074539a0, and E. Rutherford, “The Recent Radium Controversy,” *Nature* 74 (1906): 634-635, doi:10.1038/074634b0.

<sup>440</sup> A. S. Eve, “Radium.” *Times* (London), August 28, 1906: 6.

the public were misled into supposing that those who have not worked with radioactive bodies are as entitled to as weighty an opinion as those who have.”<sup>441</sup> While the radioactivists seemed to feel that no one could understand radioactivity without engaging in research, the historian Xavier Roqué has argued that it was an issue of evidence: “while some judged it sufficiently extensive and compelling, others felt that ‘a vast fabric of speculation’ had been reared upon ‘a narrow basis of solid experimental facts’.”<sup>442</sup> Evidence was important to chemists, whose science was more empirical than theoretical, particularly when it came to the elements. Radium – and radioactivity – would test their limits as to what was acceptable and what was not.

### **The Problem of Radium**

Interest in radioactivity amongst chemists increased in 1900 due to a series of discoveries initially made by Marie and Pierre Curie. In 1898, Marie Curie discovered that the element thorium emitted rays similar to those that Becquerel had observed in uranium.<sup>443</sup> Only a few months later, the Curies announced they had discovered a new radioactive substance, similar in many respects to bismuth, which they proposed to name polonium.<sup>444</sup> The Curies believed that this new metal

---

<sup>441</sup> Soddy, “Recent Controversy,” 518.

<sup>442</sup> Roqué, “From Radiochemistry,” 123.

<sup>443</sup> Sklodowska Curie, “Rayons émis par les composés de l'uranium et du thorium,” *Comptes Rendus* 126 (1898): 1101-1103, <https://hdl.handle.net/2027/uc1.31822008913949?urlappend=%3Bseq=1109>.

<sup>444</sup> P. Curie, and S. Curie, “Sur une substance nouvelle radio-active, contenue dans la pitchblende,” *Comptes Rendus* 127 (1898): 175-178, <https://hdl.handle.net/2027/uc1.31822008929580?urlappend=%3Bseq=181>. English translation, “On Polonium: A New Radio-active Substance Contained in Pitchblende,” *Chemical News* 78 (1898): 49, <https://hdl.handle.net/2027/nyp.33433062748060?urlappend=%3Bseq=57>.

might be an element,<sup>445</sup> however Eugene Demarçay, one of the premiere spectrographers of the time, had been unable to distinguish a unique spectral line in the sample he had been given. Shortly thereafter the Curies and Gustave Bémont, a chemist working with them, announced the discovery of radium, another radioactive substance which they also believed to be a new element.<sup>446</sup> Radium had many of the same characteristics as barium and in this case Demarçay was able to detect a unique line in its spectrum.<sup>447</sup>

Several things about the work of the Curies caught the attention of chemists. They had been systematically testing all of the elements for signs of radioactivity and had been in contact with chemists to obtain samples for use in their work.<sup>448</sup> Although they were searching for the rays discovered by the physicist Becquerel, they had isolated and examined their new substances using “purely chemical

---

<sup>445</sup> Polonium would eventually be identified as Mendeleev's dvi-tellurium which he had predicted in a footnote in his 1889 Faraday Lecture. See Mendeléeff, “The Periodic Law of the Chemical Elements,” *Journal of the Chemical Society. Transactions* 55 (1889): 649, doi:10.1039/CT8895500634.

<sup>446</sup> P. Curie, Mme. P. Curie, and G. Bémont, “Sur une nouvelle substance fortement radio-active, contenue dans la pitchblende,” *Comptes Rendus* 127 (1898): 1215-1217,

<https://hdl.handle.net/2027/uc1.31822008929580?urlappend=%3Bseq=1229>.

English translation, “Radium: A New Body, Strongly Radioactive, Contained in Pitchblende,” *Chemical News* 79 (1899): 1-2,

<https://hdl.handle.net/2027/mdp.39015073139134?urlappend=%3Bseq=7>.

<sup>447</sup> Eug. Demarçay, “Sur le spectre d’une substance radio-active,” *Comptes Rendus* 127 (1898): 1218,

<https://hdl.handle.net/2027/uc1.31822008929580?urlappend=%3Bseq=1232>.

English translation, “The Spectrum of a Radio-active Substance,” *Chemical News* 79 (1899): 13,

<https://hdl.handle.net/2027/mdp.39015073139134?urlappend=%3Bseq=19>.

<sup>448</sup> Curie, “Sur une substance nouvelle,” 177. English translation, “On Polonium,” 49.

processes.”<sup>449</sup> The discovery of new substances, especially ones claimed to be new elements, was always of interest to chemists. That these substances were radioactive was not yet of great concern, but the fact that Demarçay had been given samples of the new substances and examined their spectra was important.

Given the large number of supposed new elements which had been “discovered” in the latter half of the nineteenth century, chemists were reluctant to bestow the label “element” on a substance until several criteria had been met. Writing somewhat scathingly of the supposed discovery of a new element in Canada in 1912, the Polish chemist Tadeusz Estreicher noted that any man of science would “establish some positive proofs of existence” by means of “the atomic weight, the spectrum, and some reactions.”<sup>450</sup> Until that information was provided, there was little reason to believe that any substance might be an element. Before polonium and radium – or any other radioactive substances – could be accepted as elements, what Frank W. Clarke referred to as “sufficiently precise data” needed to be determined.<sup>451</sup>

Establishing that polonium was an element would be a difficult task.

Polonium was difficult to isolate from pitchblende and it was especially difficult to

---

<sup>449</sup> Curie, Curie, and Bémont, “Radium,” 1. French original, “Sur une nouvelle substance,” 1215; “Deux d’entre nous ont montré que, par des procédés purement chimiques...”.

<sup>450</sup> T. Estreicher, “Canadium,” *Chemical News* 105 (1912): 119, <https://hdl.handle.net/2027/mdp.39015073139274?urlappend=%3Bseq=125>.

<sup>451</sup> Polonium and radium, as well as seven other “new” elements, were omitted from the 1899 American table of atomic weights due to “lack of sufficiently precise data.” F. W. Clarke, “Sixth Annual Report of the Committee on Atomic Weights. Results Published in 1898,” *Journal of the American Chemical Society* 21 (1899): 213, doi:10.1021/ja02052a006.

isolate from impurities which made it difficult to obtain a clear spectrum reading. The quantities isolated were so small as to be almost useless for traditional chemical methods for determining atomic weight. Its atomic weight would be first determined using mathematical means<sup>452</sup> in the decade following its discovery; most of its chemical and physical properties would not be determined until the development of nuclear reactors in the mid-twentieth century.<sup>453</sup>

The status of radium as an element would be easier to establish than that of polonium. The Curies and Bémont had provided some account of its chemical reactions and Demarçay had discovered a unique spectral line. But determining the atomic weight of this new substance was not an easy task. This was in part because the amount of the substance that had been isolated was extremely small and in part because it was difficult to separate the substance from barium. Through a series of fractionations, Marie Curie was able to determine the atomic weight of “strongly radio-active barium” (i.e., radium) to be “slightly higher than that of barium.”<sup>454</sup> The

---

<sup>452</sup> Once Rutherford had experimentally determined that alpha particles were helium atoms, it became easy to mathematically work out the atomic weights of most of the radio-elements. For his calculation of polonium’s atomic weight, see E. Rutherford, “Properties of Polonium,” *Nature* 82 (1910): 491-492, doi:10.1038/082491a0.

<sup>453</sup> K. W. Bagnall, “Polonium,” *Endeavour* 22 (1963): 61-64.

<sup>454</sup> Madame Sklodowska Curie, “Atomic Weight of the Metal in Radiferous Barium Chloride,” *Chemical News* 80 (1899): 281-282, <https://hdl.handle.net/2027/mdp.39015073139134?urlappend=%3Bseq=611>. French original “Sur le poids atomique du métal dans le chlorure de baryum radifère,” *Comptes Rendus* 129 (1899): 760-762, <https://hdl.handle.net/2027/uc1.31822009517749?urlappend=%3Bseq=768>.

atomic weights she found ranged from 140.0 to 145.8, while the atomic weight of barium was considered be in the area of 137.4.<sup>455</sup>

These facts did not convince all chemists that radium was indeed an element. Béla v. Lengyel, a chemist working at the university in Budapest, expressed his doubts in the *Chemical News* in 1900. "The existence of radium in radio-active barium compounds is established," he noted, "through the radio-activity, the spectrum, and the higher atomic weight." He expressed reservations about the fact that polonium, radium, and another new element that had recently been discovered and named actinium were all discovered in the same substance, pitchblende. He was also concerned that most of what was known about radioactive substances such as these was learned through experiments "conducted almost exclusively with reference to the rays emitted by these bodies." After conducting his own experiments, his results "d[id] not nearly suffice to decide the question as to whether radium is an existing chemical element, or not; but those facts render doubtful the existence of radium."<sup>456</sup>

Marie Curie continued to believe that radium was an element. She further refined the amount of the substance she had available to her until she was able to produce approximately one decigram of "perfectly pure" radium chloride. Using this extremely small amount, she was able to determine that the atomic weight of

---

<sup>455</sup> The first International Table of Atomic Weights had yet to be published when Curie's experiments were done. Clarke's report to the American Chemical Society in 1899 listed four different atomic weights for barium, three of which were close to 137.4. See Clarke, "Sixth Annual Report," 213.

<sup>456</sup> Béla v. Lengyel, "On Radio-active Barium," *Chemical News* 82 (1900): 25-26, <https://hdl.handle.net/2027/njp.32101075380020?urlappend=%3Bseq=33>.

radium was 225. Going even further than determining the atomic weight, Curie also described the place that radium should occupy within the periodic system. "From its chemical properties radium is an element of the alkaline-earthly series, and in this series it is the higher homologue of barium," she stated. "According to its atomic weight it should be placed in Mendeleff's table below barium in the alkaline-earthly series, and on the line with thorium and uranium."<sup>457</sup>

The confidence displayed by Marie Curie in her atomic weight determination, her placement of radium within the periodic system, and the unique line in the spectra was confirmation enough for many chemists to accept radium as a new element.<sup>458</sup> In his annual report on radioactivity for 1904, Soddy stated, "The evidence for considering radium to be a new element is of the same character and at least as definite as in the case of any of the older known elements."<sup>459</sup> He was not alone in the conferring the status of element upon radium. The American Chemical Society included radium for the first time on its atomic weight table for 1903. The

---

<sup>457</sup> Mdme. Curie, "On the Atomic Weight of Radium," *Chemical News* 86 (1902): 61, <https://hdl.handle.net/2027/mdp.39015073139100?urlappend=%3Bseq=395>. French original, "Sur le poids atomique du radium," *Comptes Rendus* 135 (1902): 161-163,

<https://hdl.handle.net/2027/uc1.31822009517798?urlappend=%3Bseq=167>.

<sup>458</sup> As Helge Kragh noted, chemists had awarded the status of element to substances without isolating it in a pure state. Indeed, Marie Curie won the Nobel Prize for Chemistry in 1911 in part for her work on isolating radium and the study of its properties. See Kragh, "Conceptual Changes," 439. Her emphasis on isolating metallic radium was partially due to her relationship with industry and with the evolving metrology of radioactive substances. See Xavier Roqué, "Displacing Radiochemistry," in *Instrumentation Between Science, State and Industry*, ed. Bernward Joerges and Terry Shinn (Dordrecht: Kluwer Academic Publishers, 2001), 51-68; and Soraya Boudia, "The Curie Laboratory: Radioactivity and Metrology," *History and Technology* 13 (1997): 249-265.

<sup>459</sup> Frederick Soddy, "Radioactivity," *Annual Reports on the Progress of Chemistry* 1 (1904): 248, doi:10.1039/AR9040100244.

report of the Committee on Atomic Weights noted that radium “appears as a definite element for the first time, taking its proper place in the periodic system as a member of the calcium, strontium, barium group.”<sup>460</sup> The International Committee on Atomic Weights also included radium for the first time in 1903, citing Marie Curie’s determination of its atomic weight as being “probably not far from the truth.”<sup>461</sup>

Despite the support of the International Committee, questions about the atomic weight of radium continued to be raised. The German mathematician Carl Runge, who was deeply interested in spectroscopy and its application to astronomy, undertook a study of the spark spectrum of radium. In 1903, he and Julius Precht, a physicist, calculated the atomic weight of radium by means of a mathematical formulation Runge had developed with another physicist, Friedrich Paschen. By their calculations, the atomic weight of radium was 257.8, a figure which was significantly higher than that determined by Marie Curie. Runge and Precht stated, “We do not venture to suppose that our value deserves more confidence than that determined by Mme. Curie.” However, they continued, given the extremely small quantities with which she was forced to work and the extreme difficulty of separating radium from barium it was possible that her calculations were “too small a value for the atomic weight.”<sup>462</sup> They did acknowledge that the atomic weight 225

---

<sup>460</sup> F. W. Clarke, “Tenth Annual Report of the Committee on Atomic Weights. Determinations Published in 1902,” *Journal of the American Chemical Society* 25 (1903): 223, doi:10.1021/ja02005a001.

<sup>461</sup> F. W. Clarke, “Report of the International Committee on Atomic Weights,” *Journal of the American Chemical Society* 25 (1903): 3, doi:10.1021/ja02003a001.

<sup>462</sup> C. Runge and J. Precht, “The Position of Radium in the Periodic System According to Its Spectrum,” *Philosophical Magazine*, 6<sup>th</sup> ser., 5 (1903): 480,



was “in better correspondence with the periodic system” as it would place radium in “the gap between bismuth and thorium in the proper column,” whereas a weight of 258 would place it in a different column requiring that “a number of new unoccupied places would be created in the periodic system.” They also commented that the higher weight was supported by “Rutherford’s remark” suggesting that a higher atomic weight indicated a more complex atomic structure which meant an element gave off more electrons.<sup>463</sup>

This intrusion into the determination of atomic weights by non-chemists did not sit well, particularly the seeming disregard for the periodic system, something chemists now viewed as fundamental to their understanding of the elements.

William Marshall Watts, a chemist who specialized in spectrum analysis, also used a mathematical relationship between spectral lines to calculate the atomic weight of radium. His figure came into close agreement with that of Marie Curie, the mean of his results being 224.89.<sup>464</sup> Watts and Runge then became involved in a disagreement in the pages of the *Philosophical Magazine* in which each accused the other of misunderstanding the connection between spectra and atomic weights, particularly when it came to determining the atomic weight of radium. Watts made further calculations in 1909 in which he came to a figure of 226.6 for the atomic

---

<https://hdl.handle.net/2027/njp.32101075715449?urlappend=%3Bseq=512>; “Die Stellung des Radium im periodischen System nach seinem Spektrum,” *Physikalische Zeitschrift* 4 (1902-1903): 287,

<https://hdl.handle.net/2027/njp.32101054770811?urlappend=%3Bseq=313>.

<sup>463</sup> Runge and Precht, “The Position,” 481; “Die Stellung,” 287.

<sup>464</sup> W. Marshall Watts, “On the Atomic Weight of Radium,” *Philosophical Magazine*, 6<sup>th</sup> ser., 6 (1903): 66,

<https://hdl.handle.net/2027/hvd.32044089572259?urlappend=%3Bseq=80>.

weight of radium. He wrote, "it seems desirable to place it [his formula] upon record, since it shows that the spectroscopic data are consistent with the atomic weight obtained for Radium by chemical methods"<sup>465</sup>

Not all chemists took offense at Runge's and Precht's calculations. Jones, the physical chemist at Johns Hopkins University, wrote in 1905 that "[t]he question of the atomic weight of radium cannot be regarded, as yet, as settled." He then discussed the two possible atomic weights, that of Marie Curie, made "by purely chemical means," and that of Runge and Precht, "based on a physical method."<sup>466</sup> The "most important" of the arguments laid out for the atomic weight of radium to be 225 was "based upon the position of radium in the periodic system."<sup>467</sup> Jones was of the opinion that radium would fit neatly into the periodic system, "in accord with all its chemical and physical properties," with a higher atomic weight of "slightly greater than 250" just as it would with the lower figure of 225. He felt radium, barium, and their homologues could fit neatly into Group II, albeit in a new series, series 13.<sup>468</sup> "[T]he evidence from the periodic system is certainly as strong, and in the opinion of the writer much stronger," Jones concluded, "in favor of a higher value, which would be very nearly that found by Runge and Precht."

---

<sup>465</sup> W. Marshall Watts, "On the Calculation of the Atomic Weight of Radium from Spectroscopic Data," *Philosophical Magazine*, 6<sup>th</sup> ser., 18 (1909): 413, <https://archive.org/details/londonedinburg6181909lond>.

<sup>466</sup> Harry C. Jones, "The Atomic Weight of Radium and the Periodic System," *American Chemical Journal* 34 (1905): 467, <https://hdl.handle.net/2027/umn.31951000617555l?urlappend=%3Bseq=487>.

<sup>467</sup> Jones, "The Atomic Weight," 468.

<sup>468</sup> Jones, "The Atomic Weight," 469.

However, the question of the atomic weight of radium would only be settled “after a considerable amount of pure material is available.”<sup>469</sup>

Because there was only a very small supply of radium available with which to make a determination of its atomic weight, the only experimental determination made was that by Marie Curie in 1902. Fueled by the amount of discussion that arose from Runge and Precht’s first paper, Marie Curie set out to make a second determination in 1907 and concluded that the atomic weight of radium was 226.4.<sup>470</sup> Before these results were published, the president of the Royal Society asked T. E. Thorpe, a chemist who was a member of the International Committee on Atomic Weights, to undertake the experimental determination of the atomic weight of radium. Thorpe’s experiments, the details of which were delivered in the 1907 Bakerian Lecture, yielded an atomic weight determination of 226.7, “in very close accord with Mme. Curie’s latest number,” he noted.<sup>471</sup>

The International Committee on Atomic Weights took note of Marie Curie’s experiments in their deliberations for 1907. However, they declined to change the

---

<sup>469</sup> Jones, “The Atomic Weight,” 471.

<sup>470</sup> Mdme. Curie, “The Atomic Weight of Radium,” *Chemical News* 96 (1907): 127, <https://hdl.handle.net/2027/mdp.39015073138953?urlappend=%3Bseq=467>. French original “Sur le poids atomique du radium,” *Comptes Rendus* 145 (1907): 422-425, <https://hdl.handle.net/2027/uc1.31822009517871?urlappend=%3Bseq=422>. Details of her experimental determination were published in “Sur le poids atomique du Radium,” *Le Radium* 4 (1907): 349-352, <https://books.google.com/books?vid=HARVARD:HX3LGV>.

<sup>471</sup> T. E. Thorpe, “Bakerian Lecture for 1907. – On the Atomic Weight of Radium,” *Proceedings of the Royal Society* 80A (1908): 298-309, <http://www.jstor.org/stable/92934>.

atomic weight of radium on the table.<sup>472</sup> Once Thorpe's results were published, the Committee accepted Marie Curie's value of 226.4 and accordingly changed the atomic weight of radium on the international table for 1909.<sup>473</sup> Others, most notably the Czech-Austrian chemist Otto Hönigschmid, continued experiments to refine the determination of the atomic weight of radium. In its report for 1916, the International Committee lowered the atomic weight slightly to 226.0, the figure commonly accepted today.<sup>474</sup>

Radium appeared to be firmly established as an element. Its spectrum had been identified and studied, its atomic weight determined and accepted by the International Committee. However, research into radium, in particular into its radioactive properties, caused chemists to question not only the status of radium as an element but the nature of elements in general. Although chemists had been using the tools of physics for decades in their experimental work, the ability to weigh and measure had been a mainstay of their science, particularly with regard to the elements. As historian Helge Kragh stated, "To most chemists, an element that could not be isolated and whose atomic weight could not be determined was not an

---

<sup>472</sup> F. W. Clarke, W. Ostwald, T. E. Thorpe, and G. Urbain, "Report of the International Committee on Atomic Weights. 1908," *Journal of the American Chemical Society* 30 (1908): 1-4, doi:10.1021/ja01943a001.

<sup>473</sup> F. W. Clarke, W. Ostwald, T. E. Thorpe, and G. Urbain, "Report of the International Committee on Atomic Weights. 1909," *Journal of the American Chemical Society* 31 (1909): 1-6, doi:10.1021/ja01931a001.

<sup>474</sup> F. W. Clarke, T. E. Thorpe, and G. Urbain, "Annual Report of the International Committee on Atomic Weights, 1916," *Journal of the Chemical Society, Transactions* 107 (1915): 1282-1285, doi:10.1039/CT9150701282.

element.”<sup>475</sup> Radioactive substances, including radium, were described by Marie Curie as “materials which, in all likelihood, can never be characterized as chemical elements, their destruction being too rapid.” Research into these substances, she said, was “a new chemistry that uses the electrometer as the main tool and not the scale”; it was “the chemistry of the invisible.”<sup>476</sup>

The invisible Marie Curie referred to were rays. From the discovery of x-rays by Roentgen in 1895, rays had been a prime area of research, particularly for physicists. As the radioactivists continued their study of radium and other radioactive substances, they discovered that these substances emitted rays. In 1901, Soddy and Rutherford were studying thorium and discovered that part of their thorium sample had turned into radium. Soddy later recalled that he blurted, “Rutherford, this is transmutation,” to which Rutherford replied, “For Mike’s sake Soddy, don’t call it *transmutation*. They’ll have our heads off as alchemists.”<sup>477</sup> They, of course, being chemists, who were long accustomed to thinking of elements as substances that could not be broken down into other substances by experiment.

Shortly thereafter, radioactivists began to discover that radioactive substances other than thorium and radium transmuted. It was determined that as

---

<sup>475</sup> Helge Kragh, “From Geochemistry to Cosmochemistry: The Origin of a Scientific Discipline, 1915-1955,” in *Chemical Sciences in the 20<sup>th</sup> Century: Bridging Boundaries*, ed. Carsten Reinhardt (Weinheim: Wiley-VCH, 2001): 163.

<sup>476</sup> Mdme. P. Curie, “Les Mesures en Radioactivité et l’Étalon du Radium,” *Journal de Physique Théorique et Appliquée* 2 (1912): 805, <https://hdl.handle.net/2027/uiug.30112105671686?urlappend=%3Bseq=805>; “C’est là une nouvelle chimie...”

<sup>477</sup> This exchange was recalled by Soddy in 1953, over 50 years after the fact, so how accurate that recollection was is unknown. Quoted in Muriel Howorth, *Pioneer Research on the Atom: The Life Story of Frederick Soddy* (London: New World Publications, 1958), 83-84.

radioactive atoms emit rays, those atoms disintegrate,<sup>478</sup> causing the transmutation from one substance into another. Three different kinds of rays were discovered: alpha ( $\alpha$ ), beta ( $\beta$ ), and gamma ( $\gamma$ ). Rutherford and Soddy, as a result of numerous experiments, concluded, “it is not possible to regard radioactivity as a *consequence* of changes that have already taken place. The rays emitted must be an *accompaniment* of the change of the radiating system into the next one produced.”<sup>479</sup> They showed that radioactivity was a property of the atom, not of any chemical or physical conditions. Thus radioelements, including the long accepted elements uranium and thorium disintegrated naturally, not as a result of any outside process. This seemed to contradict the commonly accepted dictum that a substance had to be considered an element until such a time in which chemists were able to show otherwise through analytical means.

The longer radioactivists studied radium, thorium, uranium, and the newly discovered element actinium, the more radioactive substances they found. Each substance decayed into another until a final end product was reached, thus forming a genetic relationship between the starting element (e.g., uranium) and the final end product. They varied wildly in terms of how long each lasted – some had half-lives of minutes or days, others of years. Radioactivists arranged these substances into disintegration series to quickly determine where a substance was in a series, or in

---

<sup>478</sup> The word “disintegrate” was used in the early years of radioactivity research, but the word “decay” is now commonly used instead. I will use both interchangeably.

<sup>479</sup> E. Rutherford, and F. Soddy, “Radioactive Change,” *Philosophical Magazine*, 6<sup>th</sup> ser., 5 (1903): 578, <https://hdl.handle.net/2027/njp.32101075715449?urlappend=%3Bseq=618>.

which series<sup>480</sup> (Fig. 1).<sup>481</sup> The problem, however, was that much like the rare earth elements, the same substances were often discovered by multiple people who sometimes believed each to be a different substance. Radio-tellurium, for example, was thought to be a new substance before it was determined to actually be polonium. There were also instances in which substances were found that fell into the disintegration series between two other previously found substances. The most extreme example of this was radium. Initially radium was thought to have its own disintegration series, until it was discovered that uranium was its parent substance, thus making radium and its series a part of the uranium series. The result was a complicated ensemble of substances with many names and substances that carried multiple and confusing names such as RaA, AcX, AcC', and Io. To further complicate matters, the radioactivists referred to all of these substances as radioelements, regardless as to whether or not they were commonly accepted as elements by chemists.

On the whole, radioactivists weren't too bothered by the plethora of names used for the radioelements. Marie Curie's laboratory regularly published tables of radioactive substances and constants, which provided a means for checking the latest information.<sup>482</sup> Rutherford wrote to Boltwood that "I care very little what it is

---

<sup>480</sup> These concepts and tools continue to exist within nuclear science albeit with slightly different terms. Genetic relationships are now referred to in terms of parent, daughter, and granddaughter substances. Disintegration series are now decay chains.

<sup>481</sup> E. Rutherford, *Radioactive Transformations* (New York: Charles Scribner's Sons, 1906), 169, <https://books.google.com/books?vid=HARVARD:32044106201734>.

<sup>482</sup> See, for example, G.-A. Blanc, et al., "Tables des constantes radioactives," *Le Radium* 6 (1909): 1-4, doi:10.1051/radium:01909006010100.

called ‘what’s in a name’ anyway.”<sup>483</sup> In a more public venue, Rutherford was a bit more circumspect, stating that “it will be very desirable for physicists and chemists to meet together in order to revise the whole system of nomenclature.” However, he went on, “There is not much to be gained in doing so immediately.”<sup>484</sup> It was generally agreed that not all radio-elements had yet been discovered so it seemed prudent to wait.

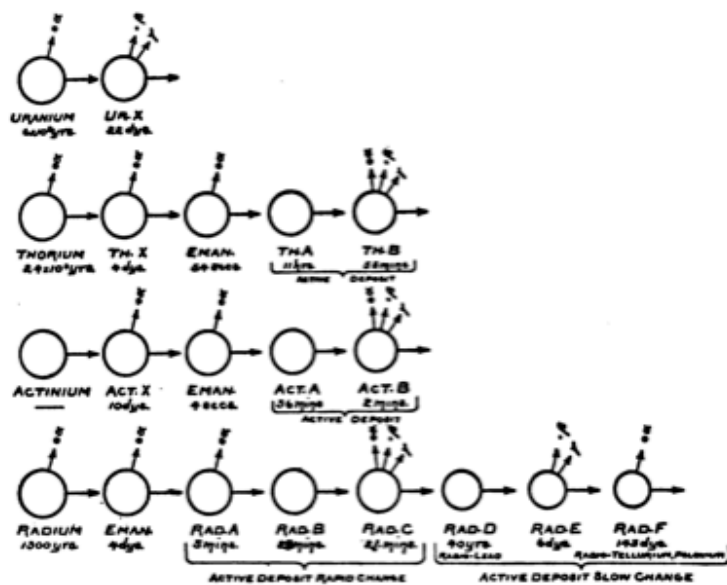

FIG. 41.

The radioelements and their family of products.

**Figure 4.1: Disintegration Series from Rutherford's *Radioactive Transformations***

The “system” which Rutherford referred to was an *ad hoc* one in which, for the most part, “the products arising successively from the disintegration of a radioactive element are denoted by the name of that element followed by the letters X, A,

<sup>483</sup> Rutherford to Boltwood, 24 November 1907, in *Rutherford and Boltwood*, 174.

<sup>484</sup> E. Rutherford, “Origin of Radium,” *Nature* 76 (1907): 661, doi:10.1038/076661b0.



B, C, &c.”<sup>485</sup> Radioactivists were not shy about straying from this plan and giving names such as ionium and mesothorium to the substances they discovered. This caused concern amongst both chemists and physicists who continued to call for something to be done.<sup>486</sup> In response to a letter on the subject from William H. Ross, Boltwood agreed this was an important topic, noting that “as I understand it the International Radium Standards Committee are going to take up the matter.”<sup>487</sup> The committee was due to meet at the third International Radiological Congress in Vienna in 1915, however World War I intervened, leaving the question of nomenclature unresolved.

Of deeper concern to chemists than a systematic nomenclature for the radioelements was the nature of the elements themselves. Radioactivity had called into question the definition of an element as a substance that could not be decomposed, or broken apart, by any known techniques. At the British Association meeting in Winnipeg in 1909, Armstrong questioned whether or not radium was an element. The answer, he said, “must depend on our definition of an element. At present we seem to be without one.”<sup>488</sup> In 1911, Emil Fischer informed an audience, which included Kaiser Wilhelm, that, “Owing to the discovery of radium and similar

---

<sup>485</sup> Norman R. Campbell, “The Nomenclature of Radio-activity,” *Nature* 76 (1907): 638, doi:10.1038/076638b0.

<sup>486</sup> Norman R. Campbell, “The Nomenclature of Radioactivity,” *Nature* 84 (1910): 203-204, doi:10.1038/084203b0; William H. Ross and H. Jermain Creighton, “A Plea for Uniformity in Radio-active Nomenclature,” *Nature* 91 (1913): 347, doi:10.1038/091347a0.

<sup>487</sup> Boltwood to Ross, 30 September 1913, Box 2, Folder 81, Bertram Bordon Boltwood Papers. Manuscripts and Archives, Yale University Library. Ross was a scientist with the Bureau of Soils, U.S. Department of Agriculture who was involved in the compilation of *Chemical Abstracts*.

<sup>488</sup> H. E. Armstrong, “Presidential Address,” 427.

bodies, we have been forced to the conclusion that chemical elements are not unalterable, and hence that atoms are not indivisible.”<sup>489</sup>

Theodore W. Richards agreed with Fischer that, “Within the last fifteen years the definition of these two words [atoms and elements] has been rendered somewhat uncertain, and bids fair to suffer even further change.” However, he was not convinced that chemists should be as concerned as Armstrong appeared to think. “For all practical purposes the elementary substances may still be regarded as undecomposed (even if not perhaps absolutely incapable of decomposition) in all our chemical considerations concerning earthly phenomena,” aside from the relatively few that are radioactive. Therefore chemists should be free to retain the term “chemical elements.”<sup>490</sup> Soddy argued that the elements were “ultimately compound,” which did nothing to take away from their status as elements. The spectrum of radium did not show either the spectrum of barium or of helium, or of any other element; it was unique, therefore radium was a chemical element and not a chemical compound.<sup>491</sup> Soddy felt these “questions of nomenclature” were “not of any great or lasting importance” and only served to “divert attention from the experimental *facts*.”<sup>492</sup> What the definition of an element should be was something that would need to wait another decade to be officially resolved.

---

<sup>489</sup> Emil Fischer, “Recent Advances and Problems in Chemistry,” *Nature* 85 (1911): 558, doi:10.1038/085558b0.

<sup>490</sup> Theodore W. Richards, “Atomic Weights,” *Journal of the American Chemical Society* 34 (1912): 960, doi:10.1021/ja02209a001.

<sup>491</sup> Soddy, *Interpretation of Radium*, 145.

<sup>492</sup> Soddy, *Interpretation of Radium*, 146.

## The Periodic System in Disarray?

By the end of the nineteenth century, the periodic system seemed to be an accepted fact of chemistry. It had several flaws yet those deficiencies were minor in comparison to its usefulness. It had weathered a major test with its ability to accommodate the newly discovered inert gases. With the discovery of more than twenty radio-elements, there were questions about how to accommodate them within the periodic table, assuming they could even be considered elements. Ramsay had little doubt that, much like the inert gases, the radio-elements would find their place. In his presidential address at the British Association meeting in 1911, he declared, "It is above all things certain that it would be a fatal mistake to regard the existence of such elements as irreconcilable with the periodic arrangement, which has rendered to systematic chemistry such signal service in the past."<sup>493</sup>

Given the difficulty of accommodating the rare earth elements, it is not surprising that some wondered if the radio-elements were similar to the rare earths. Addressing this possibility, Alexander Fleck unequivocally stated, "we are not dealing with substances similar to rare earths, and that there is no analogy between the two cases."<sup>494</sup> The problem with the rare earths was that they were difficult to

---

<sup>493</sup> William Ramsay, "President's Address," *Report of the Eighty-First Meeting of the British Association for the Advancement of Science, Portsmouth: 1911* (London: John Murray, 1912), 14, <https://biodiversitylibrary.org/page/29843514>.

<sup>494</sup> Alexander Fleck, "The Chemistry of the Radio-elements," *Chemical News* 108 (1913): 176, <https://hdl.handle.net/2027/mdp.39015073139282?urlappend=%3Bseq=513>. See also Frederick Soddy, *The Chemistry of the Radio-Elements, Part II: The Radio-Elements and the Periodic Law* (London: Longmans, Green and Co., 1914), 4-5.

separate and were very similar with regard to chemical properties, however they did have unique atomic weights. The radio-elements,<sup>495</sup> on the other hand, had the same atomic weights as already accepted elements but had very different chemical and physical properties than those elements.

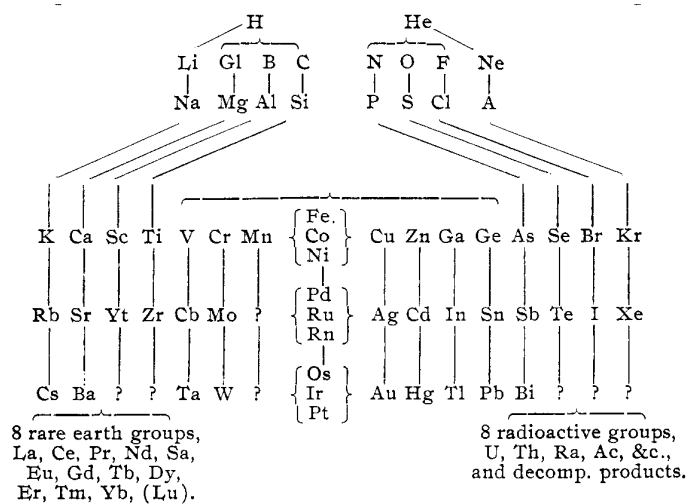

**Figure 4.2: Adams's 1911 Table**

Despite these different issues, some chemists found it easier to treat the rare earths and the radio-elements in similar fashion when creating their own periodic tables. In 1911, Elliot Quincy Adams published a periodic table that bore a resemblance to a Thomsen-Bayley table (Fig. 2).<sup>496</sup> He grouped the elements into six periods (represented by the horizontal rows) as well as into several families (the vertical columns). Adams found that the rare earths and the radio-elements were “not homologous to any previous elements” and instead were “two groups of

<sup>495</sup> Radio-elements was the term used for radioactives substances that we now call isotopes.

<sup>496</sup> Elliott Quincy Adams, “A Modification of the Periodic Table,” *Journal of the American Chemical Society* 33 (1911): 686, doi:10.1021/ja02218a004.

families.”<sup>497</sup> He placed these groups at the bottom of the table, the rare earths on the left-hand side and the radio-elements on the right. Adams did not claim there was a relationship between the rare earths and the radio-elements; they were simply the elements that did not fit into the other families.

Because the radio-elements had similar atomic weights, the question of placing more than one element in the same place in the periodic table was raised. The table Alexander T. Cameron published in 1909 is an example of those that moved away from what he referred to as the “restriction” of having only one element in each space (Fig. 3).<sup>498</sup> In his table, the radio-elements were not placed strictly according to atomic weight. For example, radium, radium emanation, and thorium emanation were all placed in the same space despite their differences in atomic weight because “they resemble each other so closely that it is legitimate to suppose that they occupy the same space.”<sup>499</sup>

									H 1
He 4	Li 7	Be 9	B 11	C 12	N 14	O 16	F 19		
Ne 20	Na 23	Mg 24	Al 27	Si 28	P 31	S 32	Cl 35.5		
Ar 40	K 39	Ca 40	Sc 44	Ti 48	V 51	Cr 52	Mn 55	Fe 56	Co 59
		Cu 64	Zn 65	Ga 70	Ge 72	As 75	Se 79	Br 80	
Kr 83	Rb 85.5	Sr 88	Y 89	Zr 90	Ch 93.5	Mo 96	Np? 100?	Ru 102	Rh 103
		Ag 108	Cd 112	Am 115	Sn 119	Sb 120	Te 127.5	I 127	
X 131	Cs 133	Ba 137	La 139	Ce, &c. 140-178	Ta 181	W 181		Os 191	Ir 193
		Au 197	Hg 202	Tl 204	Pb 207	Bi 208	? ← Act C ← Th C	← Act B ← A ← Th B ← A	Pt 195
← Act Em ← Th Em	← Act X ← Th X	← Radio-Act ← Radio-Th	← Act ← Mesoth. 2 ← 1 ←	Th 232.5 Ur X	← Radio-Ur ?				
← Ra Em		← Ra 226.5	← Ionium						

Figure 4.3: Cameron's 1909 Table

<sup>497</sup> Adams, “Modification,” 688.

<sup>498</sup> A. T. Cameron, “The Position of the Radio-active Elements in the Periodic Table,” *Nature* 82 (1909): 68, doi:10.1038/082067c0.

<sup>499</sup> Cameron, “Position,” 68.

Another reason for not paying strict heed to atomic weight when placing the radio-elements into the periodic table was the fact that it was not easy to determine their atomic weights. It had been theorized that alpha particles, one of the types of rays emitted by radioactive substances, were in essence helium atoms and Rutherford was able to prove that experimentally “in a most complete manner.”<sup>500</sup> Once that was established, it became possible to calculate the atomic weight of all radio-elements that were the result of an alpha particle emission. As helium has an atomic weight of four, the emission of an alpha particle was simply the loss of four units of atomic weight. For example, radium emits an alpha particle to decay into radium emanation,  $226.4 - 4 = 222.4$ , thus the atomic weight of radium emanation would be 222.4. Of course, this arithmetic could only be used in the case of alpha particle emission, not beta or gamma emissions. There was still some guess work involved, making Cameron’s decision to place radio-elements that closely resembled each other in the same space, despite any differences in atomic weight, more understandable.

Attempts to place the radio-elements in the periodic table and the discovery that alpha particles were helium atoms, led to a generalization that guided the placement of these elements into the table. This generalization became known as the displacement laws, or group displacement laws. Between 1911 and 1913, five

---

<sup>500</sup> Frederick Soddy, “Radioactivity,” *Annual Reports on the Progress of Chemistry* 6 (1909): 235, doi:10.1039/AR9090600232. For an overview of the evidence for this, see Soddy, “Radioactivity,” (1909): 232-238.

chemists – Frederick Soddy, Kasimir Fajans,<sup>501</sup> George von Hevesy,<sup>502</sup> Alexander S. Russell, and Alexander Fleck – contributed to the formation of the displacement laws.<sup>503</sup> As a radio-element emits a particle, its product moves either two places to the left in the periodic table in the case of an alpha-particle emission or one place to the right in the case of a beta-particle emission. Radium is located in Group II and when it emits an alpha particle its product is radium emanation, which is located in Group 0. Actinium, located in Group III, emits a beta particle resulting in radio-actinium, which is located in Group IV.<sup>504</sup>

The group displacement laws situated all of the radio-elements in the periodic table. And much as the periodic law had done, they also paved the way for the discovery of new radio-elements. It had been theorized that there were some gaps in the disintegration series. Almost immediately after publication of the displacement laws, radioactivists used those laws to figure out what was missing and to experimentally find the missing radio-elements. One of these predicted radio-elements, a product of Uranium X, was quickly discovered by Fajans and Beer and confirmed by Fleck; this predicted radio-element was called Uranium X<sub>2</sub> and

---

<sup>501</sup> Kasimir Fajans was a Polish chemist who spent time at Rutherford's lab in Manchester. Among other things, he co-discovered the element protactinium as well as the group displacement laws.

<sup>502</sup> George von Hevesy was a Hungarian chemist who also spent time at Rutherford's lab in Manchester. He co-discovered the element hafnium and won the Nobel Prize in 1943 for his work on the application of radioactive isotopes as tracers in the study of chemical and biological processes.

<sup>503</sup> See Soddy, *Chemistry, Part II*, 2-4; and K. Fajans, *Radioactivity and the Latest Developments in the Study of the Chemical Elements*, trans. from the 4<sup>th</sup> German ed. by T. S. Wheeler and W. G. King (London: Methuen & Co. Ltd., 1923), chapter 3, particularly note 21.

<sup>504</sup> Despite the many different forms of the periodic table that were in use, groups and their numbers were generally consistent.

was a child of Uranium X<sub>1</sub>.<sup>505</sup> The displacement laws were also put to work to solve the mystery of the parent element of actinium, which Soddy referred to as a “question ... of very great interest.”<sup>506</sup> However, it would be several years before it was discovered that Uranium X<sub>2</sub> was an isotope of the element 91, discovered in 1917, and more years before it was discovered to be the parent of actinium.<sup>507</sup> In some ways the development and use of the displacement laws was the weathering of another test, much like the accommodation of the inert gases within the table.

However, the displacement laws also created some doubts about the periodic system and the very nature of the elements themselves. Soddy noted that “almost every vacant place in the Periodic Table between thallium and uranium is crowded with non-separable elements of atomic weight varying over several units.”<sup>508</sup> Furthermore, the atomic weight of an element was not “a real constant, but a mean value, of much less fundamental interest than has been hitherto supposed.”<sup>509</sup> If atomic weight was no longer the identifying characteristic of an element, then

---

<sup>505</sup> Frederick Soddy, “The Radio-Elements and the Periodic Law,” *Report of the Eighty-Third Meeting of the British Association for the Advancement of Science, Birmingham: 1913* (London: John Murray, 1914): 447, <https://biodiversitylibrary.org/page/30382318>.

<sup>506</sup> Frederick Soddy, “The Origin of Actinium,” *Nature* 91 (1913): 634, doi:10.1038/091634a0.

<sup>507</sup> Element 91 was subsequently given the name protactinium in acknowledgement of its relationship to actinium. Aristid V. Grosse, “Element 91,” *Science*, n.s., 80 (1934): 512-516, <http://www.jstor.org/stable/1660876>.

<sup>508</sup> Frederick Soddy, “The Radio-Elements and the Periodic Law,” *Chemical News* 107 (1913): 99,

<https://hdl.handle.net/2027/mdp.39015073139282?urlappend=%3Bseq=103>.

<sup>509</sup> Soddy, “Radio-Elements,” *BA Report*, 447.



something had to take its place. Chemists probably felt some foreboding when Soddy announced, "The chemical analysis of matter is thus not an ultimate one."<sup>510</sup>

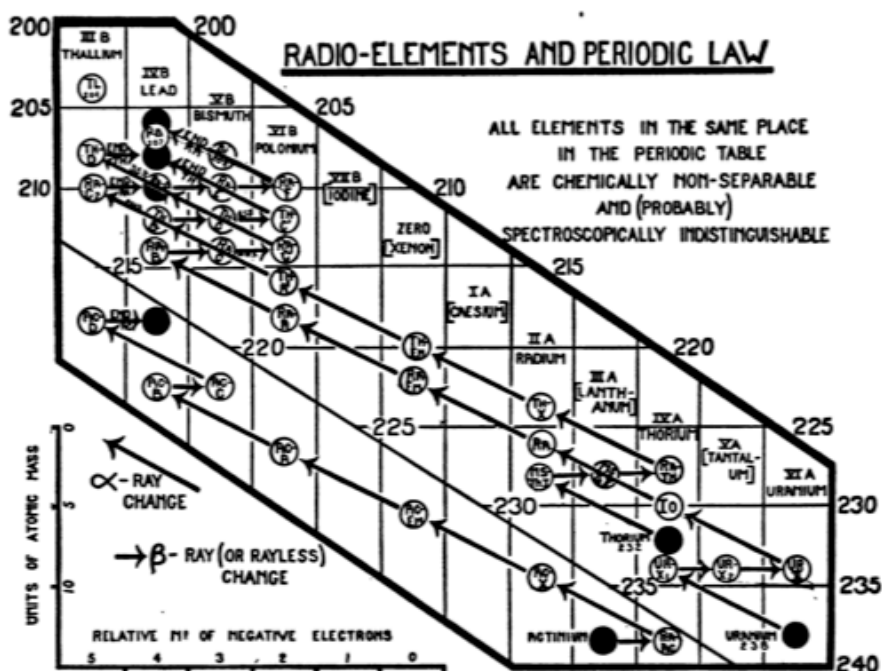

Figure 4.4: Radioelements in the Periodic System

Several years before the discovery of the displacement laws, Soddy had begun to realize that groups of radio-elements that possessed identical chemical characteristics were something other than different elements, despite their differing atomic weights. With the displacement laws, these groups of elements were now placed in the same place in periodic table (Fig. 4).<sup>511</sup> This suggested that these radio-elements were in fact the same element. Systematic study of the known radio-elements revealed that not only were the radio-elements which shared a space in the periodic table chemically identical, they were also largely physically identical.

<sup>510</sup> Soddy, "Radio-Elements," *BA Report*, 447.

<sup>511</sup> Soddy, *Chemistry, Part II*, 3.

Soddy called these nearly identical elements isotopes. Because these elements were chemically indistinguishable, “the experimental means capable of distinguishing and separating isotopes are very limited.”<sup>512</sup>

The concept of isotopy, the group displacement laws, and the disintegration theory may have alarmed some chemists. But for many these ideas weren't too radical. As Soddy had said, the *facts* of radioactivity were revolutionary, but the laws behind it were not. Those chemists who subscribed to – or were at least familiar with – late nineteenth century theories of the evolution of the elements were well placed to accommodate radioactivity into their framework. These theories, with their suggestions that elements were built from at least one if not more usually light elements, had in many ways laid the groundwork for the idea that elements disintegrate into other elements. The evolution of the elements had not been experimentally proven, but radioactivity had been. And if elements were proven to devolve, then it could perhaps be taken as evidence that elements evolved.

Concepts of the evolution of the elements were tied to Prout's hypothesis. The electron and the rays emitted by radioactive atoms, especially the alpha particle that Rutherford had shown to be the equivalent of a helium atom, made it clear that atoms were not indivisible but made of smaller particles. Prout had theorized that the elements were all composed of hydrogen atoms. If all atoms had electrons (it was not yet clear if all atoms contained other particles), then couldn't it be said that

---

<sup>512</sup> Frederick Soddy, “Radioactivity,” *Annual Reports on the Progress of Chemistry* 10 (1913): 265, doi:10.1039/AR9131000262. A summary of the experimental work can be found on pages 262-265.

there was a primary matter after all? It might not be hydrogen, as Prout had stated, but rather an even smaller part, such as the electron.<sup>513</sup> In 1904, the chemist Ida Freund wrote: “The primary matter ... has been shifted down the scale, and hydrogen itself appears as a highly condensed form of matter with each of its atoms containing about 1000 of the truly elemental *corpuscles* (or electrons) of which there is one kind only.”<sup>514</sup> More research into radioactivity and the structure of the atom would be needed before this idea could be proven, or not proven, but it was an idea that was easily acceptable to many.<sup>515</sup>

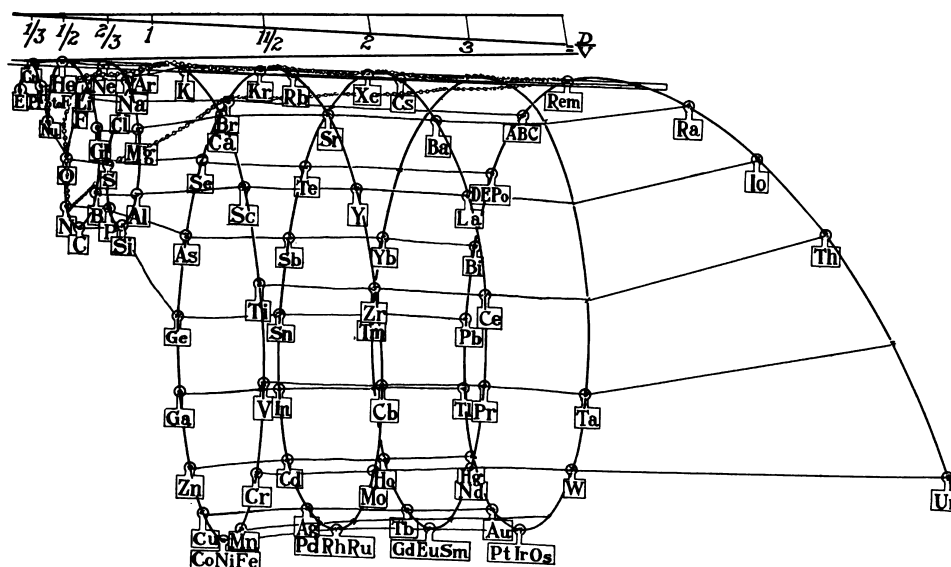

FIG. 11.—From a photograph of a model of the helix constructed for me by A. L. Kimball, Jr., and R. D. Eaglesfield.

### Figure 5.5: Emerson’s Helix Chemica

<sup>513</sup> In 1932, Soddy suggested that hydrogen could indeed be Prout’s primary matter as “it is the only element ... in the nucleus of which there are no constituent electrons.” See *The Interpretation of the Atom* (New York: G. P. Putnam’s Sons, 1932): 312.

<sup>514</sup> Ida Freund, *The Study of Chemical Composition: An Account of its Method and Historical Development* (Cambridge: Cambridge University Press, 1904) [New York: Dover Publications, Inc., 1968], 617.

<sup>515</sup> See W. H. Brock, *From Protyle to Proton: William Prout and the Nature of Matter, 1785-1985* (Bristol: Adam Hilger Ltd., 1985), chapter 8.

An example of the easy acceptance of these ideas is Benjamin Kendall Emerson, a professor of geology at Amherst College. He was well-versed in various representations of the periodic law, knowing of the work of Chancourtois, Crookes, Johnstone Stoney, and Thomas Carnelley, as well as that of Lothar Meyer and Mendeleev.<sup>516</sup> He stated that he had “long used a modification” of Crookes’s figure-of-eight in his geology course but he was led to devise a new form because of imperfections in Crookes’s spiral.<sup>517</sup> Emerson’s modification, the three-dimensional Helix Chemica, also incorporated current research in radioactivity (Fig. 5).<sup>518</sup> The helix was a series of circles and curves hanging from a rod. “At the origin of the curve,” Emerson wrote, “is ‘der Urstoff,’ the ‘Protyle’ of Bacon, the Ether or Electron E, with valence and density equal to zero.” He noted that while the evolution of the elements might not have been observed, “the opposite devolution is exemplified in the derivatives of radium.”<sup>519</sup> Emerson’s helix is notable as it combined earlier notions of a primary matter and the evolution of the elements with current ideas drawn from radioactivity.

---

<sup>516</sup> B. K. Emerson, “Helix Chemica: A Study of the Periodic Relations of the Elements and Their Graphic Representation,” *American Chemical Journal* 45 (1911): 160-210, <https://hdl.handle.net/2027/uva.x004036289?urlappend=%3Bseq=232>. An “abstract” of this lengthy article was published as “Concerning a New Arrangement of the Elements on a Helix, and the Relationships Which May Be Usefully Expressed Thereon,” *Science*, n.s., 34 (1911): 640-652, <http://www.jstor.org/stable/1638654>. Emerson “perfected” his model several years later; “The Helix Chemica,” *Chemical Reviews* 5 (1928): 215-229, doi:10.1021/cr60018a004.

<sup>517</sup> Emerson, “Helix Chemica,” (1911): 160.

<sup>518</sup> Emerson, “Helix Chemica,” (1911): Fig. II between pages 162 and 163.

<sup>519</sup> Emerson, “Helix Chemica,” (1911): 161.

## 1913 and All That

The discovery of the group displacements laws and the development of the concept of isotopy were just two of several discoveries in the year 1913 that would fundamentally change the underpinnings of the periodic system, while at the same time preserving it. Unlike these two discoveries, which were chemical in nature, the other important discoveries were physical. Since the discoveries of the electron as well as the numerous rays (e.g., x-rays,  $\beta$  rays) at the turn of the century, physicists had been learning more about the insides of atoms. The electron was joined by what Rutherford referred to as the nucleus of the atom.<sup>520</sup> In 1911, he proposed a model of the atom composed of a positively charged nucleus and negatively charged electrons. One unit of positive charge, Rutherford suggested, equaled two units of mass. The electrons occupied a shell, or ring, around the nucleus. The ratio of positively charged ions to negatively charged electrons determined the electrical charge of an atom.

In early 1913, Neils Bohr wrote to Hevesy that he was working on a new atomic model. The model would provide “a very suggestive indication of an understanding of the periodic system of the elements” as well as “a theory of chemical-combinations, a theory which permits to follow the process of combining of atoms in detail.”<sup>521</sup> Bohr had spent time in Rutherford’s lab and was quite

---

<sup>520</sup> E. Rutherford, “The Scattering of  $\alpha$  and  $\beta$  Particles by Matter and the Structure of the Atom,” *Philosophical Magazine*. 6<sup>th</sup> ser., 21 (1911): 669-688, <https://archive.org/details/londonedinburg6211911lond>.

<sup>521</sup> Niels Bohr to George von Hevesy, 7 February 1913, in *Niels Bohr: Collected Works*, L. Rosenfeld, ed. (Amsterdam: North-Holland Publishing Company, 1981), 2: 530.

familiar with Rutherford's atomic model. Bohr expanded on this model and explicitly tied it to the periodic system. Whereas Rutherford had proposed a single ring of electrons surrounding the nucleus, Bohr postulated several rings. He correlated the number of electrons in each ring with "the fact that the chemical properties of the elements of low atomic weight vary with a period of 8." Furthermore, the number of electrons in the outer ring, odd or even, was related "to the fact that the valency of an element of low atomic weight always is odd or even according as the number of the element in the periodic series is odd or even." Bohr was also able to relate the arrangement of electrons in the outer ring to atomic volume.<sup>522</sup> Atomic weight had long been seen by chemists as the most important characteristic of an element. For Bohr, however, nuclear charge was the most important aspect of an atom, not atomic weight.

Bohr's view was shared by some chemists, including Soddy. When Soddy described atomic weight as not being as fundamentally important as previously thought, he was referring in part to the nuclear charge of the atom. As far as the placement of the elements in the periodic table was concerned, nuclear charge was going to usurp the place of atomic weight. Much as chemists had done a century before, physicists began to notice a mathematical relationship between the atomic

---

<sup>522</sup> N. Bohr, "On the Constitution of Atoms and Molecules. Part II.- Systems Containing Only a Single Nucleus," *Philosophical Magazine*, 6<sup>th</sup> ser., 26 (1913): 495, 496, <https://archive.org/details/londonedinburg6261913lond>. This is the second of a trilogy of papers Bohr published on the constitution of the atom in 1913; see also *Philosophical Magazine*, 6<sup>th</sup> ser., 26 (1913): 1-25, 857-875. For more on the development of Bohr's atomic model, see Helge Kragh, *Niels Bohr and the Quantum Atom: The Bohr Model of Atomic Structure, 1913-1925* (Oxford: Oxford University Press, 2012).

weight of the elements and the nuclear charge of the atoms. In 1911, Antonius van den Broek, an amateur physicist, noted that when the elements were arranged by increasing atomic weight, their weights were equal to about twice their atomic charge.<sup>523</sup>

As more was learned about the radio-elements and the structure of the atom, van den Broek's idea of a relationship between atomic weight and atomic charge began to seem more likely. By 1913, van den Broek had concluded that an element's nuclear charge equaled its serial number within the periodic table; this serial number became known as the atomic number.<sup>524</sup> Soddy wrote that van den Broek's theory was "strongly supported by the recent generalisation [i.e., the group displacement laws] as to the radio-elements and the periodic law."<sup>525</sup> As far as Soddy was concerned, van den Broek's idea had been confirmed and was applicable to all of the elements, with the exception of the ever-difficult rare earths.

The rare earths elements had long posed problems for chemists. They were exceedingly difficult to separate and isolate and, as analytical techniques improved, it was often found that what had been thought to be an element was in fact a compound of two or more elements. They also were not easily accommodated into the periodic system. Van den Broek's theory showed great promise for ascertaining the place of the elements in the periodic table, including those pairs such as iodine

---

<sup>523</sup> A. van den Broek, "The Number of Possible Elements and Mendeléeff's 'Cubic' Periodic System," *Nature* 87 (1911): 78, doi:10.1038/087078b0.

<sup>524</sup> A. van den Broek, "Die Radioelemente, das periodische System und die Konstitution der Atome," *Physikalische Zeitschrift* 14 (1913): 32-41, <https://hdl.handle.net/2027/mdp.39015021268936?urlappend=%3Bseq=68>.

<sup>525</sup> Frederick Soddy, "Intra-atomic Charge," *Nature* 92 (1913): 399, doi:10.1038/092399c0.

and tellurium which had long seemed to be incorrectly ordered in Mendeleev's table. However, as Soddy had noted, van den Broek's theory also did not accommodate the rare earths. Bohr speculated that his atomic model would apply to the heavy rare earth elements, though he cautioned that the theory "is not sufficiently complete" to be sure.<sup>526</sup> It would take another physical discovery to make the rare earths somewhat easier to work with, if not to assist in placing them within the periodic table.

Chemists were no strangers to spectroscopy, having used variations of the technique for decades. In 1912, physicists discovered that when x-rays passed through crystals, it was possible to determine the wavelength associated with different substances due to the electric field produced by an atom's nuclear charge. This new form of spectroscopy was used by another Rutherford protégé, Henry Moseley. He wanted to test the atomic number theory of van den Broek as well as Bohr's atomic model and decided to attempt to determine the wavelengths of the elements. Moseley began with elements of lower atomic weight. He published the first of these x-ray spectra in 1913,<sup>527</sup> followed by the spectra of more elements in

---

<sup>526</sup> Bohr, "On the Constitution," 498. Bohr's 1913 atomic model was generally accurate only for very simple atoms, such as those of helium; the model was difficult to apply to the more complex atoms of heavier elements. J. W. Nicholson discussed some of the issues with Bohr's model in relation to van den Broek's hypothesis and Moseley's spectra work in "The High-Frequency Spectra of the Elements, and the Structure of the Atom," *Philosophical Magazine*, 6<sup>th</sup> ser., 27 (1914): 541-564, <https://archive.org/details/londonedinburg6271914lond>.

<sup>527</sup> H. G. J. Moseley, "The High-Frequency Spectra of the Elements," *Philosophical Magazine*, 6<sup>th</sup> ser., 26 (1913): 1024-1034, <https://archive.org/details/londonedinburg6261913lond>.



1914.<sup>528</sup> By this point, Moseley was confident enough in his results to write, “There is every reason to suppose that the integer which controls the X-ray spectrum is the same as the number of electrical units in the nucleus.” Thus his “experiments give the strongest possible support to the hypothesis of van den Broek.”<sup>529</sup>

Moseley then turned his attention to the rare earths. He was quite confident that “it will be possible to put every rare-earth element into its right pigeon-hole, to settle if any of them are really complex and where to look for them.”<sup>530</sup> Moseley also hoped to “weed out the superfluous [rare earths], as the subject is still in terrible confusion.”<sup>531</sup> However, the rare earths samples he had examined appeared to be full of impurities and he wrote to acquaintances in hopes of obtaining purer samples. Georges Urbain, a prominent French rare earths specialist, came to England bearing samples for Moseley. Urbain was particularly interested to see if Moseley could corroborate his claims for the discovery of a new element, celtium.<sup>532</sup> Although Moseley could not confirm his claim, Urbain was nonetheless

---

<sup>528</sup> H. G. J. Moseley, “The High-Frequency Spectra of the Elements. Part II,” *Philosophical Magazine*, 6<sup>th</sup> ser., 27 (1914): 703-713, <https://archive.org/details/londonedinburg6271914lond>.

<sup>529</sup> Moseley, “High-Frequency. Part II,” 712.

<sup>530</sup> Henry Moseley to Georg von Hevesy, 18 January 1914, in *H. G. J. Moseley*, 225.

<sup>531</sup> Henry Moseley to Ernest Rutherford, 4 March 1914, in *H. G. J. Moseley*, 229. As often happened in the case of the rare earths, there were rival claims for new elements. Georges Urbain and Carl Auer von Welsbach both claimed they had split the element ytterbia; the International Committee on Atomic Weights accepted Urbain’s claim over that of Auer von Welsbach. Each then went on to discover another new element, although in this instance the International Committee declined to accept Urbain’s celtium as a new element, largely because he had been unable to determine its atomic weight. See *H. G. J. Moseley*, 93-95 for a brief overview.

<sup>532</sup> See P. M. Heimann, “Moseley and Celtium: The Search for a Missing Element,” *Annals of Science* 23 (1967): 249-260.

“flabbergasted”<sup>533</sup> by the ease of Moseley’s technique, particularly in comparison with the many months, if not years, of tedious fractionations required to separate the various substances in a rare earths sample.<sup>534</sup>

Flabbergasted or not, Urbain was definitely impressed with Moseley and his work on the x-ray spectra of the elements. After his return to France, he wrote to Moseley regarding what he had dubbed Moseley’s law. This law, he said, provided a basis for Mendeleev’s classification of the elements.<sup>535</sup> If Moseley was correct, then van den Broek’s atomic number replaced atomic weight as the basis of the periodic law. In his textbook on radioactivity, Fajans wrote: “At first sight these conclusions would appear to depreciate the value of the periodic table, but the real significance of the table still remains, if, instead of the atomic weight, another property of the element – the atomic number – is taken as the foundation.”<sup>536</sup> Chemists’ empirical knowledge, gained from extensive and long-term experience, was being given robust theoretical explanations by physicists.

---

<sup>533</sup> “Flabbergasted” is the term used by historian John Heilbron; *H. G. J. Moseley*, 101.

<sup>534</sup> Moseley read a paper on his work with the rare earths at the 1914 British Association meeting in Australia. He intended to write an abstract of this paper for publication in the *Philosophical Magazine* “as to chemists the reality and order of the rare earth elements is of much importance.” However, Moseley was killed during World War I and the abstract was never written. H. G. J. Moseley, “High-Frequency Spectra,” *Report of the Eighty-Fourth Meeting of the British Association for the Advancement of Science, Australia, 1914* (London: John Murray, 1915), 305, <https://biodiversitylibrary.org/page/30399800>; only the title is listed in the BA Report. Henry Moseley to Ernest Rutherford, 4 April 1915, in *H. G. J. Moseley*, 267.

<sup>535</sup> Georges Urbain to Henry Moseley, 29 June 1914, in *H. G. J. Moseley*, 242. Urbain was quite enthusiastic about his visit to Moseley, at one point writing “Vive la loi de Moseley!”

<sup>536</sup> Fajans, *Radioactivity*, 67.

The discoveries of 1913 were generally accepted, at least by radioactivists. A. S. Eve, in a review of current atomic theories, concluded that, "All of these [physical] results are in harmony with the wonderful advances in radio-chemistry due to Soddy, Fajans, Von Hevesy and others."<sup>537</sup> Urbain, of course, was enthusiastic, at least about Moseley's spectra work. A joint discussion held by the physics and chemistry sections on the structure of atoms and molecules at the 1914 British Association meeting, however, revealed that not all chemists were convinced.<sup>538</sup> Armstrong, who was predisposed to reject anything physicists had to say about atoms and elements, voiced his thoughts on these new theories:

the arguments used are so novel and daring, the contentions so original, that at present they [chemists] are not in a position to appreciate, still less to criticise them effectively; in fact, the chemist's office at the moment must be mainly to point out the conditions that a theory must satisfy to meet his requirements.<sup>539</sup>

Armstrong went on to express his doubts about Soddy's concept of isotopy, Moseley's spectra work, Bohr's atomic model, and even radioactivity itself. "It is not to be supposed," he said, "that [the problems of atomic structure] are no longer amenable to chemical treatment and that they are ripe for purely physical treatment."<sup>540</sup> Further experiments of both a chemical as well as a physical nature, however, would be slowed by the advent of World War I. Although some work

---

<sup>537</sup> A. S. Eve, "Modern Views on the Constitution of the Atom," *Science*, n.s., 40 (1914): 120, <http://www.jstor.org/stable/1638909>.

<sup>538</sup> "Discussion on the Structure of Atoms and Molecules," *Report of the Eighty-Fourth Meeting of the British Association for the Advancement of Science, Australia, 1914* (London: John Murray, 1915), 293-301, <https://biodiversitylibrary.org/page/30399786>.

<sup>539</sup> "Discussion on the Structure," 294.

<sup>540</sup> "Discussion on the Structure," 296.

continued, the attention of many scientists in Europe and America turned toward the war.

### **Not the Place for Variety: The Periodic System for Pedagogical Purposes**

In an address before the American Chemical Society in 1911, Harry C. Jones addressed a fundamental question in teaching: “Whenever any great advance has been made in any branch of science, how early should this be incorporated in the teaching of that science; in a word, how closely should teaching follow research.”<sup>541</sup> Jones was of the opinion that “*truth* is even more important than *simplicity*.”<sup>542</sup> He argued that students who are provided with simple explanations will only ask questions requiring more complex, and more truthful, answers. Further, Jones asked, “shall we have two chemistries or one?”<sup>543</sup> A research chemistry that constantly advances and a teaching chemistry that ignores those advances was not in the best interests of science.

Despite the advocacy of Jones, chemistry textbooks were slow to incorporate radioactivity. Textbook authors generally choose to include new discoveries and theories only after they have been tested and accepted by the scientific community. It is also not too surprising given the fact that the scientific understanding of radioactivity changed quickly and frequently due to the fast-paced nature of its discoveries. As late as 1917, Francis P. Venable published *A Brief Account of Radio-Activity* for the purpose of filling a gap left in most chemistry textbooks which only

---

<sup>541</sup> Harry C. Jones, “The Introduction of Physical Chemical Conceptions in the Early Stages of the Teaching of Chemistry,” *Science*, n.s., 35 (1912): 87-88, <http://www.jstor.org/stable/1637415>.

<sup>542</sup> Jones, “Introduction,” 92.

<sup>543</sup> Jones, “Introduction,” 94.

included a “page or two” about radioactivity that he felt were “too condensed in their treatment to afford any intelligible grasp of the subject.”<sup>544</sup>

A page or two on the subject of radioactivity was, in fact, the most common treatment of the subject, when it was discussed at all. The new radioactive elements, such as radium and polonium, were also rarely discussed. Often the only mention of radioactivity was made in conjunction with the mention of radioelements. Robert Hart Bradbury’s 1903 *Elementary Chemistry*, for example, discussed radioactivity only in the section on the element uranium and did not use the word “radioactivity” at all.<sup>545</sup> In the second English edition of Walter Nernst’s *Theoretical Chemistry*, radioactivity, again without using the word itself, was a part of the section on free electrons.<sup>546</sup> By the 1909 edition of his *Descriptive Chemistry*, Lyman C. Newell had included a brief, almost one page, section on radium and radioactivity.<sup>547</sup> Also by 1909, G. S. Newth’s *A Text-book of Inorganic Chemistry* included an extensive discussion of radium and the radioelements, albeit in an appendix.<sup>548</sup>

---

<sup>544</sup> Francis P. Venable, *A Brief Account of Radio-activity* (Boston: D. C. Heath & Co., Publishers, 1917), iii <https://archive.org/details/ost-chemistry-briefaccountofra00venarich>.

<sup>545</sup> Robert Hart Bradbury, *Elementary Chemistry* (New York: D. Appleton and Company, 1903), 232-233, <https://books.google.com/books?vid=HARVARD:32044097019558>.

<sup>546</sup> Walter Nernst, *Theoretical Chemistry From the Standpoint of Avogadro’s Rule & Thermodynamics*, 2<sup>nd</sup> English ed., revised in accordance with the 4<sup>th</sup> German ed. (London: Macmillan and Co., Limited, 1904), 392-394, [https://hdl.handle.net/2027/uc1.\\$b35677](https://hdl.handle.net/2027/uc1.$b35677).

<sup>547</sup> Lyman C. Newell, *Descriptive Chemistry*, revised ed. (Boston: D. C. Heath & Co., Publishers, 1909), 372, <https://books.google.com/books?vid=HARVARD:32044097019756>.

<sup>548</sup> G. S. Newth, *A Text-book of Inorganic Chemistry*, new ed. (London: Longmans, Green and Co., 1909), 697-703, <https://hdl.handle.net/2027/uc1.b4059214>.

The inclusion of radioactivity in a chemistry textbook did not necessarily accompany the inclusion of radium, or other newly discovered radioelements, on any periodic tables used in the text. Even after radium was accepted by the International Committee on Atomic Weights and included on their table from 1903, radium rarely appeared on textbook periodic tables. Newth's 1909 text, for example, which included a lengthy discussion of radioactive elements did not include radium on the periodic table.<sup>549</sup> Ira Remsen did not include radium on the periodic tables his textbooks until 1909; the only table in *An Introduction to the Study of Chemistry* includes radium<sup>550</sup> while only one of the three tables in *A College Text-book of Chemistry* contains radium.<sup>551</sup>

Textbook authors could be slow to incorporate changes but some also embraced new concepts, often at the same time. George Senter, who was praised for having "one of the rarest and most precious gifts in a man of science – the gift of lucid explanation," was a physical chemist and the author of several well-known textbooks.<sup>552</sup> There were five editions of his *Text-Book of Inorganic Chemistry* over the course of the 1910s. Unlike many contemporary textbooks, the first edition, published in 1911, included a chapter on radioactivity and included radium on the

---

<sup>549</sup> Newth, *Text-book*, 118.

<sup>550</sup> Ira Remsen, *An Introduction to the Study of Chemistry*, 8<sup>th</sup> ed., revised and enlarged (New York: Henry Holt and Company, 1909), 263, <https://hdl.handle.net/2027/mdp.39015064485876>.

<sup>551</sup> Ira Remsen, *A College Text-book of Chemistry*, 2<sup>nd</sup> ed., revised (New York: Henry Holt and Company, 1909), 188, 189, 191, <https://books.google.com/books?vid=HARVARD:HW3ERO>.

<sup>552</sup> W. Wardlaw, "Dr. George Senter," *Nature* 149 (1942): 405, doi:10.1038/149405a0.

periodic table.<sup>553</sup> In each succeeding edition, the chapter on radioactivity increased to reflect the latest findings. However, by the time of the fifth edition, published in 1919, the periodic table included in the text was still arranged according to atomic weight and there was no mention of the concept of atomic number.<sup>554</sup>

Although radium and atomic number may not have been included on the periodic tables in all chemistry textbooks, the majority of textbooks did feature periodic tables. This was a change from Venable's lament in 1896 that "the old alphabetical lists" of the elements "have been hard to displace."<sup>555</sup> In fact, many chemists regarded periodicity to be one of the most interesting things about their science. In a posthumous paper published in 1907, James Monckman, who had worked as an assistant to J. J. Thomson, declared the periodic law to be "[o]ne of the most interesting things in the whole course of chemistry."<sup>556</sup> A year later, George Woodiwiss described periodicity as "one of the most interesting studies in chemistry."<sup>557</sup>

---

<sup>553</sup> George Senter, *A Text-Book of Inorganic Chemistry*, (London: Methuen & Co. Ltd., 1911), <https://hdl.handle.net/2027/nyp.33433090731435>.

<sup>554</sup> George Senter, *A Text-Book of Inorganic Chemistry*, 5<sup>th</sup> ed. (London: Methuen & Co. Ltd., 1919), [https://hdl.handle.net/2027/uc1.\\$b277864](https://hdl.handle.net/2027/uc1.$b277864).

<sup>555</sup> F. P. Venable, *The Development of the Periodic Law* (Easton, Pa.: Chemical Publishing Co., 1896), 124, <https://books.google.com/books?id=tF0vAQAAMAAJ>.

<sup>556</sup> James Monckman, "On a Natural System of Arranging the Chemical Elements, In Which They Fall Into the Periodic Groups, Based Solely Upon the Atomic Volumes and the Combining Weights," *Chemical News* 95 (1907): 5, <https://hdl.handle.net/2027/mdp.39015073138953?urlappend=%3Bseq=21>. Monckman died in 1905; a brief obituary can be found in "Notes," *Nature* 73 (1905): 106, doi:10.1038/073105b0.

<sup>557</sup> Geo. Woodiwiss, "Some of the Non-metallic Elements in Connection with Valency and Specific Gravity," *Chemical News* 97 (1908): 265, <https://hdl.handle.net/2027/njp.32101075379873?urlappend=%3Bseq=275>.

Despite this interest in periodicity, or perhaps because of it, there was no consistency in the discussion of it in textbooks. Woodiwiss bemoaned the fact that “[t]he average student ... fails to appreciate the full importance of periodicity, and passes it by as a mere curiosity.” This occurred because of “different writers giving different versions” of the order of the elements within the periods.<sup>558</sup> Monckman likewise noted that there was “so much confusion” as “it is easy to read half-a-dozen arrangements of the elements in as many different books on the subject.” He admonished: “Now while variety is pleasing in art and decoration, it cannot by any means be considered so here, and therefore a method at once simple and effective, that will get rid of this confusion, should be welcomed.”<sup>559</sup> Of course, Monckman’s and Woodiwiss’s solution to ending the confusion was to submit proposals for their own systems.

There was good reason for the confusion to be found in textbooks. As Venable wrote in 1896, “The systematic arrangements of Mendeléeff or Meyer or Bayley are all necessarily tentative because of the serious imperfections in our knowledge.”<sup>560</sup> This view was echoed by Armstrong in 1900. “Even in the form in which it was put forward by Mendeleeff,” he stated, “the periodic generalisation is but a first approximation: and the great Russian has himself pointed out that it needs improvement and development.”<sup>561</sup> In his annual report on inorganic

---

<sup>558</sup> Woodiwiss, “Some of the Non-metallic,” 265.

<sup>559</sup> Monckman, “On a Natural System,” 5.

<sup>560</sup> F. P. Venable, “Some Difficulties in the Presentation of the Periodic Law,” *Science*, n.s., 4 (1896): 160, <http://www.jstor.org/stable/1622770>.

<sup>561</sup> Henry E. Armstrong, “The Classification of the Elements,” *Proceedings of the Royal Society of London* 70 (1902): 86, <http://www.jstor.org/stable/116601>.



chemistry for 1908, Hugh Marshall stated that “Mendeléeff's original arrangement is not altogether a happy one; although the arrangement may occasionally serve for a rough classification ... its use nowadays is hardly justifiable.”<sup>562</sup>

Although Marshall may have considered the use of Mendeleev's table to be “hardly justifiable,” the basic periodic table forms used for pedagogical purposes during the early years of the twentieth century changed little from those used in the late nineteenth century. Versions of Mendeleev's short-form table remained highly popular. Lothar Meyer's atomic volume curve was also popular, especially as it was a form well-suited to illustrating relationships between atomic weight and other properties. Many textbooks chose to include both of these forms rather than just one of them. For example, J. I. D. Hinds<sup>563</sup> and R. M. Caven and G. D. Lander<sup>564</sup> used a short-form table to illustrate the discussion of the classification of the elements and an atomic volume curve in the discussion of atomic volume, while A. Reychler<sup>565</sup> used both in discussing valency and periodicity.

Other textbooks contained multiple periodic tables. One notable example is Joel H. Hildebrand's *Principles of Chemistry*, originally designed for use in his course in General Chemistry and Qualitative Analysis at the University of California,

---

<sup>562</sup> Hugh Marshall, “Inorganic Chemistry,” *Annual Reports on the Progress of Chemistry* 5 (1908), 70-71, doi:10.1039/AR9080500031.

<sup>563</sup> J. I. D. Hinds, *Inorganic Chemistry, with Elements of Physical and Theoretical Chemistry*, 1<sup>st</sup> ed. (New York: John Wiley & Sons, 1902), 66-71, <https://books.google.com/books?vid=HARVARD:32044091927608>.

<sup>564</sup> R. M. Caven and G. D. Lander, *Systematic Inorganic Chemistry, From the Standpoint of the Periodic Law: A Textbook for Advanced Students*, New ed. (London: Blackie and Son Limited, 1911), 28-34, <https://hdl.handle.net/2027/nyp.33433090729660>.

<sup>565</sup> A. Reychler, *Les théories physico-chimiques*, 3<sup>rd</sup> ed. (Bruxelles: H. Lamertin, 1903), 43-51, <https://books.google.com/books?id=k1wvAQAAMAAJ>.

Berkeley. Both the Preliminary edition of 1917 and the first edition of 1918 contained four versions of the periodic table: Lothar Meyer's atomic volume curve, a Mendeleev short-form table, Julius Thomsen's table, and Soddy's figure-of-eight.<sup>566</sup> Hildebrand noted that "[t]he periodic classification of the elements is exceedingly useful," but that there were "certain defects in the Mendeléeff table."<sup>567</sup> The other representations were given to illustrate how those defects could be better dealt with in other forms.

H																	He																				
1.008																	4																				
Li											Be	B	C	N	O	F	Ne																				
7.03											9.1	11	12	14.04	16.00	19	20																				
Na											Mg	Al	Si	P	S	Cl	A																				
23.05											24.36	27.1	28.4	31.0	32.06	35.45	39.9																				
K	Ca											Sc	Ti	V	Cr	Mn	Fe	Co	Ni	Cu	Zn	Ga	Ge	As	Se	Br	Kr										
39.10	40.1											44.1	48.1	51.2	52.1	55.0	55.9	59.0	58.7	63.6	65.4	70	72	75.0	79.1	79.96	81.12										
Rb	Sr											Y	Zr	Nb	Mo		Ru	Rh	Pd	Ag	Cd	In	Sn	Sb	Te	J	X										
85.4	87.6											89.0	90.7	94	96.0		101.7	103.0	106	107.93	112.4	114	118.5	120	127.6	126.95	128										
Cs	Ba	La	Ce	Nd	Pr		Sa	Eu	Gd	Tb	Ho	Er	Tu	Yb		Ta	W		Os	Ir	Pt	Au	Hg	Tl	Pb	Bi											
133	137.4	139	140	143.6	140.5		150.3	151.79	156	160	162	166	171	173.0		183	184		191	193.0	191.8	197.2	200.3	204.1	206.9	208.5											
Ra	La	Th											U											Ac											Pb	Bi	Te
226		232											238.5																								

**Figure 4.6: Werner's 1905 Table**

Marshall had noted that many of the difficulties of the short-form table "can be avoided by the use of longer periods."<sup>568</sup> He was referring, in particular, to a new

<sup>566</sup> Joel H. Hildebrand, *Principles of Chemistry*, preliminary ed. (Berkeley: Lederer, Street & Zeus Co., Publishers, 1917), 136-142, [https://hdl.handle.net/2027/uc1.\\$b100552](https://hdl.handle.net/2027/uc1.$b100552); Joel H. Hildebrand, *Principles of Chemistry* (New York: The Macmillan Company, 1918), 251-259, [https://hdl.handle.net/2027/uc1.\\$b277972](https://hdl.handle.net/2027/uc1.$b277972).

<sup>567</sup> Hildebrand, *Principles of Chemistry* (1918), 255.

<sup>568</sup> Marshall, "Inorganic Chemistry," 71.

table published in 1905 by the Swiss chemist Alfred Werner (Fig. 6).<sup>569</sup> In an effort to better incorporate all of the rare earth elements, including those that had at the time been recently discovered, Werner created a long-form table.<sup>570</sup> The rare earth elements were moved into an area at the bottom of the table. This is similar to the place occupied by the lanthanides and actinides in the modern table, although in Werner's table they were still a part of the table rather than separated from it. Werner included this long-form table in his inorganic chemistry textbook.<sup>571</sup>

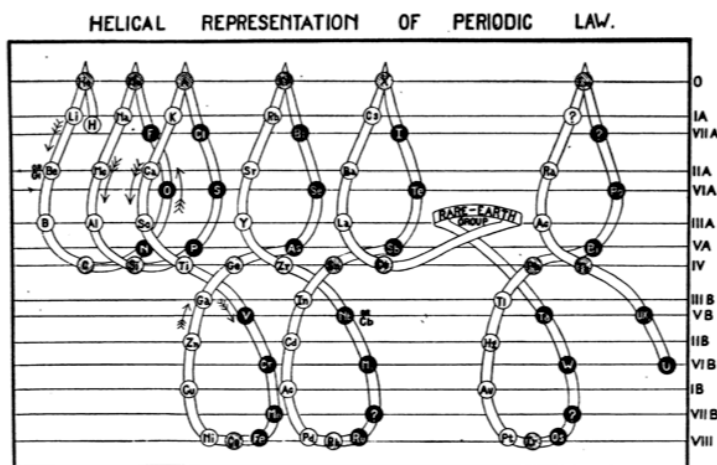

**Figure 4.7: Soddy's Figure of Eight**

<sup>569</sup> A. Werner, "Beitrag zum Ausbau des periodischen Systems," *Berichte der deutschen chemischen Gesellschaft* 38 (1905): 916,

<https://hdl.handle.net/2027/iau.31858002459455?urlappend=%3Bseq=922>.

<sup>570</sup> Werner was far from the only chemist to create a new periodic table to better incorporate the rare earths, even if it was by relegating them to a separate area of the table, but he was the first to create a long-form table for the purpose. See, for example, Heinrich Blitz, "Zur Kenntniss des Perioden-Systems der Elemente," *Berichte der Deutschen Chemischen Gesellschaft* 35 (1902): 562-568, <https://hdl.handle.net/2027/iau.31858002459349?urlappend=%3Bseq=566>; Armstrong, "Classification."

<sup>571</sup> A. Werner, *Neuere Anschauungen auf dem Gebiete der anorganischen Chemie* (Braunschweig: F. Vieweg und Sohn, 1905); English translation, *New Ideas on Inorganic Chemistry*, trans. from the 2<sup>nd</sup> German ed. by Edgar Percy Hedley (New York: Longmans, Green, and Co., 1911), <https://books.google.com/books?id=STe4AAAAIAAJ>. Subsequent editions continued to include the long-form table.

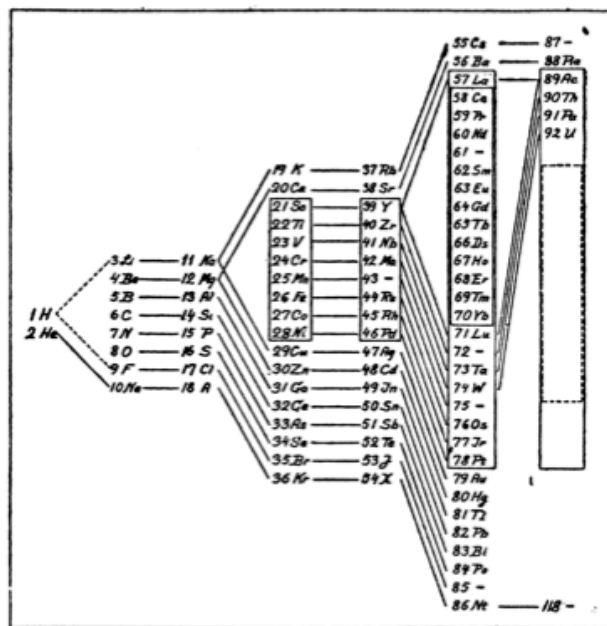

Figure 4.8: Bohr's Table

The new discoveries about the elements that were derived from research into radioactivity did little to change the forms of the periodic table which chemists found useful.<sup>572</sup> Alongside Mendeleev's short-form table and Meyer's atomic volume curve, other previously used forms were adapted to incorporate new information and new discoveries. Echoing a common complaint, Soddy referred to the short-form table as "very convenient" but also "misleading, in that it does not properly represent the continuity of arrangement" such as that shown by William Crookes's "figure of eight."<sup>573</sup> The table which Soddy created was an updated version of a "figure of eight," drawn in two dimensions but meant to be depicted in three

<sup>572</sup> Bernadette Bensaude-Vincent stated, "Neither the re-interpretation of periodicity in terms of atomic structure nor the discovery of radioelements implied a preference for the long rectangular chart so familiar today." See "Graphic Representations of the Periodic System," in *Tools and Modes of Representation in the Laboratory Sciences*, ed. U. Klein (Dordrecht: Kluwer Academic Publishers, 2001), 144.

<sup>573</sup> Soddy, *Chemistry, Part II*, 9.

dimensions<sup>574</sup> (Fig. 7).<sup>575</sup> Bohr also found fault with the short-form table. In discussing the structure of the atom and its relationship to the properties of the elements, he chose to use an updated version of the Thomsen-Bayley table (Fig. 8).<sup>576</sup> Bohr described this form as “more suited for comparison with theories of atomic constitution” than “usual representations of the periodic system.”<sup>577</sup>

Atomic number seemed to be one change that was very slow to be incorporated into the periodic tables used in textbooks. Most textbooks still used atomic weight at the organizing principle. Soddy’s “figure of eight” table had no atomic weights or atomic numbers, while the standard short form table he included had only atomic weights. The periodic table included in the 1914 edition of Harry Jones’ *Introduction to Physical Chemistry* was also arranged by atomic weight.<sup>578</sup> Bohr’s table, on the other hand, was organized by atomic number and did not include atomic weights at all. This reflected lingering disciplinary differences – chemists, even those who embraced radioactivity, were still attuned to atomic

---

<sup>574</sup> Soddy was not the only one to revise the figure-of-eight, while keeping more or less the same shape. Frank Austin Gooch and Claude Frederic Anderson presented a version of it in their textbook *Outlines of Inorganic Chemistry* (New York: The Macmillan Company, 1905), table between pages 8 and 9 in Part II, <https://books.google.com/books?vid=HARVARD:32044091983031>.

<sup>575</sup> Soddy, *Chemistry, Part II*, 11.

<sup>576</sup> Niels Bohr, *The Theory of Spectra and Atomic Constitution: Three Essays* (Cambridge: Cambridge University Press, 1922), 70. Bohr acknowledged Julius Thomsen but not Thomas Bayley. It is likely that Bohr was unaware of Bayley’s table as Venable pointed out that Thomsen had failed to acknowledge Bayley in his own 1895 publication. See F. P. Venable, “New Grouping of the Elements,” *Chemical News* 72 (1895): 126, <https://hdl.handle.net/2027/inu.30000088771047?urlappend=%3Bseq=464>.

<sup>577</sup> Bohr, *The Theory*, 69-70.

<sup>578</sup> Harry C. Jones, *Introduction to Physical Chemistry*, 2<sup>nd</sup> edition, revised (New York: The Macmillan Company, 1914), 13, <https://hdl.handle.net/2027/iau.31858047931062>.

weight whereas physicists, who did not have the same history, were more likely to make the switch to atomic number.

\*\*\*\*\*

As this chapter has shown, the periodic system served as an important research tool for those investigating radioactivity and the structure of the atom. Physicists as well as chemists utilized the periodic system in their work. In developing his model of the atom, Thomson used the periodicity elucidated by the periodic law to recognize the effect of atomic structure upon the properties of atoms. Similarly, Bohr correlated the number of electrons in each ring of his atomic model with the periodicity of chemical properties. The relationship between atomic weight and atomic charge led van den Broek to place the elements within the periodic table according to their atomic number. And Moseley set out to test Bohr's atomic model and van den Broek's atomic number theory, as well as his own new technique of x-ray spectroscopy, by sequentially testing the elements in the periodic table. The assistance of Mendeleev's periodic law was essential to many of the discoveries regarding the atom made at the turn of the century.

Perhaps taking Monckman's admonishment that "variety is pleasing in art and decoration" but not when it comes to the arrangement of the elements, the new discoveries seemed to have little impact on chemical pedagogy. The continuity that Soddy had seen was well-represented in the chemistry textbooks published before World War I, both in the changes and the lack of changes that were made in content. The inclusion of radioactivity and atomic structure in textbooks had little effect on the representations of the periodic system. In spite of its many perceived and

recognized deficiencies, Mendeleev's short form table was still prominently used. While there was an increase in the use of different forms of the table, many of these forms were updated versions of a previously used design rather than radically new forms. The periodic system may have been understood by researchers to be organized by the physical principle of atomic number, but that had little effect on the continued importance of atomic weight to the classification of the elements. Yet however it was represented, the periodic system remained fundamental to chemical pedagogy.

**CHAPTER 5**  
**“THE FINGER-POST OF CHEMICAL SCIENCE”:**  
**THE PERIODIC LAW IN THE ERA OF INTERNATIONAL STANDARDIZATION,**  
**1900-1923 AND BEYOND**

**Introduction**

The British chemist Thomas Carnelley was an early and ardent supporter of the periodic system, dedicating his own research to its development. In 1879, a mere decade after the initial publication of Mendeleev’s discovery, he enthusiastically prophesied:

The importance of the work of Newlands and Mendeljeff cannot be easily overrated. The principle proposed independently by each of them will serve in the future, and has done to some extent already, to indicate those directions in which research is most needed and in which there is most promise of interesting results. The application of this principle will also enable us to make predictions of phenomena still unknown, and will at the same time prevent many fruitless researches. It is and will be, in fact, for some time to come the finger-post of chemical science.<sup>579</sup>

The periodic system and the atomic weights that provided the means for the organization of the elements had indeed led to many new discoveries and great changes in chemistry by the time World War I began. Although Carnelley did not mention chemical education, the periodic system had also led to changes in the way chemical courses were taught and textbooks were organized. There were also a large variety of visual representations, many of which had been created for pedagogical reasons.

---

<sup>579</sup> Thomas Carnelley, “Influence of Atomic Weight,” *Philosophical Magazine*, 5<sup>th</sup> ser., 8 (1879): 305-306, [https://hdl.handle.net/2027/uc1.\\$b785880?urlappend=%3Bseq=319](https://hdl.handle.net/2027/uc1.$b785880?urlappend=%3Bseq=319).



The post-World War I era was one of great change with regards to the periodic table. The periodic table itself was now organized by atomic number – the number of protons found within the nucleus of one atom of an element – ideas which were “phenomena still unknown” when Carnelley was proselytizing Mendeleev’s work. Atomic weight, which had been the driving force behind much chemical research in the nineteenth century, was ceasing to be important – or as important – in the study of the elements. Radioactivity was an accepted fact. The concept of element itself was under consideration and would be redefined. With these changes, the periodic system had stabilized. It was no longer an important object of research itself<sup>580</sup> but rather a part of the chemist’s research toolkit, a part of the nineteenth century heritage “created amid controversy and polemics ... now ensconced in the routine.”<sup>581</sup>

While it may have slipped into comfortable familiarity for the researcher, the periodic table remained a lively and dynamic part of chemical education. It was so integral that at the end of the twentieth century, one popular chemistry textbook introduced it in the following way: “In a room where chemistry is taught or practiced, a chart called the periodic table is almost certain to be found hanging on

---

<sup>580</sup> This is not to say that the periodic system ceased to be an object of research. A recent book contains several essays by scientists seeking to explain the periodicity that underlays the periodic system, exploring different ways to group the elements within the table, and examining different forms of representation, as well as historical essays; see Eric Scerri and Guillermo Restrepo, eds., *Mendeleev to Oganesson: A Multidisciplinary Perspective on the Periodic Table* (New York: Oxford University Press, 2018).

<sup>581</sup> Bernadette Bensaude-Vincent, and Isabelle Stengers, *A History of Chemistry*, trans. by Deborah van Dam (Cambridge, MA: Harvard University Press, 1996), 207.

the wall.”<sup>582</sup> More than a hundred years after Carnelley touted the research importance of the periodic system, the periodic table was considered ubiquitous enough for chemistry textbook writers to assume that one would be hanging in every chemistry classroom. This chapter seeks to answer the question of how the periodic table came to be hanging in classrooms across the world by the middle of the twentieth century.

The first decades of the twentieth century heralded an era of internationalism in which scientists sought to standardize their fields of research. International congresses, committees, and organizations were formed for the purpose of creating standardized nomenclature, weights and measures, and equations, among other things. Such an integral tool of chemical research and education as the periodic table would have been an object of consideration for such groups. However, as this chapter shows, this was not the case. The official position of the International Union of Pure and Applied Chemistry (IUPAC), created in 1919, regarding the periodic table is: they are involved in establishing the criteria for the discovery of new elements, applying that criteria to discovery claims, naming new elements, defining the groups of elements and their names, and regularly reviewing the atomic weights of the elements.<sup>583</sup> Although the IUPAC encourages the use of the standard periodic table, “teachers and others should not hesitate to develop new forms of the periodic table, and to publish them if they so wish.” However, they are

---

<sup>582</sup> Steven S. Zumdahl, *Chemistry*, 4<sup>th</sup> ed. (Boston: Houghton Mifflin Company, 1997), 57.

<sup>583</sup> IUPAC, “Periodic Table of the Elements,” <https://iupac.org/what-we-do/periodic-table-of-elements/>.

not encouraged to ask the IUPAC for approval of such tables as “there is unlikely to be a definitive IUPAC-recommended form of the periodic table.”<sup>584</sup>

The periodic table appears to have resisted standardization – or even great changes – by international chemical organizations. Attempts by the IUPAC to make changes to the periodic table were met with cries of outrage – from chemical educators not from research chemists. It was chemical educators, with some assistance from commercial scientific supply companies, who were responsible for the consensus that the current standard form was the best form for pedagogical purposes. The standardized form developed during the first decades of the twentieth century and slowly became the commonly accepted form until, by the 1950s, it had replaced all others in chemistry textbooks. But although the standard table “reigns supreme,” it has not completely ousted other forms of the periodic table.

### **International Standards Before World War I**

In 1907, the soon-to-be governor of Connecticut, Simeon E. Baldwin, surveyed the rapid increase in number of international congresses and conferences from the nineteenth century into the first years of the twentieth century. The unofficial congresses, more so than official ones, he stated, brought together men on an even footing, at the behest of no master: “This unofficial set of men has discovered in our day that it has the advantage of numbers, and that in international gatherings called by no other authority than that of some of its members, it can

---

<sup>584</sup> G. Jeffery Leigh, “Periodic Tables and IUPAC,” *Chemistry International* 31.1 (2009): 6, doi:10.1515/ci.2009.31.1.4

exert no small influence towards preventing controversies, as well as towards ending them.”<sup>585</sup> One way to halt controversy was to create standards. Until the formation of international chemical organizations, which began in the years just prior to the start of World War I, international scientific congresses were the arena in which discussions about standards took place. As historian Debra Everett-Lane noted, the unification of scientific knowledge was one of the most important tasks. Participants at these international congresses “believed they should easily be able to agree upon the best theory, method, or resolution to a problem.”<sup>586</sup>

The Fourth International Congress of Applied Chemistry,<sup>587</sup> held in Paris in 1900, provides a look at how chemists attempted to end controversy by creating standards. Three main areas of debate, if not outright controversy, were discussed during the meetings held by Section I, the section on analytical chemistry. Oxygen was widely considered as the best basis for determining atomic weights – recall the vote in 1899 called by the proto International Atomic Weights Committee – but it was not the only basis being used. The Section unanimously agreed that the adoption of O=16 as the basis for atomic weights would “lead to a greater stability” and hoped that giving the International Committee its support would provide a

---

<sup>585</sup> Simeon E. Baldwin, “The International Congresses and Conferences of the Last Century as Forces Working Toward the Solidarity of the World,” *American Journal of International Law* 1 (1907): 573, <http://www.jstor.org/stable/2186820>.

<sup>586</sup> Debra Adrienne Everett-Lane, “International Scientific Congresses, 1878-1913: Community and Conflict in the Pursuit of Knowledge,” PhD dissertation, Columbia University, 2004: 7.

<sup>587</sup> For a brief history of the International Congresses of Applied Chemistry, see D. Thorburn Burns and H. Deelstra, “The Origins and Impact of the International Congresses of Applied Chemistry,” *Microchimica Acta* 172 (2011): 277-283, doi:10.1007/s00604-010-0465-3.

boost to the Committee's efforts.<sup>588</sup> They also debated the use of specific symbols and abbreviations, which varied across languages, and agreed that the setting of standards in these areas was necessary; they adopted, in principle, some of the recommendations made by the German chemical journal *Chemiker Zeitung*.<sup>589</sup> The Section also voted to form an international committee whose task would be to establish an international table of chemical and physical constants, the use of such table being obligatory by chemists in those countries represented at the Congress.<sup>590</sup>

Some problems were large enough to require a congress devoted solely to that topic. A group of 34 chemists met in Geneva in 1892 for the purpose of developing a standard nomenclature for organic chemistry. They left that congress having met only some of their objectives but they had developed the basis for a new nomenclature. Despite the agreements they made, they faced difficulties in implementing this system of names. There was an initial flurry of adoption as accounts of the congress and the rules of the new nomenclature were published. But a period of skepticism followed. Journal editors found the system frustrating as the names were awkward and often long, and the rules were complicated. The system was also potentially divisive as not all chemical compounds were covered.

---

<sup>588</sup> H. W. Wiley, "The Fourth International Congress of Applied Chemistry," *Journal of the American Chemical Society* 23 (1901): 184, doi:10.1021/ja02029a010; Henri Moissan and François Dupont, *IVe Congrès International de Chimie Appliquée: Compte Rendu In-Extenso* (Paris: L'Association des Chimistes de Sucre et de Distillerie, 1902): 1:40, <https://hdl.handle.net/2027/mdp.39015078144402>. For the entire discussion see: Moissan and Dupont, *IVe Congrès*, 1:35-40.

<sup>589</sup> Moissan and Dupont, *IVe Congrès*, 1:44-48; "Internationale Vereinbarungen in chemischen Grundfragen," *Chemiker Zeitung* 24 (1900): 281-282, <https://hdl.handle.net/2027/njp.32101050964954?urlappend=%3Bseq=305>.

<sup>590</sup> Moissan and Dupont, 1:55-57.

As their frustration grew, many of the journal editors stopped using the system.<sup>591</sup>  
This effectively ended the use of the new nomenclature by chemists.

This was a central issue regarding resolutions made at international congresses: how to enforce the adoption and use of standards. Although such standards were developed primarily by prominent scientists in a field, they were not necessarily adopted by all who worked in said field. Efforts to establish firm conventions typically failed to end controversy and confusion, the ostensible reason for establishing standards. This is because the use of standards is voluntary. There must be some incentive to follow a standard, whether it is to fit into a community or to avoid the risk of losing credibility and/or opportunities.<sup>592</sup> However, there was no real incentive to follow any decisions made at an international scientific congress. The analytical section of the Fourth International Congress voted to form international committees and to offer their support to already extant committees, evidence the members of the Congress realized they had little power to enforce their resolutions. Ultimately, it would take the creation of an international chemical association to make standards more or less enforceable.

The International Association of Chemical Societies (IACS) was organized in 1911 to bring together the many national chemical societies under the belief that “Union is strength.” The IACS proposed to develop standards in those same areas

---

<sup>591</sup> Evan Hepler-Smith, “‘Just as the Structural Formula Does’: Names, Diagrams, and the Structure of Organic Chemistry at the 1892 Geneva Nomenclature Congress,” *Ambix* 62 (2015): 26, doi:10.1179/1745823414Y.0000000006. Although the nomenclature developed in 1892 failed to be adopted, it did ultimately serve as the basis for the chemical nomenclature used today.

<sup>592</sup> Nils Brunsson and Bengt Jacobsson, *A World of Standards* (Oxford: Oxford University Press, 2000): chapter 9.

which were debated in the more informal international congresses: nomenclature and classification, atomic weights, unification of notation, and the indexing of chemical work and other journal and information related activities.<sup>593</sup> But unlike the *ad hoc* international congresses, there was an agreed upon method of dissemination of these standards: member associations agreed to publish their journals in accordance with the standards accepted by the IACS.<sup>594</sup> In doing so, they implied that these standards were approved by the national chemical societies. Thus, individual members of the societies would also accept those standards and use them in their own work.

The difficulties in the acceptance and use of standards are illustrated by the issue of atomic weights. The International Committee was formed in 1900 by representatives appointed by several of the national chemical societies. Despite a decisive vote by individual chemists in which they overwhelmingly chose O=16 rather than H=1 as the basis for determining atomic weights, the committee proceeded to publish its annual tables using both standards. In 1904, two members of the Tokyo Chemical Society wrote to protest this, as well as the use of dual names and symbols for the elements beryllium and niobium.<sup>595</sup> They argued that the use of both standards made the situation “worse than ever, for there are now two sets of atomic weights which are apparently equally authorised,” something which was

---

<sup>593</sup> William Ramsay, “The International Association of Chemical Societies,” *Nature* 92 (1913): 453-454, doi:10.1038/092453a0.

<sup>594</sup> “International Association of Chemical Societies,” *Journal of Industrial and Engineering Chemistry* 3 (1911): 614, doi:10.1021/ie50032a021.

<sup>595</sup> Joji Sakurai and K. Ikeda, “International Atomic Weights,” *Chemical News* 89 (1904): 305, <https://hdl.handle.net/2027/mdp.39015073139126?urlappend=%3Bseq=311>.

directly contrary to the decision to adopt O=16 as the standard. In response, Frank W. Clarke wrote that the committee did not endorse H=1 but was “simply recognis[ing] an existing demand” and did not feel they could “assume an agreement where no agreement exists.” As for the dual names and symbols, they were used in the American version of the table as “usage is divided ... here again no agreement exists.”<sup>596</sup> It is unclear why the committee felt there was no agreement regarding O=16 given the decisive vote in 1899. However, they obviously felt that they could not decide on one standard over the other, or one set of names and symbols over another, despite the support of the national chemical societies.

The International Committee on Atomic Weights remained an unmoored ship, taking instruction from multiple directions and making no firm decisions regarding standards. In their report for 1911, they noted a change in the publication date of their report, as the Chemical Society of London had voted for them to do so, with the French and American societies giving their agreement.<sup>597</sup> In 1912, a resolution was passed at the Eighth International Congress of Applied Chemistry “favoring less frequent changes in the official table of atomic weights” and that the table for 1913 should remain the official table until 1915. The committee

---

<sup>596</sup> F. W. Clarke, “International Atomic Weights,” *Chemical News* 90 (1904): 56, <https://hdl.handle.net/2027/mdp.39015073139126?urlappend=%3Bseq=388>.

<sup>597</sup> F. W. Clarke, T. E. Thorpe, W. Ostwald, and G. Urbain, “Annual Report of the International Committee on Atomic Weights, 1911,” *Journal of the American Chemical Society* 32 (1910): 1113-1116, doi:10.1021/ja01928a001.



complied.<sup>598</sup> The International Committee was clearly not an independent entity, if it found it necessary to follow the whims of the national societies.

At the third meeting of the IACS in 1914, “[s]tatutes were proposed for the affiliation of the International Committee on Atomic Weights,” with the committee continuing its work under the sponsorship of the IACS.<sup>599</sup> The expectation was that the annual report and table of atomic weights would be published in the journals of the chemical societies of all member nations. The committee’s report had been distributed to all national societies before this time, however, there had been no agreement in place that they would publish it. The International Committee may have found greater confidence to choose and set standards once it became affiliated with the IACS, a body that promised more power to enforce such standards.

However, World War I effectively spelled the end of the IACS.

### **The International Union of Pure and Applied Chemistry**

Even before hostilities ended on 11 November 1918, scientists in the Allied nations began contemplating the reopening of scientific cooperation through international associations, albeit minus the members of the Central Powers.<sup>600</sup> The seeds of the International Research Council (IRC) were sown in a meeting hosted by

---

<sup>598</sup> F. W. Clarke, T. E. Thorpe, W. Ostwald, and G. Urbain, “Annual Report of the International Committee on Atomic Weights, 1914,” *Journal of the American Chemical Society* 35 (1913): 1807, doi:10.1021/ja02201a001.

<sup>599</sup> “International Association of Chemical Societies,” *Journal of the American Chemical Society* 36 (1914): 84, doi:10.1021/ja02178a009.

<sup>600</sup> “Memorandum of Committee on International Scientific Organisations,” *Chemical News* 117 (1918): 283-287, 311-313, <https://hdl.handle.net/2027/mdp.39015073139654?urlappend=%3Bseq=339>.

the Royal Society in early October 1918.<sup>601</sup> The membership of IRC, eventually renamed the International Council of Scientific Unions (ICSU), was to be composed of “international organisations to meet the requirements of the various branches of scientific and industrial research,” each of which would have membership composed of “a National Council for the promotion of the researches specified.”<sup>602</sup> In other words, an international union of each branch of science would be formed, the membership being composed of one representative association from each nation.<sup>603</sup>

Not long after this meeting, representatives of the national chemical societies met to discuss the future. Plans were put into motion to set up a new international chemical organization to replace the IASC and conform to the terms recommended by the conference on international scientific organizations. However, the IASC had never been formally dissolved. In 1919, a vote by members was held to determine if the IASC should be disbanded, as “it was the opinion that it would not be possible for fruitful cooperation to continue between representatives of the Chemical Societies of the Allies and those of the Central Powers.”<sup>604</sup> This cleared the path for the creation of the new international organization. At the Interallied Chemical Conference in July 1919, it was decided that the International Union of Pure and

---

<sup>601</sup> “Preliminary Report of the Inter-Allied Conference on International Scientific Organisations,” *Chemical News* 117 (1918): 351-352, <https://hdl.handle.net/2027/mdp.39015073139654?urlappend=%3Bseq=415>.

<sup>602</sup> “Preliminary Report,” 351, 352.

<sup>603</sup> Today, for example, the Royal Chemical Society is the UK representative to the IUPAC whereas the National Academy of Sciences is the American representative. These are referred to as National Adhering Organizations.

<sup>604</sup> Roger Fennell, *History of IUPAC, 1919-1987* (London: Blackwell Science, 1994): 17.

Applied Chemistry (IUPAC) should form the chemical section of the IRC, a decision confirmed at the IRC meeting a few days later.<sup>605</sup>

The IUPAC had essentially the same concerns as had the IASC before the war. At the first meeting, held in 1920, the general organization and administration of the new organization was discussed. The duties of each National Committee were to “include the study of questions interesting to chemistry from scientific, industrial, and economic points of view.”<sup>606</sup> Standardization was therefore of great interest. An Institute of Chemical Standards was planned, consisting of three parts: chemical standards (based at the existing Institut International de Chimie Solvay in Brussels), pure products for research, and technological products.<sup>607</sup> Reports were made on topics such as the unification of presentation of analytical results on food materials, atomic weights, physicochemical symbols, and tables of constants.<sup>608</sup>

### **The Commission on Atomic Weights**

The original International Committee on Atomic Weights (minus its German member) had continued to publish reports during the war, although these contained little research in comparison to those of the pre-war years. In its report for 1919-1920, the International Committee commented: “Now that peace is in sight, it seems wise to resume the preparation of these reports, even though they may not be for

---

<sup>605</sup> “The Interallied Chemical Conference,” *Science*, n.s., 50 (1919): 224-225, <http://www.jstor.org/stable/1642166>.

<sup>606</sup> Charles Lormand, “The International Chemical Conference,” *Journal of Industrial and Engineering Chemistry* 12 (1920): 926, doi:10.1021/ie50129a030.

<sup>607</sup> Fennell, *History*, 36. The IUPAC Institute of Chemical Standards dissolved within a decade and its three sections were turned into commissions.

<sup>608</sup> Lormand, “International,” 926.

some time quite so truly international as heretofore.”<sup>609</sup> Agreeing with this sentiment, the IUPAC decided it should establish an International Committee on Atomic Weights. Rather than setting up an entirely new committee, they requested that the non-German members of the original International Committee continue their work under their auspices.<sup>610</sup> This was a more formal arrangement than the pre-war affiliation with the IASC, as the International Committee became a part of the IUPAC.

The integration of the International Committee on Atomic Weights into the IUPAC was quickly followed by a reorganization of the committee, adopted at the second IUPAC meeting in 1921. There it was decided to create a new Committee on Chemical Elements which would not only issue reports on and tables of atomic weights, but also “fix numerical data in the field of radioactivity.”<sup>611</sup> The official history of the IUPAC does not mention what was essentially the disbanding of the International Committee on Atomic Weights. It reports merely that a new commission was created with three subcommissions: atomic weights, isotopes, and radioactive substances.<sup>612</sup> This was an odd collection of topics to be under the

---

<sup>609</sup> F. W. Clarke, T. E. Thorpe, and G. Urbain, “Report of the International Committee on Atomic Weights for 1919-20,” *Journal of the American Chemical Society* 41 (1919): 1881, doi:10.1021/ja02233a600. Germans may no longer have been welcome as members of the committee but the work of German researchers on atomic weights was still evaluated and cited in the International Committee’s reports.

<sup>610</sup> Lormand, “International,” 926.

<sup>611</sup> Charles Lormand, “The Second International Chemical Conference,” *Journal of Industrial and Engineering Chemistry* 13 (1921): 737, doi:10.1021/ie50140a031.

<sup>612</sup> Fennell, *History*, 37. The IUPAC uses the term “commission” rather than “committee” and while they are consistent in its use in their publications, both terms are used by others.

purview of a single committee. Although there was some overlap between these areas, they were also ones that inspired divisions amongst chemists, many of whom were still questioning the importance of radioactivity and isotopes to chemical research. It also called into question the place of atomic weights in chemistry, a research area of the greatest importance during the nineteenth century.

One reason for the creation of the new commission was given in the report of the second IUPAC meeting, which appeared in *Nature*:

It was felt that the exact determination of atomic weights and their publication to several places of decimals has now lost a good deal of its scientific significance in view of the work of Dr. Aston and others, and that exact atomic weights are now becoming factors of analytical calculation rather than features of a chemical hypothesis.<sup>613</sup>

The report asserted atomic numbers were taking “the premier place” over atomic weights which were now only of practical rather than theoretical interest. It was for this reason that the committee was “enlarg[ing] its jurisdiction.”<sup>614</sup> This report was unsigned and it is unclear if these ideas regarding atomic weights were a personal opinion or the opinion of many chemists in attendance at the conference.

Wherever these ideas came from, they were not shared by the members of the new International Commission on Chemical Elements. Bohuslav Brauner wrote to the *Chemical News* to express his disagreement with the report in *Nature*. The official report, he said, “sounds a little differently.” He quoted William Pope, one of the Vice Presidents of the IUPAC, as remarking that as “work of all kinds is modifying the fundamental notion of the element, and so the constitution

---

<sup>613</sup> “International Conference of Chemistry,” *Nature* 107 (1921): 787, doi:10.1038/107787a0.

<sup>614</sup> “International Conference of Chemistry,” 788.

(establishment) of the Table of Atomic Weights does not present the same interest as it presented at the epoch when atomic weights were regarded as absolute constants.”<sup>615</sup> Brauner argued that most chemists would agree with this statement, however he strongly disagreed that atomic weights no longer had any theoretical interest. He was not alone in this sentiment. T. E. Thorpe, one of the original members of the International Committee, said in his inaugural address before the British Association:

The term “atomic weight” has thus acquired for the chemist an altogether new and much wider significance. It has long been recognised that it has a far deeper import than as a constant useful in chemical arithmetic. ... Their determination and study must now be of the essential nature of matter and on the “superlatively grand question: What is the inner mechanism of the atom?” they become of supreme importance.<sup>616</sup>

He noted that “in view of recent developments,” the International Committee had been reorganized which “resulted in strengthening the constitution of the Committee and in a wide extension of its scope.”<sup>617</sup>

The nature of these “recent developments” was revealed in the new Committee’s first report, published in 1923: “The discovery of isotopy first in the domain of radioactive elements, later in that of non-radioactive elements, produced new problems not only concerning atomic weights, but also affecting the conception of a chemical element.” Therefore the new International Committee on Chemical

---

<sup>615</sup> Bohuslav Brauner, “The New International Commission on Chemical Elements,” *Chemical News* 123 (1921): 230,

<https://hdl.handle.net/2027/mdp.39015073139811?urlappend=%3Bseq=274>.

<sup>616</sup> T. Edward Thorpe, “The Presidential Address,” *Report of the Eighty-Ninth Meeting of the British Association for the Advancement of Science* (London: John Murray, 1922): 20, <https://biodiversitylibrary.org/page/30497586>.

<sup>617</sup> Thorpe, “Presidential Address,” 20.

Elements would “keep chemists informed of the various advances made each year in this field already rich and so full of promise for the future.” To that end, they would continue to prepare a table of atomic weights, but also two new tables – one of radioactive elements with their principle constants and one of isotopes.<sup>618</sup>

Given the new Committee’s expanded purview, it is not surprising that its membership changed significantly. With the advent of war, the membership of the International Committee on Atomic Weights had shrunk to just the three members from the Allied nations: F. W. Clarke, T. E. Thorpe, and Georges Urbain. All of them were chemists and had been members of the committee for most of its existence. The new Committee had a more diverse membership, incorporating not only chemists but physicists, as well.<sup>619</sup> Urbain, a rare earths specialist, was the only continuing member. The rest of the Committee consisted of F. W. Aston, a chemist and physicist whose mass spectrograph had been the means for proving that many non-radioactive elements had isotopes; Gregory P. Baxter, who succeeded Clarke as the sole member of the American Chemical Society’s atomic weights committee; Brauner, a rare earths specialist who was one of Mendeleev’s earliest disciples; Andre Debierne, a chemist who worked with Marie Curie; Anatole Leduc, a physicist who worked on thermoelectricity and gases; T. W. Richards, an expert on the

---

<sup>618</sup> F. W. Aston, et al., “Report of the International Committee on Chemical Elements, 1923,” *Journal of the American Chemical Society* 45 (1923): 867, doi:10.1021/ja01657a001.

<sup>619</sup> It may seem odd for physicists to be members of a chemical committee, however, many chemists, particularly those involved in radioactivity research, were often found in physics departments. Boltwood considered himself a chemist but was made a professor of physics due to his interest in the physical aspects of chemistry. Aston considered himself to be both a chemist and a physicist.

determination of atomic weights; and Frederick Soddy, a radiochemist. This was a fairly even split between atomic weight experts and radioactivity experts.

During its first year, the Committee focused much of its work not on atomic weights but on the creation of the two new tables. They considered much of this work to be provisional, largely because there were issues surrounding definitions and nomenclature that needed to be resolved. As discussed in the Chapter 4, there was no standardized nomenclature for radio-elements. Despite pleas from some chemists, Rutherford and many other radioactivists had preferred to wait until it seemed likely most of these elements had been discovered. Standardized nomenclature was scheduled for discussion at the third meeting of the International Radiological Congress in 1915, however this meeting was not held due to the war. The Committee noted that “a general reform of the nomenclature of radioactive elements” was needed. In the absence of such a standard, they had “respected as far as possible the names given by the discoverers.”<sup>620</sup> Along with names, the Committee also adopted a set of symbols and notations to be used in the table of radioactive constants. They felt it was “desirable” that this be “accepted universally” but it was also “designed to serve as a basis of discussion” toward the development of a standard nomenclature.<sup>621</sup>

---

<sup>620</sup> Aston, et al., “Report,” 868.

<sup>621</sup> Aston, et al., “Report,” 870. It is not clear if the International Committee on Chemical Elements was to be responsible for developing a standardized nomenclature for radioactivity and radioelements. The IUPAC created three nomenclature commissions (organic, inorganic, and biological chemistry) in 1921. As well, the International Union of Pure and Applied Physics (IUPAP) was formed in 1922 and it is likely they would have been interested in the development of a nomenclature for radioactivity. It wasn’t until 1931, however, that the IUPAP created the Commission on Symbols, Units, and Nomenclature.



## **The Conception of the Chemical Element**

The other major issue facing the International Committee on Chemical Elements was the necessity of reconceptualizing the chemical element. The discoveries of radioactivity, isotopy, and the internal structure of the atom necessitated a new definition of the element. Reconceptualizing the periodic law in light of these discoveries was relatively easily accomplished and did not require a committee. It was, in essence, a substitution: atomic number simply replaced atomic weight as the organizing principle. This had the advantage not only of incorporating the new understanding of atomic structure but also of resolving some of the previously existing inconsistencies. It was now clear that the four pair reversals, proposed by Mendeleev, such as that of tellurium and iodine, were desirable as their atomic numbers were in sequence. This substitution also had the advantage of maintaining a clear connection to the original conception of the periodic law. As Soddy said in an address before the Chemical Society in 1918, "It is clear that the periodic law connects, not primarily chemical character and atomic weight, but chemical character and atomic charge or atomic number."<sup>622</sup>

But the reconception of the element would not be as easily accomplished as substituting one characteristic of an element for another. There was a long-standing understanding of the element. In his 1899 survey of the definition of the element, Francis Preston Venable quoted Lavoisier's definition as "an element is a substance from which no simpler body has yet been obtained; a body in which no change

---

<sup>622</sup> Frederick Soddy, "The Conception of the Chemical Element as Enlarged by the Study of Radioactive Change," *Journal of the Chemical Society* 115 (1919): 20, doi:10.1039/CT9191500001.

causes a diminution in weight. Every substance is to be regarded as an element until it is proved to be otherwise'.<sup>623</sup> From Dalton's atomic theory were added the ideas that each element had a unique atomic weight and that all the atoms of an element were the same. According to Soddy, these definitions incorporated a fallacy, "that chemical analysis was necessarily the most fundamental and searching kind of material analysis."<sup>624</sup> The element then became the chemical element, which possessed unique chemical characteristics such as atomic weight and spectrum. Ultimately, according to Soddy, "the periodic law became the court of appeal," requiring substances to not only have unique atomic weight and spectrum but also a unique place in the periodic table.<sup>625</sup>

The discovery of radioactivity and the resulting concept of isotopy challenged previous conceptions about elements requiring a unique spectra and a unique atomic weight. Isotopes of the same element have different atomic weights and different spectra but share the same place on the periodic table. Were isotopes different chemical elements or different species of the same chemical element? Were isotopes chemically identical? Answering these questions would lead to a reconceptualization of the chemical element, one that would require chemists to further accept the intrusion of physics into the heart of their science.

The British chemist Henry Armstrong spoke for many when he stated in 1914: "It is doubtful if it be permissible at present to conclude that elements of

---

<sup>623</sup> F. P. Venable, "The Definition of the Element," *Science*, n.s., 10 (1899): 275, <http://www.jstor.org/stable/1626614>.

<sup>624</sup> Soddy, "The Conception," 10.

<sup>625</sup> Soddy, "The Conception," 11.

different atomic weight may and do exist which are indistinguishable chemically.”<sup>626</sup>

Kasimir Fajans, who had co-discovered the group displacement laws that were integral to the concept of isotopy, himself believed that isotopes were not chemically identical, only similar, and therefore should be considered different elements. During the early years of World War I, Fajans became embroiled in a dispute with the Austrian radiochemists Fritz Paneth and George Hevesy over this question. Paneth and Hevesy argued that isotopes belonged to the same chemical species as they exhibited chemical replaceability. In other words, the chemical behavior of one isotope was indistinguishable from that of another isotope of the same element. Their explanation hinged, however, on physics. Because isotopes have the same atomic number, they have the same place in the periodic table, and because they have the same electron configuration, their chemical action is the same. Isotopes were not absolutely identical, however, because some properties, particularly entropic and thermodynamic ones, were dependent on the mass of the particles. Fajans argued in response “that thermodynamic and chemical differences were essentially the same thing” thus isotopes were not chemically identical.<sup>627</sup>

Fajans and Hevesy and Paneth eventually agreed to disagree. Paneth, however, continued to think about the chemical conception of the elements. In a 1916 paper he suggested the definition of the element, from the standpoint of the

---

<sup>626</sup> “Discussion on the Structure of Atoms and Molecules,” *Report of the Eighty-Fourth Meeting of the British Association for the Advancement of Science, Australia, 1914* (London: John Murray, 1915): 294, <https://biodiversitylibrary.org/page/30399786>.

<sup>627</sup> Helge Kragh, “Conceptual Changes in Chemistry: The Notion of a Chemical Element, ca. 1900-1925,” *Studies in History and Philosophy of Modern Physics* 31 (2000): 441, doi:10.1016/S1355-2198(00)00025-3.

Rutherford-Bohr atomic model, could be, “a substance whose atoms all have the same nuclear charge.”<sup>628</sup> Alternatively, and more practically, he suggested the definition, “a substance that cannot be decomposed by any chemical process into a simpler one. Substances that meet this definition are regarded as one and the same element, when, once mixed together, cannot be separated again by any chemical process.”<sup>629</sup> With this alternate definition, Paneth harkened back to Lavoisier’s conception of an element, perhaps making it more attractive to chemists than the other, more physical, definition.

However, a more physical definition for the chemical element was increasingly hard to ignore. In 1921, the German committee on atomic weights released a new table of the elements based on atomic number. They stated, “The determining factor for the chemical nature of an element is the atomic number, which clearly defines its place in the periodic system.”<sup>630</sup> As atomic number was equal to nuclear charge, this was the equivalent of an endorsement of the physical definition of the element. Part of their justification for this decision lay in Aston’s

---

<sup>628</sup> Fritz Paneth, “Über den Element- und Atombegriff in Chemie und Radiologie,” *Zeitschrift für Physikalische Chemie* 91 (1916): 194, <https://hdl.handle.net/2027/umn.31951000633920w?urlappend=%3Bseq=181>; “Ein Element ist ein Stoff, dessen sämtliche Atome gleiche Kernladung haben.”

<sup>629</sup> Paneth, “Über den Element-,” 198; “Ein Element ist ein Stoff, der durch kein chemisches Verfahren in einfachere zerlegt werden kann. Stoffe, die dieser Definition genügen, gelten als ein und dasselbe Element, wenn sie, einmal miteinander gemischt, durch kein chemisches Verfahren wieder getrennt werden können.”

<sup>630</sup> M. Bodenstein, et al., “Atomgewichtstabellen für das Jahr 1921,” *Berichte der Deutschen Chemischen Gesellschaft* 54A (1921): 182, <https://hdl.handle.net/2027/mdp.39015026351513?urlappend=%3Bseq=197>; “Bestimmend für die chemische Natur eines Elementes ist die Ordnungszahl, die seinen Platz im periodischen System eindeutig festlegt.”

work, which determined it was not only the radioactive elements that had isotopes but the majority of non-radioactive elements did as well. Aston was in agreement that “the association of element with atomic number ... is much the more preferable” to calling each isotope an element. The use of atomic number as the definition of the element “fix[es] the word precisely, now and for the future, as meaning a substance with definite chemical and spectroscopic properties which may or may not be a mixture of isotopes.”<sup>631</sup>

Fajans, who had continued to cling to the belief that isotopes were different elements, conceded defeat in 1922. In the preface to the fourth edition of his textbook on radioactivity, he admitted that “the conception of isotopes as varieties of the same chemical element” was one which “possesse[d] several practical advantages in spite of its great and essential disadvantages.”<sup>632</sup> He had therefore reorganized the book to reflect this concept. In summarizing the history of radioactivity to the present, he wrote:

Not only isotopy, but also the artificial decomposition of atoms necessitates a radical alteration in the definition of an element, for it becomes necessary, 250 years after Boyle, to reject the criterion of the “cannot be,” or “has not been” decomposed, if it is still desired – and there can be no doubt about this – to regard as elements substances like nitrogen, fluorine, etc.<sup>633</sup>

---

<sup>631</sup> F. W. Aston, *Isotopes* (London: Edward Arnold & Co., 1922): 115-116, <https://archive.org/details/isotopes00asto>.

<sup>632</sup> K. Fajans, *Radioactivity and the Latest Developments in the Study of the Chemical Elements*, trans. from the 4<sup>th</sup> German ed. by T. S. Wheeler and W. G. King (London: Methuen & Co. Ltd., 1923): xii.

<sup>633</sup> Fajans, *Radioactivity*, 110. Boyle was often mentioned in discussions surrounding the conception of the chemical element. Paneth invoked Boyle’s definition in his 1916 paper, as did Soddy in his 1918 address before the Chemical Society.

Coming up with this “radical alteration” would be the task of the International Committee on Chemical Elements. Given that the membership of the committee included Aston and Soddy, as well as several physically-inclined chemists, it is not surprising that the definition of the element they agreed upon was a physical one.

The new definition appeared in the first report of the International Committee, published in 1923, which stated:

A chemical element is defined by its atomic number. This number represents the excess of positive over negative charges in the constitution of the atomic nucleus; theoretically, the atomic number represents also the number of electrons which rotate round the central positive nucleus of the atom. Each atomic number also represents the place occupied by the element in the Mendeleef table.<sup>634</sup>

This definition was undoubtedly physical, despite the use of the phrase “chemical element.” It made no mention of the possibility of decomposing a substance further by chemical processes, thus breaking all ties to nineteenth century definitions of the element. Rather, it made a statement regarding the internal structure of the atom, which was still not yet completely known or understood. It also, consciously or not, echoed the German committee on atomic weights in stating that the atomic number represented an element’s place in the periodic system.

In addition to cementing the atomic number as the defining characteristic of an element, the International Committee had some further things to say about isotopes and the nature of the elements: “If the above definition is accepted, each chemical element may be simple or complex, according as its atoms are all of equal mass or not. In the latter case, the element consists of as many isotopes as its atoms

---

<sup>634</sup> F. W. Aston, et al., “Report,” 868.

have different masses. A complex element is a mixture of isotopes.”<sup>635</sup> This statement was undoubtedly in response to those chemists who, much like Fajans, had yet to accept that isotopes were not separate elements. At the 1922 Solway Institute of Chemistry meeting, Aston’s (and the International Committee’s) definition was challenged, “by a number of chemists, who argued that the word ‘element’ carried with it an idea of homogeneity which could not be reconciled with the proposal to describe as an element a mixture of isotopes, the separation of which might at any time become a practical possibility.”<sup>636</sup> This position, of course, reflected Lavoisier’s definition of an element, which left open the possibility for new analytical techniques that could prove that a substance was not in fact an element.

The use of the descriptors “simple” and “complex” in reference to the chemical element in the International Committee’s report operated on more than one level. One level was related to the concept of isotopy and in turn related to late nineteenth century ideas about the evolution of the elements, as well as to Prout’s hypothesis. Norman Lockyer had postulated that the elements were compound bodies, composed of atoms and subatoms, which, at high temperatures, could dissociate into elements of lighter atomic weight. Similarly, William Crookes had suggested that elements were compound molecules, composed of the primordial *protyle* which coalesced into elements of lighter atomic weight and further combined to make elements of higher atomic weight. With the discovery of the electron, some had begun to suggest that the electron was the *protyle*. By the early

---

<sup>635</sup> Aston, et al., “Report,” 869-870.

<sup>636</sup> “The Solway Institute of Chemistry,” *Nature* 109: 719, doi:10.1038/109718a0.

1920s, the electron was still a favorite candidate. However, given the importance of electrical charge in atoms, particularly as a binding force, electricity itself was also being suggested as the *protyle*.

The leap from electrons to electricity was not a great one. Electrons were known to be negatively charged particles. In 1908, William Ramsay had stated that electrons were atoms of the element electricity. Not many chemists were accepting of this notion, however the fact that it was suggested did mean chemists were thinking about electricity as a fundamental force. In his radioactivity text, Fajans reminded his readers that Prout had suggested hydrogen was the primordial matter. However, even hydrogen was now known to be composed of an atom of positive electricity and an atom of negative electricity. It could only be concluded, Fajans wrote, that “electricity then is the long-sought primordial matter, of which all elements and consequently the whole world are constructed.”<sup>637</sup> Aston had come to a similar conclusion, though he did not go so far as to say electricity itself was the *protyle*. Rather, he stated, “The atom of protyle regarded according to modern views is a neutral pair of oppositely charged atoms of electricity closely combined.”<sup>638</sup> Prout's hypothesis that all elements were composed of a common substance, the *protyle*, had been “to a certain extent substantiated,” it just wasn't hydrogen as Prout had suggested.<sup>639</sup>

---

<sup>637</sup> Fajans, *Radioactivity*, 114.

<sup>638</sup> F. W. Aston, “Mass-Spectra and the Atomic Weights of the Elements,” *Science Progress in the Twentieth Century* 15 (1920): 221, <https://hdl.handle.net/2027/njp.32101076203833?urlappend=%3Bseq=226>.

<sup>639</sup> Aston, “Mass-Spectra,” 221.



The other level on which the descriptors “simple” and “complex” in reference to the chemical element operated was a much more philosophical one. The term “simple substance” had often been used interchangeably with the term “element.” Mendeleev, however, had been insistent that a “simple substance,” or a “simple body,” was not the same thing as an “element.” He stated:

A “simple body” is something material ... endowed with physical properties, and capable of chemical reactions. The idea of a molecule corresponds with the expression of a “simple body” .... A simple body ... is only distinguished from a compound body by the homogeneity of its material parts. But in opposition to this, the name of “element” must be reserved for characterising the material particles which form simple and compound bodies, and which determine their behaviour from a chemical and physical point of view. The word “element” calls to mind the idea of an atom; carbon is an element; coal, diamond, and graphite are simple bodies.<sup>640</sup>

Simple bodies could combine to form complex bodies. But within the combined form, the elements remained unchanged. For example, the elements carbon, hydrogen, oxygen, nitrogen, and sulfur each retained their properties despite being combined into the substance coal, which may have different properties from those of the individual elements. This was a very philosophical notion of an element, an unchanging body which retained its properties even in combination.

This philosophical view was not very popular amongst chemists. Most continued to equate elements with simple bodies or simple substances. In the wake of the changes wrought by radioactivity, however, a few chemists took a more

---

<sup>640</sup> D. Mendeleef, “The Periodic Law of the Chemical Elements,” *Chemical News* 40 (1879): 231-232, 243-244, 255-256, 267-268, 279-280, 291-292, 303-304; 41 (1880): 2-3, 27-28, 39-40, 49-50, 61-62, 71-72, 83-84, 93-94, 106-108, 113-114, 125-126; quote on 243, <https://hdl.handle.net/2027/wu.89100444694?urlappend=%3Bseq=241>; <https://hdl.handle.net/2027/mdp.39015073203989?urlappend=%3Bseq=10>.

philosophical view of the elements. One of these was Paneth, although his metaphysical understanding was grounded in physics. In a 1931 lecture, Paneth stated that “chemistry is a science in which interest is directed towards the secondary qualities of substances”; that is, chemists rely on their senses to understand substances which has led to “the chemist’s naive notion of substance.”<sup>641</sup> For Paneth, the definition of the element as presented by Lavoisier contained two different meanings for elements. One, the basic substance, referred to “the indestructible substance present in compounds and simple substances,” while the other, the simple substance, referred to the form “in which an isolated basic substance uncombined with any other appears to our senses.”<sup>642</sup> Paneth’s basic substance was essentially equivalent to Mendeleev’s element, the substance which remained unchanged even in combination with other substances. Although the main text of his lecture focused on chemistry, in a footnote Paneth stated that the physical atomic theory “enables us to visualise particularly vividly how we are to understand the persistence of an element in its compounds.”<sup>643</sup> Properties seem to have disappeared because the electron shells of the atoms have undergone changes (the exceptions being atomic weight and radioactivity as they are determined by the atomic nucleus rather than by the electrons). As long as the atomic nuclei are not destroyed, the original properties can be recovered when the electrons are returned to their original positions.

---

<sup>641</sup> F. A. Paneth, “The Epistemological Status of the Chemical Concept of the Element,” *British Journal for the Philosophy of Science* 13 (1962): 8, 9, <http://www.jstor.org/stable/685220>.

<sup>642</sup> Paneth, “Epistemological,” 150.

<sup>643</sup> Paneth, “Epistemological,” 152.

Another chemist who took a more philosophical view of the chemical elements was Urbain, who had been chair of the International Committee on Chemical Elements in 1923 when they redefined the element. Much like Paneth, Urbain argued that the term simple body was not the equivalent of the term element, despite the fact that they were commonly considered to be synonyms. Rather, “The simple body is a particular substance, a chemical species,” whereas the element is “an abstraction.”<sup>644</sup> For example, oxygen (O<sup>2</sup>) and ozone (O<sup>3</sup>) differ markedly in their properties but are both made of same matter. We can precisely describe oxygen and ozone but the common matter that they are composed of cannot be known and described in the same manner. That common matter is the element oxygen (O), a substance that is purely an idea, defying description.

Advances in science rendered the traditional notion of a simple substance obsolete, leaving chemists “to appeal to the subtleties,” differentiating between chemical and physical analytical techniques in order to retain the old notion of a simple substance.<sup>645</sup> Urbain found this “scandalous” and saw no need to differentiate between chemistry and physics.<sup>646</sup> Touching on the new definition of the element produced by the International Committee, Urbain noted that it took little account of “the etymological sense of the word element” and that this new

---

<sup>644</sup> Georges Urbain, *Les Notions Fondamentales d'Élément Chimique et d'Atome* (Paris: Gauthier-Villars et Cie., 1925): 8, 15; “Le corps simple est une substance déterminée, une espèce chimique.”; “... l'élément est une abstraction.”.

<sup>645</sup> Urbain, *Notions*, 10; “...il sera nécessaire de faire appel à des subtilités....”.

<sup>646</sup> Urbain, *Notions*, 11; “Il est surprenant que la plupart des savants n'en soient pas scandalisés.”.

definition was considered to be provisional. But then, he wondered, in physical science “can definitions be other than temporary?”<sup>647</sup>

The definition developed by the International Committee may have been considered to be provisional, yet the definition has remained essentially the same. The current version of the IUPAC Gold Book<sup>648</sup> provides two definitions for the term chemical element. The first is fairly straightforward and states that a chemical element is, “A species of atoms; all atoms with the same number of protons in the atomic nucleus.” The second definition provided is especially interesting considering the philosophical discussions surrounding chemical elements and simple substances. It reads: “A pure chemical substance composed of atoms with the same number of protons in the atomic nucleus. Sometimes this concept is called the elementary substance as distinct from the chemical element as defined under [the first definition], but mostly the term chemical element is used for both concepts.”<sup>649</sup> This second definition is an acknowledgement of the issues raised by Mendeleev, Paneth, and Urbain, while also acknowledging that most chemists will continue to use the terms simple body, elementary substance, and element interchangeably.

---

<sup>647</sup> Urbain, *Notions*, 49-50; “Je crains que bien des chimistes se satisfassent mal d’une définition de l’élément chimique qui tient si peu compte du sens étymologique du terme élément.”; “Aussi bien, en matière de sciences physiques, les définitions peuvent-elles être autrement que provisoires?”.

<sup>648</sup> The IUPAC’s books on nomenclature and terminology are generally referred to as the color books. The Gold Book is the chemical terminology book, while the Red Book is the guide to inorganic chemistry nomenclature, the Blue Book is the guide to organic chemistry nomenclature, etc.

<sup>649</sup> IUPAC, *Compendium of Chemical Terminology* (the “Gold Book”), XML on-line corrected version of the 2<sup>nd</sup> ed. (1997); available at <http://goldbook.iupac.org/>. Direct link to “chemical element”: <http://goldbook.iupac.org/C01022.html>.

## IUPAC and the Periodic Table

The IUPAC would have been the likely organization for creating a standard form of the periodic table. They are the home of the committee that sets atomic weights. They developed a new definition of the element. The IUPAC's Commission on Nomenclature for Inorganic Chemistry (CNIC) began standardizing the names and symbols of the elements before World War II, a project finished in the 1950s. The CNIC shared the responsibility for naming new elements with the atomic weights commission until the 1950s when the atomic weights committee ceded its responsibility. The CNIC has also issued recommendations regarding the labeling of groups on the periodic table. Yet in 2009, G. Jeffery Leigh, who was a member of the CNIC and is currently a member of the Chemical Nomenclature and Structure Representation Division (CNSR), wrote, "IUPAC has not approved any specific form of the periodic table, and an IUPAC-approved form does not exist."<sup>650</sup>

The CNIC has, in fact, discussed the form of the periodic table multiple times during the second half of the twentieth century. These discussions remain confined within correspondence and meeting minutes, and the CNIC did not issue an official statement regarding the form of the periodic table prior to its dissolution in 2001. They came very close, in the early 1960s (more about which later) but determined that their recommendation "was considered to be too controversial and was left aside as not being a question of nomenclature proper."<sup>651</sup> This remained the official

---

<sup>650</sup> Leigh, "Periodic Tables," 4.

<sup>651</sup> K. A. Jensen, "Report of the Commission on the Nomenclature of Inorganic Chemistry," [1963], International Union of Pure and Applied Chemistry (IUPAC) Archive, Chemical Heritage Foundation, Philadelphia, Box 46, Folder 1.

position of the CNIC. In the 1990 edition of the rules of inorganic nomenclature, the CNIC presented three forms of the periodic table: a short form (8-column), a standard form (18-column), and a long form (32-column). They included multiple forms as “it is neither the intent, nor the purpose of the IUPAC Commission on the Nomenclature of Inorganic Chemistry arbitrarily to set the format of the Periodic Table to be used in all parts of the world.”<sup>652</sup>

The IUPAC underwent a significant change in organizational structure which took effect in 2001. As a result of this change, the CNIC ceased to exist and its duties were transferred to the new CNSR Division. In the short time the CNSR has been in existence, they have discussed the form of the periodic table on several occasions. In 2009, they received a proposal for a new form and the minutes reflect that “it was generally acknowledged that: IUPAC cannot control periodic tables around the world; IUPAC is not entitled to ‘give permission’ to do this or that; and IUPAC will not endorse particular proposals.”<sup>653</sup> A new discussion occurred in 2013 when the IUPAC was asked to consider taking a stand on the membership of elements in particular groups. The CNSR decided “that organization of the Periodic Table was not the business of the Division nor, indeed, of IUPAC.”<sup>654</sup> It is clear, then, that while

---

<sup>652</sup> G. J. Leigh, ed., *Nomenclature of Inorganic Chemistry: Recommendations 1990* (Oxford: Blackwell Scientific Publications, 1990): 280.

<sup>653</sup> “Minutes, Division VIII Committee meeting, Glasgow, 2009,” available at [http://www.iupac.org/fileadmin/user\\_upload/divisions/VIII/VIII\\_09min.pdf](http://www.iupac.org/fileadmin/user_upload/divisions/VIII/VIII_09min.pdf)

<sup>654</sup> “Minutes of Division VIII Committee meeting, Istanbul 2013,” available at [http://www.iupac.org/fileadmin/user\\_upload/divisions/VIII/VIII\\_13min.pdf](http://www.iupac.org/fileadmin/user_upload/divisions/VIII/VIII_13min.pdf) Despite this statement, in December 2015, the IUPAC authorized a new project for the purpose of recommending the composition of group 3 of the periodic table, although the task group does not intend to recommend the adoption or use of either the 18-column or 32-column long form table; see [http://iupac.org/projects/project-details/?project\\_nr=2015-039-2-200](http://iupac.org/projects/project-details/?project_nr=2015-039-2-200).

the IUPAC is willing to discuss the periodic table, they are not willing to make any recommendations as to its organization or its form.

### **Pedagogy and the Standard Periodic Table**

It is clear that the IUPAC has not played a role in the creation of the standard form of the periodic table. Indeed, it does not seem that *any* organization has played a significant role. Some chemists, such as Paneth, found this a good thing. In a 1950 letter, he wrote, “It is rather fortunate that it is not necessary to lay down by decision [of] any commission which periodic table should be generally accepted!”<sup>655</sup> Different forms of the periodic table emphasized different aspects of the elements and their relationships, as Paneth makes clear in the letter: “I believe that the chief difference is that you [Glenn Seaborg] are using the periodic table to express the probable configuration of the electron shells, while I and a few other chemists are primarily concerned with the representation of the chemical character of the elements.” Paneth had earlier made clear in a 1923 article that different forms of the periodic table were useful either for research or for education. He considered the Bohr form of the Bayley-Thomsen table (Fig. 1)<sup>656</sup>, which rather resembles a rocket ship, to be “authoritative for any deeper penetration into the question of the relationship of the periodic system and atomic structure.”<sup>657</sup> For educational

---

<sup>655</sup> F. A. Paneth to G. T. Seaborg, 14 July 1950, Box 342, Glenn Theodore Seaborg Papers, Manuscript Division, Library of Congress, Washington, D.C.

<sup>656</sup> Niels Bohr, *The Theory of Spectra and Atomic Constitution: Three Essays* (Cambridge: Cambridge University Press, 1922), 70.

<sup>657</sup> Fritz Paneth, “Über die heutige Schreibweise des periodischen Systems der Elemente,” *Zeitschrift für angewandte Chemie* 36 (1923): 410, doi:10.1002/ange.19230365707; “Tabelle 1 endlich ist für jedes tiefere Eindringen in die Frage des Zusammenhangs von periodischem System und Atombau die maßgebende.”.

purposes, Paneth suggested, the only two forms that should be considered were the short form and the long form.<sup>658</sup>

**Figure 5.1: Bohr's Table (1922)**

Throughout the 1920s and into the 1930s, the short form table, an 8-column rectangle based on Mendeleev's 1871 table, continued to be the most popular form of the periodic table in textbooks. William Foster, who touted his *Introduction to General Chemistry* as “the result of more than fifteen years of experience in teaching General Chemistry to large classes of college students,” included only a short table and stated that Mendeleev published his first periodic table in 1871.<sup>659</sup> In fact, this

<sup>658</sup> Paneth, “Über die heutige Schreibweise,” 408; “Wir glauben, daß Tabelle 3 die Stelle der üblichen Darstellungen des periodischen Systems in der Lehrbüchern und Vorlesungen über anorganische Chemie einnehmen kann, und Tabelle 2 dort am Platz ist, wo auch bisher im Unterricht die "langperiodige" Form des Systems der "kurzperiodigen" vorgezogen wurde.”

<sup>659</sup> William Foster, *Introduction to General Chemistry* (Princeton: Princeton University Press, 1924): [i], 264; table on 265.



short form was generally referred to as “Mendeleev’s table.”<sup>660</sup> The short form, however, highlighted the multiple problems with the periodic system, many of which textbook authors felt the need to point out to one degree or another.

PERIODIC CLASSIFICATION OF THE ELEMENTS.

	0	I		II		III		IV		V		VI		VII		VIII																			
1	H 1.008																																		
2	He 4.00																																		
3	Li 6.94	Be 9.01																																	
4	B 10.81	C 12.01	N 14.01	O 16.00													F 19.00																		
5	Ne 20.18	Na 22.99	Mg 24.31	Al 26.98	Si 28.09	P 30.97	S 32.06	Cl 35.45	Ar 39.94								K 39.10	Ca 40.08																	
6	K 39.10	Ca 40.08	Sc 44.96	Ti 47.88	V 50.94	Cr 52.00	Mn 54.94	Fe 55.85	Co 58.93	Ni 58.71	Cu 63.55	Zn 65.37	Ga 70.00	Ge 72.64	As 74.92	Se 78.96	Br 79.90	Rb 85.47	Sr 87.62	Y 88.91	Zr 91.22	Nb 92.91	Mo 95.94	Tc 98.91	Ru 101.07	Rh 102.91	Pd 106.42	Ag 107.87	Cd 112.41	In 114.82	Sn 118.71	Sb 121.76	Te 127.60	I 126.91	Xe 131.29
7	Ra 226.0	Ac 227.0	Th 232.0	Pa 231.0	U 238.0	Np 237.0	Pu 244.0	Am 243.0	Cm 247.0	Bk 247.0	Cf 251.0	Es 252.0	Fm 257.0	Mendelevium 258.1	Nobelium 259.1	Lanthanum 138.9	Cerium 140.1	Praseodymium 140.9	Neodymium 144.2	Europium 151.96	Gadolinium 157.25	Terbium 158.93	Dysprosium 162.50	Ho 164.93	Erbium 167.26	Thulium 168.93	Ytterbium 173.05	Lutetium 174.97	Ununseptium 288	Ununhexium 289	Ununpentium 290	Ununquadium 291	Ununtrium 292	Unbibium 293	Ununennium 294

**Figure 5.2: Sears’s Table (1924)**

George Wallace Sears, professor of chemistry at the University of Nevada, developed a modification of the Mendeleev table (Fig. 2).<sup>661</sup> It appears to be almost 3-dimensional and bears some resemblance to the Bohr-Bayley-Thomsen table – albeit one turned 90 degrees – yet it is immediately recognizable as a short form table. Sears wrote:

While the main purpose in the preparation of the table has been to secure a simple, compact and readily understood picture of the relative chemical and physical properties of the elements to be used as a basis for the correlation of the facts of chemistry, it is believed it also expresses a logical relation

<sup>660</sup> See, for example, A. F. Holleman, *A Text-book of Inorganic Chemistry*, 6<sup>th</sup> English ed. (New York: John Wiley & Sons, Inc., 1921): 310; B. Smith Hopkins, *General Chemistry for Colleges* (Boston: D. C. Heath and Company, 1930): 266.

<sup>661</sup> Geo. W. Sears, “A New Form of Periodic Table as a Practical Means of Correlating the Facts of Chemistry,” *Journal of Chemical Education* 1 (1924): 175, doi:10.1021/ed001p173.

between the elements in the light of our present conception of atomic structure.<sup>662</sup>

He clearly found his table useful, including it in the first edition of his *Essentials of General Chemistry*, published in 1939.<sup>663</sup> Others found Sears's table useful, as well. Charles Dull included a more traditional Mendeleev table in both his *High School Chemistry* and *Modern Chemistry* textbooks but merely as a historical object, using the Sears table in his discussion of the periodic system.<sup>664</sup>

Despite the continued use of the short form table in textbooks, a long form table was often included as an alternative. In a discussion of the deficiencies of the periodic system, G. Calcagni included Alfred Werner's long form (Fig. 3)<sup>665</sup> as an example of a modification that "eliminate[d] its shortcomings."<sup>666</sup> Werner first published his long form table in 1905<sup>667</sup> and he continued to use it in his textbook in the following decades.<sup>668</sup> His table included 33 columns and required a fold-out plate to accommodate its length. In the 1922 edition of his text on radioactivity,

---

<sup>662</sup> Sears, "A New Form," 177.

<sup>663</sup> Geo. W. Sears, *Essentials of General Chemistry: An Introductory College Course* (Scranton: International Textbook Company, 1939). The version of the table in this text more obviously 3-dimensional; see front flyleaf or page 34.

<sup>664</sup> Charles Dull, *High School Chemistry* (New York: Henry Holt and Company, 1925): chapter XXVI. Charles Dull, *Modern Chemistry* (New York: Henry Holt and Company, 1931): chapter 26.

<sup>665</sup> G. Calcagni, *Trattato di Chimica Generale e Inorganica* (Torino: S. Lattes & C., 1920): foldout following page 304, [https://hdl.handle.net/2027/uc1.\\$b620100](https://hdl.handle.net/2027/uc1.$b620100).

<sup>666</sup> Calcagni, *Trattato*, 303; "Alcuni chimici recentemente hanno creduto opportuno di modificare la tavola di MENDELEJEFF per eliminare i suoi difetti; le modificazioni più importanti sono quella di H. BILTZ e B. BRAUNER e quella di WERNER."

<sup>667</sup> A. Werner, "Beitrag zum Ausbau des periodischen Systems," *Berichte der deutschen chemischen Gesellschaft* 38 (1905): 914-921, <https://hdl.handle.net/2027/iau.31858002459455?urlappend=%3Bseq=922>.

<sup>668</sup> A. Werner, *Neuere Anschauungen auf dem Gebeite der anorganischen Chemie* (Braunschweig: Druck und Verlag von Friedr. Vieweg & Sohn). Werner died in 1919 and the final edition of the text, the 4<sup>th</sup>, was published in 1920.

Fajans included an 18 column long table (Fig. 4) which he said was “in a form evolved by Werner.”<sup>669</sup> The accompanying footnote, possibly written by the translators of the English edition, notes that the table “reminds one more of a remodelling of Werner’s table by P. Pfeiffer ... than of the original table.”<sup>670</sup> Paul Pfeiffer used his table (Fig. 5),<sup>671</sup> a bit different from the one included in Fajans’s text though also 18 columns, for several years in his inorganic chemistry lectures and said it had “proven itself very well.”<sup>672</sup>

**Sistema Periodico di A. Werner.**

																		He	4																															
H																	Be	B	C	N	O	F	Ne																											
1,008																	9,1	11	12	14,04	16	19	20																											
																		Mg	Al	Si	P	S	Cl	A																										
Na																	24,36	27,1	28,4	31	32,06	35,35	39,9																											
																		K	Ca											Sc	Ti	V	Cr	Mn	Fe	Co	Ni	Cu	Zn	Ga	Ge	As	Se	Br	Kr					
39,15	40,1																	44,1	48,1	51,2	52,1	55,0	55,9	59,0	58,7	63,6	65,4	70	72	75	79,1	79,96	81,8																	
																		Rb	Sr											Y	Zr	Nb	Mo			Ru	Rh	Pd	Ag	Cd	In	Sn	Sb	Te	J	X				
85,4	87,6																	89,0	90,7	94	96,0			101,7	103,0	106	107,93	112,4	114	118,5	120	127,6	126,85	128																
																		Ce	Ba	La	Co	Nd	Pr		Sa	Eu	Gd	Tb	Ho	Dy	Er	In	Yb	Tu	Lu		Ta	W		Os	Ir	Pt	Au	Hg	Tl	Pb	Bi			
	133	137,4	138	140	143,6	140,5		150,39	151,79	156	160	162	162,79	166	170	171	174			183	184				191	193	194,8	197,2	200,3	204,1	206,9	208,5																		
		Ra	La $\alpha$	Th		U																									Pb $\alpha$	Bi $\alpha$	Te $\alpha$																	
		225	?	232,5		239,5																																												

**Figure 5.3: Calcagni's version of Werner's table (1920)**

<sup>669</sup> Fajans, *Radioactivity*, 116-117.

<sup>670</sup> Fajans, *Radioactivity*, 129.

<sup>671</sup> Paul Pfeiffer, “Die Befruchtung der Chemie durch die Röntgenstrahlenphysik,” *Naturwissenschaften* 8 (1920): 991, doi:10.1007/BF02448807.

<sup>672</sup> Pfeiffer, “Die Befruchtung,” 991; “sie hat sich sehr gut bewährt.”

Number of Period and Number of the Elements											
2 = 2 × 1 <sup>2</sup>	1H 1,008										
I 8 = 2 × 3 <sup>2</sup>	3Li 6,94	4Be 9	5B 11,30								
II 8 = 2 × 2 <sup>2</sup>	11Na 23	12Mg 24,31; 24	13Al 27								
III 18 = 2 × 3 <sup>3</sup>	19K 39,10	20Ca 40,1	21Sc	22Ti	23V	24Cr	25Mn	26Fe 56			
IV 18 = 2 × 2 <sup>3</sup>	37Rb 85,47	38Sr	39Y	40Zr	41Nb	42Mo	43—	44Ru			
V 32 = 2 × 4 <sup>3</sup>	55Cs 133	56Ba	57La to 71Lu	72Hf	73Ta	74W	75—	76Os			
VI	87—	88Ra (226)	89Ac (227)	90Th (232)	91Pa (231)	92U (238)					

										2He 4,00				
										6C 12	7N 14	8O 16,00	9F 19	10Ne 20,18
										14Si 28,1	15P 31	16S 32	17Cl 35,5	18Ar 39,9
27Co 58,9	28Ni 58,7	29Cu 63,5	30Zn 65,4	31Ga 69,7	32Ge 72,6	33As 74,9	34Se 78,9	35Br 79,9	36Kr 83,8					
45Rh 101,1	46Pd 106,4	47Ag 107,9	48Cd 112,4	49In 114,8	50Sn 118,7	51Sb 120,2	52Te 127,6	53I 126,9	54Xe 131,3					
77Ir 223,1	78Pt 219,1	79Au 197,0	80Hg 200,6	81Tl 204,4	82Pb 207,2	83Bi 208,0	84Po (210)	85—	86Em (223)					

Figure 5.4: Fajans's Table (1922)

Periodisches System der Elemente.

1 H 1,008																	2 He 4,00						
3 Li 6,94																	4 Be 9,1	5 B 11,0	6 C 12,00	7 N 14,01	8 O 16,00	9 F 19,0	10 Ne 20,2
11 Na 23,00																	12 Mg 24,32	13 Al 27,1	14 Si 28,3	15 P 31,04	16 S 32,06	17 Cl 35,46	18 Ar 39,88
19 K 39,10	20 Ca 40,07	21 Sc 44,1	22 Ti 48,1	23 V 51,0	24 Cr 52,0	25 Mn 54,93	26 Fe 55,84	27 Co 58,97	28 Ni 58,68	29 Cu 63,57	30 Zn 65,37	31 Ga 69,9	32 Ge 72,5	33 As 74,96	34 Se 79,2	35 Br 79,92	36 Kr 82,92						
37 Rb 85,45	38 Sr 87,63	39 Y 88,7	40 Zr 90,6	41 Nb 93,5	42 Mo 96,0	43 —	44 Ru 101,7	45 Rh 102,9	46 Pd 106,7	47 Ag 107,88	48 Cd 112,4	49 In 114,8	50 Sn 118,7	51 Sb 120,2	52 Te 127,5	53 J 126,92	54 Xe 130,2						
55 Cs 132,91	56 Ba 137,37	57 La 139,0	58 Ce 140,25	59 Pr 140,9	60 Nd 144,3	61 —	62 Sm 150,4	63 Eu 152,0	64 Gd 157,3	65 Tb 158,9	66 Dy 162,5	67 Ho 163,5	68 Er 167,3	69 Tm 168,9	70 Yb 173,0	71 Lu 174,9	72 —						
87 —	88 Ra 226,0	89 Ac (226)	90 Th 232,15	91 Pa (231)	92 U 238,0																		
		59 Pr 140,9	60 Nd 144,3	61 —	62 Sm 150,4	63 Eu 152,0	64 Gd 157,3	65 Tb 158,9	66 Dy 162,5	67 Ho 163,5	68 Er 167,3	69 Tm 168,9	70 Yb 173,0	71 Lu 174,9	72 —								

Figure 5.5: Pfeiffer's Table (1920)

A somewhat different long form table is the Bayley-Thomsen-Bohr table (see Fig. 1).<sup>673</sup> It was often included in more advanced texts, particularly in inorganic and physical chemistry textbooks. As Paneth noted, this form was considered by many to be the best for examining the relationship between atomic structure and the elements, but it was also considered by some to be a better form than Mendeleev's table for reasons that had nothing to do with atomic structure. In his *Modern Inorganic Chemistry*, published in 1912, J. W. Mellor noted that Bayley's table "emphasizes the relationship and yet the individuality of the subgroups, the character of the transition elements, etc."<sup>674</sup> Ten years later, in his *Comprehensive Treatise on Inorganic and Theoretical Chemistry*, he added with regard to the Bayley table, that "there is one element for each place in the table, and each place in the table is intended for a definite chemical individual."<sup>675</sup> Although this may imply Mellor was not accepting of the concept of isotopy and related discoveries, he was in fact quite clear in the chapter on radioactivity that "it is possible for two or more elements to have the same nuclear charge, and to occupy the same place in the periodic table."<sup>676</sup> Mellor did not, however, use Bohr's adaptation of the Bayley table in his discussion of atomic structure.

---

<sup>673</sup> Bayley, Thomsen, and Bohr all depicted their tables horizontally, like a rocket ship on its side, however the majority of chemistry textbooks flipped the table 90 degrees, making it vertical, like a rocket ship waiting to take off.

<sup>674</sup> J. W. Mellor, *Modern Inorganic Chemistry* (London: Longmans, Green, and Co., 1912): 809, table on 810, [https://hdl.handle.net/2027/uc1.\\$b277859](https://hdl.handle.net/2027/uc1.$b277859).

<sup>675</sup> J. W. Mellor, *A Comprehensive Treatise on Inorganic and Theoretical Chemistry*, vol. 1 (London: Longmans, Green, and Co., 1922): 257, table on 258.

<sup>676</sup> J. W. Mellor, *A Comprehensive Treatise on Inorganic and Theoretical Chemistry*, vol. 4 (London: Longmans, Green, and Co., 1923): 173.

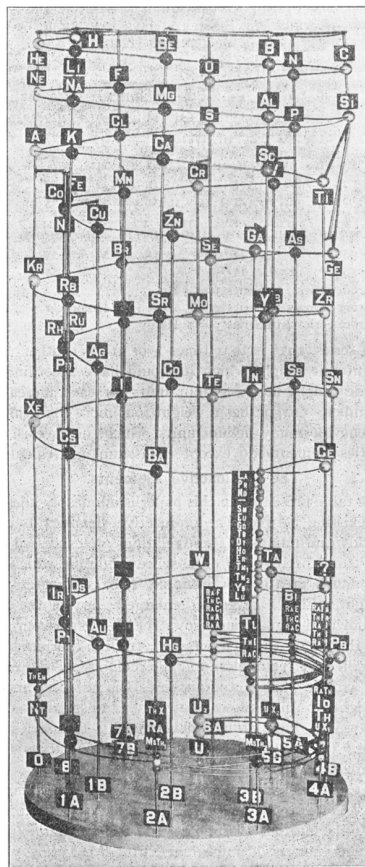

**Figure 5.6: Harkins-Hall 3-D Table (1916)**

Other forms of the periodic table were used, as well. One of the popular forms used in American textbooks was the three-dimensional cylindrical model of William D. Harkins and R. E. Hall (Fig. 6).<sup>677</sup> In the first two editions (1925, 1931) of his *General Chemistry*, H. I. Schlesinger provided a short form table but nevertheless he used the Harkins-Hall model in his discussions of the element groups. The Harkins-Hall model was pictured in the book as well as being on a page at the front

---

<sup>677</sup> William D. Harkins and R. E. Hall, "The Periodic System and the Properties of the Elements," *Journal of the American Chemical Society* 38 (1916): 182, doi:10.1021/ja02259a001.

of the text designed to be removed for student use.<sup>678</sup> In the third edition of his text (1937), however, Schlesinger provided the Harkins-Hall model only as an example of “[o]ther interesting types [that] take the form of spirals or helices,” and used a long form table in his discussion.<sup>679</sup> William McPherson and William Edwards Henderson also included the Harkins-Hall model in the second edition (1921) of their *A Course in General Chemistry*, however it appears on a page in the chapter on the periodic law with no explanation aside from the caption, “A periodic table of the elements arranged in the form of a helix.”<sup>680</sup> The model was not used in the third edition (1927) of their text.

While including two tables in a chemistry textbook was not uncommon, very few texts had more than two. The second edition of McPherson and Henderson’s textbook had a short form table and a Bayley-Thomsen table, as well as the Harkins-Hall model.<sup>681</sup> Joel Hildebrand also included three different periodic tables in the first edition (1918) of his *Principles of Chemistry*. Like many chemists, Hildebrand noted that the Mendeleev table had “defects.”<sup>682</sup> The Bayley-Thomsen table, though “not quite so easily remembered,” had advantages over the Mendeleev table.<sup>683</sup>

---

<sup>678</sup> H. I. Schlesinger, *General Chemistry* (New York: Longmans, Green and Co., 1925 and 1931).

<sup>679</sup> H. I. Schlesinger, *General Chemistry*, 3<sup>rd</sup> ed. (New York: Longmans, Green and Co., 1937): 304.

<sup>680</sup> William McPherson and William Edwards Henderson, *A Course in General Chemistry*, 2<sup>nd</sup> ed. (Boston: Ginn and Company, 1921): 343.

<sup>681</sup> McPherson and Henderson did not mention Bayley in connection with the Thomsen table. Whether or not they were aware of Bayley’s table is unknown. See *Course*, 337.

<sup>682</sup> Joel Hildebrand, *Principles of Chemistry* (New York: The Macmillan Company, 1918): 255, [https://hdl.handle.net/2027/uc1.\\$b277972](https://hdl.handle.net/2027/uc1.$b277972).

<sup>683</sup> Hildebrand, *Principles*, 256. It is interesting to note that Hildebrand did not refer to Bayley, only to Thomsen.

Three dimensions gave “a much more adequate representation of the periodic relationships.” Rather than the Harkins-Hall model, Hildebrand used a version (Fig. 7)<sup>684</sup> of Soddy’s helical representation, which greatly resembles William Crookes’s figure-of-eight model.<sup>685</sup> Hildebrand dropped the Soddy-inspired table in subsequent editions.

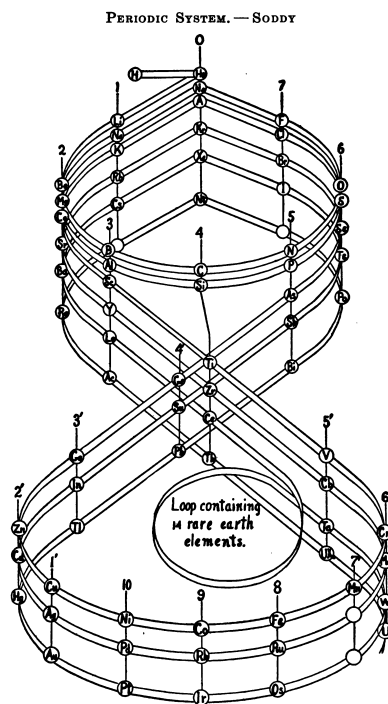

**Figure 5.7: Hildebrand’s version of Soddy’s Loop (1918)**

The many versions of the periodic table used in textbooks undoubtedly caused dismay and confusion on the part of students. Hildebrand noted, “It is far more important to become thoroughly familiar with one of the forms than it is to attempt to learn two or three of them with possible confusion.”<sup>686</sup> This was probably easier said than done as many textbooks did not have the same tables or

<sup>684</sup> Hildebrand, *Principles*, 259.

<sup>685</sup> Hildebrand, *Principles*, 257, table on 259.

<sup>686</sup> Hildebrand, *Principles*, 258.



had variations on similar forms, although most had a short form table despite its well-documented deficiencies. In a 1939 article, Laurence S. Foster, a professor of chemistry at Brown University, expressed his frustration:

But year after year the illogical and outmoded short form of the periodic table continues to reign. It seems to me that it is high time for some organization, such as the Division of Chemical Education of the American Chemical Society, to sponsor a simpler and more useful form of the table and to make an effort to induce textbook writers to adopt it as the standard type. Until the authors of secondary-school and college textbooks have been led to accept the modern periodic table, the readers will continue to be handicapped and confused in their thinking about the periodicity of chemical and physical properties.<sup>687</sup>

As was often the case when someone called for a new, easier to understand version of the periodic table, Foster had his own version of what he referred to as “the modern periodic table” (Fig. 8).<sup>688</sup>

TABLE 1.—THE PERIODIC ARRANGEMENT OF THE CHEMICAL ELEMENTS (with Atomic Numbers)

Period	Group Numbers																Inert Gases	
	1a	2a	3a	4a	5a	6a	7a	8	1b	2b	3b	4b	5b	6b	7b			
I 2 Elements	H 1															He 2		
II 8 Elements	Li 3	Be 4										B 5	C 6	N 7	O 8	F 9	Ne 10	
III 8 Elements	Na 11	Mg 12	Transitional Elements										Al 13	Si 14	P 15	S 16	Cl 17	A 18
IV 18 Elements	K 19	Ca 20	Sc 21	Ti 22	V 23	Cr 24	Mn 25	Fe 26	Co 27	Ni 28	Cu 29	Zn 30	Ga 31	Ge 32	As 33	Se 34	Br 35	Kr 36
V 18 Elements	Rb 37	Sr 38	Y 39	Zr 40	Cb 41	Mo 42	Ma 43	Ru 44	Rh 45	Pd 46	Ag 47	Cd 48	In 49	Sn 50	Sb 51	Te 52	I 53	Xe 54
VI 32 Elements	Cs 55	Ba 56	La <sup>58-70</sup> 57	Hf 72	Ta 73	W 74	Re 75	Os 76	Ir 77	Pt 78	Au 79	Hg 80	Tl 81	Pb 82	Bi 83	Po 84	— 85	Rn 86
VII 6 Elements	— 87	Ra 88	Ac 89	Th 90	Pa 91	U 92												

* Rare Earth Elements	Ce 58	Pr 59	Nd 60	II 61	Sm 62	Eu 63	Gd 64	Tb 65	Dy 66	Ho 67	Er 68	Tm 69	Yb 70
-----------------------	----------	----------	----------	----------	----------	----------	----------	----------	----------	----------	----------	----------	----------

**Figure 5.8: Foster’s Modern Table (1939)**

This modern table was “based upon atomic structure” and had been “available for a number of years.” Foster stated that “[c]redit may be assigned to no

<sup>687</sup> Laurence S. Foster, “Why Not Modernize the Textbooks Also? I. The Periodic Table,” *Journal of Chemical Education* 16 (1939): 410, doi:10.1021/ed016p409.

<sup>688</sup> Foster, “Why Not,” 410.

single person” for the modern table, although he asserted that it had “evolved directly from the *first form* of the periodic table” which Mendeleev had proposed in 1869 and that it was “closely related to the original *atomic volume* curve of Lothar Meyer.”<sup>689</sup> The use of the short form table before 1925 had been justified, Foster said, but the knowledge of atomic structure had advanced such that “the use of the longer form is practically obligatory.”<sup>690</sup> The continued use of the short form table in chemistry textbooks well into the 1950s illustrates how embedded it was in chemical culture.

### Deming’s Table

Among those who espoused opinions similar to those of Foster was Horace G. Deming. A professor of chemistry at the University of Nebraska, Deming published a textbook in 1923, *General Chemistry*. In the chapter on the periodic law, he provided two periodic tables, a short form and a long form. He referred to the short form as “Mendelejeff’s form, slightly modified,” as it had been updated with the most recent information concerning the elements, though it did not use atomic numbers. In the caption underneath this table, he wrote: “This table is due to Mendelejeff, the Russian chemist who first directed attention to many of the relationships we have traced between the elements. For this historical reason it is the one most commonly presented in text-books of chemistry, and the student should take pains to become familiar with it....”<sup>691</sup> Despite this assertion, Deming directed students instead to the

---

<sup>689</sup> Foster, “Why Not,” 410; emphasis in original.

<sup>690</sup> Foster, “Why Not,” 411.

<sup>691</sup> Horace G. Deming, *General Chemistry: An Elementary Survey Emphasizing Industrial Applications of Fundamental Principles* (New York: John Wiley & Sons, Inc., 1923): 165.

long form table he had developed, which was placed not only in the chapter on the periodic law but on the inside of the back cover, as well, for easy reference.

The reviews of Deming's textbook were generally positive. H. H. Lloyd wrote that it was "endowed with much of the freshness, enthusiasm and vision of its author" and that "no teacher of college chemistry should fail to give this text his careful consideration."<sup>692</sup> H. E. Cox, although regretting the "American style" of the book and the lack of English spelling, regarded it as "a very readable treatise in which general principles and applications of chemical science are clearly presented."<sup>693</sup> Although Arthur Smithells had some reservations, referring to the book as "somewhat disjointed and breathless," he did concede that "there is much in Prof. Deming's book that will be suggestive to chemical teachers, and that he has done especially good service in exhibiting the applications of chemistry to industry and other phases of human life."<sup>694</sup> The first edition of Deming's *General Chemistry*, in fact, was reprinted three times in less than two years.<sup>695</sup> The second edition swiftly followed the first, being published in 1925 to similarly good reviews. In a 1938 review of college-level general chemistry textbooks, Deming's *General Chemistry* was chosen as the exemplar for those published in 1923.<sup>696</sup> The text

---

<sup>692</sup> H. H. Lloyd, "General Chemistry," *Journal of Chemical Education* 2 (1925): 226, review of *General Chemistry*, by H. G. Deming, *Journal of Chemical Education* 2 (1925): 226, doi:10.1021/ed002p226.1.

<sup>693</sup> H. E. Cox, "General Chemistry," review of *General Chemistry*, by H. G. Deming, *Analyst* 49 (1924): 301-302.

<sup>694</sup> Arthur Smithells, "General Chemistry," review of *General Chemistry*, by H. G. Deming, *Chemistry and Industry* 43 (1924): 625.

<sup>695</sup> H. H. Lloyd, "General Chemistry," review of *General Chemistry*, by H. G. Deming, *Journal of Chemical Education* 3 (1926): 119. doi:10.1021/ed003p119.3.

<sup>696</sup> Ralph E. Dunbar, "Changing Conception of Teaching Helps in College General Chemistry Textbooks," *Journal of Chemical Education* 15 (1938): 336-339,

remained popular and the sixth and final edition was published in 1952, almost 30 years after the first.

None of the reviews mention Deming's long form periodic table, as would have been expected given its popularity and its spread. In a 1927 article promoting his own form of the periodic table, Royce H. LeRoy included "the Deming modification of Werner's table, this last being better known as the 'eighteen column' form" among the handful of "modifications best known at the present time." He stated that Deming's table represented "a very marked improvement over the original Mendeleef type as far as presentation to beginning classes is concerned."<sup>697</sup> Deming's table was distributed by Merck & Co. as part of a promotional campaign in 1928, printed on 8 ½ x 11" paper, and it continued to be distributed for several decades.<sup>698</sup> As one chemist wrote in 1987, "This gave it wide publicity, but clearly it met a need."<sup>699</sup> Deming's table was added to the *Handbook of Chemistry and Physics*

---

doi:10.1021/ed015p336. One of the teaching helps that Dunbar was looking for in his survey was the availability of the periodic table in the cover of the text; only 8 of the 25 books examined fulfilled this criteria (see p. 337).

<sup>697</sup> Royce H. LeRoy, "Teaching the Periodic Classification of Elements," *School Science and Mathematics* 27 (1927): 793.

<sup>698</sup> W. C. Fernelius and W. H. Powell, "Confusion in the Periodic Table of the Elements," *Journal of Chemical Education* 59 (1982): 506, doi:10.1021/ed059p504. In several archival collections I have found a 1949 periodic table distributed by Merck which is captioned "From *Fundamental Chemistry*, 2<sup>nd</sup> Edition, by H. G. Deming." According to Bernadette Bensaude-Vincent, the Welch Scientific Company also distributed Deming's table during the 1920s; see "Graphic Representations of the Periodic System of Chemical Elements," in U. Klein, ed., *Tools and Modes of Representation in the Laboratory Sciences* (Dordrecht: Kluwer Academic Publishers, 2001), 152.

<sup>699</sup> John Emsley, "The Development of the Periodic Table of the Chemical Elements," *Interdisciplinary Science Reviews* 12 (1987): 30.

in 1934<sup>700</sup> and to Lange's *Handbook of Chemistry* in 1944,<sup>701</sup> occurrences noteworthy enough to appear in the reviews of both of those volumes.

Deming's table has been considered the progenitor of the standard periodic table, having been specifically named by chemists involved in the IUPAC and by the historian Bernadette Bensaude-Vincent.<sup>702</sup> This long form table (Fig. 9),<sup>703</sup> looks very much like today's table, being composed of 18 columns and with the elements listed in order by atomic number. Boron and aluminum, as well as the noble gases, were originally placed on the left side of the table, being moved in the 4<sup>th</sup> edition (1935) to the right side where there are found today. In the 1923 table the rare earth elements were placed beneath the table, though not in the same fashion as today's tables; in fact, the placement of the rare earths, although always at the bottom of the table, was different in every edition and it was not until the 6<sup>th</sup> edition (1952) that they appeared in a separate series.<sup>704</sup> Likewise, hydrogen occupied a place in the center above the main body of the table until 1952 when it was moved to its now familiar location at the top of the first column on the left side.

---

<sup>700</sup> Otto Reinmuth, "Handbook of Chemistry and Physics," review of *Handbook of Chemistry and Physics*, edited by Charles D. Hodgman, *Journal of Chemical Education* 12 (1935): 50, doi:10.1021/ed012p50.4.

<sup>701</sup> Laurence S. Foster, "Handbook of Chemistry," review of *Handbook of Chemistry*, by Norbert A. Lange, *Journal of Chemical Education* 21 (1944): 520, doi:10.1021/ed021p520.2.

<sup>702</sup> Bensaude-Vincent describes Deming's textbook as "very influential," cites him as the source of the reversal of the A and B subgroups as used in the United States, and notes his table was "widely circulated"; see "Graphic Representations," 144, 151, 152.

<sup>703</sup> Deming, *General Chemistry*, front end paper.

<sup>704</sup> The lanthanides and actinides appear as they do on the standard table in the second edition of Deming's *Fundamental Chemistry: An Elementary Textbook for College Classes* (New York: John Wiley & Sons, Inc., 1947).

**THE PERIODIC TABLE**

O	IA R <sub>2</sub> O	IIA RO	IIIA R <sub>2</sub> O <sub>3</sub>	IVB RO <sub>2</sub>	VB R <sub>2</sub> O <sub>5</sub>	VIB RO <sub>3</sub>	VIIB R <sub>2</sub> O <sub>7</sub>	I	IB R <sub>2</sub> O	IIB RO	IIIB R <sub>2</sub> O <sub>3</sub>	IVA RO <sub>2</sub>	VA R <sub>2</sub> O <sub>5</sub>	VIA RO <sub>3</sub>	VIIA R <sub>2</sub> O <sub>7</sub>		
2 He 4.00	3 Li 6.94	4 Be 9.1	5 B 10.8	Arrows indicate directions of increasing basic properties. Sloping lines indicate the degree of relationship between Extreme Groups (A) and Intermediate Groups (B): greatest for Group IV, decreasing in both directions, and nearly disappearing with Groups I and VII.					6 C 12.005	7 N 14.008	8 O 16.000	9 F 18.9					
10 Ne 20.2	11 Na 23.00	12 Mg 24.32	13 Al 27.0	Transition Group Valence Variable					14 Si 28.1	15 P 31.04	16 S 32.06	17 Cl 35.46					
INERT GASES		METALS										HEAVY METALS		NON-METALS			
18 Ar 39.9	19 K 39.10	20 Ca 40.07	21 Sc 45.1	22 Ti 48.1	23 V 51.0	24 Cr 52.0	25 Mn 54.93	26 Fe 55.84	27 Co 58.97	28 Ni 58.68	29 Cu 63.57	30 Zn 65.37	31 Ga 70.1	32 Ge 72.5	33 As 74.96	34 Se 78.92	35 Br 79.92
36 Kr 83.8	37 Rb 85.45	38 Sr 87.63	39 Yt 88.93	40 Zr 90.6	41 Nb 93.1	42 Mo 96.0	43 Tc 99±	44 Ru 101.7	45 Rh 102.9	46 Pd 106.7	47 Ag 107.88	48 Cd 112.40	49 In 114.8	50 Sn 118.7	51 Sb 120.2	52 Te 127.5	53 I 126.92
54 Xe 131.2	55 Cs 132.81	56 Ba 137.37	Rare Earths 57-72 139-179		73 Ta 181.5	74 W 184.0	75 Re 186±	76 Os 190.9	77 Ir 193.1	78 Pt 195.2	79 Au 197.2	80 Hg 200.6	81 Tl 204.0	82 Pb 207.20	83 Bi 209	84 Po 210	85 At 210±
86 Rn 222.4	87 Fr 223±	88 Ra 226.0	89 Ac 227	90 Th 232.15	91 Pa 231	92 U 238.0	The rare earth elements are: 57 La 58 Ce 59 Pr 60 Nd 61 Pm 62 Sm 63 Eu 64 Gd 65 Tb 66 Dy 67 Ho 68 Er 69 Tm 70 Yb 71 Lu 72 Ct										

Valence Details:

**Figure 5.9: Deming's Periodic Table (1923)**

In a 1982 article, chemists W. C. Fernelius and W. H. Powell stated that Deming “included the pyramidal form of the periodic table used by Bohr” in his 1923 textbook.<sup>705</sup> At first glance this is puzzling as there is no obvious Bayley-Thomsen-Bohr table found in the text. However, turning Deming’s table on its side makes this observation clearer. Deming’s table includes lines from the 2<sup>nd</sup> and 3<sup>rd</sup> periods, which connect to the elements in the 4<sup>th</sup> through 7<sup>th</sup> periods. These lines correspond to those found in the Bayley-Thomsen-Bohr table. That table, however, places the 6<sup>th</sup> and 7<sup>th</sup> periods in a different configuration than in Deming’s table. There is, then, a connection between the two tables – one which, as Paneth noted, provides insight into atomic structure and its relationship to the periodic system.<sup>706</sup>

<sup>705</sup> Fernelius and Powell, “Confusion,” 505.

<sup>706</sup> These lines appear on the tables in Deming’s textbooks until after World War II. The 2<sup>nd</sup> edition (1947) of *Fundamental Chemistry* does not have the lines, nor does the 6<sup>th</sup> edition (1952) of *General Chemistry*, unlike all previous editions.

Another feature of Deming's table was the use of A and B labels at the top of the columns to differentiate between the major group elements and the transition elements. Deming was not the first to use A and B labels to designate these subgroups; Mendeleev also used these designators. However, Deming notably used A and B in the opposite manner of most other tables, especially those outside of the United States.<sup>707</sup> Ultimately, this caused some confusion in the chemical community, particularly after World War II when the United States began to play a more prominent role in chemical research and publication. This is why, in the early 1960s, the IUPAC's Commission for Nomenclature of Inorganic Chemistry (CNIC) attempted to make a change to the periodic table, which they ultimately dropped as being "too controversial."

### **The CNIC and the Periodic Table, Redux**

The CNIC had just sent the first edition of the Red Book to the publishers when the question was raised in December 1958 about subgroup labels A and B. One of the CNIC members wrote, "there seems to be a great confusion, and I think that our Commission should suggest which notation is to be adopted."<sup>708</sup> A subcommittee was formed to consider not only the A/B issue but also the terminology of other groups such as the lanthanides and actinides. K. A. Jensen prepared an extensive document in which he discussed the various forms of the periodic table and concluded, "According to the above discussion the most satisfactory – I should

---

<sup>707</sup> Fernelius and Powell, "Confusion," 505-506.

<sup>708</sup> L. Malatesta to Alexander Silverman, 11 December 1958, International Union of Pure and Applied Chemistry (IUPAC) Archive, Chemical Heritage Foundation, Philadelphia, Box 43, Folder 4.

even say the only satisfactory – periodic system is a slightly modified form of the old von Richter table.”<sup>709</sup> Victor von Richter’s table (Fig. 10)<sup>710</sup> was a short form table in which, as Jensen noted, the A and B subgroup labels are not used at all. In fact, Jensen believed that the use of A and B subgroups “have only a clear meaning when applied to the elements of the 18-periods.”<sup>711</sup>

*The Periodic System of the Elements.*

		I Group.	II Group.	III Group.	IV Group.	V Group.	VI Group.	VII Group.	VIII Group.		
H-Compounds. Highest salt-forming oxides.		— M <sub>2</sub> O	— MO	— M <sub>2</sub> O <sub>3</sub>	MH <sub>4</sub> MO <sub>2</sub>	MH <sub>5</sub> M <sub>2</sub> O <sub>5</sub>	MH <sub>2</sub> MO <sub>3</sub>	MH M <sub>2</sub> O <sub>7</sub>	MO <sub>3</sub>	MO <sub>2</sub>	(M <sub>2</sub> H) MO
Periods.	Series.	H 1 Li 7	Be 9	B 11	C 12	N 14	O 16	F 19			
1st	1st										
2d	2d	Na 23	Mg 24	Al 27	Si 28	P 31	S 32	Cl 35.4			
3d	{ 3d 4th	K 39 Cu 63	Ca 40 Zn 65	Sc 44 Ga 70	Ti 48 — 73	V 51 As 75	Cr 52 Se 79	Mn 55 Br 79.7	Fe 56	Co 58	Ni 58
4th	{ 5th 6th	Rb 85 Ag 108	Sr 87 Cd 112	Y 89 In 113	Zr 90 Sn 117	Nb 94 Sb 120	Mo 96 Te 126	— 100 I 126.5	Ru 104	Rh 104	Pd 106
5th	{ 7th 8th 9th 10th	Cs 133 — Au 197	Ba 137 — Hg 200	La 139 — Yb 173 Tl 204	(Ce 140 — — Pb 206	Di 142 — Ta 182 Bi 210	— — W 184 —	— — — —	Os(195)	Ir 193	Pt 195
					Th 232	—	Ur 240				

**Figure 5.10: Von Richter’s Table (1885)**

After much discussion of Jensen’s document, a table was recommended by the group and it was decided to “enquire privately whether this Table would be

<sup>709</sup> K. A. Jensen, “Nomenclature of Group Names etc.,” International Union of Pure and Applied Chemistry (IUPAC) Archive, Chemical Heritage Foundation, Philadelphia, Box 45, Folder 3. This conclusion is hardly surprising given that, as he admitted, Jensen used Von Richter’s table in his own general chemistry textbook (*Almen Kemi*).

<sup>710</sup> Victor von Richter, *A Text-Book of Inorganic Chemistry*, 2<sup>nd</sup> American ed. from the 4<sup>th</sup> German ed., trans. Edgar Fahs Smith (Philadelphia: P. Blakiston, Son & Co., 1885): 244, <https://books.google.com/books?id=7Q45AAAAMAAJ>.

<sup>711</sup> K. A. Jensen, “Nomenclature of Group Names etc.,” International Union of Pure and Applied Chemistry (IUPAC) Archive, Chemical Heritage Foundation, Philadelphia, Box 45, Folder 3.



acceptable by their National Nomenclature Committees.”<sup>712</sup> This was a wise decision as the reaction was probably not what they expected. The response of C. C. Addison was typical of the comments received from British chemists:

I have read these papers with a feeling little short of complete horror, and am distressed to find that Dr. Chatt should find the Mendeleev Table “quite acceptable”. ... The adoption of this form of Table, with all its consequent artificial problems, by the I.U.P.A.C. Committee would be such a serious blow to chemical education in this country that I would feel obliged to preach against it in public by every means possible.<sup>713</sup>

Addison also noted that the “extended form” (e.g., the modern 18-column form) was accepted by both secondary schools and colleges in Britain and a copy of it was on display in schools. Clearly what readers of the proposal focused on was the sample table, not on the nomenclature issues of various groups of the periodic system.

Joseph Chatt, the chair of the CNIC, noted he “would have liked to see the extended form used as an example to illustrate the nomenclature, but was voted down by the other members of the Sub-Commission who deemed the sample Table to include its extended form.”<sup>714</sup> The misstep with the sample table led the CNIC to table the issue of A and B subgroups.

---

<sup>712</sup> “Sub-Commission on the Nomenclature of Group Names, Minutes of a Meeting held in Elsinore on 1<sup>st</sup> July 1962 at 10.00 hrs.,” International Union of Pure and Applied Chemistry (IUPAC) Archive, Chemical Heritage Foundation, Philadelphia, Box 45, Folder 3.

<sup>713</sup> C. C. Addison to A. G. Sharpe, 4 March 1963, International Union of Pure and Applied Chemistry (IUPAC) Archive, Chemical Heritage Foundation, Philadelphia, Box 45, Folder 4.

<sup>714</sup> J. Chatt to A. G. Sharpe, 30 March 1963, International Union of Pure and Applied Chemistry (IUPAC) Archive, Chemical Heritage Foundation, Philadelphia, Box 45, Folder 4. Capitalizations as found in original.

In the second edition (1970) of the Red Book, the CNIC reiterated their stance on the European use of A and B subgroups. In response to a query as to their reasoning, Chatt stated:

As I understand the matter these were the sub-group designations which arose out of Mendeleev's original table and were in use throughout the World in the early part of this century. Some textbook writer in the United States either thought he could improve on the matter or simply got it wrong, probably I would guess around 1930. Unfortunately the Fischer *[sic]* Scientific Company copied that table onto its wall charts which became extensively used in the United States and also in England. In England students are usually told that the chart is wrong and in some Universities I have seen sticky labels with the correct sub-group numbering stuck over the Fischer *[sic]* numbers.<sup>715</sup>

Chatt did not name the American textbook writer, and he may not have known, but it was Deming.

The CNIC made another attempt to clarify the group number situation in the 1980s. This time, the blame for the A/B confusion was laid squarely at the feet of Deming rather than an unknown American textbook writer.<sup>716</sup> The CNIC sought to replace the group numbers with the Arabic numerals 1 through 18, thereby eliminating the need for the A/B subgroups.<sup>717</sup> The American Chemical Society (ACS) announced the change in group numbering in a brief article in its weekly

---

<sup>715</sup> Joseph Chatt to George Glaros, 6 March 1979, Addenda to the Records of the Union of Pure and Applied Chemistry, Chemical Heritage Foundation, Philadelphia, Box 109, Folder 4.

<sup>716</sup> Y. Jeannin to Kandace Whittlinger, 15 October 1982, Addenda to the Records of the Union of Pure and Applied Chemistry, Chemical Heritage Foundation, Philadelphia, Box 111, Folder 1.

<sup>717</sup> The group numbers 1 through 18 are now considered to be the official IUPAC recommendation and most published periodic tables follow this. Strangely enough, there are two periodic table wall charts in the lecture hall of the Integrated Sciences Building at the University of Massachusetts, Amherst, on which someone has taped A/B subgroup labels above the 1-18 group numbers.

news magazine. They noted, “measures are being undertaken to effect the change through chart and textbook publishers.” Also, the ACS had “found acceptable” a table drafted by the New York State Department of Education “for use in future curriculum development.”<sup>718</sup> Despite these assurances, the change provoked indignation from American chemists.

The Letters pages of *Chemical & Engineering News* were full of complaints for several months after the announcement. Robert F. Drake, a professor of chemistry at St. Mary’s College in Minnesota, spoke for many when he wrote, “it is certainly clear that no chemical educators were consulted” as “[t]he previous U.S. system is of pedagogical importance.” The changes were “one of those compromises in which chemical education in the U.S. loses – again. We have already abandoned the simplicity of the calorie and the atmosphere, for the reconditeness of the joule and the pascal, in the name of international accord.” He accused the ACS of “bend[ing] to the whims of the International Union of Pure & Applied Chemistry, which does not appear to care about education.”<sup>719</sup> Others were not so indignant. An educator with the New York state education department thought the change provided a teachable moment: “This is how science works: A system gets set up, like the old periodic table, and as people use it, they see it has problems, so they change it; hopefully, they improve it. This is an example of that process that students can understand.”<sup>720</sup>

---

<sup>718</sup> “Group Notation Revised in Periodic Table,” *Chemical & Engineering News* 63, no. 5 (1985): 27.

<sup>719</sup> “More on the Periodic Table,” *Chemical & Engineering News* 63, no. 11 (1985): 2.

<sup>720</sup> Rebecca Rawls, “Revisions to Periodic Table Spark Controversy,” *Chemical & Engineering News* 64, no. 4 (1986): 24.

As has always been the case, the discussion provided the opportunity to suggest other changes that could be made to the periodic table. Some made suggestions about the placement of specific elements within groups. A few suggested using instead a form they had created, although with the acknowledgment that no such change was likely to be made. R. T. Sanderson, echoing what had been a common complaint in the both the late nineteenth and early twentieth centuries regarding the short form table, noted, “Unhappily, the general apathy which has permitted acceptance of the current popular form for so many years despite its glaring and easily correctable faults will probably persist.”<sup>721</sup> He wasn’t wrong. In correspondence discussing disagreements with the various issues surrounding the change in group numbering, one American chemist noted about the 18-column table, “As far as I can recall, there has been little, if any, opposition to this mode of display. If anything, there is considerable support for it.”<sup>722</sup>

This seeming detour into the CNIC’s efforts to standardize group numbering on the periodic table illustrates several things about Deming’s 18-column table. As already noted, it became popular in the United States and was used in chemical handbooks, on wall charts, and in textbooks. It also was picked up in England and was firmly entrenched in chemical pedagogy by the early 1960s. The comments by

---

<sup>721</sup> R. T. Sanderson, “Woes With the Periodic Table,” *Chemical & Engineering News* 63, no. 10 (1985): 5.

<sup>722</sup> Paul Karol to Daryle H. Busch, 19 March 1987, Papers of Albert Ghiorso, Record Group 434: General Records of the Department of Energy, 1915-2007, National Archives and Records Administration–Pacific Region (San Francisco), Box 18, Folder 17.

Addison and other English chemical educators in response to the CNIC's sample table are an example of this. In 40 years, Deming's 18-column table had managed to replace the Mendeleev short form table in much of the world. And 65 years after Deming first published his table, one chemist could confidently state that Deming's table "gradually ousted all others until today it reigns supreme."<sup>723</sup>

### **The Death of the Short Form Table?**

The 18-column table may "reign supreme," but this is not to say that use of the Mendeleev table in chemical education died completely. In 1924, just after Deming published the first edition of his textbook, a new periodic table wall chart appeared in the United States. Published and distributed by the Welch Scientific Company, it was designed by Henry D. Hubbard, the first Secretary of the National Bureau of Standards. The Periodic Chart of the Atoms (Fig. 11)<sup>724</sup> was an updated version of the Mendeleev short table which included such information as electron shell configurations. The chart came with an accompanying booklet, the "Key to the Periodic Chart of the Atoms," which provided students with the knowledge necessary to understand the information found on the chart. It was also used in textbooks. Joseph A. Babor's *General Chemistry* (1929), for example, included the Periodic Chart inside the back cover though not in the text itself.<sup>725</sup> The Periodic Chart of the Atoms was extremely popular well into the 1950s.

---

<sup>723</sup> Emsley, "Development," 30.

<sup>724</sup> Henry D. Hubbard, *Primer of the Atoms: A Key to the Periodic Chart of the Atoms* (Chicago: W. M. Welch Manufacturing Company, 1937).

<sup>725</sup> Joseph A. Babor, *General Chemistry: A Text-Book for College Students* (New York: Thomas Y. Crowell Company, 1929).

**PERIODIC CHART OF THE ATOMS**  
Henry D. Hubbard

The Atoms Grouped According to the Number of Outer (Valence) Electrons

Planetary electrons in the completed orbits  
Atom No. = 2(1) 2(2) 2(3) 2(4) 1

Electronic	I								II		III		IV		V		VI		VII		VIII		IX		X		XI		XII		XIII		XIV		XV		XVI		XVII		XVIII	
1 H 1.0078																					He 4.002																					
2 Li 6.940	Be 9.02		B 10.82		C 12.01		N 14.008		O 16.0000		F 19.00		Ne 20.183								Ar 39.944																					
3 Na 22.997	Mg 24.32		Al 26.97		Si 28.06		P 31.02		S 32.06		Cl 35.457		Ar 39.944								Kr 83.7																					
4 K 39.096	Ca 40.08		Sc 45.10		Ti 47.90		V 50.95		Cr 52.01		Mn 54.93		Fe 55.84		Co 58.94		Ni 58.69				Zn 65.38																					
5 Rb 85.45	Sr 87.63		Y 88.92		Zr 91.22		Nb 92.91		Mo 95.94		Tc 98.906		Ru 101.07		Rh 102.91		Pd 106.7				Cd 112.41																					
6 Cs 132.91	Ba 137.36		La 138.92		Hf 178.6		Ta 180.88		W 184.0		Re 186.31		Os 193.1		Ir 193.22		Pt 195.23				Ag 107.868																					
7 Rn 222	Ra 226		Ac 227		Th 232		Pa 231		U 238.07												Au 197.2																					
*58-71 Rare Earths			Ce 140.13		Pr 140.92		Nd 144.27		Pm 146.91		Sm 150.43		Eu 152.0								Gd 156.9																					
			Tb 158.9		Dy 162.5		Ho 163.5		Er 167.3		Tm 168.9		Yb 173.0		Lu 175.0																											

W. M. Welch Manufacturing Company  
New Haven 10, Conn., U.S.A.

**Figure 5.11: Periodic Chart of the Atoms (1937)**

The CNIC surveyed usage of periodic table forms in the 1980s. They found that “Preferences for various formats ... have varied historically and still vary geographically.” The 18-column table was used in “most of Europe, both east and west, ... and this is also true of Japan and the United States.” In “Mendeleev’s homeland,” the short form table was “understandably highly favored” and was also “still widely used in Germany.” Overall the use of the 18-column table was common practice but “has been strongly challenged from quarters where cultural history supports retention of the traditional 8 column form.”<sup>726</sup>

<sup>726</sup> Daryle H. Busch to Kazuo Saito, [September 1986], Addenda to the Records of the Union of Pure and Applied Chemistry, Chemical Heritage Foundation, Philadelphia, Box 111, Folder 3.

PERIOD	ELECTRON SHELLS	GROUPS OF ELEMENTS								
		I	II	III	IV	V	VI	VII	VIII	
1	H <sup>1</sup> Hydrogen 1-0080									He <sup>2</sup> Helium 4-003
2	Li <sup>3</sup> Lithium 6-940	Be <sup>4</sup> Beryllium 9-013	B <sup>5</sup> Boron 10-81	C <sup>6</sup> Carbon 12-010	N <sup>7</sup> Nitrogen 14-008	O <sup>8</sup> Oxygen 16-000	F <sup>9</sup> Fluorine 18-998			Ne <sup>10</sup> Neon 20-183
3	Na <sup>11</sup> Sodium 22-989	Mg <sup>12</sup> Magnesium 24-31	Al <sup>13</sup> Aluminum 26-98	Si <sup>14</sup> Silicon 28-09	P <sup>15</sup> Phosphorus 30-973	S <sup>16</sup> Sulfur 32-066	Cl <sup>17</sup> Chlorine 35-453			Ar <sup>18</sup> Argon 39-944
4	K <sup>19</sup> Potassium 39-100	Ca <sup>20</sup> Calcium 40-08	Sc <sup>21</sup> Scandium 44-96	Ti <sup>22</sup> Titanium 47-88	V <sup>23</sup> Vanadium 50-93	Cr <sup>24</sup> Chromium 52-00	Mn <sup>25</sup> Manganese 54-93	Fe <sup>26</sup> Iron 55-85	Cu <sup>27</sup> Copper 63-54	Ni <sup>28</sup> Nickel 58-71
5	Rb <sup>37</sup> Rubidium 85-47	Sr <sup>38</sup> Strontium 87-63	Y <sup>39</sup> Yttrium 88-91	Zr <sup>40</sup> Zirconium 91-22	Nb <sup>41</sup> Niobium 92-91	Mo <sup>42</sup> Molybdenum 95-95	Tc <sup>43</sup> Technetium (99)	Ru <sup>44</sup> Ruthenium 101-07	Rh <sup>45</sup> Rhodium 102-91	Pd <sup>46</sup> Palladium 106-4
6	Cs <sup>55</sup> Cesium 132-91	Ba <sup>56</sup> Barium 137-36	La <sup>57</sup> Lanthanum 138-92	Hf <sup>58</sup> Hafnium 178-50	Ta <sup>59</sup> Tantalum 180-95	W <sup>60</sup> Tungsten 183-86	Rf <sup>61</sup> Rutherfordium 186-22	Os <sup>62</sup> Osmium 190-2	Ir <sup>63</sup> Iridium 193-1	Pt <sup>64</sup> Platinum 195-09
7	Fr <sup>87</sup> Francium (223)	Ra <sup>88</sup> Radium 226,04	Ac <sup>89</sup> Actinium (227)	(Th)	(Pa)	(U)				Rn <sup>86</sup> Radon 222
* LANTHANIDES										
Ce <sup>58</sup> Cerium 140-13	Pr <sup>59</sup> Praseodymium 140-92	Nd <sup>60</sup> Neodymium 144-27	Pm <sup>61</sup> Promethium (145)	Sm <sup>62</sup> Samarium 150-35	Eu <sup>63</sup> Europium 152-0	Gd <sup>64</sup> Gadolinium 157-26	Tb <sup>65</sup> Terbium 159-2	Dy <sup>66</sup> Dysprosium 162-51	Ho <sup>67</sup> Holmium 164-94	Er <sup>68</sup> Erbium 167-27
** ACTINIDES										
Th <sup>90</sup> Thorium 232-12	Pa <sup>91</sup> Protactinium 231	U <sup>92</sup> Uranium 238-07	Np <sup>93</sup> Neptunium [237]	Pu <sup>94</sup> Plutonium [242]	Am <sup>95</sup> Americium [243]	Cm <sup>96</sup> Curium [245]	Bk <sup>97</sup> Berkelium [247]	Cf <sup>98</sup> Californium [251]	Es <sup>99</sup> Einsteinium [252]	Fm <sup>100</sup> Fermium [257]

The atomic numbers of the most stable isotopes are given in square brackets.

Order of arrangement of electron shells

FIG. 1. Mendeleev's periodic table

**Figure 5.12: Russian Periodic Table (1963)**

One of those quarters was Germany, which did use both tables. The one country that consistently used the Mendeleev table was Russia. The tables found in twentieth century Russian textbooks show a short form table that had been updated to include the lanthanides and actinides at the bottom of the table, as they are in the standard table. Such tables are found in Boris Rosen's *In the Realm of Large Molecules* (1950s),<sup>727</sup> M. I. Korsunskii's *Atomic Nucleus* (1952),<sup>728</sup> D. N. Trifonov's

<sup>727</sup> B. Rosen, *In the Realm of Large Molecules* (Moscow: Foreign Languages Publishing House, [1958-1965]), 32-33; publication date range taken from the Harvard University Library catalog.

<sup>728</sup> M. I. Korsunskii, *Atomic Nucleus*, 4<sup>th</sup> ed. (Moscow: State Publishing House for Technical-Theoretical Literature, 1952), foldout at end of volume; I thank Philip Gerstein for his assistance in translating the bibliographic information for this book.

*The Rare-Earth Elements* (Fig. 12),<sup>729</sup> and N. L. Glinka's *General Chemistry* (1981).<sup>730</sup>

They were also on wall charts in universities, as seen in the photo of the chemist Ivo Zvara defending his dissertation at the State University in Moscow.<sup>731</sup> G. N. Flerov and Yuri Oganessian, heavy element researchers at the Joint Institute for Nuclear Research and discoverers of many new elements, were photographed in front of a Mendeleev table.<sup>732</sup>

Russian nationalism and the Soviet drive to illustrate their place at the forefront of science had naturally vaulted Mendeleev into the pantheon of Russian science. In a letter to the president of the IUPAC in response to the proposed changing of the group numbers on the periodic table, the chairman of the National Committee of Soviet Chemists wrote:

As compatriots of great creator of periodic table Dmitrii Mendeleev we feel it particularly important to keep table's traditional form, which has played the crucial role in the development of both chemistry and physics, and to reject all groundless attempts to renounce the generally accepted enclosed 8-groups form of periodic table which gives – inter alia – clear notion of the history of Mendeleev's discovery and origins of his thoughts.<sup>733</sup>

---

<sup>729</sup> D. N. Trifonov, *The Rare-Earth Elements* (New York: The MacMillan Company, 1963), foldout at end of volume.

<sup>730</sup> N. L. Glinka, *General Chemistry*, vol. 1, 3<sup>rd</sup> ed., trans. G. Leib (Moscow: Mir Publishers, 1981), front endpapers.

<sup>731</sup> Elaine Knorre, *A Visit to Transurania*, ed. H. C. Creighton; trans. M. Brodskaya (Moscow: Mir Publishers, 1974) (revised from the Russian original published 1971): 193.

<sup>732</sup> Photo found at [http://science-tv.jinr.ru/wp-content/uploads/2014/12/Photo\\_JINR\\_7.jpg](http://science-tv.jinr.ru/wp-content/uploads/2014/12/Photo_JINR_7.jpg).

<sup>733</sup> A. V. Fokin to C. N. R. Rao, June 1986, Addenda to the Records of the Union of Pure and Applied Chemistry, Chemical Heritage Foundation, Philadelphia, Box 111, Folder 4.



It is thus easy to explain the continued use of the short form table in Russia and even the lingering use of it in Germany, the “cultural homes of Mendeleev and Lothar Meyer.”<sup>734</sup>

The popularity of the short form Periodic Chart of the Atoms is not as easy to explain. One possibility is that the Chart was well designed. It appeared as an example of good graphic design in a book on graphic presentation. Hubbard penned an opening for the book titled “Magic in Graphs” in which he extolled the virtues of graphs of all kinds: “The graphic art depicts magnitudes to the eye. It does more. It compels the seeing of relations. ... Graphs serve as ... forceful engines of research for science, technology, and industry. They display results. They disclose new facts and laws. They reveal discoveries as the bud unfolds the flower.”<sup>735</sup> Just as a flower, the Periodic Chart of the Atoms was bright and colorful. The space for each element contained graphics depicting crystal structure, electron shells, magnetism, and much more – quite different from the 18-column table, which was rather drab in comparison. The Welch Scientific Company, which published the chart, updated it regularly – every two to three years – although, “Many schools continue to use these charts much longer than that, using them for schematic value rather than for current numerical value.”<sup>736</sup>

---

<sup>734</sup> Daryle H. Busch to Glenn T. Seaborg, 23 January 1987, Addenda to the Records of the Union of Pure and Applied Chemistry, Chemical Heritage Foundation, Philadelphia, Box 111, Folder 4.

<sup>735</sup> Henry D. Hubbard, “Magic in Graphs,” in Willard Cope Brinton, *Graphic Presentation* (New York: Brinton Associates, 1939): n.p., <https://archive.org/details/graphicpresentat00brinrich>.

<sup>736</sup> M. W. Welch to Glenn T. Seaborg, 10 February 1949, Box 850, Glenn Theodore Seaborg Papers, Manuscript Division, Library of Congress, Washington, D.C.

There were discussions about turning the Periodic Chart of the Atoms into a long form table. The Welch Company received several letters from chemists in 1947 asking about a long form. William E. Cadbury, a chemist at Haverford College, offered several reasons as to why “the ‘long form’ of periodic table might find a fairly large market,” including the fact that “elementary level” textbooks were “swinging more and more toward the long form” and that it was easier to follow the periods in that form.<sup>737</sup> Owens Hand Browne, at Lenoir Rhyne College, agreed, especially as “it has been shown that ... the trans-radium elements constitute a second series of the rare earths, it will be necessary to use a form that gives these elements their rightful place.”<sup>738</sup> In response, William F. Meggers, Chief of the Spectroscopy Division at the National Bureau of Standards, who became editor of the Periodic Chart when Hubbard retired, wrote:

I have been aware for many years that chemists prefer the long form but the compactness of the short form appealed to me. The scientific arguments are all in favor of the long form and it may be advisable in the future to abandon the old Mendelaeff plan and adopt the new Bohr plan. Perhaps we should be more progressive.<sup>739</sup>

It was not long before Meggers was willing to be “more progressive,” however M. W. Welch, the publisher, was reluctant. In 1952, he wrote, “I know no matter how

---

<sup>737</sup> William E. Cadbury, Jr. to Welch Manufacturing Company, 20 January 1947, Box 51, Folder 4, William F. Meggers Papers, Addition, 1870-1973. American Institute of Physics, Niels Bohr Library, College Park, MD

<sup>738</sup> Owens Hand Browne to Glenn Hobbs, 13 May 1947, Box 51, Folder 4, William F. Meggers Papers, Addition, 1870-1973. American Institute of Physics, Niels Bohr Library, College Park, MD. It should be noted that Browne had designed his own long form table; see Owens Hand Browne, “The Problem of the Periodic System,” *The Science Teacher* 19 (1952): 271-273, <http://www.jstor.org/stable/24154395>.

<sup>739</sup> William F. Meggers to Glenn M. Hobbs, 27 January 1947, Box 51, Folder 4, William F. Meggers Papers, Addition, 1870-1973. American Institute of Physics, Niels Bohr Library, College Park, MD.

much better the new material is, there will be a great many teachers who will demand the old Mendelleff form of chart in spite of all of our advertising, for a considerable time to come.”<sup>740</sup> In the following years, Welch expressed the desire several times to meet with Meggers to discuss a long form chart, however such a version of the Periodic Chart of the Atoms was never commercially produced.<sup>741</sup>

### **The Standard Periodic Table of the Elements**

Why did the 18-column table come to “reign supreme” in most of the world? As LeRoy noted, Deming’s table was an improvement over the Mendeleev table in terms of presentation to beginning students. Merck distributed copies on standard letter size paper, so it could fit neatly onto a page and still be easily usable. Heavy black lines clearly demarcated the different types of elements: inert gases, non-metals, heavy metals, light metals, and rare earths. Beginning with the 1925 edition, Deming “effectively” showed electron orbits.<sup>742</sup> For chemical educators, the 18-column table met most of their pedagogical needs. It adequately presented both basic chemical and physical information about the elements and their relationships. It fit neatly onto a page, whether that be in a notebook or textbook. And it appeared at an opportune time. As historian Bernadette Bensaude-Vincent noted, by the 1930s the function of the periodic system was undergoing a shift. “Rather than as

---

<sup>740</sup> M. W. Welch to William F. Meggers, 2 June 1952, Box 52, Folder 1, William F. Meggers Papers, Addition, 1870-1973. American Institute of Physics, Niels Bohr Library, College Park, MD.

<sup>741</sup> The short form Periodic Chart is still available for purchase from Sargent Welch, although it is only one of several different periodic tables they sell and the only one that is not an 18 column table.

<sup>742</sup> G. N. Quam and Mary Battell Quam, “Types of Graphic Classifications of the Elements,” *Journal of Chemical Education* 11 (1934): 222, doi:10.1021/ed011p217.

an adequate representation of a law of nature, it was more and more considered as a teaching device. Compact simplicity took over for accuracy.”<sup>743</sup>

This change in function can be seen in chemistry textbooks over the course of the twentieth century. In the first half of the century, textbooks generally gave four uses for the periodic table: the classification of the elements, the prediction of new elements, the correction of atomic weights, and the stimulation of research (i.e., the discovery of new elements). Sometimes these uses were compressed into three or expanded into five, but they were all generally present. This began to change in the second half of the twentieth century. In the first edition (1957) of their popular text *General College Chemistry*, Jesse Hermon Wood and Charles William Keenan stated that the periodic table was useful for the prediction of new elements. But in a section titled “Present Usefulness,” they provide two uses for the periodic table: “an aid in memorizing and understanding chemical data” and “a guide to chemical prediction and theory.”<sup>744</sup> In the 6<sup>th</sup> edition, published 23 years later, they noted, “The periodic table was marvelously useful to all those who studied atomic structure early in this century,” but for contemporary consideration they reiterated the same two uses given in previous editions – an aid to remembering and a guide to determining which elements are similar to each other.<sup>745</sup>

---

<sup>743</sup> Bernadette Bensaude-Vincent, “Graphic Representations of the Periodic System of Chemical Elements,” in U. Klein, ed., *Tools and Modes of Representation in the Laboratory Sciences* (Dordrecht: Kluwer Academic Publishers, 2001): 144.

<sup>744</sup> Jesse Hermon Wood and Charles William Keenan, *General College Chemistry* (New York: Harper & Brothers, Publishers, 1957): 285-286.

<sup>745</sup> Charles W. Keenan, Donald C. Kleinfelter, and Jesse H. Wood, *General College Chemistry*, 6<sup>th</sup> ed. (San Francisco: Harper & Row, Publishers, 1980): 88.

In the twenty-first century, many textbooks no longer have sections on the usefulness of the periodic table. Rather, students are offered a sentence or two. In the 9<sup>th</sup> edition (2003) of the popular text *Chemistry: The Central Science*, the authors stated: “The Periodic Table is the most significant tool that chemists use for organizing and remembering chemical facts.”<sup>746</sup> Raymond Chang and Jason Overby were not quite as succinct in providing a similar statement: “The importance and usefulness of the periodic table lie in the fact that we can use our understanding of the general properties and trends within a group or a period to predict with considerable accuracy the properties of any element, even though that element may be unfamiliar to us.”<sup>747</sup> Rarely is there any mention of the historic (and current) research uses of the periodic table. This may be part of the trend that has eliminated history from science textbooks, but it also may be a function of the way in which many chemists view the periodic table.

In a 2016 article in *Nature* spurred by the official announcement of the discovery of elements 113, 115, 117, and 118, the science writer Philip Ball presented some thoughts about the periodic table and its role in chemistry:

A deeper issue is what popular interest in the new elements implies about the status of the periodic table itself. Its systematization of elements has made it an icon for chemistry as a whole. Yet chemists rarely need to refer to it, and most of them work with just a handful of the more common elements. It is fair to say that the periodic table holds more interest and glamour for the public than it does for the working chemist.<sup>748</sup>

---

<sup>746</sup> Theodore L. Brown, et al., *Chemistry: The Central Science*, 9<sup>th</sup> ed. (Upper Saddle River: Pearson Education, Inc., 2003): 237.

<sup>747</sup> Raymond Chang and Jason Overby, *General Chemistry: The Essential Concepts*, 6<sup>th</sup> ed. (New York: McGraw-Hill, 2011): 253.

<sup>748</sup> Philip Ball, “New Chemistry Revives Elementary Question,” *Nature* 529 (2016): 129, doi:10.1038/529129a.

Ball's article elicited few comments on the *Nature* web site and the majority of those had to do with the naming of the new elements. The only comment that referred to the periodic table was from a retired chemist who simply wrote, "I disagree that chemists rarely even look at the periodic table. It defines much of further research, exploring its profundities."<sup>749</sup>

Eric Scerri, via social media, disagreed with Ball's comments on the periodic table. In response to Scerri's tweets, Ball wrote a blog post expanding on what he meant: "These statements are too general; I should say 'many' (most?) chemists. There are some who surely do use it, and a rather small group of others – Eric among them, of course – who expend a lot of time and thought on the right way to structure it."<sup>750</sup> In the comments on the post, Scerri also elaborated on his statements, writing, "Admittedly not every Inorganic chemistry [sic] uses the periodic table each and every day in the same way that they use their computer say but still the periodic system/table forms the backdrop against [which] all research is being conducted."<sup>751</sup> Ball echoed this idea in his response: "But I do think that, for plenty of chemists, it is important only in much the same sense that the standard model is important in physics: important in the sense that the bricks of a theatre are important for the performance taking place on stage."

---

<sup>749</sup> Robert Buntrock, comment on Philip Ball, "New Chemistry Revives Elementary Question," 12 January 2016, *Nature*, <http://www.nature.com/news/new-chemistry-revives-elementary-question-1.19145>.

<sup>750</sup> Philip Ball, "The Place of the Periodic Table," *homunculus*, 12 January 2016, <http://philipball.blogspot.com/2016/01/the-place-of-periodic-table.html>.

<sup>751</sup> Eric Scerri, comment on Philip Ball, "The Place of the Periodic Table," *homunculus*, 12 January 2016, <http://philipball.blogspot.com/2016/01/the-place-of-periodic-table.html>.

These comments, I think, place the periodic table as something fundamental to chemistry. Just as grammar and vocabulary are something we learn in school but mostly cease to think about as adults, the periodic table is something chemists learn in school and rarely actively think about in practice. It is the background, the basic knowledge, the handy tool, necessary for chemists to do their work, whatever that may be. In the eyes of the public, the standard periodic table is a symbol of chemistry, if not of science as a whole. But for chemists, the periodic table, whether an 18-column standard form or one of a thousand other forms, remains as Carnelley described it in 1879, “the finger-post of chemical science,” pointing users in the direction they need to go to understand the elements – but no longer as important a guidepost for venturing further down the road in research.

\*\*\*\*\*

The development of the periodic table was – and continues to be – a collective endeavor, one in which the role of chemical pedagogy has been underappreciated. As this chapter has shown, international chemical organizations have had an effect on the elements – defining them, regularly redetermining their atomic weights, and naming new ones – but they have had little effect on the form of the periodic table. The seeming attempts of the IUPAC in the second half of the twentieth century to mandate the use of a specific form of the table were met with such outrage from chemical educators that they decided it was too controversial to dictate the use of any specific form. W. Conard Fernelius, a chemist with a passion for education and nomenclature, and a long-time member of the IUPAC’s Commission on Nomenclature of Inorganic Chemistry, wrote in the *Journal of*

*Chemical Education*, “the choice of one form of the periodic table as the ‘official’ or the ‘best’ is a mistake. Users of the periodic table should be encouraged to know several forms and to use that one that best suits the use at hand.”<sup>752</sup>

Long before Mendeleev began his own education in chemistry, chemical educators were searching for new and better ways to classify the elements for the purpose of the lecture hall, to ease the confusion of their students. And even after the discovery of the periodic law, chemical educators – Mendeleev included – continued to develop and improve the system and its graphical representation. Irwin Cohen, a professor chemistry at the time the IUPAC relabeled the groups on the 18-column table, noted, “The periodic table has never been one, and only one, design, but rather a loose set of many different ways (circular, triangular, helical) for expressing important relations. It would be a shame to give that up.”<sup>753</sup>

Chemical educators continue to design new forms of the periodic table, but they understand the necessity of having a standard form for use in textbooks and in the classroom. Confusion would once again abound if this standard table were to be replaced by the free-for-all that existed up to the middle of the twentieth century. In this era of globalization and standardized education at almost every level of the curriculum, confusion is not an option. The 18-column form that is the current standard periodic table will likely continue to “reign supreme” in textbooks and on wall charts – unless there is another discovery that radically changes our

---

<sup>752</sup> W. Conard Ferneliuss, “Some Reflections on the Periodic Table and Its Use,” *Journal of Chemical Education* 63 (1986): 266, doi:10.1021/ed063p263.

<sup>753</sup> Irwin Cohen, “Design of the Periodic Table,” *Chemical & Engineering News* 63, no. 8 (1985): 4.



understanding of the elements and renders that form unsuitable for educating the next generation of students.

**CHAPTER 6**  
**CONCLUSION:**

**THE “DYNAMIC AND CHANGING” PERIODIC TABLE**

**The Current Standard Form of the Periodic Table**

A surprising Internet sensation is the Periodic Table of Videos (PTOV).<sup>754</sup> Originally meant to be a short term project between the chemistry department at the University of Nottingham and filmmaker Brady Haran, the PTOV is still going strong eight years later. The star of the video series is The Prof, Martyn Poliakoff, a chemist at Nottingham. At a recent meeting, he mused that “my first inorganic chemistry textbook did not include a periodic table at all. Like many of my contemporaries, I bought one which I proudly hung on my bedroom wall and still have in my office more than 50 years later.” Still entranced by the periodic table, he has adopted it as his “badge of office” and wears a periodic table tie in his role as the Foreign Secretary of the Royal Society. Reflecting on his role in the PTOV, he noted that chemists have become “increasingly focused and limited to their own particular area of chemistry” and he has been able to explore other parts of chemistry because of the videos. He has also discovered “how many people of all ages and walks of life are genuinely fascinated by the periodic table,” not only sending messages and questions but stopping him in public places. Poliakoff has also found it “surprising” to discover “how dynamic and changing the periodic table has been” in recent years,

---

<sup>754</sup> “Periodic Table of Videos,” <http://www.periodicvideos.com/>.

with the addition of new elements and the continuing search for superheavy elements of ever higher atomic number.<sup>755</sup>

One of the aspects of the periodic table that is rarely discussed in the PTOV are its many different graphical representations.<sup>756</sup> Even here, on a site that celebrates the periodic table and the elements, the current standard form is taken for granted. Despite the many papers and books written about the periodic table, few have addressed the issue of how and why this current form exists. How did it come to “reign supreme” over other forms? This dissertation provides an answer to that question. Namely, that chemical educators, enthusiastically embraced the periodic system and made it integral to pedagogy, continuing to create new forms of the periodic table long after the periodic law had been accepted and provided with a firm theoretical base. Eventually, the number of graphic visualizations of the periodic system being used caused confusion among students and educators. Over time, a standard form was adopted for use in textbooks and classrooms. In short, it was chemical educators not researchers who spurred the development of the current standard form of the periodic table.

This is not to say that chemical classification in general and the periodic system in particular have not been of great utility to chemical researchers. As shown in Chapter 2, one of the great research questions of the nineteenth century

---

<sup>755</sup> Martyn Poliakoff and Samantha Tang, “The Periodic Table: Icon and Inspiration,” *Philosophical Transactions of the Royal Society A* 373 (2016): 20140211, doi:10.1098/rsta.2014.0211.

<sup>756</sup> There is one video about an early short form table ([http://www.periodicvideos.com/videos/old\\_periodic\\_table.htm](http://www.periodicvideos.com/videos/old_periodic_table.htm)) and one about a Periodic Chart of the Atoms The Prof found in a lecture hall in Brazil ([http://www.periodicvideos.com/videos/feature\\_brazil\\_table.htm](http://www.periodicvideos.com/videos/feature_brazil_table.htm)).

was the development of a classification system that encompassed all of the elements. This search was characterized by the search for ways to further refine the determination of atomic weight, considered to be an important characteristic of the elements for the creation of such a system. Chapter 3 demonstrated the crucial role of research in the acceptance and continued development of the periodic system during the last decades of the nineteenth century. It was through this process that chemists felt for a “middle ground” between empirical evidence and the utility of theory, continuing to evolve from a science that relied on the senses in its investigation of the elements.

In the final years of the nineteenth century and in the first decades of the twentieth, the periodic system turned from an object of research into a tool of research. Chapter 4 illustrated how both physicists and chemists utilized the periodic table in their search to explore the structure of atoms and to explain the “invisible chemistry” of radioactivity. In the process, chemists’s understanding of the elements changed dramatically. Yet by the start of World War I the periodic system was bolstered, having been provided with a firm theoretical foundation and the table becoming organized by atomic number rather than by atomic weight. In the era of internationalism, chemists came together to standardize their science. The International Union of Pure and Applied Chemistry (IUPAC), the international standards making body for chemistry, became the caretaker of the periodic table, in charge of determining atomic weights and naming newly discovered elements.

But as Chapter 5 established, the IUPAC had little effect on the form of the periodic table. Any change that was seen as an attempt to mandate the use of a

specific form was met with cries of outrage from chemical educators. In the years following World War II, the current standard form had become so entrenched in chemical pedagogy that educators found such attempts contemptible – especially coming from a non-pedagogical body. Many decided the IUPAC had little or no regard for chemical education.<sup>757</sup> The current standard form developed, over the course of several decades, from a table created by a chemical educator. Horace G. Deming's table proved popular enough to appear in chemical handbooks and to be given away and sold by scientific supply companies, furthering its spread beyond the venue of his popular textbooks.

By the time Deming's table first appeared in 1923, there was a plethora of visual representations of the periodic table to be found in chemical textbooks and on the walls of chemistry lecture halls. This proliferation of tables was not unique to the early twentieth century. As shown in Chapter 2, during the first decades of the nineteenth century chemical educators as well as researchers were looking for better ways to organize the elements for the sake of their students. They developed their own classifications, often with visual representations, for use in their classrooms. As substantiated in Chapters 3 and 4, chemical educators were quick to incorporate the periodic system into pedagogy. They organized their courses and textbooks around it. And they frequently developed new visual representations of it for the use of their students. Mendeleev's table had several deficiencies and educators were keen to find ways to fix it, even if those fixes came in very different

---

<sup>757</sup> The IUPAC does, in fact, have an active Committee on Chemical Education.

forms. Eventually, all of those attempts created confusion for students and a standard form was deemed necessary.

### **Areas for Further Research**

This dissertation has done much to answer the question of how and why a standard form of the periodic table was created, but there are always more questions to be answered. Several areas only briefly touched on in this dissertation are deserving of further research. One of these is wall charts. As shown in this dissertation, chemical educators found a variety of ways to produce and use wall charts in their lecture halls. The use of visual representations in the lecture hall was undoubtedly a vital component of chemical pedagogy. Long before the appearance of commercially produced wall charts, educators across the sciences were putting up sheets and large pieces of paper on stands with hand drawn charts, tables, and other visual representations to illustrate theories, structures, and formulae. Commercial production began in the late nineteenth century but, as far as I know, this has not been much studied.

A related area of research is the influence of commercial entities on the periodic table. Scientific supply companies were instrumental in spreading Deming's table across the United States and into Europe and probably even further. As John Rudolph showed in his study of 1960s biological educational supplies, these companies had a great influence on what educators purchased for use in their schools and universities. Clearly, as the case of the Periodic Chart of the Atoms shows, alternate forms of the periodic table were popular amongst educators well past the time when the current standard form had usurped most others in

textbooks. How many other forms of the table for available for purchase and when? Who made the decision to produce and sell these wall charts?

The role of textbook publishers is also important. Most chemical textbooks are not published by scientific publishers but by general education publishers. As Antonio García-Belmar, José Ramón Bertomeu-Sánchez, and Bernadette Bensaude-Vincent noted, these publishers are subject to technical, financial, and political constraints that likely have little to do with science.<sup>758</sup> Changes in educational trends and national and/or local education policies, amongst other things, affect the content of textbooks and how that content is portrayed. Was it textbook publishers who decided who would author a text? Or did educators approach the publishers? How much did publishers affect the content of chemistry textbooks or the use of illustrations, such as a periodic table? It would be beneficial to consider the history of education and the history of books more broadly in conjunction with the history of the periodic table to determine how much those areas influenced the development of a standard form of the table.

The role played by handbooks in the spread of Deming's table is also an area of interest. The role of handbooks in the codification and diffusion of knowledge has not been widely examined. In their study of handbooks in the field of science and technology studies, Stasa Milojevic, Cassidy R. Sugimoto, Vincent Larivière, Mike Thelwall, and Ying Ding found that handbooks played different roles than did

---

<sup>758</sup> Antonio García-Belmar, José Ramón Bertomeu-Sánchez, and Bernadette Bensaude-Vincent, "The Power of Didactic Writings: French Chemistry Textbooks of the Nineteenth Century," in *Pedagogy and the Practice of Science: Historical and Contemporary Perspectives*, ed. David Kaiser (Cambridge: The MIT Press, 2005), 222.

journals in the creation and spread of knowledge. Handbooks have an educational function, serving to keep both internal and external audiences up to date. Handbooks differ from textbooks, however, serving a different purpose and often being written by many authors at the behest of an editorial board.<sup>759</sup> As briefly mentioned in Chapter 5, Deming's table was the first to be included in two influential chemical handbooks. Why was his table chosen? Why had they not previously included a periodic table? How many chemical handbooks had included periodic tables before these two?

These questions may not be easy to answer – if it is even possible to answer some of them – and they are beyond the scope of what I have done in this dissertation. The science behind the periodic law has largely been explored. In this dissertation I have shown the integral role played by chemical educators in the continued development of graphic representations of the periodic system and in the creation of a standard form of the periodic table. But the relationship of the periodic table with the larger histories of education and publishing is an area still to be explored. The history of the periodic table, as The Prof noted about the periodic table itself, continues to be “dynamic and changing.”

---

<sup>759</sup> Stasa Milojevic, Cassidy R. Sugimoto, Vincent Larivière, Mike Thelwall, and Ying Ding, “The Role of Handbooks in Knowledge Creation and Diffusion: A Case of Science and Technology Studies,” *Journal of Informetrics* 8 (2014): 706, doi:10.1016/j.joi.2014.06.003.



## BIBLIOGRAPHY

### Archives & Special Collections

Boltwood, Bertram Bordon. Papers. Manuscripts and Archives, Yale University Library, New Haven, CT.

Ghiorso, Albert. Papers. National Archives and Records Administration–Pacific Region, San Francisco, CA.

Hartley, Clara Esther. Laboratory Notes. Chemical Heritage Foundation, Philadelphia, PA.

Historical Textbooks Collection. Monroe C. Gutman Library, Graduate School of Education, Harvard University, Cambridge, MA.

International Union of Pure and Applied Chemistry (IUPAC). Archive. Chemical Heritage Foundation, Philadelphia, PA.

Mazurs, Edward G. Collection of Periodic Systems. Chemical Heritage Foundation, Philadelphia, PA.

Meggers, William F. Papers, Addition, 1870-1973. Niels Bohr Library, American Institute of Physics, College Park, MD.

Ontario Textbook Collection. OISE Library, Ontario Institute for Studies in Education, University of Toronto, Toronto, ON.

Seaborg, Glenn Theodore. Papers. Manuscript Division, Library of Congress, Washington, D.C.

Stedman, Donald Frank. Fonds. Library and Archives Canada, Ottawa, ON.

Union of Pure and Applied Chemistry. Addenda to the Records. Chemical Heritage Foundation, Philadelphia, PA.

Winterhouse Chemistry Collection. Medical History Library, Harvey Cushing/John Hay Whitney Medical Library, Yale University, New Haven, CT.

### Books and Articles

Abubakr, Mohd. "An Alternate Graphical Representation of Periodic Table of Chemical Elements." arXiv:0910.0273 [physics.gen-ph].  
<https://arxiv.org/abs/0910.0273>.

Adams, Elliott Quincy. "A Modification of the Periodic Table." *Journal of the American Chemical Society* 33 (1911): 684-688. doi:10.1021/ja02218a004.

Angus, W. Rogie. "University College of North Wales, Bangor." *Journal of the Royal Institute of Chemistry* 78 (1954): 291-298.

"Anniversary Meeting." *Proceedings of the Royal Society of London* 34 (1882-1883): 301-342. <http://www.jstor.org/stable/113999>.

"Anniversary Meeting." *Proceedings of the Royal Society of London* 43 (1887-1888): 184-210. <http://www.jstor.org/stable/114532>.

Arabatzis, Theodore, and Kostas Gavroglu. "The Chemists' Electron." *European Journal of Physics* 18 (1997): 150-163. doi:10.1088/0143-0807/18/3/005.

"Argon." *Nature* 51 (1895): 337-338. doi:10.1038/051337a0.

Armstrong, [Henry E.], Raphael Meldola, and F. H. Butler. "Chemistry." In *The Encyclopaedia Britannica*. Original Ninth Edition in Twenty-Five Volumes, In Thirty Volumes With New American Supplement, 5:459-579. New York: The Werner Company, 1902.

<https://hdl.handle.net/2027/uc2.ark:/13960/t6tx3m15n?urlappend=%3Bseq=471>

Armstrong, Henry E. "The Classification of the Elements." *Proceedings of the Royal Society of London* 70 (1902): 86-94. <http://www.jstor.org/stable/116601>.

Armstrong, Henry E. "The Nature of Chemical Change." *Chemical News* 99 (1909): 28-30, 37-38.

<https://hdl.handle.net/2027/mdp.39015073139308?urlappend=%3Bseq=34>.

Armstrong, H. E. "Presidential Address." In *Report of the Seventy-Ninth Meeting of the British Association for the Advancement of Science*, 420-454. London: John Murray, 1910. <https://biodiversitylibrary.org/page/29718613>.

Armstrong, Henry E. "Radium." *Times* (London). August 10, 1906: 6.

Aston, F. W. *Isotopes*. London: Edward Arnold & Co., 1922.

<https://archive.org/details/isotopes00asto>.

Aston, F. W. "Mass-Spectra and the Atomic Weights of the Elements." *Science Progress in the Twentieth Century* 15 (1920): 212-222.

<https://hdl.handle.net/2027/njp.32101076203833?urlappend=%3Bseq=226>.

Aston, F. W., Gregory P. Baxter, Bohuslav Brauner, A. Debierne, A. Leduc, T. W. Richards, Frederick Soddy, and G. Urbain. "Report of the International Committee on Chemical Elements, 1923." *Journal of the American Chemical Society* 45 (1923): 867-874. doi:10.1021/ja01657a001.

Auer v. Welsbach, Carl. "Die Zerlegung des Didyms in seine Elemente." *Monatshefte für Chemie* 6 (1885): 477-491.  
<https://hdl.handle.net/2027/uc1.b3483664?urlappend=%3Bseq=493>.

Babor, Joseph A. *General Chemistry: A Text-Book for College Students*. New York: Thomas Y. Crowell Company, 1929.

Badash, Lawrence. "Radioactivity Before the Curies." *American Journal of Physics* 33 (1965): 128-135. doi:10.1119/1.1971267.

Badash, Lawrence. *Radioactivity in America: Growth and Decay of a Science*. Baltimore: Johns Hopkins University Press, 1979.

Badash, Lawrence, ed. *Rutherford and Boltwood: Letters on Radioactivity*. New Haven: Yale University Press, 1969.

Badash, Lawrence. "Rutherford, Boltwood, and the Age of the Earth: The Origin of Radioactive Dating Techniques." *Proceedings of the American Philosophical Society* 112 (1968): 157-169. <http://www.jstor.org/stable/986161>.

Bagnall, K. W. "Polonium." *Endeavour* 22 (1963): 61-64.

Baldwin, Simeon E. "The International Congresses and Conferences of the Last Century as Forces Working Toward the Solidarity of the World." *American Journal of International Law* 1 (1907): 565-578, 808-829.  
<http://www.jstor.org/stable/2186820>, <http://www.jstor.org/stable/2186845>.

Ball, Philip. "New Chemistry Revives Elementary Question." *Nature* 529 (2016): 129. doi:10.1038/529129a.

Bassett, Henry. "A Tabular Expression of the Periodic Relations of the Elements." *Chemical News* 65 (1892): 3-4, 19.  
<https://hdl.handle.net/2027/nnc1.cu09484205?urlappend=%3Bseq=11>.

Baumhauer, Heinr. *Die Beziehungen Zwischen dem Atomgewichte und der Natur der Chemischen Elemente*. Braunschweig: Friedrich Vieweg und Sohn, 1870.  
[https://books.google.com/books?id=yQw\\_AAAAYAAJ](https://books.google.com/books?id=yQw_AAAAYAAJ).

Bayley, Thomas. "On the Connexion Between the Atomic Weight and the Chemical and Physical Properties of Elements." *Philosophical Magazine*, 5<sup>th</sup> ser., 13 (1882): 26-37. <https://hdl.handle.net/2027/hvd.32044036926350?urlappend=%3Bseq=42>.

Bazarov, A. "Ob atomnykh vesakh elementov." *Zhurnal Russkogo Khimicheskogo Obshchestva* 19 (1887): 61-73.  
[https://hdl.handle.net/2027/uc1.\\$b625247?urlappend=%3Bseq=203](https://hdl.handle.net/2027/uc1.$b625247?urlappend=%3Bseq=203).

Bedson, P. Phillips. "Lothar Meyer Memorial Lecture." In *Memorial Lectures Delivered Before the Chemical Society, 1893-1900*, 1403-1439. London: Gurney and Jackson, 1901. <https://books.google.com/books?id=MYFFAQAAIAAJ>.

Béguyer de Chancourtois. "Mémoire sur un classement naturel des corps simple ou radicaux appelé *vis tellurique*." *Comptes Rendus Hebdomadaires des Séances de l'Académie des Sciences* 54 (1862): 757-761.  
<https://hdl.handle.net/2027/uc1.31822009518911?urlappend=%3Bseq=763>.

Béguyer de Chancourtois. "Suite du Mémoire de la vis tellurique, du 7 avril 1860, adressé à propos du thallium." *Comptes Rendus Hebdomadaires des Séances de l'Académie des Sciences* 56 (1863): 479-482.  
<https://hdl.handle.net/2027/uc1.c080928393?urlappend=%3Bseq=483>.

Béguyer de Chancourtois. "Sur un classement des corps simples ou radicaux appelé *vis tellurique*: addition au Mémoire présenté à la séance du 7 avril." *Comptes Rendus Hebdomadaires des Séances de l'Académie des Sciences* 54 (1862): 840-843.  
<https://hdl.handle.net/2027/uc1.31822009518911?urlappend=%3Bseq=846>.

Béguyer de Chancourtois. "Sur un classement des corps simples ou radicaux appelé *vis tellurique* – Addition au Mémoire présenté à la séance du 7 avril." *Comptes Rendus Hebdomadaires des Séances de l'Académie des Sciences* 54 (1862): 967-971.  
<https://hdl.handle.net/2027/uc1.31822009518911?urlappend=%3Bseq=973>.

Béguyer de Chancourtois. "Tableau du classement naturel des corps simples, dit vis tellurique." *Comptes Rendus Hebdomadaires des Séances de l'Académie des Sciences* 55 (1862): 600-601.  
<https://hdl.handle.net/2027/uc1.31822009249673?urlappend=%3Bseq=606>.

Béguyer de Chancourtois, A. E. *Vis Tellurique: Classement naturel des corps simples ou radicaux, obtenu au moyen d'un système de classification helicoidal et numérique*. Paris: Mallet-Bachelier, 1863.

Benfey, O. Theodor. "Precursors and Cocursors of the Mendeleev Table: The Pythagorean Spirit in Element Classification." *Bulletin for the History of Chemistry* 13-14 (1992-1993): 60-66.  
[http://www.scs.illinois.edu/~mainzv/HIST/bulletin\\_open\\_access/bull-index.php](http://www.scs.illinois.edu/~mainzv/HIST/bulletin_open_access/bull-index.php).

Benfey, Otto Theodor. "Meyer, Julius Lothar." In *Complete Dictionary of Scientific Biography*, 9:347-353. Detroit: Charles Scribner's Sons, 2008.

Bensaude-Vincent, Bernadette. "From Teaching to Writing: Lecture Notes and Textbooks at the French *École polytechnique*." In *Communicating Chemistry: Textbooks and Their Audiences, 1789-1939*, edited by Anders Lundgren and Bernadette Bensaude-Vincent, 273-294. Canton, MA: Science History Publications/USA, 2000.

Bensaude-Vincent, Bernadette. "Graphic Representations of the Periodic System of Chemical Elements." In *Tools and Modes of Representation in the Laboratory Sciences*, edited by U. Klein, 133-161. Dordrecht: Kluwer Academic Publishers, 2001.

Bensaude-Vincent, Bernadette. "Mendeleev's Periodic System of Chemical Elements." *British Journal for the History of Science* 19 (1986): 3-17.  
<http://www.jstor.org/stable/4026481>.

Bensaude-Vincent, Bernadette. "Mendeleev: The Story of a Discovery." In *A History of Scientific Thought: Elements of a History of Science*, edited by Michel Serres, 556-582. Oxford: Blackwell Reference, 1995.

Bensaude-Vincent, Bernadette, and Isabelle Stengers. *A History of Chemistry*. Translated by Deborah van Dam. Cambridge, MA: Harvard University Press, 1996.

Bergman, Torbern. *A Dissertation on Elective Attractions*. 2<sup>nd</sup> ed. With a new introduction by A. M. Duncan. London: Frank Cass & Co. Ltd., 1970. Facsimile London: J. Murray, 1785.

Bertomeu-Sánchez, José Ramón, Antonio García-Belmar, and Bernadette Bensaude-Vincent. "Looking for an Order of Things: Textbooks and Chemical Classifications in Nineteenth Century France." *Ambix* 49 (2002): 227-250.

Berzelius, Jac. "On the Hypothesis of Mr. Prout, With Regard to Atomic Weights." *American Journal of Science*, 1st ser., 48 (1845): 369-372.  
<https://hdl.handle.net/2027/inu.32000007831862?urlappend=%3Bseq=393>.

Bhusan, Nalini, and Stuart Rosenfeld, ed. *Of Minds and Molecules: New Philosophical Perspectives on Chemistry*. New York: Oxford University Press, 2000.

Biagioli, Mario, and Jessica Riskin, ed. *Nature Engaged: Science in Practice from the Renaissance to the Present*. New York: Palgrave Macmillan, 2012.

Blake, James. "On the Atomic Weight of Beryllium as Determined By Its Physiological Action." *Chemical News* 45 (1882): 111.  
<https://hdl.handle.net/2027/wu.89100444736?urlappend=%3Bseq=119>.

Blanc, G.-A., L. Bloch, J. Danne, T. Godlewski, O. Hahn, M. Levin, S. Meyer, M. Moulin, H.-W. Schmidt, E. Schweidler, et al. "Tables des constantes radioactives." *Le Radium* 6 (1909): 1-4. doi:10.1051/radium:01909006010100.

Blitz, Heinrich. "Zur Kenntniss des Perioden-Systems der Elemente." *Berichte der Deutschen Chemischen Gesellschaft* 35 (1902): 562-568.  
<https://hdl.handle.net/2027/iau.31858002459349?urlappend=%3Bseq=566>.

Bodenstein, M., O. Hahn, O. Hönigschmid, R. J. Meyer, and W. Ostwald.  
"Atomgewichtstabellen für das Jahr 1921." *Berichte der Deutschen Chemischen Gesellschaft* 54A (1921): 181-188.  
<https://hdl.handle.net/2027/mdp.39015026351513?urlappend=%3Bseq=197>.

Bohr, Niels. *Niels Bohr: Collected Works*. Vol. 2. Edited by L. Rosenfeld. Amsterdam: North-Holland Publishing Company, 1981.

Bohr, N. "On the Constitution of Atoms and Molecules." *Philosophical Magazine*, 6<sup>th</sup> ser., 26 (1913): 1-25, 857-875.  
<https://archive.org/details/londonedinburg6261913lond>.

Bohr, N. "On the Constitution of Atoms and Molecules. Part II. – Systems Containing Only a Single Nucleus." *Philosophical Magazine*, 6<sup>th</sup> ser., 26 (1913): 476-500.  
<https://archive.org/details/londonedinburg6261913lond>.

Bohr, Niels. *The Theory of Spectra and Atomic Constitution*. Cambridge: Cambridge University Press, 1922.

Boltwood, Bertram B. "The International Congress of Radiology and Electricity, Brussels, September 13-15, 1910." *Science*, n.s., 32 (1910): 788-791.  
<http://www.jstor.org/stable/1636356>.

Boudia, Soraya. "The Curie Laboratory: Radioactivity and Metrology." *History and Technology* 13 (1997): 249-265.

Bowker, Geoffrey C. *Memory Practices in the Sciences*. Cambridge, MA: MIT Press, 2005.

Bowker, Geoffrey C., and Susan Leigh Star. *Sorting Things Out: Classification and Its Consequences*. Cambridge, MA: MIT Press, 1999.

Bradbury, Robert Hart. *Elementary Chemistry*. New York: D. Appleton and Company, 1903. <https://books.google.com/books?vid=HARVARD:32044097019558>.

Brauner, Bohuslav. "The New International Commission on Chemical Elements." *Chemical News* 123 (1921): 230-232.  
<https://hdl.handle.net/2027/mdp.39015073139811?urlappend=%3Bseq=274>.

Brauner, Bohuslav. "Ueber das Atomgewicht des Berylliums." *Berichte der deutschen chemischen Gesellschaft* 14 (1881): 53-58.

<https://hdl.handle.net/2027/mdp.39015026349442?urlappend=%3Bseq=57>.

Bredt, J., H. Erdmann, Ferd Fischer, J. Volhard, Cl. Winkler, and J. Wislicenus.

"International Commission on Atomic Weights." *Chemical News* 82 (1900): 66.

<https://hdl.handle.net/2027/njp.32101075380020?urlappend=%3Bseq=74>.

Brinton, Willard Cope. *Graphic Presentation*. New York: Brinton Associates, 1939.

<https://archive.org/details/graphicpresentat00brinrich>.

"British Association." *Times* (London). August 4, 1906: 10.

Brito, Angmary, Maria A. Rodriguez, and Mansoor Niaz. "A Reconstruction of Development of the Periodic Table Based on History and Philosophy of Science and Its Implications for General Chemistry Textbooks." *Journal of Research in Science Teaching* 42 (2005): 84-111. doi:10.1002/tea.20044.

Brock, W. H. *From Protyle to Proton: William Prout and the Nature of Matter, 1785-1985*. Bristol: Adam Hilger Ltd, 1985.

Brock, William H. *The Norton History of Chemistry*. New York: W. W. Norton & Company, 1993.

Brock, W. H. "Odling, William." In *Complete Dictionary of Scientific Biography*, 10:177-179. Detroit: Charles Scribner's Sons, 2008.

Brock, William H. *William Crookes (1832-1919) and the Commercialization of Science*. Aldershot: Ashgate, 2008.

Brooke, John Hedley. "Introduction: The Study of Chemical Textbooks." In *Communicating Chemistry: Textbooks and Their Audiences, 1789-1939*, edited by Anders Lundgren and Bernadette Bensaude-Vincent, 1-18. Canton, MA: Science History Publications/USA, 2000.

Brooks, Nathan M. "Developing the Periodic Law: Mendeleev's Work During 1869-1871." *Foundations of Chemistry* 4 (2002): 127-147. doi:10.1023/A:1016022129746.

Brooks, Nathan M. "Dmitrii Mendeleev's *Principles of Chemistry* and the Periodic Law of the Elements." In *Communicating Chemistry: Textbooks and Their Audiences, 1789-1939*, edited by Anders Lundgren and Bernadette Bensaude-Vincent, 295-309. Canton, MA: Science History Publications, 2000.

Brooks, Nathan M. "Mendeleev, Dmitrii Ivanovich." In *Complete Dictionary of Scientific Biography*, 23:105-110. Detroit: Charles Scribner's Sons, 2008.

Brown, Theodore L., H. Eugene LeMay, Jr., and Bruce E. Bursten. *Chemistry: The Central Science*. 9<sup>th</sup> ed. Upper Saddle River: Pearson Education, Inc., 2003.

Browne, Owens Hand. "The Problem of the Periodic System." *The Science Teacher* 19 (1952): 271-273. <http://www.jstor.org/stable/24154395>.

Brunsson, Nils, and Bengt Jacobsson. *A World of Standards*. Oxford: Oxford University Press, 2000.

Brush, Stephen G. "The Reception of Mendeleev's Periodic Law in America and Britain." *Isis* 87 (1996): 595-628. <http://www.jstor.org/stable/235195>.

Bucchi, Massimiano. "Images of Science in the Classroom: Wallcharts and Science Education 1850-1920." *British Journal for the History of Science* 31 (1998): 161-184. <http://www.jstor.org/stable/4027761>.

Buchwald, Jed Z., and Andrew Warwick, ed. *Histories of the Electron: The Birth of Microphysics*. Cambridge, MA: MIT Press, 2001.

Busch, Lawrence. *Standards: Recipes for Reality*. Cambridge, MA: MIT Press, 2011.

Calcagni, G. *Trattato di Chimica Generale e Inorganica*. Torino: S. Lattes & C., 1920. [https://hdl.handle.net/2027/uc1.\\$b620100](https://hdl.handle.net/2027/uc1.$b620100).

Cameron, A. T. "The Position of the Radio-active Elements in the Periodic Table." *Nature* 82 (1909): 67-68. doi:10.1038/082067c0.

Campbell, Norman R. "The Nomenclature of Radio-activity." *Nature* 76 (1907): 638. doi:10.1038/076638b0.

Campbell, Norman R. "The Nomenclature of Radioactivity." *Nature* 84 (1910): 203-204. doi:10.1038/084203b0.

Campos, Luis A. *Radium and the Secret of Life*. Chicago: University of Chicago Press, 2015.

Cannizzaro, Stanislao. "Abriss eines Lehrganges der Theoretischen Chemie vorgetragen an der K. Universität Genua." *Ostwalds Klassiker der exakten Wissenschaften* Band 30. Leipzig: Wilhelm Engelmann, 1891. <https://hdl.handle.net/2027/nyp.33433069064255>.

Cannizzaro, Stanislao. "Lettera del Prof. Stanislao Cannizzaro al Prof. S. De Luca; Sunto di un corso di filosofia chimica, fatto nella r. Università di Genova." *Il Nuovo cimento*, 1<sup>st</sup> ser., t.7 (1858): 321-366. <https://hdl.handle.net/2027/hvd.hx3mc9?urlappend=%3Bseq=343>.



Cannizzaro, Stanislao. *Sketch of a Course of Chemical Philosophy*. Alembic Club Reprints, No. 18. Edinburgh: The Alembic Club, 1911.  
<https://hdl.handle.net/2027/uc1.b4255816>.

Carnelley, Thomas. "Influence of Atomic Weight." *Philosophical Magazine*, 5<sup>th</sup> ser., 8 (1879): 305-324, 368-381, 461-476.  
[https://hdl.handle.net/2027/uc1.\\$b785880?urlappend=%3Bseq=319](https://hdl.handle.net/2027/uc1.$b785880?urlappend=%3Bseq=319).

Carnelley, Thos. "A Treatise on the Principles of Chemistry." *Philosophical Magazine*, 5<sup>th</sup> ser., 19 (1885): 222-225.  
[https://hdl.handle.net/2027/uc1.\\$b785891?urlappend=%3Bseq=236](https://hdl.handle.net/2027/uc1.$b785891?urlappend=%3Bseq=236).

Cassebaum, Heinz and George B. Kauffman. "The Periodic System of the Chemical Elements: The Search for Its Discoverers." *Isis* 62 (1971): 314-327.  
<https://www.jstor.org/stable/229945>.

Caven, R. M., and G. D. Lander. *Systematic Inorganic Chemistry, From the Standpoint of the Periodic Law: A Textbook for Advanced Students*. New ed. London: Blackie and Son Limited, 1911. <https://hdl.handle.net/2027/nyp.33433090729660>.

Central Scientific Company. *Laboratory Apparatus for Chemical, Industrial, Bacteriological, Biological, Board of Health and Soil Testing Laboratories*. Chicago: 1918. [https://hdl.handle.net/2027/uc1.\\$c29861](https://hdl.handle.net/2027/uc1.$c29861).

Central Scientific Company. *Physical and Chemical Apparatus*. Chicago: 1909.  
<http://www.sil.si.edu/DigitalCollections/trade-literature/scientific-instruments/pdf/sil14-51679.pdf>.

Chang, Raymond, and Jason Overby. *General Chemistry: The Essential Concepts*. 6<sup>th</sup> ed. New York: McGraw-Hill, 2011.

"Chemical Formulæ." Review of *Tables of Chemical Formulæ*, by William Odling. *Quarterly Journal of Science* 1 (1864): 380.  
<https://hdl.handle.net/2027/mdp.39015013721371?urlappend=%3Bseq=414>.

"Chemical Society." *Chemical News* 13 (1866): 113-114.  
<https://hdl.handle.net/2027/njp.32101075379071?urlappend=%3Bseq=113>.

Chicherin, B. N. *Sistema khimicheskikh elementov*. Petersburg: P. I., 1888.

Christie, Maureen. "Philosophers Versus Chemists Concerning 'Laws of Nature'." *Studies in History and Philosophy of Science* 25 (1994): 613-629. doi:10.1016/0039-3681(94)90050-7.

Christie, Maureen, and John R. Christie. "Laws' and 'Theories' in Chemistry Do Not Obey the Rules." In *Of Minds and Molecules: New Philosophical Perspectives on Chemistry*, edited by Nalini Bhushan and Stuart Rosenfeld, 34-50. New York: Oxford University Press, 2000.

Ciardi, Marco, and Marco Taddia. "Piccini, Ciamician and the Periodic Law in Italy." In *The Circulation of Science and Technology: Proceedings of the 4<sup>th</sup> International Conference of the ESHS*, edited by A. Roca-Rosell, 531-535. Barcelona: SCHCT-IEC, 2012. [http://4eshs.iec.cat/entrada.asp?epigraf\\_contingut=18](http://4eshs.iec.cat/entrada.asp?epigraf_contingut=18).

Clarke, F. W. "Are the Elements Elementary?" *Popular Science Monthly* 8 (1876): 463-471.  
<https://hdl.handle.net/2027/nyp.33433062734631?urlappend=%3Bseq=509>.

Clarke, F. W. "International Atomic Weights." *Chemical News* 90 (1904): 56.  
<https://hdl.handle.net/2027/mdp.39015073139126?urlappend=%3Bseq=388>.

Clarke, F. W. "Report of the International Committee on Atomic Weights." *Journal of the American Chemical Society* 25 (1903): 1-5. doi:10.1021/ja02003a001.

Clarke, F. W. "Sixth Annual Report of the Committee on Atomic Weights. Results Published in 1898." *Journal of the American Chemical Society* 21 (1899): 200-214. doi:10.1021/ja02052a006.

Clarke, F. W. "Tenth Annual Report of the Committee on Atomic Weights. Determinations Published in 1902." *Journal of the American Chemical Society* 25 (1903): 223-231. doi:10.1021/ja02005a001.

Clarke, F. W., W. Ostwald, T. E. Thorpe, and G. Urbain. "Report of the International Committee on Atomic Weights. 1908." *Journal of the American Chemical Society* 30 (1908): 1-4. doi:10.1021/ja01943a001.

Clarke, F. W., W. Ostwald, T. E. Thorpe, and G. Urbain. "Report of the International Committee on Atomic Weights. 1909." *Journal of the American Chemical Society* 31 (1909): 1-6. doi:10.1021/ja01931a001.

Clarke, F. W., T. E. Thorpe, W. Ostwald, and G. Urbain. "Annual Report of the International Committee on Atomic Weights, 1911." *Journal of the American Chemical Society* 32 (1910): 1113-1116. doi:10.1021/ja01928a001.

Clarke, F. W., T. E. Thorpe, W. Ostwald, and G. Urbain. "Annual Report of the International Committee on Atomic Weights, 1912." *Journal of the American Chemical Society* 33 (1911): 1639-1642. doi:10.1021/ja02224a600.

- Clarke, F. W., T. E. Thorpe, W. Ostwald, and G. Urbain. "Annual Report of the International Committee on Atomic Weights, 1914." *Journal of the American Chemical Society* 35 (1913): 1807-1810. doi:10.1021/ja02201a001.
- Clarke, F. W., T. E. Thorpe, and G. Urbain. "Annual Report of the International Committee on Atomic Weights, 1916." *Journal of the Chemical Society, Transactions* 107 (1915): 1282-1285. doi:10.1039/CT9150701282.
- Clarke, F. W., T. E. Thorpe, and G. Urbain. "Report of the International Committee on Atomic Weights for 1919-20." *Journal of the American Chemical Society* 41 (1919): 1881-1887. doi:10.1021/ja02233a600.
- Clarke, F. W., T. E. Thorpe, and G. Urbain. "Report of the International Committee on Atomic Weights for 1921-1922." *Journal of the American Chemical Society* 43 (1921): 1751-1753. doi:10.1021/ja01441a001.
- Clève, P. "On Scandium." *Chemical News* 40 (1879): 159-160.  
<https://hdl.handle.net/2027/wu.89100444694?urlappend=%3Bseq=169>.
- Clève, P. "Sur le scandium." *Comptes Rendus Hebdomadaires des Séances de l'Académie des Sciences* 89 (1879): 419-422.  
<https://hdl.handle.net/2027/nyp.33433009682646?urlappend=%3Bseq=425>.
- Cohen, Benjamin R. "The Element of the Table: Visual Discourse and the Preperiodic Representation of Chemical Classification." *Configurations* 12 (2004): 41-75.  
doi:10.1353/con.2005.0001.
- Cohen, Irwin. "Design of the Periodic Table." *Chemical & Engineering News* 63, no. 8 (1985): 4.
- Complete Dictionary of Scientific Biography*. Detroit: Charles Scribner's Sons, 2008.
- "The Congress of Chemists at Karlsruhe." *Chemical News* 2 (1860): 226-227.  
<https://hdl.handle.net/2027/wu.89054785472?urlappend=%3Bseq=234>.
- Cooke, Josiah P. "The Numerical Relation Between the Atomic Weights, With Some Thoughts on the Classification of the Chemical Elements." *Memoirs of the American Academy of Arts and Sciences*, new ser., 5 (1855): 235-256, 412.  
<http://www.jstor.org/stable/25058181>.
- Cooke, Josiah P. *Religion and Chemistry; or, Proofs of God's Plan in the Atmosphere and Its Elements*. New York: Charles Scribner, 1864.  
<https://hdl.handle.net/2027/hvd.32044004992400>.
- Cox, H. E. "General Chemistry." Review of *General Chemistry*, by H. G. Deming. *Analyst* 49 (1924): 301-302.

Creager, Angela N. H. *Life Atomic: A History of Radioisotopes in Science and Medicine*. Chicago: University of Chicago Press, 2013.

Crookes, William. "Genesis of the Elements." *Notices of the Proceedings at the Meetings of the Members of the Royal Institution of Great Britain* 12 (1889): 37-60. [https://hdl.handle.net/2027/uc1.\\$b522692?urlappend=%3Bseq=51](https://hdl.handle.net/2027/uc1.$b522692?urlappend=%3Bseq=51).

[Crookes, William]. "Notes on the Group of Rare Earths, Considered a Propos of Mr. Crookes's Theory of the Genesis of the Elements." *Chemical News* 56 (1887): 39-40. <https://hdl.handle.net/2027/njp.32101075379337?urlappend=%3Bseq=51>.

Crookes, William. "On Radio-activity and Radium." *Chemical News* 94 (1906): 125. <https://hdl.handle.net/2027/wu.89099510216?urlappend=%3Bseq=407>.

Csiszar, Alex. "Seriality and the Search for Order: Scientific Print and Its Problems During the Late Nineteenth Century." *History of Science* 48 (2010): 399-434. doi:10.1177/007327531004800306.

Cunningham, Andrew and Perry Williams. "De-Centring the 'Big Picture': 'The Origins of Modern Science' and the Modern Origins of Science." *British Journal for the History of Science* 26 (1993): 407-432. <http://www.jstor.org/stable/4027464>.

Curie. "Sur le poids atomique du radium." *Comptes Rendus Hebdomadaires des Séances de l'Académie des Sciences* 135 (1902): 161-163. <https://hdl.handle.net/2027/uc1.31822009517798?urlappend=%3Bseq=167>.

Curie. "Sur le poids atomique du radium." *Comptes Rendus Hebdomadaires des Séances de l'Académie des Sciences* 145 (1907): 422-425. <https://hdl.handle.net/2027/uc1.31822009517871?urlappend=%3Bseq=422>.

Curie. "Sur le poids atomique du Radium." *Le Radium* 4 (1907): 349-352. <https://books.google.com/books?vid=HARVARD:HX3LGV>.

Curie, Madame Sklodowska. "Atomic Weight of the Metal in Radiferous Barium Chloride." *Chemical News* 80 (1899): 281-282. <https://hdl.handle.net/2027/mdp.39015073139134?urlappend=%3Bseq=611>.

Curie, Mdme. "The Atomic Weight of Radium." *Chemical News* 96 (1907): 127. <https://hdl.handle.net/2027/mdp.39015073138953?urlappend=%3Bseq=467>.

Curie, Mdme. "On the Atomic Weight of Radium." *Chemical News* 86 (1902): 61. <https://hdl.handle.net/2027/mdp.39015073139100?urlappend=%3Bseq=395>.

Curie, M<sup>me</sup>. P. "Les Mesures en Radioactivité et l'Étalon du Radium." *Journal de Physique Théorique et Appliquée* 2 (1912): 795-826.  
<https://hdl.handle.net/2027/uiug.30112105671686?urlappend=%3Bseq=805>.

Curie, P., M<sup>me</sup>. P. Curie, G. Bémont. "Radium: A New Body, Strongly Radioactive, Contained in Pitchblende." *Chemical News* 79 (1899): 1-2.  
<https://hdl.handle.net/2027/mdp.39015073139134?urlappend=%3Bseq=7>.

Curie, P., M<sup>me</sup>. P. Curie, and G. Bémont. "Sur une nouvelle substance fortement radioactive, contenue dans la pitchblende." *Comptes Rendus Hebdomadaires des Séances de l'Académie des Sciences* 127 (1898): 1215-1217.  
<https://hdl.handle.net/2027/uc1.31822008929580?urlappend=%3Bseq=1229>.

Curie, P., and Curie, S. "On Polonium: A New Radio-active Substance Contained in Pitchblende." *Chemical News* 78 (1898): 49.  
<https://hdl.handle.net/2027/nyp.33433062748060?urlappend=%3Bseq=57>.

Curie, P., and Curie, S. "Sur une substance nouvelle radio-active, contenue dans la pitchblende." *Comptes Rendus Hebdomadaires des Séances de l'Académie des Sciences* 127 (1898): 175-178.  
<https://hdl.handle.net/2027/uc1.31822008929580?urlappend=%3Bseq=181>.

Curie, Sklodowska. "Rayons émis par les composés de l'uranium et du thorium." *Comptes Rendus Hebdomadaires des Séances de l'Académie des Sciences* 126 (1898): 1101-1103.  
<https://hdl.handle.net/2027/uc1.31822008913949?urlappend=%3Bseq=1109>.

Curie, Sklodowska. "Sur le poids atomique du métal dans le chlorure de baryum radifère." *Comptes Rendus Hebdomadaires des Séances de l'Académie des Sciences* 129 (1899): 760-762.  
<https://hdl.handle.net/2027/uc1.31822009517749?urlappend=%3Bseq=768>.

Dalton, John. *A New System of Chemical Philosophy*. Part 1. Manchester: R. Bickerstaff, 1808. <https://hdl.handle.net/2027/mdp.39015078143743>.

Dalton, John. "On the Absorption of Gases By Water and Other Liquids." *Memoirs of the Literary and Philosophical Society of Manchester*, 2<sup>nd</sup> ser., 1 (1805): 271-287.  
<https://archive.org/details/memoirsofliterar01lite>.

Daston, Lorraine. "Third Nature." In *Science in the Archives: Pasts, Presents, Futures*, edited by Lorraine Daston, 1-14. Chicago: University of Chicago Press, 2017.

Daston, Lorraine, ed. *Science in the Archives: Pasts, Presents, Futures*. Chicago: The University of Chicago Press, 2017.

Davis, E. A., and I. J. Falconer. *J. J. Thomson and the Discovery of the Electron*. London: Taylor & Francis Ltd., 1997.

Davy, Humphry. *The Collected Works of Sir Humphry Davy*. Edited by John Davy, vol. 4. London: Smith, Elder and Co., 1840.  
<https://hdl.handle.net/2027/hvd.32044021235262>.

Dear, Peter. "Historiography of Not-So-Recent Science." *History of Science* 50 (2012): 197-211. doi:10.1177/007327531205000203.

De Bièvre, P., and H. S. Peiser. "'Atomic Weight' – The Name, Its History, Definition, and Units." *Pure & Applied Chemistry* 64 (1992): 1535-1543.  
doi:10.1351/pac199264101535.

de Boisbaudran, Lecoq. "Caractères chimiques et spectroscopiques d'un nouveau métal, le Gallium, découvert dans une blende de la mine de Pierrefitte, vallée d'Argelès (Pyrénées)." *Comptes Rendus Hebdomadaires des Séances de l'Académie des Sciences* 81 (1875): 493-495.  
<https://hdl.handle.net/2027/uc1.31822009517228?urlappend=%3Bseq=501>.

de Boisbaudran. "Classification des éléments chimiques." *Comptes Rendus Hebdomadaires des Séances de l'Académie des Sciences* 120 (1895): 1097-1103.  
<https://hdl.handle.net/2027/uc1.31822009517673?urlappend=%3Bseq=1107>.

de Boisbaudran, Lecoq. "On the new metal – gallium." *Chemical News* 35 (1877): 148-151, 157-160, 167-170.  
<https://hdl.handle.net/2027/nyp.33433062749308?urlappend=%3Bseq=164>.

de Boisbaudran, Lecoq. "Recherches sur le samarium, radical d'une terre nouvelle extraite de la samarskite." *Comptes Rendus Hebdomadaires des Séances de l'Académie des Sciences* 89 (1879): 212-214.  
<https://hdl.handle.net/2027/uc1.31822009517434?urlappend=%3Bseq=218>.

de Boisbaudran, Lecoq. "Sur un nouveau métal, le gallium." *Annales de Chimie et de Physique*, 5<sup>th</sup> ser., 10 (1877): 100-141.  
<https://hdl.handle.net/2027/hvd.hx3e1k?urlappend=%3Bseq=104>.

de Boisbaudran, Lecoq, and A. de Lapparent. "A Reclamation of Priority on Behalf of M. de Chancourtois Referring to the Numerical Relations of the Atomic Weights." *Chemical News* 63 (1891): 51-52.  
<https://hdl.handle.net/2027/nyp.33433062748128?urlappend=%3Bseq=59>.

de Boisbaudran, Lecoq, et A. de Lapparent. "Sur une réclamation de priorité en faveur de M. de Chancourtois, relativement aux relations numériques des poids atomiques." *Comptes Rendus Hebdomadaires des Séances de l'Académie des Sciences* 112 (1891): 77-81.

<https://hdl.handle.net/2027/uc1.31822009517608?urlappend=%3Bseq=85>.

DeKosky, Robert K. "Spectroscopy and the Elements in the Late Nineteenth Century: The Work of Sir William Crookes." *The British Journal for the History of Science* 6 (1973): 400-423. <http://www.jstor.org/stable/4025503>.

Demarçay, Eug. "The Spectrum of a Radio-active Substance." *Chemical News* 79 (1899): 13.

<https://hdl.handle.net/2027/mdp.39015073139134?urlappend=%3Bseq=19>.

Demarçay, Eug. "Sur le spectre d'une substance radio-active." *Comptes Rendus Hebdomadaires des Séances de l'Académie des Sciences* 127 (1898): 1218.

<https://hdl.handle.net/2027/uc1.31822008929580?urlappend=%3Bseq=1232>.

deMilt, Clara. "Carl Weltzein and the Congress at Karlsruhe." *Chymia* 1 (1948): 153-169. <http://www.jstor.org/stable/27757121>.

deMilt, Clara. "The Congress at Karlsruhe." *Journal of Chemical Education* 28 (1951): 421-425. doi:10.1021/ed028p421.

Deming, Horace G. *Fundamental Chemistry: An Elementary Textbook for College Classes*. 2<sup>nd</sup> ed. New York: John Wiley & Sons, Inc., 1947.

Deming, Horace G. *General Chemistry: An Elementary Suvery Emphasizing Industrial Applications of Fundamental Principles* New York: John Wiley & Sons, Inc., 1923.

"Discussion on the Structure of Atoms and Molecules." In *Report of the Eighty-Fourth Meeting of the British Association for the Advancement of Science, Australia, 1914*, 293-301. London: John Murray, 1915.

<https://biodiversitylibrary.org/page/30399786>.

D[ixon], H. B. "William Odling, 1829-1921." *Philosophical Transactions of the Royal Society of London* 100A (1922): i-vii. <http://www.jstor.org/stable/93936>.

Dmitriev, Igor S. "Scientific Discovery *in statu nascendi*: The Case of Dmitrii Mendeleev's Periodic Law." *Historical Studies in the Physical and Biological Sciences* 34 (2004): 233-275. <http://www.jstor.org/stable/10.1525/hsp.2004.34.2.233>.

Dmitriev, Igor S., Pavel D. Sarkisov, and Ilya I. Moiseev. "Dmitry Ivanovich Mendeleev: Scientist, Citizen, and Personality." *Rendiconti Lincei* 21 (2010): 111-130. doi: 10.1007/s12210-010-0074-4.

- Döbereiner, J. W. "Versuch zu einer Gruppierung der elementaren Stoffe nach ihrer Analogie." *Annalen der Physik* 91 (1829): 301-307.  
<https://hdl.handle.net/2027/uiug.30112053427693?urlappend=%3Bseq=317>.
- Dougal, Margaret D. "On the Teaching of Inorganic Chemistry." *Chemical News* 68 (1893): 223-225, 237-238, 247-248, 260-261.  
<https://hdl.handle.net/2027/inu.30000088771062?urlappend=%3Bseq=555>.
- Drake, Robert F. "More on the Periodic Table." *Chemical & Engineering News* 63, no. 11 (1985): 2.
- Dull, Charles. *High School Chemistry*. New York: Henry Holt and Company, 1925.
- Dull, Charles. *Modern Chemistry*. New York: Henry Holt and Company, 1931.
- Dumas, J. "Mémoire sur les Équivalents des Corps Simples." *Comptes Rendus Hebdomadaires des Séances de l'Académie des Sciences* 45 (1857): 709-731.  
<https://gallica.bnf.fr/ark:/12148/bpt6k30026/f711.item>.
- Dumas, J. "Mémoire sur les Équivalents des Corps Simples." *Annales de Chimie et de Physique*, 3<sup>rd</sup> ser, 55 (1859): 129-210.  
<https://hdl.handle.net/2027/uva.x002489063?urlappend=%3Bseq=133>.
- Dumas. "On the Transmutation of Bodies." *Chemical Record and Drug Price Current* 1 (1851): 5-6. <https://hdl.handle.net/2027/hvd.hxf6e?urlappend=%3Bseq=17>.
- Dumas, J., and Stas. "Sur le véritable poids atomique du carbone." *Annales de Chimie et de Physique*, 3<sup>rd</sup> ser, 1 (1841): 5-59.  
<https://hdl.handle.net/2027/msu.31293024223673?urlappend=%3Bseq=9>.
- Dunbar, Ralph E. "Changing Conception of Teaching Helps in College General Chemistry Textbooks." *Journal of Chemical Education* 15 (1938): 336-339.  
doi:10.1021/ed015p336.
- Duncan, A. M. "The Functions of Affinity Tables and Lavoisier's List of Elements." *Ambix* 17 (1970): 28-42.
- Eddy, Matthew Daniel. "How to See a Diagram: A Visual Anthropology of Chemical Affinity." *Osiris* 29 (2014): 178-196. doi: 10.1086/678093.
- Eddy, Matthew Daniel. "The Shape of Knowledge: Children and the Visual Culture of Literacy and Numeracy." *Science in Context* 26 (2013): 215-245.  
doi:10.1017/S0269889713000045.



Emerson, B. K. "Concerning a New Arrangement of the Elements on a Helix, and the Relationships Which May Be Usefully Expressed Thereon." *Science*, n.s., 34 (1911): 640-652. <http://www.jstor.org/stable/1638654>.

Emerson, B. K. "The Helix Chemica." *Chemical Reviews* 5 (1928): 215-229. doi:10.1021/cr60018a004.

Emerson, B. K. "Helix Chemica: A Study of the Periodic Relations of the Elements and Their Graphic Representation." *American Chemical Journal* 45 (1911): 160-210. <https://hdl.handle.net/2027/uva.x004036289?urlappend=%3Bseq=232>.

Emsley, John. "The Development of the Periodic Table of the Chemical Elements." *Interdisciplinary Science Reviews* 12 (1987): 23-32.

Enghag, Per. *Encyclopedia of the Elements: Technical Data, History, Processing, Applications*. Weinheim: Wiley-VCH, 2004.

Errera, L. "Magnetisme et poids atomique." *Bulletin de la Classe des Sciences. Académie Royale de Belgique* 1900: 152-161. <https://hdl.handle.net/2027/njp.32101064104894?urlappend=%3Bseq=162>.

Estreicher, T. "Canadium." *Chemical News* 105 (1912): 119. <https://hdl.handle.net/2027/mdp.39015073139274?urlappend=%3Bseq=125>.

Eve, A. S. "Modern Views on the Constitution of the Atom." *Science*, n.s., 40 (1914): 115-121. <http://www.jstor.org/stable/1638909>.

Eve, A. S. "Radium." *Times* (London). August 28, 1906: 6.

Everett-Lane, Debra Adrienne. "International Scientific Congresses, 1878-1913: Community and Conflict in the Pursuit of Knowledge." PhD diss., Columbia University, 2004. Order No. 3115380. <http://silk.library.umass.edu/login?url=http://search.proquest.com.silk.library.umass.edu/docview/305208053?accountid=14572>.

"Extracts from the Proceedings of the Twenty-first Meeting of the British Association, Held at Ipswich, July 2." *American Journal of Science and Arts*, 2<sup>nd</sup> ser., 12 (1851): 261-278. <https://hdl.handle.net/2027/umn.31951000569248x?urlappend=%3Bseq=279>.

Fajans, K. *Radioactivity and the Latest Developments in the Study of the Chemical Elements*. From the 4<sup>th</sup> German ed. Translated by T. S. Wheeler and W. G. King. London: Methuen & Co. Ltd., 1923.

Faraday. *The Subject Matter of a Course of Six Lectures on the Non-Metallic Elements*. London: Longman, Brown, Green, and Longmans, 1853.  
<https://hdl.handle.net/2027/mdp.39015065709852>.

Fennell, Roger. *History of IUPAC, 1919-1987*. London: Blackwell Science, 1994.

Fernelius, W. Conard. "Some Reflections on the Periodic Table and Its Use." *Journal of Chemical Education* 63 (1986): 263-266. doi:10.1021/ed063p263.

Fernelius, W. C., and W. H. Powell. "Confusion in the Periodic Table of the Elements." *Journal of Chemical Education* 59 (1982): 504-508. doi:10.1021/ed059p504.

Fischer, Emil. "Recent Advances and Problems in Chemistry." *Nature* 85 (1911): 558-563. doi:10.1038/085558b0.

Fisher, Susie. "William Odling: 'Interpreter and Liaison-Officer,' Advocate of a New System of Chemistry." *Ambix* 43 (1996): 146-163.

Flavitzky, Flavian. *A Function Expressing the Periodicity of the Chemical Elements*. Kazan, 1887.

Fleck, Alexander. "The Chemistry of the Radio-elements." *Chemical News* 108 (1913): 175-176.  
<https://hdl.handle.net/2027/mdp.39015073139282?urlappend=%3Bseq=513>.

Fleck, H. "G. Hinrichs: Atomechanik oder die Chemie eine Mechanick der Panatome." Review of *Programme der atomechanik oder die chemie eine mechanik der panatome*, by Gustavus Hinrichs. *Neues Jahrbuch für Mineralogie, Geologie und Paläontologie*, 1868: 333-335.  
<https://hdl.handle.net/2027/mdp.39015065878327?urlappend=%3Bseq=357>.

Fisher, Joseph. "The History of Landholding in Ireland." *Transactions of the Royal Historical Society* 5 (1877): 228-326. <http://www.jstor.org/stable/3677953>.

Foster, G. C. "On Chemical Nomenclature." *Philosophical Magazine*, 4<sup>th</sup> ser., 30 (1865): 57-59.  
<https://hdl.handle.net/2027/njp.32101076464898?urlappend=%3Bseq=71>.

Foster, G. C. "On Chemical Nomenclature, and Chiefly on the Use of the Word Acid." *Philosophical Magazine*, 4<sup>th</sup> ser., 29 (1865): 262-269.  
<https://hdl.handle.net/2027/njp.32101076464906?urlappend=%3Bseq=280>.

Foster, Laurence S. "Handbook of Chemistry." Review of *Handbook of Chemistry*, by Norbert A. Lange. *Journal of Chemical Education* 21 (1944): 520.  
doi:10.1021/ed021p520.2.

Foster, Laurence S. "Why Not Modernize the Textbooks Also? I. The Periodic Table." *Journal of Chemical Education* 16 (1939): 409-412. doi:10.1021/ed016p409.

Foster, William. *Introduction to General Chemistry*. Princeton: Princeton University Press, 1924.

Freeman, P. J. "The Life and Times of William Odling (1829-1921), Waynflete Professor of Chemistry, 1872-1912." B.Sc. thesis, Oxford, 1963.

Freund, Ida. *The Study of Chemical Composition: An Account of its Method and Historical Development*. New York: Dover Publications, Inc., 1968.

Funkhouser, H. Gray. "Historical Development of the Graphical Representation of Statistical Data." *Osiris* 3 (1937): 269-404. <http://www.jstor.org/stable/301591>.

García-Belmar, Antonio, José Ramón Bertomeu-Sánchez, and Bernadette Bendaude-Vincent. "The Power of Didactic Writings: French Chemistry Textbooks of the Nineteenth Century." In *Pedagogy and the Practice of Science: Historical and Contemporary Perspectives*, edited by David Kaiser, 219-251. Cambridge: The MIT Press, 2005.

Garrett, A. E. *The Periodic Law*. New York: D. Appleton and Company, 1909. <https://archive.org/details/periodiclawthein013791mbp>.

Geoffroy, Etienne-François. "Table des différens rapports observés en Chymie entre différentes substances." *Mémoires de l'Académie Royale des Sciences* 1718: 202-212.

Geoffroy, Etienne-François. "Table of the Different Relations Observed in Chemistry Between Different Substances." *Science in Context* 9 (1996): 313-320. Translated by Andrew Mendelsohn in cooperation with Ursula Klein.

Gerhardt, C. *Preis-Verzeichniss über Chemische Apparate und Geräthschaften, Chemische Präparate und Reagentien*. Bonn: 1898. <https://archive.org/details/preisverzubechem00gerhrich>.

Gibbs, Oliver Wolcott. *An Inaugural Dissertation on a Natural System of Chemical Classification*. M.D. diss., College of Physicians and Surgeons, New York. Princeton: John T. Robinson, 1845. <https://hdl.handle.net/2027/nnc2.ark:/13960/t3qv4bd56>.

Gillispie, Charles. *The Edge of Objectivity: An Essay in the History of Scientific Ideas*. Princeton: Princeton University Press, 1960.

Giunta, Carmen. "J. A. R. Newlands' Classification of the Elements: Periodicity, But No System." *Bulletin for the History of Chemistry* 24 (1999): 24-31. [http://www.scs.illinois.edu/~mainzv/HIST/bulletin\\_open\\_access/bull-index.php](http://www.scs.illinois.edu/~mainzv/HIST/bulletin_open_access/bull-index.php).

- Gladstone, J. H. "On the Relations Between the Atomic Weights of Analogous Elements." *Philosophical Magazine*, 4<sup>th</sup> ser., 5 (1853): 313-320.  
<https://hdl.handle.net/2027/uc1.31822016397317?urlappend=%3Bseq=337>.
- Glinka, N. L. *General Chemistry*. 3<sup>rd</sup> ed., vol. 1. Translated by G. Leib and edited by V. Rabinovich. Moscow: Mir Publishers, 1981. Revised from the 1980 enlarged and updated Russian edition.
- Gmelin, Leopold. *Hand-Book of Chemistry*. Vol. 2. Translated by Henry Watts. London, 1849. <https://hdl.handle.net/2027/mdp.39015067141054>.
- Golinski, Jan. *Science as Public Culture: Chemistry and Enlightenment in Britain, 1760-1820*. New York: Cambridge University Press, 1992.
- Gooch, Frank Austin, and Claude Frederic Anderson. *Outlines of Inorganic Chemistry*. New York: The Macmillan Company, 1905.  
<https://books.google.com/books?vid=HARVARD:32044091983031>.
- Gordin, Michael D. *Scientific Babel: How Science Was Done Before and After Global English*. Chicago: The University of Chicago Press, 2015.
- Gordin, Michael. "The Textbook Case of a Priority Dispute: D. I. Mendeleev, Lothar Meyer, and the Periodic System." In *Nature Engaged: Science in Practice from the Renaissance to the Present*, edited by Mario Biagioli and Jessica Riskin, 59-82. New York: Palgrave Macmillan, 2012.
- Gordin, Michael D. "Translating Textbooks: Russian, German, and the Language of Chemistry." *Isis* 103 (2012): 88-98. <http://www.jstor.org/stable/10.1086/664980>.
- Gordin, Michael D. *A Well-Ordered Thing: Dmitrii Mendeleev and the Shadow of the Periodic Table*. New York: Basic Books, 2004.
- Green, William A. "Periodization in European and World History." *Journal of World History* 1 (1992): 13-53. <http://www.jstor.org/stable/20078511>.
- Gross, Alan G., Joseph E. Harmon, and Michael Reidy, *Communicating Science: The Scientific Article from the 17<sup>th</sup> Century to the Present*. New York: Oxford University Press, 2002.
- Grosse, Aristid V. "Element 91." *Science*, n.s., 80 (1934): 512-516.  
<http://www.jstor.org/stable/1660876>.
- "Group Notation Revised in Periodic Table." *Chemical & Engineering News* 63, no. 5 (1985): 26-27.

H., J. "Prof. Bohuslav Brauner." *Nature* 135 (1935): 497-498.  
doi:10.1038/135497a0.

*Handbook of Chemistry and Physics: A Ready-Reference Pocket Book of Chemical and Physical Data.* Cleveland: The Chemical Rubber Company, 1913.  
<https://books.google.com/books?id=fPdUAAAAMAAJ>.

Hankins, Thomas L. "Blood, Dirt, and Nomograms: A Particular History of Graphs." *Isis* 90 (1999): 50-80. <http://www.jstor.org/stable/237474>.

Hankins, Thomas L., and Robert J. Silverman. *Instruments and the Imagination.* Princeton: Princeton University Press, 1995.

Harkins, William D., and R. E. Hall. "The Periodic System and the Properties of the Elements." *Journal of the American Chemical Society* 38 (1916): 169-221.  
doi:10.1021/ja02259a001.

Hartog, P. J. "A First Foreshadowing of the Periodic Law." *Nature* 41 (1889): 186-188. doi:10.1038/041186a0.

Haughton, Samuel. "Geometrical Illustrations of Newlands' and Mendelejeff's Periodic Law of the Atomic Weights of the Chemical Elements." *Transactions of the Royal Irish Academy* 29 (1887-1892): 207-246.  
<http://www.jstor.org/stable/30078815>.

Heilbron, J. L. *H. G. J. Moseley: The Life and Letters of an English Physicist, 1887-1915.* Berkeley: University of California Press, 1974.

Heimann, P. M. "Moseley and Celtium: The Search for a Missing Element." *Annals of Science* 23 (1967): 249-260.

Hepler-Smith, Evan. "'Just as the Structural Formula Does': Names, Diagrams, and the Structure of Organic Chemistry at the 1892 Geneva Nomenclature Congress." *Ambix* 62 (2015): 1-28. doi: 10.1179/1745823414Y.0000000006.

Herschel, J. F. W. *A Preliminary Discourse on the Study of Natural Philosophy.* London, 1831. <https://hdl.handle.net/2027/umn.319510009534720>.

Hildebrand, Joel H. *Principles of Chemistry.* Preliminary ed. Berkeley: Lederer, Street & Zeus Co., Publishers, 1917. [https://hdl.handle.net/2027/uc1.\\$b100552](https://hdl.handle.net/2027/uc1.$b100552).

Hildebrand, Joel H. *Principles of Chemistry.* New York: The Macmillan Company, 1918. [https://hdl.handle.net/2027/uc1.\\$b277972](https://hdl.handle.net/2027/uc1.$b277972).

Hinds, J. I. D. *Inorganic Chemistry, with Elements of Physical and Theoretical Chemistry*, 1<sup>st</sup> ed. New York: John Wiley & Sons, 1902.  
<https://books.google.com/books?vid=HARVARD:32044091927608>.

Hinrichs, G.-D. 1873-1910. *Quelques lettres, en facsimilé, de quelques collègues, membres de l'Institut de France, Académie des sciences, sur le calcul des poids atomiques, sur l'unité de la matière et sur le monument Lavoisier*. St. Louis: Woodward & Tiernan Printing Co., 1910.  
<http://hdl.handle.net/2027/wu.89102114857>.

Hinrichs, Gustav. *Programme der atomechanik oder die chemie eine mechanik der panatome*. Iowa City: Vereinigte Staaten, N.A., 1867.  
<https://hdl.handle.net/2027/mdp.39015018048952>.

Hinrichs, Gustavus. "Natural Classification of the Elements." *The Pharmacist* 1 (1869): 10-12.  
<https://hdl.handle.net/2027/chi.095492771?urlappend=%3Bseq=50>.

Hinrichs, Gustavus. "On the Classification and the Atomic Weights of the So-called Chemical Elements, With Reference to Stas' Determinations." *Proceedings of the American Association for the Advancement of Science* 18 (1869): 112-124.  
<https://hdl.handle.net/2027/uc1.b3082769?urlappend=%3Bseq=158>.

Hinrichs, Gustavus. "On the Distribution of the Dark Lines in the Spectra of the Elements." *American Journal of Science and Arts*, 2<sup>nd</sup> ser., 38 (1864): 31-40.  
<https://biodiversitylibrary.org/page/36818143>.

Hinrichs, Gustavus. "On the Spectra and Composition of the Elements." *American Journal of Science and Arts*, 2<sup>nd</sup> ser., 42 (1866): 350-368.  
<https://biodiversitylibrary.org/page/36817782>.

Hinrichs, Gustavus. *A Programme of Atomechanics; Or, Chemistry as a Mechanics of the Panatoms*. Iowa City, 1867. <https://books.google.com/books?id=3jtSAAAACAAJ>.

Hinrichs, Gustavus Detlef. *The Elements of Chemistry and Mineralogy: Demonstrated by the Student's Own Experiments*. Davenport, IA: Griggs, Watson, & Day, 1871.  
<https://archive.org/details/elementsofchemis00hinr>.

Hinrichs, Gustavus Detlef. *Introduction to General Chemistry: A Graded Course of One Hundred Lectures*. St. Louis: Carl Gustav Hinrichs, Publisher, 1897.  
<https://books.google.com/books?id=zhVDAAAIAAJ>.

Hinrichs, Gustavus Detlef. *The True Atomic Weights of the Chemical Elements and the Unity of Matter*. St. Louis: Carl Gustav Hinrichs, 1894.  
<https://books.google.com/books?id=8XAMAQAIAAJ>.

"Hinrich's Atom Mechanics." Review of *Programme der atomechanik oder die chemie eine mechanik der panatome*, by Gustavus Hinrichs. *American Journal of Science and the Arts*, 2<sup>nd</sup> ser., 46 (1868): 258-260.  
<https://biodiversitylibrary.org/page/36897953>.

Hodgkinson, W. R. "Arrangement of Chemical Lectures." *Chemical News* 68 (1893): 184. <https://hdl.handle.net/2027/inu.30000088771062?urlappend=%3Bseq=516>.

Holden, Norman E. "Atomic Weights and the International Committee – A Historical Review." *Chemistry International* 26 (2004). doi:10.1515/ci.2004.26.1.4. An extract appeared in the print edition of *Chemistry International*, 26 (2004): 4-7.

Holleman, A. F. *A Text-book of Inorganic Chemistry*. 6<sup>th</sup> English ed. New York: John Wiley & Sons, Inc., 1921. <https://books.google.com/books?id=vrxhAAAAIAAJ>.

Hopkins, B. Smith. *General Chemistry for Colleges*. Boston: D. C. Heath and Company, 1930.

Howe, Jas. Lewis. "The Eighth Group of the Periodic System and Some of Its Problems." *Science*, n.s., 11 (1900): 1012-1020; 12 (1900): 20-34.  
<http://www.jstor.org/stable/1627320>; <http://www.jstor.org/stable/1627722>.

H[owe], J[ames] L[ewis]. "Second Report of the Committee of the German Chemical Society on Atomic Weights." *Science*, n.s., 12 (1900): 246-247.  
<http://www.jstor.org/stable/1629662>.

Howorth, Muriel. *Pioneer Research on the Atom: The Life Story of Frederick Soddy*. London: New World Publications, 1958.

Hubbard, Henry D. "Magic in Graphs." In *Graphic Presentation*, by Willard Cope Brinton. New York: Brinton Associates, 1939.  
<https://archive.org/details/graphicpresentat00brinrich>.

Hubbard, Henry D. *Primer of the Atoms: A Key to the Periodic Chart of the Atoms*. Chicago: W. M. Welch Manufacturing Company, 1937.

Hughes, Jeff. "Radioactivity and Nuclear Physics." In *The Modern Physical and Mathematical Sciences*, edited by Mary Jo Nye, vol. 5 of *The Cambridge History of Science*, 350-374. Cambridge: Cambridge University Press, 2002.

Hughes, Jeffrey Alan. "The Radioactivists: Community, Controversy and the Rise of Nuclear Physics." PhD diss., Cambridge University, 1993.

Humpidge, T. S. "New Metals." *Nature* 22 (1880): 232-233. doi:10.1038/022232a0.

Humpidge, T. S. "On the Atomic Weight of Beryllium." *Chemical News* 42 (1880): 261-263.

<https://hdl.handle.net/2027/njp.32101075379477?urlappend=%3Bseq=271>.

Humpidge, T. S. "On the Atomic Weight of Glucinum (Beryllium)." *Philosophical Transactions of the Royal Society of London* 174 (1883): 601-613.

<http://www.jstor.org/stable/109419>.

Humpidge, T. S. "On the Atomic Weight of Glucinum (Beryllium). Second Paper." *Proceedings of the Royal Society of London* 39 (1885): 1-19.

<http://www.jstor.org/stable/114166>.

Humpidge, T. S. "On the Atomic Weight of Glucinum (Beryllium). Second Paper. [Abstract]." *Proceedings of the Royal Society of London* 38 (1884): 188-191.

<http://www.jstor.org/stable/114238>.

Hunt, T. Sterry. "A Century's Progress in Chemical Theory." *American Chemist* 5 (1874-75): 56-61.

[https://hdl.handle.net/2027/uc1.\\$b614509?urlappend=%3Bseq=64](https://hdl.handle.net/2027/uc1.$b614509?urlappend=%3Bseq=64).

Ihde, Aaron J. "The Karlsruhe Congress: A Centennial Retrospect." *Journal of Chemical Education* 38 (1961): 83-86. doi:10.1021/ed038p83.

"The Interallied Chemical Conference." *Science*, n.s., 50 (1919): 224-225.

<http://www.jstor.org/stable/1642166>.

"International Association of Chemical Societies." *Journal of Industrial and Engineering Chemistry* 3 (1911): 614. doi:10.1021/ie50032a021.

"International Association of Chemical Societies." *Journal of the American Chemical Society* 36 (1914): 76-84. doi:10.1021/ja02178a009.

"International Conference of Chemistry." *Nature* 107 (1921): 787-788.

doi:10.1038/107787a0.

"Internationale Vereinbarungen in chemischen Grundfragen." *Chemiker Zeitung* 24 (1900): 281-282.

<https://hdl.handle.net/2027/njp.32101050964954?urlappend=%3Bseq=305>.

Izquierdo, Mercè. "Three Rhetorical Constructions of the Chemistry of Water." In *Communicating Chemistry: Textbooks and Their Audiences, 1789-1939*, edited by Anders Lundgren and Bernadette Bensaude-Vincent, 255-272. Canton, MA: Science History Publications/USA, 2000.



James, Frank A. L. "The Practical Problems of a 'New' Experimental Science: Spectro-Chemistry and the Search for Hitherto Unknown Elements in Britain, 1860-1869." *British Journal of the History of Science* 21 (1988): 181-194.  
<http://www.jstor.org/stable/4026978>.

Jensen, William B. "Physical Chemistry Before Ostwald: The Textbooks of Josiah Parsons Cooke." *Bulletin for the History of Chemistry* 36 (2011): 10-21.  
[http://www.scs.illinois.edu/~mainzv/HIST/bulletin\\_open\\_access/bull-index.php](http://www.scs.illinois.edu/~mainzv/HIST/bulletin_open_access/bull-index.php).

Jones, Harry C. "The Atomic Weight of Radium and the Periodic System." *American Chemical Journal* 34 (1905): 467-471.  
<https://hdl.handle.net/2027/umn.319510006175551?urlappend=%3Bseq=487>.

Jones, Harry C. *The Elements of Physical Chemistry*. 3<sup>rd</sup> ed. New York: The Macmillan Company, 1907. <https://hdl.handle.net/2027/mdp.39015078163105>.

Jones, Harry C. "The Introduction of Physical Chemical Conceptions in the Early Stages of the Teaching of Chemistry." *Science*, n.s., 35 (1912): 87-88.  
<http://www.jstor.org/stable/1637415>.

Jones, Harry C. *Introduction to Physical Chemistry*. 2<sup>nd</sup> edition, revised. New York: The Macmillan Company, 1914.  
<https://hdl.handle.net/2027/iau.31858047931062>.

Kaiser, David, ed. *Pedagogy and the Practice of Science: Historical and Contemporary Perspectives*. Cambridge: The MIT Press, 2005.

Kaji, Masanori. "Chemical Classification and the Response to the Periodic Law of Elements in Japan in the Nineteenth and Early Twentieth Centuries." In *Early Responses to the Periodic System*, edited by Masanori Masanori, Helge Kragh, and Gábor Palló, 283-304, New York: Oxford University Press, 2015.

Kaji, Masanori. "Mendeleev's Discovery of the Periodic Law: The Origin and the Reception." *Foundations of Chemistry* 5 (2003): 189-214.  
doi:10.1023/A:1025673206850.

Kaji, Masanori, and Nathan Brooks. "The Early Response to Mendeleev's Periodic System in Russia." In *Early Responses to the Periodic System*, edited by Masanori Masanori, Helge Kragh, and Gábor Palló, 13-46, New York: Oxford University Press, 2015.

Kaji, Masanori, Helge Kragh, and Gábor Palló, ed. *Early Responses to the Periodic System*. New York: Oxford University Press, 2015.

Kedrov, B. M. "Mendeleev, Dmitry Ivanovich." In *Complete Dictionary of Scientific Biography*, 9:286-295. Detroit: Charles Scribner's Sons, 2008.

Keenan, Charles W., Donald C. Kleinfelter, and Jesse H. Wood. *General College Chemistry*. 6<sup>th</sup> ed. San Francisco: Harper & Row, Publishers, 1980.

Kelvin. "Radium." *Times* (London). August 9, 1906: 3.

Kelvin. "The Recent Radium Controversy." *Nature* 74 (1906): 539.  
doi:10.1038/074539a0.

Kendall, Martha B. "Béguyer de Chancourtois, Alexandre-Émile." In *Complete Dictionary of Scientific Biography*, 1:572-573. Detroit: Charles Scribner's Sons, 2008.

Kirby, H. W. "The Discovery of Actinium." *Isis* 62 (1971): 290.  
<http://www.jstor.org/stable/229943>.

Kim, Mi Gyung. *Affinity, That Elusive Dream: A Genealogy of the Chemical Revolution*. Cambridge, MA: MIT Press, 2003.

Klein, U., ed. *Tools and Modes of Representation in the Laboratory Sciences*. Dordrecht: Kluwer Academic Publishers, 2001.

Klein, Ursula, and Wolfgang Lefèvre. *Materials in Eighteenth-Century Science: A Historical Ontology*. Cambridge, MA: MIT Press, 2007.

Knight, David M. *Classical Scientific Papers: Chemistry, Second Series*. London: Mills & Boon Limited, 1970.

Knight, David M. *The Transcendental Part of Chemistry*. Folkstone: Dawson, 1978.

Knorre, Elaine. *A Visit to Transurania*. Translated by M. Brodskaya and edited by H. C. Creighton. Moscow: Mir Publishers, 1974. Revised from the Russian, 1971.

Kauffman, George B. "American Forerunners of the Periodic Law." *Journal of Chemical Education* 46 (1969): 128-135. doi:10.1021/ed046p128.

Kauffman, George B. "The Reception of Mendeleev's Ideas in the United States and Mendeleev's Correspondence with American Scientists." *Archives Internationales d'Histoire des Sciences* 23 (1970): 87-106.

Korsunskii, M. I. *Atomic Nucleus*. 4<sup>th</sup> ed. Moscow: State Publishing House for Technical-Theoretical Literature, 1952.

Kragh, Helge. "The Aether in Late Nineteenth Century Chemistry." *Ambix* 36 (1989): 49-65.

Kragh, Helge. "Conceptual Changes in Chemistry: The Notion of a Chemical Element, ca. 1900-1925." *Studies in History and Philosophy of Modern Physics* 31 (2000): 435-450. doi:10.1016/S1355-2198(00)00025-3.

Kragh, Helge. "The First Subatomic Explanations of the Periodic System." *Foundations of Chemistry* 3 (2001): 129-143. doi:10.1023/A:1011448410646.

Kragh, Helge. "From Geochemistry to Cosmochemistry: The Origin of a Scientific Discipline, 1915-1955." In *Chemical Sciences in the 20<sup>th</sup> Century: Bridging Boundaries*, edited by Carsten Reinhardt, 160-190. Weinheim: Wiley-VCH, 2001.

Kragh, Helge. *Niels Bohr and the Quantum Atom: The Bohr Model of Atomic Structure, 1913-1925*. Oxford: Oxford University Press, 2012.

Kragh, Helge. "The Reception of the Periodic System in Denmark." In *The Circulation of Science and Technology: Proceedings of the 4<sup>th</sup> International Conference of the ESHS*, edited by A. Roca-Rosell, 525-530. Barcelona: SCHCT-IEC, 2012. [http://4eshs.iec.cat/entrada.asp?epigraf\\_contingut=18](http://4eshs.iec.cat/entrada.asp?epigraf_contingut=18).

Kremers, P. "Ueber den Zusammenhang des specifischen Gewichtes chemischer Verbindungen mit ihrer Auflöslichkeit in Wasser, nebst einer daraus abgeleiteten Theorie der Wahlverwandschaften." *Annalen der Physik und Chemie* 85 (1852): 37-57, 246-262. doi:10.1002/andp.18521610105, doi:10.1002/andp.18521610210. (New volume numbering: 161 (1852).)

Kremers, P. "Ueber die Modification der mittleren Eigenschaft." *Annalen der Physik und Chemie* 99 (1856): 58-63. <https://hdl.handle.net/2027/umn.31951d00326536n?urlappend=%3Bseq=74>.

Kremers, P. "Ueber die Modification der mittleren Löslichkeit einiger Salzatome und des mittleren Volums dieser Lösungen." *Annalen der Physik und Chemie* 103 (1858): 57-68, 104 (1858): 133-162. <https://hdl.handle.net/2027/umn.31951d00326542s?urlappend=%3Bseq=73>, <https://hdl.handle.net/2027/umn.31951d00326543q?urlappend=%3Bseq=149>.

Kuhn, Thomas S. *The Essential Tension: Selected Studies in Scientific Tradition and Change*. Chicago: The University of Chicago Press, 1977.

Kuhn, Thomas S. "The Essential Tension: Tradition and Innovation in Scientific Research." In *The Essential Tension: Selected Studies in Scientific Tradition and Change*, by Thomas S. Kuhn, 225-239. Chicago: The University of Chicago Press, 1977.

Kuhn, Thomas S. "The Function of Measurement in Modern Physical Science." In *The Essential Tension: Selected Studies in Scientific Tradition and Change*, by Thomas S. Kuhn, 178-224. Chicago: The University of Chicago Press, 1977.

Kuhn, Thomas S. *The Structure of Scientific Revolutions*. 3<sup>rd</sup> ed. Chicago: The University of Chicago Press, 1996.

Ladenburg, A. *Lectures on the History of the Development of Chemistry since the Time of Lavoisier*. From the 2<sup>nd</sup> German edition. Translated by Leonard Dobbin. Edinburgh: The Alembic Club, 1900.  
<https://books.google.com/books?vid=HARVARD:32044058223652>.

Lagerkvist, Ulf. *The Periodic Table and a Missed Nobel Prize*. Hackensack, NJ: World Scientific, 2012.

Lalanne, Léon. "Mémoire sur les tables graphiques et sur la géométrie anamorphique appliquée à diverses questions qui se rattachent à l'art de l'ingénieur." *Annales des Ponts et des Chaussées* 11 (1846): 1-69.  
<https://hdl.handle.net/2027/hvd.hw1wet?urlappend=%3Bseq=13>.

Lankester, E. Ray. "Address." In *Report of the Seventy-Sixth Meeting of the British Association for the Advancement of Science, York, August 1906*, 3-42. London: John Murray, 1907. <https://biodiversitylibrary.org/page/29741603>.

Laurent, August. *Chemical Method, Notation, Classification, & Nomenclature*. Translated by William Odling. London: Harrison and Sons, 1855.  
<https://books.google.com/books?id=xyJT5z0t8j8C>.

Lavine, Matthew. *The First Atomic Age: Scientists, Radiations, and the American Public, 1895-1945*. New York: Palgrave Macmillan, 2013.

Lavoisier. *Elements of Chemistry*. Translated by Robert Kerr. Edinburgh, 1790.  
<https://hdl.handle.net/2027/gri.ark:/13960/t5v735k9h>.

Lavoisier. *Traité élémentaire de chimie*. Paris: Chez Cuchet, 1789.  
<https://hdl.handle.net/2027/mdp.39015005319481>.

Lehman, Jeffrey Richard. "Interaction of Learner Characteristics with Learning from Analogical Models of the Periodic Table and Written Texts." PhD Diss., University of Florida, 1982. <https://archive.org/details/interactionoflea00lehm>.

Leicester, Henry M., and Herbert S. Klickstein, ed. *A Source Book in Chemistry, 1400-1900*. Cambridge, MA: Harvard University Press, 1952.

Leigh, G. Jeffery. "Periodic Tables and IUPAC." *Chemistry International* 31, no. 1 (2009): 4-6. doi: 10.1515/ci.2009.31.1.4.

Leigh, G. J., ed. *Nomenclature of Inorganic Chemistry: Recommendations 1990*. Oxford: Blackwell Scientific Publications, 1990.

Lengyel, Béla v. "On Radio-active Barium." *Chemical News* 82 (1900): 25-26.  
<https://hdl.handle.net/2027/njp.32101075380020?urlappend=%3Bseq=33>.

LeRoy, Royce H. "Teaching the Periodic Classification of Elements." *School Science and Mathematics* 27 (1927): 793-799.

Lloyd, H. H. "General Chemistry." Review of *General Chemistry*, by H. G. Deming. *Journal of Chemical Education* 2 (1925): 226. doi:10.1021/ed002p226.1.

Lloyd, H. H. "General Chemistry." Review of *General Chemistry*, by H. G. Deming. *Journal of Chemical Education* 3 (1926): 119. doi:10.1021/ed003p119.3.

Lockyer, J. N. "Researches in Spectrum Analysis in Connexion With the Spectrum of the Sun. No. VII." *Proceedings of the Royal Society of London* 28 (1878-1879): 157-180. <http://www.jstor.org/stable/113812>.

Lodge, Oliver, and R. J. Strutt. "Radium." *Times* (London). August 15, 1906: 4.

Lormand, Charles. "The International Chemical Conference." *Journal of Industrial and Engineering Chemistry* 12 (1920): 925-926. doi:10.1021/ie50129a030.

Lormand, Charles. "The Second International Chemical Conference." *Journal of Industrial and Engineering Chemistry* 13 (1921): 737-738.  
doi:10.1021/ie50140a031.

Lundgren, Anders, and Bernadette Bensaude-Vincent, ed. *Communicating Chemistry: Textbooks and Their Audiences, 1789-1939*. Canton, MA: Science History Publications, 2000.

Macquer, Pierre Joseph. *A Dictionary of Chemistry*. 2<sup>nd</sup> ed. Vol. 1. London: 1777.  
<https://archive.org/details/dictionaryofchem01macq>.

Marchese, Francis T. "Periodicity, Visualization, and Design." *Foundations of Chemistry* 15 (2013): 31-55. doi: 10.1007/s10698-012-9154-0.

Marignac, C. "Quelques Réflexions Sur le Groupe des Terres Rares a Propos de la Théorie de M. Crookes sur la Genèse des Éléments." *Archives des Sciences Physiques et Naturelles* 17 (1887): 373-389.  
<https://hdl.handle.net/2027/njp.32101033964477?urlappend=%3Bseq=381>.

Marignac, C. "Recherches sur les Rapports Réciproques des les Poids Atomique par M. J.-S. Stas." *Archives des Sciences Physiques et Naturelles*, 2<sup>nd</sup> ser., 9 (1870): 97-107.  
<https://hdl.handle.net/2027/njp.32101033964915?urlappend=%3Bseq=463>.

Marsh, J. E. "William Odling." *Journal of the Chemical Society, Transactions* 119 (1921): 553-564. doi:10.1039/CT9211900529

Marshall, Hugh. "Inorganic Chemistry." *Annual Reports on the Progress of Chemistry* 5 (1908): 31-72. doi:10.1039/AR9080500031.

Mazurs, Edward G. *Graphic Representations of the Periodic System During One Hundred Years*. Revised (2<sup>nd</sup>) ed. of *Types of Graphic Representation of the Periodic System of Chemical Elements*, LaGrange, IL: 1957. University, AL: The University of Alabama Press, 1974.

McPherson, William and William Edwards Henderson. *A Course in General Chemistry*. 2<sup>nd</sup> ed. Boston: Ginn and Company, 1921.

Meinel, Christoph. "Structural Changes in International Scientific Communication: The Case of Chemistry." In *Atti del V Convegno Nazionale di Storia e Fondamenti della Chimica*, edited by Gianlorenzo Marino, 47-61. Rome: Accademia Nazionale delle Scienze, 1994. <http://nbn-resolving.de/urn/resolver.pl?urn=urn:nbn:de:bvb:355-epub-135639>.

Mellor, J. W. *A Comprehensive Treatise on Inorganic and Theoretical Chemistry*. vol. 1 London: Longmans, Green, and Co., 1922.

Mellor, J. W. *A Comprehensive Treatise on Inorganic and Theoretical Chemistry*. vol. 4 London: Longmans, Green, and Co., 1923.

Mellor, J. W. *Modern Inorganic Chemistry*. London: Longmans, Green, and Co., 1912. [https://hdl.handle.net/2027/uc1.\\$b277859](https://hdl.handle.net/2027/uc1.$b277859).

"Memorandum of Committee on International Scientific Organisations." *Chemical News* 117 (1918): 283-287, 311-313. <https://hdl.handle.net/2027/mdp.39015073139654?urlappend=%3Bseq=339>.

Mendeleef, D. "The Periodic Law of the Chemical Elements." *Chemical News* 40 (1879): 231-232, 243-244, 255-256, 267-268, 279-280, 291-292, 303-304; 41 (1880): 2-3, 27-28, 39-40, 49-50, 61-62, 71-72, 83-84, 93-94, 106-108, 113-114, 125-126. <https://hdl.handle.net/2027/wu.89100444694?urlappend=%3Bseq=241>; <https://hdl.handle.net/2027/mdp.39015073203989?urlappend=%3Bseq=10>.

Mendeleeff, D. "La Loi Périodique des Éléments Chimiques." *Le Moniteur Scientifique*, 3<sup>rd</sup> ser., 9 (1879): 691-737. <https://gallica.bnf.fr/ark:/12148/bpt6k215202c/f690.item>.

Mendeléeff. "The Periodic Law of the Chemical Elements." *Journal of the Chemical Society. Transactions* 55 (1889): 634-656. doi:10.1039/CT8895500634.

Mendeleeff, D. *An Attempt Towards a Chemical Conception of the Ether*. Translated by George Kamensky. London: Longmans, Green, and Co., 1904.  
<https://books.google.com/books?id=9dlygNQjvn0C>.

Mendeléeff, D. *The Principles of Chemistry*. From the 5<sup>th</sup> Russian ed. Translated by George Kamensky. Edited by A. J. Greenaway. London: Longmans, Green, and Co., 1891. <https://books.google.com/books?vid=HARVARD:HWSSDG>;  
<https://books.google.com/books?vid=HARVARD:HWSSE6>.

Mendeleeff, D. "Remarques à propos de la découverte du gallium." *Comptes Rendus Hebdomadaires des Séances de l'Académie des Sciences* 81 (1875): 969-972.  
<https://hdl.handle.net/2027/uc1.31822009517228?urlappend=%3Bseq=977>.

Mendeleev, D. "Estestvennaya sistema elementov i prmeninie ee k ukazaniyu svoistv neotkrytykh elemntov." *Zhurnal Russkogo Khimicheskogo Obshchestva* 3 (1870): 25-56. [https://hdl.handle.net/2027/uc1.\\$b625236?urlappend=%3Bseq=39](https://hdl.handle.net/2027/uc1.$b625236?urlappend=%3Bseq=39).

Mendeleev, D. "Sootnoshenie svoistv s atomnym vesom elemntov." *Zhurnal Russkogo Khimicheskogo Obshchestva* 1 (1869): 60-77.  
[https://hdl.handle.net/2027/uc1.\\$b625235?urlappend=%3Bseq=70](https://hdl.handle.net/2027/uc1.$b625235?urlappend=%3Bseq=70).

Mendeleev, Dmitri. *Mendeleev on the Periodic Law: Selected Writings, 1869-1905*. Edited by William B. Jensen. Mineola, NY: Dover Publications, Inc., 2002.

Mendeleev, Dmitri. "On the Correlation Between the Properties of the Elements and Their Atomic Weights." In *Mendeleev on the Periodic Law: Selected Writings, 1869-1905*, by Dmitri Mendeleev, 18-37. Mineola, NY: Dover Publications, Inc., 2002.

Mendelejeff, D. "Die periodische Gesetzmäßigkeit der chemischen Elemente." *Annalen der Chemie*, supp. 8 (1871): 133-229.  
<https://books.google.com/books?id=vpJbtTjj8ZYC>.

Mendelejeff, D. "Remarks on the Discovery of Gallium." *Philosophical Magazine*, 5<sup>th</sup> ser., 1 (1876): 542-546.  
<https://hdl.handle.net/2027/njp.32101075715175?urlappend=%3Bseq=564>.

Mercer, John. "On the Relation of the Atomic Weights of the Families of the Elements." In *Report of the Twenty-Eighth Meeting of the British Association for the Advancement of Science*, 57-63. London: John Murray, 1859.  
<https://biodiversitylibrary.org/page/30570462>.

Merrill, Richard J., and David W. Ridgway. *The CHEM Study Story*. San Francisco: W. H. Freeman and Company, 1969.  
<https://archive.org/details/chemstudystory00merr>.

Meusel, Eduard. *Der Monismus der chemischen Elemente*. Liegnitz: Ewald Scholz, 1893. <https://books.google.com/books?id=uDNDAAAIAAJ>.

Meyer, Julius Lothar. "The Nature of the Chemical Elements as a Function of Their Atomic Weights." In *A Source Book in Chemistry, 1400-1900*, edited by Henry M. Leicester and Herbert S. Klickstein, 434-438. Cambridge, MA: Harvard University Press, 1952.

Meyer, Lothar. *Modern Theories of Chemistry*. 5<sup>th</sup> German ed. Translated by P. Phillips Bedson and W. Carleton Williams. London: Longmans, Green, and Co., 1888. <https://books.google.com/books?id=f2U6AAAAMAAJ>.

Meyer, Lothar. *Die modernen Theorien der Chemie und ihre Bedeutung für die chemische Statik*. Breslau: Maruschke & Berendt, 1864. <https://books.google.com/books?id=pLg5AAAACAAJ>.

Meyer, Lothar. "Die Natur der chemischen Elemente als Function ihrer Atomgewichte." *Annalen der Chemie*, supp. 7 (1870): 354-364. <https://hdl.handle.net/2027/mdp.39015026326531?urlappend=%3Bseq=364>.

Meyer, Lothar. "Ueber den Vortrag der anorganischen Chemie nach dem natürlichen Systeme der Elemente." *Berichte der deutschen chemischen Gesellschaft* 26 (1893): 1230-1250. <https://hdl.handle.net/2027/uc1.b3481864?urlappend=%3Bseq=62>.

Meyer, Lothar, and Karl Seubert. *Die Atomgewichte der Elemente aus den Originalzahlen neu berechnet*. Leipzig: Breitkopf and Härtel, 1883. <https://books.google.com/books?id=JnEMAQAIAAJ>.

Miller, William Allen. *Elements of Chemistry: Theoretical and Practical*. Pt. 2. London: John W. Parker and Son, 1856. <https://archive.org/details/elemchemistry02millrich>.

Miller, William Allen. *Elements of Chemistry: Theoretical and Practical*. 6<sup>th</sup> ed., Pt. 2. Revised by Charles E. Groves. London: Longmans, Green, Reader, and Dyer, 1878. <https://archive.org/details/elemofchemis02millrich>.

Mills, Edmund J. "On Melting-point and Boiling-point as Related to Chemical Composition." *Philosophical Magazine*, 5<sup>th</sup> ser., 17 (1884): 173-187. <https://hdl.handle.net/2027/wu.89048311823?urlappend=%3Bseq=185>.

Milojevic, Stasa, Cassidy R. Sugimoto, Vincent Larivière, Mike Thelwall, and Ying Ding. "The Role of Handbooks in Knowledge Creation and Diffusion: A Case of Science and Technology Studies." *Journal of Informetrics* 8 (2014): 693-709. doi:10.1016/j.joi.2014.06.003.



Moissan, Henri, and François Dupont. *Ive Congrès International de Chimie Appliquée: Compte Rendu In-Extenso*. Vol. 1. Paris: L'Association des Chimistes de Sucreie et de Distillerie, 1902. <https://hdl.handle.net/2027/mdp.39015078144402>.

Monckman, James. "On a Natural System of Arranging the Chemical Elements, In Which They Fall Into the Periodic Groups, Based Solely Upon the Atomic Volumes and the Combining Weights." *Chemical News* 95 (1907): 5-9. <https://hdl.handle.net/2027/mdp.39015073138953?urlappend=%3Bseq=21>.

Montgomery, Scott L. *Science in Translation: Movements of Knowledge Through Cultures and Time*. Chicago: The University of Chicago Press, 2000.

Moseley, H. G. J. "High-Frequency Spectra." In *Report of the Eighty-Fourth Meeting of the British Association for the Advancement of Science, Australia, 1914*, 305. London: John Murray, 1915. <https://biodiversitylibrary.org/page/30399800>.

Moseley, H. G. J. "The High-Frequency Spectra of the Elements." *Philosophical Magazine*, 6<sup>th</sup> ser., 26 (1913): 1024-1034. <https://archive.org/details/londonedinburg6261913lond>.

Moseley, H. G. J. "The High-Frequency Spectra of the Elements. Part II." *Philosophical Magazine*, 6<sup>th</sup> ser., 27 (1914): 703-713. <https://archive.org/details/londonedinburg6271914lond>.

"The Most Notable School Books of 1909." *The School World* 12 (1910): 20-23. [https://books.google.com/books?id=\\_pOgAAAAMAAJ](https://books.google.com/books?id=_pOgAAAAMAAJ).

Murphy, Craig N., and JoAnne Yates. *The International Organization for Standardization (ISO): Global Governance Through Voluntary Consensus*. New York: Routledge, 2009.

"The Nature of the Elements." *Chemical News* 38 (1878): 291-292. <https://hdl.handle.net/2027/inu.30000088771401?urlappend=%3Bseq=583>.

Nernst, Walter. *Theoretical Chemistry From the Standpoint of Avogadro's Rule & Thermodynamics*. 2<sup>nd</sup> English ed., revised in accordance with the 4<sup>th</sup> German ed. London: Macmillan and Co., Limited, 1904. [https://hdl.handle.net/2027/uc1.\\$b35677](https://hdl.handle.net/2027/uc1.$b35677).

"The New Science – Atomechanics." Review of *Programme der atomechanik oder die chemie eine mechanik der panatome*, by Gustavus Hinrichs. *Mechanics' Magazine*, n.s., 18 (1867): 424.

Newell, Lyman C. *Descriptive Chemistry*. Revised ed. Boston: D. C. Heath & Co., Publishers, 1909. <https://books.google.com/books?vid=HARVARD:32044097019756>.

Newlands, John A. R. "On Relations Among the Equivalentents." *Chemical News* 10 (1864): 94-95.

<https://hdl.handle.net/2027/njp.32101075379055?urlappend=%3Bseq=382>.

Newlands, John A. R. *On the Discovery of the Periodic Law, and On Relations Among the Atomic Weights*. London: E. & F. N. Spon, 1884.

<https://books.google.com/books?id=OysKESmPLNEC>.

Newlands, John A. R. "On the Law of Octaves." *Chemical News* 12 (1865): 83.

<https://hdl.handle.net/2027/njp.32101075379063?urlappend=%3Bseq=407>.

Newlands, John A. R. "On the 'Law of Octaves'." *Chemical News* 13 (1866): 130.

<https://hdl.handle.net/2027/njp.32101075379071?urlappend=%3Bseq=130>.

Newlands, John A. R. "Relations Between Equivalentents." *Chemical News* 10 (1864): 59-60.

<https://hdl.handle.net/2027/njp.32101075379055?urlappend=%3Bseq=347>.

Newth, G. S. *A Text-book of Inorganic Chemistry*. New ed. London: Longmans, Green and Co., 1909. <https://hdl.handle.net/2027/uc1.b4059214>.

Nicholson, J. W. "The High-Frequency Spectra of the Elements, and the Structure of the Atom." *Philosophical Magazine*, 6<sup>th</sup> ser., 27 (1914): 541-564.

<https://archive.org/details/londonedinburg6271914lond>.

Nieto-Galan, Agustí. *Science in the Public Sphere: A History of Lay Knowledge and Expertise*. Translated by Fiona Kelso. New York: Routledge, 2016.

Nilson, L. F. "Ueber Scandium, ein neues Erdmetall." *Berichte der deutschen chemischen Gesellschaft* 12 (1879): 554-557.

<https://hdl.handle.net/2027/umn.31951000682712e?urlappend=%3Bseq=620>.

Nilson, L. F., and Otto Pettersson, "On the Essential Properties and Chemical Character of Beryllium (Glucinum)." *Chemical News* 42 (1880): 297-299.

<https://hdl.handle.net/2027/njp.32101075379477?urlappend=%3Bseq=307>.

"Notes." *Nature* 73 (1905): 105-109. doi:10.1038/073105b0.

Nye, Mary Jo. *Before Big Science: The Pursuit of Modern Chemistry and Physics, 1800-1940*. Cambridge, MA: Harvard University Press, 1996.

Nye, Mary Jo. "Nonconformity and Creativity: A Study of Paul Sabatier, Chemical Theory, and the French Scientific Community." *Isis* 68 (1977): 375-391.

<http://www.jstor.org/stable/231314>.

Nye, Mary Jo, ed. *The Modern Physical and Mathematical Sciences*. Vol. 5 of *Cambridge History of Science*. Cambridge: Cambridge University Press, 2002.

Nye, Mary Jo, ed. *The Question of the Atom: From the Karlsruhe Congress to the First Solvay Conference, 1860-1911*. Los Angeles: Tomash Publishers, 1984.

Odling, William. *Cours de Chimie Pratique (Analytique, Toxocologique, Animale) a l'Usage des Étudiants en Médecine*. Translated from the 3<sup>rd</sup> ed. by A. Naquet. Paris: F. Savy, 1869. <https://hdl.handle.net/2027/ucm.5321310309>.

Odling, William. *A Course of Practical Chemistry Arranged for the Use of Medical Students*. 2<sup>nd</sup> ed. London: Longmans, Green, and Co., 1865. <https://books.google.com/books?id=f49JAAAAYAAJ>.

Odling, William. *A Manual of Chemistry: Descriptive and Theoretical*. London: Longman, Green, Longman, and Roberts, 1861. [https://hdl.handle.net/2027/uc1.\\$b35374](https://hdl.handle.net/2027/uc1.$b35374).

Odling, William. "On the Natural Groupings of the Elements." *Philosophical Magazine*, 4<sup>th</sup> ser., 13 (1857): 423-439, 480-497. <https://hdl.handle.net/2027/njp.32101076464641?urlappend=%3Bseq=441>; <https://hdl.handle.net/2027/njp.32101076464641?urlappend=%3Bseq=498>.

Odling, William. "On the Proportional Numbers of the Elements." *Quarterly Journal of Science* 1 (1864): 642-648. <https://hdl.handle.net/2027/mdp.39015013721371?urlappend=%3Bseq=694>.

Odling, William. *Tables of Chemical Formulæ*. London: Taylor and Francis, 1864. <https://archive.org/details/b22299452>.

P., A. W. "Physics at the British Association." *Nature* 74 (1906): 453-456. doi:10.1038/074453a0.

Palmer, W. P. "Dissent at the University of Iowa: Gustavus Detlev Hinrichs – Chemist and Polymath." *Khymia / Chemistry: Bulgarian Journal of Science Education* 16 (2007): 534-553.

Paneth, F. A. "Chemical Elements and Primordial Matter: Mendelleef's View and the Present Position." In *Chemistry and Beyond: A Selection From the Writings of the Late Professor F. A. Paneth*, by F. A. Paneth, 53-72. New York: Interscience Publishers, 1964. Translation of "Chemische Elemente und Urmaterie: Mendeleevs Ansicht und der heutige Standpunkt." *Travaux du Congrès Jubilaire Mendéléév*. Leningrad: Académie des Sciences de l'U.S.S.R., 1936.

Paneth, F. A. *Chemistry and Beyond: A Selection from the Writings of the Late Professor F. A. Paneth*. Edited by Herbert Dingle and G. R. Martin. New York: Interscience Publishers, 1964.

Paneth, F. A. "The Epistemological Status of the Chemical Concept of the Element." *British Journal for the Philosophy of Science* 13 (1962): 1-14, 144-160.  
<http://www.jstor.org/stable/685220>; <http://www.jstor.org/stable/685967>.

Paneth, F. A. "A Tribute to Lothar Meyer on the Centenary of his Birth." In *Chemistry and Beyond: A Selection from the Writings of the Late Professor F. A. Paneth*, by F. A. Paneth, 51-52. New York: Interscience Publishers, 1964. Translation of "Zur hundertsten Wiederkehr von Lothar Meyers Geburtstag." *Forschung und Fortschritt* 6 (1930): 329.

Paneth, Fritz. *Radio-Elements as Indicators and Other Selected Topics in Inorganic Chemistry*. New York: McGraw-Hill Book Company, Inc., 1928.

Paneth, Fritz. "Über den Element- und Atombegriff in Chemie und Radiologie." *Zeitschrift für Physikalische Chemie* 91 (1916): 171-198.  
<https://hdl.handle.net/2027/umn.31951000633920w?urlappend=%3Bseq=181>.

Paneth, Fritz. "Über die heutige Schreibweise des periodischen Systems der Elemente." *Zeitschrift für angewandte Chemie* 36 (1923): 407-410.  
[doi:10.1002/ange.19230365707](https://doi.org/10.1002/ange.19230365707).

Parnell, Edward A. *The Life and Labours of John Mercer, F.R.S., F.C.S., etc.* London: Longmans, Green, and Co., 1886.  
<https://books.google.com/books?id=sRguAAAAYAAJ>.

Parsons, Charles Lathrop. *The Chemistry and Literature of Beryllium*. Easton, PA: The Chemical Publishing Co., 1909.  
<https://books.google.com/books?id=7MxAAAAIAAJ>.

Pattison Muir, M. M. *A History of Chemical Theories and Laws*. New York: John Wiley & Sons, 1909. <https://hdl.handle.net/2027/mdp.39015078650713>.

Pattison Muir, M. M. "Observations on Gallium." *Philosophical Magazine*, 5<sup>th</sup> ser., 3 (1877): 281-283.  
<https://hdl.handle.net/2027/wu.89048311674?urlappend=%3Bseq=293>.

Pattison Muir, M. M. "On Chemical Classification." *Philosophical Magazine*. 5<sup>th</sup> ser., 4 (1877): 81-99, 187-206, 257-271.  
<https://hdl.handle.net/2027/wu.89048311682?urlappend=%3Bseq=93>.

Pattison Muir, M. M. "On the Teaching of Chemistry." *Nature* 36 (1887): 536-538.  
[doi:10.1038/036536a0](https://doi.org/10.1038/036536a0).

Pattison Muir, M. M. "Professor Lothar Meyer." *Scientific American Supplement* 40 (1895): 16271-16272.

<https://hdl.handle.net/2027/uc1.31210014472623?urlappend=%3Bseq=13>.

Petryanov, I. V., and D. N. Trifonov. *Elementary Order: Mendeleev's Periodic System*. Trans. by Nicholas Weinstein. Moscow: Mir Publishers, 1984. Revised from the Russian ed., 1976.

Pfeiffer, Paul. "Die Befruchtung der Chemie durch die Röntgenstrahlenphysik." *Naturwissenschaften* 8 (1920): 984-991. doi:10.1007/BF02448807.

Pienta, Norbert J. "Editor's Note." *Journal of Chemical Education* 87 (2010): 783. doi:10.1021/ed100436f.

Poliakoff, Martyn, and Samantha Tang. "The Periodic Table: Icon and Inspiration," *Philosophical Transactions of the Royal Society A* 373 (2016): 20140211. doi:10.1098/rsta.2014.0211.

"Preliminary Report of the Inter-Allied Conference on International Scientific Organisations." *Chemical News* 117 (1918): 351-352. <https://hdl.handle.net/2027/mdp.39015073139654?urlappend=%3Bseq=415>.

Preyer, W. *Die Organischen Elemente und ihre Stellung im System*. Weisbaden: J. F. Bergmann, 1891. <https://books.google.com/books?id=QYBZAAAAYAAJ>.

"Proceedings of the Societies - Chemical Society." *Chemical News* 13 (1866): 113-114. <https://hdl.handle.net/2027/njp.32101075379071?urlappend=%3Bseq=113>.

"Professor Thomas Carnelley." *Chemical News* 62 (1890): 126. <https://hdl.handle.net/2027/inu.30000088771088?urlappend=%3Bseq=458>.

"A Programme of Atomechanics." Review of *Programme der atomechanik oder die chemie eine mechanik der panatome*, by Gustavus Hinrichs. *Chemical News* 16 (1867): 289-290. <https://hdl.handle.net/2027/njp.32101075379089?urlappend=%3Bseq=667>.

[Prout, William.] "Correction of a Mistake in the Essay on the Relation Between the Specific Gravities of Bodies in Their Gaseous State and the Weights of Their Atoms." *Annals of Philosophy* 7 (1816): 111-113. [https://hdl.handle.net/2027/uc1.\\$b526642?urlappend=%3Bseq=143](https://hdl.handle.net/2027/uc1.$b526642?urlappend=%3Bseq=143).

[Prout, William.] "On the Relations Between the Specific Gravities of Bodies in Their Gaseous State and the Weight of Their Atoms." *Annals of Philosophy* 6 (1815): 321-330. [https://hdl.handle.net/2027/uc1.\\$b526641?urlappend=%3Bseq=345](https://hdl.handle.net/2027/uc1.$b526641?urlappend=%3Bseq=345).

Pyykkö, Pekka. "Is the Periodic Table All Right ('PT OK')?." Nobel Symposium NS160 – Chemistry and Physics of Heavy and Superheavy Elements. *EPJ Web of Conferences* 131, 01001 (2016). doi: 10.1051/epjconf/201613101001.

Quam, G. N., and Mary Battell Quam, "Types of Graphic Classifications of the Elements." *Journal of Chemical Education* 11 (1934): 27-32, 217-223, 288-297. doi:10.1021/ed011p27; 10.1021/ed011p217; 10.1021/ed011p288.

R., H. E., and P. P. B. "Thomas Carnelley." *Nature* 42 (1890): 522-523. doi:10.1038/042522b0.

"Radio-activity." *Chemical News* 94 (1906): 125. <https://hdl.handle.net/2027/wu.89099510216?urlappend=%3Bseq=407>.

Ramsay, William. "The Electron as an Element." *Journal of the Chemical Society, Transactions* 93 (1908): 774-788. doi: 10.1039/CT9089300774.

Ramsay, William. "The International Association of Chemical Societies." *Nature* 92 (1913): 453-454. doi:10.1038/092453a0.

Ramsay, William. "President's Address." In *Report of the Eighty-First Meeting of the British Association for the Advancement of Science*, 3-22. London: John Murray, 1912. <https://biodiversitylibrary.org/page/29843514>.

Ramsay, William. "The Recently Discovered Gases and Their Relation to the Periodic Law." *Science*, n.s., 9 (1899): 273-280. <http://www.jstor.org/stable/1626430>.

Ramsay, William. "An Undiscovered Gas." *Chemical News* 76 (1897): 91-93, 97-99. <https://hdl.handle.net/2027/wu.89099510240?urlappend=%3Bseq=99>.

Ramsay, William, J. Norman Collie, and Morris Travers. "Helium, A Constituent of Certain Minerals." *Nature* 52 (1895): 306-308, 331-334. doi:10.1038/052306b0; doi:10.1038/052331a0.

Ramsay, William, and Morris W. Travers. "Argon and Its Companions." *Nature* 63 (1900): 164-165. doi:10.1038/063164a0.

Ramsay, William, and Morris W. Travers. "Argon and Its Companions." *Philosophical Transactions of the Royal Society of London* 197A (1901): 47-89. <http://www.jstor.org/stable/90832>.

Rang, F. "The Period-Table." *Chemical News* 72 (1895): 200-201. <https://hdl.handle.net/2027/inu.30000088771047?urlappend=%3Bseq=538>.

Rang, P. J. F. "The Periodic Arrangement of the Elements." *Chemical News* 67 (1893): 178. <https://hdl.handle.net/2027/inu.30000088771062?urlappend=%3Bseq=186>.

- Rawls, Rebecca. "Revisions to Periodic Table Spark Controversy." *Chemical & Engineering News* 64, no. 4 (1986): 22-24.
- Rayleigh, Lord. "On Dr. Johnstone Stoney's Logarithmic Law of Atomic Weights." *Proceedings of the Royal Society of London* 85A (1911): 471-473.  
<http://www.jstor.org/stable/93280>.
- Rayleigh, Lord, and William Ramsay. "Argon, A New Constituent of the Atmosphere." *Philosophical Transactions of the Royal Society of London* 186A (1895): 187-241.  
<http://www.jstor.org/stable/90645>.
- Rayleigh, Lord, and William Ramsay. "Argon, A New Constituent of the Atmosphere. [Abstract]." *Proceedings of the Royal Society of London* 57 (1894-1895): 265-287.  
<http://www.jstor.org/stable/115394>.
- Regnault, V. *Cours Élémentaire de Chimie*. Volume 1, 5<sup>th</sup> ed. Paris: L. Langlois; Victor Masson, 1859. <https://books.google.com/books?id=hiUMAQAIAAJ>.
- Regnault, V. *Elements of Chemistry*. Translated by T. Forrest Betton. Volume 1. Philadelphia: Henry Carey Baird, 1865.  
<https://books.google.com/books?id=WQxDAAAIAAJ>.
- Regnault, Victor, and Adolph Strecker. *Regnault-Strecker's Kurze Lehrbuch der chemie*. Volume 1. Braunschweig: Friedrich Viewig und Sohn, 1864.  
<https://books.google.com/books?id=4K05AAAAcAAJ>.
- Reinhardt, Carsten, ed. *Chemical Sciences in the 20<sup>th</sup> Century: Bridging Boundaries*. Weinheim: Wiley-VCH, 2001.
- Reinmuth, Otto. "Handbook of Chemistry and Physics." Review of *Handbook of Chemistry and Physics*, edited by Charles D. Hodgman. *Journal of Chemical Education* 12 (1935): 50. doi:10.1021/ed012p50.4.
- Remsen, Ira. *A College Text-book of Chemistry*. 2<sup>nd</sup> ed., revised. New York: Henry Holt and Company, 1909. <https://books.google.com/books?vid=HARVARD:HW3ERO>.
- Remsen, Ira. *An Introduction to the Study of Chemistry*. 8<sup>th</sup> ed., revised and enlarged. New York: Henry Holt and Company, 1909.  
<https://hdl.handle.net/2027/mdp.39015064485876>.
- Rennie, E. H. "Chemistry and Mineralogy." *Chemical News* 62 (1890): 45-47, 53-55.  
<https://hdl.handle.net/2027/inu.30000088771088?urlappend=%3Bseq=377>.
- Reychler, A. *Les théories physico-chimiques*. 3<sup>rd</sup> ed. Bruxelles: H. Lamertin, 1903.  
<https://books.google.com/books?id=k1wvQAAMAAJ>.

Reynolds, J. Emerson. "Note on a Method of Illustrating the Periodic Law." *Chemical News* 54 (1886): 1-4.

<https://hdl.handle.net/2027/wu.89081861098?urlappend=%3Bseq=19>.

Richards, Theodore W. "Atomic Weights." *Journal of the American Chemical Society* 34 (1912): 959-971. doi:10.1021/ja02209a001.

Roca-Rosell, A., ed. *The Circulation of Science and Technology: Proceedings of the 4<sup>th</sup> International Conference of the ESHS*. Barcelona: SCHCT-IEC, 2012.

[http://4eshs.iec.cat/entrada.asp?epigraf\\_contingut=18](http://4eshs.iec.cat/entrada.asp?epigraf_contingut=18).

Rocke, Alan J. *Chemical Atomism in the Nineteenth Century: From Dalton to Cannizzaro*. Columbus: Ohio State University Press, 1984.

Rocke, Alan J. *The Quiet Revolution: Hermann Kolbe and the Science of Organic Chemistry*. Berkeley: University of California Press, 1993.

Roqué, Xavier. "Displacing Radiochemistry." In *Instrumentation Between Science, State and Industry*, edited by Bernward Joerges and Terry Shinn, 51-68. Dordrecht: Kluwer Academic Publishers, 2001.

Roqué, Xavier. "From Radiochemistry to Nuclear Chemistry to Cosmochemistry." In *Chemical Sciences in the 20<sup>th</sup> Century: Bridging Boundaries*, edited by Carsten Reinhardt, 121-130. Weinheim: Wiley-VCH, 2001.

Rosen, B. *In the Realm of Large Molecules*. Moscow: Foreign Languages Publishing House, [1958-1965].

Ross, William H., and H. Jermain Creighton. "A Plea for Uniformity in Radio-active Nomenclature." *Nature* 91 (1913): 347. doi:10.1038/091347a0.

Rudolph, John L. "Historical Writing on Science Education: A View of the Landscape." *Studies in Science Education* 44 (2008): 63-82.

Rudolph, John L. "Teaching Materials and the Fate of Dynamic Biology in American Classrooms after Sputnik." *Technology & Culture* 53 (2012): 1-36. doi:10.1353/tech.2012.0037.

Rudorf, George. *The Periodic Classification and the Problem of Chemical Evolution*. London: Whittaker & Co., 1900. [https://hdl.handle.net/2027/uc1.\\$b242304](https://hdl.handle.net/2027/uc1.$b242304).

Rudorf, George. *Das periodische System, seine Geschichte und Bedeutung für die chemie Systematik*. Hamburg: Leopold Voss, 1904. <https://books.google.com/books?id=sF8MAQAIAAJ>.



Runge, C., and J. Precht. "The Position of Radium in the Periodic System According to Its Spectrum." *Philosophical Magazine*, 6<sup>th</sup> ser., 5 (1903): 476-481.  
<https://hdl.handle.net/2027/njp.32101075715449?urlappend=%3Bseq=512>.

Runge, C., and J. Precht. "Die Stellung des Radium im periodischen System nach seinem Spektrum." *Physikalische Zeitschrift* 4 (1902-1903): 285-287.  
<https://hdl.handle.net/2027/njp.32101054770811?urlappend=%3Bseq=313>.

Rutherford, E. "The Origin of Radium." *Nature* 76 (1907): 661.  
doi:10.1038/076661b0.

Rutherford, E. "Properties of Polonium." *Nature* 82 (1910): 491-492.  
doi:10.1038/082491a0.

Rutherford, E. *Radioactive Transformations*. New York: Charles Scribner's Sons, 1906. <https://books.google.com/books?vid=HARVARD:32044106201734>.

Rutherford, E. "The Recent Radium Controversy." *Nature* 74 (1906): 634-635.  
doi:10.1038/074634b0.

Rutherford, E. "The Scattering of  $\alpha$  and  $\beta$  Particles by Matter and the Structure of the Atom." *Philosophical Magazine*. 6<sup>th</sup> ser., 21 (1911): 669-688.  
<https://archive.org/details/londonedinburg6211911lond>.

Rutherford, E., and F. Soddy. "Radioactive Change." *Philosophical Magazine*. 6<sup>th</sup> ser., 5 (1903): 576-591.  
<https://hdl.handle.net/2027/njp.32101075715449?urlappend=%3Bseq=618>.

Rydberg, J. R. *Elektron der erste Grundstoff*. Lund: Hakan Ohlssons Buchdruckerei, 1906. <https://books.google.com/books?id=BZIoAQAAMAAJ>.

Rydberg, J. R. "Om de Kemiska Grundämnenas Periodiska System." *Bihang till Kongl. Svenska vetenskaps-akademiens handlingar* 10, no. 2 (1885): 1-31.  
<https://hdl.handle.net/2027/hvd.32044106419278?urlappend=%3Bseq=75>.

Sabatier, Paul. "Sur la classification des corps simples par la loi périodique." *Annales de la Faculté des Sciences de Toulouse* 4 (1890): B.1-B.14.  
<https://hdl.handle.net/2027/njp.32101043993706?urlappend=%3Bseq=27>.

Sakurai, Joji, and K. Ikeda. "International Atomic Weights." *Chemical News* 89 (1904): 305.  
<https://hdl.handle.net/2027/mdp.39015073139126?urlappend=%3Bseq=311>.

Saltzman, Martin D. "Chemical Societies and Their Journals: What Can Be Learned About the State of Chemistry From an Analysis of the First Volumes of These Journals." *Bulletin for the History of Chemistry* 31 (2006): 19-27.  
[http://www.scs.illinois.edu/~mainzv/HIST/bulletin\\_open\\_access/bull-index.php](http://www.scs.illinois.edu/~mainzv/HIST/bulletin_open_access/bull-index.php).

Sanderson, R. T. "Woes With the Periodic Table." *Chemical & Engineering News* 63, no. 10 (1985): 5.

Sceptical Chymist. "New Elements." *Chemical News* 40 (1879): 133.  
<https://hdl.handle.net/2027/wu.89100444694?urlappend=%3Bseq=143>.

Scerri, Eric. "The Periodic Table: The Ultimate Paper Tool in Chemistry." In *Tools and Modes of Representation in the Laboratory Sciences*, edited by U. Klein, 163-177. Dordrecht: Kluwer Academic Publishers, 2001.

Scerri, Eric R. *The Periodic Table: Its Story and Its Significance*. New York: Oxford University Press, 2007.

Scerri, Eric R. *The Periodic Table: A Very Short Introduction*. Oxford: Oxford University Press, 2011.

Scerri, Eric, and Guillermo Restrepo, ed. *Mendeleev to Oganesson: A Multidisciplinary Perspective on the Periodic Table*. New York: Oxford University Press, 2018.

Scerri, Eric R., and John Worrall. "Prediction and the Periodic Table." *Studies in History and Philosophy of Science* 32 (2001): 407-452. doi:10.1016/S0039-3681(01)00023-1.

Schlesinger, H. I. *General Chemistry*. New York: Longmans, Green and Co., 1925.

Schlesinger, H. I. *General Chemistry*. 2<sup>nd</sup> ed. New York: Longmans, Green and Co., 1931.

Schlesinger, H. I. *General Chemistry*. 3<sup>rd</sup> ed. New York: Longmans, Green and Co., 1937.

Schmidt, Curt. *Das periodische System der chemischen Elemente*. Leipzig: Johann Ambrosius Barth, 1917. [https://hdl.handle.net/2027/uc1.\\$b691329](https://hdl.handle.net/2027/uc1.$b691329).

Scott, E. L. "Newlands, John Alexander Reina." In *Complete Dictionary of Scientific Biography*, 10:37-39. Detroit: Charles Scribner's Sons, 2008.

Seaborg, Glenn T. "The Chemical and Radioactive Properties of the Elements." *Chemical & Engineering News* 23 (1945): 2190-2193. doi:10.1021/cen-v023n023.p2190.

“Seaborgium: Element 106 Named in Honor of Glenn T. Seaborg, LBL’s Associate Director at Large.” *LBL Research Review* 18, no.3 (1994): 8.  
<http://www2.lbl.gov/Science-Articles/Research-Review/Magazine/1994/seaborgium-mag.html>.

Sears, Geo. W. *Essentials of General Chemistry: An Introductory College Course*. Scranton: International Textbook Company, 1939.

Sears, Geo. W. “A New Form of Periodic Table as a Practical Means of Correlating the Facts of Chemistry.” *Journal of Chemical Education* 1 (1924): 173-177.  
doi:10.1021/ed001p173.

Senter, George. *A Text-Book of Inorganic Chemistry*. London: Methuen & Co. Ltd., 1911. <https://hdl.handle.net/2027/nyp.33433090731435>.

Senter, George. *A Text-Book of Inorganic Chemistry*. 5<sup>th</sup> ed. London: Methuen & Co. Ltd., 1919. [https://hdl.handle.net/2027/uc1.\\$b277864](https://hdl.handle.net/2027/uc1.$b277864).

Serres, Michel, ed. *A History of Scientific Thought: Elements of a History of Science*. Oxford: Blackwell Reference, 1995.

Seubert, Karl. “Zur Geschichte des periodischen Systems.” *Zeitschrift für anorganische Chemie* 9 (1895): 334-338.  
<https://hdl.handle.net/2027/uc1.b3959055?urlappend=%3Bseq=344>.

Sharples, Stephen P. *Chemical Tables*. Cambridge, MA: Sever and Francis, 1866.  
<https://books.google.com/books?vid=HARVARD:32044091934026>.

Shepard, James Henry. *Elements of Inorganic Chemistry, Descriptive and Qualitative*. Boston: D. C. Heath & Co., 1886.  
<https://books.google.com/books?id=mP44AAAAMAAJ>.

Siegfried, Robert. “Lavoisier’s Table of Simple Substances: Its Origin and Interpretation.” *Ambix* 29 (1982): 29-48.

Smith, John Russell. “Persistence and Periodicity: A Study of Mendeleev’s Contribution to the Foundations of Chemistry.” PhD diss., Chelsea College, 1976.

Smithells, Arthur. “General Chemistry.” Review of *General Chemistry*, by H. G. Deming. *Chemistry and Industry* 43 (1924): 625.

Smithells, Arthur. “Presidential Address.” In *Report of the Seventy-Seventh Meeting of the British Association for the Advancement of Science*, 469-479. London: John Murray, 1908. <https://biodiversitylibrary.org/page/29717632>.

Soddy, Frederick. *The Chemistry of the Radio-Elements, Part II: The Radio-Elements and the Periodic Law*. London: Longmans, Green and Co., 1914.

Soddy, Frederick. "The Conception of the Chemical Element as Enlarged by the Study of Radioactive Change." *Journal of the Chemical Society, Transactions* 115 (1919): 1-26. doi:10.1039/CT9191500001.

Soddy, F. "The Evolution of the Elements." In *Report of the Seventy-Sixth Meeting of the British Association for the Advancement of Science*, 122-131. London: John Murray, 1907. <https://biodiversitylibrary.org/page/29741724>.

Soddy, Frederick. *The Interpretation of Radium: Being the Substance of Six Free Popular Experimental Lectures Delivered at the University of Glasgow, 1908*. London: John Murray, 1909.

Soddy, Frederick. *The Interpretation of the Atom*. New York: G. P. Putnam's Sons, 1932.

Soddy, Frederick. "Intra-atomic Charge." *Nature* 92 (1913): 399-400. doi:10.1038/092399c0.

Soddy, Frederick. "The Origin of Actinium." *Nature* 91 (1913): 634-635. doi:10.1038/091634a0.

Soddy, Frederick. "Radioactivity." *Annual Reports on the Progress of Chemistry* 1 (1904): 244-280. doi:10.1039/AR9040100244.

Soddy, Frederick. "Radioactivity." *Annual Reports on the Progress of Chemistry* 3 (1906): 333-365. doi:10.1039/AR9060300333.

Soddy, Frederick. "Radioactivity." *Annual Reports on the Progress of Chemistry* 6 (1909): 232-267. doi:10.1039/AR9090600232.

Soddy, Frederick. "Radioactivity." *Annual Reports on the Progress of Chemistry* 10 (1913): 262-288. doi:10.1039/AR9131000262.

Soddy, Fredk. *Radio-Activity: An Elementary Treatise, From the Standpoint of the Disintegration Theory*. New York: The D. Van Nostrand Company, 1904. [https://books.google.com/books?id=m\\_lIAAAIAAJ](https://books.google.com/books?id=m_lIAAAIAAJ).

Soddy, Frederick. "The Radio-Elements and the Periodic Law." *Chemical News* 107 (1913): 97-99. <https://hdl.handle.net/2027/mdp.39015073139282?urlappend=%3Bseq=103>.

Soddy, Frederick. "The Radio-Elements and the Periodic Law." In *Report of the Eighty-Third Meeting of the British Association for the Advancement of Science*, 445-447. London: John Murray, 1914. <https://biodiversitylibrary.org/page/30382318>.

Soddy, F. "The Recent Controversy on Radium." *Nature* 74 (1906): 516-518. doi:10.1038/074516c0.

Solov'ev, Yu. I. "D. I. Mendeleev and the English Chemists." *Journal of Chemical Education* 61 (1984): 1069-1071. doi:10.1021/ed061p1069.

"The Solvay Institute of Chemistry." *Nature* 109 (1922): 718-719. doi:10.1038/109718a0.

Spring, W. "On a Method of Illustrating the Periodic Law." *Chemical News* 56 (1887): 4. <https://hdl.handle.net/2027/njp.32101075379337?urlappend=%3Bseq=12>.

Spring, W. "Ueber eine Methode, das periodische Gesetz zu erläutern." *Berichte der Deutschen chemischen Gesellschaft zu Berlin* 19 (1886): 3092-3093. <https://gallica.bnf.fr/ark:/12148/bpt6k907075/f574.item>.

Stacey, Frank D. "Kelvin's Age of the Earth Paradox Revisited." *Journal of Geophysical Research* 105 (2000): 13155-13158. doi:10.1029/2000JB900028.

Stas, J.-S. "Recherches sur les rapports réciproques des poids atomiques." *Bulletin de l'Académie Royale des Sciences (Belgique)*, 2<sup>nd</sup> ser., 10 (1860): 208-336. <https://hdl.handle.net/2027/pst.000060106681?urlappend=%3Bseq=222>.

Stöckhardt, Julius Adolph. *The Principles of Chemistry*. Translated by C. H. Peirce. Cambridge: John Bartlett, 1850. <https://books.google.com/books?vid=HARVARD:32044091852301>.

Stokes, H. N. "The Revival of Inorganic Chemistry." *Science*, n.s., 9 (1899): 601-615. <http://www.jstor.org/stable/1626055>.

Stoney, G. Johnstone. "On the Law of Atomic Weights." *Philosophical Magazine*, 6<sup>th</sup> ser., 4 (1902): 411-416. <https://hdl.handle.net/2027/hvd.32044089572200?urlappend=%3Bseq=441>.

Stoney, G. Johnstone. "On the Logarithmic Law of Atomic Weights. [Abstract]." *Proceedings of the Royal Society of London* 44 (1888): 115-117. <http://www.jstor.org/stable/114700>.

Stranges, Anthony N. *Electrons and Valence: Development of the Theory, 1900-1925*. College Station: Texas A&M University Press, 1982.

Strutt, R. J. "Discussion on Radio-activity and the Internal Structure of the Earth." In *Report of the Seventy-Sixth Meeting of the British Association for the Advancement of Science*, 491-492. London: John Murray, 1907.  
<https://biodiversitylibrary.org/page/29742097>.

Swartz, Norman. "Laws of Nature." *The Internet Encyclopedia of Philosophy*.  
<http://www.iep.utm.edu/lawofnat/>.

T. "Fownes's Inorganic Chemistry." Review of *Fownes's Inorganic Chemistry*, edited by Henry Watts. *Nature* 16 (1877): 6. doi:10.1038/016006a0.

"Tables of Chemical Formulæ." Review of *Tables of Chemical Formulæ*, by William Odling. *British And Foreign Medico-Chirurgical Review* 35 (1865): 147.  
<https://hdl.handle.net/2027/mdp.39015024483805?urlappend=%3Bseq=759>.

Taylor, Georgette. "Marking Out a Disciplinary Common Ground: The Role of Chemical Pedagogy in Establishing the Doctrine of Affinity at the Heart of British Chemistry." *Annals of Science* 65 (2008): 465-486.  
doi:10.1080/00033790701754290.

Taylor, Georgette. "Variations on a Theme: Patterns of Congruence and Divergence Among 18<sup>th</sup> Century Chemical Affinity Theories." PhD diss., University College London, 2006.

Taylor, Wendell H. "J. A. R. Newlands: A Pioneer in Atomic Numbers." *Journal of Chemical Education* 26 (1949): 491-496. doi:10.1021/ed026p491.

Thackray, Arnold. *Atoms and Powers: An Essay on Newtonian Matter-Theory and the Development of Chemistry*. Cambridge, MA: Harvard University Press, 1970.

Thomsen, Julius. "On the Conjectural Group of Inactive Elements." *Chemical News* 77 (1898): 120-121.  
<https://hdl.handle.net/2027/njp.32101075379519?urlappend=%3Bseq=128>.

Thomsen, Julius. "Systematic Arrangement of the Chemical Elements." *Chemical News* 72 (1895): 89-91.  
<https://hdl.handle.net/2027/inu.30000088771047?urlappend=%3Bseq=427>.

Thomsen, Julius. "Systematische Gruppierung der chemischen Elemente." *Zeitschrift für Anorganische Chemie* 9 (1895): 190-193.  
<https://hdl.handle.net/2027/uc1.b3959055?urlappend=%3Bseq=200>.

Thomsen, J. "Über die mutmassliche Gruppe inaktiver Elemente." *Zeitschrift für anorganische Chemie* 9 (1895): 283-288.  
<https://hdl.handle.net/2027/uc1.b3959055?urlappend=%3Bseq=293>.

Thomson, J. J. "Cathode Rays." *Philosophical Magazine*, 5<sup>th</sup> ser., 44 (1897): 293-316. [https://hdl.handle.net/2027/uc1.\\$b785916?urlappend=%3Bseq=307](https://hdl.handle.net/2027/uc1.$b785916?urlappend=%3Bseq=307).

Thomson, J. J. "On the Structure of the Atom: An Investigation of the Stability and Periods of Oscillation of a Number of Corpuscles Arranged at Equal Intervals Around the Circumference of a Circle; With Application of the Results to the Theory of Atomic Structure." *Philosophical Magazine*, 6<sup>th</sup> ser., 7 (1904): 237-265. <https://books.google.com/books?vid=HARVARD:32044093608537>.

Thomson, Thomas. *A System of Chemistry*. Vol. 1. Edinburgh, 1802. <https://hdl.handle.net/2027/uc1.aa0001914969>.

Thorburn Burns, D. and H. Deelstra. "The Origins and Impact of the International Congresses of Applied Chemistry." *Microchimica Acta* 172 (2011): 277-283. doi:10.1007/s00604-010-0465-3.

Thorpe, T. E. "Bakerian Lecture for 1907. On the Atomic Weight of Radium." *Proceedings of the Royal Society* 80A (1908): 298-309. <http://www.jstor.org/stable/92934>.

Thorpe, T. Edward. "The Presidential Address." In *Report of the Eighty-Ninth Meeting of the British Association for the Advancement of Science*, 1-24. London: John Murray, 1922. <https://biodiversitylibrary.org/page/30497586>.

Tilling, Laura. "Early Experimental Graphs." *British Journal for the History of Science* 8 (1975): 193-213. <http://www.jstor.org/stable/4025556>.

Travers, Morris W. *A Life of Sir William Ramsay, K.C.B., F.R.S.* London: Edward Arnold (Publishers) Ltd., 1956.

Trenn, Thadeus J. *The Self-Splitting Atom: The History of the Rutherford-Soddy Collaboration*. London: Taylor and Francis, 1977.

Trifonov, D. N. *The Rare-Earth Elements*. New York: The MacMillan Company, 1963.

Turner, E. "On Atomic Weights." In *Report of the First and Second Meetings of the British Association for the Advancement of Science at York in 1831 and at Oxford in 1832*, 576. Second ed. London: John Murray, 1835. <https://books.google.com/books?id=S3pMAQAAMAAJ>.

Turner, Edward. "Experimental Researches on Atomic Weights." *Philosophical Transactions of the Royal Society of London* 123 (1833): 523-544. <http://www.jstor.org/stable/108005>.

Turner, Edward. "On Some Atomic Weights." *Philosophical Magazine*, 3<sup>rd</sup> ser., 1 (1832): 109-112. <https://books.google.com/books?id=JW8qAAAAYAAJ>.

Urbain, Georges. *Les Notions Fondamentales d'Éléments Chimique et d'Atome*. Paris: Gauthier-Villars et Cie., 1925.

Urbain, G. "Twenty-five Years of Research on the Yttrium Earths." *Chemical Reviews* 1 (1924): 143-185. doi:10.1021/cr60002a001.

Ure, Andrew. "An Attempt to Establish the First Principles of Chemistry By Experiment." Review of *An Attempt to Establish the First Principles of Chemistry By Experiment*, by Thomas Thomson. *Quarterly Journal of Science, Literature, and the Arts* 10 (1826): 113-141.

<https://hdl.handle.net/2027/hvd.32044106374762?urlappend=%3Bseq=131>.

V. "Hydrogen or Oxygen as Basis of Atomic Weights - Which?" *Western Druggist* 22 (1900): 414-416. <https://books.google.com/books?id=7tPnAAAAMAAJ>.

van den Broek, A. "The Number of Possible Elements and Mendeléeff's 'Cubic' Periodic System." *Nature* 87 (1911): 78. doi:10.1038/087078b0.

van den Broek, A. "Die Radioelemente, das periodische System und die Konstitution der Atome." *Physikalische Zeitschrift* 14 (1913): 32-41.

<https://hdl.handle.net/2027/mdp.39015021268936?urlappend=%3Bseq=68>.

Van Tiggelen, Brigitte, and Danielle Fauque. "The Formation of the International Association of Chemical Societies." *Chemical International* 34, no. 1 (2012): 8-11. doi:10.1515/ci.2012.34.1.8.

Van Spronsen, J. W. "One Hundred Years of the 'Law of Octaves': When the Italian Cannizzaro was Fighting for Atomic Weights in Karlsruhe, Newlands Fought for the Liberation of Italy." *Chymia* 11 (1966): 125-137.

<http://www.jstor.org/stable/27757263>.

Van Spronsen, J. W. *The Periodic System of Chemical Elements: A History of the First Hundred Years*. Amsterdam: Elsevier, 1969.

Venable, F. P. "The Atomic Weights and Their Natural Arrangement." *Journal of the Elisha Mitchell Scientific Society* 11 (1894): 67-85.

<https://hdl.handle.net/2027/inu.30000091968671?urlappend=%3Bseq=77>.

Venable, F. P. "The Definition of the Element." *Science*, n.s., 10 (1899): 274-282.

<http://www.jstor.org/stable/1626614>.

Venable, F. P. "A Modified Arrangement of the Elements Under the Natural Law." *Journal of the American Chemical Society* 17 (1895): 75-84.

doi:10.1021/ja02157a001.



Venable, F. P. "New Grouping of the Elements." *Chemical News* 72 (1895): 126. <https://hdl.handle.net/2027/inu.30000088771047?urlappend=%3Bseq=464>.

Venable, F. P. "Some Difficulties in the Presentation of the Periodic Law." *Science*, n.s., 4 (1896): 160-162. <http://www.jstor.org/stable/1622770>.

Venable, F. P., and Jas. Lewis Howe. *Inorganic Chemistry According to the Periodic Law*. Easton, PA: The Chemical Publishing Co., 1898. <https://books.google.com/books?id=OPkJAAAAIAAJ>.

Venable, F. P., and Jas. Lewis Howe. *Inorganic Chemistry According to the Periodic Law*. Easton, PA: The Chemical Publishing Co., 1898.

Venable, Francis P. *A Brief Account of Radio-activity*. Boston: D. C. Heath & Co., Publishers, 1917. <https://archive.org/details/ost-chemistry-briefaccountofra00venarich>.

Venable, Francis Preston. *The Development of the Periodic Law*. Easton, PA: The Chemical Publishing Co., 1896. <https://books.google.com/books?id=tF0vAQAAMAAJ>.

von Richter, Victor. *A Text-Book of Inorganic Chemistry*. 2<sup>nd</sup> American ed. from the 4<sup>th</sup> German ed. Translated by Edgar Fahs Smith. Philadelphia: P. Blakiston, Son & Co., 1885. <https://books.google.com/books?id=7Q45AAAAMAAJ>.

von Richter, V. *Uchebnik neorganicheskoi khimii po noveishim vozzreniyam*. Warsaw, 1874.

Walker, James. "On the Periodic Tabulation of the Elements." *Chemical News* 63 (1891): 251-253. <https://hdl.handle.net/2027/nyp.33433062748128?urlappend=%3Bseq=257>.

Wardlaw, W. "Dr. George Senter." *Nature* 149 (1942): 405-406. doi:10.1038/149405a0.

Wartire, John. *A Definition of Terms, and Tables of Specific Attraction; As Used in Courses of General Chemistry*. London: 1770?. Eighteenth Century Collections Online.

Wartire, John. *Tables of the Various Combinations and Specific Attraction of the Substances Employed in Chemistry. Being a Compendium of that Science: Intended Chiefly for the Use of those Gentlemen and Ladies Who Attend the Author's Lectures*. London: 1769. Eighteenth Century Collections Online.

Warner, Deborah Jean. "Commodities for the Classroom: Apparatus for Science and Education in Antebellum America." *Annals of Science* 45 (1988): 387-397.

- Watts, Henry. *Fownes' Manual of Chemistry: Theoretical and Practical*. 12<sup>th</sup> ed. London: J. & A. Churchill, 1877. <https://hdl.handle.net/2027/wu.89097708622>.
- Watts, Iain. "‘We Want No Authors’: William Nicholson and the Contested Role of the Scientific Journal in Britain, 1797-1813." *British Journal for the History of Science* 47 (2014): 397-419. doi:10.1017/S0007087413000964.
- Watts, W. Marshall. "On the Atomic Weight of Radium." *Philosophical Magazine*, 6<sup>th</sup> ser., 6 (1903): 64-66. <https://hdl.handle.net/2027/hvd.32044089572259?urlappend=%3Bseq=80>.
- Watts, W. Marshall. "On the Calculation of the Atomic Weight of Radium from Spectroscopic Data." *Philosophical Magazine*, 6<sup>th</sup> ser., 18 (1909): 411-413. <https://archive.org/details/londonedinburg6181909lond>.
- Wendt, Gustav. *Die Entwicklung der Elemente. Entwurf zu einer biogenetischen Grundlage für Chemie und Physik*. Berlin: Hirschwald, 1891. <https://books.google.com/books?id=ZKQtAQAAMAAJ>.
- Werner, A. "Beitrag zum Ausbau des periodischen Systems." *Berichte der deutschen chemischen Gesellschaft* 38 (1905): 914-921. <https://hdl.handle.net/2027/iau.31858002459455?urlappend=%3Bseq=922>.
- Werner, A. *Neuere Anschauungen auf dem Gebeite der anorganischen Chemie*. Braunschweig: F. Vieweg und Sohn, 1905.
- Werner, A. *New Ideas on Inorganic Chemistry*. From the 2<sup>nd</sup> German ed. Translated by Edgar Percy Hedley. London: Longmans, Green, and Co., 1911. <https://books.google.com/books?id=STe4AAAAIAAJ>.
- Wilde, Henry. *On the Origin of Elementary Substances, and on Some New Relations of Their Atomic Weights*. London: Kegan Paul, Trench, Trübner & Co., 1892). <https://books.google.com/books?id=1fRaAAAAQAAJ>.
- Wiley, H. W. "The Fourth International Congress of Applied Chemistry." *Journal of the American Chemical Society* 23 (1901): 178-197. doi:10.1021/ja02029a010.
- Wisniak, Jaime. "Thomas Carnelley." *Educación Química*, 23 (2012): 465-473.
- Wood, Jesse Hermon, and Charles William Keenan. *General College Chemistry*. New York: Harper & Brothers, Publishers, 1957.
- Woodiwiss, Geo. "Some of the Non-metallic Elements in Connection with Valency and Specific Gravity." *Chemical News* 97 (1908): 265. <https://hdl.handle.net/2027/njp.32101075379873?urlappend=%3Bseq=275>.

Woods, Gordon. "British Reception of Periodicity." In *Early Responses to the Periodic System*, edited by Masanori Kaji, Helge Kragh, and Gábor Palló, 75-102. New York: Oxford University Press, 2015.

Wurtz, Adolph. "Account of the Sessions of the International Congress of Chemists in Karlsruhe, on 3, 4, and 5 September 1860." In *The Question of the Atom: From the Karlsruhe Congress to the First Solvay Conference, 1860-1911*, edited by Mary Jo Nye, 5-28. Los Angeles: Tomash Publishers, 1984.

Wurzer, Hofrath. "Auszug eines Briefes von Hofrath Wurzer, Prof. der Chemie zu Marzburg." *Annalen der Physik* 56 (1817): 331-334.  
<https://hdl.handle.net/2027/uc1.b4433520?urlappend=%3Bseq=349>.

"York meeting of the British Association for the Advancement of Science." *Electrical World* 48 (1906): 471.  
<https://hdl.handle.net/2027/uc1.c2662337?urlappend=%3Bseq=499>.

Zapffe, Carl A. "Gustavus Hinrichs, Precursor of Mendeleev." *Isis* 60 (1969): 461-476. <http://www.jstor.org/stable/229106>.

Zumdahl, Steven S. *Chemistry*. 4<sup>th</sup> ed. Boston: Houghton Mifflin Company, 1997.

### **Web Sites and Blogs**

Ball, Philip. "New Chemistry Revives Elementary Question." 12 January 2016. *Nature*. <http://www.nature.com/news/new-chemistry-revives-elementary-question-1.19145>.

Ball, Philip. "The Place of the Periodic Table." *homunculus*. 12 January 2016. <http://philipball.blogspot.com/2016/01/the-place-of-periodic-table.html>.

Banks, Michael. "Visualizing the Periodic Table of the Elements." *Physics World Blog*. 7 October 2009. <http://blog.physicsworld.com/2009/10/07/visualizing-the-periodic-table/>.

Béguyer de Chancourtois, Alexandre-Émile. "Vis tellurique." *Bibliothèque patrimoniale numérique de l'École nationale supérieure des mines de Paris (Mines ParisTech)*. [https://patrimoine.mines-paristech.fr/document/Vis\\_tellurique](https://patrimoine.mines-paristech.fr/document/Vis_tellurique).

Diaz, Jesus. "The Circular Periodic Table of Elements." *Gizmodo*, 9 October 2009, <http://gizmodo.com/5378105/the-circular-periodic-table-of-elements>.

"Does a Circular Periodic Table Make Sense?" *Seeker*. 6 October 2009. <http://www.seeker.com/does-a-circular-periodic-table-make-sense-1764727884.html>.

Dufour, Fernando. "The ElementTree Periodic Table." <http://www.elementree.ca/>.

"Encyclopédie de l'Agora | Tableau périodique."  
[http://agora.qc.ca/Dossiers/Tableau\\_periodique](http://agora.qc.ca/Dossiers/Tableau_periodique).

International Commission on Zoological Nomenclature. "About the ICZN."  
<http://iczn.org/content/about-iczn>.

International Union of Pure and Applied Chemistry. *Compendium of Chemical Terminology*. XML on-line corrected version of the 2<sup>nd</sup> ed., 1997. <http://goldbook.iupac.org/>.

Leach, Mark R. "The Internet Database of Periodic Tables." [http://www.meta-synthesis.com/webbook/35\\_pt/pt\\_database.php](http://www.meta-synthesis.com/webbook/35_pt/pt_database.php).

"A New Graphical Representation of the Periodic Table." X<sub>b</sub>, 6 October 2009.  
<https://www.technologyreview.com/s/415613/a-new-graphical-representation-of-the-periodic-table/>.

Nobel Foundation. "The Nobel Prize in Chemistry 1904."  
[http://www.nobelprize.org/nobel\\_prizes/chemistry/laureates/1904/](http://www.nobelprize.org/nobel_prizes/chemistry/laureates/1904/).

Nobel Foundation. "The Nobel Prize in Physics 1904."  
[http://www.nobelprize.org/nobel\\_prizes/physics/laureates/1904/](http://www.nobelprize.org/nobel_prizes/physics/laureates/1904/).

"Periodic Table of Videos." <http://www.periodicvideos.com/>.

Sargent-Welch. "Periodic Chart of the Atoms." <http://sargentwelch.com/periodic-chart-of-the-atoms/p/IG0039635/>.

Science & Society Picture Library. "White, Ron – Telluric screw of de Chancourtois, c 1862." <http://www.ssplprints.com/image/84737/white-ron-telluric-screw-of-de-chancourtois-c-1862>.