



ASEE EDGD Midyear Conference

70th Midyear Technical Conference: Graphical Expressions of Engineering Design

---

## Visualizing Electric Circuits: The Role of Spatial Visualization Skills in Electrical Engineering

Gavin Duffy

*Dublin Institute of Technology, [gavin.duffy@dit.ie](mailto:gavin.duffy@dit.ie)*

Sheryl Sorby

*The Ohio State University*

Brian Bowe

*Dublin Institute of Technology, [brian.bowe@dit.ie](mailto:brian.bowe@dit.ie)*

Follow this and additional works at: <https://commons.erau.edu/asee-edgd>

---

Duffy, Gavin; Sorby, Sheryl; and Bowe, Brian, "Visualizing Electric Circuits: The Role of Spatial Visualization Skills in Electrical Engineering" (2016). *ASEE EDGD Midyear Conference*. 16.  
<https://commons.erau.edu/asee-edgd/conference70/papers-2016/16>

This Event is brought to you for free and open access by the ASEE EDGD Annual Conference at Scholarly Commons. It has been accepted for inclusion in ASEE EDGD Midyear Conference by an authorized administrator of Scholarly Commons. For more information, please contact [commons@erau.edu](mailto:commons@erau.edu).

# Visualizing Electric Circuits: The Role of Spatial Visualization Skills in Electrical Engineering

*G. Duffy*

*School of Electrical and Electronic Engineering  
Dublin Institute of Technology*

*Sheryl Sorby*

*Department of Engineering Education  
Ohio State University*

*B. Bowe*

*College of Engineering and Built Environment  
Dublin Institute of Technology*

## **Abstract**

*A significant and sizeable correlation is established between engineering students' scores on a spatial visualization test and their scores on an electric circuits concept test with about 25 % of the variation shared between the two tests. Visualization appears to play a very important role in the analysis of electric circuits which requires the mental transformation of pictorial representations of circuits to formal circuit diagrams.*

## **Introduction**

Competence in the understanding and analysis of electrical circuits is a fundamental requirement for electrical engineering students. Circuits classes taken in the first year of the curriculum typically cover topics related to simple direct current (D.C.) electrical circuits and these learning outcomes are fundamental to the rest of the curriculum. However, tests of conceptual understanding of simple D.C. circuits have shown how many students have great difficulty in grasping these concepts as revealed in the low scores achieved on these tests. For example, for university students in the US the average score on the DIRECT electric circuits test was 52 % (Engelhardt & Beichner, 2004); in Ireland, for a group of common 1<sup>st</sup> year engineering students, the average score on the same test after the circuits classes had been completed was 47 % (compared to 29 % prior to instruction) (Duffy & O'Dwyer, 2015). Clearly, at a conceptual level, developing an understanding of simple DC electric circuits is very challenging.

At a general level, spatial skills have been shown to be a very important indicator of success in science, technology, engineering and mathematics (STEM) education (Wai, Lubinski, & Benbow, 2009). However, relatively little is known about which particular aspects of engineering curricula are most influenced by spatial thinking. Correlations between spatial tests and tests of conceptual understanding in physics of a moderate size have been measured (Kozhevnikov & Thornton, 2006; Mac Raighne et al., 2015) with this correlation attributed to visualization skills (Kozhevnikov, Motes, & Hegarty, 2007). Some studies in maths education have also revealed

moderate to large correlation sizes (e.g. Casey, Nuttall, & Pezaris, 2001). Perhaps spatial visualization also has an important role to play in the understanding of electric circuits given the heavy use of diagram representation of circuits in the subject. The purpose of this study was to examine the role spatial visualization has to play in a specific aspect the electrical engineering curriculum, the understanding of simple DC electric circuits.

### Procedure

Two spatial skills tests, the Mental Rotations Test A (MRT-A) (Peters et al., 1995) and the Mental Cutting Test (MCT) (CEEB, 1939), and an electric circuits concept test, DIRECT 1.1 (Engelhardt & Beichner, 2004), were administered, in that order, during a 1 hour class period to those in attendance from a 3rd year Bachelor in Electrical Engineering class, Dublin Institute of Technology. The tests were administered as recommended by their authors with one exception: since the majority of the class had finished the MCT after 13 mins, it was concluded after 16 mins rather than 20 mins due to time pressure. The MRT was scored by giving 1 point for correctly identifying both matching figures; identifying one only was scored as 0. Both the MCT and the DIRECT tests have only one correct answer per question. While the DIRECT test does not have separate sections, instructions from the authors are to group different questions together at the analysis phase into 4 groups – A, physical aspects of DC electric circuits, B, energy, C, current and D, voltage. The DIRECT test scores for each group were computed along with the overall score. Correlations were computed using the Pearson correlation coefficient.

### Results and Analysis

Descriptive statistics are provided in Table 1 and the correlation matrix for these data is provided in Table 2. The sample size was  $n = 27$ , 6 female and 21 male participants.

Test	Mean	S. D.	Test	Mean	S. D.
MRT-A 1 (12) <sup>1</sup>	5.00	3.000	DIRECT A (12) <sup>2</sup>	6.93	2.541
MRT-A 2 (12)	5.63	2.989	DIRECT B (4)	1.07	.997
MRT (24)	10.63	5.583	DIRECT C (5)	1.63	.967
MCT (25)	10.41	5.337	DIRECT D (9)	3.26	1.559
			DIRECT (29)	12.33	3.843
			DIRECT (100 %)	42.48	13.320

<sup>1</sup> Number of questions on the test is shown in brackets

<sup>2</sup> Question 27 is counted twice in this group

**Table 1. Descriptive statistics for the tests (no. of questions in brackets)**

	MRT-A	MCT	DIRECT29	DIRECT A	DIRECT B	DIRECT C	DIRECT D
MRT-A		.643**	.264	.505**	-.112	.138	-.081
MCT			.492**	.527**	.298	.001	.320
DIRECT29				.806**	.666**	.200	.807**
DIRECT A					.367	-.090	.442*
DIRECT B						-.130	.630**
DIRECT C							.015

\*\* . Correlation is significant at the 0.01 level (2-tailed).

\* . Correlation is significant at the 0.05 level (2-tailed).

**Table 2. Correlation matrix for all test results from this study (Pearson correlation)**

There is no significant correlation between the MRT-A and the DIRECT test overall scores. However, there is a moderate ( $r = .505$ ) and highly significant ( $p < .01$ ) correlation between the Group A questions on DIRECT and MRT-A. The correlation coefficient between the MCT and the DIRECT test is moderate ( $r = 0.492$ ) and highly significant ( $p < .01$ ). This correlation is almost entirely related to the questions in Group A, ‘physical aspects of circuits’ ( $r = .527, p < .01, r^2 = 0.28$ ). Approximately 25 % of the variation in the answers to this group of questions is shared with the MCT. The apparently large amount of scatter in the plot (not included due to length restriction) prompted the calculation of confidence intervals for the correlation coefficient. The confidence intervals, derived from bootstrapping, for the correlation between the MCT and DIRECT Group A were found to be .201 (lower) and .765 (upper) indicating the persistence of a weak to moderate correlation despite a more robust statistical analysis. The very high significance level of the correlation along with positive values for lower and upper confidence intervals indicates the correlation has not emerged by chance and is very likely to be found in the population (of electrical engineering students) or in another sample of these students.

## Discussion

Any correlation between spatial ability and DIRECT test scores is due to the Group A questions - ‘physical aspects of circuits’. Correlations of similar magnitudes and significance levels were found in another study with a common first year engineering class in DIT in which the MCT and the Purdue Spatial Visualization Test of Rotations (PSVT:R)(Bodner & Guay, 1997) was used (Duffy & O’Dwyer, 2015);. The physical group tests the ability to identify and explain a short circuit, a complete circuit and to interpret pictures and diagrams of a variety of circuits among other things (see Engelhardt & Beichner, 2004 for more detail).

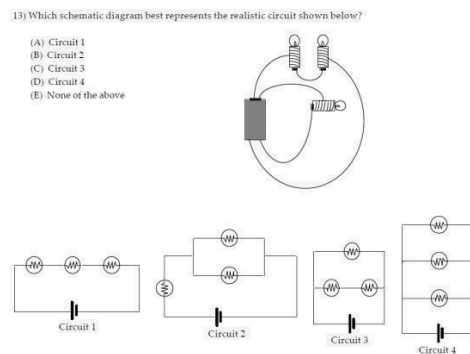

**Figure 1. Question 13 on the DIRECT test (Engelhardt & Beichner, 2004)**

Question 13, shown in Figure 1 and included the physical group, illustrates a requirement to mentally transform a circuit from an informal, toy sketch into a formal circuit diagram. Either the visual representation in the informal sketch must be held in working memory and transformed into the correct formal diagram or each of the formal diagrams must be cross checked against aspects

of the toy sketch to see if they match. In each case, the ability to visualize and mentally transform the circuit is vitally important as failure at this step implies the subsequent analysis of the circuit will be flawed. For example, if several resistors are involved and the task is to calculate the total resistance, an incorrect diagram at this point will result in the wrong answer. A similar process can be found in a Thévenin analysis of a circuit as this involves the conversion of the circuit from one shape to another. For example, consider transformation involved in converting the Wheatstone bridge on the left of Figure 2 to a Thévenin equivalent circuit on the right. A correct calculation of the Thévenin resistance can only follow if the graphical transformation step is successful. Such operations are fundamental to electrical engineering education.

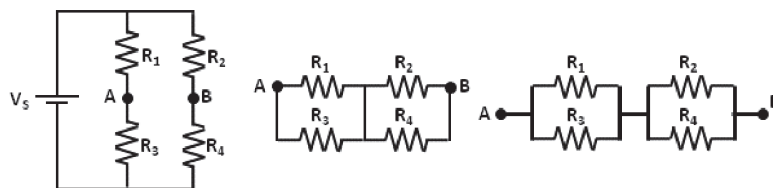

Figure 2. Thévenin transformation of the Wheatstone bridge circuit

## Conclusions

Highly significant correlations of a moderate to large size have been observed between scores on spatial tests and an electrical concept test for two samples of engineering students. This correlation is almost entirely due to the scores on questions related to physical aspects of circuits. It appears that the ability to mentally transform circuit diagrams shares much in common with the ability to answer questions on tests of spatial visualization and mental transformation. It is planned to repeat these tests with different samples in several locations.

## References

- Bodner, G. M., & Guay, R. B. (1997). The Purdue visualization of rotations test. *The Chemical Educator*, 2(4), 1-17.
- Casey, M. B., Nuttall, R. L., & Pezaris, E. (2001). Spatial-mechanical reasoning skills versus mathematics self-confidence as mediators of gender differences on mathematics subtests using cross-national gender-based items. *Journal for Research in Mathematics Education*, 28-57.
- CEEB. (1939). CEEB Special Aptitude Test in Spatial Relations. New York: College Entrance Examination Board.
- Duffy, G., & O'Dwyer, A. (2015). *Measurement of first year engineering students cognitive activities using a spatial skills test and an electrical concepts test: implications for curriculum design*. Paper presented at the Research in Engineering Education Symposium.
- Engelhardt, P. V., & Beichner, R. J. (2004). Students' understanding of direct current resistive electrical circuits. *American Journal of Physics*, 72(1), 98-115.
- Kozhevnikov, M., Motes, M. A., & Hegarty, M. (2007). Spatial Visualization in Physics Problem Solving. [Article]. *Cognitive Science*, 31(4), 549-579.
- Kozhevnikov, M., & Thornton, R. (2006). Real-Time Data Display, Spatial Visualization Ability, and Learning Force and Motion Concepts. [Article]. *Journal of Science Education & Technology*, 15(1), 111-132.

- Mac Raighne, A., Behan, A., Duffy, G., Farrell, S., Harding, R., Howard, R., et al. (2015). *Examining the relationship between physics students' spatial skills and conceptual understanding of Newtonian mechanics*. Paper presented at the Research in Engineering Education Symposium.
- Peters, M., Laeng, B., Latham, K., Jackson, M., Zaiyouna, R., & Richardson, C. (1995). A redrawn Vandenberg and Kuse Mental Rotations Test: Different versions and factors that affect performance. *Brain and Cognition*, 28(1), 39-58.
- Wai, J., Lubinski, D., & Benbow, C. P. (2009). Spatial ability for STEM domains: Aligning over 50 years of cumulative psychological knowledge solidifies its importance. *Journal of Educational Psychology*, 101(4), 817.