

South Dakota State University
**Open PRAIRIE: Open Public Research Access Institutional
Repository and Information Exchange**

Electronic Theses and Dissertations

2018

Low Power Wide Area Networks (LPWAN): Technology Review And Experimental Study on Mobility Effect

Dhaval Patel
South Dakota State University

Follow this and additional works at: <https://openprairie.sdstate.edu/etd>

 Part of the [Digital Communications and Networking Commons](#), [Power and Energy Commons](#),
and the [Systems and Communications Commons](#)

Recommended Citation

Patel, Dhaval, "Low Power Wide Area Networks (LPWAN): Technology Review And Experimental Study on Mobility Effect" (2018).
Electronic Theses and Dissertations. 2667.
<https://openprairie.sdstate.edu/etd/2667>

This Thesis - Open Access is brought to you for free and open access by Open PRAIRIE: Open Public Research Access Institutional Repository and Information Exchange. It has been accepted for inclusion in Electronic Theses and Dissertations by an authorized administrator of Open PRAIRIE: Open Public Research Access Institutional Repository and Information Exchange. For more information, please contact michael.biondo@sdstate.edu.

LOW POWER WIDE AREA NETWORKS (LPWAN): TECHNOLOGY REVIEW AND
EXPERIMENTAL STUDY ON MOBILITY EFFECT

BY

DHAVAL PATEL

A thesis submitted in partial fulfillment of the requirements for the

Master of Science

Major in Computer Science

South Dakota State University

2018

LOW POWER WIDE AREA NETWORKS (LPWAN): TECHNOLOGY REVIEW AND
EXPERIMENTAL STUDY ON MOBILITY EFFECT

DHAVAL PATEL

This thesis is approved as a creditable and independent investigation by a candidate for the Master of Science degree in Computer Science and is acceptable for meeting the thesis requirements for this degree. Acceptance of this thesis does not imply that the conclusions reached by the candidates are necessarily the conclusions of the major department.

Myounggyu Won, Ph.D.
Thesis Advisor

Date

George Hamer, Ph.D.
Acting Head, Department of EECS

Date

Dean, Graduate School

Date

ACKNOWLEDGEMENTS

I would like to extend my thank you to my thesis advisor Dr. Myounggyu Won for immense support and guidance not only for this research but for the entire journey towards my Master degree at South Dakota State University. Dr. Won always allowed me to work at my own pace and guided me in the right direction. His subject knowledge and research methodology is what helped me complete this research. Further I would like to thank Dr. Shin and Dr. Ali Salehnia who are on the panel committee for their valuable insights and feedback on this research. I would like to extend my gratitude to my wife who showed immense support and patience while I was busy working on this research. She stood by me through all those stressful times when the research progress slowed down and always motivated me to be optimistic. Finally, I would like to thank my parents who gave me an opportunity to study masters at South Dakota State University. All my achievements are a combined effort of the individuals I mentioned above and I cannot thank you enough for your support.

CONTENTS

LIST OF TABLES AND FIGURES	viii
ABBREVIATIONS	ix
ABSTRACT	xi
1 Introduction	1
1.1 Motivation	1
1.2 State of the Art	2
1.3 Research Objectives	3
1.4 Proposed Approach	4
1.5 Organization of the Work	4
2 Low Power Wide Area Network (LPWAN): Review	6
2.1 Overview of Internet of Things	6
2.2 Overview of LPWAN	7
2.3 Modulation Techniques for LPWAN	7
2.3.1 Modulation Fundamentals	7
2.3.2 LPWAN Modulation	12
2.4 LPWAN Standards	14
2.4.1 Ingenu-RPMA	14
2.4.2 Dash7	15
2.4.3 Weightless-SIG	17
2.4.4 IEEE 802.11ah	18
2.4.5 Sigfox	20
2.4.6 NB-IoT	21
2.5 Overview of LoRaWAN	25
2.5.1 LoRa	25

2.5.2	LoRa Alliance	25
2.5.3	LoRaWAN	27
2.5.4	LoRaWAN Network Protocol	28
2.5.5	LoRaWAN Module Classes	29
2.5.6	LoRaWAN Security	32
2.5.7	End-Device Joining	33
3	Mobility in LPWAN	36
4	System Implementation	41
4.1	System Architecture	41
4.2	LoRa Module	42
4.2.1	Message Flow in Symphony Link	45
4.2.2	Uplink Message	46
4.2.3	Code implementation for Uplink Message	47
4.3	LoRa Gateway	57
4.3.1	Gateway Configuration	58
4.4	Conductor-Data Platform	59
4.5	Prelude	60
4.6	Lessons Learned	60
5	Experimental Setup	62
6	Experimental Results	64
6.1	Impact of Packet Size - Indoor Mobile Environment	65
6.2	Impact of Distance - Indoor Mobile Environment	66
6.3	Impact of Packet Size - Outdoor Mobile Environment	68
6.4	Impact of Distance - Outdoor Mobile Environment	71
7	Lessons Learned	75

7.1	Agriculture livestock tracking	75
7.2	Healthcare Monitoring	76
7.3	LPWAN for UAVs	78
7.4	General guidelines	79
8	Conclusions and Future Work	80
8.1	Conclusion	80
8.2	Future Work	81
	REFERENCES	82

LIST OF TABLES AND FIGURES

2	Frequency modulation.	9
3	Amplitude modulation.	10
4	Digital modulation.	11
5	Constellation graph for QPSK.	12
6	Wireless technologies comparison [62].	14
7	LPWAN standard comparison [29].	24
8	LoRa sponsor members [28].	26
9	LoRaWAN network structure.	28
10	LoRaWAN network layers.	30
11	LoRaWAN class A device.	31
12	LoRaWAN class B device.	31
13	LoRaWAN class C device.	32
14	LoRaWAN security.	33
15	Experimental setup: (a) end device subjected to angular velocity and (b) heat map of car driven on motorway across the gateway [47].	36
16	System architecture.	41
17	LL-RXR-27 evaluation board.	43
18	Symphony link network architecture.	44
19	Message flow between host and end node.	45
20	LL-BST-8 gateway.	57
21	Gateway configuration.	58
22	Prelude symphony link application.	60
23	Experimental setup.	63
24	Code result.	64
25	Effect of mobility with varying packet sizes (indoor).	65
26	Effect of mobility with distance of 0.1 mile (indoor).	67

27	Effect of mobility with distance of 0.3 mile (indoor).	67
28	Effect of mobility on packet loss rates (indoor).	68
29	Effect of mobility on packet sizes (outdoor).	69
30	CDF for end-to-end delay for variable vehicle speed with 80-byte packet at 0.1 mile (outdoor).	70
31	Effect of mobility on packet loss rates (outdoor).	71
32	Effect of mobility with varying distance (outdoor).	72
33	CDF for end-to-end delay for variable vehicle speed with 80 byte packet at 0.3mile (outdoor).	73
34	Effect of mobility on packet loss rates (outdoor).	74

ABBREVIATIONS

16-QAM	16-Quadrature Amplitude Modulation
ABP	Activation By Personalization
ADR	Adaptive Data Rate
AES	Advanced Encryption Standard
AID	Association Identification
AP	Access Point
AppSKey	Application Session Key
ASK	Amplitude Shift Keying
CDMA	Code Division Multiple Access
CSS	Chirp Spread Spectrum
D7AP	DASH7 Alliance Protocol
DBPSK	Differential Binary Phase Shift Keying
DevAddr	Device Address
DSSS	Direct Sequence Spread Spectrum
DTIM	Delivery Traffic Identification Map
ESTI	European Telecommunications Standards Institute
FDMA	Frequency Division Multiple Access
FSK	Frequency Shift Keying
GMSK	Gaussian Minimum Shift Keying
GPS	Global Positioning System
IoT	Internet of Things
ISM	Industrial Scientific Medical
LoRa	Long Range
LoRaWAN	Long Range Wide Area Network
LPWAN	Low Power Wide Area Network
LTE	Long Term Evolution

M2M	Machine to Machine
MAC	Medium Access Control
MTU	Maximum Transmission Unit
NwkSKey	Network Session Key
OFDMA	Orthogonal Frequency Division Multiple Access
OTAA	Over the Air Activation
PRB	Physical Resource Block
PSK	Phase Shift Keying
QAM	Quadrature Amplitude Modulation
QoS	Quality of Service
QPSK	Quadrature Phase Shift Keying
RAW	Restricted Access Window
RPMA	Random Phase Multiple Access
STA	Associated Station
TIM	Traffic Identification Map
TWT	Target Wake Time
UART	Universal Asynchronous Receiver Transmitter
UAV	Unmanned Aerial Vehicle
UHF	Ultra High Frequency
UNB	Ultra Narrow Band

ABSTRACT

LOW POWER WIDE AREA NETWORKS (LPWAN): TECHNOLOGY REVIEW AND
EXPERIMENTAL STUDY ON MOBILITY EFFECT

DHAVAL PATEL

2018

In the past decade, we have witnessed explosive growth in the number of low-power embedded and Internet-connected devices, reinforcing the new paradigm, Internet of Things (IoT). IoT devices like smartphones, home security systems, smart electric meters, garage parking indicators, *etc.*, have penetrated deeply into our daily lives. These IoT devices are increasingly attached and operated in mobile objects like unmanned vehicles, trains, airplanes, *etc.*

The low power wide area network (LPWAN), due to its long-range, low-power and low-cost communication capability, is actively considered by academia and industry as the future wireless communication standard for IoT. However, despite the increasing popularity of mobile IoT, little is known about the suitability of LPWAN for those mobile IoT applications in which nodes have varying degrees of mobility. To fill this knowledge gap, in this thesis:

1. We present a thorough review on LPWAN technology focusing on the mobility effect.
2. We conduct an experimental study to evaluate, analyze, and characterize LPWAN in both indoor and outdoor mobile environments.

Our experimental results indicate that the performance of LPWAN is surprisingly susceptible to mobility, even to minor human mobility, and the effect of mobility significantly escalates as the distance to the gateway increases. These results call for development of new mobility-aware LPWAN protocols to support mobile IoT.

1 INTRODUCTION

Explosive growth in the number of Internet-connected things in the past decade has driven the emergence of new wireless communication technology called LPWAN. LPWAN is increasingly gaining popularity from industrial and research communities because of its low power, long-range, and low-cost communication characteristics. More specifically, it provides long-range communication of up to 10-15 km in rural areas and 2-5km in urban areas [11], and it is highly energy-efficient and inexpensive-the industry is targeting 10+ year battery life [30] with a radio chipset cost of less than \$2 and the operating cost of \$1 per device per year [41].

1.1 MOTIVATION

The promising prospect of LPWAN has prompted recent experimental studies on the performance of LPWAN [46][4][48]. However, IoT devices are getting more mobile as manifested by recent IoT applications (*e.g.*, healthcare [19], automotive sensor networks [15], industrial applications [24], and transportation [9][70][71]). IoT devices are increasingly attached and operated in mobile objects like unmanned aerial vehicles, trains, airplanes, *etc.* Furthermore, flexible and wearable sensors are more widely used [42][56][73]; it is forecasted that there will be more than three billion wearable sensors by 2050 [65].

Many researchers have already stressed the significance of mobile IoT. Stankovic remarked the robustness issue in a mobile environment, *i.e.*, the system stability is impacted by mobility [60]. Chen *et al.* reported that the IoT services in China are becoming mobile, decentralized, and complex [12]. Mobile IoT for smart cars has been considered [75]. Skorin-Kapov *et al.* approached mobile IoT from the perspective of mobile crowdsensing, *i.e.*, collecting data from a large number of mobile sensors [58]. Mozaffari *et al.* extended the limitation of static IoT by integrating the mobility of UAVs

with IoTs [36]. Rosario *et al.* investigated a routing protocol for mobile IoTs [52]. A vehicular network based on vehicle to vehicle communication (V2V) among a large number of cars itself can be seen as a large-scale mobile IoT [69][72]. However, despite the increasing significance and popularity of mobile IoT, little is known about whether LPWAN is a suitable communication standard for those mobile IoT applications.

1.2 STATE OF THE ART

Although many research has been done to study the effects of network parameters on the performance of LPWAN, few of them have attempted to study the effect of mobility on LPWAN. In [46], Petajajarvi *et al.* have conducted a study on the performance of LPWAN in an indoor environment. They conducted experiments by having LPWAN end nodes operate in different settings concentrating on the physical layer properties, *e.g.*, network bandwidth, spreading factor, and transmission power. Petric *et al.* have proposed a technology called LoRa (Long Range) FABIAN and conducted experiments by varying network parameters to study the quality of service (QoS) of the proposed technology [48]. The experiments conducted in [44] are focused on testing the LPWAN performance with varying distance between the end node and the gateway. The experiments were conducted in an urban city of Incheon in South Korea. The authors reveal that unique design methods must be followed in deploying LPWAN for different types of applications. The results published in [34] demonstrated the effect of using different modulation coding schemes in the real world LPWAN networks. In [26], Laveyne *et al.* have demonstrated the feasibility of using LPWAN network for Smart Metering device application. The authors performed experiments with varying data rates, and packet sizes and conclude with revealing their suitability for being used in applications which do not need high data rates and are able to achieve the needed performance even at a higher latency. Similar to the network settings in [46], Cattani *et al.* performed experiments by varying the physical layer settings of LPWAN to measure the LPWAN performance in terms of achievable bitrate [10]. The

research demonstrates that data rates are considerably affected by higher temperatures. Augustin *et al.* provided a comprehensive evaluation of LPWAN performance in terms of maximum throughput and total capacity of the network [6]. The experimental results in [40] showed the comparison between two important LPWAN technologies, LoRaWAN and Sigfox. The findings suggest that Sigfox is able to provide a range of 25km while using 14dBm with the signal to noise ratio always exceeding 20dB while a LoRa base station can offer a coverage area of 1380 square kilometers when the base station is set at the height of 470m above the sea level. Iova *et al.* have taken a unique approach to study the behavior of LPWAN in mountain areas and dense vegetation to study the effect of vegetation and antenna height on communication characteristics [22]. Wang *et al.* performed a comparative analysis between two LPWAN technologies LoRa and NB-IoT to find which is best suited for designing LPWAN network in power grid [63].

Although numerous experimental studies have been done under various application domains, to the best of our knowledge, there are few work that investigated the LPWAN performance in mobile environments despite the gaining popularity of mobile IoT. In this thesis, we perform the first experimental study on the mobility effect on LPWAN.

1.3 RESEARCH OBJECTIVES

The objectives of this research are three folds.

- Perform a thorough review on the emerging LPWAN technology concentrating on the effect of mobility.
- Perform real world experiments to analyze the mobility effect on the LPWAN technology.
- Provide guidelines for deploying LPWAN in mobile environments.

1.4 PROPOSED APPROACH

In this thesis, we perform a comprehensive real-world experimental study to evaluate, analyze and characterize the performance of LPWAN in both indoor and outdoor environments with varying degrees of mobility. Consequently, we report three major findings on the performance of LPWAN (in terms of end-to-end delay and packet loss rates):

- The performance of LPWAN is impacted even by a small degree of mobility (i.e. human mobility)
- The effect of mobility is greater in an indoor environment.
- The longer distance to the gateway further escalates the impact of mobility.

These results suggest that new mobility aware LPWAN protocols need to be developed.

The contributions of this research are summarized as follows.

- We present a through review on LPWAN focusing on mobility effect.
- We provide the first real-world experimental results that characterize the performance of LPWAN for mobile IoT applications.
- We consider the effect of mobility in both indoor and outdoor mobile environments.
- We provide a multidimensional analysis on the performance of LPWAN by varying degrees of mobility along with adjustment of network parameters such as the packet size and the distance to the gateway.

1.5 ORGANIZATION OF THE WORK

This thesis is organized into eight chapters. After presenting Introduction in Chapter 1, in Chapter 2, we provide an overview of IoT and LPWAN technologies. We also discuss different LPWAN standards and present pros and cons for each LPWAN standard.

Chapter 3 discusses the mobility aspect of LPWAN, the current trends, and research related to effect of mobility on LPWAN. In Chapter 4, we discuss the system implementation of the LPWAN network used for our experiments and provide development guidelines for the same. Chapter 5 presents the experimental setup for our experiments followed by an in-depth review of our experimental results in Chapter 6. Chapter 7 discusses the lessons learned and how can these help in designing LPWAN applications. Chapter 8 describes the conclusions of this thesis and future work.

2 LOW POWER WIDE AREA NETWORK (LPWAN): REVIEW

In this section we introduce the basics of LPWAN followed by discussion of different LPWAN technologies and their pros and cons. Then using LoRaWAN network as an example, we discuss the physical structure of LPWAN protocol and its network setup. We also look into different types of end nodes and how they communicate with the gateway.

2.1 OVERVIEW OF INTERNET OF THINGS

The Internet of Things is made up of very intelligent devices that communicate with each other to form a network [13]. These networks along with their software also include the hardware devices which collect environmental data and pass it among other devices. These devices can be used in various places to serve multiple purposes. Some of the examples of their applications as discussed in [16] are alarm systems, smoke detectors, smart meter, parking spot tracker, smart street lights, smart watches, human health monitoring, *etc.* The ever-growing interest in the IoT goes side by side with the decreasing prices of IoT devices over the years.

The communication frequency for IoT devices ranges from 13.56MHz, for applications like contactless payments [39], to 2.4GHz or more for applications that need video streaming. Apart of excluding some of the technologies [20], most of the LPWAN technologies operate in ISM (Industrial, Scientific and Medicine) SubGHz bands. Operating at lower frequencies gives a log of different characteristics when it is compared to those technologies that operate at higher frequencies. The concrete construction in an urban area have less effect on low frequency signal as compared to high frequency signal. It has been also explained in [49] as to how operating in Sub-GHz bands adds both reliability and robustness to the signal. This, combined with the minimal data rate modulation techniques, simple end node and cellular topology enables the IoT devices to transmit and receive data over long range and years.

2.2 OVERVIEW OF LPWAN

In this section, we present an overview of the LPWAN technology. Sub-GHz unlicensed ISM bands (*e.g.*, 868MHz in Europe, and 915MHz in the U.S.) are used to operate LPWAN. The communication range for LPWAN reaches up to 15km in rural areas, and up to 5km in urban areas [11], some reports the range of up to 30km in rural areas [46]. This long range of LPWAN is possible with a new physical layer design that allows for significantly high receiver sensitivities, *e.g.*, -130dBm. To support the long-range communication of LPWAN, its data rate is necessarily low as a few hundred to thousand bits/sec. Thus, LPWAN is better suited for low-power IoT devices that transmit a small amount of data over a long distance, in contrast to short-range technologies such as Bluetooth and Zigbee. In addition, compared to cellular Machine to Machine (M2M) networks that are designed to cover a large area, LPWAN is more cost-effective due to its low hardware price and no need for subscription for service [11].

2.3 MODULATION TECHNIQUES FOR LPWAN

In this section, we briefly discuss the basics of modulation techniques and present the modulation techniques used in LPWAN.

2.3.1 MODULATION FUNDAMENTALS

The process in which a periodic wave also called as the carrier wave is combined with another signal that contains the data to be sent over the channel is called wave modulation. Every signal has three characteristics that can be modulated: frequency, amplitude and phase. Frequency of the wave defines how often does it repeat itself, amplitude gives us the strength or power of the waveform and phase gives us the state of the waveform with respect to time in a given cycle. The final waveform formed from the modulation of carrier and data signal adopts the state of a symbol. This final waveform has a set magnitude, phase and frequency after the modulation. Bit rate of a wave can be defined as

the number of bits sent by the system per unit time while symbol rate is given by the bit rate of the signal divided by the number of bits being sent with each symbol [18]. It has been discussed in [49], that LPWAN gets its long range of communication by a modulation technique that focuses on waveforms with higher energy per bit compared to a waveform with high bit rate. The three basic types of modulation are:

- **Frequency Modulation:** Frequency Modulation is used by FM Radio, radars, telemetry, music synthesis, magnetic tape recording systems, *etc.* Here the signal to be sent is imposed on the carrier signal by changing its frequency. In Figure 2, the data signal to be sent is shown on top. In the middle is the carrier frequency to which the data signal is combined and resulting signal is shown at bottom which is then transmitted.

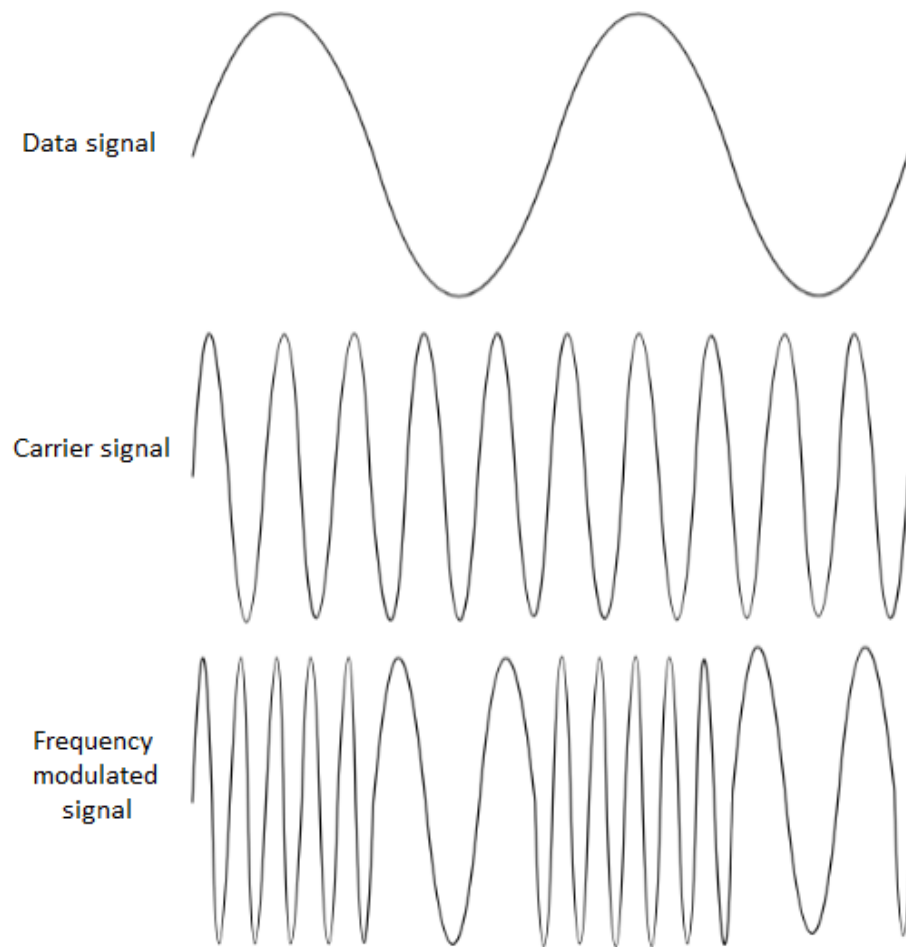

Figure 2: Frequency modulation.

- **Amplitude Modulation:** AM radio is a common example that uses amplitude modulation. In amplitude modulation, the data signal to be sent is imposed on the carrier signal by changing the carrier signal amplitude. In Figure 3, the data signal to be sent is shown at top. In the middle is the carrier signal to which the data signal is to be combined and the final resulting signal is shown at the bottom.

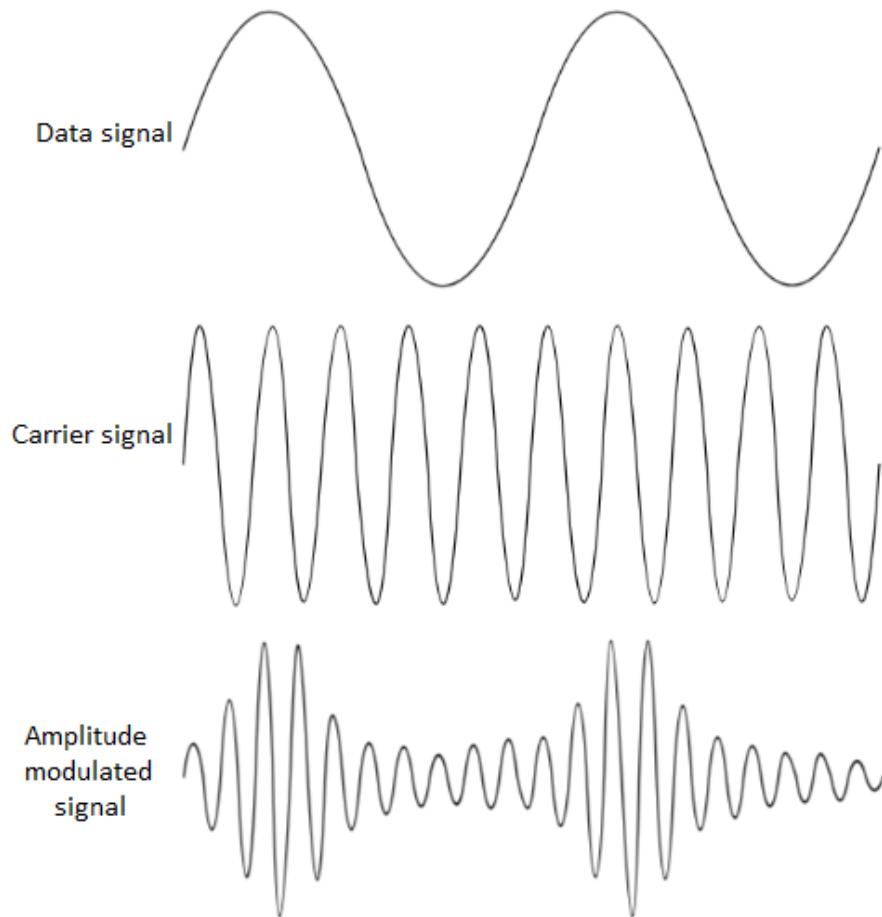

Figure 3: Amplitude modulation.

- **Digital Modulation:** The two modulation techniques mentioned above are used mainly for analog signals which can relate to raw data but cannot represent the 1's and 0's that are used in digital signal. In case of digital modulation variations in amplitude, phase or frequency can be made to represent the 1's and 0's in the data. This gives rise to three schemes: Amplitude shift Keying (ASK), Phase shift Keying (PSK) and Frequency shift Keying (FSK). Figure 4 shows the PSK, FSK and ASK for bit sequence 0010100.

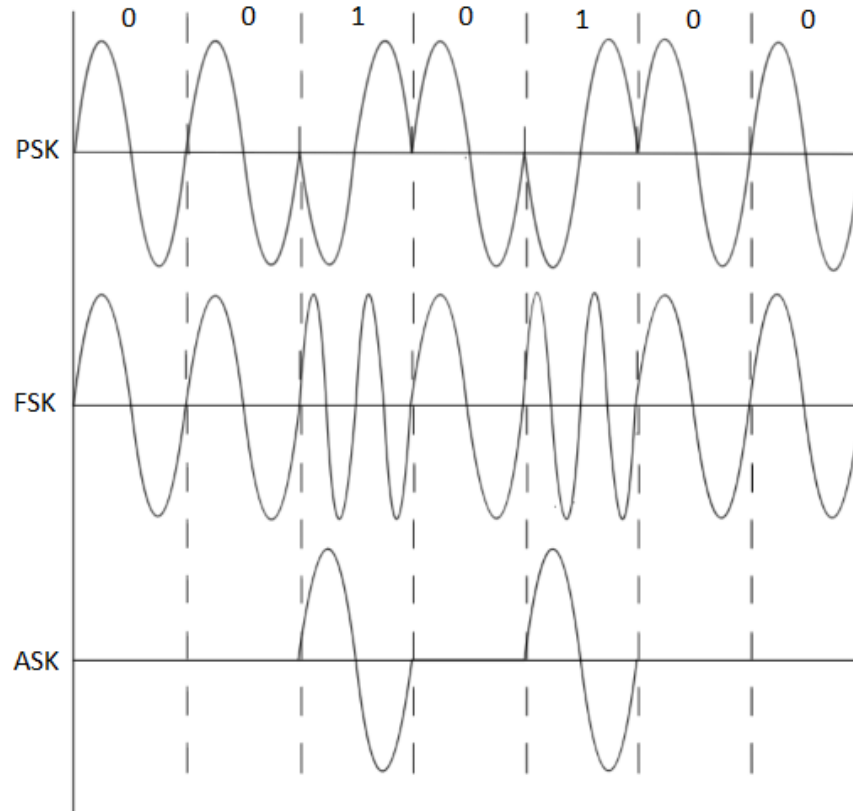

Figure 4: Digital modulation.

Digital modulation can be represented by a constellation graph. In the graph, amplitude is represented as the distance from origin. In the constellation graph for Quadrature Phase Shift Keying (QPSK) in Figure 5, all the signals are at same distance which means that amplitude modulation is not used in this modulation. The phase of the signal is represented by the angle from 'I' axis. QPSK can represent four data points with values 00, 01, 10 and 11. It can provide a data rate of 2 bits/symbol. Quadrature Amplitude Modulation (QAM) is a digital modulation scheme that uses both Amplitude and Phase modulations.

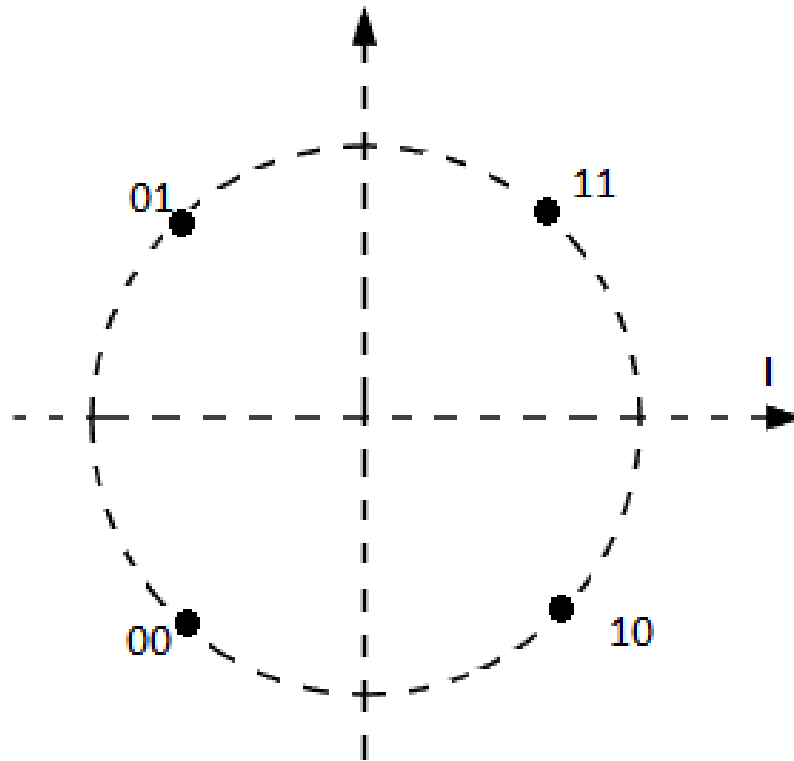

Figure 5: Constellation graph for QPSK.

2.3.2 LPWAN MODULATION

The LPWAN technologies by their characteristics have a range of tens of kilometers to a few kilometers in both rural and urban areas respectively [11]. Most of the LPWAN technologies slow down their modulation rates in order to put more energy in each transmitted bit or symbol so that the receivers are able to decode even the weakest signals without any errors. In general the receiver sensitivity for LPWAN technologies is around -150dBm [11]. The two modulation techniques adopted by LPWAN technologies are the narrowband modulation and the spread spectrum technique.

1. Narrow Band Modulation: In this technique, the signals are encoded at a very low bandwidth of 25kHz or less thus providing a high link budget. The overall spectrum can be shared very efficiently by multiple links as each carrier signal needs a very

low band space for itself. Since multiple links are tightly packed in the spectrum, there is minimum effect of noise on each of these narrowbands. Since the effect of noise is so low it becomes easier for the receivers to decode the receiver signal thus reducing the cost. LPWAN technologies like WEIGHTLESS-P [66] and NB-IoT [2] use narrowband modulation techniques. Some technologies like SigFox [57] use ultra narrow band (UNB) which squeezes the signals further in bandwidths of 100Hz, which further reduces the effect of noise and increasing the number of end devices that can be handled at once. The ultra narrow band restrictions reduce the rate at which data can be send over the channel, thus making it suitable for applications where efficient data transmission is a priority over latency and over a long range [51]. Technologies like TELENSA [61] and WEIGHTLESS-N [66] uses ultra narrow band modulation.

2. Spread Spectrum Modulation: In this technique, the narrow band signal is spread over a much wider frequency closer to the noise level while maintaining the same power level. Since the transmitted wave is very close to the noise level it becomes less susceptible to external interference and also becomes harder to read for intruders. Since the signal is buried below the noise floor, powerful receivers are required to decode it. This technique suffers from inefficient use of spectrum space as a narrow band signal is spread over a wider band. This drawback is overcome by LPWAN technologies having multiple end devices using orthogonal sequences or different channels at the receivers end. This helps to increase the over all network capacity as the end devices using orthogonal sequences or different channels are able to simultaneously decode the received signal. The spread spectrum modulation technique is used in networks which require a higher degree of robustness for interference [50]. Chirp Spread Spectrum (CSS) and Direct sequence Spread Spectrum (DSSS) are variations of spread spectrum techniques used by LoRa [59] and INGENU-RPMA [20] respectively.

2.4 LPWAN STANDARDS

Figure 6 shows comparison of different widely used wireless communication technologies. It can be clearly seen that LPWAN is able to achieve long range communication while using very low bandwidth. We further discuss the pros and cons of widely used LPWAN standards.

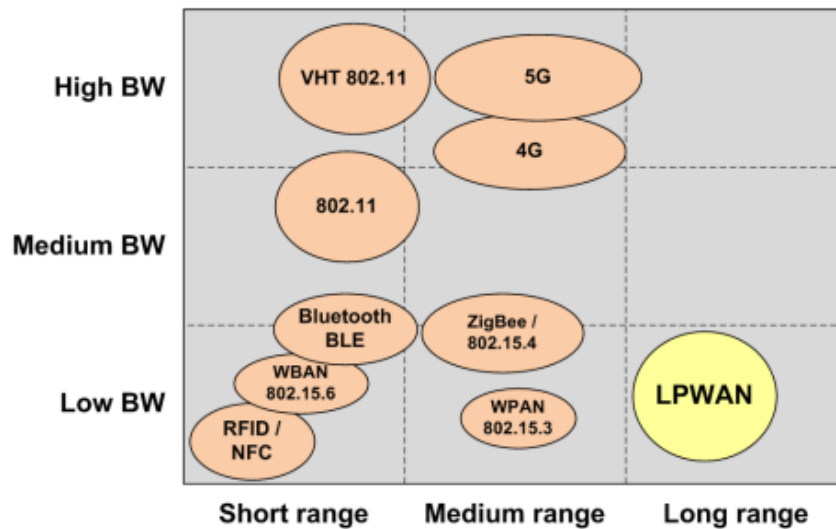

Figure 6: Wireless technologies comparison [62].

2.4.1 INGENU-RPMA

Ingenu is a proprietary LPWAN technology that operates in 2.4GHz ISM frequency bands but has different spectrum regulation for different regions [53]. While other LPWAN technologies rely on properties of SUB-GHz frequency bands for better performance Ingenu does not. On the other hand, Ingenu does not impose and limit on its duty cycle which helps to achieve more network capacity compared to other technologies using the SUB-GHz band, further increasing the network throughput. Random Phase Multiple Access (RPMA) [37] is the physical layer access scheme patented and used by Ingenu. RPMA works on the lines of Code Division Multiple Access (CDMA) by increasing access slot duration for each transmitter. Then RPMA adds a random delay offset for each

transmitter and thus multiple transmitters are unable to access the channel at one. This helps to reduce the overlapping between the transmitter signal further increasing the interference to signal ratio of each link [53]. The RPMA transmitter can adjust its own transmission power so that it is able to connect to the nearest available base station and to limit its interference with other neighboring devices. To receive downlink messages Ingenu uses multiple demodulators to decode and receive the incoming signals. To achieve downlink communication, the base station uses CDMA to broadcast the signal received from end devices. The receiver sensitivity for RPMA can go up to -142dBm and 168 dB link budget [53]. The following summarizes the pros and cons of Ingenu-RPMA.

Pros:

- Better link capacity compared to other LPWAN technologies.
- More area coverage compared to LoRa or SigFox.
- Operates at 2.4GHz with worldwide compatibility.

Cons:

- Short battery life.
- Since it operates at 2.4GHz, it suffers higher interference from buildings, WiFi and Bluetooth.

2.4.2 DASH7

DASH7 Alliance Protocol (D7AP) is a full stack communication standard for wireless sensor networks developed by DASH7 Alliance [67]. DASH7 Alliance is a non-profit corporation developed to work for the development of DASH7 specification. This protocol operates in an unlicensed Sub-1 GHz bands at 433MHz, 868MHz, 915MHz and can achieve communication range up to 2km. The design for DASH7 is based on ISO 1800-7 standard [1], used for radio frequency identification and invented by US

Department of Defense. The design of DASH7 is based on the concept of BLAST (bursty, light with a 256 byte data packet size, asynchronous communication, stealth and transitive which focuses on uplink). DASH7 provides a full stack solution for LPWAN where end nodes can establish communication without being concerned about the complexities of network MAC or physical layers. The default network topology used by DASH7 is a tree topology. However it also gives the flexibility to use a star topology if needed. The asynchronous duty-cycle in DASH7 helps the nodes to function at a lower latency but it increases the power consumption. The MAC protocol for DASH7 requires its nodes to periodically check the communication channel for any downlink messages. This idle listening cost consumes much of the power. DASH7 protocol also has a Low Power Wake-up mode [67] to optimize the power consumption. In this mode the query node sends a bacon advertising the timestamp at which it will send the data. The listening node notices a signal above the noise level and records the timestamp at which data is to be received. The listening node then goes to sleep until the timestamp is reached when it wakes up to receive the data. The network security in DASH7 is provided by 128-bit AES encryption. The following summarizes the pros and cons of Dash7

Pros:

- Good penetration against interference for both outdoor and indoor environment.
- It offers a full stack solution.
- Flexibility of using tree or star network topology.
- Low network latency.

Cons:

- Low latency comes at the cost of battery life and complexity.
- Few commercial solution available as it is newer compared to other LPWAN technologies.

2.4.3 WEIGHTLESS-SIG

Weightless is both the name of technology and a group called Weightless Special Interest Group [66]. It is a proprietary standard developed for machine to machine communication. This standard aims to use the TV white spaces which are unused frequency bands which can be used by secondary devices without interfering with the function of the primary device. The group has presented three LPWAN standards which can function in both licensed as well as license-free spectrum. Each of these standards have different features, power consumption and communication range. While all the standards use symmetric key cryptography for network integrity and authentication. The following summarizes the pros and cons of Wightless.

- **Weightless-W:** This standard has better signal propagation in TV white spaces compared to the other two standards. Weightless-W can transmit data packets of sizes up to 10 bytes at data rates between 1kbps and 10Mbps. Weightless-W supports a wide range of spreading factors and multiple modulation schemes like DBPSK (Differential BPSK) and 16-QAM (16-Quadrature Amplitude Modulation). In order to achieve a longer battery life the end nodes communicate with the base station via a narrow band and lower power levels as compared to the base stations. The drawback of Weightless-W is that the shared access to white TV spaces is granted only for limited regions. To overcome this, Weightless-SIG introduces Weightless-P and Weightless-N which are available for shared access globally.
- **Weightless-N:** This standard is the most power efficient when compared to Weightless W and Weightless-P. It is an ultra-narrow band standard which offers only one way communication from end devices to base station. This standard uses the Differential Binary Phase Shift Keying modulation scheme. The disadvantage of Weightless-N is that due to its one way communication characteristic, its can be used with restricted number of applications which do not need bi directional

communication.

- **Weightless-P:** This is a bidirectional standard which offers two way communication with fully acknowledged data transmission for reliability and capabilities for over the air firmware upgrades. It supports payload sizes up to 48 bytes and can achieve data rates from 0.625kbps to 100kbps. Weightless-P can operate in any frequency band but currently it is defined to operate in only license-exempt sub-GHz frequency bands. It uses Quadrature Phase Shift Keying (QPSK) and Gaussian Minimum Shift Keying (GMSK) to modulate the signals.

Pros:

- Communication range from 2 to 5 plus km.
- With advanced demodulation it can work with existing Radio Frequency technologies with minimal interference.
- Weightless-W and Weightless-P offer bidirectional communication.
- Low speed sensors can use Weightless-N while Weightless-P offers adaptive data rate.

Cons:

- Weightless requires a white space TV spectrum to work for Weightless-W.
- Depending on the standard used, battery life can range from 2 to 10 years.

2.4.4 IEEE 802.11AH

IEEE 802.11ah was developed by the IEEE 802.11ah Task Group also known as TGah. IEEE 802.11ah is a M2M wireless standard designed to bridge the gap between wireless sensor networks and the existing mobile networks. It operates at sub-1 GHz unlicensed

bands worldwide to provide extended range to Wi-Fi networks [25] [3]. The design of IEEE 802.11ah has been adapted from IEEE 802.11ac. It is a highly flexible technology as it supports a range of modulation techniques, bandwidths and coding rates like the Low Density Parity Check and Binary Convolution code. The theoretical throughput for IEEE 802.11ah as shown in [43] is 150kbps up to 1km and 347Mbps at short distances. Different modulation and coding schemes are used based on the channel bands available, to provide different channel throughput. For short distances up to 1km 802.11ah uses a single-hop communication while to enable connectivity to Access Points (AP) which are further away it uses Relay Access Points which connect to the Access Points using two-hop communication. To improve simplicity of the network, 802.11ah uses a hierarchical network of associated stations (STA). Every node in the network is identified using an Association Identification (AID). The Association Identification is divided into four fields: Pages, Blocks, Sub-Blocks and Associated Station. The associated stations with similar values or pages, blocks and sub blocks are merged to form a single group. To avoid collision due to multiple stations transmitting over the same channel, 802.11ah uses a Restricted Access Window (RAW) mechanism. This mechanism works by separating the stations into groups and allowing only the stations belonging to the same group to transmit in a particular time frame. In order to improve the energy efficiency of the nodes, 802.11ah has implemented the Traffic Indication Map (TIM) and the Delivery Traffic Indication Map (DTIM). These are used by the access points to send the group information. All stations that are associated with the transmitted TIM are required to wake up and listen to their respective beacon. 802.11ah also implements a feature called Target Wake Time (TWT) which allows the stations to communicate with their access points and set up a sleep interval after which they can wake up to listen to their beacon. The sleep interval can be anywhere between seconds to years. The following summarizes the pros and cons of IEEE 802.11ah.

Pros:

- Design based on widely used 802.11ac.
- It is highly flexible and can use existing hardware.
- It provides high data rates with long range in both urban and rural areas.

Cons:

- Fairly new technology which is not widely used.
- In TIM scheme the end nodes need to stay awake for duration of beacon thus affecting its battery life.

2.4.5 SIGFOX

Sigfox [57] is a type of cellular technology that provides tailor-made solutions that enables wireless devices to connect to a proprietary base station using very low power and low data rate IP based connection. This is a proprietary technology that is developed and maintained by a French company Sigfox. This technology uses the BPSK modulation technique for transmission. It is an ultra-narrow band signal (small chunks of 100Hz) and the data is encoded by changing the phase of carrier wave allowing the receiver to receive in small slices of spectrum which reduces the effect of noise thus increasing its range and reducing the power consumption. Like LoRa, Sigfox too uses the ISM frequency bands for communication. It operates at 868MHz in Europe and at 902MHz in US. It has been said by Sigfox that a million end-devices can be connected to a single access point and they can provide a coverage of up to 3-10km in urban areas at bitrate of 100bps and 30-50km in rural areas. The low transmission bit rates increase the communication latency and makes it susceptible to interference with other technologies. Sigfox has not implemented any techniques to avoid packet collision and being an ultra-narrowband transmission, it can easily suffer interference from a wideband Sub-GHz technology like LoRa. On the other hand, the base stations are an advanced radio platform which can receive data over

8000 channels at once. Sigfox sends each message three times over different channel frequencies making sure that it is received by at least one of the base stations thus giving high uplink reliability. Sigfox can send 140 uplink messages with maximum of 12 bytes and can receive 4 downlink messages of 8 bytes per day. Taking into account the low data rates and high latency, Sigfox is suited for applications which need low data rates. Being a proprietary and closed technology, external researcher are given minimum freedom to make innovations in this area. The following summarizes the pros and cons of Sigfox.

Pros:

- Low power needed due to absence of receiver circuitry
- Slow modulation helps to achieve higher range making it best suited for simple applications.
- Developed with extensive research in regions of San Francisco and Europe.

Cons:

- Differences in US and European architecture makes it difficult for common testing.
- Not an open source standard.
- Offers only uplink communication.
- Radio Frequency interference is high.
- Offers low security due to 16-bit encryption.

2.4.6 NB-IOT

NarrowBand IoT (NB-IoT) is a LPWAN narrow band radio technology developed and standardized by 3rd Generation Partnership Project (3GPP) [2]. This standard uses cellular communication bands to connect IoT devices and is one of the many Mobile

Internet of Things (MIoT's) technologies designed and standardized by 3GPP. There are three modes of operation for NB-IoT

1. Stand Alone: The signal itself acts as a dedicated carrier.
2. In-Band: Assigned a block within the LTE carrier signal.
3. Guard-Band: Assigned a block in the guard band of LTE carrier signal.

In the stand alone mode the NB-ToT signal occupies an entire 200kHz GSM carrier signal range. In both the in band and guard band mode NB-IoT is implemented as a 180kHz Physical Resource Block (PRB) inside the LTE carrier signal. NB-ToT reduces LTE protocol functionalities to minimum and modifies them to suite the IoT use cases. Once such modification done by NB-IoT to LTE functionality is with the backend system that is used to send information to end devices. Since the broadcasting consumes battery power which is critical in case of IoT devices, the frequency of sending the data and also its size is reduced to the minimum. The communication is optimized to suit the IoT purpose and features like carrier aggregation, dual connectivity that are not needed by IoT devices are avoided. NB-IoT uses QPSK modulation [64] and uses Orthogonal Frequency Division Multiple Access (OFDMA) for downlink transmission and Frequency division multiple access (FDMA) for uplink communication. The maximum data packet size for NB-IoT is 1600 bytes with an uplink data rate of 20kbps and downlink data rate of 200kbps. As discussed in [5] transmitting at the rate of 200 bytes per day, NB-IoT can have a battery life of up to 10 years. The following summarizes the pros and cons of NB-IoT.

Pros:

- Possible to reuse cellular hardware as design is based on LTE.
- Device battery life of more than 10 years.

- Over 100,000 devices per cell.
- Support LTE features like localization, security and authentication.

Cons: Drawbacks of NB-IoT have been discussed in [49].

- Limited message acknowledgment due to downlink capacity.
- Latency increases due to packet aggregation.
- Low performance of NB-IoT when network is under heavy data and voice traffic.
- The technology is very new compared to other technologies and hence commercial applications are not widely available.

Below table compares different LPWAN technologies based on general network characteristics.

Table 7: LPWAN standard comparison [29].

Standard	Weightless -W	Weightless -N	Weightless -P	Sigfox	LoRaWAN	IEEE 802.11ah
Frequency	TV whitespace (400-800 MHz)	Sub-GHZ ISM	Sub-GHZ ISM	868 MHz/902 MHz ISM	433/868/780/915 MHz ISM	License exempt bands below 1 GHz
Channel	5 MHz	Ultra Narrow Band (200Hz)	12.5 kHz	Ultra Narrow Band	868MHz or 915MHz	1/2/4/8/16 MHz
Range	Urban: 5km	Urban: 3km	Urban: 2km	Urban: 3-10km Rural: 30-50km	Urban: 2-5km Rural: 15km	Up to 1km
Transmit Power	17 dBm	17 dBm	17 dBm	10uW to 100mW	EU: <+14dBm US: <+27dBm	1mW to 1W
Packet Size	>10 byte	Up to 20 bytes	>10 byte	12 bytes	Used Defined	7991 bytes to 65535 bytes
Governing Body	Weightless SIG	Weightless SIG	Weightless SIG	Sigfox	LoRa Alliance	IEE 802.11 working group
Topology	Star	Star	Star	Star	Star of Star	Star and Tree

2.5 OVERVIEW OF LORAWAN

In this section, we discuss the general characteristics of LoraWAN and the procedure of creating a LoraWAN network. We also discuss the key parameters that were used for this research. We provide more details on LoRaWAN as we used this LPWAN standard for our experimental study.

2.5.1 LORA

LoRa is a physical layer LPWAN technology developed and patented by Semtech Corporation [54]. LoRa uses its proprietary spread spectrum modulation technique [55] and operates in a Sub-GHz Industrial Scientific and Medical (EU 433MHz & 868MHz, Asia 430MHz and US 915MHz). LoRa uses a technique called chirp spread spectrum (CSS) which spreads a narrow band signal onto a wider bandwidth which helps to achieve the bidirectional communication. Since the signal is spread around the noise floor it is difficult to be detected by intruders and they are unable to differentiate between the actual signal and the noise [51].

2.5.2 LORA ALLIANCE

The LoRa Alliance [28] is a group of companies, developers and manufacturers all over the world that come together to develop a standard for low power, low cost, secure and long-range solution of ever increase domain of internet of things. The LoRa Alliance has been in existence since March 2015. Figure 8 shows the current sponsored members of Lora Alliance.



Figure 8: LoRa sponsor members [28].

Along with being a Sponsored member, the group also offers other levels of membership like Contributor, Institutions, Adopter and Public. Each of these members have different levels of rights and privileges in the group.

The goal of this non-profit organization is to create common standard that can be used to deploy LPWAN all over the world by standardizing knowledge and

interoperability between operators all over the world in a single global standard.

2.5.3 LORAWAN

The LoRaWAN is a communication protocol based on the LoRa modulation technique. LoRa modulation technique was first invented by a French start up Cycleo and then later in 2012 it was acquired by Semtech [31]. LoRaWAN communication protocol belongs to the second layer of OSI model which is the MAC layer (Media Access Control Layer). LoRaWAN as a protocol has various benefits over other wireless communication protocols. Some of the advantages are:

- Bi-directional communication
- End to end security using AES encryption
- Over the air registration of end nodes
- Low power
- Adaptive data rate
- Long range
- Low cost

LoRaWAN networks are implemented as a star topology which are composed of end devices, gateways, network servers and application server. Along with being simple as compared to a mesh network, one of the advantages of implementing star network topology is that it helps with the power consumption of end devices. In a mesh topology, all the devices in network communicate with every other device in the network. Although this helps to increase the range of communication, it does drain the power from end devices since they are in constant state of communication. This problem is solved in case of LoRaWAN by implementing an overlapping star network where the end device

communicates with the best gateway thus decreasing the number of devices it needs to communicate and in turn reducing the power consumption. LoRaWAN also provides the end to end network security for data transmitted from end devices till it reaches the server.

Adaptive Data Rate (ADR) is one of the very important characteristics of LoRaWAN network which helps save power consumption for end devices. This is done by regulating both the data rate and the radio frequency output of the end nodes. This scheme allows the gateways to receive a number of packets at the same time from multiple end nodes [68].

2.5.4 LORAWAN NETWORK PROTOCOL

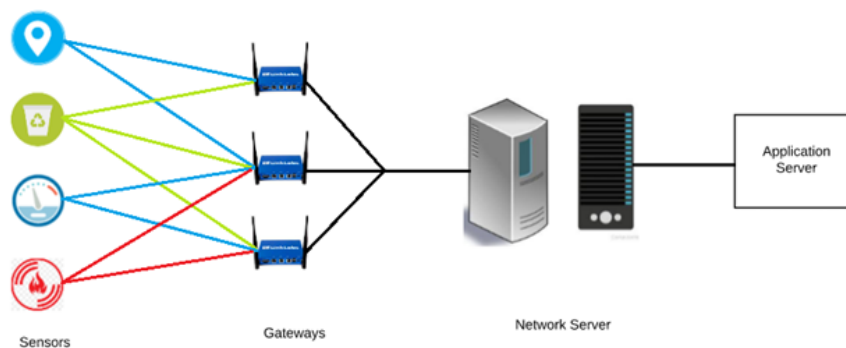

Figure 9: LoRaWAN network structure.

Figure 9 shows the general architecture of LoRaWAN network. The key components in the network are:

1. End Devices:

- The end device, single-hop wireless communication to one or many Gateway(s).
- The host sends the data received from attached sensor to the LoRa module over a UART connection which is then send to the gateway over Sub-GHz RF channel.

2. Gateway:

- It acts as an interface between the end points and backend servers and applications.
- Data from the end device is 'passed through' to the Servers by the gateway.
- Gateways connect to the Network Server via standard IP connection.

3. Network Server:

- It is responsible for data authentication.
- If the data is addressed to the Network Server, data is processed for further use.
- Else data is forwarded to the Application Server.
- The network server is connected to the application server via standard IP connection.

4. Application Server:

- It is the consumer of data.
- It decrypts the data received from the network server
- Multiple Application Server can exist within the same LPWAN Network. Each application server can handle a specific type of data. Example, multiple application servers for electric meter, GPS data, smoke alarms *etc.*

2.5.5 LORAWAN MODULE CLASSES

The LoRaWAN specifications [59] published by LoRa Alliance defines three communication functionalities : Class A, Class B and Class C. Any LoRaWAN devices that are used in the network need to implement one of these three functionalities. In most cases the Class A devices are widely used whereas Class B and C are optional [38].

Figure 10 shows the different communication classes in the LoRa network between the LoRa Mac and application layer.

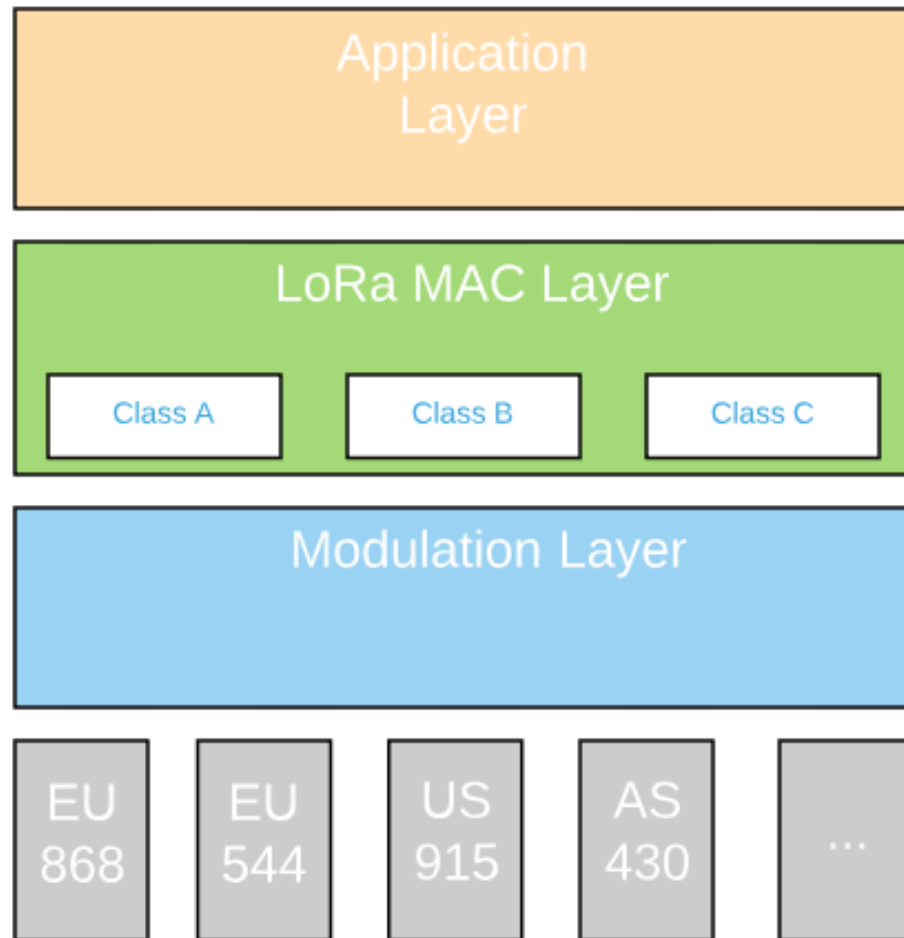

Figure 10: LoRaWAN network layers.

2.5.5.1 CLASS A: The Class A devices follow a bi-directional communication channel with the server. As shown in Figure 11, the end devices are the ones that initiate the communication with the server. After the communication is established by the end device by a transmit message only then can the server respond by sending data packets in two predefined response windows [40]. So, in case server wishes to communicate with the end device, it first needs to wait for the end device to transmit and only then can the server respond. The spreading factor of the connection determines the delay of first TX and RX window while thereafter the next RX window delay is always 200ms [28]. Due to this

behavior, the Class A devices have the lowest power consumption of all the three classes of end device and hence the longest battery life. However, they suffer with a disadvantage of having high latency as every time the server needs to communicate with the device, it first needs to wait for the device to send an uplink message to the server. Class A devices are mainly used with battery powered sensors as they carry low power supply.

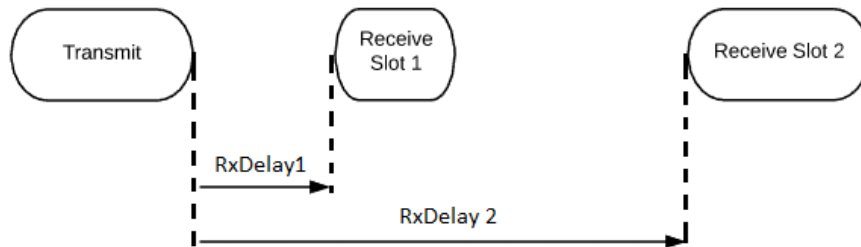

Figure 11: LoRaWAN class A device.

2.5.5.2 CLASS B: The Class B device is also bi-directional like the Class A. In addition to this, the Class B devices have scheduled time slots to receive packets from the server. In this process, first the gateway sends a signal beacon to the end device indicating that it is time for it to receive and then the end device informs the server that it is ready to receive the data. The advantage of Class B devices over Class A is that it has a deterministic latency for uplink and downlink transmission. However, all this process leads to high power consumption and low battery life. Figure 12 shows a snapshot of communication cycle of a Class B device.

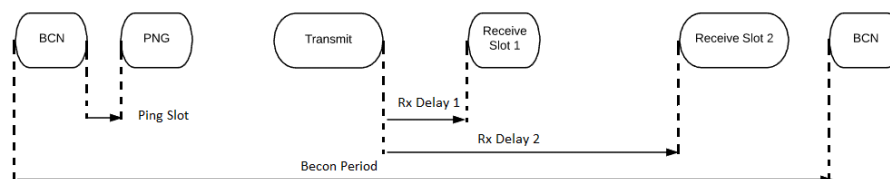

Figure 12: LoRaWAN class B device.

2.5.5.3 CLASS C: The Class C device overcomes the latency drawbacks of Class A and Class B devices as it is continuously available to receive packets. The only time it cannot receive the packets is when it is transmitting. As shown in Figure 13, the device keeps listening during the RX2 slot. As soon as it receives a message from gateway it start listening in the RX1 slot and then switches back to RX2 slot once the reception is over. Due to this nature of the device, the server can initiate communication with the end device whenever it wants. This nature of the Class C device of being always available, leads to the maximum power consumption of all the three devices and so it is primarily suitable for non-battery powered devices [32].

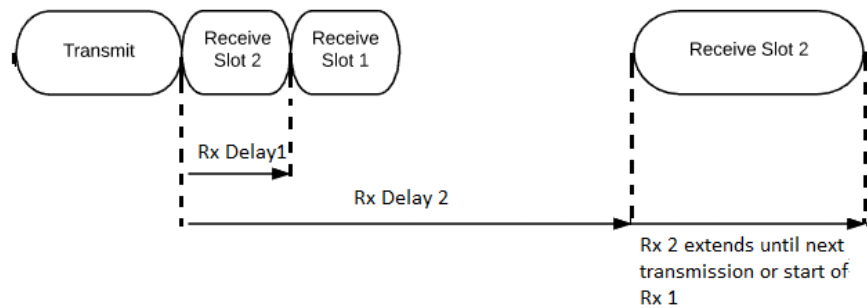

Figure 13: LoRaWAN class C device.

From the description of all three classes of device we can see that the latency of transmission is inversely proportional to the power consumption. The Class A devices have the highest latency but the lowest power consumption and the Class C devices have almost no latency [19] but have the maximum power consumption.

2.5.6 LORAWAN SECURITY

As IoT devices are in most situations connected and operated over a wireless connection, security is of a critical concern. This has been taken care of by LoRaWAN by using an AES 128 bit key [33]. The two important domains in charge of security in LoRaWAN are the network domain and the application domain. The network domain is the one that ensures message integrity between the end-device and the network server. This is done by

a shared 128 bit AES encryption key between the end device and the network server. The application server is the one that decrypts the data received from the end devices which encrypt the data using a shared 128 bit AES encryption key. To summarize, the network server can just authenticate the application data but only the application server can decrypt the data using the shared key. Figure 14 shows how the security is taken care of in a LoRaWAN network.

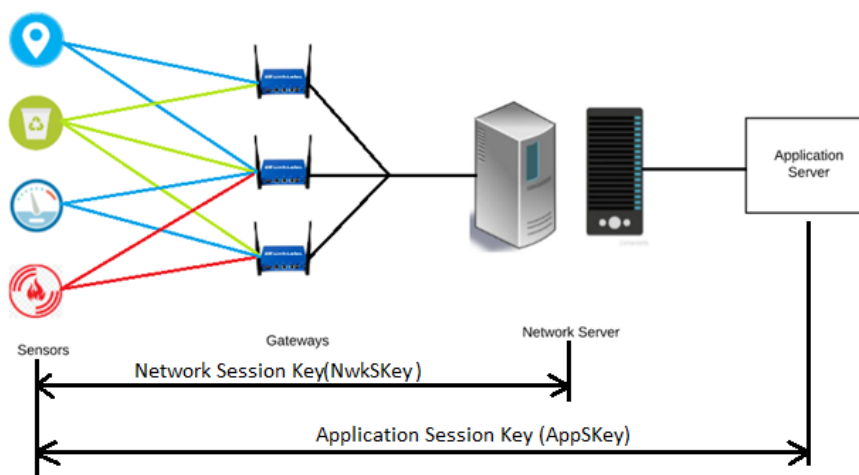

Figure 14: LoRaWAN security.

2.5.7 END-DEVICE JOINING

For an end device to be able to communicate on the LoRaWAN network, it needs to be activated so that it can join the network. The two methods of activating an end device are Over-the-Air Activation (OTAA) and Activation by Personalization (ABP). The following information is required to initiate the activation:

- **Device Address (DevAddr):** The Device Address is a 32-bit address which is unique within the network. The device address helps differentiate each node in the network and thus helps the network to identify the correct key that should be used for decrypting the data from specific end device. The device address is shared between the end-device, network server and application server.

- Network Session Key (NwkSKey): The network session key (NwkSKey) is a 128-bit AES encryption key which is unique for every end device. The network session key is shared between the end device and the network server. The network session key is responsible to maintaining message integrity and thus provides the security to the communication between the end device and network server.
- Application Session Key (AppSKey): The application session key is a 128-bit AES encryption key which is unique for every end device in the network. The application session key is shared between the end device and the application server. This key is basically used to encrypt or decrypt the application data and thus provides security for application data.

2.5.7.1 OVER THE AIR ACTIVATION : The over the air device activation is one of the methods in which an end node can be activated before it is connected to the network. This method provides a large degree of freedom as the end device is unaware of the network it will be in contact with. For this method the device needs the application key, application identifier key and the device identifier key.

The device identifier key is a unique key in the IEE EUI64 space which the manufacture of the device purchases and is added to the device at the time of its initial build. This key then remains unchanged for the lifetime of the device. The application key and the application identifier key is calculated by the user. The authentication process takes place as follows:

1. The end device sends the DevEUI, AppEUI and an optional AppKey to the application server as the join request.
2. If the device is permitted, the server responds by sending a join accept to the device.
3. The join accept message from the application server has the DevAddr and the AppNonce which is used by the end device to generate the network session key and

the application session key.

4. The end device is finally active on the LoRaWAN network.

2.5.7.2 ACTIVATION BY PERSONALIZATION In this method the end device uses the network session key and application session key to join the network. The LoRaWAN specification clearly states that the network session key and application session key should be unique for every device in the network. It further states that the process of deriving these keys should be unique so that they cannot be replicated in any way by a publicly available information like a node address. This guideline clearly aims at establishing the needed security for the LoRaWAN networks. The drawback of this method is that the end device is not able to join other networks without re-calculating the network session and application session keys.

3 MOBILITY IN LPWAN

As described in Chapter 2, there are numerous experimental studies on the performance of LPWAN. However, to the best of our knowledge, there are few works on the mobility effect on LPWAN. In this chapter, we introduce some of the experimental studies on the mobility effect, and compare with our work.

Petajajarvi *et al.* have performed various experiments to evaluate the coverage, scalability and Doppler effect in mobile environment on the performance of LPWAN [47]. Doppler effect is a phenomenon where if the source of the wave is moving in a certain direction then the frequency observed by the receiver is different than the one being radiated. The observed frequency depends on the speed and the direction in which the source is moving. Two experiments were conducted to study the effect of Doppler effect on LPWAN communication as shown in Figure 15. In the first setup, the end device was attached to a lathe inside a laboratory which would continuously subject the end device to varying angular velocities. In the second setup, the end device was mounted on a car which was driven on a motorway while it passed the gateway.

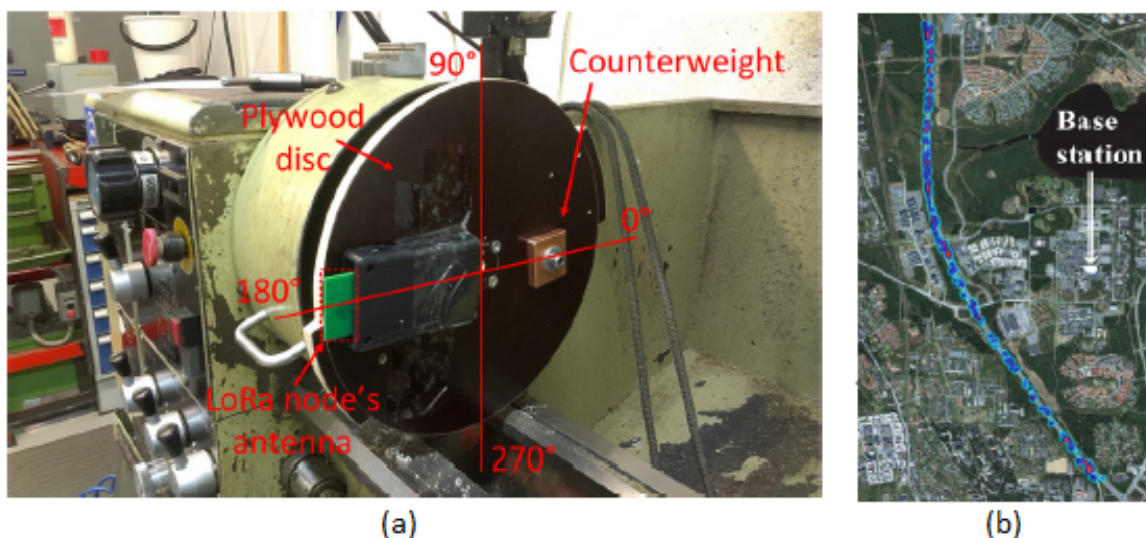

Figure 15: Experimental setup: (a) end device subjected to angular velocity and (b) heat map of car driven on motorway across the gateway [47].

For both the setup the spreading factor of end device was set to 12 and the car velocity was over 38km/hr. While the end device is moving at an angular velocity, at different angles its radiation patterns keep changing with respect to the gateway. Initial set of results was recorded while keeping the end device stationary at angles 0° , 90° , 180° and 270° . It was noted that average packet transmission success ratio of 97.5% was achieved. After this, the lathe was set to rotate and 300 data packets were sent before changing the rotation speed. The authors showed that the reliability of the network decreases at angular velocities greater than 750 RPM and the end device had a lower receiver signal strength while in motion compared to what it had while being stationary. To study the effect of linear velocity, measurements were taken in the outdoor environment while keeping the car stationary on the motorway and also while it was in motion along the motorway. The authors demonstrated that the network had an average packet success ratio of approximately 98% when the car was stationary while the success ratio dropped to 28% when the car was moving at the speed of 100km/h. This work was conducted at a similar time as our work [45] and coincides with our results in that mobility has a negative effect on the LPWAN performance. However, in contrast to this work, our work also analyzes the effect of minor mobility such as human/animal mobility.

Lingling *et al.* have performed experiments to study the feasibility of using a LPWAN network to design a sailing monitoring system [27]. This is one of the very few experiments conducted over a water surface to study the performance of LPWAN. Two sets of experiments were conducted. In the first scenario both the gateway and end device were mounted on moving boats, and the second where the end node was on a moving boat while the gateway was installed on a building 1km away from the shore on land. The authors showed that while the boats moved at speed of 20km/h to 37km/h, the packet loss rate was only 0.34% when the boats were within 400m of each other. After conducting the second phase of experiment with the gateway fixed at top of the building, they demonstrated that the network coverage experienced over the water surface is lower

compared to the coverage achieved when the gateway was mounted on a 20m high building. They also show that the packet loss rate was under 6% at the range of 2km in zones with less interference from obstacles whereas the packet loss increased to over 34% in areas with high interference. This work was performed at a similar time as our preliminary work [45]. Similar to our work, this paper studies the relationship between the mobility effect and the distance to the gateway.

Petajajarvi *et al.* in [46] conducted experiments on performance of LPWAN in an indoor environment with the motive to evaluate the feasibility of using an LPWAN network to design applications for human wellbeing. The experiments were conducted inside a University campus which spanned 570 x 320 meters and had steel and concrete constructions. The end node was attached to one of the researchers who would move inside the university performing his daily tasks like visiting a restaurant for lunch, standing in line and paying for the food *etc.* For the experiments the end node was configured to have the bandwidth of 125kHz, maximum spreading factor of 12 and transmission power of 14dBm. The spreading factor and transmission power were varied for different set of experiments. The node was set to sent data to the gateway every 5 seconds. The gateway was mounted outside the university building at the height of 24m above the sea level. All experimental data were collected while the end node attached to the researcher's arm was in motion. The results demonstrated that while using the maximum spreading factor and transmission power, 96% of the packets send by the end node were received by the gateway and an indoor communication range of around 300m can be achieved. In the second phase when the end node was set to minimum specification, it was still able to reach the remote part of the facility however there were strong variations in packet error rates due to the building structure and other obstacles blocking the link. The experimental results show that packet error rate was 5% when the end node was moving at the distance of 75m to 150m from the gateway. They further study the effect of using different spreading factor on the coverage and packet error rate of

the mobile node. The results show that while the node is moving and the spreading factor of 7 is used, the packet error rate increases from 2.9% at 55m from gateway to 12.6% at 310m and goes out of coverage when it moves at distance of 370m. However when the spreading factor of moving node is increased to 10, the packet error rate at distance of 55m is 2.5% and increases to 36% when the node reaches the distance of 310m. The authors also showed that the performance of LPWAN for mobile end nodes in an indoor environment is unstable and depends highly on the communication settings. It is also important to note that in case of mobile end nodes, using the maximum spreading factor does not always achieve the most stable communication and regardless of the settings used the network does experience some amount of packet loss even at very short distance. This research is focused on measuring different network parameters while the node is in motion to evaluate the performance of LPWAN. Although the experimental results were recorded while the end node was in motion, the authors have not discussed the effects of mobility on the network parameters.

Our preliminary work [45] on the mobility effect has sparked a number of subsequent works. Ismail *et al.* discussed different challenges faced while designing an LPWAN network in [23]. The authors discussed about challenges like security, adaptive data rate, real time communication, network coverage, inter technology communication and LPWAN's support for mobility scenarios. The authors states that with ever increasing growth of IoT in UAV's and different machinery like tractors in agriculture makes mobility a focus of LPWAN research while designing new application. The authors further states that mobility affects the power consumption of end devices making it necessary to design mobility algorithms to make the networks more power efficient. In [8], Carvalho *et al.* evaluate the performance of LPWAN application in real world applications under stationary and mobility state. The experiments are aimed to find the delays in network experience when nodes are in motion. The authors experiments go to show that nodes experience fixed delay of 250m/s in both mobile and fixed scenarios.

Authors further state that the transmission delay can be reduced by using a better Internet connection for time critical applications.

4 SYSTEM IMPLEMENTATION

4.1 SYSTEM ARCHITECTURE

We design a completely functional Symphony Link test platform to conduct experiments for evaluating the performance of LoRaWAN system under various mobility settings. The components selected according to the availability and suitability of this research are :

- Symphony LoRa module LL-RXR-27
- Symphony gateway LL-BST-8
- Symphony link conductor
- Symphony LoRa evaluation board
- Prelude LoRa evaluation program
- Dell Precision M4400 as host terminal

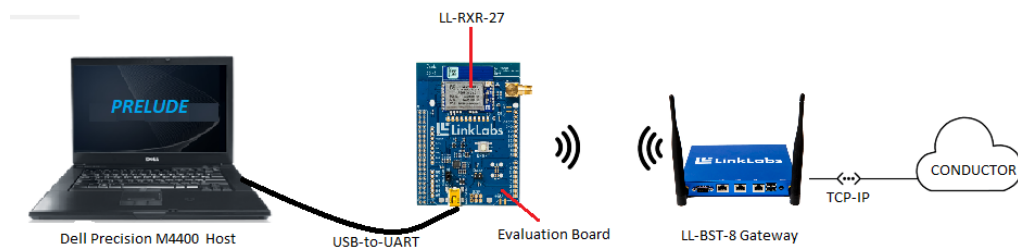

Figure 16: System architecture.

Figure 16 shows the interface of all the components used for conducting experiments in this research. The host terminal being used is the Dell Precision M4400. The host runs a script which would send a fixed number of messages to the end node and also record the response from the gateway for each of the message sent and store these responses in a data file for further analysis. In order to perform functions like firmware upgrade, registration of new end node, communication with the node, Link Labs has

designed a GUI application called Prelude which runs on the host terminal. All the functions performed by Prelude can also be performed by using command line functions. The host terminal connects to the LL module evaluation board via a USB connection. The Lora Module LL-RXR-27 is attached to the LL Module evaluation board built by Link Labs. This evaluation board has a USB-to-UART bridge which makes it possible to control the LoRa module by using a PC over USB. This feature serves our purpose of controlling the module using a host PC. The LoRa module sends and receives data to and from the LL-BST-8 gateway over the ISM frequency band. The gateway is connected to a cloud based application called the Conductor. The Conductor is responsible for keeping track of LoRa applications, gateways and the end nodes currently being used in the network. It also acts as a database for all the uplink and downlink data send between the end node and the gateway. The details of components shown in Figure 16 are discussed below.

4.2 LORA MODULE

Symphony LoRa Module LL-RXR-27 is a bi-directional, low-power and highly integrated transceiver module. This module achieves maximum range with minimum power consumption by using frequency modulated chirp which is Semtech's LoRa™ modulation. It operates in 868MHz ETSI frequency bands of 915MHz ISM frequency bands. The key features of LL-RXR-27 are:

- Transmit Power : 250mW / 24dBm
- Receiver sensitivity: -137dBm
- Tx Peak Current: 480mA
- Rx Peak Current: 4mA
- Sleep current: less than 10uA (unregulated) and less than 1uA (regulated)

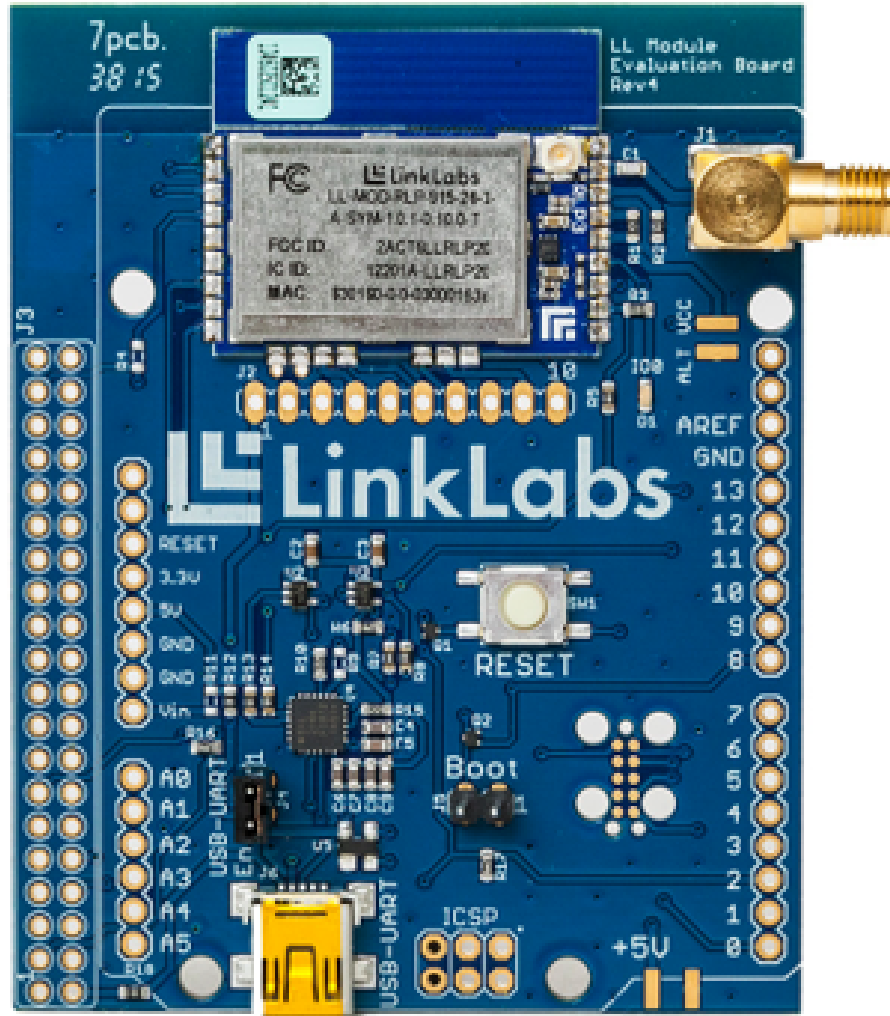

Figure 17: LL-RXR-27 evaluation board.

LoRa evaluation board for LL-RXR-27 is shown in Figure 17. The evaluation board is equipped with USB-to-UART bridge which allows us to control the module from a PC which acts as an external microcontroller, by using a USB connection. For our experiments the module operates in the Symphony Link mode which is a proprietary LPWAN technology based on LoRa and developed by LinkLabs. Figure 18 shows the general architecture of Symphony Link network.

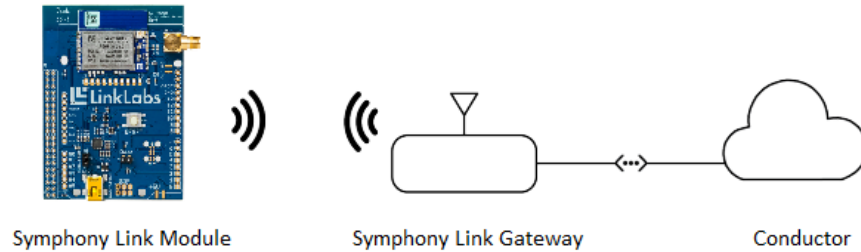

Figure 18: Symphony link network architecture.

Symphony link is an over-the-air protocol which follows a star network topology based on slotted Aloha scheme [74]. The connection between the pre-configured module and the gateway is quick as the module automatically connects to any Symphony Link gateway that is in range. The gateway acts as a mediator between the end node and the conductor as it relays uplink messages from end nodes to the conductor and relays the downlink messages from the Conductor to the specifically addressed end nodes. The modules operating in Symphony Link mode can be easily controlled using predefined high-level functions inside the host microcontroller code. The various network metrics like data rate, transmission power, encryption, *etc.* are automatically set by handshaking between the gateway and the module. This helps to improve the range, network capacity and also helps to reduce the power consumption.

In our experiments we use the Dell Precision M4400 laptop which is running Ubuntu 14.04 LTS 64bit operating system. The laptop is equipped with 7.8GB of RAM , 250GB hard drive space and Intel Core 2 Duo CPU P8600 and cpu speed of 2.4GHz. The laptop is an external host which communicates with the module using a USB to UART (Universal Asynchronous Receive/Transmit) connection. The physical connection between the host and end node and the library of commands that are send to the UART connection are together referred as the host interface.

4.2.1 MESSAGE FLOW IN SYMPHONY LINK

With our aim to understand the network performance with end-to-end delay as one of the metric, it is important to study how message flow takes place between the end node and the external host microcontroller. Figure 19 shows how messages are exchanged between the Symphony link module and the external host.

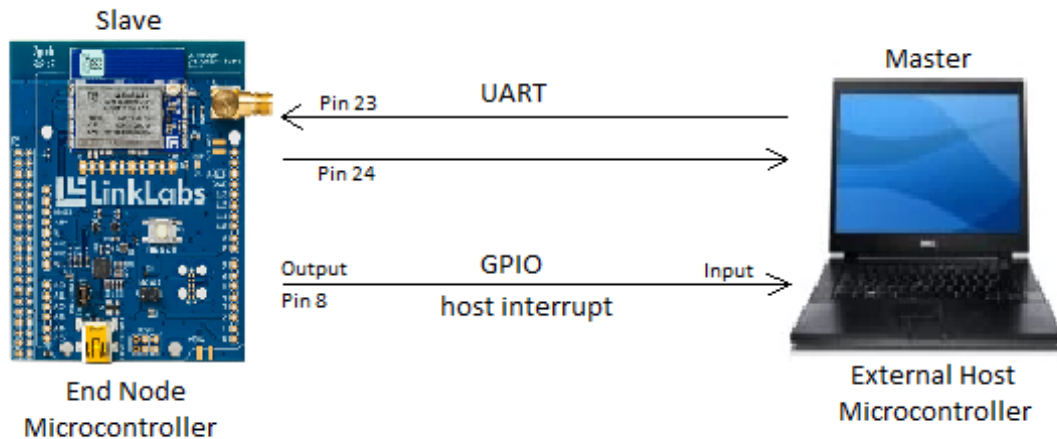

Figure 19: Message flow between host and end node.

The external host follows a master-slave setup where the end module acts as a slave and the external micro-controller acts as the master. In Symphony Link both the slave and master units are allowed to initiate the communication flow but they follow different mechanisms. The master slave communication is made up of two types of data packets: Response Packets and Command Packets. The slave sends the response packets while the master sends the command packets. When the communication is initiated by the master, it sends only one UART command packet at a time and has to wait to receive a response from slave unit before sending the next packet. The response time for the slave is set to 300ms for each command packet received. When a slave wants to initiate the communication it cannot send the data packets directly. It first needs to send a polled interrupt request from its Pin 8 to the host micro-controller unit. Pin 8 is also called the Host Interrupt General Purpose Input/Output line. The host recognizes the interrupt from

the slave and checks the reason of the interrupt from slave by checking which IRQ flags are set. It then issues further commands and takes appropriate actions. The UART configuration between master and slave configuration:

- Data : 8bit
- Baud Rate : 115200bps
- Parity : None
- Flow Control : None
- Stop Bits : 1bit

4.2.2 UPLINK MESSAGE

The maximum message length supported by symphony link is 256 bytes. Uplink messages can be of two types, acknowledged and unacknowledged messages. When an acknowledged uplink message is sent, the gateway confirms the receipt of the uplink message after which the next uplink message can be sent. In case of unacknowledged uplink message the gateway does not confirm the message receipt and the end node can transmit the next message as soon as the transmission queue is empty.

- Acknowledged Message: When an acknowledged uplink message is sent from the host micro controller, the module receives the contents and makes an attempt to connect the last know gateway that it had connected. If the module is able to successfully transmit the message it waits for the acknowledgment from the gateway and after it receives the acknowledgment the `IRQ_FLAGS_TX_DONE` flag is set. In case the acknowledgment from gateway is not received the end node attempts to send the message two more times. If the all three attempts are unsuccessful then the `IRQ_FLAGS_TX_ERROR` flag is set and it notifies the external host of the failure.

- Unacknowledged Message: In this case the module does not wait for a response from gateway to acknowledge the uplink message. Once the module finishes sending the message it just sets the `IRQ_FLAGS_TX_DONE` flag.

4.2.3 CODE IMPLEMENTATION FOR UPLINK MESSAGE

In this section, we give an overview of code implementation for uplink communication of how an uplink message is sent from host to the module and then to the gateway.

1. Whenever the send command is sent by the host to the end node, the suffix of sent command is checked and appropriate mode is set. In Listing 1, we can see that the send mode is set to `MODE_SEND_ACK` when an acknowledged send command is executed and the mode is set to `MODE_SEND_UNACK` when an unacknowledged send command is used. The type of mode being set is the only variable that informs the gateway where it needs to acknowledge the message it receives from end node or no. As we see in the further steps, this mode is embedded into the header of the data packet and is sent to the gateway.

Listing 1: Setting message mode.

```
// main.c
else if (strcmp(long_options[option_index].name, "send_ack")
    == 0)
{
    buff = optarg;
    mode = MODE_SEND_ACK;
}
else if (strcmp(long_options[option_index].name,
    "send_unack") == 0)
{
```

```
buff = optarg;
mode = MODE_SEND_UNACK;
}
```

2. As seen in Listing 2, after setting the mode, a switch case is executed depending on the value of the mode variable. If acknowledged, the mode is set then the message buffer and length are passed to the function `ll_message_send_ack`, and in case of unacknowledged mode, it is sent to the function `ll_message_send_unack`.

Listing 2: Switch case.

```
// main.c
switch (mode)
{
case MODE_NONE:
break;

case MODE_SLEEP:
i32_ret = ll_sleep();
print_ll_ifc_error("ll_sleep", i32_ret);
break;

case MODE_SEND_ACK:
if (use_hex)
{
len = strlen(buf)/2;
buffer_to_hex(buf);
}
else
{
```

```
len = strlen(buf);
}

i32_ret = ll_message_send_ack((uint8_t *)buf, len);
print_ll_ifc_error("ll_message_send_ack", i32_ret);
printf("ll_message_send_ack returned %d\n", i32_ret);
break;

case MODE_SEND_UNACK:
if (use_hex)
{
len = strlen(buf)/2;
buffer_to_hex(buf);
}
else
{
len = strlen(buf);
}

clock_t start1 = clock();
i32_ret = ll_message_send_unack((uint8_t *)buf, len);
print_ll_ifc_error("ll_message_send_unack", i32_ret);
printf("ll_message_send_unack returned %d\n", i32_ret);
break;

default:
fprintf(stderr, "ERROR: Invalid mode %d\n", mode);
}
```

3. As shown in Listing 3, the functions `ll_message_send_ack` and

ll_message_send_unack checks if the data buffer or its length are not null and sends the buffer, its length and the send message mode, OP_MSG_SEND_ACK or OP_MSG_SEND_UNACK whichever was set in step 1, to hal_read_write function. The return type of ll_message_send_ack is the value returned by hal_read_write which is the response that it receives from gateway. This value is either 0 or a negative number. If the value is 0, it is an indication from the gateway that the transmission was successful while a negative value indicates that the packet was lost.

Listing 3: Function: ll_message_send_ack and ll_message_send_unack.

```
// ll_ifc_symphony.c
int32_t ll_message_send_ack(uint8_t buf[], uint16_t len)
{
    if (buf == NULL || len <= 0)
    {
        return LL_IFC_ERROR_INCORRECT_PARAMETER;
    }
    return hal_read_write(OP_MSG_SEND_ACK, buf, len, NULL, 0);
}

int32_t ll_message_send_unack(uint8_t buf[], uint16_t len)
{
    if (buf == NULL || len <= 0)
    {
        return LL_IFC_ERROR_INCORRECT_PARAMETER;
    }
    return hal_read_write(OP_MSG_SEND_UNACK, buf, len, NULL, 0);
}
```

```
}

```

4. The function `hal_read_write` as shown in Listing 4, is responsible for a final error checking for data buffer and buffer length. If there are errors then it returns an incorrect parameter error which is returned back to the `main.c` and is notified to the user. If there are no errors then data buffer, buffer length, the operation mode and message number are sent to `send_packet` function. The function `recv_packet` is then called, which returns the response from the gateway for the message that was sent and returns it back. The variable `message_num` helps keep a track of successful and failed acknowledgments received from the gateway.

Listing 4: Function: `hal_read_write`.

```
// ll_ifc.c
int32_t hal_read_write(opcode_t op, uint8_t buf_in[],
    uint16_t in_len, uint8_t buf_out[], uint16_t out_len)
{

    int32_t ret;

    // Error checking:
    // Only valid combinations of buffer & length pairs are:
    // buf == NULL, len = 0
    // buf != NULL, len > 0
    if (((buf_in != NULL) && ( in_len == 0)) || (( buf_in ==
        NULL) && ( in_len > 0)))
    {
        return(LL_IFC_ERROR_INCORRECT_PARAMETER);
    }
}
```

```

}

if (((buf_out != NULL) && (out_len == 0)) || ((buf_out ==
    NULL) && (out_len > 0)))
{
    return(LL_IFC_ERROR_INCORRECT_PARAMETER);
}

// OK, inputs have been sanitized. Carry on...
send_packet(op, message_num, buf_in, in_len);
ret = recv_packet(op, message_num, buf_out, out_len);
message_num++;
return(ret);
}

```

5. The `send_packet` function shown in Listing 5, is responsible for creating the data packet header before sending it to `transport_write` function. This function also computes the checksum of the data being sent and then sends both the header with its data buffer and the checksum to the `transport_write` function.

Listing 5: Function: `send_packet`.

```

// ll_ifc.c
static void send_packet(opcode_t op, uint8_t message_num,
    uint8_t *buf, uint16_t len)
{
    #define SP_NUM_ZEROS (4)
    #define SP_HEADER_SIZE (CMD_HEADER_LEN + SP_NUM_ZEROS)
    uint8_t header_buf[SP_HEADER_SIZE];

```



```
uint8_t checksum_buff[2];
uint16_t computed_checksum; send_packet
uint16_t header_idx = 0;
uint16_t i;

// Send a couple wakeup bytes, just-in-case
for (i = 0; i < SP_NUM_ZEROS; i++)
{
    header_buf[header_idx++] = 0xff;
}

header_buf[header_idx++] = FRAME_START;
header_buf[header_idx++] = op;
header_buf[header_idx++] = message_num;
header_buf[header_idx++] = (uint8_t)(0xFF & (len >> 8));
header_buf[header_idx++] = (uint8_t)(0xFF & (len >> 0));

computed_checksum = compute_checksum(header_buf +
    SP_NUM_ZEROS, CMD_HEADER_LEN, buf, len);

transport_write(header_buf, SP_HEADER_SIZE);

if (buf != NULL)
{
    transport_write(buf, len);
}
```

```

checksum_buff[0] = (computed_checksum >> 8);
checksum_buff[1] = (computed_checksum >> 0);
transport_write(checksum_buff, 2);

}

```

6. The `transport_write` function shown in Listing 6, is the one that writes the buffer that it receives from the calling functions onto the COM port of the host which is then send to end node via USB-UART bridge and then transmitted to the gateway.

Listing 6: Function: `transport_write`.

```

// ll_ifc_transport_pc.c
int32_t transport_write(uint8_t *buff, uint16_t len)
{
    DWORD bytes_written;

    if (!WriteFile(g_tty_fd, buff, len, &bytes_written, NULL))
    {
        fprintf(stderr, "Error writing tty\n");
        return -1;
    }

    if (bytes_written < len)
    {
        return -1;
    }

#ifdef DEBUG_PRINT_EVERY_BYTE_TX_RX

```

```

    int i;
    for (i = 0; i < bytes_written; i++)
    {
        printf("W: 0x%02x\n", buff[i]);
    }
#endif

    return 0;
}

```

Studying the message flow between the end node and gateway helped us write appropriate code for the host microcontroller which is able to record the end to end delay for the time at which the end node sends the packet and receives the packet receipt acknowledgment from the gateway. To do this we record the time from the message is sent and the time when the end node sends the `IRQ_FLAGS_TX_DONE` or `IRQ_FLAGS_TX_ERROR`. Listing 7 shows a snapshot of the host code implementation where the code starts recording the time at which message was sent and keeps track of the flags that are currently set. As soon as the end node receives acknowledgment from the gateway and sets the `IRQ_FLAGS_TX_DONE` it breaks out of the loop and records the time elapsed in micro seconds thus giving us the end to end delay for that message. Counting the number `IRQ_FLAGS_TX_ERROR` flags over the number of messages send gives us the packet loss ratio.

Listing 7: Function: end to end delay code implementation.

```

// main.c

    clock_t start = clock();

    i32_ret = ll_message_send_ack((uint8_t *)buf, len);
    print_ll_ifc_error("ll_message_send_ack", i32_ret);

```

```
printf("ll_message_send_ack returned %d\n", i32_ret);

/* End to End delay : Start */
uint32_t flags_to_clear = 0;
uint32_t flags_read = 0;
int8_t ret;
clock_t start = clock();
i32_ret = ll_message_send_ack((unit8_t *)buff, len);
// Check what flags are set, and clear some if we want

ret = ll_irq_flags(flags_to_clear, &flags_read);

while (!((IRQ_FLAGS_TX_DONE & flags_read) || (IRQ_FLAGS_TX_ERROR &
    flags_read))) {
    ret = ll_irq_flags(flags_to_clear, &flags_read);
}

clock_t stop = clock();
double elapsed = (double)(stop - start) * 1000 / CLOCKS_PER_SEC;
print_ll_ifc_error("ll_message_send_ack", i32_ret);
printf("ll_message_send_ack returned %d\n", i32_ret);
printf("Time elapsed in ms: %f\n", elapsed);

/* End */
}
```

4.3 LORA GATEWAY

Symphony Gateway LL-BST-8 is an industrial grade gateway developed by Symphony Link, which can connect to thousands of Symphony Link modules. It can perform various LPWAN features like uplink and downlink communication, security updates and many more while using the Symphony Link protocol. The gateway can operate with 3G cellular, WiFi or 4G LTE for data backhaul, thus making it the right choice for conducting experiments in the outdoor environment where WiFi is unavailable. The key features of the LL-BST-8 gateway are:

- Data connection via ethernet, GSM or WiFi
- Interference mitigation algorithm
- LoRaWAN and Symphony link ready
- IP67 Water proof outdoor enclosure available
- Adaptive data rates
- Operates in 868MHz or 915MHz bandwidth



Figure 20: LL-BST-8 gateway.

4.3.1 GATEWAY CONFIGURATION

Configuring the gateway for first use involves the following steps:

1. The gateway can operate in three modes Ethernet, WiFi and Cellular. We use the WiFi mode as we connect the gateway to WiFi so that it can communicate with the conductor application. We connect the WiFi antenna to the WiFi jack and 915MHz antenna to the Ultra High Frequency (UHF) antenna jack.
2. After powering on the gateway, connect the PC with the gateway using an Ethernet cable.
3. Navigate to gateway's local page in the browser to 192.168.3.3 and login using the username 'admin' and password 'password'.

The screenshot displays the LinkLabs Gateway Administrator web interface. At the top, the header includes the LinkLabs logo, the word 'GATEWAY', and a user dropdown menu for 'Gateway Administrator'. The main content is divided into several sections:

- Gateway Status:** Displays key information such as Gateway Name (Gateway xA474), Mode (Symphony Link™), and Public Internet Routing (No Connection).
- Symphony Link™ Settings:** Shows connection status (Connected), Network Token (ec378736), Registration (Registered), and Software Version (1.3.1).
- Network Configuration:** Features tabs for 'Wireless', 'Wired Network', and 'Administration Port'. The 'Wireless' tab is active, showing settings for the WiFi interface, including MAC address (04:F0:21:17:44:2B), SSID (rog_2G), IP Address Configuration Method (DHCP), and IP Address (192.168.50.25).

Figure 21: Gateway configuration.

4. The gateway local page as shown in Figure 21 is reached which provides with options like connect to Internet, register gateway with conductor, software updates and also shows the current status of gateway.
5. Since we are using WiFi, we connect the gateway by selecting the wireless tab and using the WiFi SSID and shared key. The Link Status changes from Disconnected to Activated once the gateway is able to successfully connect to the internet.
6. Next step is to register the gateway to the Conductor platform. This can be done by clicking the Register Gateway button on the gateway homepage.
7. Doing so pops up a conductor login box. If this is a new user, then the create user button is clicked to create a new user or else the user credentials are entered.
8. For a new application we can create a new network or use an already existing Open Gateway network. On clicking the create network button the conductor creates a new network with unique name and adds it to the list. This name can be modified if needed.
9. Once the gateway is registered the prompt disappears and the registration section on the gateway homepage shows that the gateway is registered.

4.4 CONDUCTOR-DATA PLATFORM

It is a proprietary cloud based service application developed by LinkLabs. It provides the network management and data services for the Symphony Link protocol. It also provides a very dynamic data infrastructure which makes building a Symphony link application as easy as making a connection with an API. Although it can be deployed in any server farm, it is currently being deployed inside Amazon Web Services. Conductor also manages the settings for Symphony Link network, database storage, message routing, certificates, sessions and security infrastructure.

4.5 PRELUDE

Prelude is a graphical interface application developed by LinkLabs to register the nodes to the gateway and to establish communication between the host micro-controller and the end node. It also shows the current status of IRQ flags as they change while the end node communicates with the gateway. Since this application runs on the host computer all the functions that can be performed by this application can also be performed by using high level command line functions from host terminal. Figure 22 shows the view of prelude running on host computer.

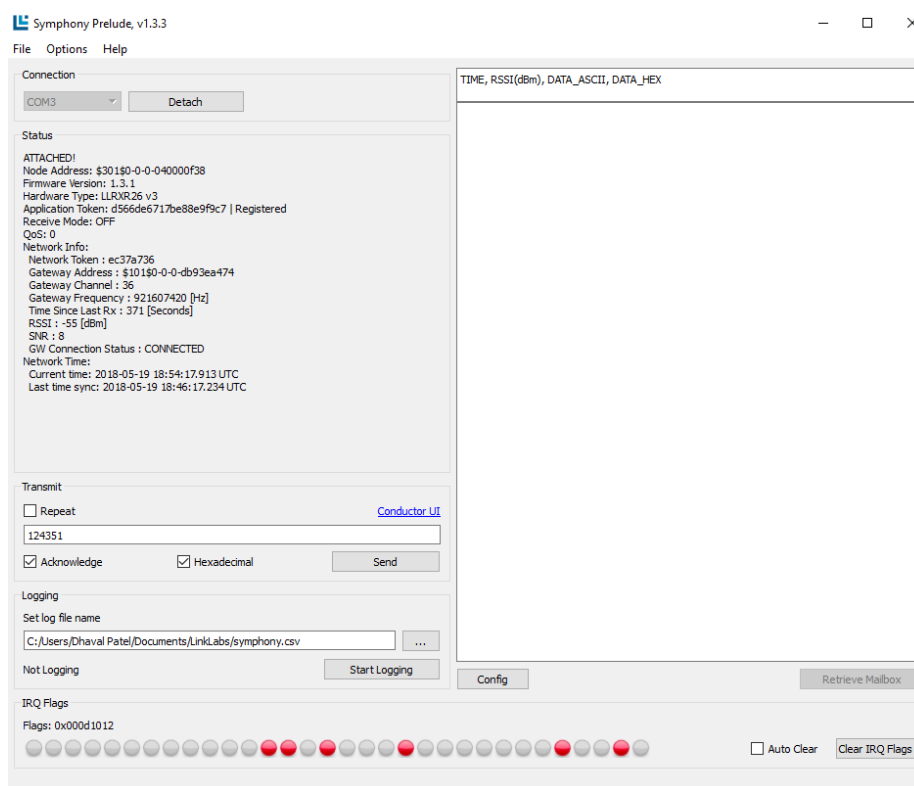

Figure 22: Prelude symphony link application.

4.6 LESSONS LEARNED

The following lessons were learned while implementing the LPWAN network using Symphony Link protocol:

- It is important to check the hardware for faults before implementing the communication code. Using the GUI application Prelude helped us to identify faulty antennas and modules before implementing the communication code. We learned this the hard way as first attempted to implement the software code assuming that there were no issues with the LoRa modules only to find out later that they were faulty.
- In the current code implementation, every time the module disconnects from the gateway, it resets the network statistics to the values of the new connection and the next message send is marked as the first message. Due to this issue, we had to conduct a set of experiments again if the module disconnects before it finishes the data transmission. This issue was noticed at the time we started conducting the experiments and hence it can be an issue that can be fixed in future implementations.

5 EXPERIMENTAL SETUP

For this experimental study, we adopted the Symphony Link that is built on LoRaWAN which is the LPWAN platform of LoRa Alliance [28]. The following summarizes justifications for selecting Symphony Link for this experimental study.

- Utilizing per-packet acknowledgment, Symphony Link has lower packet error rates.
- Symphony Link is flexible in adjusting the duty cycle allowing us to send more packets at a given time.
- It is more flexible in terms of controlling the transmission power and data rates.
- The fixed maximum transmission unit (MTU) size of 256 bytes of Symphony Link allows us to send packets of varying sizes.

The experiments were performed in both indoor and outdoor environments. The indoor experiments were carried out in the hallway (3m by 130m) on the third floor of a building. A person continuously moved at a normal walking speed from one end to the other of the hallway for 20 mins for each measurement (*i.e.*, for each packet size, and for each distance to the gateway). The gateway was initially installed in the middle of the hallway and it was placed outside the building to increase the distance to the gateway. The distance was varied from 0 to 0.3 miles. To compare the results with the non-mobility case, we fixed the location of the end node and repeated the same experiments. A vehicle was used as a means to test for high mobility in an outdoor environment. An empty parking lot was exploited for this experiment in which a circular test track was defined to maintain a constant vehicle speed. An end node was installed on top of the vehicle (Figure 23). The vehicle utilizing its cruise control system continuously traveled on the circular test track with varying speed from 5mph up to 15mph for 20mins for each measurement. The gateway was placed at varying distances from the center of the test

track, *i.e.*, 0.1, 0.3, and 0.5 miles. Due to the low height of the LPWAN gateway and buildings on the campus, the maximum range was about 0.6 and 0.4 miles in the outdoor and indoor settings, respectively.

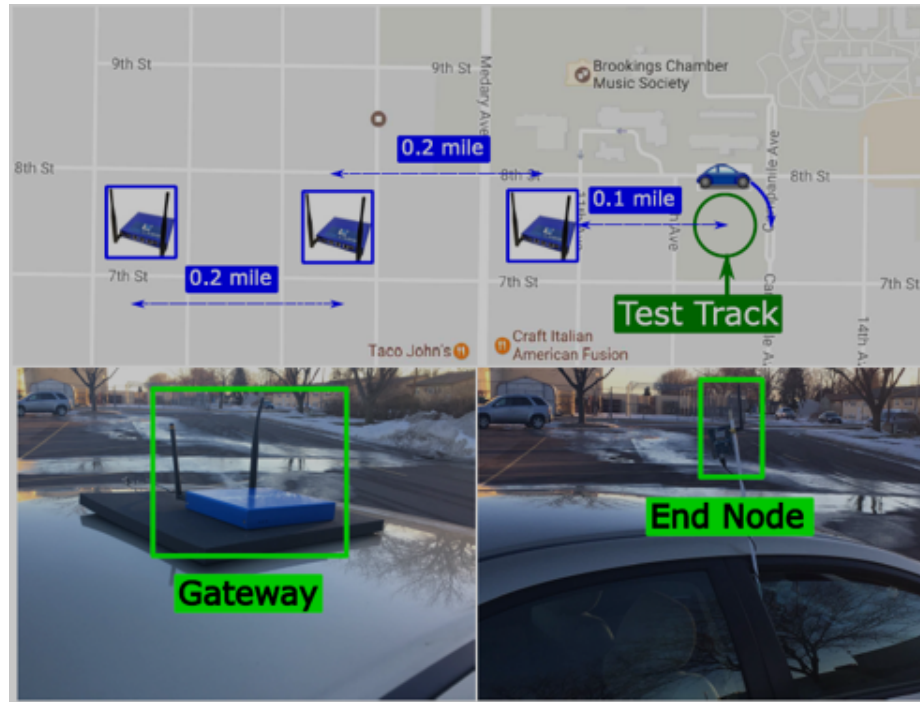

Figure 23: Experimental setup.

6 EXPERIMENTAL RESULTS

In this section, we evaluate the performance of LPWAN in mobile environments. The performance was measured in terms of end-to-end delay and packet loss rates. The end-to-end delay refers to the elapsed time from the point where a packet transmission request is made until the acknowledgment packet is received from the gateway. The two-performance metrics shown in Figure 24 measured by varying the following parameters: vehicle speed (for outdoor experiments), packet size, and distance to the gateway.

```
Iteration No : 62
Open /dev/ttyUSB0 baud 115200
Link Labs Firmware Type: 0003.0001
Link Labs Hardware Type: LLRXR26 v3
Link Labs Version: 1.3.1
Link Labs interface version: 0.4.1
Link Labs UUID: $301$0-0-0-040000f38
ll_message_send_ack returned 0
Time elapsed in ms: 151.327000
Open /dev/ttyUSB0 baud 115200
Link Labs Firmware Type: 0003.0001
Link Labs Hardware Type: LLRXR26 v3
Link Labs Version: 1.3.1
Link Labs interface version: 0.4.1
Link Labs UUID: $301$0-0-0-040000f38

Stats:
num_send_calls           = 62
num_pkts_transmitted    = 63
num_gateway_scans       = 0
num_collisions           = 0
num_ack_successes       = 62
num_ack_failures        = 1
num_sync_failures       = 0
num_canceled_pkts_ack   = 0
num_canceled_pkts_csma = 0
num_rx_errors           = 0
```

Figure 24: Code result.

6.1 IMPACT OF PACKET SIZE - INDOOR MOBILE ENVIRONMENT

Results from experiments performed in the indoor mobile environment are presented. For this experiment, human mobility was applied to investigate the impact of mobility with varying packet sizes. The objectives were to understand how the mobility influences the performance of LPWAN and to discover the correlation between the impact of mobility and the packet size. The gateway was placed in the middle of the hallway.

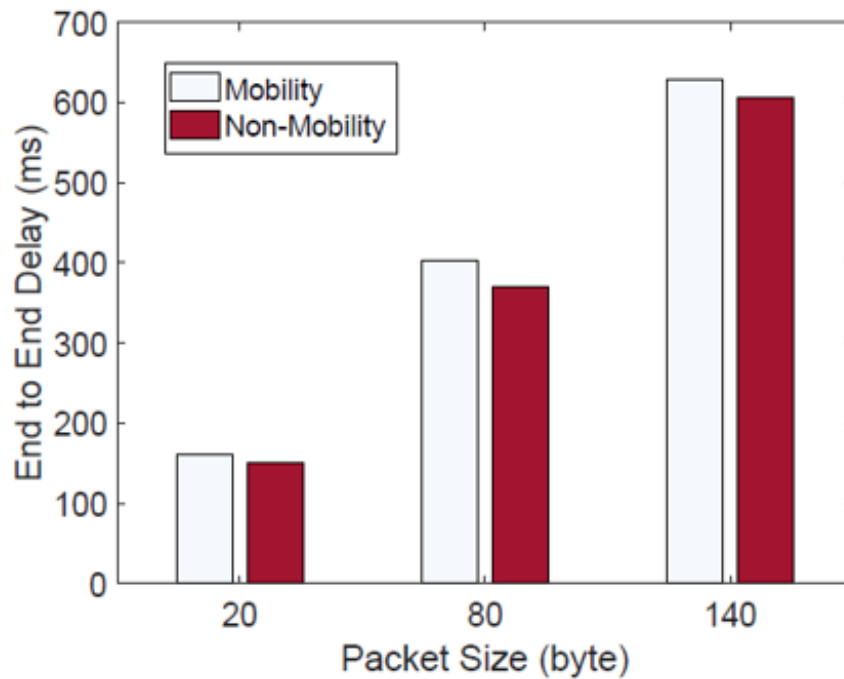

Figure 25: Effect of mobility with varying packet sizes (indoor).

Figure 25 displays the average end-to-end delay of packets transmitted for 20 mins at the predefined data rate according to the Symphony Link protocol. The results indicate that the average end-to-end delay increased as we made the packet size larger. This result coincides with recent research [4]. A key observation was that regardless of the packet size, the average end-to-end delay for the mobility case was consistently greater than the non-mobility case. More specifically, compared with the non-mobility case, increases of 5.7%, 8.9% and 3.7% in the average end-to-end delay were observed for packet sizes of

20, 80, and 140 bytes, respectively, for the mobility case. Although the differences seem small, interestingly, when the distance to the gateway was greater, the average end-to-end delay for the mobility case significantly increased (Figure 26 and 27). These results suggest that the end-to-end delay of LPWAN is affected by even minor human mobility, and is more substantially impacted when the distance to the gateway is increased. Another interesting observation was that the packet size did not contribute much to the effect of mobility. It was also worthy to note that the packet loss rates were 0% regardless of the packet size when the gateway was placed close to the end node (*i.e.*, in the building).

6.2 IMPACT OF DISTANCE - INDOOR MOBILE ENVIRONMENT

This section presents in-depth evaluation of the correlation between the mobility impact and the distance to the gateway. For this experiment, we placed the gateway outside of the building at 0.1 and 0.3 miles away from the building. With the default packet size of 80 bytes, we measured the average end-to-end delay and packet loss rates for both the mobility and non-mobility cases. The CDF graphs of the end-to-end delay for the distances of 0.1 mile and 0.3 mile are depicted in Figures 26 and 27, respectively. When we placed the gateway at 0.1 mile away from the building, the average end-to-end delay significantly increased by 57%. The average end-to-end delay further increased by 87% when the distance was increased to 0.3 mile. The two figures display distinctive end-to-end delay differences between the mobility and non-mobility cases.

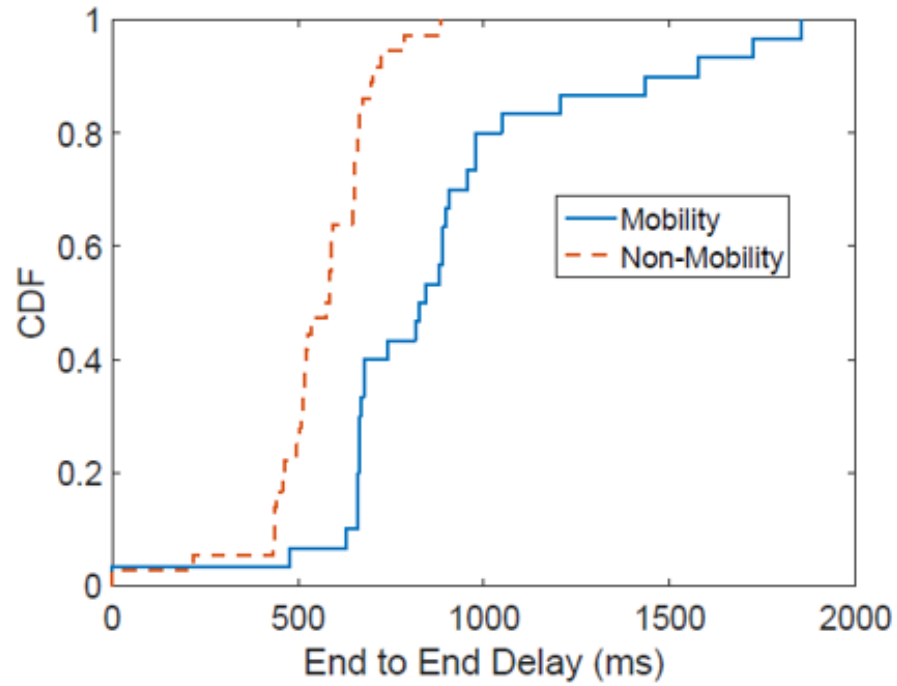

Figure 26: Effect of mobility with distance of 0.1 mile (indoor).

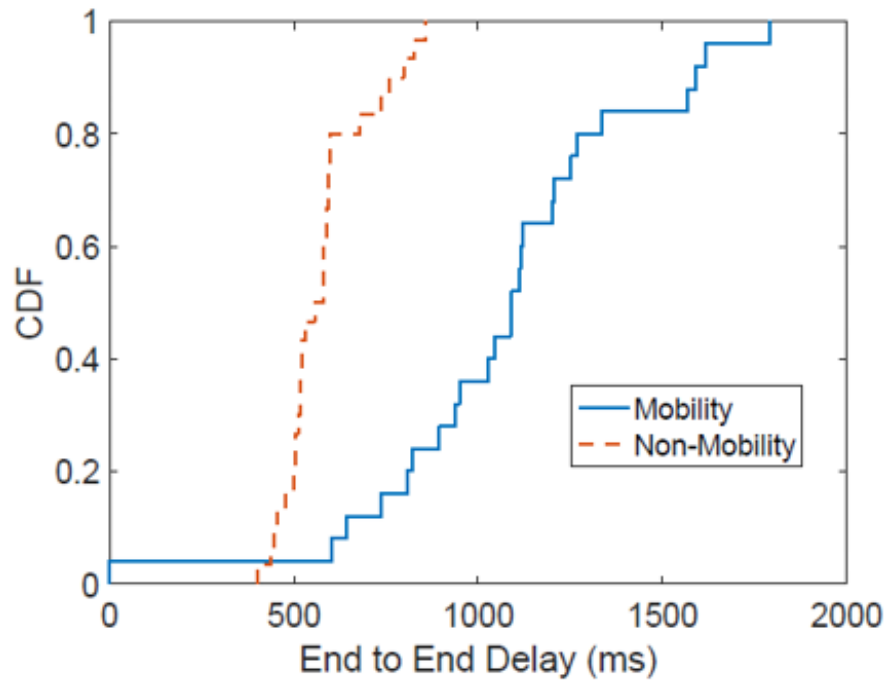

Figure 27: Effect of mobility with distance of 0.3 mile (indoor).

We then measured packet loss rates for varying distances to the gateway. Recall

that packet loss rates were 0% when the gateway was inside the building. The results for the increased distance to the gateway are very interesting (Figure 28). As the gateway was placed farther away from the end node, the packet loss rate was significantly impacted even by the minor human mobility. More specifically, for the non-mobility case, the packet loss rate was less than 2% regardless of the distance to the gateway. However, for the mobility case, the packet loss rates substantially increased, *i.e.*, up to 10%, and 20% for the distances of 0.1 miles, and 0.3 miles, respectively.

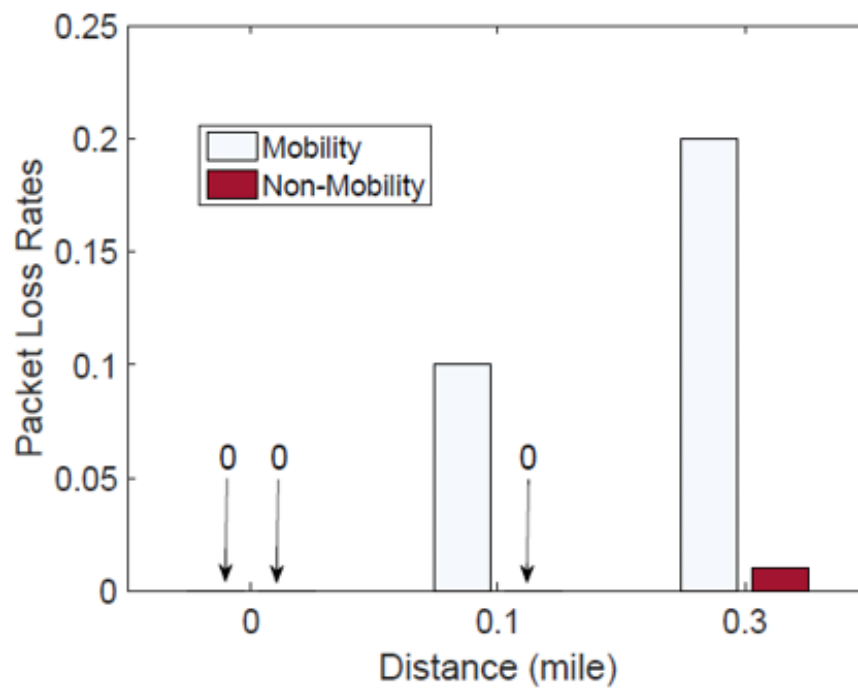

Figure 28: Effect of mobility on packet loss rates (indoor).

6.3 IMPACT OF PACKET SIZE - OUTDOOR MOBILE ENVIRONMENT

We evaluated the impact of mobility on the performance of LPWAN in the outdoor environment. The gateway was placed 0.1 mile away from the center of the test track. We then measured the average end-to-end delay and packet loss rates by varying the vehicle speed and packet size.

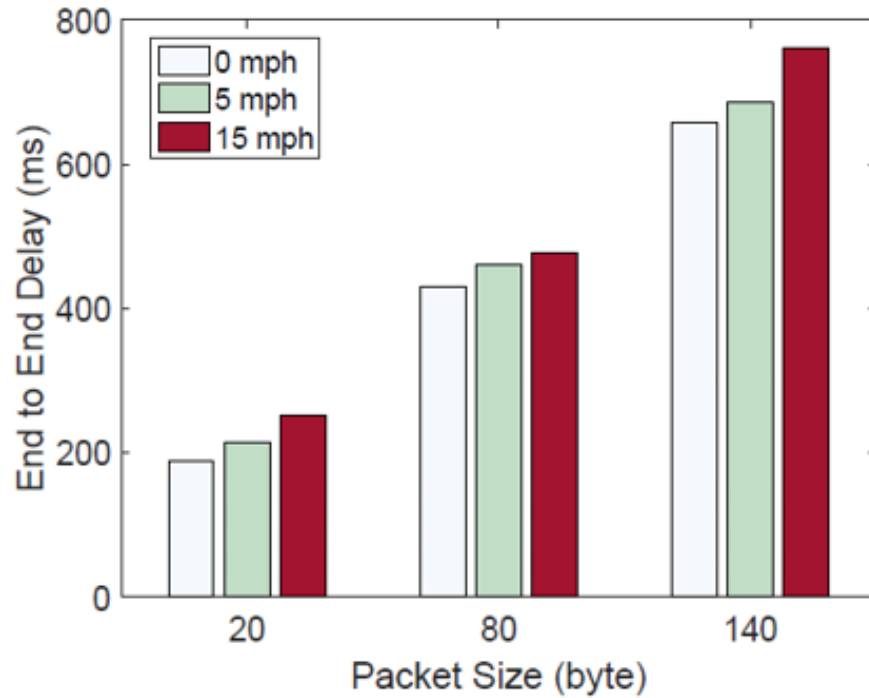

Figure 29: Effect of mobility on packet sizes (outdoor).

Figure 29 depicts the results. A strong correlation between the mobility (*i.e.*, vehicle speed) and average end-to-end delay was found: the average end-to-end delay increased as the vehicle speed increased. Similar to the results from the indoor environment, this mobility impact significantly increased as the distance to the gateway increased (Figure 32). Compared with the results from the indoor experiments, we obtained smaller end-to-end delay for the outdoor experiments for all packet sizes due primarily to the signal obstruction.

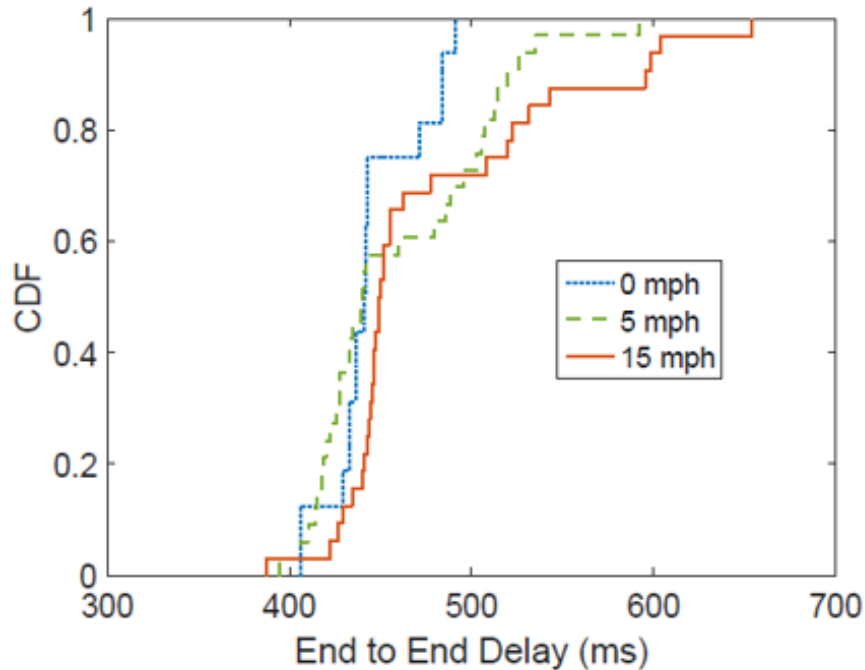

Figure 30: CDF for end-to-end delay for variable vehicle speed with 80-byte packet at 0.1 mile (outdoor).

The CDF graph of the end-to-end delay in Figure 30 (for the packet size of 80 bytes) more clearly illustrates the effect of the vehicle speed on the end-to-end delay. As it is shown, at the distance of 0.1 mile, 10% of the end-to-end delay measurements were greater than 450ms, 500ms, and 600ms for 0mph, 5mph, and 15mph, respectively.

Figure 31 displays packet loss rates for different vehicle speeds and packet sizes. It was discovered that there is a strong correlation between the vehicle speed and packet loss rates: the packet loss rates increased as the vehicle speed increased. It was also interesting to note that even the low vehicle speed substantially impacted the packet loss rates. We were not able to find a relationship between the packet size and the packet loss rates in this experiment.

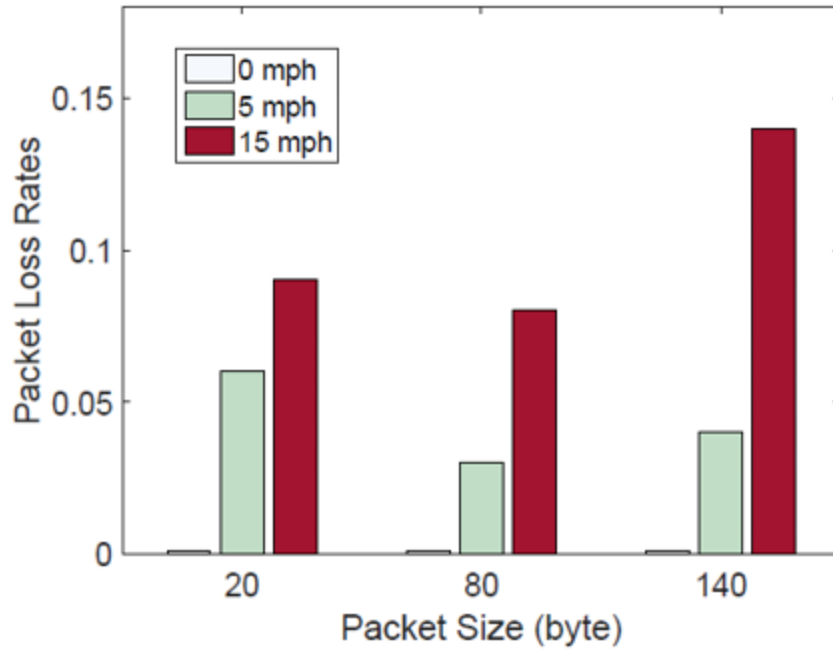

Figure 31: Effect of mobility on packet loss rates (outdoor).

6.4 IMPACT OF DISTANCE - OUTDOOR MOBILE ENVIRONMENT

To investigate how the distance to the gateway influences the degree of the mobility impact, we placed the gateway at different distances, *i.e.*, at 0.3 mile and 0.5 mile away from the center of the test track. We then measured the average end-to-end delay and packet loss rates.

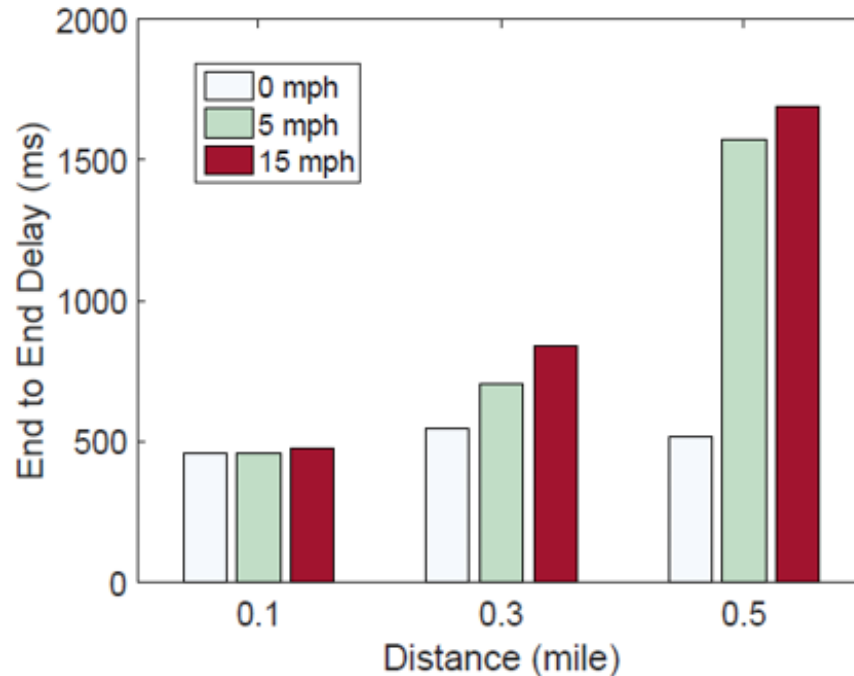

Figure 32: Effect of mobility with varying distance (outdoor).

Figure 32 depicts the results. As shown, the average end-to-end delay increased with higher vehicle speed regardless of the distance to the gateway. An interesting observation was that the average end-to-end delay more sharply increased with the longer distance to the gateway. More specifically, when the gateway was close to the center of the test track, the effect of mobility was observed but the degree was not substantial in comparison with that for the longer distance to the gateway: when the vehicle speed was increased to 15mph, increases of up to 4%, 52%, and 225% in the average end-to-end delay were observed for the distances of 0.1, 0.3, and 0.5 miles, respectively. To illustrate the distributions of the end-to-end delay measurements, the CDF graph of the end-to-end delay at the distance of 0.3 mile is displayed in Figure 33.

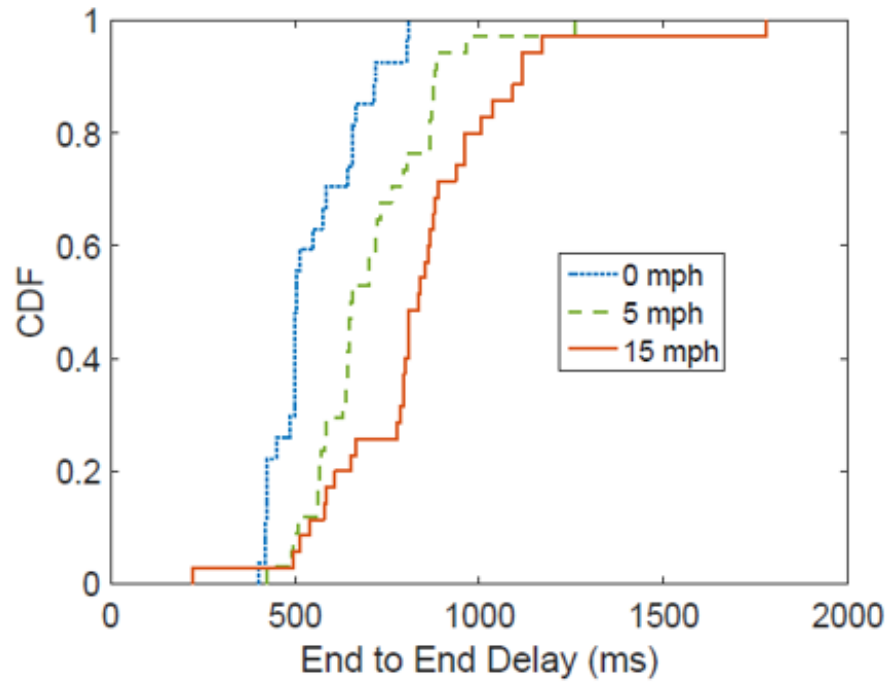

Figure 33: CDF for end-to-end delay for variable vehicle speed with 80 byte packet at 0.3mile (outdoor).

An interesting observation was that, in comparison with the results for the distance of 0.1 mile (Figure 30), the gaps between lines are larger indicating more significant increases in the end-to-end delay when the distance to the gateway was longer. We also observed that the mobility impact was greater in an indoor environment compared with the outdoor environment. The reason is that the indoor environment had higher signal disruption due to obstacles and more sources of interference.

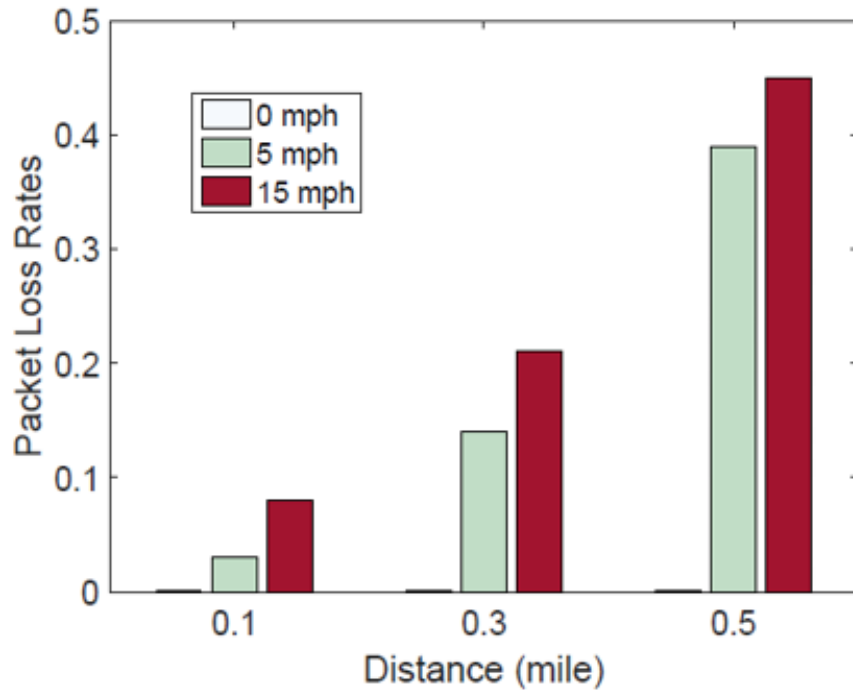

Figure 34: Effect of mobility on packet loss rates (outdoor).

Figure 34 depicts the results of packet loss rates. There is a clear correlation between the packet loss rates and the vehicle speed in the outdoor environment: as we increased the vehicle speed the packet loss rates increased. It was also observed that this mobility impact became greater when the distance to the gateway increased. Regardless of the distance to the gateway, when the vehicle speed was 0mph, the packet loss rate was extremely low. Also note that in the outdoor environment, even with the small vehicle speed (*i.e.*, 5mph), the packet loss rate was significantly affected.

7 LESSONS LEARNED

In this section we discuss the various scenarios in which results of this research can play an important role during the design phase of the project. This section we talk about three LPWAN applications and show how the results of this research can be used in designing LPWAN applications.

7.1 AGRICULTURE LIVESTOCK TRACKING

New technological innovations and ideas can help agriculture industry to better manage the available resources and also results an increase in yields and profit. LPWAN application in the field of agriculture can perform various tasks like:

- Remotely controlling self-driving tractors can help to reduce cost [14].
- Sensors attached to livestock can help the farmers keep tracks of their location and health. Sick animals can be separated from the heard thus stopping any further spread of infection to other animals [17].
- Sensors deployed to track the health of soil can notify farmers of various irregularities like if the soil becomes to acidic or too dry for farming [17].

Based on our results on performance of LPWAN in outdoor environment, here are some considerations needed to be assessed before trying to design a LPWAN based agricultural application.

- Type of sensors and location : Different sensors are used to gather different data and they also vary in sizes. It is no easy for farmers to mount a big sensor collar onto the animals. If the animals being tracked are in an area with dense vegetation or if the population of the animals is high, it might degrade the performance on the application.

- How often is data gathered : It is not necessarily true that if more data is gathered by a sensor the better it is. More data often means a larger data packet size or frequent transmissions. It is seen from our experiments that a larger data packet size has considerable impact on mobility performance of the sensors.
- Range Needed : It has been concluded from our experiments that more distance the data packet needs to travel the more is the impact of mobility on network performance.
- Type of Livestock being tracked : Different animals move at different speed. For example sensors tracking a horse would often be moving at a higher speed than a sensor tracking a cow. The former network will suffer from the impact of mobility on network delay and packet loss rate as discussed in our experiments.
- Gateway Location : It is also crucial to consider how the gateways that communicate with the end nodes are deployed in the field. It has been seen from our experiments that a gateway placed inside a concrete building does suffer from interference due to walls.
- Geographical Location : Application performance can also be affected if the area in which it is deployed has dense vegetation cover like big trees or small hills which can interfere with network performance.

7.2 HEALTHCARE MONITORING

Health care monitoring and Health applications is one of the places where a sensor network can help in saving lives and also making the healthcare experience much peaceful for patients and their patients. Some of the benefits of using sensor networks for healthcare monitoring are :

- Monitor every patients support system and raise an alarm in realtime in case of emergencies [7].

- Real time monitoring of location of critical equipment in the hospital.
- Monitoring the location of Doctors, hospital staff, patients or their family members so that they can be reached out in critical situations.
- Real time data of patients vitals [21].

In this system we plan to monitor the state of stationary objects as well as people in motion inside a closed environment. Hence we use the mobility and non-mobility results from our indoor experiments to study the precautions we need to take while designing a healthcare monitoring system.

- Quality of Service : The Quality of Service of a LPWAN application cannot be compromised as it can be a matter of life and death for the patient. It can be seen from our results that both the end to end delay and packet loss rates increase as mobility speed increases.
- Location of gateway : Since the location of gateway is fixed while a sensor attached to a patient might move across different rooms or also different buildings, it is very important to consider the effect of walls in an indoor environment as we can conclude from our results that under mobility conditions LPWAN shows degraded performance in an indoor environment.
- Data size : In cases where a sensor is tracking multiple information about the patient, the data packet size being send increases. It can be seen from our results that as the data packet size increases, it does increases the end to end delay thus affecting the quality of service of the network.
- Varying movement speed : A patient being tracked can be moving at different speeds when he is just taking a walk or being rushed to a surgery. In both cases the network performance will be different as at higher speeds the network performance is affected drastically.

7.3 LPWAN FOR UAVS

Deploying an LPWAN network using UAVs is an interesting topic which can help serve various application areas. UAVs offer an inherent attribute of being able to vary its altitude and move in a three dimensional space compared to other land moving vehicles. A LPWAN network deployed using UAV can serve carious applications like:

- Search and rescue.
- Surveillance of area which might inaccessible to man.
- Use of UAVs to track weather conditions like storm or chasing a tornado to track its path.
- UAVs can also serve as an aerial base station extending the range of LPWAN network.

Even with such promising use cases of deploying an LPWAN network using UAVs, there are technical challenges that need to be addressed:

- Air to Ground communication : It is known that the communication medium used for wireless signal propagation does have an effect on network performance. It is also know that air to ground communication is more susceptible to blockage. As we can see from our results that concrete structures have an effect on LPWAN communication, it is important to consider the effect of same on air to ground communication [35].
- Deployment in 3-D space : Since UAVs are able to adjust their height along with their linear velocity, it adds an extra degree of freedom to its motion. A LPWAN network deployed using UAVs needs to be done while considering the effect of altitude along with velocity in 3D space as our results show that mobility does have a huge impact on network performance in 2D space [35].

7.4 GENERAL GUIDELINES

Some of the general guidelines to improve network performance under mobility conditions are:

- Spreading Factor : Use higher spreading factor wherever possible. A higher spreading factor helps to improve communication range [10].
- Gateway Positioning : In outdoor environment, placing a gateway as high as possible helps to decrease network interference from its surroundings.
- Data Packet design : It is very important to only transmit the data that is needed and leave the junk data out as our results show that the size of the data packet has a big impact on end to end delay and packet loss rate in case of mobility.
- Antenna : Using a more powerful antenna and also adjusting it at a specific angle helps to increase network performance and range. It was seen that the range of LL RXR 27 module increased when we replaces the trace antenna with ANT-916 antenna tuned for 915 MHz with a maximum gain of 1.9 dBi or less. Adjusting antenna at certain angle also helps to improve the network performance

8 CONCLUSIONS AND FUTURE WORK

8.1 CONCLUSION

Starting with discussion on basic working of LPWAN standards and pros and cons of each standard, we described LoRaWAN in more details as we used the LPWAN standard for our experiments. We then surveyed existing experimental studies on the effect of mobility for LPWAN, which helped us set our thesis objectives. We then presented the implementation details and explained our experimental setup. While doing so we provided insights into the working of communication code which acts as a guideline for future research. The last step was to conduct experiments by subjecting the end node to human as well as auto mobility. We recorded the packet loss rate and end to end delay for the network by varying the mobility speed, distance between the end node and gateway, and by varying the data packet size.

The experimental results allowed us to identify the issues faced by LPWAN network when subjected to mobility conditions. In case of the indoor environment, the average end to end delay increased as we increased the packet size and the distance from the gateway. The average end to end delay for mobile node increased as the distance between the end node and gateway increased. The packet loss rate was low when the node is stationary. However, it dramatically increased as the distance and speed of the end node increased. We observed that LPWAN shows promising results when the end device is stationary. However, our results further showed that LPWAN is easily impacted even with minor mobility like human mobility. The impact of mobility was significantly escalated as the distance between the gateway and end device was increased. The impact of mobility increased as the end node speed was increased. Our results also revealed that impact of mobility was greater for an indoor environment than an outdoor environment.

We expect that the results and guidelines discussed in this research will be useful for students, engineers and researchers who are currently working on or interested

deploying a LPWAN network in mobile environment or for those who are working to developing mobility aware LPWAN standards.

8.2 FUTURE WORK

There are a number of topics related to the study done in this thesis which can be a part of future work in the direction of further understanding the performance of LPWAN in mobile IoT. Some of them are:

- In this thesis, we studied the effect of two dimensional motion of an end node. However, studying the effect of three dimensional motion will help us understand how LPWAN technologies would perform when IoT devices are incorporated onto devices like small unmanned aerial vehicles.
- It will be beneficial to study how LPWAN performs underwater where it can be used to study and monitor underwater activities of plants, animals and water pollution.
- In this thesis, experimental study was conducted using the LoRaWAN standard. It would be beneficial to conduct the same using other LPWAN technologies to better understand the mobility effect.

REFERENCES

- [1] I. 18000-7, “Information technology – radio frequency identification for item management – part 7: Parameters for active air interface communications at 433 mhz,” Tech. Rep., 2014.
- [2] (Apr. 29, 2018). 3gpp low power wide area technologies - gsma white paper, [Online]. Available: <https://www.gsma.com/iot/wp-content/uploads/2016/10/3GPP-Low-Power-Wide-Area-Technologies-GSMA-White-Paper.pdf>.
- [3] T. Adame, A. Bel, B. Bellalta, J. Barcelo, and M. Oliver, “Ieee 802.11ah: The wifi approach for m2m communications,” *IEEE Wireless Communications*, vol. 21, no. 6, 2014.
- [4] F. Adelantado, X. Vilajosana, P. Tuset-Peiro, B. Martinez, and J. Melia, “Understanding the limits of lorawan,” *arXiv preprint arXiv:1607.08011*, 2016.
- [5] A. Adhikary, X. Lin, and Y. P. Wang, “Performance evaluation of nb-iot coverage,” in *2016 IEEE 84th Vehicular Technology Conference (VTC-Fall)*, IEEE, 2016.
- [6] A. Augustin, J. Yi, T. Clausen, and W. M. Townsley, “A study of lora: Long range & low power networks for the internet of things,” *Sensors*, vol. 16, no. 9, 2016. DOI: 10.3390/s16091466.
- [7] S. Baker, W. Xiang, and M. Atkinson, “Internet of things for smart healthcare: Technologies, challenges, and opportunities,” *IEEE Access*, vol. 5, pp. 26 521–26 544, 2017.
- [8] D. Carvalho, A. Depari, P. Ferrari, A. Flammini, S. Rinaldi, and E. Sisinni, “On the feasibility of mobile sensing and tracking applications based on lpwan,” in *2018 IEEE Sensors Applications Symposium (SAS)*, Mar. 2018, pp. 1–6.
- [9] J. Casselgren, M. Sjodahl, and J. P. LeBlanc, “Model-based winter road classification,” *International Journal of Vehicle Systems Modelling and Testing*, vol. 7, no. 3, 2012.
- [10] M. Cattani, C. A. Boano, and K. Romer, “An experimental evaluation of the reliability of lora long-range low-power wireless communication,” *Journal of Sensor and Actuator Networks*, vol. 6, no. 2, p. 7, 2017, ISSN: 2224-2708. DOI: 10.3390/jsan6020007.
- [11] M. Centenaro, L. Vangelista, A. Zanella, and M. Zorzi, “Long-range communications in unlicensed bands: The rising stars in the iot and smart city scenarios,” *IEEE Wireless Communications*, vol. 23, 2016.

- [12] S. Chen, H. Xu, B. H. D. Liu, and H. Wang, "A vision of iot: Applications, challenges, and opportunities with china perspective," *IEEE Internet of Things Journal*, vol. 1, no. 4, 2014.
- [13] J. W. Chuah, "The internet of things: An overview and new perspectives in systems design," in *2014 International Symposium on Integrated Circuits (ISIC)*, IEEE, 2014, pp. 216–219.
- [14] C. Civelek, "Low power wide area network (lpwan) and internet of things adaptation in agricultural machinery," vol. 4, pp. 18–23, Jan. 2017.
- [15] T. ElBatt, C. Saraydar, M. Ames, and T. Talty, "Potential for intra-vehicle wireless automotive sensor networks," in *2006 IEEE Sarnoff Symposium*, IEEE, 2006, pp. 1–4.
- [16] (Feb. 4, 2017). Ericsson white paper, cellular networks for massive iot, [Online]. Available: https://www.ericsson.com/res/docs/whitepapers/wp_iot.pdf.
- [17] (Jul. 20, 2016). Growing industry applications of lpwan technologies, [Online]. Available: http://rfdesignuk.com/uploads/9/4/6/0/94609530/murata_lpwan_study.pdf.
- [18] (Feb. 3, 2018). Hewlett packard digital modulation in communications systems an introduction, [Online]. Available: <http://cp.literature.agilent.com/litweb/pdf/5965-7160E.pdf>.
- [19] D. B. Hoang and L. Chen, "Mobile cloud for assistive healthcare (mocash)," in *2010 IEEE Asia-Pacific Services Computing Conference*, IEEE, 2010, pp. 325–332.
- [20] (Feb. 4, 2017). Ingenu rpma, [Online]. Available: <http://www.ingenu.com>.
- [21] (Jul. 20, 2016). Iot in healthcare, benefits and challenges, [Online]. Available: <https://www.peerbits.com/blog/internet-of-things-healthcare-applications-benefits-and-challenges.html>.
- [22] O. Iova, A. L. Murphy, G. P. Picco, L. Ghio, D. Molteni, F. Ossi, and F. Cagnacci, "Lora from the city to the mountains: Exploration of hardware and environmental factors," in *Proceedings of the 2017 International Conference on Embedded Wireless Systems and Networks*, USA: Junction Publishing, 2017, pp. 317–322.
- [23] D. Ismail, M. Rahman, and A. Saifullah, "Low-power wide-area networks: Opportunities, challenges, and directions," in *Proceedings of the Workshop Program of the 19th International Conference on Distributed Computing and Networking*, ser. Workshops ICDCN '18, Varanasi, India, 2018, 8:1–8:6, ISBN: 978-1-4503-6397-6. DOI: 10.1145/3170521.3170529.

- [24] S. Karnouskos, A. W. Colombo, T. Bangemann, K. Manninen, R. Camp, M. Tilly, P. Stluka, F. Jammes, J. Delsing, and J. Eliasson, "A soa-based architecture for empowering future collaborative cloud-based industrial automation," in *IECON 2012 - 38th Annual Conference on IEEE Industrial Electronics Society*, IEEE, 2012, pp. 5766–5772.
- [25] E. Khorov, A. Lyakhov, A. Kritiv, and A. Guschin, "A survey on ieee 802.11 ah: An enabling networking technology for smart cities," *Computer Communications*, vol. 58, 2015.
- [26] J. Laveyne, G. V. Eetvelde, and L. Vandeveldel, "Application of lorawan for smart metering: An experimental verification," eng, in *Proceedings of Energy for Tomorrow*, Venice, Italy, 2017, ISBN: 978-3-9818275-5-2.
- [27] L. Lingling, R. Jiuchun, and Z. Quian, "On the application of lora lpwan technology in sailing monitoring system," in *2017 13th Annual Conference on Wireless On-demand Network Systems and Services (WONS)*, IEEE, 2017, pp. 77–80.
- [28] (Jan. 15, 2017). Lora alliance, a technical overview of lora and lorawan, [Online]. Available: <https://lora-alliance.org/resource-hub>.
- [29] (Mar. 6, 2018). Lpwan standard comparison, [Online]. Available: <https://cms.edn.com/ContentEETimes/Documents/EDN/LP%20WAN%20Comparison%20Table%20final.pdf>.
- [30] (Dec. 1, 2016). Lpwan technology decisions, [Online]. Available: <http://www.weightless.org/membership/lpwan-technology-features-document-update>.
- [31] (Mar. 4, 2018). Lpwan technology decisions, [Online]. Available: <https://www.semtech.com/>.
- [32] G. Margelis, R. Piechocki, D. Kaleshi, and P. Thomas, "Low throughput networks for the iot: Lessons learned from industrial implementations," in *2015 IEEE 2nd World Forum on Internet of Things (WF-IoT)*, IEEE, 2015, pp. 181–186.
- [33] (Jan. 10, 2018). Microchip lorawan class presentation, [Online]. Available: <http://www.spincraft.com/hackers/wp-content/uploads/2017/01/LoRaWAN-101-Class-v2-MARCOM-1.pdf>.
- [34] K. Mikhaylov, J. Petajajarvi, and J. Janhunen, "On lorawan scalability: Empirical evaluation of susceptibility to inter-network interference," *arXiv preprint arXiv:1704.04257*, 2017.
- [35] M. Mozaffari, W. Saad, M. Bennis, Y. Nam, and M. Debbah, "A tutorial on uavs for wireless networks: Applications, challenges, and open problems," *CoRR*, vol. abs/1803.00680, 2018.

- [36] M. Mozaffari, M. B. W. Saad, and M. Debbah, “Mobile internet of things: Can uavs provide an energy-efficient mobile architecture?” *arXiv preprint arXiv:1607.02766*, 2016.
- [37] T. Myers, D. Werner, K. Sinsua, J. Wilson, S. Reuland, P. Singler, and M. Huovila, “Light monitoring system using a random phase multiple access system,” pat. US Patent 8,477,830, 2008. [Online]. Available: <https://patents.google.com/patent/US8477830>.
- [38] P. Neumann, J. Montavont, and T. Noel, “Indoor deployment of low-power wide area networks (lpwan): A lorawan case study,” in *2016 IEEE 12th International Conference on Wireless and Mobile Computing, Networking and Communications (WiMob)*, IEEE, 2016, pp. 1–8.
- [39] (Jan. 29, 2017). Nfc, near field communication, [Online]. Available: <http://www.nearfieldcommunication.org>.
- [40] K. E. Nolan, W. Guibene, and M. Y. Kelly, “An evaluation of low power wide area network technologies for the internet of things,” in *2016 International Wireless Communications and Mobile Computing Conference (IWCMC)*, IEEE, 2016, pp. 439–444.
- [41] (Dec. 1, 2016). Overview of lpwan technology, [Online]. Available: <http://www.indigoo.com/dox/itdp/12MobileWireless/LPWAN.pdf>.
- [42] A. Pantelopoulos and N. G. Bourbakis, “A survey on wearable sensor-based systems for health monitoring and prognosis,” *IEEE Transactions on Systems, Man, and Cybernetics, Part C (Applications and Reviews)*, vol. 40, no. 1, 2010.
- [43] M. Park, “Ieee 802.11ah: Sub-1-ghz license-exempt operation for the internet of things,” vol. 53, pp. 145–151, Sep. 2015.
- [44] S. K. Park, K. Hwang, H. S. Kim, and B. S. Shim, *Challenges and Experiment with LoRaWAN*.
- [45] D. Patel and M. Won, “Experimental study on low power wide area networks (lpwan) for mobile internet of things,” *2017 IEEE 85th Vehicular Technology Conference (VTC Spring)*, pp. 1–5, 2017.
- [46] J. Petajajarvi, K. Mikhaylov, M. Hamalainen, and J. Iinatti, “Evaluation of lora lpwan technology for remote health and wellbeing monitoring,” in *2016 10th International Symposium on Medical Information and Communication Technology (ISMICT)*, IEEE, 2016, pp. 1–5.
- [47] J. Petajajarvi, K. Mikhaylov, M. Pettissalo, J. Janhunen, and J. Iinatti, “Performance of a low-power wide-area network based on lora technology: Doppler robustness, scalability, and coverage,” vol. Vol. 13, pp. 1–16, Mar. 2017.

- [48] T. Petric, M. Goessens, L. Nuaymi, A. Pelov, and L. Toutain, "Measurements, performance and analysis of lora fabian, a real-world implementation of lpwan," in *2016 IEEE 27th Annual International Symposium on Personal, Indoor and Mobile Radio Communications (PIMRC)*, IEEE, 2016.
- [49] U. Raza, P. Kulkarni, and M. Sooriyabandara, "Low power wide area networks: An overview," *IEEE Communications Surveys Tutorials*, vol. 19, 2017.
- [50] B. Reynders, W. Meert, and S. Pollin, "Range and coexistence analysis of long range unlicensed communication," in *2016 23rd International Conference on Telecommunications (ICT)*, IEEE, 2016, pp. 1–6.
- [51] B. Reynders and S. Pollin, "Chirp spread spectrum as a modulation technique for long range communication," in *2016 Symposium on Communications and Vehicular Technologies (SCVT)*, IEEE, 2016, pp. 1–5.
- [52] D. Rosario, Z. Zhao, A. Santos, T. Braun, and E. Cerqueira, "A beaconless opportunistic routing based on a cross-layer approach for efficient video dissemination in mobile multimedia iot applications," *IEEE Internet of Things Journal*, vol. 45, 2014.
- [53] (Apr. 23, 2018). Rpma: Technology for the internet of things, [Online]. Available: http://theinternetofthings.report/Resources/Whitepapers/4cbc5e5e-6ef8-4455-b8cd-f6e3888624cb_RPMA%20Technology.pdf.
- [54] (Feb. 3, 2018). Samtech, [Online]. Available: <https://www.samtech.com/>.
- [55] F. Sforza, "Communication system," pat. US Patent 8,406,275, 2013.
- [56] A. Shrestha and M. Won, "Deepwalking: Enabling smartphone-based walking speed estimation using deep learning," *arXiv preprint arXiv:1805.03368*, 2018.
- [57] (Feb. 4, 2018). Sigfox, [Online]. Available: <https://www.sigfox.com/en>.
- [58] L. Skorin-Kapov, K. Pripuzic, M. Marjanovic, A. Antonic, and I. P. Zarko, "Energy efficient and quality-driven continuous sensor management for mobile iot applications," in *10th IEEE International Conference on Collaborative Computing: Networking, Applications and Worksharing*, IEEE, 2014, 397–406.
- [59] N. Sornin, M. Luis, T. Eirich, T. Kramp, and O. Hersent, *Lorawan specification*, version V1.0.2. 2016.
- [60] J. A. Stankovic, "Research directions for the internet of things," *IEEE Internet of Things Journal*, vol. 1, no. 1, 2014.
- [61] (May 5, 2018). Telensa, [Online]. Available: <https://www.telensa.com/unb-wireless/>.

- [62] T. T. Vazquez, S. B. Munoz, B. Bellalta, and A. Bel, "Hare: Supporting efficient uplink multi-hop communications in self-organizing lpwans," *Sensors*, vol. 18, no. 1, 2018, ISSN: 1424-8220. DOI: 10.3390/s18010115. [Online]. Available: <http://www.mdpi.com/1424-8220/18/1/115>.
- [63] H. Wang, H. Sui, X. Liao, and J. Li, "Comparative analysis of the application of different low power wide area network technologies in power grid," *IOP Conference Series: Materials Science and Engineering*, vol. 322, no. 7, p. 072 030, 2018. [Online]. Available: <http://stacks.iop.org/1757-899X/322/i=7/a=072030>.
- [64] Y. P. Wang, X. Lin, A. Adhikary, A. Grovlen, Y. Sui, Y. Blankenship, J. Bergman, and H. S. Razaghi, "A primer on 3gpp narrowband internet of things (nb-iot)," vol. 55, Jun. 2016.
- [65] (Nov. 23, 2016). Wearabletech, [Online]. Available: <http://www.wearabletechnology-news.com/news/2016/apr/22/idtechexpredicts-three-billion-wearable-sensors-2025>.
- [66] (Apr. 3, 2018). Weightless sig, [Online]. Available: <http://www.weightless.org/>.
- [67] M. Weyn, G. Ergeerts, R. Berkvens, B. Wojciechowski, and Y. Tabokov, "Dash7 alliance protocol 1.0: Low-power, mid-range sensor and actuator communication," in *2015 IEEE Conference on Standards for Communications and Networking (CSCN)*, IEEE, 2015.
- [68] A. Wixted, P. Kinnaird, A. Tait, A. Ahmadinia, and N. Strachan, "Evaluation of lora and lorawan for wireless sensor networks," in *2016 IEEE Sensors*, IEEE, 2016, pp. 1–3.
- [69] M. Won, "A review on v2v communication for traffic jam management," *Vehicle-to-Vehicle and Vehicle-to-Infrastructure Communications: A Technical Approach*, p. 1, 2018.
- [70] M. Won, H. Alsaadan, and Y. Eun, "Adaptive audio classification for smartphone in noisy car environment," in *Proceedings of the 2017 ACM on Multimedia Conference*, ACM, 2017, pp. 1672–1679.
- [71] M. Won, A. Mishra, and S. H. Son, "Hybridbaro: Mining driving routes using barometer sensor of smartphone," *IEEE Sensors Journal*, vol. 17, no. 19, pp. 6397–6408, 2017.
- [72] M. Won, T. Park, and S. H. Son, "Toward mitigating phantom jam using vehicle-to-vehicle communication," *IEEE transactions on intelligent transportation systems*, vol. 18, no. 5, pp. 1313–1324, 2017.
- [73] M. Won, A. Shrestha, and Y. Eun, "Enabling wifi p2p-based pedestrian safety app," *arXiv preprint arXiv:1805.00442*, 2018.

- [74] M. Yamada, Y. Hara, K. Kamio, and S. Hara, "Packet communications with slotted aloha in a mobile cellular system," *Vehicular Technology Conference, 2001. VTC 2001 Fall. IEEE VTS 54th*, 2011.
- [75] S. S. Yau and A. B. Buduru, "Intelligent planning for developing mobile iot applications using cloud systems," in *2014 IEEE International Conference on Mobile Services*, IEEE, 2014, pp. 55–62.