



University of Pennsylvania
ScholarlyCommons

Theses (Historic Preservation)

Graduate Program in Historic Preservation

2009

An Investigation of Quantifying and Monitoring Stone Surface Deterioration Using Three Dimensional Laser Scanning

Jessica Kottke

University of Pennsylvania, kottke@design.upenn.edu

Follow this and additional works at: http://repository.upenn.edu/hp_theses

Kottke, Jessica, "An Investigation of Quantifying and Monitoring Stone Surface Deterioration Using Three Dimensional Laser Scanning" (2009). *Theses (Historic Preservation)*. 128.
http://repository.upenn.edu/hp_theses/128

A Thesis in Historic Preservation Presented to the Faculties of the University of Pennsylvania in Partial Fulfillment of the Requirements of the Degree of Master of Science in Historic Preservation 2009

This paper is posted at ScholarlyCommons. http://repository.upenn.edu/hp_theses/128
For more information, please contact libraryrepository@pobox.upenn.edu.

An Investigation of Quantifying and Monitoring Stone Surface Deterioration Using Three Dimensional Laser Scanning

Abstract

Three dimensional laser scanning is considered to be the next generation of documentation methods, however the cost of these technologies remains extremely high and there are both known and unknown limitations of their application. This thesis, therefore, investigates the strengths and weaknesses of 3D laser scanning, identifies potential sources of error, investigates potential uses for the data while focusing on its use for quantifying and monitoring stone surface deterioration, and determines the success of resulting 3D models for communicating conditions information. Additionally, the ambiguity in existing literature regarding success of applications of 3D laser scanning for meeting project objectives, including cost - benefit analyses, indicates this topic warrants exploration. In order to perform this analysis four topics of investigation are followed: 1) Identification of tools for recording and monitoring surface deterioration of stone, which will provided a basis for comparing laser scanning techniques. 2) Identification of recording standards and objectives for heritage sites, which laser scanning methods must satisfy. 3) Identification of stone deterioration types and surface appearance, specifically marble, which laser scanning data will need to represent for conditions analysis. 4) Undertaking a test case study: three dimensional laser scanning of the stone lions at the Merchants' Exchange Building, Philadelphia, PA, to determine whether the data can be used for conditions surveying and monitoring of surface deterioration on the lions. The coalescence of these topics will provide a datum on which to begin investigating whether or not 3D laser scanning is an appropriate and practicable tool for enabling informed decision making for conservation and heritage management.

Comments

A Thesis in Historic Preservation Presented to the Faculties of the University of Pennsylvania in Partial Fulfillment of the Requirements of the Degree of Master of Science in Historic Preservation 2009

**An Investigation of Quantifying and Monitoring Stone Surface
Deterioration Using Three Dimensional Laser Scanning**

Jessica Kottke

A Thesis

in

Historic Preservation

Presented to the Faculties of the University of Pennsylvania in
Partial Fulfillment of the Requirements of the Degree of

Master of Science in Historic Preservation

2009

Advisor

John Hinchman

Lecturer, Graduate Program in
Historic Preservation

Advisor

Frank G. Matero

Program Chair
Professor of Architecture, Graduate
Program in Historic Preservation

Acknowledgements

Immense Thanks To The Following People for their Advice and Expertise

John Hinchman, University of Pennsylvania

Frank Matero, University of Pennsylvania

Michael Henry, University of Pennsylvania

Scott White, University of Pennsylvania

R. Larry Holtgreive, 3D Consultants, LLC.

George Allport & Keystone Precision Instruments

Roy Ingraffia, Milner+Carr Conservation, LLC.

Scott Diaz, KubitUSA

and first and foremost, Ian Wallace-Hoyt

Contents

Acknowledgements ii

Table of Contents iii

List of Images vi

List of Tables vii

Definitions 1

Introduction 5

Chapter 1) Stone Deterioration: Types, Appearances and Classification Systems Used for Characterizing and Monitoring Topographies 7

Introduction 7

Stone Deterioration 7

Loss of substrate material 8

Discoloration/ Deposit 9

Detachment 10

Fissures/ Deformations 11

Previous Interventions 12

Chapter 2) Tools for Recording, Quantifying and Monitoring Stone Surface Deterioration 14

Introduction 14

Profilometry 16

The Technique and Equipment 16

Applications 18

Photogrammetry 19

History 20

The Technique and Equipment 20

Applications 22

Microerosion Meter (MEM) 24

The Technique and Equipment 24

Applications 26

3D Laser Scanners 27

Basics 27

- The Technique and Equipment 28
- Triangulation scanners 31
- Terrestrial Time-of-flight (or Pulse) Scanners 32
- Phase-comparison scanners 32
- Airborne laser scanning 32
- Applications 35

Erosion Pins 37

- The Technique and Equipment 37
- Applications 38

Moulds 38

Graphic Condition Surveys 40

Summary 41

Chapter 3) Quantifying and Monitoring Standards and Objectives for Heritage Sites 42

Recording 42

- Inception and Development within the Literature 42
- Guiding Standards and Objectives 47
- Appropriate Scope 48
- Site Accessibility, Form and Complexity 49
- Time Frame 51
- Risk to Object 51
- Cost and Cost Benefit Analysis 52

Monitoring 53

- Criteria for Creating a Monitoring Program and Selecting Appropriate Tools 53
- Sampling Resolution 54
- Site Accessibility, Form and Complexity 55
- Timeframe 55
- Measurement Repeatability 56
- Error and Accuracy 57
- Visual Representation of Data 59
- Cost 60
- Summary of Standards and Objectives for 3D Laser Scanning 62

Chapter 4) Test Case 65

Condition Survey 65

 Data Collection 67

 Lessons Learned 70

 Post-Processing: Workflow 71

 Post-Processing: Debunking Presumptions 75

Monitoring 84

Test Case Summary 88

Final Conclusions 89

Bibliography 92

Appendices 97

 Appendix A: The Lions at the Merchants Exchange 98

 Appendix B: Evaluation of 3D Laser Scanning and Point Cloud
 Data 105

 Appendix C: List of Vendors and Software Companies 112

Index 113

List of Images

Fig. 1:	Rotary Laser Profilometer	17
Fig. 2:	The Microerosion Meter	25
Fig. 3:	Triangulation 3D Laser Scanner Operation	33
Fig. 4:	Laser Shape Projections for Triangulation 3D Scanners	34
Fig. 5:	Time-of-flight 3D Laser Scanner Operation	34
Fig. 6:	Phase Comparison 3D Scanner	35
Fig. 7:	Modeling the Lions: Workflow	68
Fig. 8:	Draping Photos	76
Fig. 9:	Shadow Color Captured as True Color	77
Fig. 10:	Comparison between a Hand Drawing and a Point Cloud	80

List of Tables

Table 1:	Scanner Types and Resolutions	30
Table 2:	Sources of Error in 3D Laser Scanning and Potential Effects on Test Case	106
Table 3:	Applications of 3D Laser Scanning in Heritage Preservation	38
Table 4:	Specifications for the Trimble GX 3D Scanner	66
Table 5:	Evaluated Software for Point Cloud Editing, Meshing & Modeling	109
Table 6:	Assessment of Required Intervals between Scans as a Function of Recession Rates and Point Cloud Resolutions	86

Definitions

Analog (analogue)- Measuring or representing data by means of one or more physical properties that can express any value along a continuous scale. For example, the position of the hands of a clock is an analog representation of time.¹

Base-line data- a) a line serving as a basis, as for measurement, calculation, or location, b) a measurement, calculation, or location used as a basis for comparison.²

Beam divergence- widening of the laser beam according to the length of the distance it travels.³

Conservation Cycle- the process of conservation that moves through 1) Evaluation of the site or objects significance/ authenticity/ value, 2) Diagnosis or the understanding and assessment of its condition, 3) Intervention, 4) Monitoring and maintenance of the effect of the intervention and site or object's condition, and 5) Re-evaluation where the cycle begins again.⁴

Cultural Heritage- "monuments, groups of buildings and sites of heritage value, constituting the historic or built environment."⁵

Dumpy level- an optical instrument that is used in site surveying to establish the levels of the ground or surface topography using a horizontal line of site. It can also measure distances and take horizontal bearings.⁶ This tool is not typically

1 *The American Heritage Science Dictionary*. Houghton Mifflin Company, 2005, <http://www.thefreedictionary.com/analog>.

2 *The American Heritage Science Dictionary*, 2005, <http://www.thefreedictionary.com/baseline+data>

3 José Luis Lerma García, Bjorn Van Genechten, Erwin Heine, and Mario Santana Quintero, ed., *Theory and Practice on Terrestrial Laser Scanning Training Material Based on Practical Applications, Version 4*. (Valencia, Spain: Universidad Politécnica de Valencia, June 2008), 33.

4 Rand Eppich, Francois LeBlanc, English Heritage Technical Survey Archaeology, Divay Gupa, Peter Waldhausl, Robin Letellier, José Luis Lerma, John Hurd, *Documentation for Conservation: A Manual for Teaching Metric Survey Skills* (CIPA- RecorDIM, 2007), 5.

5 *Principles for the Recording of Monuments, Groups of Buildings and Sites* (ratified by the 11th ICOMOS General Assembly, Sophia, Bulgaria, October, 1996), http://www.international.icomos.org/charters/recording_e.htm.

6 Peter Leach, *The Surveying of Archaeological Sites* (London: Institute of Archaeology Publications, 1988), 25.

used for contemporary survey practice.

Error- the difference between the measured value and the “true value” of the thing being measured.⁷

Geometric Modeling (also called Computer-aided geometric design or CAGD)- Constructing and representing either 2D or 3D surfaces, curves and volumes in space.

Geo-referencing- process of transforming an object described in a local coordinate system into a global coordinate system.⁸

Heritage information- “the activity and products of recording, documenting and managing the information of cultural heritage places.”⁹

Metric Survey- the application of precise, reliable and repeatable methods of measurement for heritage documentation.¹⁰

Mixed Edge Problem- When a laser beam hits an edge of an object and the beam is split in two. One part of the beam reflects on the closer surfaces while the other part travels further to hit a back surface. Two different laser pulses return to the scanner and the point’s coordinates will be calculated based on an average of both return signals. Thus the point is incorrectly placed in space and the result is noise just behind the edge of the object. This problem is greatest in high resolution scans.¹¹

Monitoring- the disciplined and consistent observation and recordation of a selected condition or attribute, using qualitative and/or quantitative measures, over a period of time, to generate useful information or data for analysis and for presentation, and documented as to methodology and results.¹²

7 Stephanie Bell, “A Beginner’s Guide to Uncertainty of Measurement,” in *Measurement Good Practice Guide No. 11 (Issue 2)*, (March 2001): 2.

8 García, et al. ed. *Theory and Practice on Terrestrial Laser Scanning*, 215.

9 Robin Letellier, *Recording Documentation and Information Management for the Conservation of Heritage Places: Guiding Principles* (Los Angeles: J. Paul Getty Trust and The Getty Conservation Institute, 2007), vii.

10 Eppich et al., *Documentation for Conservation*, 4.

11 García, et al. ed. *Theory and Practice on Terrestrial Laser Scanning*, 34.

12 Michael C. Henry, *Technical Note: Monitoring, Interpretation and Use of Data* (Los Angeles: J. Paul Getty Trust, 2003): 1.

Point density- in a 3D point cloud, the number of points per unit as a function of the distance between each point. This is often called Resolution.

Random error- error that occurs selectively and for varying reasons during each measurement. The outcome causes different results for repeated measurements.

Resolution- the distance between two measurements. In 3D laser scanning, this is the distance between two points of the point cloud.

Rate of Decay - amount of loss/ time

Recession Rate- amount of loss from recession/ time

Reconnaissance- the process of preliminary inspection.¹³

Risk assessment- the process where hazards are identified, analyzed or evaluated for risks associated with those hazards, and an appropriate way to eliminate, control or mitigate the hazard is determined.¹⁴

Recording- “the capture of information which describes the physical configuration, condition and use of monuments, groups of buildings and sites, at points in time, and is an essential part of the conservation process.”¹⁵

Scanning station- the scanner at a recorded location during a scan session.

Spot Size- the footprint of the laser beam on the subject. Specifications for laser scanners will describe the spot size according to one of two very different expressions: the Gaussian diameter or the full-width half-height (FWHH) diameter. A beam’s maximum intensity is at the center of the beam and the Gaussian diameter definition is much more conservative than the FWHH definition, which results in a smaller beam diameter. Smaller spot sizes are more desirable because they are less prone to causing mixed-edge and surface

13 *Understanding the Archaeology of Landscapes: A Guide to Good Recording Practice* (English Heritage, 2007), 6.

14 García, et al. ed. *Theory and Practice on Terrestrial Laser Scanning*, 13.

15 *Principles for the Recording of Monuments, Groups of Buildings and Sites* (ratified by the 11th ICOMOS General Assembly, Sophia, Bulgaria, October, 1996), http://www.international.icomos.org/charters/recording_e.htm.

curvature effects. They are also better able to measure smaller and/or recessed features.¹⁶

Systematic error- error that occurs uniformly and for the same reasons throughout the measuring process. Results will deviate uniformly from the “true value” and often corrective formulas can be applied to all measurement results. Sometimes, however, this systematic errors are not detected by the operator and are therefore overlooked in the final analysis.

Texturizing- digital industry term indicating the treatment of a surface with a given color or texture.

Theodolite- an optical instrument that is used in site surveying to establish the levels of the ground or surface topography. It provides the same information as a dumpy level but is considered more accurate and can take readings above and below the instrument, in other words, the range of its collimation is greater.¹⁷

16 Geoff Jacobs, “3D Scanning: Understanding Spot Size for Laser Scanning,” *Professional Surveyor Magazine*, (October 2006), <http://www.profsurv.com/magazine/article.aspx?i=1720>.

17 Leach, *The Surveying of Archaeological Sites*,31.

Introduction

Significant technological developments have been made within the past decade. The preservation field is challenged by industry and client pressures to be innovative and incorporate these new technologies into practice.

Three dimensional laser scanning is considered to be the next generation of documentation methods, however the cost of these technologies remains extremely high and there are both known and unknown limitations of their application. This thesis, therefore, investigates the strengths and weaknesses of 3D laser scanning, identifies potential sources of error, investigates potential uses for the data while focusing on its use for quantifying and monitoring stone surface deterioration, and determines the success of resulting 3D models for communicating conditions information. Additionally, the ambiguity in existing literature regarding success of applications of 3D laser scanning for meeting project objectives, including cost - benefit analyses, indicates this topic warrants exploration.

In order to perform this analysis four topics of investigation are followed:

- Identification of tools for recording and monitoring surface deterioration of stone, which will provided a basis for comparing laser scanning techniques.
- Identification of recording standards and objectives for heritage sites, which laser scanning methods must satisfy.
- Identification of stone deterioration types and surface appearance, specifically marble, which laser scanning data will need to represent for conditions analysis.
- Undertaking a test case study: three dimensional laser scanning of the stone lions at the Merchant's Exchange Building, Philadelphia, PA to determine whether the data can be used for conditions surveying and monitoring of surface deterioration on the lions.

The coalescence of these topics will provide a datum on which to begin investigating whether or not 3D laser scanning is an appropriate and practicable tool for enabling informed decision making for conservation and heritage management

Chapter 1) Stone Deterioration: Types, Appearances and Classification Systems Used for Characterizing and Monitoring Topographies

Introduction

In order to form an appropriate conservation treatment plan, initial steps require the conservator to 1) diagnosis the decay mechanisms through visual, microscopic, and chemical analysis and 2) monitor the progression of decay over time in an effort to determine its intensity and rate. This thesis evaluates only those methods used for monitoring and quantifying surface stone decay, which is one step in the entire conservation process. Each type of decay mechanism will have different morphologies, therefore, their visual characterization in the form of a conditions glossary is an effective tool for diagnosing decay phenomena.¹⁸

Stone Deterioration

A basic distinction between types of decay is whether they are additive or subtractive; the stone will either loose material as part of the decay mechanism or it will gain material as part of the decay mechanism. Fitzner, Heinrichs, and Kownatzki have a more specific classification scheme that defines decay according to *loss of stone material, discoloration/ deposit, detachment, fissures/ deformation, and previous interventions*, yet these can nevertheless be classified into additive and subtractive groups.¹⁹ While such classification methods are

18 It is important to emphasize that in order to achieve a more accurate diagnosis, additional methods of investigation, including chemical analysis or microscopy, should be performed. Because this thesis is investigating the ability to represent surface conditions using a 3D laser scanner, only topographical indicators of decay will be discussed.

19 B. Fitzner et al., "Weathering forms: classification and mapping." *Natursteinkonservierung in der Denkmalpflege* (Munich: Bayerisches Landesamt für Denkmalpflege, 1995), 40 – 88.

useful, the specific visual nature of each decay phenomena is dependent on the individual qualities of the stone, its use, and its provenance. Therefore there will be variations between the visual appearances of decay phenomena from stone to stone. The following discussion classifies deterioration conditions according research by ICOMOS-ISCS,²⁰ Fitzner et al.,²¹ and the University of Pennsylvania Architectural Conservation Laboratory (ACL).²² The Second Bank conditions glossary produced by the ACL is particularly useful because it is based on conditions exhibited by Pennsylvania Blue Marble, which is the material of the test case lions at the Merchants' Exchange (Appendix A).

Loss of substrate material

Decay forms in this category are characterized by the loss of material below the surface layer. While the symptoms are visible on the outer surface layer, their origin is subsurface. The following are subcategories which help to further define this form of deterioration:

- **Back weathering**- uniform material loss behind, but parallel to, the original stone surface, such as from loss of scales, crusts, or indefinable stone elements.
- **Relief**- selective loss of compact material causing morphological change of the stone's surface layer. This includes rounding or notching in sedimentary stones, alveolar weathering, loss of material according to the stone's structure, roughening, and pitting.
- **Break out**- selective or isolated loss of fragments or compact material on

20 *ICOMOS-ISCS: Illustrated Glossary on Stone Deterioration Patterns* (ICOMOS-ISCS, 2009).

21 Fitzner, "Weathering forms," 1995.

22 *Documentation and Conditions Survey of the Exterior Marble Masonry of the Second Bank of the United States, Philadelphia, PA* (Philadelphia: The University of Pennsylvania ACL, July 2004).

the surface of the stone. This can be due to human activities, structural strains, and natural causes such as earthquakes or biological growth.

- **Microkarst**- network of small interconnected millimeter to centimeter depressions, exhibiting patterns similar to hydrographic networks. Microkarst patterns are due to a partial and/or selective dissolution of calcareous stone surface exposed to water run-off.
- **Differential erosion**- surface weathering defined by a) large areas of coarse texture, b) localized loss greater than ¼ inch in depth (such as along foliation plans), or c) reduction of surface details (such as weathered edges).

Discoloration/ Deposit

This includes decay forms that cause a change to the stone color, to crusts, or to accretions along the stone surface. They are generally considered additive decay phenomena but can cause material loss and have a net subtractive result.

- **Discoloration**- either the coloration or bleaching of the surface material at a given intensity relative to the stone's original coloration.
- **Soiling**- adhesion of pollutants from the atmosphere, water, guano, or human activities. The intensity can be determined by the degree and strength of the soiling particulate.
- **Loose salt deposits**- decay caused by the recrystallization of solubilized salts which are either inherent in the stone material or introduced by environmental factors. Deposition can occur either on the stone surface through efflorescence, or in the pores and microstructure of the stone material through subflorescence. While the addition of crystallized salts can be considered decay from additive material, if subflorescence occurs, the result will be an overall loss of stone material.
- **Crusts**- they can generally be described according to their color (either light or dark) and morphology. A loose morphological categorization is divided into either superficial crusts, which exist on top of the stone surface, or integrated crusts that modify the stone surface. If crusts are

superficial, their intensity criteria will be determined by the amount of stone covered by crusts. However, if the crusts alter the surface, then the thickness of the crust will determine the amount of decay. While this is an additive form of decay, if the crusts modify the surface and the stone is destabilized, loss of stone material can occur.

- **Biological colonization**- an additive decay phenomenon where either microbiological colonization, such as thin biofilms, fungi and lichens, or colonization of higher plants, such as vines, occurs. While the actual decay mechanism is additive, hyphae and roots can cause the stone to break apart and material loss occurs.

Detachment

This group describes decay that causes stone material on the surface to detach from the bulk material and results in a loss of stone material.

- **Granular disintegration or sugaring**- the loss of material from the breakdown or cleaving of the stone's grains along grain-to-grain boundaries. The grain size determines the type and intensity of disintegration; detachment of the smallest grains forms powder along the stone surface, small grains forms sand, and larger grains forms grus. This can lead to other forms of detachment, such as crumbling and flaking.
- **Crumbling and splintering**- loss of material through the disintegration of larger grains or stone elements in the form of round crumbs or jagged splinters.
- **Flaking**- Detachment of small, thin stone elements along the profile of the stone; a smaller form of contour scaling. The larger quantity and frequency of smaller sized flakes and their individual thickness is the characteristic differentiating between contour scaling and flaking.
- **Contour scaling**- the detachment of larger, platy material parallel to the stone's surface. This type of decay is not solely dependent on the stone's structure but rather can result from the tooling of the stone's surface or from environmental factors. The two forms of scaling include single scales or stacks of multiple scales. The decay intensity can be determined by comparing the size and thickness of the scale or scale stacks relative to the original stone material.

- **Detachment of stone elements-** decay where the detachment of material is dependent on the stone structure and the materials' orientation within that structure. Exfoliation occurs when the structural elements are orientated parallel to the stone surface and the thickness of the detaching elements determine the severity of the weathering. Splitting occurs when the structural elements are oriented perpendicular to the stone surface and the frequency and width of the splits determine the intensity of the weathering.

- **Detachment of crusts with stone material-** as described above, crusts that change the stone surface can either physically weaken the stone's structure, leading to detachment, or they can alter the stone's chemical composition such that it becomes soluble or friable, also leading to detachment. The intensity of decay from crusts can be determined by knowing the thickness of the stone material that is interacting with the crust.

Fissures/ Deformations

This group describes deterioration phenomena through loss of material but more notably physical alterations of the stone.

- **Fissures-** individual fractures or intersecting fracture systems, where their presence and pattern formation is determined by structural characteristics such as bedding, foliation, or banding. Fissures can also be independent of the stone's structure and are caused by environmental or constructional causes, such as embedded metal elements.

- **Deformation-** weathering that causes bending or buckling of thin stone slabs due to plastic or stress related deformation. This is primarily attributed to the interaction of chemical, morphological and constructional characteristics of the stone element. Intensities can be determined by comparing the degree of deformation with what was likely the original form of the stone.

Previous Interventions

This group describes existing evidence of previous treatments or repairs.

- **Coatings**- the presence of a coating on a stone surface, generally an off-white, gray, or pale yellow color.
- **Filled cracks**- a mortar or resin based system for filling cracks.

This characterization system for determining visible weathering phenomena on stone surfaces is highly useful for *in situ* conditions mapping. However, more acute stone surface characterizations can also be defined according to their *roughness*, *waviness*, and *lay*.²³ Avdelidis et al. define *roughness* as the finest or shortest irregularities of a surface that are usually caused by production processes or material condition. *Waviness* is the more widely spaced or longer deviations of a surface and *lay* is the primary direction of the surface texture. While all three elements determine the overall surface texture of the stone, quantitative measurement methods typically only consider roughness. Methods for monitoring and quantifying surface deterioration at the micro-scale must have small enough resolutions to capture roughness as they exhibit characterizes of the stone at the granular level.

Knowledge of surface characteristics of stone can aid in the monitoring process by establishing a benchmark for the stone's surface conditions. Deviations from a "normal" topography will help to determine the rate and intensity of the weathering characteristics. Similarly, known recession rates for various geographies are also necessary for determining the minimum level of resolution necessary to capture change. Because stone topographies can

23 N.P. Avdelidis et al., "Surface roughness evaluation of marble by 3D laser profilometry and pulsed thermography," *NDT&E International* 37 (2007): 571.

be within micro ranges, such as roughness, or macro ranges, such as back weathering, each recording and monitoring tool must capture information at the appropriate scale. The next chapter will discuss the various tools that are used to characterize surfaces of stone objects and to quantify deterioration conditions.

Chapter 2) Tools for Recording, Quantifying and Monitoring Stone Surface Deterioration

Introduction

In order to determine the viability of three dimensional laser scanning as an appropriate tool for recording and monitoring stone surface conditions and deterioration phenomena, it must be compared to other tools used by conservators. Recording and monitoring tools are used to identify and characterize deterioration pathologies and to determine the sequence or rates of weathering in order to quantify the severity of that weathering. The ultimate purpose of such monitoring is to 1) determine whether intervention is necessary and if so 2) aid the conservator in formulating a treatment plan. A third purpose should be to evaluate the success and effects of treatments, but detecting surface characteristics has not been a widely used technique for this purpose.²⁴ As described in Chapter 1, the tools selected for the recording and monitoring program should be compatible with the type and suspected rate of deterioration being measured, the physical characteristics of the subject, and the general project parameters (such as time frame and cost).

The variety of available tools has increased as the demands of the conservation field have begun to encompass a more diverse and complex range of heritage subjects and sites. The capabilities of these tools began to expand as technological developments were made. Simultaneously, because technological solutions became more accessible and the demand from clients to use contemporary technologies and modes of visual representation increased, technology and digital media have become an integral constituent in

²⁴ C. A. Grissom, A. E. Charola, M. J. Wachowiak, "Measuring Surface Roughness on Stone: Back to Basics," *Studies in Conservation* 45, no. 2, (2000): 73.

contemporary recording and monitoring practices. In addition to client demand, many of these new tools are also preferred by the practitioner because they have the potential of being time saving and/ or more accurate.

Principle tools used for recording and monitoring stone surface conditions include 3D laser scanning, profilometry, photogrammetry, erosion pins, moulds, microerosion meters, and graphic condition surveys. These can loosely be divided into groups according to how they record information: tools that digitize measurement information, tools that require the operator to manually perform and log measurements, and tools that perform analog measurements. Similarly, they can be categorized according to how they interact with the subject: tools that capture information from which measurements are extracted (indirect measurement or remote-sensing devices) and tools that the operator uses to record measurements directly from the subject (direct measurements). A third categorization describes the affects they have on the subject: destructive methods (requiring interference or damage to the subject to perform measurements), micro-destructive methods (affecting the subject but not causing significant damage), and non-destructive methods (not requiring damage to the subject). These are not strict categorizations, for example some techniques, such as photogrammetry, can generate both digital and analogue information. Further more, many tools that previously recorded analog information now capture it digitally. Therefore, there are six primary ways to characterize a tool: digital or manual, direct or indirect, destructive or non-destructive. However, the underlying principles of these tools as applied to stone are that they must all undertake measurements of dimensional change (loss or expansion), surface characteristics (such as granularity), or surface conditions (weathering phenomena).

Profilometry

Profilometer- based tools capture the profile of an object and are frequently used to measure surface roughness. Laser-based systems can record information at resolutions up to 1 μ m, while contact profilometers usually achieve 20 μ m resolutions. The resolution is a function of the spot size of the laser beam or the radius of the stylus. In general this tool can be classified as *digital* (the information is converted into a digital format), *indirect* (it calculates measurements from the captured profile rather than directly from the object) and *non-destructive* (does not require damage to the subject).

The Technique and Equipment

There are various profile-creating tools, however common types are: laser triangulation profilometry, 3D laser optical profilometry, stylus profilometry, and confocal profilometry.

A form of laser profilometry is the 3D optical surface rotary profilometer, which uses a line-shaped laser beam and triangulation principles to capture 3D surface information, such as the overall shape and opened surface cracks (Fig. 1). The surface appearance of the object can be applied to the model if the device simultaneously captures images, usually with a CCD camera, corresponding to each profile.

When the laser is projected onto the object, it becomes deformed. The device calculates the geometrical dimensions of the object by measuring the deviations of the laser line from its reference position. The entire form of the object can be measured if it is placed on a rotary stage, which rotates the object at a known speed and allows the device to capture the profile in 360 degrees. The profile information is then obtained by extracting the center line of the line-

shaped laser beam from the corresponding CCD image.²⁵

Figure 1: Rotary Laser Profilometer

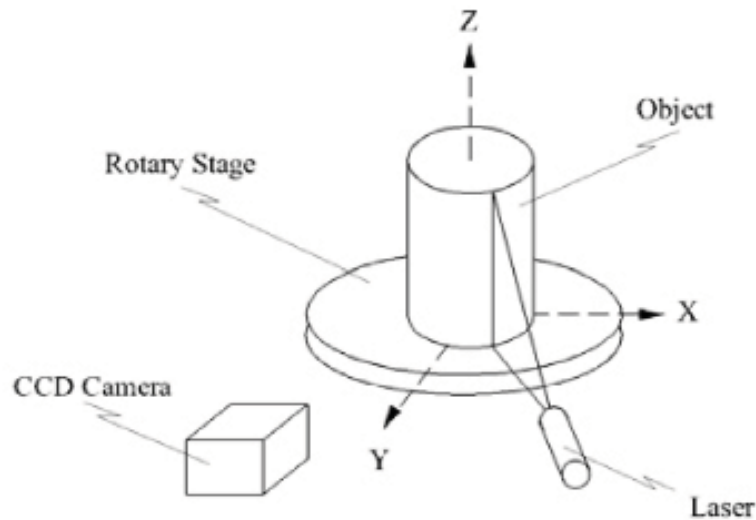

Source: Tmjillo-Schiaffino et al., "Three-dimensional Profilometry of Solid Objects in Rotation," (proceedings from *RIA/OPTILAS*, 2007), 924.

Loss of material can be determined by comparing the same line profile of different periods while changing conditions can be determined by comparing condition maps of different periods. To perform either type of comparison, it is essential to locate each data set within a universal coordinate system. This allows the data collection process to be repeatable, a requirement for monitoring as described in Chapter 3, and to be able to relocate the relevant location on the object. The tool cannot provide internal information for fine surface cracks because the laser beam or stylus cannot access it, nor can the tool provide subsurface information. Therefore, the technique is most successful

25 Seung-Kyu Park et al., "Laser Ultrasonic Inspection System with a 3D Surface Profilometry to Detect Surface Cracks," *Modern Physics Letters B* 22, no. 11 (2008): 1053.

when combined with other modes of analysis, such as ultrasonic inspection.²⁶ Additionally, corrective calculations, which are incorporated into the profile calculations, must be applied to account for the magnified image which is a result of the 45 degree viewing angle of the CCD camera.

Another profile-based tool used in conservation practices, especially in painting conservation, is white light confocal profilometry. This tool measures surface roughness at the micron and sub-micron scale. It uses the principals of confocal microscopy (where the focal point of the objective lens on the microscope is restricted by a screen with a pinhole to limit the depth of field). The device is positioned perpendicular to the object and scans the surface, capturing a series of high depth resolution images of the object. Each image is then digitized and converted to x-y-z coordinates and topographical maps are created and roughness information can be calculated.

Stylus profilometry has been tested on stone materials with varying amounts of success.²⁷ Measurements are made by an instrument with a metal stylus that traverses a line on the subject. Once the stylus records the topography, the roughness value is presented as the roughness average (Ra). This is defined as the arithmetic average of the absolute values of the measured heights from the mean surface taken within an evaluation area.²⁸

Applications

Profilometry techniques are usually applied to smaller subjects or sample areas and are usually performed in laboratories. Thus their *in situ* application for stone subjects is limited, however surface roughness and loss quantifications have

26 Park, "Laser Ultrasonic Inspection System," 1051 – 1052.

27 Grissom et al., "Measuring Surface Roughness," 75.

28 Ibid.

been successful. Interestingly, a comprehensive evaluation of tools measuring roughness, i.e. texture change after cleaning, concluded that the tactile method (feeling the samples) produced the same results for roughness as stylus profilometry (although with a less technical and more relative roughness value) and was more cost effective than laser profilometry. In addition, it was noted that use of the stylus and laser profilometry techniques in the field “would not make sense when such a simple technique as touch evaluation can bridge the range of surface texture found on stone, including both roughness and waviness.”²⁹ Thus its widespread use in characterizing stone, especially *in situ*, is at the very least problematic.

Photogrammetry

As defined by Rory Stangridge, photogrammetry is “the practice of obtaining information about physical objects through the process of recording, measuring, and interpreting photographic images”.³⁰ It can provide either two or three-dimensional measurements and requires scale-rectified photographs (orthophotos) on which to base these *photogrammetric measurements*. This technique is now a ubiquitous part of metric surveying and documentation in heritage preservation. Early photogrammetry can be classified as *indirect, manual, digital, analog* and *non-destructive* techniques because hand measurements were extracted from photographs. However, digital photography and computer-aided design software has transformed current photogrammetry techniques into *indirect, digital* and usually *non-destructive* (does not require damage to the subject unless permanent targets must be installed) techniques.

29 Grissom, “Measuring Surface Roughness,” 81.

30 Rory Stanbridge, “Photogrammetry- A Practical Guide,” *The Building Conservation Directory* (1995, article updated 2005), <http://www.buildingconservation.com/articles/photogram/photogram.htm>.

History

Architectural photogrammetry began in 1858 when Albrecht Meydenbauer, a German surveyor of the Prussian government, had an accident while undertaking a surveying of a cathedral in Wetzlar, Germany. He was thereafter inspired to explore methods of indirect measurements in photographic images. Benefits he cited include the fact that photographic images can store the object information in great detail and with high accuracy. He also argued that the images would provide archival records should cultural objects be lost, and thus he developed the idea of a cultural heritage archive.³¹ In 1867, sixteen years after the first photogrammetrical device was developed by Aime Laussedat, Maydenbauer began to build the first architecture-specific instruments that combined both a wide-angle lens photographic camera with a measuring instrument. His solutions established the basic principles of all subsequent photogrammetric cameras used in architectural photogrammetry.³²

The Technique and Equipment

Photogrammetry is a remote-sensing process that can produce: coordinates of the required object-points, topographical and thematic maps, or orthophotographs (rectified photos). For the purposes of quantifying and monitoring stone deterioration, close range photogrammetry is preferable and can be performed with metric cameras, stereometric (3D) cameras, or standard cameras. These can be either film-based (analogue) or digital. In order to extract

31 Jörg Albertz, "Albrecht Meydenbauer: Pioneer of Photogrammetric Documentation of the Cultural Heritage."

32 Jörg Albertz, "Albrecht Meydenbauer: Pioneer of Photogrammetric Documentation of the Cultural Heritage," *Proceedings from the XVIII International CIPA Symposium, Potsdam, Germany, September 18 – 21, 2001*, 19 – 25.

measurements from a photograph, it is necessary to map the path that light rays travel from the object, converge at the camera lens, and then refract according to the focal length of the camera and the lens distortion. To perform this requires knowledge of the internal geometry of the camera and is the differentiating factor between camera types.

For example in the metric camera, which produces 2D images, the lens distortion is very low and the internal geometries are known and stable. These have several important implications. Because the internal geometries are stable, there is no zoom or focus, which means that each metric camera is only usable within a limited range of distances toward the object. Additionally, a coordinate system is automatically included in the photograph because the camera defines the coordinates according to four markings mounted on its frame.³³

The development from 2D to 3D photogrammetry is aided by the stereometric camera, which consists of two metric cameras mounted at either end of a bar of a known length. Three dimensional photogrammetric images can also be taken using two separate metric cameras at a known distance. The distance between the two cameras (or the length of the bar in a stereometric camera) determines the offset distance between their images (called the stereopair). When these photographs are overlapped at the appropriate scaled, offset distance they create a 3D appearance by simulating normal human 3D vision.³⁴

The photogrammetric process may also be undertaken with typical commercial cameras where the internal geometry is not stable and is unknown. This process requires many control targets at known intervals to be placed on

33 Aerial Archive, "Introduction to Photogrammetry," Aerial Archive at the University of Vienna, <http://www.univie.ac.at/Luftbildarchiv/wgv/intro.htm>.

34 Ibid.

the subject. These are then used to rectify and scale the image using software programs. While this is not considered to be highly accurate, it is a relatively simple process that requires an inexpensive camera and is therefore considered an acceptable form of documentation.³⁵

Manually extracting measurements from the photographs has been possible since the technique's inception in the late 1850s. Two dimensional coordinates can be mapped from a single orthophotograph or from a non-rectified photograph if the object is flat (such as a building façade) and if the camera plane was vertical and parallel towards the object. In this type of measurement, at least one distance between targets must be known. Calculating measurements from orthophotos and stereophotographs through analogue measurement equipment was the primary method until the 1970s. Since the 1970s, computers have been used to calculate the relationship between the image and real-world coordinates. However, contemporary digital methods of analysis that use computer-aided design software and specialized photogrammetric software are currently the most common forms for analysis. These require digital images from which the position and intensity value of each pixel is recorded. Digital images also allow for photogrammetric analysis of several photographs in either 2D or limited 3D perspectives.³⁶

Applications

Benefits of the technique include its non-contact qualities, although if the operator does not have a metric camera then targets at known intervals must be placed on the subject for rectification, thus weakening its non-contact nature. Additionally, because it

35 Ibid.

36 Ibid.

is non-contact, it is open to random, systematic and unforeseen sources of error that must be controlled for during the recording process. Because high resolution images are taken of the subject, detailed surface information can be captured, such as deterioration conditions which can be seen in the photographs. It is also relatively simple and easy to learn, increasing work speed and reducing the amount of equipment brought into the field. There is also a large price range for equipment, which allows this technique to be suitable for low-cost, low resolution projects that require lower levels of expertise, as well as high-budget projects that require high levels of accuracy and where specialized personnel are available to perform the survey.³⁷

Currently, photogrammetry is frequently coupled with other survey methods. Photogrammetric applications include base-line visual information of stone surfaces (such as color and orientation). It can also be used for qualitative, long-term monitoring by visually comparing photographs of different time periods. Quantitative information can be computed by mapping conditions onto the photos and extracting quantities of surface conditions (which is further discussed at the end of this chapter). Winkler developed macro-stereogrammetric techniques to measure surface conditions of marble where feature sizes are at least .02mm. It can be used to study effects of cleaning, such as roughening, on marble as well as to study the progressive cracking of crystalline marbles.³⁸ This technique was later used to perform stress analyses on microcracks in stone elements at the Field

37 Antonio Almagro, "Simple Methods of Photogrammetry: Easy and Fast," *Proceedings from the XVIII International CIPA Symposium, Potsdam, Germany, September 18 – 21, 2001*, 32 – 38.

38 E.M. Winkler, "A Macrostereogrammetric Technique for Measuring Surface Erosion Losses on Stone," in *Cleaning Stone and Masonry: ASTM Special Technical Publication 935*, ed. James R. Clifton (Philadelphia: American Society for Testing and Materials, 1986), 153 – 161.

Museum of Natural History in Chicago.³⁹

Microerosion Meter (MEM)

These are hand-held tools that can be used to determine quantities and rates of loss at the micro-scale at resolutions as high as 2 μm . They are *quasi-manual*, *direct*, and *destructive* measurement tools. The instrument was first developed by the Department of Geography at the University of Bristol for measuring loss on limestone surfaces but can be applied to a wide range of stone, including marble.⁴⁰

The Technique and Equipment

The process requires the operator to record single-point readings at the exact same location on the stone surface over a period of time. Differences between measurements are then calculated to determine quantities and rates of loss. The tool is composed of an engineering calibrated dial gauge mounted on a metal stand with three legs (Fig. 2). It is registered in the same location by fitting each leg into a reference stud that is permanently embedded in the subject.

39 E.M. Winkler and M. Kirchmayer, "Weathering of Crystalline Marble at the Field Museum of Natural History, Chicago" *APT Bulletin* 23, No. 4, (1991): 43-47.

40 D.I. Smith, "The Micro Erosion Meter: Its Application to the Weathering of Rock Surfaces" (paper presented at the International Workshop on the Conservation of Rock Art, Perth, September 1977): 44.

Fig. 2: The Microerosion Meter

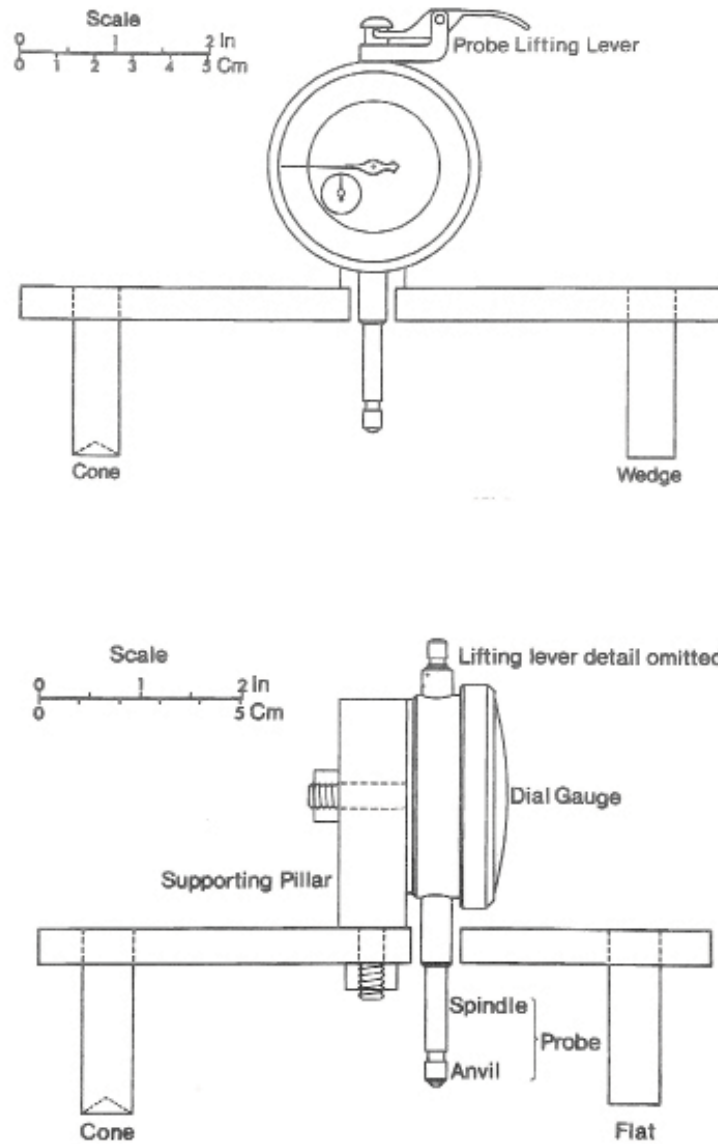

Source: High and Hanna, "A Method for the Direct Measurement," 24," reprinted in Smith, "The Micro Erosion Meter," 45.

Placement of the reference studs causes damage to the subject and is therefore considered a destructive tool and would typically not be appropriate for highly fragile or sensitive subjects. Another disadvantage is that only three

measurement points can be taken by a traditional MEM within the footprint of the reference stud (the instrument can be rotated 120 degrees and each leg placed in a different stud). This limited number of measurement points is a disadvantage when attempting to measure the loss over a highly variable surface. New MEM models, called traversing microerosion meters, allow many more points to be taken within the triangular footprint. Additional disadvantages occur if the erosion is due to granular disintegration and if the grain sizes are smaller than the length and diameter of the probe tip, making micro-scale measurements difficult or impossible.⁴¹ However advantages of MEMs include: high accuracy at the micro-scale, and relative ease of use.

Applications

This technique has been used to monitor cave faces as a proxy material to test the loss on adjacent faces with rock art. If loss of surface material was occurring, it was hypothesized that similar areas without rock art might have once had them, but were lost to erosion processes.⁴² It should be noted that if proxy materials must be used to measure deterioration, the measurements lose the accuracy and confidence levels that they would have if direct measurement of the actual material was taken. Another application includes measuring loss over twenty years on the balustrade at St. Paul's Cathedral in London. Because measurement occurred over such a long time period, the team was able to determine that erosion rates were higher from 1980 to 1990, which could be correlated to higher sulfur dioxide levels in London of the same time period. The

41 Ibid.

42 Ibid.

erosion rates then decreased from 1990 to 2000 as sulfur dioxide levels dropped and atmospheric conditions improved.⁴³

3D Laser Scanners

Basics

Three-dimensional laser scanners are *digital, indirect*, and usually *non-destructive* survey tools. In general, they digitize surface information by using lasers and internal computational systems to perform measurements. The resulting data set (called a point cloud) from a single scan is a series of single-point measurements at set intervals that are recorded in a three dimensional coordinate system. Using post-processing software, single scans are then joined (registered) to create the complete point cloud of the subject. Using either the same specialized point-cloud software as the registration process, or using more ubiquitous software, dimensional information can then be extracted from the point cloud. Three dimensional laser scanners were originally developed to provide a means for quality control in the reverse-engineering and manufacturing of industrial replacement parts. Currently, they are used by many industries, including manufacturing, geology, and heritage preservation. Information gathered from the point cloud can be used for computer-aided activities (CAD, CAE, CAM, CAGD) that result in milling and reproduction, structural monitoring, and providing base-line survey documentation.

With the exception of regulations regarding the use of lasers in open areas, there are few standards that guide the use of 3D laser scanning. Several fields are still in testing phases for uses such as adopting it as a standard tool

43 S.T. Trudgill et al., "Twenty-Year Weathering Remeasurements at St. Paul's Cathedral, London." *Earth Surface Processes and Landforms* 26 (2001): 1129-1142.

for evaluating pavement roughness⁴⁴ and slope movement monitoring.⁴⁵ Protocol can also be gleaned from case studies and professional training, however no ASTM or RILEM standards currently exist. Additionally, there are no national or industry standards regarding how the data should be processed, disseminated, or archived.

The Technique and Equipment

In general, the laser scanner (or scanning station) is placed at a given distance from the subject, the laser beam leaves the scanning device, contacts the subject and the device calculates the contact point. This is repeated over the entire subject surface from one scanning station position and the resulting point cloud from a single position is considered one scan. The process is repeated from a different position in order to capture areas of the subject that were not captured in the first scan (Appendix A). The scan from the first position is then registered to the scan from the second position by 1) matching targets that were strategically placed around the subject, 2) cloud-to-cloud registration, or 3) surface-to-surface registration. Target-based registration matches the targets while cloud-to-cloud registration aligns the point clouds of the different scans by using point cloud overlap to determine the positions of the scans relative to each other. Surface-to-surface registration is a recent development that uses an algorithm that estimates the Euclidian distances between surface patches according to their “best fit” and tries refine the match.⁴⁶ Target registration is the most appropriate

44 J.R. Chang, K.T. Chang, and D.H. Chen, “Application of 3D Laser Scanning on Measuring Pavement Roughness,” *Journal of Testing and Evaluation* 34, no. 2 (March 2006): 83 – 91.

45 A.K.L. Kwong, L.G. Tham, and B.A. King, “Application of 3D Laser Scanning Technique to Slope Movement Monitoring,” *Journal of Testing and Evaluation* 33, no. 4 (July 2005): 266 – 273.

46 José Luis Lerma García, Bjorn Van Genechten, Erwin Heine, and Mario Santana Quintero, ed., *Theory and Practice on Terrestrial Laser Scanning Training Material Based on Practical*

method for laser scanning of heritage subjects because it yields the highest amount of accuracy and certainty of data. Registration can be performed on or off site, however it is preferable to perform registration on-site to check for error; the opportunity is then available to repeat the scan if gross error occurs. As will be discussed in Chapter 3 geo-referencing is necessary in order to perform long-term monitoring. It is generally appropriate to always geo-reference data collected for any purpose. Universal coordinate information can be established by placing permanent survey markers at the location of each scanning station as well as by installing permanent, rather than temporary, registration targets. Establishing permanent markers for geo-referencing purposes corrupts the non-destructive qualities of the tool and reduce its application possibilities for monitoring highly sensitive objects *in situ*.

The type of scanner will determine the range of distance from the subject at which the station must operate (operating range). The scanner type will also determine how the contact location is calculated, the speed at which the data is gathered, the scan resolution (distance between points), and whether or not image and color information is captured with each scan.

There are four categories of laser scanning technology: triangulation-based, terrestrial time-of-flight, terrestrial phase comparison, and airborne (sometime referred to as LiDAR). Table 1 outlines scanner types and their accuracy and resolution ranges. Within each category, the scanners can acquire data by one of two methods: statically or a dynamically. A static scanner keeps a fixed position during the acquisition process and is considered to be more precise and yield a higher point density. In contrast, a dynamic scanner is mounted on a mobile platform that must have an integrated referencing coordinate system (such as GPS).

**TABLE 1:
THREE DIMENSIONAL LASER SCANNERS TYPES ACCORDING TO RESOLUTION CAPABILITY**

Laser Scanner	Resolution Capability (accuracy @ operating range)	Operating Range Description
Triangulation	.05mm-1m @ .1m - 25m	Close-range
Terrestrial Time of Flight	3-12mm @ 2-100m	Mid-range
Terrestrial Phase Comparison	5mm @ 2-50m	Mid-range
Airborne	.15m @ 10 - 3500m	Long-range

Lions →

(English Heritage 2007, 7)

POINT CLOUD RESOLUTION ACCORDING TO SUBJECT SIZE

Subject Size	Example	Point Cloud Resolution required to give 66% probability that the feature will be visible	Number of points per 1 sq/m required to give 66% probability that the feature will be visible	Point Density required to give 95% probability that the feature will be visible	Number of points per 1 sq/m required to give 95% probability that the feature will be visible
1000mm	large earth work	3500mm	0.1	500mm	4
1000mm	small earth work	350mm	8.16	50mm	400
100mm	large stone masonry	35mm	816.28	5mm	40,000
10mm	tool marks	3.5mm	81,632.57	.5mm	4 million
1mm	weathered masonry	.35mm	8,163,257.14	.05mm	400 million

Lions →

(English Heritage 2007, 10)

When assessing different types of laser scanners, it is important to remember that as the distance between the scanner and the subject increases, enabling large subjects to be captured, there is a corresponding decrease in resolution capabilities and accuracy levels. Potential sources of error when using laser scanners, are outlined in Table 2.

Triangulation scanners

These scanners calculate three dimensional coordinates of each measurement point by using triangulation calculations. The scanners can be mounted on arms or portable tripods for *in situ* scanning. Robotic arms are often referred to as “hand held scanners” and work best in laboratory environments, however they can also be used for *in situ* scanning. If the object is small and can be removed from its location, it may also be placed on a rotating turntable and scanned by a stationary scanner. Triangulation scanners require closer operating ranges than other types of scanners, but consequently usually have higher resolution capabilities and accuracy levels. However, they are only suitable for smaller objects (clay pots or detailed carvings on facades) and they perform badly in bright sunlight and require shading.⁴⁷

The “triangle” referred to in the technique’s name is formed by the laser spot or strip on the subject, an internal camera, and the laser emitter (Figs. 3 and 4). The angles of the formed triangle are then calculated when the internal CCD camera with a known distance from the laser emitter locates and records where the laser contacts the subject within its field of view. The device is then able to compute distances to the subject and the XYZ coordinates of the measurement point. The mechanics of this technique are very similar to those used by metric cameras in photogrammetry, as described above.

47 *3D Laser Scanning for Heritage* (English Heritage, 2007), 8.

Terrestrial Time-of-flight (or Pulse) Scanners

These scanners calculate the XYZ coordinates of the measurement point using mirror angles, the known speed of light, and the time of flight for an emitted laser pulse to strike and reflect off the object and return to the device (Fig. 5). These scanners are usually mounted on tripods and operate at mid-range distances from the subject. They also have slightly larger resolution ranges and lower accuracy levels than triangulation-based scanners, and are therefore more suited for capturing general architectural information, such as building facades.⁴⁸ They are also optimal for measuring larger structures because they are usually able to scan in 360 degrees in the horizontal and 180 degrees in the vertical.⁴⁹

Phase-comparison scanners

These are similar to time-of-flight scanners regarding distance and accuracy ranges, however they measure point locations by calculating differences in the signal between the emitted and returning laser pulses (Fig. 6). This allows these scanners to capture more information at faster rates, although it has been demonstrated that the resulting immense quantity of data causes problems during the post-processing period.⁵⁰

Airborne laser scanners

The scanner operates from an airborne platform (such as in an airplane) and records the topography of the earth's surface. The scanner uses the same laser pulse measurement techniques as time-of-flight or phase-comparison

48 Ibid.

49 Ibid.

50 Ibid.

scanners, but GPS and inertial sensors are included to record the orientation and position of the scan station on the aircraft during the scanning process. Location information is necessary to calculate the XYZ coordinate of where the laser pulse struck the subject.

Fig. 3: Triangulation 3D Laser Scanner Operation

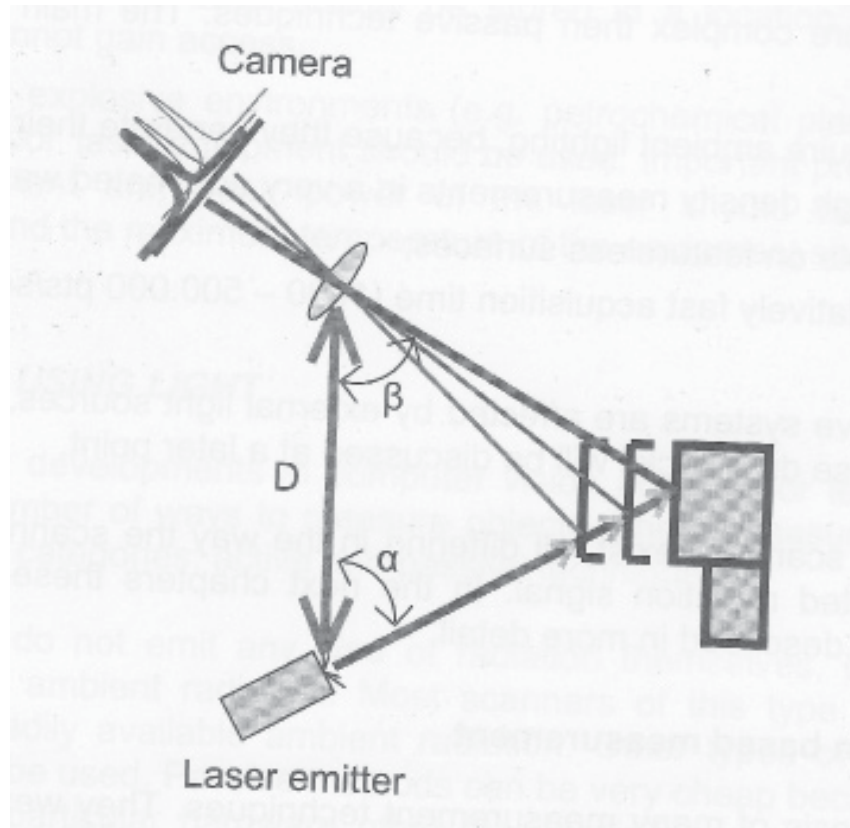

(Source: García et al., *Theory and Practice on Terrestrial Laser Scanning*, 22).

Fig. 4: Laser Shape Projections for Triangulation 3D Laser Scanners

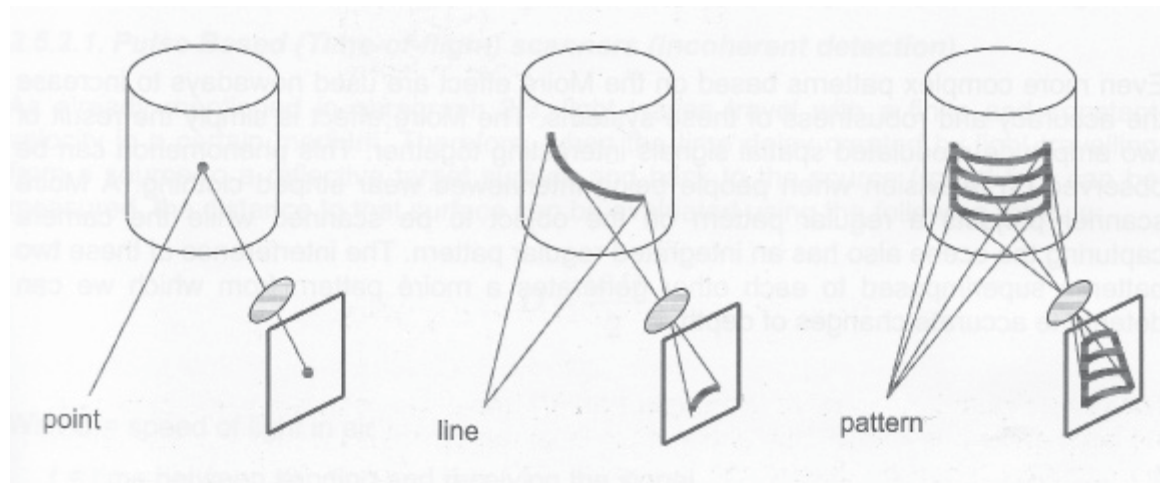

(Source: García et al., *Theory and Practice on Terrestrial Laser Scanning*, 23).

Fig. 5: Time-of-flight 3D Laser Scanner Operation

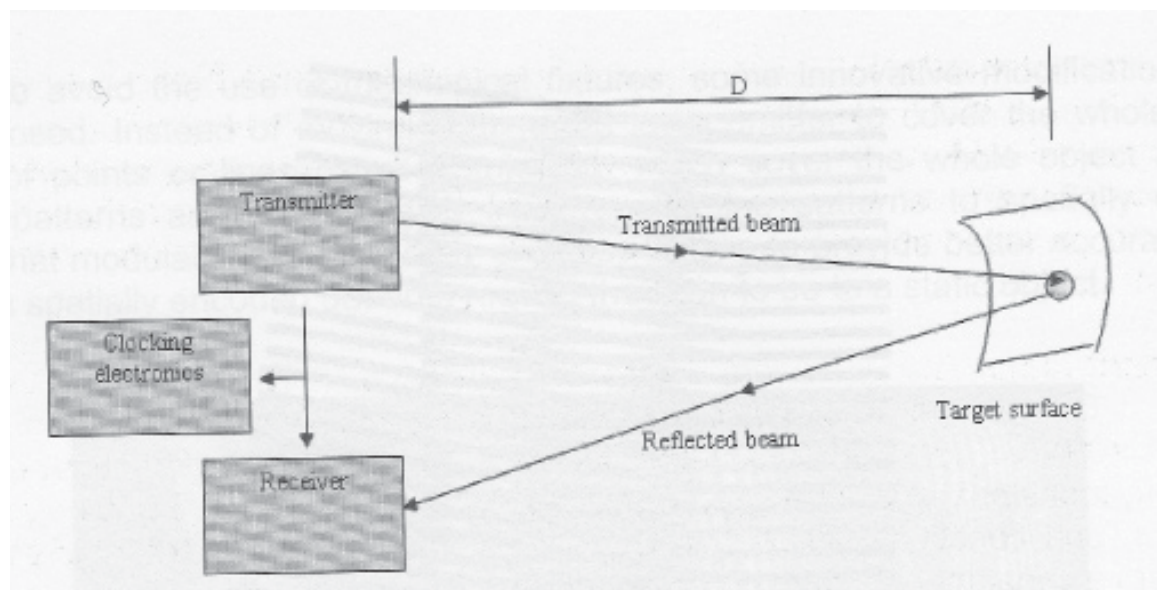

(Source: García et al., *Theory and Practice on Terrestrial Laser Scanning*, 26).

Fig. 6: Phase Comparison 3D Laser Scanner Operation

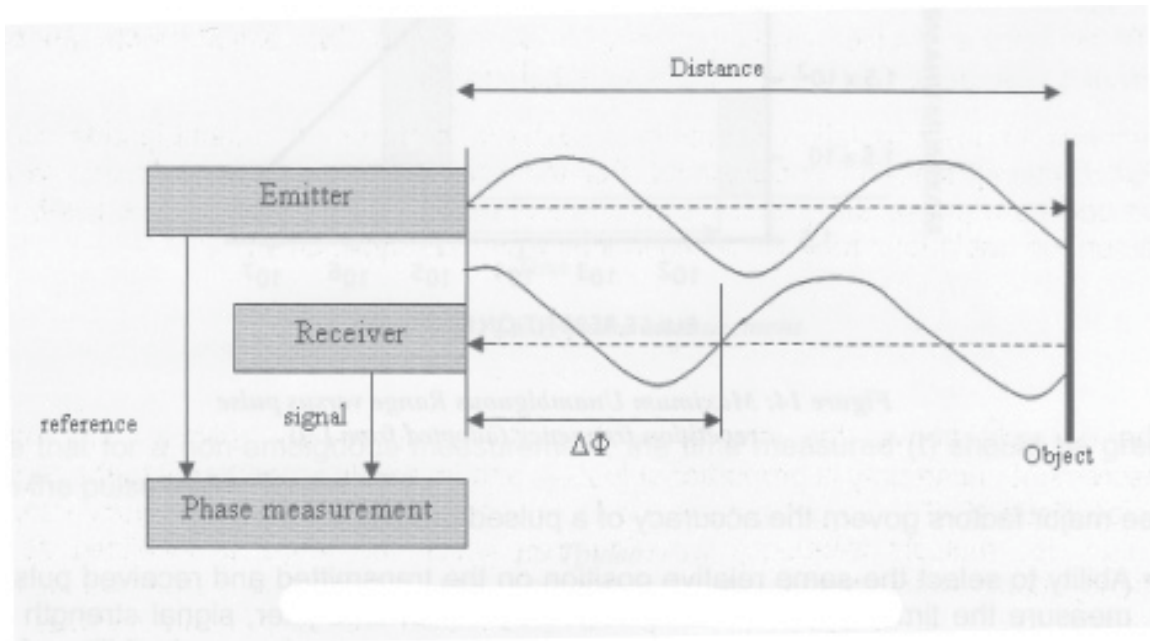

(Source: García et al., *Theory and Practice on Terrestrial Laser Scanning*, 28).

Applications

Applications of 3D laser scanning that seek to investigate conditions on stone subjects usually focus on dimensional change of the subject when there is gross structural movement or deformation. A few interesting projects integrate a database with point cloud data to consolidate spatial information, photographs, and treatment history.^{51&52}

51 M. Brizzi, S. Court, A. d'Andrea, A. Lastra, and D. Sepio, "3D Laser Scanning as a Tool for Conservation: The Experiences of the Herculaneum Conservation Project" *The 7th International Symposium on Virtual Reality, Archaeology and Cultural Heritage VAST* (2006).

52 Stuart Robson and Spike Bucklow, "Conserving the Westminster Retable," University College, London.

Table 3: Applications of 3D Laser Scanning in Heritage Preservation

Deliverables	Documented Applications	Examples	Object Size	Scanner Type
Quantitative Data for Monitoring & Diagnosing	Deformation monitoring of large structures	Dam deformation; deformation of church vaulting, dimensional response (expansion and contraction) of wood	Medium to Large	Mid-range
2D Working Drawings	Extracting 2D and 3D measurements in computer-aided design software to create plan and elevation drawings for archival records and diagnosing conditions	Condition surveys; elevation and plan drawings	Medium to Large	Mid-range
Base-line Records	Geometric modeling for archival purposes	Visual records of excavations at archaeological sites; 3D archival records of fragile objects; 3D archival records of objects prior to intervention; educational outreach	Small to Large	Close-range & Mid-range
	Geometric modeling for CNC-machining or other replication	Replicating sculptures	Small to Medium	Close-range
	Survey at an inaccessible site	Underground caves, grottos, mesa dwellings	Medium to Large	Mid-range
	Topographic analysis	Mapping petroglyphs; historic landscapes	Small to Large	Close-range & Mid-range

There are very few documented monitoring cases that successfully use 3D laser scanning to detect material loss on the micro-scale (.05mm to .005mm) over time.⁵³ Additionally, some types of stone may visually exhibit expansion while actually having net surface loss.⁵⁴ While documented examples are shown to use 3D laser scanning to monitor both swelling and shrinkage of wood, there are no examples for monitoring stone expansion.⁵⁵ Finally, there are no documented examples of conditions mapping onto a 3D model generated from the point cloud.

Erosion Pins

The Technique and Equipment

Erosion pins are *manual, indirect, destructive* tools. They are used to measure the rate of loss from different locations on a surface, such as on different areas of stone walls. The data is used to further understanding about pathologies causing weathering and to identify critical areas of loss or potential loss. The technique is performed by inserting pins at selected sampling points on the subject. Factors used to identify appropriate sampling locations include: subject orientation, exposure, configuration or assembly, and presence of architectural features.⁵⁶ The material of the pin should have compatible strength and thermal properties as the subject material to prevent damaging the subject or having faulty readings.

53 T. Barnett, A. Chalmers, M. Diaz-Andreu, G. Ellis, P. Longhurst, K. Sharpe, and I. Trinks, "3D Laser Scanning for Recording and Monitoring Rock Art Erosion," *International Newsletter on Rock Art (INORA)* 41 (2005): 25-29.

54 E.M. Winkler, "Stone Weathering: A Rebuttal." *APT Bulletin* 19, no. 3 (1987): 3

55 Łukasz Bratasz, Romon Kozłowski, Dario Camuffo and Emanuela Pagan. "Impact of Indoor Heating on Painted Wood: Monitoring the Altarpiece in the Church of Santa Maria Maddalena in Rocca Pietore, Italy," *Studies in Conservation* 52 (2007): 199 – 210.

56 Anne Oliver, "A Preservation Action Plan for Fort Union," *CRM* no. 10 (1997): 14.

If, adhesives are used to secure the pins, they should be minimally invasive and have compatible expansion, temperature, and strength properties. The initial exposed length of the pins from the head to the subject is measured and differences in length between the initial reading and subsequent measurements are calculated. The rate is then determined according to the amount of material loss over the measurement period. This technique can be applied when determining weathering rates at the micro and macro scales. Advantages of this technique include low cost, ease of installation, and simplicity of measurement. However disadvantages include human-induced error in measurement readings, damage to the material, and potential error from environmental forces.

Applications

Applications of this technique have been successful in measuring loss on the millimeter scale of adobe walls at Fort Union National Monument⁵⁷ and at El Morro National Monument in New Mexico.⁵⁸ Macro erosion rates of stream banks⁵⁹ and of military earthworks have also successfully been calculated.⁶⁰

Moulds

Tools in this category are *manual*, *indirect*, and are formulated to be *non* –

57 Anne Oliver, "A Preservation Action Plan," 13 – 15.

58 A. Padgett, *Assessment of Deteriorative Factors Affecting the Inscriptions, El Morro National Monument, New Mexico, Report for the National Park Service* (Philadelphia: University of Pennsylvania Department of Historic Preservation, 1992).

59 G.N. Zaines, R.C. Schultz, and T.M. Isenhardt, "Stream bank erosion adjacent to riparian forest buffers, row-crop fields, and continuously-grazed pastures along Bear Creek in central Iowa," *Journal of Soil and Water Conservation* 59, no. 1 (2004): 19 – 27.

60 W.M. Aust, A. Azola, and J.E. Johnson, "Management effects on erosion of Civil War military earthworks," *Journal of Soil and Water Conservation* 58, no. 1 (2003): 13 – 20.

destructive. Mould making is an old technique whereby moulds are created when a material is applied over a subject, allowed to set, and then removed. Traditionally, they have been used to create castings and replicas of objects and surfaces, however they can also be used to analyze surface conditions of objects (such as tool markings or surface roughness). They usually involve a two-phased process: protecting the subject by coating it in a barrier layer and then taking the mould. When the objective is to study surface conditions, the barrier layer cannot obstruct the contact of the moulding material with the details of the subject's surface, however it should also be reversible and sufficiently protect the subject from the moulding material.⁶¹ Mould materials found to be particularly successful for marble include latex rubber applied in thin layers and reinforced with gauze with a Cyclododecane barrier, although it has been noted to exhibit a short life with extreme shrinkage from loss of water during the drying process. Other materials include natural rubbers, polyurethane rubbers, polysulphide rubbers, silicone rubbers, water-based alginates, however all exhibit some disadvantages.⁶² Silicone rubbers in particular have been found to leave oil-like stains on terracotta substrates when barriers are not applied. However, because they capture high levels of detail, cure at greater thicknesses and have sufficient release properties with long-term stability of the mould, they were a favored material.⁶³ The oldest techniques, first used in the early twentieth century, include paper squeezes made with thin paper or paper pulp. Such techniques were used at El Morro National Monument in 1911.⁶⁴

61 Jeffrey Maish and Erik Risser, "A Case Study in the Use of Cyclododecane and Latex Rubber in the Moulding of Marble," *JAIC* 41, no. 2 (2002): 128.

62 Maish, "A Case Study," 129.

63 Jeffrey P. Maish, "Silicone Rubber Staining of Terracotta Surfaces," *Studies in Conservation* 39, no. 4 (Nov., 1994): 250.

64 Padgett, *Assessment of Deteriorative Factors Affecting the Inscriptions, El Morro Nation-*

As discussed, there are successful applications for using moulds to characterize and analyze stone surfaces. Advantages include the ability to perform destructive testing to the mould, however disadvantages include necessary specialized skills in mould making and its application as well as eventual deterioration of the mould. Additionally, moulds do not provide a direct measurement technique but rather an indirect measurement technique that requires a secondary, complementary measurement methods to extract quantitative data. One unexplored use is to create moulds in field and later laser scan them in a laboratory setting. This might preserve funds, time, create documentation of the surface in a less corrosive medium, and increase the accuracy of the laser scanning process by undertaking it in a controlled environment.

Graphic Condition Surveys

Condition surveys are ubiquitous tools for identifying and quantifying surface conditions in order to diagnose and treat heritage subjects. They can be both *digital and manual, and are indirect and non-destructive*. Traditionally, they have been created by taking a 2D representation of the subject, such as orthophoto or architectural drawings, and graphically representing the conditions on overlays in a color and pattern coded scheme. The overlays can then be stacked for analysis or the recorded conditions can be converted into a digital format through computer-aided drafting software and then digitally overlaid for analysis.

Advantages of this technique include:

- Portability of the materials, which allows flexible movement in areas of

limited access.

- Simplicity of the materials, which avoids failures and complications of computers or other digital equipment while in the field.
- If conditions are recorded on photographs, their inherent accurate representation of the subject helps the field worker to correctly locate the observed conditions on the photograph.

Limitations include:

- Loss of time during the digitization process unless digitized directly in the field on PC Tablets.
- Potential (although not definite) decrease in accuracy during the digitization process.
- Constraints of recording conditions of 3D surfaces on 2D representations.

Successful applications of this technique include mapping conditions on gravestones, facades, sculptures, furniture and finished surfaces (such as frescos). Ideal subjects that yield the best outcomes are those which can be easily represented in 2D (such as a façade) rather than 3D (such as a sculpture with a large amount of curvature) do to the inherent properties of 2D photographs and computer-aided drafting software. This has been somewhat overcome with the use of stereophotography, however, the final product is still composed of stacked 2D photographs; objects in the z plane are not captured and any conditions in the this plane cannot be recorded.

Summary

The selection of each tool will depend upon the character of the stone and the project parameters. Understanding this relationship will determine the accuracy and success of the monitoring program.

Chapter 3) Quantifying and Monitoring Standards and Objectives for Heritage Sites

There are two bodies of literature that comprise the subject of laser scanning for quantifying and monitoring surface conditions of stone subjects in heritage preservation. Because quantification requires the heritage specialist to gather and record data, often *in situ*, the first body of literature relates to the standards and practices for recording (a term that is synonymous with documentation, measured survey and metric survey) at heritage sites. The second body of literature discusses monitoring standards for heritage sites. Both sets concurrently discuss how to visually represent the information and use such information to achieve final objectives. While recording and monitoring standards for specific tools and technologies have developed, there are also over arching standards that have become integrated into the preservation planning and stewardship process.

The following sections first identify general documentation standards and describe how they have developed. Principle criteria for planning monitoring programs and selecting tools are then outlined and described according to how they apply the 3D laser scanning process.

Recording

Inception and Development within the Literature

Recording in heritage preservation has been openly accepted as a basic component of the preservation process since the Venice Charter of 1964. However, the importance of documentation has actually been recognized in the United States since 1933 when the national government created the Historic

American Buildings Survey “to document America’s architectural heritage.”⁶⁵ The ensuing breadth of publications related to the role of documentation in the preservation planning process as well as specific documentation approaches from the last quarter of the nineteenth century to present, reinforce its critical role within this field. As the preservation field develops and adjusts to a digital world, so too do documentation standards. In The Venice Charter of 1964, ICOMOS makes a general proposition that “there should always be precise documentation in the form of analytical and critical reports, illustrated with drawings and photographs”⁶⁶ while the Burra Charter of 1999 expands this statement by asserting that documentation is an integral part of the preservation process because “the cultural significance of a place and other issues affecting its future are best understood by a sequence of collecting and analyzing information before making decisions.”⁶⁷ While both acknowledge its importance, neither article fully enumerates how this should be achieved or what should be the final form.

The vagueness of most documents allows their founding principles to be flexible and applicable to varying circumstances. Yet more developed and more specific literature was ultimately necessary for two reasons. First, the role of preservation expanded beyond static, architecturally historical buildings, and now focuses on the more dynamic stewardship of the built environment. This has required documentation methods to capture more diverse subjects in increasingly variable (and challenging) contexts. Second, technology and digital media have become so entwined with contemporary professional practices that clients

65 National Park Service, “HABS Guidelines,” National Park Service, US Department of the Interior, <http://www.nps.gov/history/hdp/habs/index.htm>

66 “Article 16,” *The International Charter for the Conservation and Restoration of Monuments and Sites (The Venice Charter)* (set forth by the 2nd International Congress of Architects and Technicians of Historic Monuments/ ICOMOS, Venice, Italy, 1964).

67 “Article 6.1,” *Australia ICOMOS Burra Charter* (set forth by the Australia International Council on Monuments and Sites, Burra, South Australia, November, 1999).

demand contemporary technologies and modes of visual representation. Some of these technologies are time saving and so are also preferred by the practitioner. Consequently, both professional and legislative documents have developed to define specific purposes and parameters for documentation. Such documents include:

The Surveying of Archaeological Sites (1988),⁶⁸ *Commentary 24: Documentation*, in *Commentaries to the Guidelines for Practice of the AIC* (1996),⁶⁹ *Principles for the Recording of Monuments, Groups of Buildings and Sites* (1996),⁷⁰ the *Secretary of the Interior's Standards and Guidelines for Architectural and Engineering Documentation* (1999),⁷¹ *Documenting the Cultural Heritage* (1998),⁷² *With Alidade and Tape: Graphical and Plane Table Survey of Archaeological Earthworks* (2002),⁷³ *Survey Methodology for the Preservation of Historic Burial Grounds and Cemeteries* (2003),⁷⁴ *Methods for Monitoring the Condition of Historic Places* (2003),⁷⁵ *Documentation for Conservation: A Manual for Teaching Metric Survey Skills* (2006),⁷⁶ *Understanding Historic Buildings: A Guide to Good Recording Practice* (2006),⁷⁷ *Documentation and Information Management for the Conservation of Heritage Places: Illustrated Examples* (2007).⁷⁸

68 Leach, Peter, *The Surveying of Archaeological Sites* (London: Institute of Archaeology Publications, 1988).

69 AIC, "Commentary 24: Documentation," *Commentaries to the Guidelines for Practice of the AIC*, 1996. <http://aic.stanford.edu/pubs/comment24.html>

70 *Principles for the Recording of Monuments, Groups of Buildings and Sites* (ratified by the 11th ICOMOS General Assembly, Sophia, Bulgaria, October, 1996).

71 National Park Service, "HABS Guidelines," National Park Service, US Department of the Interior, <http://www.nps.gov/history/hdp/habs/index.htm> .

72 Robin Thornes and John Bold, *Documenting the Cultural Heritage* (Los Angeles: The J. Paul Getty Trust, 1998).

73 *With Alidade and Tape: Graphical and Plane Table Survey of Archaeological Earthworks* (English Heritage, 2002).

74 F.G. Matero and J. Peters, "Methods for Monitoring the Condition of Historic Places," *APT Bulletin* 34, no. 2/3 (2003) 38 – 39.

75 Tony Walton, *Methods for Monitoring the Condition of Historic Places* (Wellington: Department of Conservation, 2003).

76 Rand Eppich, Francois LeBlanc, English Heritage Technical Survey Archaeology, Divay Gupa, Peter Waldhausl, Robin Letellier, José Luis Lerma, John Hurd, *Documentation for Conservation: A Manual for Teaching Metric Survey Skills* (CIPA- RecorDIM, 2007).

77 *Understanding Historic Buildings: A Guide to Good Recording Practice* (English Heritage, 2006).

78 R. Eppich and A. Chabbi, *Documentation and Information Management for the Conservation of Heritage Places: Illustrated Examples* (Los Angeles: J. Paul Getty Trust and The Getty Conservation Institute, 2007).

Publications about documentation of cultural heritage gradually move beyond simply stating that recording is a required part of the preservation process, to outlining *why* it is important. Timothy P. Whalen, Director of the Getty Conservation Institute, recently wrote that heritage information is vital to the preservation field because “it is the basis for the monitoring, management and routine maintenance of a site and provides a way to transmit knowledge about heritage places to future generations.”⁷⁹ English Heritage enumerates the *why* by noting that surveying provides information on the form, condition, chronological relationships, relative chronology, function and dating of cultural landscapes.⁸⁰ US Department of Interior Secretary Standards write that documentation is a critical tool for determining the historical context (needed for effective preservation planning and for National Registration)⁸¹. Divay Gupta, Director of Programs for the Indian National Trust for Art & Cultural Heritage, similarly justifies record making and record keeping because it broadens “the experience of our cultural heritage” when used for *research, conservation, policy and planning, information management, and heritage awareness*.⁸² While these are varied responses to the question of *why* documentation is necessary, they all agree that it is critical to the success of the conservation process as well as an effective tool for fulfilling the mission of the field to preserve and convey heritage for future generations.

79 Robin Letellier, *Recording Documentation and Information Management for the Conservation of Heritage Places: Guiding Principles* (Los Angeles: J. Paul Getty Trust and The Getty Conservation Institute, 2007), vii.

80 *Understanding the Archaeology of Landscapes: A Guide to Good Recording Practice* (English Heritage, 2007).

81 National Park Service, *Secretary of the Interior Standards* (National Park Service, US Department of the Interior), 5 – 25.

82 Divay Gupta, *Identification and Documentation of Built Heritage in India* (New Delhi: INTACH, 2007), 12 – 13.

While the literature justifies documentation in the preservation field, it also demonstrates the evolution of technology. Peter Leach's explanation of baseline hand surveying relies on paces, measuring tapes and plumb-bobs (although he also discusses the more complex dumpy levels and theodolites) while the GCI's most recent publication on documentation describes the relatively newer and more technical, non-contact or indirect tools, such as laser scanners and GPS systems.⁸³ As documentation became more integrated into preservation practices, and as recording tools became more complex, heritage organizations and literature focusing on specific recording methods and technologies developed. For example:

CIPA- Heritage Documentation (an international scientific committee cofounded by ISPRS and ICOMOS in 1996); AIC- Electronic Media Group (EMG is an AIC specialty group with a mission to both preserve electronic-based materials and to provide a means for conservators to develop knowledge of and utilize new media in practice); RecordIM Initiative (5 year partnership between ICOMOS, CIPA and the GCI established in 2002); *Where on Earth Are We? The Global Positioning System (GPS) in Archaeological field survey* (2003),⁸⁴ *Application of 3D Laser Scanning on Measuring Pavement Roughness* (2006),⁸⁵ *3D Laser Scanning for Heritage* (2007),⁸⁶ *3D Risk Mapping: Theory and Practice on Terrestrial Laser Scanning* (2008).⁸⁷

As described below, these provide general standards and objective for surveying while also outlining detailed standards for specific technologies. They are

83 Eppich et al. ed. *Recording, Documentation and Information Management*, 2007.

84 *Where on Earth Are We? The Global Positioning System (GPS) in Archaeological field survey* (English Heritage, 2003).

85 J.R. Chang, K.T. Chang, and D.H. Chen, "Application of 3D Laser Scanning on Measuring Pavement Roughness," *Journal of Testing and Evaluation* 34. no 2. (March 2006), 83 – 91.

86 *3D Laser Scanning for Heritage* (English Heritage, 2007).

87 García et al. ed., *Theory and Practice on Terrestrial Laser Scanning*, 2008.

intended to be used both during the planning process and for fieldwork.

Guiding Standards and Objectives

There are multifaceted reasons for undertaking documentation and it is important to define the primary issues when surveying or recording at heritage sites. The GCI provides twelve guiding principles of heritage information management which can be used to form an overall plan for the documentation process. The basis for Gupta's principles is those described in *Principles for the Recording of Monuments* from the ICOMOS 1996 proceeding in Sofia Bulgaria as well as principles set out by the RecorDIM Initiative. He states that any documentation should 1) illustrate the significance of the site, 2) aim for quality and accuracy, 3) be accessible and 4) be clear.⁸⁸ English Heritage's more complex scheme divides the survey process into three primary categories: reconnaissance, observation and measurement, and depiction with numerous subcategories and principles. The Secretary Standards address both the larger reasons for documentation as well as provide specific principles to guide the documentation process.

The many different schemes for outlining standards and objectives can be confusing but several common points can be gleaned from the literature. First concerns the preservation planning process. Planning and implementing a survey can be very complex, especially for large sites or for projects with many different stakeholders. Therefore three unambiguous questions should remain at the forefront of the planning process: *what* is being surveyed, *why* is the data being collected? and *how* will it be used? While these are addressed in numbers ten and eleven of the GCI's principles and at the very end of the publications

88 Gupta, *Identification and Documentation*, 14 – 15.

by English Heritage and Divay Gupta, I would argue that they are actually the vanguard of the planning and implementation processes. Surveying is the first step in the conservation cycle and the data enables further understanding, interpretation and action at the site.⁸⁹ Additionally, the question of how the information will be used will help determine the scope of data collection for both surveying and monitoring. Therefore it is necessary to know 1) the form and complexity of the heritage site or object, 2) why documentation is necessary for that specific site (is the documentation part of a larger monitoring program?), and 3) how and who will use the information gathered (fund-raisers, historians, conservators?). Asking these straightforward questions is the first step in selecting appropriate tools and creating an implementation plan. The choices are then modified according to limitations on scope, cost, site accessibility, method repeatability, time frame, perceived risk and object complexity. The following specific criteria for a documentation program receive varying levels of attention. A few sources emphasize the importance of defining limiting factors of the project in order to help determine what recording tools are appropriate for the site and scope of the final deliverable.

Appropriate Scope

As described above, both publications by Gupta and English Heritage write that a project's circumstances will determine the level of detail at which information should be gathered. They provide a method for determining an appropriate scope by defining three levels of recording, ranging from little detail (lowest level) to very detailed (highest level) and correlating different deliverables with each scope. For example, a strategic heritage plan at the local level requires a low

89 Eppich et al., *Documentation for Conservation*, 2007.

level of data (such as photography and minimum written descriptions) to describe the distribution, condition and significance of relevant heritage buildings and sites. In contrast, an intervention requiring extensive repairs or alterations to a significant building would require a high level of documentation using drawings and photogrammetric records. Both authors assert that the purpose of the survey should be carefully assessed to ensure that the appropriate amount of time and money is allotted to the project, and the information gathered will address the needs of the project. This concept is more explicitly stated in the US Department of Interior Secretary Standards: methods and techniques of historical research should be chosen to obtain needed information in the most efficient way.⁹⁰ The Secretary's Standards continue by asserting that a plan with clear objectives and tasks should guide the documentation process in order to "define the proposed scope of the documentation work and to define a set of expectation based on the information available prior to the research."⁹¹ However, unlike the writings by Gupta and English Heritage, the Secretary Standards do not provide a method for determining scope.

Site Accessibility, Form and Complexity

The GCI's publication, *Recording, Documentation, and Information Management for the Conservation of Heritage Places* thoroughly conveys the intrinsic relationship between recording tools and characteristics of heritage sites by illustrating how different recording tools were selected for different field conditions.⁹² Through case studies, the publication shows how each project must be tailored according to the physical limitations of the site. For example,

90 NPS, *Secretary Standards*, 28.

91 NPS, *Secretary Standards*, 29.

92 Eppich et al. ed., *Recording, Documentation, and Information Management*, 2008.

a highly mobile, accurate and low maintenance (regarding both hardware and trained operating personnel) GPS system was used to record the location and features of *moai* (stone statues) on the Eastern Pacific island, Rapa Nui. Rapa Nui has a steep and rough terrain and the sculptures are scattered over the entire island. The mobility allowed data from a large area to be gathered within a short time frame and using limited resources. Because the data was mobile, it was transported back to Los Angeles and synthesized in the GCI lab.

The complexity and physical nature of a site will determine the speed of recording. Specific documentation tools and methods should be selected to accommodate for the rate of information gathering while also ensuring that they are able to capture the necessary data. As described above, site accessibility and required level of detail should be determined during the planning process. Accessibility and detail can then be weighed against the type of site (urban building vs. marshland) and its complexity (detaching finishes of a complex wall system vs. wall deformation of one room), to select appropriate documentation tools and create a balanced documentation method. The GCI case study describing their approach to *Rapid Assessment*, recorded the seismic performance of nineteen earthen structures after the 1994 Northridge Earthquake in Los Angeles. This case study illustrates a successful approach to dealing with site form and complexity. The time frame of the overall project was limited by the instability of the structure and consequent risk to public safety. Due to the short time frame, fast recording tools were selected, including photography, videography, hand measurement, and hand drawings. The time spent at each site was prioritized according to “the overall schedule, size, and significance of the structure, degree of damage, and complexity of the failure patterns.”⁹³

93 Anthony Crosby, “Rapid Assessment,” in *Recording, Documentation, and Information Management for the Conservation of Heritage Places: Illustrated Examples*. Rand Eppich and Amel

A contrasting method used for another GCI project was the recording of the intricate and irregular surfaces of the adobe wall system at Tambo Colorado in Peru. A high level of detail was necessary for this project so a 3D laser scanner, requiring highly trained personnel, was used to record the surface geometry of the wall system. Other technologies, such as GPS and digital photography, were also used during the project. This multi-faceted approach addressed the limitations of the large (13 km), complex site that was characterized by multiple features of varying complexity and scale. The data was then used for multiple purposes including extracting measurements and recording surface conditions.⁹⁴

Time Frame

As described above, GCI's *Recording, Documentation, and Information Management for the Conservation of Heritage Places* includes time frame as an important consideration for selecting recording methods and tools. *3D Laser Scanning for Heritage* also notes that some tools gather data more quickly, for example digital photography recording information within seconds while 3D laser scanners require a substantial amount of time.⁹⁵ The time frame for fieldwork can be determined by project budgets as well as emergency or risk to the heritage object.

Risk to Object

Undertaking heritage recording can gather data that is used to identify, analyze or evaluate the level and type of risk that faces a heritage object or site. This can help determine solutions for eliminating, controlling or mitigating immediate or

Chabbi ed. (Los Angeles: J. Paul Getty Trust and the Getty Conservation Institute, 2008), 17.

94 Eppich et al. ed. *Recording, Documentation, and Information Management*, 31 – 42.

95 *3D Laser Scanning for Heritage* (English Heritage, 2007), 7.

long-term hazards or deterioration phenomena.⁹⁶ In cases where a large amount of data is required in a short time frame for high-risk projects (such as structural deformation of a dam or bridge that would lead to failure), 3D laser scanning might be appropriate. Slow cracking of an adobe wall that is not endangering the public might require less costly or complex tools such as photogrammetry.

Cost and Cost Benefit Analysis

Very few sources deal directly with the issue of cost. The aforementioned discussions on scope, site form and site complexity indirectly address it by indicating that labor and tools used during the project should match the level of detail required for the larger purpose of the documentation project, therefore reducing cost. However, many examples exist where a low level of detail is an unavoidable condition of resources limited by geography and personnel, not necessarily cost or importance. While sources do not list situations that would justify cost, a review of case studies reveals that it might be advisable to allocate a large budget for documentation projects if: the site is of great significance with a high risk of loss; a site's failure is a significant risk to public safety; data can be used for more than one purpose (for example conditions mapping and measured architectural drawings). It is even more important to clarify justifiable reasons for large-spending when considering most preservation organizations are non-profit or government organizations. These generally operate on limited budgets and use public funds and any significant amount of money spent on unnecessary high levels of recording for low-risk sites is not justifiable.

96 García et al. ed., *Theory and Practice on Terrestrial Laser Scanning*, 13.

Monitoring

Criteria for Creating a Monitoring Program and Selecting Appropriate Tools

There are many different motivations for undertaking a monitoring program of cultural heritage sites or objects, ranging from providing information for sustainable planning, to risk assessment, to measuring long-term rates of decay.⁹⁷ Regardless of the reason for undertaking a monitoring project, it should be used to confirm a hypothesis regarding the diagnosis of a problem rather than to create a hypothesis.⁹⁸ This will determine what type of information the monitoring method is required to gather and will therefore dictate what monitoring tools should be used. The following discussion will focus on the standards and objectives related to measuring long-term rates of decay as the purpose of this thesis seeks to answer the question: is 3D laser scanning a viable tool for monitoring and quantifying stone surface deterioration?

Because monitoring requires recording information over a given period of time, there are a few general principles that must be followed to ensure that the data gathered will be meaningful and useful over the whole monitoring time period. First, there should be long-term durability, reliability and accuracy of all tools used during the monitoring process. Second, the tools selected should be either simple or guaranteed against obsolescence. Third, both the methodology and tools should be efficient in order to reduce error.⁹⁹

In addition to the general recording principles described above, the following discussion outlines specific criteria for monitoring which must be

97 Michael C. Henry, *Technical Note: Monitoring, Interpretation and Use of Data* (Los Angeles: J. Paul Getty Trust, 2003): 1.

98 Ibid.

99 Henry, *Technical Note: Monitoring, Interpretation and Use of Data*, 3.

considered when planning a monitoring program and selecting monitoring tools. The criteria include: sampling resolution, accessibility of the subject, the subject's form and complexity, the project time frame, method repeatability, error and accuracy, visual representation of data, and cost. The tools must be evaluated according to these principles to determine if they will achieve the project objectives.

Sampling Resolution

Sampling resolution is the increment between each measurement. The resolution should be smaller, or finer, than the object's rate of change in order to capture the change. This requires the smallest measurement increment necessary for successfully interpreting the data to be identified. It will be dependent on the goals of the monitoring process as well as the subject's attributes.

When applied to 3D laser scanning, the sampling resolution (the distance between points or point cloud density) should be smaller than the rate of change in order to detect differences between scanning intervals.¹⁰⁰ If the goal of the monitoring project is to determine the recession rate of stone, the selected 3D laser scanner must have the ability to collect data points at densities smaller than the recession rate and have a sufficient tolerance between the level of error of the collected data and the required resolution. If the goal of the monitoring project is to determine gross deformation of large objects over a longer period of time, a larger resolution can be used. Typical ranges for sampling resolutions are outlined in Table 1. It is imperative that the required scanning resolution is calculated during the initial planning phase of the monitoring program as different scanners will capture information at different resolutions.

¹⁰⁰ The actual number for the resolution increases as the value for the resolution decreases, e.g. 7mm is a lower resolution than 2mm.

Site Accessibility, Form and Complexity

Access to the site, as well as its form and complexity will help determine the nature of the monitoring program. As illustrated in the recent publication, *Recording, Documentation, and Information Management for the Conservation of Heritage Places: Illustrated Examples*, the scale of the monitoring program for weathering phenomena at a vast and remote site would be different than that for a small building in an urban environment.¹⁰¹ The monitoring method is also usually focused on the most significant or valuable characteristics of the site and therefore need to be able to capture information site-specific information.¹⁰² Finally, the condition of the subject will determine whether the monitoring method should be destructive or non-destructive.

3D laser scanning is considered a non-destructive monitoring method and is well suited for friable or fragile subjects. Accessibility to the site will determine which type of laser scanning technology to use (triangulation, time-of-flight, or lidar) as each operates within different distance ranges. Additionally, each has different resolution capabilities that should capture the site-specific information without capturing too much data, which would potentially encumber the post-processing process.

Timeframe

The project timeframe, available staff, and tool availability will determine how quickly the information needs to be gathered and the minimum allowable interval between scanning sessions. This minimum interval will be a function of the

101 Eppich et al. ed., *Recording, Documentation, and Information Management*, 2008).

102 Tony Walton, *Department of Conservation Technical Series 27: Methods for Monitoring the Condition of Historic Places* (Wellington New Zealand: Department of Conservation, 2003), 8.

scanner's resolution capabilities and the project timeframe.

Each laser scanner has the capability of capturing information at different rates and a scanner should be selected which can conform to the appropriate speed. In general, finer point densities require longer scanning sessions. When using time-of-flight scanners, the speed at which the scanner captures information is also determined by the "number of shots," or the number of times each point is taken. Increasing the number of shots per point increases the accuracy, but slows the speed of data capture. It is also important to note that the number of shots beyond 25 is unlikely to significantly impact the accuracy of the data.¹⁰³

Measurement Repeatability

Because monitoring programs are intended to capture information (usually changing conditions) over a pre-determined timeframe, each measurement, which is a "single point" observation, must be able to be repeated. This requires both an instrument and methodology that provide consistent and repeatable measurements at the established level resolution and tolerance.¹⁰⁴

If 3D laser scanning is used, there are several levels at which the process must be repeated. At the smallest level, each measurement shot of a point is considered a single observation. At the next level each shot is averaged to determine the position of the point.¹⁰⁵ Then, each point is grouped into a point cloud for one scan and each scan is then registered during the post-processing phase to form the complete point cloud. All steps occur within a single scanning

103 "Scan Parameters," *PointScape 4.0 Help*, Trimble.

104 Henry, *Technical Note: Monitoring, Interpretation and Use of Data*, 2 – 3.

105 The number of shots for each point is averaged and the discrepancies between measurements are expressed as a standard deviation. The standard deviations of all points within a single scan are then averaged to create a single standard deviation for the entire scan.

session. While the complexity of this layered measurement system makes it unlikely that each single measurement will be repeated exactly, the sum of a scan session must be accurate enough to be repeatable. This is accomplished by having geo-referenced point clouds of different periods which can be compared. Geo-referencing requires permanent targets on or around the subject for the entire monitoring interval. These must be established at the beginning of the project; they should be resistant to weathering and changes in temperature so as to be in the same global coordinate system throughout the project. There are two issues concerning permanent targets: 1) is introducing permanent targets to a heritage site practical (for example if the substrate of the site is changing, as in earthen structures, or if the site is in a seismic zone) and 2) is it within best practices to introduce permanent features at a heritage site? If the impact of creating permanent targets cannot be reversed, they would be considered destructive, effectively changing 3D laser scanning from a non-destructive to a destructive tool.

Error and Accuracy

Error occurs in all measurement and functions as an indicator of the accuracy of the collected data. Error is either random or systematic and can come from many sources, including the measurement instrument, the object being measured, the measuring methodology, the operator or the environment.¹⁰⁶

As described above, 3D laser scanners are complex tools with different layers of measurement. They are therefore susceptible to sources of both random and systematic error at every level. It is important to remember that while each shot is a single measurement and is subject to error, only cumulative error for

106 García et al. ed., *Theory and Practice on Terrestrial Laser Scanning*, 32.

the scan is reported by the scanner and post-processing software. Therefore, not only is error compounded throughout the scanning and registration processes, but it is also not possible to calculate the error of specific points, thus making the accuracy of the data uncertain. Cumulative error may be reduced by:¹⁰⁷

- carefully understanding manufacturer specifications in order to select an appropriate laser scanner type and model
- researching continuing studies of accuracy tests of laser scanners
- correctly calibrating the device according to changing environmental factors (such as air density)

However, the most successful way of reducing error is to minimize it during the data collection process by having a well planned methodology for collecting data. It is also important to note that if the scanning work is outsourced to a private contractor, the end user should communicate the appropriate tolerance for error and ask for error and environmental condition reports.

Similar to the generally accepted sources of error described above, four error categories are defined in *Theory and Practice* (García et al. ed., 2008). They include instrumental, object-related, environmental, and methodological errors.¹⁰⁸ Table 2 outlines potential error sources in 3D laser scanning. One potential benefit is that the automatic sampling that the laser scanner performs provides an objective, and therefore more accurate, data set.¹⁰⁹ However, because a resolution is selected during the planning process, which effectively determines the level of sampling, and because it is usually necessary to select

107 ibid.

108 ibid.

109 David M. Barber, Ross W.A. Dallas and Jon P. Mills. "Laser Scanning for Architectural Conservation" *Journal of Architectural Conservation* 12, no. 1 (March 2006): 49.

specific features of the subject to sample in order to reduce the overall file size of the content, accuracy as a result of automatic sampling is not universal.

Visual Representation of Data

The way in which data is visually represented affects how the information will be interpreted by the end user. Once the information is gathered, it must be presented in such a way that it answers the questions the monitoring program set out to achieve. The representation should also clearly communicate such information so that it will be correctly interpreted and utilized by the end user.

The data acquired by 3D laser scanners is able to be processed by highly specialized software that is designed to extrapolate information directly from point clouds. Products that can be generated from point clouds using such software include profiles or sections of the subject, cloud-to-cloud comparisons (to determine differences or changes), and topographic or intensity-based models. In addition to providing technical information, laser scanners appear to be well suited for conditions mapping on complex 3D subjects because they have the potential for reducing misrepresentations that occur when rendering a 3D object in 2D.

Yet the issue of communicating both the technical findings as well as the conditions in 3D must still be addressed. As mentioned by English Heritage, “While the point cloud generated by laser scanning may be useful on its own, it is more than likely that the cloud will be a means to an end rather than the end itself.”¹¹⁰ Software that specializes in processing point clouds is designed for technical analysis rather than providing visually descriptive information and other software is usually necessary. Although

110 *3D Laser Scanning for Heritage* (English Heritage, 2007), 7.

modeling software continues to improve, point cloud data remains large and cumbersome for most software applications to process (which is again why it is important to not gather more information than necessary). Therefore, visual representation using point clouds is constrained by 1) the cost of software, which is more fully explained below 2) the ability of existing hardware and main-stream modeling software to handle the large file sizes 3) time spent creating the representation 4) the target audience (whether the visual data is should be highly technical so it is usable to conservators, or whether it is intended for general education purposes). In addition, if the 3D information is reproduced in a 2D format, such as a written report, the benefits of the information in 3D is lost.¹¹¹ This means that the user remains limited by how he or she can work with and communicate using the data

Cost

As Henry points out, “the best method is not necessarily the method that yields the most accurate information. The best method may be the one that provides useful information at an appropriate cost.”¹¹² Cost is a serious constraint of most monitoring projects; tool selection will be determined by cost and available time.

The cost of 3D laser scanners and specialized post-processing software is at the top of the price range of available monitoring and measurement tools, such as tape measures, photogrammetry or total stations. The price is dependent upon scanner type and manufacturer as well as whether the equipment is purchased, rented or the scanning and post-processing is outsourced to a contractor. It is noted in several sources that scanning reduces project costs

111 Barber et al.. “Laser Scanning for Architectural Conservation,” 48-49.

112 Henry, *Technical Note: Monitoring, Interpretation and Use of Data*, 5.

although there is serious discrepancy and confusion in the literature regarding this issue. There are conflicting viewpoints on whether scanning reduces the cost of post-processing time.^{113 114} A reduction in fieldwork time is also both implicitly and explicitly equated to a reduction in cost.^{115 116 117} Assuming that the operator is highly efficient and experienced, laser scanning might reduce data collection time in the field, especially if the subject is at a remote site or requires scaffolding for access. It might also improve safety when working in dangerous or unstable sites, which could reduce unforeseen costs.¹¹⁸ High costs may also be offset if the data is used for multiple purposes, for example calculating structural deformation while also capturing measurements to be used for architectural drawings for both architecture and conservation teams. Further more, the technology is thought to be more accurate and achieve higher resolution than other monitoring tools, which raises the two questions: is the increased accuracy and resolution necessary and what is the value of such increased accuracy and resolution? However, no definite cost analysis on the use of laser scanning in heritage preservation has been performed to date. Therefore, it has not been determined that these potential benefits are actually cost saving.

While scanning potentially reduces time in the field, except for the discrepancy mentioned above, it is generally accepted that the data requires

113 English Heritage points out that laser scanning is not universally accurate or complete for every object at a low cost, nor is it necessarily a quick solution [English Heritage, *3D Laser Scanning* 2007, 7], while other sources provide examples of projects where 3D laser scanning was a cost effective method [Barber et al. "Laser Scanning," *JAC* 12, no.1 (March 2006): 47 – 48].

114 Karen E. Hughes and Elizabeth I. Loudon, "Bridging the Gap: Using 3-D Laser Scanning in Historic-Building Documentation," *APT Bulletin* 36, no. 2/3 (2005), 38.

115 Hughes et al., "Bridging the Gap," 38.

116 García et al. ed., *Theory and Practice on Terrestrial Laser Scanning*, 15.

117 Barber et al., "Laser Scanning for Architectural Conservation," 50.

118 Barber et al., "Laser Scanning for Architectural Conservation," 45.

significant post-processing time. Post processing time is particularly dependant on the complexity of the final deliverable. Each scan must be registered and geo-referenced, and noise and gaps in the point cloud must be removed. Additionally, point cloud processing software has analysis tools but to create drawings the point clouds must be imported into computer-aided drafting software (such as AutoCAD) and the drawings must be created manually by tracing the edges of the point cloud. Therefore, post-processing not only requires time but also facility with each software application. This aspect either accrues cost in the form of time spent learning how to work with the point clouds or money spent outsourcing the project. Additionally, because a monitoring program requires the process to be repeated in order to capture changing conditions, the costs will be multiplied. Therefore, using 3D laser scanners for monitoring cannot simply be justified by saving time in the field, but the total cost for each project must be calculated according to the nuances of the project, the requirements for accuracy and resolution, and the capabilities of the team.

Summary of Standards and Objectives for 3D Laser Scanning

There are several advantages of laser scanning that appear throughout the literature. These include non-contact (non-destructive) measurement, high accuracy, long range accessibility and fast data acquisition.¹¹⁹ Yet the above criteria produce several critical implications for the use 3D laser scanning in heritage preservation. First, 3D laser scanners are complex tools that require a high degree of skill for their operation and data interpretation. Their complexity exposes them to error from many sources and it is important to know potential sources of error in order to prevent their interference in the quality of data.

119 García et al. ed., *Theory and Practice on Terrestrial Laser Scanning*, 15.

Additionally, because their complexity requires specialized knowledge for operation, it also increases purchasing, rental or outsourcing fees. There are a variety of ways to limit these costs. In addition to those discussed above, one potential way is to limit the overall data capturing timeframe while maintaining high resolution and high accuracy by carefully selecting what features must be scanned to meet the project objectives. As eloquently written by Barber et. al, “a skill of the operative is in setting the right balance between detail and economy.”¹²⁰ This crucial factor reinforces the importance of creating a monitoring program with specific aims that seek to prove a hypothesis, rather than to arbitrarily capture all of the information at the site.

These criteria also raise the issue of what outcomes or deliverables can be achieved by 3D laser scanning. In order to determine whether the cost justifies the means, it is important for the end user to know exactly how the scanned data can be used and whether they will have the capabilities of utilizing the information “in-house” or whether it requires special outsourcing to trained professionals. As mentioned throughout this discussion 3D laser scanning has been proven to achieve the following:

- Monitoring of macro-deformation or change of buildings and sites, especially for life-risk assessment or total loss of the site.¹²¹
- Large scale base-line recording at remote sites¹²²
- Small scale base-line recording at both remote and accessible sites.^{123&124}

120 Barber et al., “Laser Scanning for Architectural Conservation,” 36.

121 García et al. ed., *Theory and Practice on Terrestrial Laser Scanning*, 2008.

122 Eppich et al. ed., *Recording, Documentation, and Information Management*, 37 – 42.

123 *3D Laser Scanning for Heritage* (English Heritage, 2007), 26.

124 Harriet F. Beaubien, Basiliki Viciy Karas, and William W. Fitzhugh, “Documenting Mongolia’s Deer Stones: Application of Three-Dimensional Digital Imaging Technology to Preservation,” in *Scientific Research on the Sculptural Arts of Asia: Proceedings of the Third Forbes Symposium*

- Fine resolution models for replication.¹²⁵
- Architectural drawings.

Using 3D laser scanning for long-term recording of complex, small-scale subjects at a fine resolution has not been proven. Nor are there examples of using scanned data to map conditions of 3D subjects in 3D. These are both frequently required in preservation yet there is no literature either from the heritage field or from the laser scanning industry that demonstrates that it is possible to use 3D laser scanning for these purposes. This reveals that there are limited applications for 3D laser scanning and heritage professionals should be aware of these limitations.

In addition to limited applications, because the cost of laser scanning is higher than most other forms of documentation and monitoring, yet achieves the same results, the question is raised whether laser scanning is an appropriate tool for small, non-profit or governmental organizations that rely on public funding. Furthermore, if money is disproportionately allocated to monitoring, then cost constraints are placed on other aspects of the preservation process, such as stabilization or conservation.

As English Heritage notes, “another technique may be able to provide the information required” and the issue of laser scanners really distilled to a cost-benefit analysis for each specific project.¹²⁶

at the Freer Gallery of Art, ed. Janet G. Douglas, Paul Jett, and John Winter (Washington DC: Freer Gallery of Art, Smithsonian Institute, 2007), 133 – 142.

125 *3D Laser Scanning for Heritage* (English Heritage, 2007), 20-23.

126 *3D Laser Scanning for Heritage* (English Heritage, 2007), 3.

Chapter 4) Test Case

Condition Survey

In 2008 the National Park Service commissioned the University of Pennsylvania Architectural Conservation Laboratory to undertake a condition survey of the two lions flanking the east side of the Merchants' Exchange Building in Philadelphia, Pennsylvania.

The lions are carved from Pennsylvania Blue Marble and are exhibiting exfoliation and disintegration (Appendix A). The Merchants' Exchange Building was designed by William Strickland and built between 1832 and 1834 to house the financial transactions of the Philadelphia. The lions were a gift to the city from John Moss and carved by Signor Fiorelli. They were copied from Canova's lions in the tomb of Pope Clement XII at Saint Peter's in Rome. They were removed from the Merchants' Exchange to the Philadelphia Art Museum in 1922 and were returned to the Merchants' Exchange in 1965.¹²⁷

Due to the three dimensional and highly curvilinear nature of the lions, three dimensional laser scanning was selected as the tool that was most likely able to capture the complexity of their form and provide a data set from which to work. This approach would also provide an opportunity to test the usage of 3D laser scanning for condition assessment as well as provide an opportunity for evaluating the tool's general performance in heritage preservation. The specific advantages of 3D laser scanning were thought be:

- Capturing and rendering information in the Z axis.
- Providing an integrated source for all conditions information.
- Increased accuracy due to the combined benefits of the above two factors.

The lions are each 84"(l) x 36"(w) x 36"(h) and are located on top of

¹²⁷ *Merchants' Exchange Building*, National Historic Landmark Nomination Form, 5-9.

twenty foot high platforms (Appendix A). Due to their size and height of their position, access is limited. Project costs did not include funding for scaffolding, which would be necessary for close-range triangulation scanning. Therefore, the Trimble GX laser scanner, a mid-range, terrestrial time-of-flight scanner was select because it could access the lions from a distance. Fieldwork took place from June 9th to June 14th. During this time the team received training on planning for a scanning project, assembling and operating the hardware and software in the field, collecting the data and post-processing.

Table 4: Specifications for the Trimble GX 3D Scanner¹²⁸

Measurement Type	Time-of-flight
Laser Class	Class 2, Green Color
Range	350m @ 90% reflective surface
Field of view	60 ° vertical 360 ° horizontal
Reference Target	Spherical or flat targets placed on or around subject
Standard Deviation (standard data captured from four shots of same measurement point)	1.4mm @ ≤ 50m 2.5mm @ 100m
Accuracy of Single Point Measurement	Position = 12mm @ 100m Distance = 7mm @ 100m
Minimum Resolution (distance between points)	3mm @ 100m
Beam Divergence (diameter of laser point footprint)	.9mm@15m 1.5mm@25m 3mm @ 100m
Maximum Scan Rate	5.0 pt/s
LCD Camera	Integrated
Scanner Software	PointScape
Proprietary Post-Processing Software	RealWorks Survey 6.3

128 Trimble, *Trimble GX 3D Scanner Data Sheet*, Trimble, http://www.trimble.com/trimblegx_ds.asp.

Data Collection

Because the goal of acquiring data was for a condition survey, which would require a large amount of post-processing, it was decided to scan the lions at a 2mm resolution in order to capture a sufficient level of detail but not create an unusable data set. Appendix A illustrates the scan station set-up relative to the lions. In order to capture information from multiple angles relative to the lion and to avoid obstructions of the laser path, some station positions required placing the scanner on a high-lift. While data from at least five scan stations was captured for each lion, as will be discussed below only the data from some of the positions was usable. However, the total data acquisition time for each lion was approximately eight hours, which included setting up and dismantling the equipment, training and practicing, and collecting the data. However, the first set of data for the north lion had extreme levels of error and the team was required to re-scan the lion, which took an additional 4 hours. The team was able to monitor the error levels of the data by registering each scan using target-to-target registration in the field. This ensured that accurate data was being collected and appropriate registration errors were being met.

Significant problems arose during the scanning process:

- Environmental temperatures above the specified temperature range of the laser scanner.
- Changing temperatures, humidity and air density throughout the day (across scans).
- Changing temperatures during individual scans (for several scans, the scanner recorded a 2°C increase from the start of the scan to the end)
- Removal of a critical registration target.
- Movement of a critical registration target.
- Objects obstructing the line-of-sight of the laser, including trees and the Merchants' Exchange Building.
- Limited timeframe.

After each scan was registered, the final mean residual registration error for

Fig. 7: Modeling the Lions: Workflow

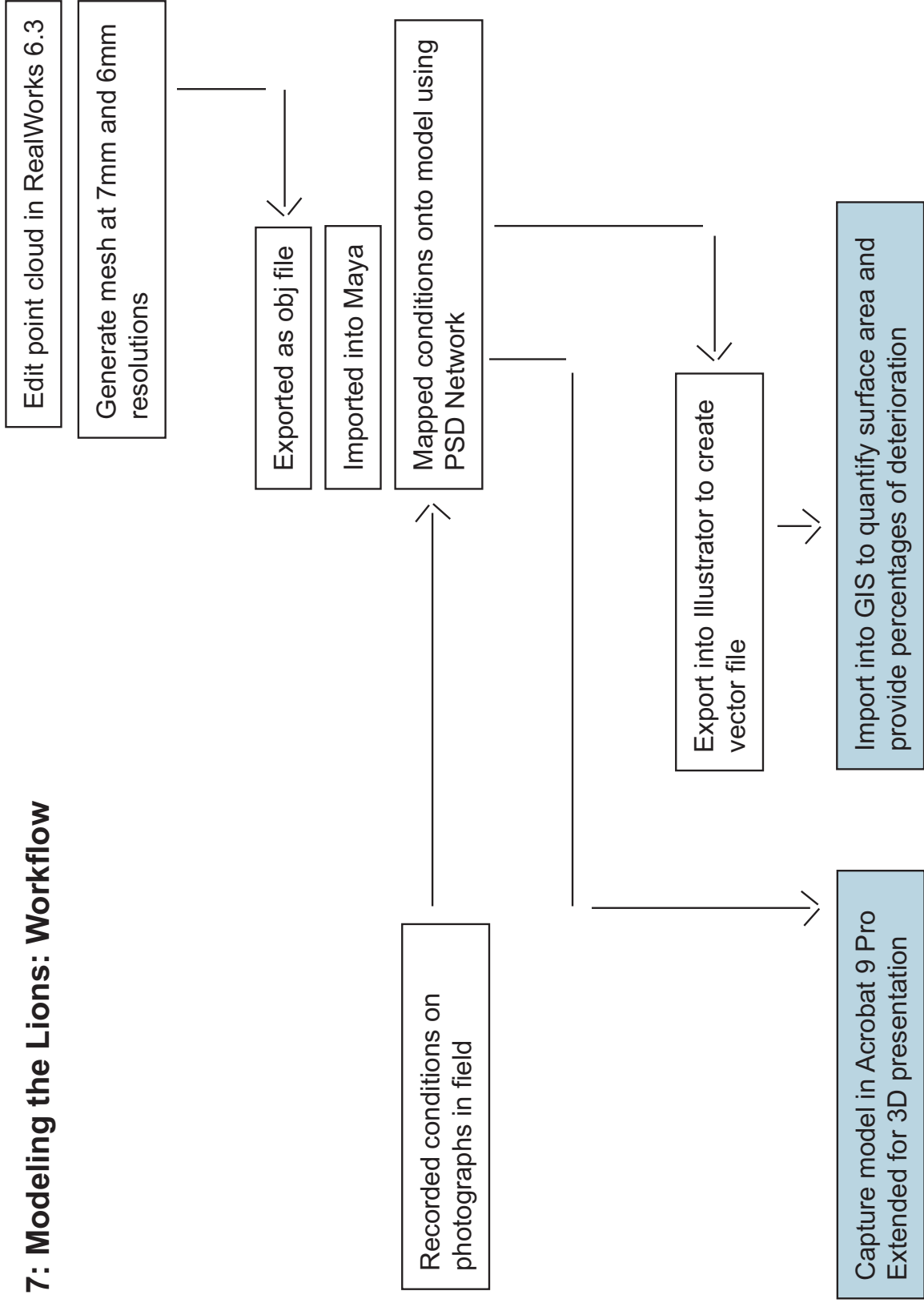

the south lion was .71mm and 1.89mm for the north lion. Table 2 outlines the potential sources of error and how they might have affected the residual registration error.

While changing temperatures and air density were compensated for by the GX scanner's *real time thermo-compensator* and *atmospheric correction calibrator*, it is possible that such temperature fluctuations caused dimensional change of objects during individual scans as well as across scans. For example, one of the targets was placed on a steel beam at 3.2 m above grade and was scanned throughout the day and used as a critical registration target. Such a beam will expand lengthwise. If the temperature of the beam increased by 10°C, which while not measured is possible as mornings were cool and temperatures then reached well above 40°C around 3pm. The following equation is applied to see if this temperature increase had an effect on registration errors:

Linear coefficient of thermal expansion of $11.7 \times 10^{-6} \text{ mm/mm/}^\circ\text{C}^{129} \times 10^\circ\text{C}$ on a
3.2 m (3200mm) beam = .37mm.

This increase is within the range that is statistically significant for what will affect the registration errors of .71mm for the north lion and 1.89mm for the south lion.

The scanner has some integrated controls but the magnitude of the environmental conditions during the data collection process might have affected the accuracy of the emitted laser, increased the registration residual error because there was dimensional change of the substrates on which targets were placed (such as metal poles), and finally caused the scanner to crash. Additionally, the lost and displaced targets compromised the registration of several scans. The effects not only decreased overall quality of the data, but

129 Edward Allen and Joseph Iano, *Fundamentals of Building Construction, 4th Ed.*, (Hoboken, New Jersey: John Wiley & Sons, Inc, 2004), 870.

the scanner crashing and the necessary rescanning of the north lion increased fieldwork time. Further more, a tree close to the back of the south lion precluded scanning the back side, resulting in an incomplete south lion. As noted above, the team rescanned the north lion to collect higher quality data, however, due to the limited timeframe the south lion was not able to be rescanned and the residual error after registration is higher than that of the north lion.

Lessons Learned

Planning

It is essential to carefully plan the placement locations of each target. The targets should be placed on temperature-resistant surfaces and with limited access to accidental movement by people or objects. Because each scan requires three targets to execute target-to-target registration, placing four to seven targets in each scan frame increases the probability for accurate registration.

Performing Registration in the Field

Undertaking target-based registration in the field allowed the team to gauge the quality of data as it was acquired. This enabled the team to identify unsatisfactory results and repeat scans as necessary, increasing the quality of the data.

Flexibility

The terrestrial scanners are not light-weight, inexpensive pieces of equipment. They are heavy, cumbersome, and require a moderate amount of setup. Due to their bulk and price, they cannot be operated in awkward positions beyond the different tilt positions the neck and tripod base can produce. For example, they cannot be cantilevered over the subject without extreme risk to the scanner.

Therefore, while terrestrial scanners are considered to increase accessibility to inaccessible sites, they can only do so from substantial distances in stable positions and cannot easily access the top surfaces of subjects.

Time

While laser scanning does capture measurement points much faster than manual techniques (the Trimble GX can capture up to 5000 points per second), the dilemma of accuracy versus time remains. Carefully planning target locations and equipment set up increase field time. Capturing data at high resolutions and rescanning poor quality scan increases field time. The failure of scanners and computer equipment increases field time. Thus, laser scanning is not a “point and shoot” solution. It requires careful training, careful setup, and a significant amount of time if the project requires high levels of resolution and accuracy.

Post-Processing: Workflow

Once the data was collected and registered, research began on how to use the point cloud data for a conditions survey. The goal was to record the conditions on 3D digital model and used those recorded conditions to visually represent decay phenomena and accurately quantify surface deterioration.

Fig. 7 illustrates the final post-processing workflow that will be used and Table 5 in Appendix B illustrates what software applications were considered and how they responded to the evaluation criteria.

Identification and selection of software for consideration was primarily guided by whether or not the program could process point clouds. The second criteria was the ACL’s access to the software; does the ACL already have access to the computer program, is there access to a demo-version of the program, or will it

be required to buy the software? Finally, software identification was guided by both cost and the general ubiquity of software within the laser scanning and heritage fields. The goal was to find a solution that has practical application; that can be used by preservation organizations without substantial investment or expense.

It was determined that RealWorks Survey 6.3, which was purchased by the ACL as an all-purpose application for processing point clouds, has the greatest capabilities for editing and meshing the point cloud. Maya was then selected as the best program for representing conditions because the software 1) is accessible to the ACL, 2) has the ability to render surface information, 3) has the ability to interact with ubiquitous programs such as Photoshop and Acrobat, 4) is increasingly used in the design field, and 5) has a relatively moderate cost compared with more boutique or obscure software applications.

Once the modeling software was selected, the following questions shaped the remainder of the investigation:

- Question 1: What was the maximum workable resolution?
- Question 2: Can the conditions be recorded directly onto the digital models, or is it necessary to record them on photographs and then transfer the conditions onto the digital models?
- Question 3: Once conditions are recorded, can they be layered onto one model, or do they need to be represented on each of their own models?
- Question 4: Can the method of representing surface conditions be used quantitatively?

Findings for Question 1: Resolution

Each lion was scanned at a resolution of 2mm and initially had approximately 1.2 million points per lion. The point cloud was then re-sampled and cleaned to X number of points. The point cloud was then meshed at a 7mm resolution, which was the maximum workable resolution within the workflow.

	Raw Point Cloud	Mesh Resolution	# of Triangles in Mesh	File Size (MB)
North Lion	1.6 million points	7mm	500,000	27.5
South Lion	830,000 points	6mm	400,000	23

Findings for Question 2: Recording Conditions

Attempts were made to record conditions directly on the digital models in the field, however this was found to be impracticable. First, rendering surface textures in Maya is a delicate process that requires a stable station setup because it entails accurate mousing (precluding use of the touchpad) and manipulating (rotating and zooming) the model view. Second, working with large, complex meshes in Maya is at the limits of the software’s capabilities. Because the program has a high potential for crashing and losing data, recording conditions directly on a digital model significantly increases risk for data loss and resulting increased fieldwork time. Third, laptops are somewhat heavy and it is usually necessary to have mobility and flexibility for observing conditions. It was impractical to carry the computer in one hand, mouse in other, and try to move around the subject. Fourth, sun severely decreases visibility of the computer screen and thwarts the recording process. Because recording must take place at the immobile subject, the recorder is subject whatever climate presents itself. Because using a computer is really only possible in dry, cloudy conditions or in shade, the reality of field-working conditions make its use very restricted. Using a Tablet PC would not have significantly increased the flexibility of this approach, however scaffolding around each lion might have allowed the conditions to be recorded. It should be noted, however, that this would have significantly

increased project costs.

As an alternative, conditions were recorded using the traditional method using photographs, Mylar sleeves, and color coded pens. The conditions were then transferred onto the model in the lab. This was a much more effective solution, however it raises the question: why not use 2D photographs if they are the fundamental source of information for the 3D model? One argument could be that it increases the accuracy of quantifying the conditions if the quantification includes information in the Z axis. However, there is inherent inaccuracy when recording in 2D and transferring to 3D because the Z axis conditions are only recorded and assembled through different 2D views; the potential for missing information in the Z plane remains. A second argument is that conditions mapped onto the 3D model assembles the information in one source and reduces the need to reference information, such as between photographs. This is true, however because the process is so expensive, the user must determine the monetary value of having all the information in one place.

Question 3: Layering Conditions

The conditions can be layered in Photoshop however it is best to use solid shading as it renders better on the model in Maya. This limitation is a consequence of Photoshop as raster-based program, which produces images that are less linear and more pixilated than those of vector-based programs. Thus the challenge is to determine the maximum number of conditions and the fill pattern that can be represented on the subject while imparting clear, visual information.

Question 4: Quantification

The surface information can be used quantitatively by opening the Photoshop

image into Illustrator, converting it into vector shape files, and opening the file in GIS for analysis. The result is the percent coverage of conditions relative to the whole surface (Appendix A). However, problems arise when working between photoshop files as they sometimes differ in the “total area” of the lion.

Post-Processing: Debunking Presumptions

“Draping Photos”

It is often believed that 3D models generated from point clouds can be enhanced and made more life-like by draping photos over them. This can be done either manually or automatically, depending on whether or not the laser scanner has an integrated or external camera. The manual method requires the operator to manually adjust the model in the screen view so that it is in the same position as the camera view of the photograph; then the draping function can be executed. This is an extremely inaccurate and time consuming approach for complicated subjects, such as the lions, but is feasible for flat surfaces, such as building facades. The automatic approach requires photographs that are registered with the scanned model; these photographs are usually generated by the scanner during the scan cycle. This approach is much more accurate and less time consuming, however it performed by point-cloud specific software (such as RealWorks 6.3) and is limited by the resolution capabilities of the integrated cameras. As an example, most of the images captured by the GX scanner were very pixilated and most were inadequate for texturizing the lions. Furthermore, the results produce shadowed streaks on the areas that the photographs do not depict the draping process only renders information in the XY plane, not the YZ plan (Fig. 8).

Fig. 8: Draping Photos



It is possible to stitch and blend the photographs to minimize this, but the results still do not produce high-quality images. Additionally, the process would still be relying on 2D photographs to depict surface information.

Capturing Color

Many 3D laser scanners are equipped with *real-time integrated color* capturing capabilities. These features capture the color value of each point as it scans. However, a serious dilemma is that they only capture the color of the subject in the condition that it is scanned. This is problematic if the subject is partly in shadow (Fig. 9), which misrepresents the true color of the subject. Therefore, the color that the scanner captures is not reliable color information.

Fig. 9: Shadow Color Captured as True Color by Laser Scanner

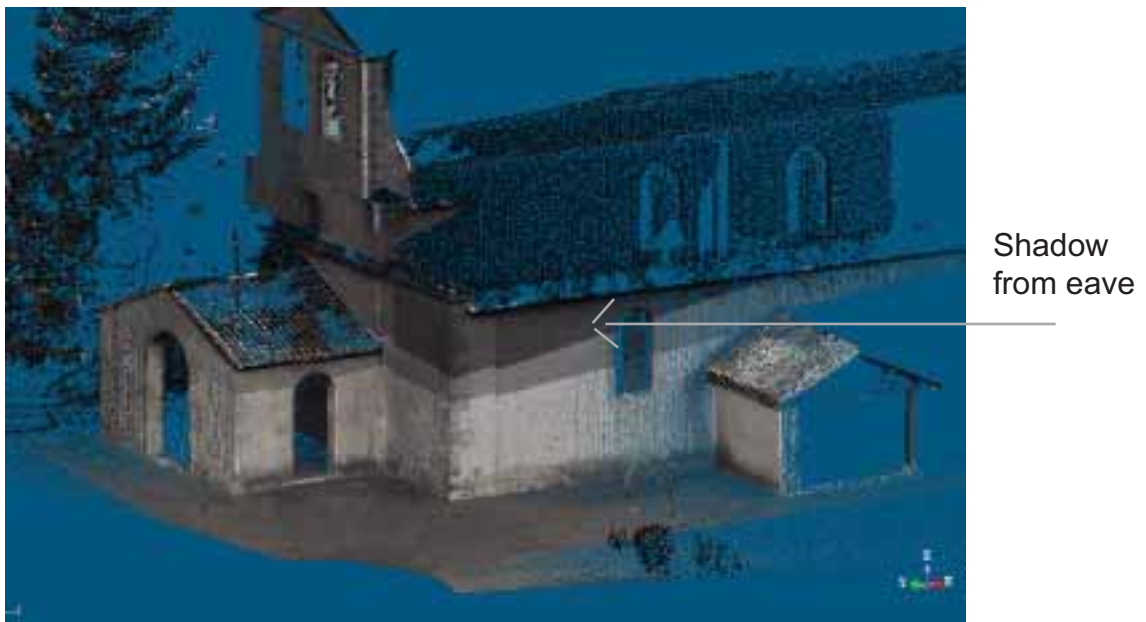

(A Cathedral, Source: R. Larry Holtgreive and Keystone Precision Instruments)

Loss of Resolution

In order to texturize the mesh in Maya, the resolution of the point cloud must

be reduced to a level so that the finite capacity of the software and hardware (including RAM and graphics card) can process the commands. This reduces the surface texture. The loss of resolution is generally considered to be undesirable in the laser scanning field where resolution and accuracy are treated as the two most important features of laser scanning methods. Yet however desirable high resolution is, ultimately the data must be usable for heritage conservation. As discussed in Chapter 2, there limited number of uses of point cloud data. If the data's resolution must be reduced in order to expand the usefulness of the data, such as for a conditions survey, then there must either be a paradigm shift that accepts the decrease in surface texture, or the implemented scanning method must currently be considered unacceptable because the data is not useful beyond the uses discussed in Chapter 2. The scanning method could then be reformatted to achieve acceptable results (for example, taking high-resolution scans in fewer and selective areas so that the software and hardware can process the information) or a different tool could be used to meet the project objectives. In this test case, reduction in resolution was considered acceptable in order to render the surface conditions on the subject and extract quantitative information.

Accuracy

There has been substantial discussion thus far on the accuracy of the single point measurements as well as problems with determining and controlling for the accuracy of the entire point cloud data set. However, if in order to be usable the resolution of the point cloud must be reduced, the question is raised: is the resulting data set accurate enough to justify the cost of the laser scanning equipment, post-processing software, and labor? It should also be noted that when the model is "cleaned" (the resolution is simplified, overlapping geometries

are deleted, and the meshed surface is smoothed), it is impossible to tell which points are being deleted: noise or accurate measurement points. This process further decreases the accuracy of the collected data, which indicates that the most accurate use of point cloud data is in its raw form.

Testing the efficacy of recording conditions directly on the digital model in the field also explored the accuracy dilemma. Because the conditions survey method of recording directly on the digital model failed, a series of 2D photographs were used instead and the conditions were rendered onto the digital model. This is more of a quasi-3D approach to conditions mapping because the basis for the information is still 2D. Additionally, rendering the conditions in the Z plane is not more accurate in this approach because they were not originally captured in the Z plane. Rather, this approach enables the conditions information to be consolidated and integrated into one model, which does not increase *accuracy* but rather creates a new mode of *representation*. So if this process does not increase accuracy, what is the monetary value of having an integrated digital conditions survey? This has frequently been achieved through orthophotographs and CAD-based conditions quantifications methods. Finally, complications arose when recording dimensional loss on the 3D model because it cannot be rendered on the scene background, as would be possible in a 2D format.

A Weakness of Modeling

Undertaking metric survey using 3D laser scanning is certainly more accurate than measured hand drawing and is usually more accurate than other surveying and monitoring methods. However, because it seeks to produce fancy images in addition to metric information, investigation into the quality of representation and whether that representation is suitable for heritage sites is warranted. It is argued

that the “feeling” of an object cannot necessarily be captured by the most modern survey tools.¹³⁰

In a case study of survey methods at the Church St. Valentin in the South Tyrol, Italy, the team used both hand drawings as well as digital metric survey devices. They contended that in order to capture the maximum amount of information about the subject, a more detailed, thoughtful, and qualitative approach was necessary than could be provided by the metric survey devices alone.¹³¹ They therefore undertook hand drawings of important elements to capture more descriptive information (Fig. 10).

Fig. 10: Comparison between a Hand Drawing and a Point Cloud

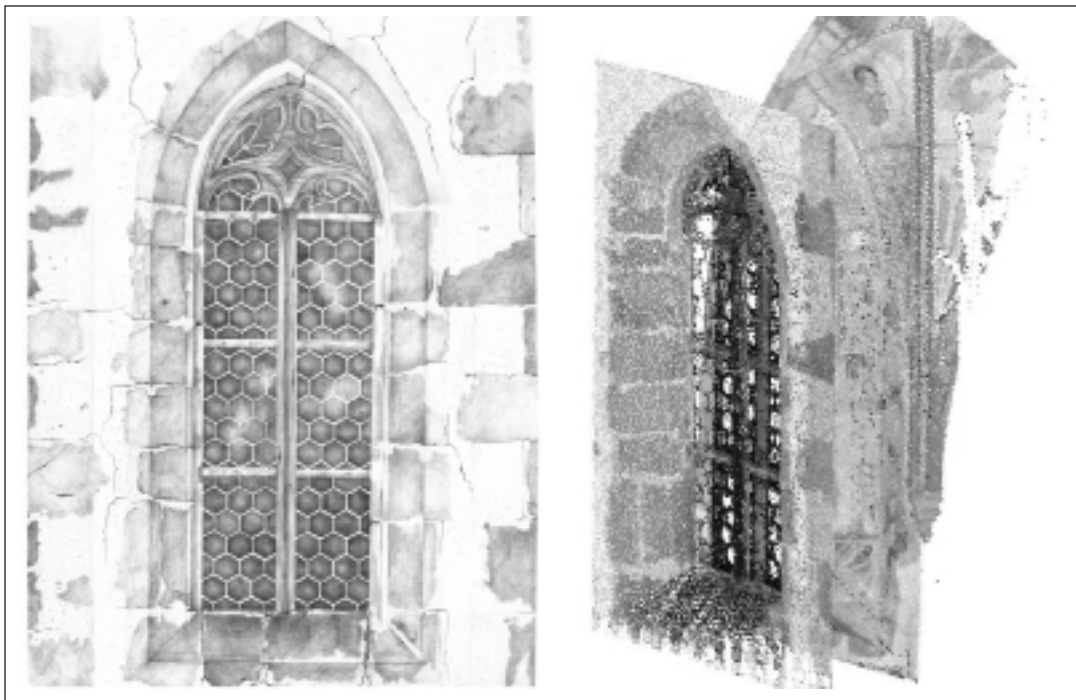

(Burger, “A Combination of Modern and Classic Methods,” 3.)

130 A. Burger et al., “A Combination of Modern and Classical Methods of Surveying Historical Buildings- The Church St. Valentin in the South Tyrol” (paper presented at XXI International CIPA Symposium, Athens, Greece, October 1-6, 2007).

131 Ibid.

This philosophy can be applied to the use of 3D laser scanners as these devices attempt to supply both quantitative metric information and qualitative descriptive information about the subject's surface. As noted above, color and registered photographs are not necessarily reliable features of 3D laser scanners, precluding their use for treating the surface of the model and imparting descriptive information. The texture of the meshed surface is also not a reliable mode as the resolution must sometimes be reduced to make the data usable. Therefore, the remaining option is to render surface information using computer-aided drafting applications (such as Maya). However, during this test case it became apparent that there are limitations within the capabilities of CAD programs. The primary limitation was based upon the Maya's reliance on interpreting the model as simple and repeating shapes. Appendix B illustrates the differences between the shapes and textures of images created in Maya and 2D representations. Additionally, the coloring options of the surface are raster-based, and do not provide clean outlines or hatchings, as with using 2D vector programs such as autoCAD.¹³² Models developed in Maya exhibit none of the naturalism that is the essence of the lions. Two dimensional etchings and photographs are able to capture this information. While CAD modeling applications are very powerful, it requires an immense level of 3D design computer skills and the best products are usually produced by entire teams in highly lucrative movie and visual design industries. While heritage professionals must be adept with developing digital technologies, what is the level reached where it is beyond what is relevant to conservation.

132 Documentation and *Conditions Survey of the Exterior Marble Masonry of the Second Bank of the United States, Philadelphia, PA* (Philadelphia: University of Pennsylvania ACL, July 2004).

Printing and Disseminating 3D Information

Three dimensional information usually must be viewed on a computer, because the 3D information is changed into a 2D format if it is printed on paper (such as for a report). This can be achieved if the information is integrated into a website or if the user has a viewing program (usually provided by the same company from which the model was created). Recently, Adobe released Acrobat 9 Pro Extended, which allows 3D models in many CAD applications to be “captured” by Adobe Acrobat and incorporated into PDF documents and presentations. Because Acrobat Reader is pervasive and free, this is a significant development in disseminating 3D information. Unless the 3D information can be viewed in a digital format, printed using a 3D Printer, or used for quantitative analysis and then interpreted using discrete means (such as charts or graphs), it loses much of its three dimensional advantages. Furthermore, there are no standards for recording or disseminating three-dimensional information in the preservation field. HABS standards do not permit submittal of 3D information to the Library of Congress and there are no national archiving standards for digital 3D information.¹³³

Conclusions

The final deliverables could include mapped conditions on a 3D model as well as quantification of conditions relative to the whole surface. While a final 3D model with mapped conditions is achievable, the conclusion of the study found

133 Department of the Interior, National Park Service, *HABS Guidelines*, National Park Service, <http://www.nps.gov/hdp/standards/habsguidelines.htm>

the 3D model to be visually unsatisfactory and the cost is not offset by increased accuracy or time. However, because there are no other documented attempts, there is still potential for further investigation, especially for uses as a diagnostic tool.

Monitoring

After the data was gathered and there was further investigation into the use of 3D laser scanners in heritage preservation, the question was raised: what sort of project parameters would have been necessary to use 3D laser scanning for monitoring sub-millimeter surface loss of the lions. Repeatability and resolution (point cloud density) are the two factors that affect monitoring at the micro scale. They are influenced by the limitations of the scanner type as well as the allotted project period. The two essential determinations to make are the rate of change that must be captured and the time period that will fulfill the project objectives.

Required point cloud resolution and period between scans are both functions of the recession rate of marble in central Philadelphia. Therefore, there are two approaches to evaluating the efficacy of a methodology for monitoring recession. The first approach establishes the required point cloud resolution according to the maximum practical time interval between scanning sessions (usually defined by the project schedule). The second approach defines the minimum interval between scans according to the resolution limits of the equipment. In either approach, the annual recession rate is required:

$$\text{Recession (mm)} / \text{Time (yrs)} = \text{Annual Recession Rate (mm/yr)}$$

In the first approach, the required resolution is determined:

$$\text{Required Resolution (mm)} = \text{Maximum Practical Period Between Scans (yrs)} \times \text{Annual Recession Rate (mm/yr)}$$

In the second approach, the Minimum Required Interval Between Scans is determined:

Minimum Required Interval Between Scans (yrs) = Smallest Available Resolution
(mm)/ Annual Recession Rate (mm/yr)

For example, the mean recession rate for marble in central Philadelphia in 1985 was determined to be 3.5 mm/ 100 yrs and <0.5 mm/ 100 yrs. While pollution concentrations (a significant causative factor of marble weathering) decreased in the Philadelphia region over the period of investigation, Feddema and Meierding indicate that the locations with the highest pollution concentrations had not changed.¹³⁴ Due to the general trend of decreasing pollution levels in the Philadelphia region, it can be assumed for this exercise that the current mean recession rates in central Philadelphia are still within 3.5 mm/ 100 yrs and <0.5 mm/ 100 yrs. Therefore, it is an appropriate rate from which to determine the minimum necessary resolution level for current micro-surface deterioration.

$$\begin{aligned} 3.5\text{mm}/100\text{yrs} &= .035 \text{ mm/ year} \\ <0.5 \text{ mm/ } 100 \text{ yrs} &= .005 \text{ mm/ year} \end{aligned}$$

A comparison of different laser scanners commercially available shows that highest resolution (which is the smallest dimensional value between points in the point cloud) capability of most laser scanners is achieved by close-range triangulation scanners with maximum resolutions of .016mm, but most achieve resolutions of .05mm.

134 J.J. Feddema and T.C. Meierding, "Marble Weathering and Air Pollution in Philadelphia," *Atmospheric Environment* 21, no. 1 (1987): 143 – 151.

Table 6: Assessment of Required Intervals between Scans as a Function of Recession Rates and Point Cloud Resolutions

Scanner Type	Point Cloud Resolution (mm)	Recession Rate of Marble (mm/yr)	Relative Speed of Recession Rate	Minimum Interval between Scans (yrs)	Total Δ in Resolution (mm) from Lowest Point Cloud Resolution (.016mm)	Increase in Minimum Interval from Lowest Point Cloud Resolution (.016mm)
Triangulation	.016	.035	Fast	.5	---	---
Triangulation	.016	.005	Slow	3.2		
Triangulation	.05	.035	Fast	1.5	.034	3x
Triangulation	.05	.005	Slow	10		
Triangulation	.9	.035	Fast	26.5	.85	18x
Triangulation	.9	.005	Slow	180		
Time-of-Flight	2	.035	Fast	57	1.95	40x
Time-of-Flight	2	.005	Slow	400		

* Highest resolution capability found for 3D laser scanners (specifications from *Metris ModelMaker MMD50* at operating range of 50mm or .1m)¹³⁵

This analysis raises several areas of concern. First, achieving a practical interval between scans relies on data with virtually no error that is collected in extremely controlled conditions with scanners that have highest resolution and

135 Metris, "ModelMaker Scanners," Metris http://www.metris.com/handheld_scanners/modelmaker_d/

accuracy capabilities commercially available. It is likely that accuracy and resolution will decrease with other scanners or variable scanning conditions. Second, .05mm resolutions reflect the scanners' accuracy levels at very close operating ranges (.1 - 1m), but accurate resolution decreases as the operating range increases, thus increasing the interval.

The substantial change in the minimum interval between scans demonstrates that even minor amounts of error that slightly decrease the resolution and accuracy of the data, can substantially alter the required period between scans. Additionally, the term "sub-millimeter accuracy" is frequently used in the laser-scanning field. However, it should be noted that the .9mm resolution in the above calculation was still within a "sub-millimeter" level, yet it would require an unfeasible period between scanning sessions to register change.

Furthermore, due to the sensitivity and requisite close operating ranges of triangulation-based scanners, they function optimally in very controlled environments and have significant limitations for outdoor fieldwork. In view of the numerous potential sources of error outlined in Table 2, if 3D laser scanning is to be used for monitoring sub-millimeter losses for large, complex, dimensional objects or buildings, particularly in an outdoor context, the following limitations must be overcome:

- Sensitivity of hardware to influences by heat or other environmental factors.
- Corrections for thermal movement of the subject must be applied to the final scan data.
- Permanent registration and geo-referencing targets must be installed for the duration of the monitoring period. These targets cannot be affected by thermal expansion and contraction, erosion, displacement, and removal.
- Assurance that the hardware, software, and data file-types do not become obsolete during monitoring period.

Test Case Summary

While the results of the condition survey revealed that quantification of surface conditions is possible, it was found that other comparable methods could achieve equal accuracy regarding quantification while also producing more elegant, informative results at higher resolutions. While investigating the use of 3D scanning for monitoring was not initially part of the project parameters, the hypothetical scenario created for the purpose of investigation provided great insight into the limitations of the scanner hardware and scanning process for capturing surface erosion with point cloud resolutions above .05mm, especially for marble recession rates lower than .035 mm/yr. Additional difficulties arise when considering the numerous sources of error that are introduced into the scanning process.

However, once satisfactory data is captured, tools are available for determining micro-scale change between point clouds. Currently, there are two primary methods of comparing scan data: cloud-to-cloud surface comparison (not to be confused with cloud-to-cloud *registration*) and profile or section comparisons. Comparing surfaces of point clouds from different time periods can be achieved if the point clouds are geo-referenced within the same coordinate system. For example, Trimble RealWorks 6.3 has a *twin surface inspection tool* which compares two surfaces of the point cloud, an *inspection map tool* to compare the point cloud with simple planar and cylindrical shapes, and the ability to create profiles for analysis in computer aided drafting software applications. Therefore, 3D laser scanning might be utilized for localized monitoring of very slow surface weathering in close-range applications, provided that hardware and environmental error issues are addressed.

Final Conclusions

Two interconnected issues surround the efficacy of using 3D laser scanning for conservation purposes in heritage preservation: cost and practicability.

Three dimensional laser scanning methods were originally developed for quality control in the manufacturing of industrial parts because they can create a greater volume of measurements, more quickly, and with higher accuracy than other measurement techniques. Additionally, the point cloud data can interact with computer aided drafting software for designing parts through reverse-engineering and manufacturing those parts using numerical control machines. In this type of application, 3D laser scanners have multiple uses, as well as the additional benefit of being a cost saving tool because of its increased accuracy and speed. Therefore, despite the fact that they are relatively expensive, laser scanners are cost effective in these applications because the data can have multiple uses and because the cost of mistakes in large-scale manufacturing is greater than the price of the tool. In other words, the savings out-weighs the costs. As in manufacturing, if 3D laser scanners are to be used for heritage preservation purposes, they need to continue to be a cost-effective technique for the decisive goal of preserving cultural objects.

Extensive research reveals that there are very limited applications for using laser scanning in heritage preservation. The most common (structural monitoring, generating working drawings, and baseline recording) can all be achieved using multiple and usually less expensive means. Therefore, if 3D laser scanning is going to be cost-effective, the point cloud data must have a variety of uses. The test case of the lions at the Merchants' Exchange, which sought to expand the

use of point cloud data, demonstrates that there are serious practical limitations for using the data in monitoring loss of surface deterioration at the micro-scale. The test case also revealed both practicable limitations and further expense when developing the point cloud data into a usable and versatile 3D model for conditions survey and analysis. Furthermore, imbibed in modeling is the issue of aesthetics. Even very clean, high resolution models assume a plastic quality and lose much of the natural character of the subject. If the intent of the model is to communicate information but the modeling process fundamentally distorts this, it is not a successful method for effectively disseminating that information.

Potential alternative methods using point cloud data in conservation include collecting small samples of point cloud data for analysis and then using alternate ways to communicate the findings, such as through charts and graphs. Laboratory testing for determining weathering rates might be more successful due to the highly controlled environment. As mentioned in Chapter 2, using the point cloud as a referencing model for a database would allow the incorporation and cataloging of high-resolution photographs, physical descriptions, and treatment history. This would be particularly useful for long-term or large-scale conservation projects because it would facilitate storage and dissemination of information between larger numbers of conservators over longer periods of time. However, problems would still exist regarding resolution and accuracy capabilities of the instruments, as well as time and expense.

While there are important and valid uses for 3D laser scanning in many fields, in heritage preservation it continues to be a cumbersome and expensive process. If the ultimate purpose of monitoring and recording conditions is to preserve the

subject, and the chosen tool not only minimally achieves these goals, but is also so expensive that it diverts funds from the conservation of the subject, then it should be approached with caution. Three dimensional laser scanning should therefore only be used when it is demonstrated that the resulting data will be usable and is a cost-effective method for satisfying the final objectives of the preservation project.

Bibliography

Aerial Archive. "Introduction to Photogrammetry." Aerial Archive at the University of Vienna. <http://www.univie.ac.at/Luftbildarchiv/wgv/intro.htm> (accessed April 22, 2009).

Albertz, Jörg. "Albrecht Meydenbauer: Pioneer of Photogrammetric Documentation of the Cultural Heritage." *Proceedings from the XVIII International CIPA Symposium, Potsdam, Germany, September 18 – 21, 2001*, 19 – 25.

Allen, Edward and Joseph Iano. *Fundamentals of Building Construction*. Hoboken, New Jersey: John Wiley & Sons, Inc., 2004.

Almagro, Antonio. "Simple Methods of Photogrammetry: Easy and Fast." *Proceedings from the XVIII International CIPA Symposium, Potsdam, Germany, September 18 – 21, 2001*, 32 – 38.

American Institute for Conservation of Historic & Artistic Works. "Commentary 24: Documentation." In *Commentaries to the Guidelines for Practice of the AIC*, 1996, <http://aic.stanford.edu/pubs/comment24.html>.

Aust, W.M., A. Azola, and J.E. Johnson. "Management effects on erosion of Civil War military earthworks." *Journal of Soil and Water Conservation* 58, no. 1 (2003): 13 – 20.

Barber, David M., Ross W.A. Dallas, and Jon P. Mills. "Laser Scanning for Architectural Conservation." *Journal of Architectural Conservation* 12, no. 1 (March 2006): 35 - 52.

Barnett, T., A. Chalmers, M. Diaz-Andreu, G. Ellis, P. Longhurst, K. Sharpe, I. and Trinks. "3D Laser Scanning for Recording and Monitoring Rock Art Erosion." *International Newsletter on Rock Art (INORA)* 41 (2005): 25-29.

Beaubien, Harriet F., Basiliki Viclcv Karas, and William W. Fitzhugh. "Documenting Mongolia's Deer Stones: Application of Three-Dimensional Digital Imaging Technology to Preservation." In *Scientific Research on the Sculptural Arts of Asia: Proceedings of the Third Forbes Symposium at the Freer Gallery of Art*, edited by Janet G. Douglas, Paul Jett, and John Winter. Washington DC: Freer Gallery of Art, Smithsonian Institute, 2007.

Bell, Stephanie. "A Beginner's Guide to Uncertainty of Measurement." In *Measurement Good Practice Guide No. 11* (Issue 2), (March 2001).

Bratasz, Łukasz, Romon Kozłowski, Dario Camuffo and Emanuela Pagan. "Impact of Indoor Heating on Painted Wood: Monitoring the Altarpiece in the Church of Santa Maria Maddalena in Rocca Pietore, Italy." *Studies in Conservation* 52 (2007): 199 – 210.

Brizzi, M., S. Court, A. d'Andrea, A. Lastra, and D. Sepio1. "3D Laser Scanning as a Tool for Conservation: The Experiences of the Herculaneum Conservation Project." *The 7th International Symposium on Virtual Reality, Archaeology and Cultural Heritage VAST* (2006).

Burger, A., A. Grimm-Pitzinger, and E. Thaler. "A Combination of Modern and Classic Methods of Surveying Historical Buildings: The Church St. Valentine in the South Tyrol." Paper presented at the XXI International CIPA Symposium, Athens, Greece, October 1 – 6, 2007.

Chang, J.R., K.T. Chang, and D.H. Chen. "Application of 3D Laser Scanning on Measuring Pavement Roughness." *Journal of Testing and Evaluation* 34. no 2. (March 2006), 83 – 91.

Crosby, Anthony. "Rapid Assessment." In *Recording, Documentation, and Information Management for the Conservation of Heritage Places: Illustrated Examples*, edited by Rand Eppich and Amel Chabbi. Los Angeles: J. Paul Getty Trust and the Getty Conservation Institute, 2008.

Eppich, Rand and A. Chabbi, ed. *Documentation and Information Management for the Conservation of Heritage Places: Illustrated Examples*. Los Angeles: J. Paul Getty Trust and The Getty Conservation Institute, 2007.

Eppich, Rand, Francois LeBlanc, English Heritage Technical Survey Team, Divay Gupa, Peter Waldhausl, Robin Letellier, José Luis Lerma, and John Hurd. *Documentation for Conservation: A Manual for Teaching Metric Survey Skills*. CIPA- RecorDIM, 2007.

Hughes, Karen E. and Elizabeth I. Loudon. "Bridging the Gap: Using 3-D Laser Scanning in Historic-Building Documentation." *APT Bulletin* 36, no. 2/3 (2005).

Jacobs, Geoff. "3D Scanning: Understanding Spot Size for Laser Scanning," *Professional Surveyor Magazine* (October 2006), <http://www.profsurv.com/magazine/article.aspx?i=1720>, (accessed April 14, 2009).

Fitzner, B., K. Heinrichs, and R. Kownatzki. "Weathering forms: classification and mapping." In *Natursteinkonservierung in der Denkmalpflege*, edited by B. Fitzner, H. Ettl and L. Sattler. Munich: Bayerisches Landesamt für Denkmalpflege, 1995.

García, José Luis Lerma, Bjorn Van Genechten, Erwin Heine, and Mario Santana Quintero, ed. *Theory and Practice on Terrestrial Laser Scanning Training Material Based on Practical Applications, Version 4*. Valencia, Spain: Universidad Politécnica de Valencia, June 2008.

Grissom, C. A., A.E. Charola, M.J. Wachowiak. "Measuring Surface Roughness on Stone: Back to Basics." *Studies in Conservation* 45, no. 2, (2000).

Gupta, Divay. *Identification and Documentation of Built Heritage in India*. New Delhi: INTACH, 2007.

Henry, Michael C. *Technical Note: Monitoring, Interpretation and Use of Data*. Los Angeles: J. Paul Getty Trust, 2003.

High, C. and F.K. Hanna F.K. "A Method for the Direct Measurement of Erosion of Rock Surfaces." *Brit. Geom. Res. Crp., Tech. Bull.* 5, (1970).

Klieger, Paul and Joseph F. Lamond. *Significance of Tests and Properties of Concrete and Concrete-making*. ASTM International, 1994.

Kwong, A.K.L., L.G. Tham, and B.A. King. "Application of 3D Laser Scanning Technique to Slope Movement Monitoring." *Journal of Testing and Evaluation* 33, no. 4 (July 2005): 266 – 273.

Leach, Peter. *The Surveying of Archaeological Sites*. London: Institute of Archaeology Publications, 1988.

Letellier, Robin. *Recording Documentation and Information Management for the Conservation of Heritage Places: Guiding Principles*. Los Angeles: J. Paul Getty Trust and The Getty Conservation Institute, 2007.

Maish, Jeffrey. "Silicone Rubber Staining of Terracotta Surfaces." *Studies in Conservation* 39, no. 4 (Nov., 1994): 250 – 256.

Maish, Jeffrey and Erik Risser. "A Case Study in the Use of Cyclododecane and Latex Rubber in the Moulding of Marble." *JAIC* 41, no. 2 (2002): 127 – 137.

Matero, F.G. and J. Peters. "Methods for Monitoring the Condition of Historic Places." *APT Bulletin* 34, no. 2/3 (2003) 37 – 45.

National Park Service. "HABS Guidelines." National Park Service, US Department of the Interior. <http://www.nps.gov/history/hdp/habs/index.htm> (accessed April 22, 2009).

Oliver, Anne. "A Preservation Action Plan for Fort Union." *CRM* no. 10 (1997): 13-15.

Padgett, A. *Assessment of Deteriorative Factors Affecting the Inscriptions, El Morro National Monument, New Mexico, Report for the National Park Service*. Philadelphia: University of Pennsylvania Department of Historic Preservation, 1992.

Park, Seung-Kyu, Sung- Hoon Baik, Hyung-Ki Cha, and Yong-Moo Cheong. "Laser Ultrasonic Inspection System with a 3D Surface Profilometry to Detect Surface Cracks." *Modern Physics Letters B* 22, no. 11 (2008).

Principles for the Recording of Monuments, Groups of Buildings and Sites. Ratified by the 11th ICOMOS General Assembly, Sophia, Bulgaria, October, 1996.

Robson, Stuart and Spike Bucklow. "Conserving the Westminster Retable." University College, London.

Smith, D.I. "The Micro Erosion Meter: Its Application to the Weathering of Rock Surfaces." Paper presented at the International Workshop on the Conservation of Rock Art, Perth, Australia, September, 1977.

Smith, R.A. *Smith's Illustrated Guide to and through Laurel Hill Cemetary*. Philadelphia: W.P. Hazard, 1852.

Stanbridge, Rory. "Photogrammetry- A Practical Guide." In *The Building Conservation Directory*. United Kingdom: Cathedral Communications Limited (1995, article updated 2005), <http://www.buildingconservation.com/articles/photogram/phtogram.htm>.

Thornes, Robin and John Bold. *Documenting the Cultural Heritage*. Los Angeles: The J. Paul Getty Trust, 1998.

Tmjillo-Schiaffino, Gerardo, Nicolas Portillo-Amavisca, Didia P. Salas-Peimbert, Laura Molina-de la Rosa, Saul Almazan-Cuellar, and Luis F. Corral-Martinez. "Three-dimensional Profilometry of Solid Objects in Rotation." Paper presented at RIAO/OPTILAS 2007.

Trudgill, S.T., H.A. Viles, R. Inkpen, C.Moses, W. Gosling, T. Yates, P. Collier, D.I. Smith, and R.U. Cooke. "Twenty-Year Weathering Remeasurements at St. Paul's Cathedral, London." *Earth Surface Processes and Landforms* 26 (2001): 1129-1142.

Understanding Historic Buildings: A Guide to Good Recording Practice. English

Heritage, 2006.

Understanding the Archaeology of Landscapes: A Guide to Good Recording Practice. English Heritage, 2007.

Walton, Tony. *Methods for Monitoring the Condition of Historic Places*. Wellington: Department of Conservation, 2003.

Winkler, E.M. "A Macrostereogrammetric Technique for Measuring Surface Erosion Losses on Stone." In *Cleaning Stone and Masonry: ASTM Special Technical Publication 935*, edited by James R. Clifton, 153 – 161. Philadelphia: American Society for Testing and Materials, 1986.

Winkler, E.M. "Stone Weathering: A Rebuttal." *APT Bulletin* 19, no. 3 (1987): 3

Winkler, E.M. and M. Kirchmayer. "Weathering of Crystalline Marble at the Field Museum of Natural History, Chicago." *APT Bulletin* 23, No. 4, (1991): 43-47.

With Alidade and Tape: Graphical and Plane Table Survey of Archaeological Earthworks. English Heritage, 2002.

Where on Earth Are We? The Global Positioning System (GPS) in Archaeological field survey. English Heritage, 2003.

Zaimes, G.N., R.C. Schultz, and T.M. Isenhardt. "Stream bank erosion adjacent to riparian forest buffers, row-crop fields, and continuously-grazed pastures along Bear Creek in central Iowa." *Journal of Soil and Water Conservation* 59, no. 1 (2004): 19 – 27.

Appendices

<i>Appendix A: The Lions at the Merchants Exchange</i>	98
<i>Appendix B: Evaluation of 3D Laser Scanning and Point Cloud Data</i>	106
<i>Appendix C List of Vendors</i>	112

APPENDIX A: THE LIONS AT THE MERCHANTS' EXCHANGE

MERCHANTS' EXCHANGE HISTORICAL COMPARISON

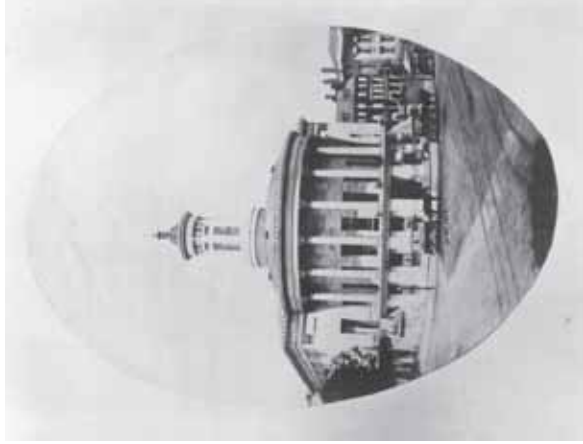

Merchants' Exchange, 1869 Source: NPS



Merchants' Exchange, ca. 1930 - 1940
Source: NPS



Merchants' Exchange, 2009 Source: Jessica Kottke

NORTH LION HISTORICAL COMPARISON



North Lion, ca. 1960 Source: NPS



North Lion, 2008 Source: Jessica Kottke

SOUTH LION HISTORICAL COMPARISON



South Lion, ca. 1960 Source: NPS



South Lion, 2008 Source: Jessica Kottke

CONDITIONS GLOSSARY: LIONS OF THE MERCHANTS' EXCHANGE

DISCOLORATION/ DEPOSIT



Encrustation

Formation of gray to black particulate deposits in protected areas that are noticeably more concentrated than the prevailing soiling patterns.



Micro-biogrowth

Colonization of biological material such as thin biofilms, fungi and lichens, with hyphae that can cause the stone to break apart.



Soiling

Adhesion of pollutants from the atmosphere, water, guano or human activities. The intensity can be determined by the degree and strength of the soiling particulate.



DETACHMENT



Sugaring

Loss of material from the breakdown or cleaving of the individual grains along grain-to-grain boundaries.



Contour scaling

Detachment of larger, platy material parallel to the stone's surface. The decay intensity can be determined by comparing the size and thickness of the scale or scale stacks relative to the original stone material and to flaking.



Flaking

Detachment of small, thin stone elements along the profile of the stone; a smaller form of contour scaling. The larger quantity and frequency of smaller sized flakes and their individual thickness is the characteristic differentiating between contour scaling and flaking.



Incipient Spalling

Detachment of material that is dependent on the stone structure and the materials' orientation within that structure. This can occur in the presence of contour scaling or without contour scaling.

LOSS OF SUBSTRATE MATERIAL



Microkarst

Network of small interconnected millimeter to centimeter depressions, exhibiting patterns similar to hydrographic networks.

PREVIOUS TREATMENTS

Coatings

Presence of a coating on a stone surface, generally off-white, gray, or pale yellow in color.



Dimensional loss

Localized stone loss greater than two square inches in area and at least 1/2 inch in depth



Filled cracks

A mortar or resin based system for filling cracks.

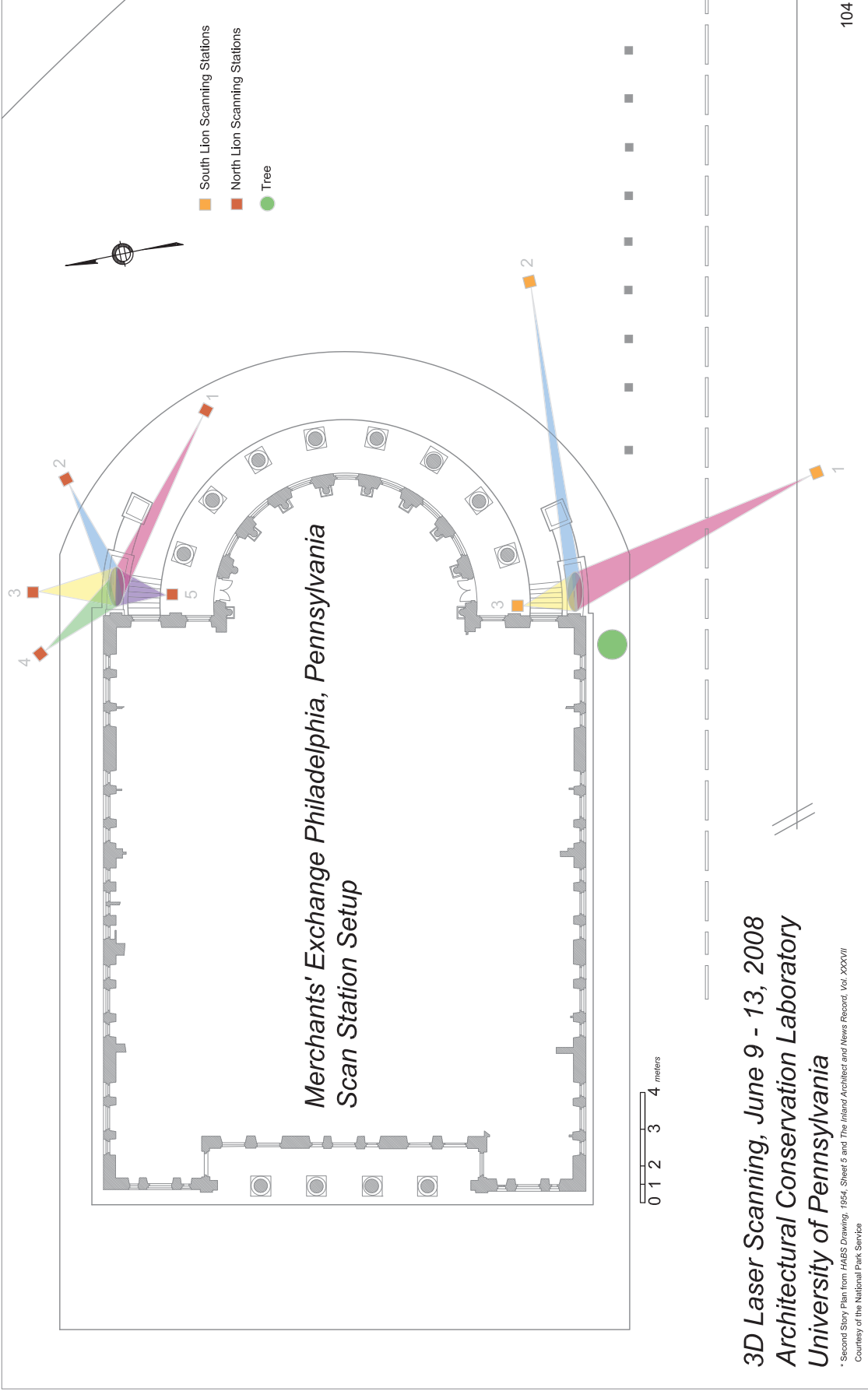

3D Laser Scanning, June 9 - 13, 2008
Architectural Conservation Laboratory
University of Pennsylvania

* Second Story Plan from HABS Drawing, 1954, Sheet 5 and The Inland Architect and News Record, Vol. XXXVII
 Courtesy of the National Park Service

EXAMPLE OF MODEL OF NORTH LION AND QUANTIFIED CONDITIONS

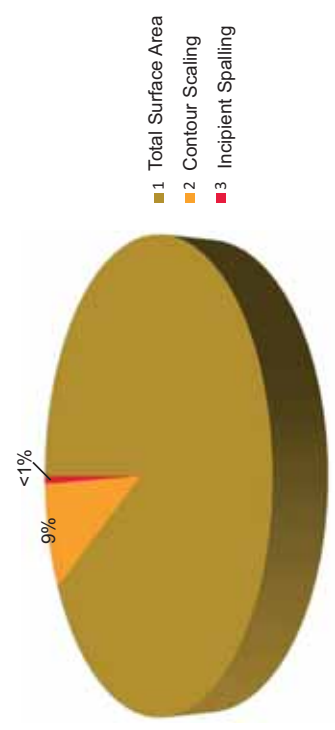
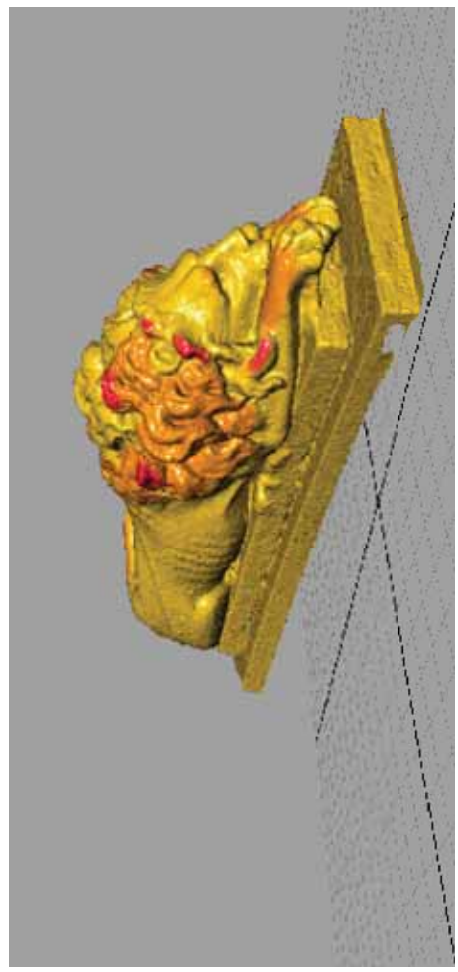

APPENDIX B: EVALUATION OF 3D LASER SCANNING AND POINT CLOUD DATA

Lions



TABLE 2: SOURCES OF ERROR IN 3D LASER SCANNING AND POTENTIAL EFFECTS ON TEST CASE

Error Categories	Sources of Error	Cause of Error	Description	Result of Error	Trimble GX Specifications	Lion Test Case	Potential Effect on Test Case Error
Instrumental							
	Beam Divergence: Positional Uncertainty of the Point Recorded	Spot Size	Uncertainty of where the point is recorded within the footprint of the beam	Systematic error of point accuracy and point cloud resolution	.9mm@15m; 1.5mm@25m	Spot size is 1.2mm@19m	Sample area from which the measurement is taken is 60% of the distance between points (2mm sampling resolution)
	Beam Divergence: Mixed Edge Problem	Spot Size	When a laser beam hits an edge of an object and the beam is split in two. One part of the beam reflects on the closer surfaces while the other part travels further and is reflected off a different surface. The point's position will be calculated based on an average of the different return signals.	The point is incorrectly placed in space and the result is a decrease in the signal – to – noise ratio, indicating greater error in the scan data. This problem is greatest in high resolution scans.	.9mm@15m; 1.5mm@25m	Spot size is 1.2mm@19m	Recording error occurring within 1.2mm along all edges
	Operating Range		Accuracy of the laser scanner at specific distances from the subject.	Each laser scanner is specified to have certain error at different ranges, which must be factored into the cumulative error of the point cloud.	7.6mm@4.3m		
	Angular Accuracy		Consistency in the positioning of the mirrors used to guide the laser signal in a given direction. Inconsistent angles have exponential effects on the position of the laser.	Systematic error of each point measurement.			
	Aligned Axes		All three axes (vertical, collimation and horizontal) must be accurately aligned in order to ensure that the instrument is correctly calibrated so the points of 3D geometrical model are correctly positioned in space.	Systematic error of each point measurement.	Dual-axis compensator		

Lions

Object		Reflective Properties	Object Color	Dark surfaces absorb more of the visible spectrum while light surfaces reflect more of the spectrum. Such surfaces allow the laser to refract and reflect within the material.	Partially absorbed spectra will return a weakened signal Signal – to – noise ratio is reduced.			
			Semi-Transparent Surface of Subject					
Environmental								
	Temperature	Dimensional Change of Subject	Temperatures cause dimensional change of targets and the object recorded. However, because marble heats and cools slowly, this might have a greater effect if the subject is scanned during different seasons (summer vs. winter)	Signal – to – noise ratio is reduced.	Linear Coefficient of Thermal Expansion of Marble: 13 x 10 ⁻⁶ mm/ ^o C increase in temperature	Area of lion in field view of scanner: 2.28m (l) x .9m (h)	+ .3mm (l) x +.12mm (h)	
		Dimensional Change of Target Substrates			Linear Coefficient of Thermal Expansion of Steel: 11.7 x 10 ⁻⁶ mm/ ^o C x 10 ^o C	Steel Pole: 3.2m (h)	+ .37mm	
		Different Temperatures within Scanner	Uneven dimensional change of the scanner or tripod.	Error in scan distance and orientation within space.	0 ^o C to 40 ^o C	2 ^o C above specified operating range on south lion	Manufacturer does not specify the effects of above-range temperatures on scanner	
		Operation of Scanner	If the Temperature exceeds the limits of the scanner, the instrument could potentially shut down.	Loss of data and time.	0 ^o C to 40 ^o C	2 ^o C above specified operating range on south lion	Scanner began crashing with potential loss of calibration	
	Air Density	Different Velocities of Laser Light	The velocity of the laser is the speed at which it travels according to the atmospheric temperature, pressure and humidity.	If the instrument is not correctly calibrated there will be systematic scan distance error. If the air density quickly changes, the velocity will change and the scan distance error will be different for each measurement.				
		Ground Vibrations	Ground vibrations between and during point capture may affect where the beam contacts the subject and at what angle, as well as the position of the scanner when sending the beam.	Random error within each point measurement resulting in a lower signal – to – noise ratio.	Automatic level compensator	From metro, street traffic, industrial lawn mowers	Possibly above range	

	Interfering Radiation		External radiation from strong illumination sources could influence the precision of the returning laser or of how it is recorded.	Random error within each point measurement resulting in a lower signal – to – noise ratio.			
Methodological	Human or Operator Error	Loss of Targets	In ability to perform target-to-target registration	Gross error in completed point cloud.		One target was lost during scanning process	Affected the quality of registration for the south lion
		Incorrect Scanner Selection	Scanner should be able to capture information at appropriate resolution for data processing	In ability to capture necessary data or gross error in completed point cloud.			
	Poor Sampling	Over-sampling, or Undersampling, or Incorrect Sampling	Appropriate and/or representative areas or information was not recorded	Gross error in completed point cloud.			
				Inability to process volume of information			
	Registration Residual Error	Gross Error of Static Scans	Large error in data set precludes the ability to accurately register point clouds using target-to-target registration	Gross error in completed point cloud.	North Lion = 1.89mm South Lion = .71mm		Cumulative error all sources of error during data capture
		Incorrect Hardware Specification	Data sets are so great that computers cannot process the information	Inability to process volume of information			
	Cleaning/ Smoothing of Point Cloud	Inability to Differentiate Between Legitimate Points and Noise	Significant points can unknowingly be deleted	Random error within post-processing procedure which reduces overall confidence level of the data's accuracy			
	Cleaning/ Smoothing of Mesh	Inability to Differentiate Between Legitimate Mesh Faces	Significant faces can unknowingly be deleted	Random error within post-processing procedure which reduces overall confidence level of the data's accuracy	North Lion = 1.89mm South Lion = .71mm		Incorrect points deletion

**TABLE 5:
EVALUATED SOFTWARE FOR POINT CLOUD EDITING, MESHING & MODELING**

	Description	Availability to ACL	Edit Raw Point Cloud Data	Scan Data Comparison	Mesh Point Cloud	Draw Lines on Surface	Texturize Surface with Single Colors	Texturize Surface with Layers of Color	Quantify Surface Information	Cost	Interacts with Ubiquitous Software Applications
Trimble® PointScape™ Software	Proprietary software for Trimble 3D scanners that operates and manages the point cloud data capturing process	Ownership	3	N/A	N/A	N/A	N/A	N/A	N/A	\$\$\$\$	1
Trimble® RealWorks Survey Advanced 6.3.2	Proprietary software for editing, registering, meshing, and executing structural and comparative analysis of point cloud data	Ownership	3	3	2	1	1	1	3	\$\$\$\$	1
Kubit® PointCloud	Proprietary AutoCAD plug-in that allows manipulation and rendering of point clouds	Demo Educational License	N/A	2	N/A	2	1	1	2	\$\$	3
3D MeshLab	Open source software for editing, cleaning, filtering, and texturizing meshes	Online Demo	2	2	2	3	3	1	2	\$	1
GeoMagic® Studio	Proprietary software for point cloud editing, registering, meshing, and modeling	Online Demo	3	3	3	3	3	3	3	\$\$\$\$	1
SYCODE® Point Cloud for Rhino	Free proprietary plug-in for Rhino that generates and edits meshes	Ownership	2	1	2	1	1		1	\$	3
Autodesk® Maya 2009	Proprietary software for editing and modeling meshes	Ownership	3	1	N/A	1	3	3	2	\$\$\$	3
ArcGIS	Proprietary software for analyzing shape files	Ownership	N/A	N/A	N/A	N/A	N/A	N/A	3	\$\$\$	2

Excellent Performance (3) - Poor Performance (1)
 Very Expensive (\$\$\$\$) - Free (\$)
 N/A- Cannot Perform Function

* Evaluation according to the software's performance on the highly curved surfaces of the lions

COMPARISON BETWEEN TYPES OF REPRESENTATION

3D CAD Images: Simplified Shapes and Repeating Patterns



Image courtesy of Massive Entertainment Top, printed in *10 Reasons to Buy Autodesk Maya 2009*, (Autodesk 2009).

Repeating patterns comprise the foliage and buildings. Simplified shapes comprise the plane, buildings, and snow cover.



Image courtesy of Michael Sormann, printed in *10 Reasons to Buy Autodesk Maya 2009*, (Autodesk 2009).

Simplified shapes comprise the machinery and character forms.

Properties of 2D and 3D Renderings



Image: Jessica Kottke 2008

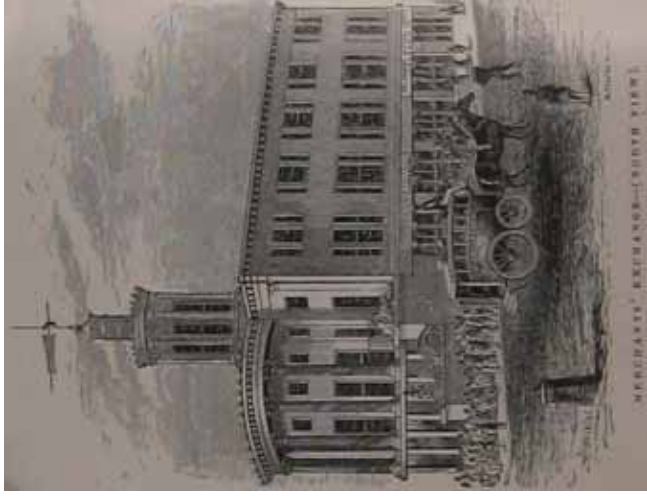

Merchants' Exchange (North View), designed and printed by Brightly, published in Smith's Guide to and Through Laurel Hill Cemetery, Collection of the Fine Arts Library, University of Pennsylvania



Modeled using Trimble RealWorks Survey 6.3

Photograph depicting geometric form, surface texture, color, site context, and natural expression

Etching depicting site context and natural expression

Model depicting diluted geometric form and surface texture

Appendix C:

List of Vendors and Software Companies

Keystone Precision Instruments
1670 East Race Street
Allentown, PA 18109
www.keypre.com

Trimble RealWorks Survey
Trimble PointScape

Kubit USA
P.O. Box 7680
Houston, TX 77270
www.kubitUSA.com

Kubit PointCloud

R. Larry Holtgreive
3D Consultants, LLC
3dc.llc@comcast.net

Index

Symbols

1964, Venice Charter of 42

A

Accuracy 78

Analog 1

assessment, condition 65

assessment, Risk 3

B

C

CAD 27, 82

calibrator, atmospheric correction 69

cloud, point 27

Cloud, Point 80

colonization, microbiological 10

Crumbling 10

Crusts 9

Cycle, Conservation 1

D

data, Base-line 1

Decay, Rate of 3

Deformation 11

density, air 69

density, Point 3

Detachment 11

Deterioration, Stone 7

Discoloration 9

disintegration, Granular 10

divergence, Beam 1

Drawing, Hand 80

E

efflorescence 9

erosion, Differential 9

Error 2

error, Random 3

error, residual registration 69

error, Systematic 4

Exchange, Merchants' 8, 65
expansion, Linear coefficient of thermal 69

F

Fissures 11
Fitzner 8
Flaking 10

G

Geo-referencing 2

H

Heritage, Cultural 1

I

Information, 3D 82
information, Heritage 2

J

K

L

Laboratory, Architectural Conservation 8, 65
level, Dumpy 1
Lion, North 73
Lion, South 73

M

Marble, Pennsylvania Blue 65
Maya 81
Meter, Microerosion 24
meters, microerosion 15
Microkarst 9
Modeling 79
Modeling, Geometric 2
Monitoring 2, 42, 53, 84
moulds 15
Moulds 38

N

O

out, Break 9

P

Philadelphia 65
photogrammetry 15, 31
Photogrammetry 19
Photos, Draping 75
pins, erosion 15
Pins, Erosion 37
Printing 82
Problem, Mixed Edge 2
profilometry 15
Profilometry 16

Q

Quantifying 42

R

Rate, Recession 3
Rates, Recession 86
RealWorks, Trimble 88
Reconnaissance 3
Recording 3, 42
registration, cloud-to-cloud 88
registration, target-based 70
Relief 8
Resolution 3, 77
Resolution, Sampling 54
roughness 12

S

scaling, Contour 10
Scanners, 3D Laser 27
scanners, Airborne laser 32
scanners, Phase-comparison 32
scanners, Triangulation 31
scanner, Trimble GX laser 66
scanning, 3D laser 15, 65
Size, Spot 3
Soiling 9
splintering 10
station, Scanning 3
sugaring 10
Survey, Condition 65
Survey, Metric 2

surveys, graphic condition 15
Surveys, Graphic Condition 40

T

target 70
temperatures 69
Texturizing 4
Theodolite 4
thermo-compensator, real time 69

U

V

W

weathering, Back 8
Workflow 71

X

Y

Z