

## COPYRIGHT NOTICE



**FedUni ResearchOnline**  
<http://researchonline.federation.edu.au>

This is the peer-reviewed version of the following article:

**Khorshidi, H., Gunawan, I., Ibrahim, Y.** (2014) Financial view and profitability evaluation on multistate weighted k-out-of-n:F system reliability. *International Journal of Reliability and Safety*, 8(2-4), 284-298.

The final and definitive version of this article can be found at:  
<http://doi.org/10.1504/IJRS.2014.069523>

Copyright © 2014 Inderscience Enterprises Ltd.

---

## **Financial view and profitability evaluation on multi-state weighted $k$ -out-of- $n:F$ system reliability**

---

Hadi Akbarzade Khorshidi\*

School of Applied Sciences and Engineering,  
Faculty of Science,  
Monash University,  
Melbourne, VIC, Australia  
Email: hadi.khorshidi@monash.edu  
\*Corresponding author

Indra Gunawan and M. Yousef Ibrahim

School of Engineering and Information Technology,  
Federation University Australia,  
Gippsland Campus,  
Churchill, VIC 3842, Australia  
Email: indra.gunawan@federation.edu.au  
Email: yousef.ibrahim@federation.edu.au

**Abstract:** A financial view is proposed for reliability evaluation of multi-state weighted  $k$ -out-of- $n:F$  systems. Failure cost as the cost which is imposed on the components by failures is used to denote the importance weight of each component. The deterioration process of components over time is modelled by Markov chain. System failure behaviour is formulated by Universal Generating Function (UGF). Furthermore, the present value of system failure is calculated by considering time value of money. As a result, the system reliability is demonstrated as cost which is more sensible for managers. A numerical example is presented to illustrate the proposed approach. After that, a way is suggested to transform the system cost present value into system reliability value. MATLAB programming is developed to make a sensitivity analysis on example results. Therefore, the impact of maintenance activities is investigated to show how they can reduce system cost through improving the system reliability.

**Keywords:** multi-state weighted  $k$ -out-of- $n:F$  system; reliability assessment; failure cost; UGF; universal generating function; present value; financial concepts; profitability.

**Reference** to this paper should be made as follows: Khorshidi, H.A., Gunawan, I. and Ibrahim, M.Y. (XXXX) 'Financial view and profitability evaluation on multi-state weighted  $k$ -out-of- $n:F$  system reliability', *Int. J. Reliability and Safety*, Vol. X, No. Y, pp.xxx-xxx.

**Biographical notes:** Hadi Akbarzade Khorshidi is a PhD student in the School of Applied Sciences and Engineering at Monash University, Australia. He received his Master's degree in Industrial Engineering from Isfahan University of Technology, Isfahan, Iran, in 2010, and his BSc in Railway Engineering from Iran University of Science and Technology, Tehran, Iran, in 2008. His

*H.A. Khorshidi, I. Gunawan and M.Y. Ibrahim*

research interests are in reliability, quality management, system dynamics and optimisation. He has published some papers in international conferences and journals.

Indra Gunawan is a Senior Lecturer and Coordinator of Postgraduate Programs in Maintenance and Reliability Engineering in the School of Engineering and Information Technology at Federation University, Gippsland Campus, Australia. He completed his PhD in Industrial Engineering from Northeastern University, USA. His main areas of research are maintenance and reliability engineering, project management, application of operations research, operations management, applied statistics, probability modelling and engineering systems design. His work has appeared in many peer-reviewed journals and conference proceedings.

M. Yousef Ibrahim received his PhD in 1993 from University of Wollongong. He joined Monash University where he established the Graduate Certificate in Reliability Engineering by distance education. In 1997, he established the Master degree in Maintenance and Reliability Engineering by distance education. He is currently a Professor of Engineering with Federation University Australia, Gippsland Campus. He has been the general chair of several international conferences. He has research interests in life cycle costs, reliability engineering, mechatronics and industrial automation.

---

## **1 Introduction**

The main goal of reliability engineering is to generate reliable systems (Tavakkoli-Moghaddam et al., 2008). System reliability evaluation (prediction) is a preliminary step to reach the reliable systems (Saleh and Marais, 2006). System evaluation usually precedes system improvement. System structure, system state and reliability index of the components are used for system reliability estimation. System reliability optimisation models provide an opportunity to consider system cost in creating reliable systems (Khorshidi et al., 2013). As a result, combination of costs in evaluation of the system reliability is of high importance.

The main problem that maintenance and reliability engineers are facing in industries is communication with top management to fulfil the required budget. They should not only express the maintenance issues in financial and economic way, but also show their positive impact on revenue generation. Accountants consider maintenance as cost, top management wants to have suggestions in economic terms and engineers use technical language to formulate the problems (Ahlmann, 1984). Money is an index that managers can simply understand (Rhee and Ishii, 2003). Consequently, finding a common language between managers and engineers in terms of maintenance activities and reliability improvement is important (Alsyouf, 2007). This paper tries to translate availability concept into financial issues that either make it understandable for managers or help the managers to decide on maintenance and improvement opportunities. An available component (or machine) can generate income for the system (Saleh and Marais, 2006). Similarly, production stoppage due to failures increases cost and reduces profitability (Alsyouf, 2007). This research uses this fact for system reliability evaluation. As a result,

### *Financial view and profitability evaluation*

it can provide the relationship between reliability (engineers' view) and cost–benefit (top managers' demand). It also shows how investment on maintenance and reliability improvement activities can reduce system cost.

The cost imposed by a failure through production stoppage and missing availability is defined as failure cost. In fact, failure deprives the system of income that can be generated when the system is working reliably, which is called reliability value. Since it is homogeneous with cost, it can provide decision-makers a simple way to compare improvement strategies' advantages with their associated costs. Also, it helps to develop optimisation models for making optimal decisions on system design and improvement actions in regard of reliability and cost simultaneously. Tam et al. (2007) consider income generated during operation periods to develop an optimisation model for a series of systems to decide on maintenance actions in the present of replacement cost, maintenance cost, maintenance downtime cost and failure cost. In addition, there is an opportunity to consider time value of money to which reliability is transformed. Therefore, present value of reliability can be calculated via engineering economics' tools. Present value is a financial measure in which future estimated values are converted to the present time, which usually takes fewer amounts due to interest rate (Blank and Tarquin, 2012); therefore, present value of reliability is the present value of the expected generated income by the available system over time. Marais and Saleh (2009) use reliability value to assess multi-state system reliability and cost. Hamadani and Khorshidi (2013) employ the income generated by the components to evaluate the series-parallel systems and develop a multi-objective optimisation model. In Marais (2013), maintenance value is used to estimate the net present value of system by semi-Markov decision process and dynamic programming. Also, translating system reliability into failure cost provides an occasion to develop bi-objective optimisation model through a single-objective function. A cost minimisation model can either maximise system reliability or minimise system cost instantaneously. In addition, the proposed evaluation method is helpful for decision-makers to make decisions for each time period separately (more illustration is provided in Section 4.1).

The  $k$ -out-of- $n$  systems are popular system structures with a wide application in real systems. The multi-engine aircraft, the multi-display system cockpit, the multi-transmitter system in communication system and the oil supply system with multiple pipelines are some illustrations about  $k$ -out-of- $n$  systems (Kuo and Zou, 2003; Tian et al., 2009b). A  $k$ -out-of- $n:F(G)$  system fails (works) if and only if at least  $k$  components fail (work). A 1-out-of- $n:F$  system is a series system, and an  $n$ -out-of- $n:F$  system is a parallel system (Yamamoto et al., 2011). Also, a weight which shows the importance of each component can be allocated. Therefore,  $k$  would be the summation of allocated weights for the mentioned components (Li and Zuo, 2008). Generally, a weighted  $k$ -out-of- $n$  system can cover the whole features of the  $k$ -out-of- $n$  systems (Wu and Chen, 1994a). A system with a finite number of performance levels is called a multi-state system. In multi-state systems, there are some middle states between perfect functioning and complete failure as deteriorated states. These types of systems are more flexible to represent real industrial systems (Lisnianski et al., 2010). Therefore, components can have different weights to denote diverse states. Multi-state weighted  $k$ -out-of- $n$  systems have been evaluated widely in recent years by researchers (Eryilmaz and Rıza Bozbulut, 2014; Khorshidi et al., 2014; Tian et al., 2008). Consequently, a multi-state weighted  $k$ -out-of- $n:F$  system is in state  $j$  or below if the total weight of all components is equal to or greater than a threshold value  $k_j$ .

The reliability of consecutive weighted  $k$ -out-of- $n:F$  systems has been computed with minimal cut sets recursively in Wu and Chen (1994b). Eryilmaz and Yazgi Tutuncu (2009) propose a recursive formula to evaluate the reliability of consecutive weighted  $k$ -out-of- $n:F$  systems with binary components. Yamamoto et al. (2011) used a recursive algorithm to estimate multi-state  $k$ -out-of- $n:F$  systems. In Ding et al. (2012), a definition for multi-state weighted  $k$ -out-of- $n:F$  systems is introduced, and the system is evaluated by the Universal Generating Function (UGF) method. However, they define the weight in the same way as that of the  $k$ -out-of- $n:G$  systems. Eryilmaz (2014) studies parallel and consecutive- $k$ -out-of- $n:F$  systems with components which their reliability level deteriorates randomly over time. As can be seen, the reliability evaluation of  $k$ -out-of- $n:F$  systems has been considered independently from  $k$ -out-of- $n:G$  systems.

In general, this paper proposes a model for computing multi-state weighted  $k$ -out-of- $n:F$  system reliability based on failure cost by the UGF approach. Failure cost is considered as weight. Since different components can generate different levels of income in their different states (Hamadani and Khorshidi, 2013), there are different levels of failure cost for the system (multi-state weighted  $k$ -out-of- $n:F$  system). The components' state distribution is calculated via the Markov chain.

The rest of the paper is organised as follows. In Section 2, the UGF approach is introduced briefly. Also, it is attempted to employ new formulations to present UGF in a more understandable way than previous works such as Levitin (2005) and Lisnianski et al. (2010). Section 3 focuses on the proposed model for a multi-state weighted  $k$ -out-of- $n:F$  system reliability evaluation. A numerical example is provided in Section 4. Section 5 presents the concluding remarks.

## 2 Universal Generating Function (UGF)

The basic concepts of the UGF approach have been introduced by Ushakov (1986). UGF is a special form of moment generating function to represent the probability distribution of variables in polynomial expressions. This property facilitates calculating the probability distribution for a set of variables. Suppose  $n$ -independent variables like  $X_1, \dots, X_n$ . The probability distribution of each variable is discretely represented by  $x_{ij}$  and  $p'_{ij}$ , which are the value of variable  $i$  in possible state  $j$  and its corresponding probability, respectively. Each variable has  $k_i$  different number of states. UGF shows the probability distribution of variables by  $u$ -function ( $u_{X_i}(z)$ ) as equation (1) in a polynomial structure:

$$u_{X_i}(z) = \sum_{j=1}^{k_i} p'_{ij} z^{x_{ij}} \quad (1)$$

The polynomial properties are helpful to find the  $u$ -function for a function of variables  $f(X_1, \dots, X_n)$ . All possible combinations of the variable states should be considered to generate the final  $u$ -function. The total number of possible combinations is calculated by equation (2):

$$K = \prod_{i=1}^n k_i \quad (2)$$

### Financial view and profitability evaluation

Each combination ( $j'$ ) includes two sets, values and probabilities, based on the associated variables. The size of each set is equal to the number of variables. Therefore, there are two matrices to denote all combinations, which are shown in equation (3):

$$Y = [x_{ij}]_{K \times n}, Q = [p'_{ij}]_{K \times n} \quad (3)$$

where  $Y$  and  $Q$  are the combinations of variable values and probabilities, respectively. For instance, consider two variables like  $X_1$  and  $X_2$  with probability distributions  $x_1 = \{2, 3\}$ ,  $p'_1 = [0.4, 0.6]$  and  $x_2 = \{1, 4, 5\}$ ,  $p'_2 = [0.2, 0.5, 0.3]$ . The  $u$ -function for these two variables can be obtained as follows:

$$u_{x_1}(z) = 0.4z^2 + 0.6z^3$$

$$u_{x_2}(z) = 0.2z^1 + 0.5z^4 + 0.3z^5$$

The number of all possible combinations is calculated as  $K = k_1 \times k_2 = 2 \times 3 = 6$ . As a result, the dimension of value and probability matrices is  $6 \times 2$ , and the matrices are constructed as follows:

$$Y = \begin{bmatrix} 2 & 1 \\ 2 & 4 \\ 2 & 5 \\ 3 & 1 \\ 3 & 4 \\ 3 & 5 \end{bmatrix}, Q = \begin{bmatrix} 0.4 & 0.2 \\ 0.4 & 0.5 \\ 0.4 & 0.3 \\ 0.6 & 0.2 \\ 0.6 & 0.5 \\ 0.6 & 0.3 \end{bmatrix}$$

Based on these matrices, the corresponding value of the function ( $f_{j'}$ ) and its probability ( $q_{j'}$ ) can be obtained by equations (4) and (5), respectively. The probability of each combination is the product of the probabilities, and the combination's value is calculated via the function

$$f_{j'} = f(Y_{j'1}, \dots, Y_{j'n}) \quad (4)$$

$$q_{j'} = \prod_{i=1}^n Q_{j'i} \quad (5)$$

where  $j'$  can be equal to 1, 2, ..., or  $K$ . After that, the combination measures (probability and value) are combined together in polynomial expression by an operator  $\otimes_f$  using equation (6):

$$\otimes_f \left( \sum_{j=1}^{k_i} p'_{ij} z^{x_{ij}} \right) = \sum_{j'=1}^K q_{j'} z^{f_{j'}} \quad (6)$$

As a result, the  $u$ -function of the set of variables can be obtained based on the variables'  $u$ -functions as equation (7):

$$U(z) = \otimes_f (u_{x_1}(z), u_{x_2}(z), \dots, u_{x_n}(z)) \quad (7)$$

For the examples, the measures of the first combinations are  $f_1 = f(Y_{11}, Y_{12}) = f(2, 1)$  and  $q_1 = Q_{11} \times Q_{12} = 0.4 \times 0.2 = 0.08$ . This continues to compute the measures of all possible combinations. The  $u$ -function of the set ( $U(z)$ ) is as follows:

$$U(z) = 0.08z^{f^{(2,1)}} + 0.2z^{f^{(2,4)}} + 0.12z^{f^{(2,5)}} + 0.12z^{f^{(3,1)}} + 0.3z^{f^{(3,4)}} + 0.18z^{f^{(3,5)}}$$

### 3 System reliability evaluation

In this paper, the functioning periods of  $k$ -out-of- $n:F$  system in addition to design time have been studied. It can provide decision-making for the system during functioning periods. Also, the income which is missed by each component through time periods is employed to show the weight of the failure. Therefore, this index can provide, using engineering economics, techniques to calculate the present value of system reliability. The components are multi-state, which have different income generating rates in different states. Firstly, to evaluate this system, the probability of being the components in each state in different time periods should be determined. The considered assumptions are as below:

- The time to failure of each component is independent.
- Each component starts working in perfect functioning state.
- Since the components in  $k$ -out-of- $n:F$  systems work in parallel, the failure cost of the system is equal to the summation of components' cost.

#### 3.1 Determining the probability

Each component through time periods can transmit from each state to another state or can remain in the same state with an identified probability. The transition probability of component  $i$  from state  $k$  to state  $j$  is denoted by  $p_{kj}^i$ . Each component may change its state to lower or higher state by failures or routine maintenance activities. Transition probabilities are shown in a Transition Matrix (TM) as equation (8):

$$TM = \begin{bmatrix} P_{00}^i & \cdots & P_{0M}^i \\ \vdots & \ddots & \vdots \\ P_{M0}^i & \cdots & P_{MM}^i \end{bmatrix} \text{ and } \forall_i, \sum_{j=0}^M P_{kj}^i = 1 \quad (8)$$

Figure 1 is provided to illustrate the components' states and the state transitions during the time periods. In this diagram, each component has three different states: 0, 1 and 2, where 0 is complete failure and 2 is perfect functioning. As assumed, the component at the starting point is in state 2. The component works in four periods, and can remain in its previous state or change to other states during each period based on transition probabilities. Finding component probabilities is important in the UGF approach to evaluate the system reliability. The probability of being component  $i$  in state  $j$  at time  $t$  ( $P_{kj}^i(t)$ ) is computed by the transition probabilities as equation (9):

$$P_j^i(t) = \sum_{k=0}^M p_k^i(t-1) p_{kj}^i, \quad i = 1, \dots, n; t = 1, \dots, T \quad (9)$$

where at design time ( $t = 0$ ):  $P_M^i(0) = 1, P_0^i(0) = \cdots = P_{M-1}^i(0) = 0$ .

### Financial view and profitability evaluation

The system is structured as weighted  $k$ -out-of- $n:F$  system. The UGF computes the probability of being the whole system in state  $j$  at time  $t$ . After that, the present value of the whole system could be calculated based on the system probability distribution, their equivalent failure cost and interest rate.

**Figure 1** Different states of a component during the operational periods

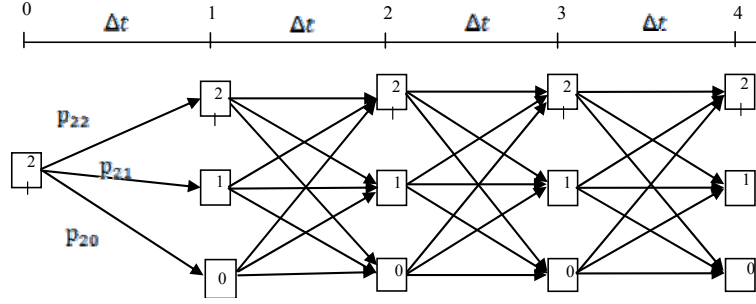

### 3.2 System evaluation by UGF

As mentioned earlier in Section 2, the  $u$ -function of each component at each time period should be created based on the components' probability (equation 10). The computed probabilities (by equation 2) have been employed to construct the  $u$ -function of component  $i$  in state  $j$  at time  $t$  ( $u_t^i(z)$ ):

$$u_t^i(z) = P_0^i(t)z^{Fc_0^i} + \dots + P_M^i(t)z^{Fc_M^i} = \sum_{j=0}^M P_j^i(t)z^{Fc_j^i} \quad (10)$$

where  $Fc_j^i$  is the failure cost of component  $i$  in state  $j$ .

According to the definition of multi-state weighted  $k$ -out-of- $n$  systems mentioned in Section 1, the failure cost of the whole system at each time period is obtained by the summation of the components' failure cost. The  $u$ -function for the whole system at time  $t$  ( $U_t(z)$ ) can be calculated based on the  $u$ -function of the components by using formulae (2)–(7), introduced in Section 2. Equation (11) computes the system's probability distribution using the UGF approach. Since failure cost would be added together, operator  $\otimes_+$  is used instead of operator  $\otimes_f$  in equation (7):

$$u_t(z) = \otimes_+ (u_t^1(z), u_t^2(z), \dots, u_t^n(z)) = \sum Pz^{Fc} \quad (11)$$

where  $Fc$  is the failure cost of the system.

Different levels of cost can be obtained for the system by using the UGF approach where each level has an equivalent probability value. Since some threshold values have been specified for weighted  $k$ -out-of- $n$  systems to indicate various reliability states, equation (12) calculates the probability that the system is in each state by adding the equivalent probabilities of the cost levels which lie between the thresholds.  $R_t^s(k_j, n)$  is the probability for the system to be in state  $j$  (has failure cost  $k_j$ ) at time  $t$ :

$$R_t^s(k_j, n) = \sum P, \text{ for } k_j \leq Fc < k_{j+1} \quad (12)$$



As a result, the equivalent probabilities of each classification are added together to find the probability of each state at each time period.

### 3.3 System present value

Suppose the equivalent failure cost for the system in each state ( $j$ ) is  $K_j$ . Then, the present value for the system's failure cost would be calculated according to equation (13):

$$PV_F = \sum_{j=0}^M \sum_{t=0}^T R_t^s(k_j, n) \cdot k_j / (1+r)^t \quad (13)$$

where  $r$  is interest rate.

Since the system reliability is evaluated with cost, it can provide an opportunity to consider other system costs. As a result, system reliability and system cost can be compared together simply. Different strategies can be analysed to find the most appropriate one by considering reliability and cost simultaneously. Also, this view facilitates developing new optimisation models.

## 4 Numerical example

To illustrate the proposed reliability evaluation of multi-state weighted  $k$ -out-of- $n:F$  system, a numerical example is introduced. Consider a manufacturing system in which three different machines work together with various production rates. Each machine has three possible states. Also, there are four functioning time periods (Figure 1). The machines can generate different levels of income based on their reliability states as in Table 1.

**Table 1** Income generating distribution of machines

state	0	1	2
machine			
1	0	2	3
2	0	3	4
3	0	3	5

Accordingly, each machine can have equivalent costs caused by failures in different states that are presented in Table 2. In fact, these costs are the missed income in comparison with the perfect functioning state in deteriorated states and complete failure state.

**Table 2** Failure cost distribution of machines

State	0	1	2
Machine			
1	3	1	0
2	4	1	0
3	5	2	0

*Financial view and profitability evaluation*

For the whole system, the system is in state 0 if the total failure cost is more than 10 ( $k_0 = 10$ ); the failure cost in  $[4,10)$  interval places the system in state 1 ( $k_1 = 4$ ); if the total failure cost is between 0 and 4, then the system is in state 2 ( $k_2 = 0$ ). Table 3 shows the transition probabilities for machine 1 in different states.

**Table 3** TM for machine 1

State \ State	0	1	2
0	0.5	0.35	0.15
1	0.2	0.7	0.1
2	0.05	0.15	0.8

Table 4 shows the transition probabilities for machine 2 in different states.

**Table 4** TM for machine 2

State \ State	0	1	2
0	0.45	0.3	0.25
1	0.15	0.65	0.2
2	0.03	0.07	0.9

Table 5 shows the transition probabilities for component 3 in different states.

**Table 5** TM for machine 3

State \ State	0	1	2
0	0.5	0.4	0.1
1	0.25	0.7	0.05
2	0.05	0.25	0.7

Besides, the interest rate is considered as 0.1 ( $r = 0.1$ ). First of all, the probability of being each machine in different states through different periods should be computed using transition matrices. These probabilities have been calculated for machine 1 at time period 1 as follows:

$$\begin{cases} P_2^1(1) = 0 \times 0.15 + 0 \times 0.1 + 1 \times 0.8 = 0.8 \\ P_1^1(1) = 0 \times 0.35 + 0 \times 0.7 + 1 \times 0.15 = 0.15, \quad \sum_{j=0}^2 P_j^1(1) = 1 \\ P_0^1(1) = 0 \times 0.5 + 0 \times 0.2 + 1 \times 0.05 = 0.05 \end{cases}$$

In this way could all probabilities be calculated. Table 6 shows the calculated probability of being in each state in different periods for machine 1.

**Table 6** Probability distribution of machine 1

State \ period	0	1	2	3
0	0	0.05	0.095	0.129
1	0	0.15	0.243	0.302
2	1	0.8	0.662	0.569

Table 7 shows the calculated probability of being in each state in different periods for machine 2.

**Table 7** Probability distribution of machine 2

<i>State</i> \ <i>period</i>	0	1	2	3
0	0	0.03	0.051	0.066
1	0	0.07	0.117	0.15
2	1	0.9	0.832	0.784

Table 8 shows the calculated probability of being in each state in different periods for machine 3.

**Table 8** Probability distribution of machine 3

<i>State</i> \ <i>period</i>	0	1	2	3
0	0	0.05	0.123	0.179
1	0	0.25	0.37	0.435
2	1	0.7	0.507	0.386

Subsequently, the UGF approach is employed to estimate system reliability. The  $u$ -functions for machines are obtained by equation (10). Based on the components'  $u$ -functions, the  $u$ -function of the system and system probability at different times can be calculated by equations (11) and (12). Table 9 shows the calculated probability distribution of the whole system by UGF for different states and time periods.

**Table 9** The probability distribution of the system using UGF

<i>State</i> \ <i>Period</i>	0	1	2	3
0	0	0.001	0.002	0.005
1	0	0.095	0.215	0.308
2	1	0.904	0.783	0.687

Therefore, the probability for the system at time 1 to be in state 2 is 0.904, in state 1 is 0.095 and in state 0 is 0.001. As expected, the probability of being in state 2 is decreasing, and the probability of being in state 0 is increasing over time. Using these probabilities, the expected value of the system failure in each period can be computed. The cash flow of the value is shown in Figure 2.

Based on the cash flow, the present value of the failure cost for the system is calculated using interest rate as below:

$$PV_F = \sum_{j=0}^2 \sum_{t=0}^3 R_t^s(k_j,3)k_j / (1+0.1)^t = 2.04$$

This value can help managers decide about improving strategies. If the strategies reduce the system's present value more than their cost, they can be considered for implementation. Also, this value provides a measure for ranking the strategies.

*Financial view and profitability evaluation*

**Figure 2** The failure cost cash flow

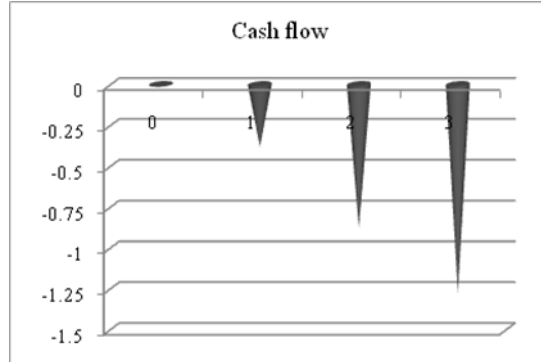

Since this value is generated by failure cost, it denotes the present value of the failure. As a result, it should be transformed to a positive value to represent the present value of system reliability. There is a relationship between the failure probability (unreliability) and reliability (Xie et al., 2004) as shown equation (14); therefore, the transformation can be used similarly:

$$R(t) = 1 - F(t) \tag{14}$$

To reach this goal, the present value of the system with no failure (perfect income) is considered. In other words, all machines are in state 2 for all time periods. Therefore, for this case, the system can have ten incomes generated for all periods. The present value of the mentioned system is computed as below:

$$PV_{Perfect} = \sum_{t=0}^3 \frac{10}{(1+0.1)^t} = 34.87$$

Figure 3 shows the cash flow of two situations together.

**Figure 3** Final cash flow

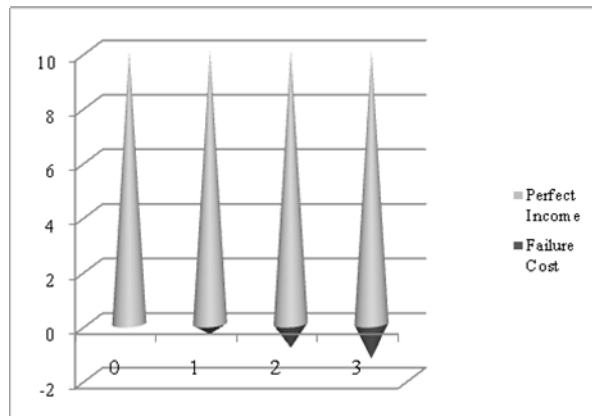

As a result, the difference between these two amounts is the present value of the system reliability (equation 15):

$$PV_R = PV_{Perfect} - PV_F \quad (15)$$

Consequently, the present value of system reliability for the weighted  $k$ -out-of- $n:F$  system is computed by equation (15). The  $PV_R$  comes from the difference between the perfect situation and failure cost:

$$PV_R = 34.87 - 2.04 = 32.83$$

#### 4.1 Discussion

The proposed evaluation method for the manufacturing system has been programmed by MATLAB. The program helps evaluate the system either in more operational time periods or having improvement strategies. Figure 4 shows the system cash flow for 20 time periods. The present value of system failure cost is 14.

**Figure 4** System cash flow

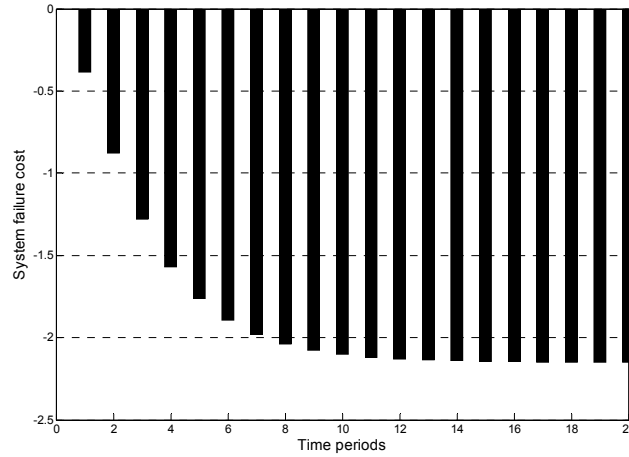

As can be seen, the associated cost of failure is increasing during time periods. However, the slope of cost increase (failure) in initial time periods is more than the final ones. In addition, the impact of maintenance strategies can be investigated. These strategies can be considered preventive maintenance plans. Maintenance plans either prevent components from failing to lower states or promote them to higher states (Tian et al., 2009a). Therefore, they are effective on transition probabilities, and subsequently on system reliability. In addition, these plans can be applied at any time period (at the beginning or operational periods). Equations (16) and (17) show how a maintenance plan affects transition probabilities:

$$\bar{p}_{kj}^i = p_{kj}^i \cdot a_{kj}^i \cdot m \quad (16)$$

$$\bar{p}_{kj}^i = \bar{p}_{kj}^i / \sum_{j=0}^M \bar{p}_{kj}^i \quad (17)$$

*Financial view and profitability evaluation*

where  $\bar{p}_{kj}^i$  is the normalised updated transition probability,  $m$  is a Boolean variable that is 1 when maintenance plan is applied,  $a_{kj}^i$  is a factor that denotes the effect of maintenance plan on transition probabilities and  $\bar{p}_{kj}^i$  is the updated probability transition based on the maintenance plan and its factor. Suppose the maintenance plan is increasing resource and manpower. Therefore, it can promote transitions to higher states and reduce failure to lower states as following factors:  $a_{0,1}^i = a_{1,2}^i = a_{0,2}^i = 1.5$ ,  $a_{1,0}^i = a_{2,1}^i = a_{2,0}^i = 0.9$  and  $a_{0,0}^i = a_{1,1}^i = a_{2,2}^i = 1$ . Figure 5 compares this new situation with no maintenance plan situation. The black line shows the trend if maintenance plan is applied from the beginning of the system. The cost related to the failure stands in a better level, and the present value of system failure cost is 10.7.

**Figure 5** System failure cost trend

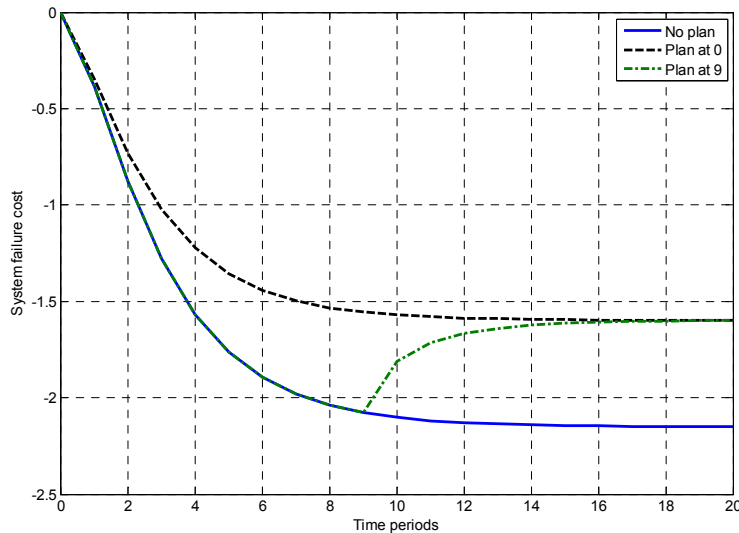

One can decide that the maintenance plan be applied during operational periods. The green line is a trend if the plan is applied at the ninth time period; the equivalent present value for this condition is 12.7. Also, Table 10 shows the present value of system failure cost when maintenance plan is applied at different time periods.

**Table 10** Comparison results for present value of system failure cost with maintenance plan

Time period	0	2	4	6	8	10	12	14	16	18	20
Present value	10.7	11	11.5	12	12.5	12.9	13.2	13.5	13.7	13.9	14

As you can see, the later the maintenance plan application, the lower the impact on failure cost reduction. This information helps decision-makers to make optimum decisions on type and time of improvement strategies based on their cost and reduction on system failure cost.

## 5 Conclusion

In this paper, the reliability of multi-state weighted  $k$ -out-of- $n:F$  systems has been evaluated using the components' failure cost. The income misses in deteriorated states and failures are considered as failure cost. The failure cost is employed as component weights. It facilitates either evaluating  $k$ -out-of- $n:F$  systems or using financial techniques. Also, using failure cost as reliability index can provide an opportunity to investigate other system costs such as installation cost, maintenance and replacement into system reliability evaluation. In addition, the improvement strategies can be analysed by the proposed method. If the strategy reduces the system failure cost in comparison to the cost carried out for purchasing equipment and employing maintenance personnel, it could be considered an economic and feasible strategy by system stakeholders. Also, this measure can rank different strategies to find the most efficient one.

The UGF approach is introduced with new formulations. The system reliability is estimated by the UGF approach. Then, the system's present value is calculated based on system failure cost and system probabilities. Furthermore, the present value of system failure is transformed to the present value of system reliability. As a result, two measures,  $PV_F$  and  $PV_R$ , have been provided for weighted  $k$ -out-of- $n:F$  system evaluation, which can estimate system failure and reliability values, respectively. Finally, it is shown how maintenance improvements can generate profit for the company by reducing system failure costs.

## References

- Ahlmann, H. (1984) 'Maintenance effectiveness and economic models in the terotechnology concept', *Maintenance Management International*, Vol. 4, No. 2, pp.131–139.
- Alsyouf, I. (2007) 'The role of maintenance in improving companies' productivity and profitability', *International Journal of Production Economics*, Vol. 105, No. 1, pp.70–78.
- Blank, L. and Tarquin, A. (2012) *Engineering Economy*, 7th ed., McGraw-Hill, New York.
- Ding, Y., Zio, E., Li, Y., Cheng, L. and Wu, Q. (2012) 'Definition of multi-state weighted  $k$ -out-of- $n:F$  systems', *International Journal of Performability Engineering*, Vol. 8, No. 2, pp.217–219.
- Eryilmaz, S. (2014) 'Parallel and consecutive- $k$ -out-of- $n:F$  systems under stochastic deterioration', *Applied Mathematics and Computation*, Vol. 227, pp.19–26.
- Eryilmaz, S. and Rıza Bozbulut, A. (2014) 'An algorithmic approach for the dynamic reliability analysis of non-repairable multi-state weighted  $k$ -out-of- $n:G$  system', *Reliability Engineering & System Safety*, Vol. 131, pp.61–65.
- Eryilmaz, S. and Yazgi Tutuncu, G. (2009) 'Reliability evaluation of linear consecutive-weighted- $k$ -out-of- $n:F$  system', *Asia-Pacific Journal of Operational Research*, Vol. 26, No. 6, pp.805–816.
- Hamadani, A.Z. and Khorshidi, H.A. (2013) 'System reliability optimization using time value of money', *International Journal of Advanced Manufacturing Technology*, Vol. 66, Nos. 1–4, pp.97–106.
- Khorshidi, H.A., Gunawan, I. and Ibrahim, M.Y. (2013) 'Investigation on system reliability optimization based on classification of criteria', *Proceedings of the IEEE International Conference on Industrial Technology*, 25–28 February, Cape Town, pp.1706–1711.
- Khorshidi, H.A., Gunawan, I. and Ibrahim, M.Y. (2014) 'On reliability evaluation of multistate weighted  $k$ -out-of- $n$  system using present value', *Engineering Economist*, Vol. 60, No. 1, pp.22–39.

### *Financial view and profitability evaluation*

- Kuo, W. and Zou, M.J. (2003) *Optimal Reliability Modeling: Principles and Applications*, John Wiley & Sons, New York.
- Levitin, G. (2005) *The Universal Generating Function in Reliability Analysis and Optimization*, Springer-Verlag, London.
- Li, W. and Zuo, M.J. (2008) 'Reliability evaluation of multi-state weighted  $k$ -out-of- $n$  systems', *Reliability Engineering and System Safety*, Vol. 93, No. 1, pp.161–168.
- Lisnianski, A., Frenkel, I. and Ding, Y. (2010) *Multi-State System Reliability Analysis and Optimization for Engineers and Industrial Managers*, Springer-Verlag, London.
- Marais, K.B. (2013) 'Value maximizing maintenance policies under general repair', *Reliability Engineering and System Safety*, Vol. 119, pp.76–87.
- Marais, K.B. and Saleh, J.H. (2009) 'Beyond its cost, the value of maintenance: an analytical framework for capturing its net present value', *Reliability Engineering and System Safety*, Vol. 94, No. 2, pp.644–657.
- Rhee, S.J. and Ishii, K. (2003) 'Using cost based FMEA to enhance reliability and serviceability', *Advanced Engineering Informatics*, Vol. 17, Nos. 3–4, pp.179–188.
- Saleh, J.H. and Marais, K. (2006) 'Reliability: how much is it worth? Beyond its estimation or prediction, the (net) present value of reliability', *Reliability Engineering and System Safety*, Vol. 91, No. 6, pp.665–673.
- Tam, A.S.B., Chan, W.M. and Price, J.W.H. (2007) 'Maintenance scheduling to support the operation of manufacturing and production assets', *International Journal of Advanced Manufacturing Technology*, Vol. 34, Nos. 3–4, pp.399–405.
- Tavakkoli-Moghaddam, R., Safari, J. and Sassani, F. (2008) 'Reliability optimization of series-parallel systems with a choice of redundancy strategies using a genetic algorithm', *Reliability Engineering and System Safety*, Vol. 93, No. 4, pp.550–556.
- Tian, Z., Li, W. and Zuo, M.J. (2008) 'Modeling and reliability evaluation of multi-state  $k$ -out-of- $n$  systems', in Pham, H. (Ed.): *Recent Advances in Reliability and Quality in Design*, Springer London, pp.31–56.
- Tian, Z., Levitin, G. and Zuo, M.J. (2009a) 'A joint reliability-redundancy optimization approach for multi-state series-parallel systems', *Reliability Engineering and System Safety*, Vol. 94, No. 10, pp.1568–1576.
- Tian, Z., Zuo, M. and Yam, R. (2009b) 'Multi-state  $k$ -out-of- $n$  system and their performance evaluation', *IIE Transactions*, Vol. 41, No. 1, pp.32–44.
- Ushakov, I.A. (1986) 'Universal generating function', *Soviet Journal of Computer and Systems Sciences*, Vol. 24, No. 5, pp.118–129.
- Wu, J-S. and Chen, R-J. (1994a) 'An algorithm for computing the reliability of weighted- $k$ -out-of- $n$  systems', *IEEE Transactions on Reliability*, Vol. 43, No. 2, pp.327–328.
- Wu, J-S. and Chen, R-J. (1994b) 'Efficient algorithms for  $k$ -out-of- $n$  & consecutive-weighted- $k$ -out-of- $n$ : $F$  system', *IEEE Transactions on Reliability*, Vol. 43, No. 4, pp.650–655.
- Xie, M., Dai, Y.S. and Poh, K.L. (2004) 'Basic reliability concepts and analysis', in *Computing System Reliability: Models and Analysis*, Kluwer Academic/Plenum Publishers, New York, pp.7–40.
- Yamamoto, H., Akiba, T., Yamaguchi, T. and Nagatsuka, H. (2011) 'An evaluating algorithm for system state distributions of generalized multi-state  $k$ -out-of- $n$ : $F$  systems', *Journal of Japan Industrial Management Association*, Vol. 61, No. 6, pp.347–354.