

April 2017

Designing a Biomimetic Prosthetic Flipper for a Kemp's Ridley Sea Turtle

Andrew Parker Dunne
Worcester Polytechnic Institute

Aryelle Jaclayne Teixeira
Worcester Polytechnic Institute

Christopher James Ryan
Worcester Polytechnic Institute

Frederick Harmon Burgwardt
Worcester Polytechnic Institute

Paul Anthony DePlacido
Worcester Polytechnic Institute

See next page for additional authors

Follow this and additional works at: <https://digitalcommons.wpi.edu/mqp-all>

Repository Citation

Dunne, A. P., Teixeira, A. J., Ryan, C. J., Burgwardt, F. H., DePlacido, P. A., & Pope, W. C. (2017). *Designing a Biomimetic Prosthetic Flipper for a Kemp's Ridley Sea Turtle*. Retrieved from <https://digitalcommons.wpi.edu/mqp-all/1244>

This Unrestricted is brought to you for free and open access by the Major Qualifying Projects at Digital WPI. It has been accepted for inclusion in Major Qualifying Projects (All Years) by an authorized administrator of Digital WPI. For more information, please contact digitalwpi@wpi.edu.

Author

Andrew Parker Dunne, Aryelle Jaclyne Teixeira, Christopher James Ryan, Frederick Harmon Burgwardt, Paul Anthony DePlacido, and William Clark Pope



WPI

Designing a Biomimetic Prosthetic Flipper for a Kemp's Ridley Sea Turtle

A Major Qualifying Project Report submitted to the Faculty of the
WORCESTER POLYTECHNIC INSTITUTE
in partial fulfilment of the requirements for the Degree of Bachelor of Science.



By:
Frederick Burgwardt
Paul DePlacido
Andrew Dunne
William Pope
Chris Ryan
Aryelle Teixeira

2016/2017
Submitted to
Professor Brian J. Sivilonis
Biomedical Engineering Department
Mechanical Engineering Department

Table of Contents

Acknowledgements	5
Abstract	6
Executive Summary	7
Table of Figures	9
1. Introduction	11
2. Literature Review	12
2.1 Overview	12
2.1.1 Flipper Amputation in Sea Turtles	13
2.2 Turtle Biology	13
2.2.1 Flipper Anatomy	13
2.2.2 Muscular System	14
2.2.3 Skeletal System	14
2.3 Sea Turtle Locomotion	15
2.3.1 Lift Forces	16
2.3.2 Powerstroke	16
2.3.3 Routine Swimming	16
2.4 Human Prosthetics	17
2.4.1 Materials	17
2.4.1.1 Silicone	17
2.4.1.2 Polyurethane	17
2.4.1.3 Copolymer	17
2.4.1.5 WinteresGel	18
2.4.2 Methods of attachment	18
2.4.2.1 Suction suspension prosthesis	18
2.4.2.2 Vacuum Suspension	18
2.4.2.3 Shuttle lock prosthesis	18
2.4.2.4 Straps and harness	19
2.4.3 Human Flipper design	19
2.5 Animal Prosthetics	20
2.5.1 Allison and Hofesh's Prosthetic Rudder System	20

2.5.2 Yu Chan's Prosthetic Flippers	22
2.5.3 Winter's Prosthetic Tail	23
2.5.4 Lola Prosthetic Flipper Design Project	24
3. Design Chapter	26
3.1 Client Statement	26
3.2 Existing Need	26
3.3 Engineering Problem	26
3.4 Design Criteria	26
3.5 Engineering Design Standards	26
3.6 Initial Designs	27
3.6.1 Jacket Design	27
3.6.2 Glove Design	28
3.6.3 Loop and Plate Design	28
3.6.4 Vacuum Design	29
3.6.5 Evaluation of Preliminary Designs	30
3.7 Manufacturing of Designs	32
3.7.1 Flipper Blades	32
3.7.2 Glove Design	34
3.7.3 Loop and Plate Design	36
3.8 Testing	38
3.8.1 Deflection Testing	38
3.8.2 Pressure Testing	40
3.8.3 Water Testing	45
3.9 Final Design	46
3.9.1 Grommet Lock Design	46
3.9.2 Manufacturing of Grommet Lock	49
4. Field Testing	50
4.1 Loop and Plate Design	50
4.2 Shuttle Lock Design	50
4.3 Grommet Lock	51
5. Final Design Validation	53
5.1 Manufacturability	53

5.2 Sustainability	53
5.3 Ethical Concerns	53
5.4 Health and Safety Issues	53
5.5 Economics	53
5.6 Environmental Impact	54
5.7 Societal Impact	54
5.8 Political Ramifications	54
5.9 Knowledge of Contemporary Issues	54
6. Conclusion	55
7. Recommendations	56
References	57

Acknowledgements

Our group would like to thank our advisor Professor Brian Savilonis for his tremendous support and guidance throughout the entirety of this project, as well as other members of the Worcester Polytechnic Institute Mechanical Engineering Department specifically Barbara Furhman and Peter Hefti for their help in ordering materials and creating our prototypes. We would also like to thank our sponsor, The Key West Aquarium, for giving us the opportunity to work on a project with one of their sea turtles. We want to specifically mention Greg Gerwin and Dr. Doug Mader from the Key West Aquarium for all of their help providing great feedback on our designs as they were developed and detailed responses on how our prototypes worked as they were tested at the aquarium. Lastly, we would like to thank Maria Suhl from Hanger Prosthetics in Worcester, MA and staff members at Coyote Design Orthotic & Prosthetic Technologies for their generous help in our manufacturing process.

Abstract

Lola, a Kemp's Ridley sea turtle located at the Key West Aquarium, has an amputated right pectoral flipper that causes her to swim inefficiently. A previous WPI team developed a first generation prosthesis to imitate Lola's healthy flipper. Our team focused our efforts on creating a lightweight, durable attachment that minimized application time and aligned properly to the residual limb. Our group developed a variety of designs to address these goals, communicated these ideas to the aquarium personnel, and sent prototypes to be tested on Lola. A final design was created in order to maximize the effectiveness of the device, while maintaining the biomechanics of the original flipper design. The final prosthesis attaches securely and easily and provides Lola with the ability to swim evenly and effectively. This work created a foundation that can be applied to other amputee turtles in order to improve their quality of life.

Executive Summary

Our team was tasked with the goal of designing an attachment method for a sea turtle's prosthetic flipper. We researched four different concepts to improve the attachment of the fin to the residual limb. These included: a jacket and harness combination, a loop and plate attachment, a glove attachment, and utilizing a one-way valve.

Lola's veterinarian, Dr. Doug Mader, discredited the jacket and harness design, as it would not have been feasible due to the amount of time it would need to be left on her. The one-way valve design was also dismissed due to its complexity. Once we had narrowed our design ideas to the Loop and Plate method and glove attachment, we moved forward with designing and manufacturing the two different, functional prototypes.

The Plate of the first attachment was 3D printed, while the Loop was made from a Velcro strap with sewn in neoprene. To construct the glove design, Mold Star 15 Slow was used to make a positive of the attachment socket. Then, using Smooth Cast 325, we created the socket that would attach to Lola's stump. Before the prototypes were sent to the aquarium for field-testing, proper baseline tests were performed. Pressure testing, weight comparison, and water simulation tests were conducted.

After receiving feedback on Lola's experience with both prototypes, it was determined that alterations would need to be made to the prosthesis to allow Lola to have a normal life. The glove design performed better than the Loop and Plate attachment both in speed of application and ease of achieving the proper alignment. For these reasons, the Loop and Plate attachment design was dismissed. The main concerns that needed addressing with the glove attachment method were its weight and length.

In the next iteration of the design, the glove was molded with Featherlight, which is a lightweight plastic generally used for fishing lures and large plastic sculptures. In addition to using Featherlight, we used a modified design that allowed the final length of the prototype to be adjusted. After performing baseline performance tests that were similar to what Lola would be subject to in the wild, the final attachment was sent and tested on Lola.

From our tests, we found the pressure on the skin to be very minimal. The final design produced a maximum point pressure of approximately 10 kPa, ensuring that the attachment method would not lead to pressure sores on any area of the limb. The final design weighed 305 grams, which is close to the first generation design from the previous project that weighed 286 grams. During the pool simulation test, the attachment method remained securely attached throughout all the motions it was subject to. The final design passed the pressure test and the pool simulation, while only adding nineteen grams to the overall weight of the design.

After shipping the final design to the aquarium, the aquarium provided information on fin performance on Lola. The time of attachment was reduced from ten or more minutes in the last generation's design, to two or three minutes using the current prosthesis. Additionally, achieving proper alignment of the prosthesis to the stump is much easier with this new model. These design goals were accomplished, while increasing the overall weight of the device by less than 10%, which had negligible effect on the performance of the turtle.

The only alteration that needed to be made to the device after it was field-tested was a 1cm semicircle cut around the elbow area to reduce rubbing. Future recreations of this design could be improved by angling the collar of the prosthesis away from the elbow to reduce contact in this area.

With a design that has now been optimized and proven to be successful on a living animal, this prosthesis could be recreated to help other amputee turtles. If simple adjustments are made to the sizing of the 3D printed piece, then the stump model of any specific turtle can then fit into the negative of the mold in order to create a customized prosthetic for the animal. By recreating the manufacturing methods with this slight change, we believe that this device can significantly impact the sea turtles fight against extinction.

We were able to design an entirely new method of attachment that attaches more quickly, aligns properly on a consistent basis, and only added nineteen grams of weight to the design in order to improve Lola's swimming ability and provide her with a better quality of life.

Table of Figures

Figure 1: Pectoral muscles of a sea turtle after removal of the outer shell [12]	15
Figure 3: One example of shoulder strap and harness prosthetic attachment [9].	19
Figure 4: Neptune design to aid amputees while swimming [17].	20
Figure 5: Allison's Plywood Prosthesis [18].	21
Figure 6: (L to R) Carbon Fiber Prosthetic, Ratchet Clamp, Neoprene Wetsuit [18].	21
Figure 7: Hofesh's Prosthetic [19]	22
Figure 8: Yu's Prosthetic Flippers [18].	22
Figure 9: Winter's Prosthetic Tail [20]	23
Figure 10: Defining a function flipper prosthesis for Lola [21].	24
Figure 11: Initial Jacket Design Concept.....	27
Figure 12: Initial Glove Design Concept.....	28
Figure 13: Initial Loop and Plate Design Concept.....	29
Figure 14: Initial Vacuum Design Concept.	30
Figure 15: Data from weighted design matrix.	32
Figure 16: Negative mold of the 3D printed flipper blade.....	33
Figure 17: 3D printed flipper blade; Smooth-Sil 945 flipper blade; Smooth-Sil 950 flipper blade.	34
Figure 18: The 3D printed piece used to create the mold for the final design.....	34
Figure 19: 3D printed cap of the Flipper Blade.	36
Figure 20: Final two glove designs and the sleeve.	36
Figure 21: 3D Printed Loop and Plate part.	37
Figure 22: Completed Loop and Plate Designs.	38
Figure 23: Flipper made of Smooth-Sil 950 deflecting 1.5 inches.	39
Figure 24: Flipper made of Smooth-Sil 945 deflecting 1 inch.	39
Figure 25: Flipper currently being used at the aquarium deflecting 1 inch.	40
Figure 26: Calibration Testing Results.	41
Figure 27: Setup for pressure testing.	41
Figure 28: Location of the sensors on the stump.	42
Figure 29: Two different sensors we used to assure the results were reasonable.....	42
Figure 30: Pressure testing of Loop and Plate Design.	43
Figure 31: Setup for pressure testing on glove design.	44
Figure 32: Water testing of the final Glove Design.	46
Figure 33: Grommet Lock From Coyote Design.....	47
Figure 34: Flipper Blade Adjustments.....	48
Figure 35: Lock Position Adjustments.	48
Figure 36: Screenshot of CAD model for new design.	48
Figure 37: (T-B) Loop and Plate Design, Shuttle Lock Design, and Previous Design Prostheses Lengths.....	51

Table of Tables

Table 1: Definitions and weights of criteria used in the weighted design matrix.....	30
Table 2: Results from the pressure testing on the final Glove Design.....	44

1. Introduction

Sea turtles are one of Earth's most ancient creatures. The seven species that still exist today date back to when dinosaurs roamed the Earth, 110 million years ago [1]. Under the Endangered Species Act (ESA), sea turtles are classified as endangered. The ESA provides protection to all threatened and endangered sea turtles found in US waters [2]. Although sea turtles are protected under the ESA, there are still many threats to the sea turtle population. These threats include, but are not limited to: predator attacks, vessel strikes, netting captures, destruction and alteration to feeding and nesting sites, and entanglement in aquatic debris. The decline in sea turtle population negatively affects aquatic ecosystems, and therefore they should be a priority to protect.

Amputation of a flipper can alter a turtle's life indefinitely, and often occurs from many of the threats previously referenced. The turtle cannot perform various common tasks such as efficient swimming and mating. Therefore, a proper prosthesis would need to be made in order for the turtle to live a more normal life. For an endangered species, every individual is crucial to the survival of the group, so a prosthesis that could allow a turtle to reproduce could turn the tide of extinction.

Lola is a Kemp's Ridley sea turtle that has an amputated right pectoral flipper due to a shark attack. Therefore, Lola has trouble swimming in straight lines and is unable to mate currently. The way Lola swims also has put significant strain on her left flipper, which would need to be rectified in order to allow proper swimming technique and mating.

Previously, a WPI project team worked to create a prosthetic that was implemented on Lola to help improve her way of life. The team has helped develop a way for us to improve their original design by enhancing the attachment method, which had led to some unforeseen difficulties. These included the length of time it took to attach the prosthesis to Lola, incorrect alignment when the prosthesis was in use, and securement on Lola's residual limb.

Therefore, we set out our goals to fix these problems with a new attachment method. This would include providing a sleeve for Lola's stump, creating a socket (attachment piece) with the prosthetic fin inserted, and providing Lola with an overall more efficient prosthetic to make swimming and mating come naturally without any difficulties.

2. Literature Review

2.1 Overview

Sea turtles are one of Earth's most ancient creatures. The seven species that still exist today date back to when dinosaurs roamed the Earth, 110 million years ago [1]. Under the Endangered Species Act (ESA), sea turtles are classified as endangered. The ESA provides protection to all threatened and endangered sea turtles found in US waters [2]. Although sea turtles are protected under the ESA, there are still many threats to the sea turtle population. These threats include, but are not limited to: predator attacks, vessel strikes, netting captures, destruction and alteration to feeding and nesting sites, and entanglement in aquatic debris. Sea turtles are also in danger of being slaughtered for their eggs, meat, skin and shells.

2.1.1 Importance of Sea Turtles

The decline in sea turtle population directly affects marine ecosystems, specifically coral reefs and seabeds. Sea turtles eat seagrass, which allows seabeds to grow evenly along the seafloor instead of at an uncontrollable pace and keeps the seagrass healthy [3]. Healthy seabeds are ideal breeding grounds and development habitats for many species of marine animals including fish, crustaceans, and shellfish. If sea turtles were to become extinct, the amount of healthy seabeds and the amount of marine animals that breed and develop within them would decrease rapidly. As a result, the economy would be negatively affected because valuable marine animals live in these habitats.

Sea turtles also have a positive effect on ecosystems outside the ocean. A study conducted by the Department of Biology at the University of Central Florida determined that sea turtles positively impact beach dunes [4]. Sea turtles lay an average of 100 eggs during the nesting season. Unfortunately, not all the eggs hatch and not all hatchlings will survive the journey out of the nest into the ocean. The study determined that the eggs and hatchlings that do not survive provide key nutrients to vegetation, which in turn contributes to the maintenance and stabilization of coastal dunes. The shells of the hatchlings that do survive also provide nutrients to the dunes as well. Dunes play an important role to the beach ecosystems. The vegetation in the dunes grow roots and these roots help prevent erosion. If sea turtles cease to exist, the dunes will lack key nutrients to stay healthy and not be strong enough to maintain their integrity.

Sea turtles also have significance in tourism and in many religions and cultures. For example, an inner dimension of Islam, called Sufism, depicts sea turtles as a religious symbol [5]. Just as the sea turtle eggs hatch and the offspring return to the ocean, it is believed through Sufism that people return to god through god's guidance. Sea turtle shells are also used as ornaments and for ceremonial purposes in many cultures.

2.1.1 Flipper Amputation in Sea Turtles

With all the purposes that sea turtles serve, it is important for sea turtles to escape extinction. In order to do so, sea turtles have to stay safe and healthy long enough to mate. A key factor in this safety relies on its ability to perform common tasks. Many sea turtles suffer from injuries that lead to flipper amputations, and flippers are a crucial feature that allows sea turtles to perform these tasks. Predator attacks, netting and debris entanglement and boating collisions are some of the common incidents in which result in flipper amputation. Veterinarians generally decide to amputate the injured flipper for various reasons: the injury being irreversible, poor blood flow, and risk of infection [6].

Amputations can save the life of a sea turtle, but there are many consequences after the surgery. There are multiple sea turtles at the Key West Aquarium with amputated flippers. Lola is a Kemp's Ridley sea turtle with an amputated pectoral flipper; she is being cared for at the Key West Aquarium. After the amputation, Lola could not swim effectively and was only able to swim in circles. Lola, along with other amputees, attempts to compensate for the missing flipper by putting more stress on her other flippers, which is harmful in the long term. Sea turtles with amputated flippers suffer from buoyancy issues, drowning risks, and if set back into the ocean, predator attacks. After a sea turtle undergoes a flipper amputation surgery, the sea turtle is kept in captivity in order to keep it safe. There is also another important benefit from being in captivity; when the female sea turtles lay their eggs, the survival rate of the hatchlings is 80%. In the wild, the survival rate is only 10% [7].

2.2 Turtle Biology

In order to properly design a prosthetic flipper, it is important to have a thorough understanding of both the general anatomic makeup of a turtle's flipper, as well as the specific characteristics of the Kemp's Ridley and other common sea turtles. Sea turtles, like all other reptiles, are closed-circulatory system organisms made up of bone, tissue, and blood vessels. A defining physical characteristic of the Kemp's Ridley is its size. Kemp's Ridley turtle range only from 75-100 pounds. [8].

2.2.1 Flipper Anatomy

The flipper of the sea turtle is designed to provide powerful strokes through deep oceans through the combined design of their muscle layout and bone makeup. Sea turtle's muscles are stronger than those of terrestrial tortoises, and their joints are able to rotate and flex in order to swim long distances with ease [9]. Their flippers are composed of scaly skin on top of muscle tissue that surrounds their digit bones, which are elongated to provide extra power in motion [9].

All species of sea turtles have anatomies that are designed to allow them to swim long distances quickly, since a sea turtle's natural habitat is the ocean. However, an amputee turtle would never be released back into the wild for its own safety after being rescued, meaning that

its new home would be an enclosed tank. Amputations often result in the loss of muscle and bone groups for turtles. This could possibly affect something like a turtle's ability to produce lift or forward thrust with a stroke of its flipper. It could also affect its ability to rotate its limb to achieve a certain range of motion. Because of these factors, not all of the locomotive capabilities of a wild sea turtle need to be met with our prosthesis. Ultimately, the prosthetic device must allow the turtle to be mobile in the water, to surface, feed, dive down, and propel through the water.

2.2.2 Muscular System

The main functions of the muscles in a turtle's flipper are to flex, to provide motion, and to absorb the force sent through the body when in motion [11]. The skeletal muscles in the front flippers of turtles connect back into their shoulders, which contract to cause a stroke motion of the flipper through the water. Muscles that have been partially lost or damaged due to amputations will be weaker and unable to replicate normal activity [11]. Because extra work is required to move the prosthesis through the water, new levels of stress are introduced to the amputation site. This causes new cells to proliferate to the area where the muscle fibers are being strained [11]. Over time this will result in a generation of new muscle tissues at the amputation site, creating stronger muscles and allowing the turtle to use the prosthesis rather effectively.

The pectoralis major is one of the larger muscles in the front flipper, which, along with other deeper pectoral muscles, is responsible for a portion of the turtle's contracting and flexing motions [11]. The pectoralis muscles also control most of the rotational motion of the front flippers through the shoulders. Lola has retained portions of these muscles after her amputation, which she now uses to move and rotate her stump. Lola has lost some of the major muscles in her flipper post-amputation, which were important for the overall motion of her flipper. Her missing flexor and extensor muscles, which reach up to her carpals, metacarpals, and phalanges, would normally provide the ability to rotate her flipper at its tip.

2.2.3 Skeletal System

As with most organisms, the skeletal system of a turtle is designed to provide shape and structure for the muscles and tissues to interact around. The bones of the flipper are manipulated by the muscles through tendons, which connect the muscles to the bones [11]. The contraction of certain muscles will result in either the extension or adduction of the limb, generating the stroke motion.

The largest bone in the turtle's flipper is the humerus, which connects the limb to the shoulder joint [11]. This is the bone that Lola still has intact on her amputated flipper. The humerus is attached to the body of the turtle primarily through the pectoral muscles, along with some smaller adductor and extensor muscles. This bone-to-muscle interaction provides the majority of the powerstroke motion. Smaller muscle-to-bone interactions lead to more finite motor skills include the digits and phalanges. These interactions can rotate the flipper near its tip

to allow for more precise movement.

Figure 1 below displays the deep pectoral muscles of a sea turtle after the removal of the outer shell. These muscles are all used in the movement of a turtle; the two main muscle groups are the biceps brachii superficialis and supracoracoideus (posterior part), which are used to adduct and retract the flipper.

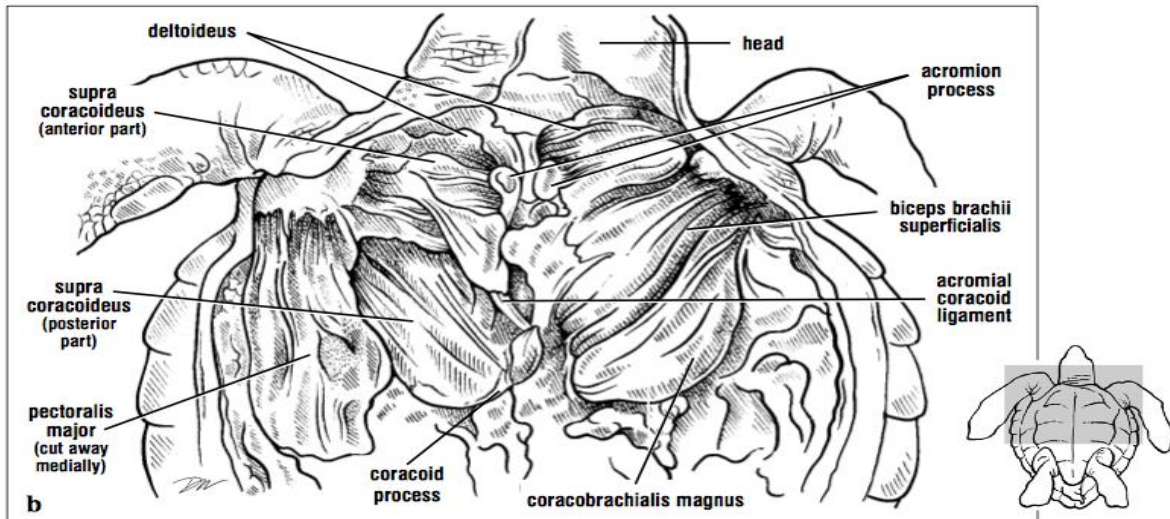

Figs. 112a and 112b. The deep pectoral muscles are exposed after removal of the pectoralis major. These forelimb retractors, separated on the animal's left (right in picture), are the biceps brachii superficialis and coracobrachialis magnus. The posterior part of the supracoracoideus both adducts and retracts the flipper.

Figure 1: Pectoral muscles of a sea turtle after removal of the outer shell [12]

The flipper itself is moved by the muscles in the sea turtle's shoulders and back; this allows us to create a stiff prosthetic flipper because the turtle we are working on still has parts of these muscles intact, allowing for the same range of motion of a non-injured sea turtle.

2.3 Sea Turtle Locomotion

Understanding how a sea turtle uses their front flippers for locomotion is essential for our team to properly design a useful prosthetic flipper. All four flippers of a sea turtle are used in locomotion to allow the turtle to move on land and sea. For this project, our focus is how sea turtles use their front flippers in water because Lola is missing a portion of her front flipper.

Sea turtle's front flippers are used to generate all of the power required to move, while their hind flippers are mainly used for steering. Front flippers are used synchronously when the turtle is moving in a straight line and one flipper will move faster than the other when the turtle is turning to either side. Sea turtles will also use their flippers to glide through the water and angle them in order to move up or down.

2.3.1 Lift Forces

Sea turtles will use their flippers at different angles to produce different lift forces and to direct their movement. Keeping their flippers horizontally allows the sea turtle to glide properly through the water while angling them up or down helps the turtle to move upwards or dive downwards similarly to the wings on an airplane.

2.3.2 Powerstroke

The powerstroke is the strongest and most powerful method of swimming for sea turtles. This process, which is pictured below in Figure 2, shows the locations of the flipper tip during regular swimming (a) as well as the angles of the flipper at regular swimming (b). Also pictured is the location of the flipper tip during vigorous swimming (c) and the flipper angles during vigorous swimming. Sea turtles held in captivity do not experience vigorous swimming because they are sheltered in small tanks.

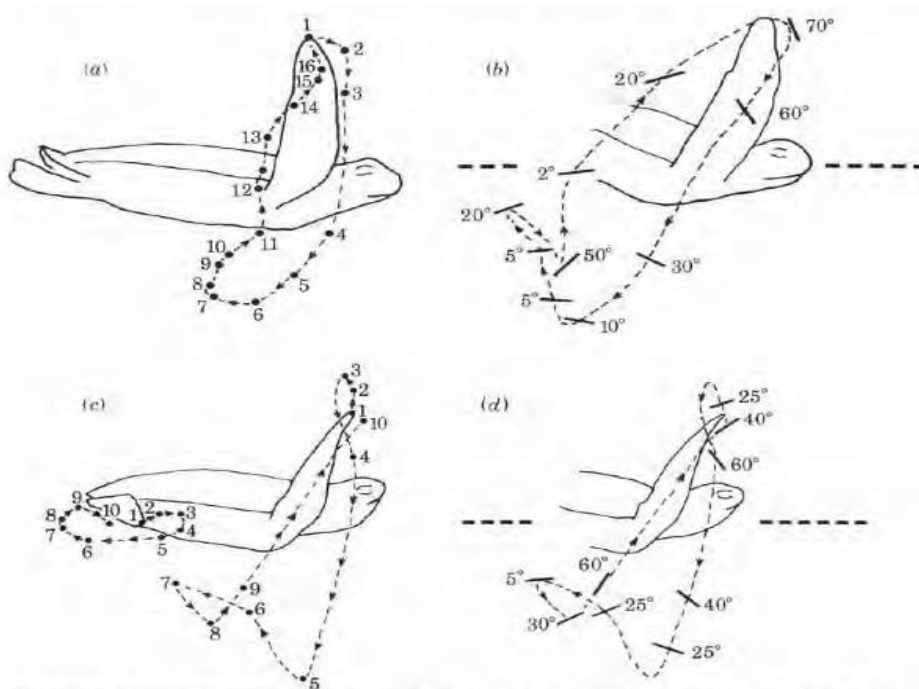

FIGURE 6. (a) Routine swimming sequence in *Chelonia mydas*. Position of blade tip at intervals of 0.087 s. (b) Routine swimming sequence in *Chelonia mydas*. Angle between blade of pectoral limb and horizontal during limb cycle. (N.B. This sequence was drawn from a different section of video film from that shown in figure 6a). (c) Vigorous swimming sequence in *Chelonia mydas*. Positions of tips of right pectoral and pelvic limbs at intervals of 0.087 s. (d) Vigorous swimming sequence in *Chelonia mydas*. Angle between blade of pectoral flipper and horizontal during limb cycle.

Figure 2: Routine and Vigorous Swimming [13]

2.3.3 Routine Swimming

A typical turtle in the wild will swim at an average cruising speed of roughly one to three

mph and can reach speeds of up to twenty mph in quick bursts to escape predators. Routine swimming for turtles in captivity will result in much less stress and power than a turtle in the wild. Lola will be spending all of her time in a tank that is roughly 816 cubic feet. Therefore, she will not reach speeds comparable to speeds reached by sea turtles in the wild. However, her captivity will provide her prosthesis with other stresses, such as forces acting against it as it strikes the side of the tank.

2.4 Human Prosthetics

The field of turtle prosthetics is a relatively uncharted territory. There are few examples of functional turtles prostheses in the world. However, there are countless examples of human prostheses, which operate under various mechanisms. Research of human prostheses will give us a better understanding of how these prostheses perform and how they could be potentially modified and applied to turtles.

2.4.1 Materials

The best method to ensure a secure fit in human prosthetics is to utilize liners, which are thin sleeves that fit over the residual limb, allowing for a reduction of chafing and unhindered movement of the prosthesis [14]. There are several types of liners that are made out of various materials and cater to different situations. The potential materials are: silicone, polyurethane (PUR), Copolymer, and WintersGel.

2.4.1.1 Silicone

Silicone is widely used in human prosthetics as a liner. It provides good stability and adhesion, which is useful for soft tissue applications. In addition, silicone is a soft, cushioning material, which absorbs and distributes pressure, and is easy to clean. It is generally recommended for individuals with low to moderate activity levels [14].

2.4.1.2 Polyurethane

Polyurethane or PUR, is a commonly used prosthetic sleeve that has many advantages. A PUR sleeve has the ability to flow away from high pressure, meaning the pressure in the socket of the prosthesis would be well distributed across the entire sleeve. PURs characteristics and damping of pressure on the effected limb would make it a good choice for sensitive, bony or scarred residual limbs. PUR is best suited for individuals from low to especially high activity levels [14].

2.4.1.3 Copolymer

A copolymer or a thermoplastic elastomer is another liner that is typically used in the prosthetics field. This type of liner is best suited for individuals who will use it for low levels of activity [14]. This material does not have seams that could separate after prolonged use,

increasing longevity of the material. Copolymers are more elastic allowing for fitting of more asymmetric residual limbs [14].

2.4.1.5 WintersGel

WintersGel was specifically designed for a dolphin named Winter. Dolphins have more sensitive skin than humans. Even though the material was produced for dolphins, it has been used in humans for any amputee seeking a more comfortable alternative to traditional liners [15]. Since this material was designed for aquatic mammals, it can withstand the harsh saltwater environment. WintersGel, as well as the other common liner materials all still have potential drawbacks caused by perspiration issues, hygiene concerns, lack of breathability and potential skin breakdowns. However, the benefits of the liner outweigh any of the potential drawbacks.

2.4.2 Methods of attachment

To gain a better understanding of how our prosthetic attachment may work, we will look into how human prosthetics attach to the body. The typical attachment methods are suction suspension, vacuum suspension, and shuttle lock prosthesis.

2.4.2.1 Suction suspension prosthesis

This attachment method uses the weight of the patient standing on the connection to expel the air in between the socket and the liner [15]. This type of prosthesis attachment is generally used for people who have leg amputations. This method requires two different kinds of sleeves, a silicone sock that is placed on first to create the seal for the suction. Then a prosthetic sock is placed over the silicone sleeve for increased comfort [15]. With every step the user takes, any excess air gets expelled from the socket creating a secure attachment.

2.4.2.2 Vacuum Suspension

A vacuum socket uses the suction of a vacuum to hold the prosthetic onto the limb of the patient. This vacuum is created by the seal that is created between the limb liner and the edge of the socket on the prosthesis. An exhaust valve can remove all the air in between the socket and the limb liner, creating the vacuum holding the prosthesis to the limb [15]. This prosthetic connection method is one of the most comfortable available as the vacuum evenly distributes the force across the entire surface area of the socket [15].

2.4.2.3 Shuttle lock prosthesis

This method of prosthesis connection utilizes a padded liner, with a plunger on the end. This plunger then connects into the prosthesis' socket side, which is a one-way locking device, preventing the prosthesis from falling off the limb. To remove the prosthesis, simply press a button on the side releasing the plunger from the one-way lock. This type is one of the easiest methods to attach and detach; however it is designed for people who have low activity level [15].

In high activity scenarios the shuttle lock method can lead to blisters or sores due to the connection, which allow rubbing on the limb to occur.

2.4.2.4 Straps and harness

There are many types of strap and harness systems for human arm prostheses; however they all share the same basic design. The strap system holds the prosthesis into place by wrapping around the shoulder then underneath the arm on the other side of the body. This attachment method holds the prosthesis securely to the limb. In figure 3 below, there is an example of this kind of prosthetic attachment. Some designs of this kind of prosthetic attachment include cables that are able to open and close a device where the hand would be [16].

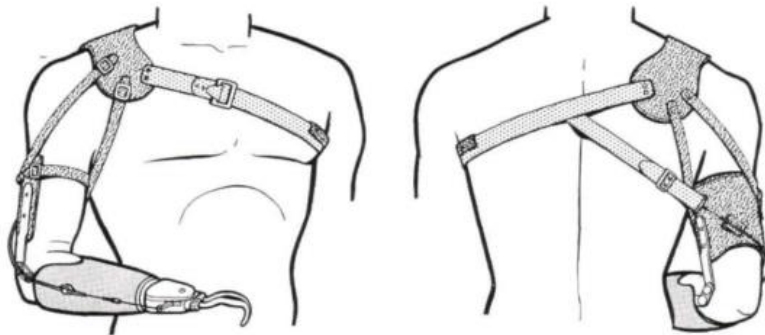

Figure 3: One example of shoulder strap and harness prosthetic attachment [9].

2.4.3 Human Flipper design

A Swedish designer has come up with the Neptune concept, which, as seen in Figure 4, utilizes a fin and a prosthetic attachment to enable amputees to swim. This flipper design utilizes a silicone sleeve that attaches to a distributing cup that connects the sleeve to the actual prosthetic. In addition to the distributor cup, there are limb supports that fit over the limb to provide extra support [17]. Another fin design used for amputees who want to swim utilizes a vacuum socket to connect the prosthetic to the limb. This connection provides a “pain free swimming” experience, as the vacuum method described above is the most comfortable connection method [18]. These methods of attachment have proven to be successful in the field of human prosthetics and may be modified and applied to turtle prosthetics.



Figure 4: Neptune design to aid amputees while swimming [17].

2.5 Animal Prosthetics

Animal prosthetics is a novel field, especially in the case of aquatic animals. Of these animal prosthetics, there are even fewer cases of prosthetic flippers being designed for turtles with amputated flippers. Currently, there are only four turtles in the world that have received some type of prosthesis and only two turtles which have received a flipper prosthesis, including Lola. These cases create a baseline in the development and creation of turtle prosthetics.

2.5.1 Allison and Hofesh's Prosthetic Rudder System

Allison, a Green sea turtle, lost a pectoral flipper and both of her pelvic flippers in a shark attack. Allison was unable to surface for air in pools deeper than 2 feet and could only swim in circles. An intern at the turtle rehabilitation center where Allison is located designed a rudder system for her that mimics a canoe paddling technique and allowed her to maneuver better [18]. In this paddling technique, a canoe can be propelled forward by rowing one paddle on one side of the canoe and by trailing another paddle to create drag. Allison's prosthetic rudder similarly creates drag and allows her to propel herself forward with her remaining pectoral flipper [18].

The first prototype of Allison's prosthetic flipper included a neoprene wetsuit covering the majority of her shell, which stabilized the attached plywood rudder, shown in Figure 6 [18]. Allison's prosthetic was altered later to minimize buoyancy effects caused by the plywood. A carbon fiber rudder was manufactured that uses a clamp mechanism to grip about Allison's shell. This design uses a ratchet system to secure the prosthesis to Allison, as shown in Figure 5. The

prosthetic device is fixed and remains stationary while in use, and therefore requires little maintenance. However, this device does not provide Allison with any additional thrust.



Figure 5: Allison's Plywood Prosthesis [18].



Figure 6: (L to R) Carbon Fiber Prosthetic, Ratchet Clamp, Neoprene Wetsuit [18].

Hofesh, another Green sea turtle, developed a similar problem as Allison after being caught in a fishing net. This accident required both his left pectoral and pelvic flippers to be amputated [19]. A prosthetic was designed for Hofesh, which included a plastic dual tailfin, as seen in Figure 7. This fin allowed Hofesh to have better hydrodynamic stability and also helped him to surface for air and food. Much like Allison's prosthesis, Hofesh's design increased his mobility and balance in the water. However, the device could not produce any thrust to aid Hofesh in propulsion.



Figure 7: Hofesh's Prosthetic [19]

2.5.2 Yu Chan's Prosthetic Flippers

The first example of a sea turtle with prosthetic flippers came from a Japanese loggerhead sea turtle named Yu Chan. This turtle lost half of her left pectoral flipper and a third of her right pectoral flipper from a shark attack. After numerous iterations, Yu was given a prosthesis, which consists of two artificial flippers that are attached to a soft vest, which fits over her shell, shown in Figure 8 [18]. The prosthetic flippers are fixed in place by the vest and a series of adjustable straps and protect the amputation sites.



Figure 8: Yu's Prosthetic Flippers [18].

Unlike the Allison and Hofesh's prostheses, Yu's flippers provide additional thrust because they expand the span of each flipper. This larger span, however, also increases the risk of Yu accidentally hitting other objects and may hinder her movement through more difficult terrain, such as through seaweed or other vegetation. Additionally, Yu's prosthetic flippers do not function like natural flippers because they do not utilize her natural lift-based mechanism. The flippers instead act more similarly to rowing paddles. Compared to natural flippers, this increases her drag and reduces control.

Yu's case is unique because she was missing both pectoral flippers, meaning that the

prosthetic flippers were not required to replicate the motion of another remaining pectoral flipper. The attachment of two identical pectoral flippers also allowed Yu to have improved balance compared to turtles with one prosthetic pectoral flipper and one natural pectoral flipper. These issues of balance and mirrored locomotion are greater factors in turtles without dual pectoral flipper amputations.

2.5.3 Winter's Prosthetic Tail

Winter is a dolphin that became entangled in the line of a crab trap, which cut off the circulation to her tail flukes, thus requiring amputation. Because dolphins use their tails for propulsion, the loss of Winter's tail decreased her mobility and caused her to adopt a different motion in an effort to propel herself forward, which was causing additional damage to her skeletal system.

For this reason, the first dolphin's prosthetic tail was developed for Winter, as seen in Figure 9. This tail consists of a tail, fluke, and joint. To attach the device to Winter, she is first fit with a type of silicone sleeve, made from a material called WintersGel that was specifically designed for Winter's purpose. This sleeve is very similar to sleeves used in human prosthetics. The prosthesis is then fit over the sleeve, with the fluke friction fitting to her peduncle [20].

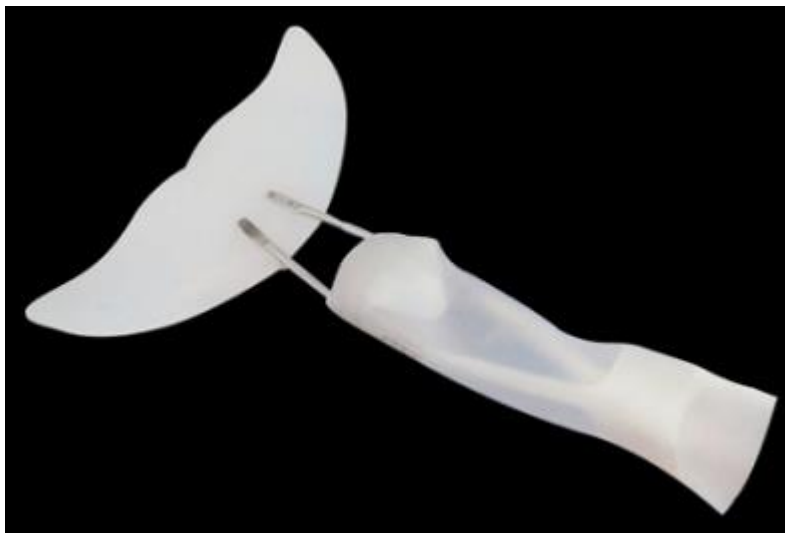

Figure 9: Winter's Prosthetic Tail [20]

Winter's prosthesis, although not a turtle prosthesis, provides valuable information in terms method of attachment. Her prosthetic sleeve allows for increased comfort compared to straps and buckles typically used as methods of attachment. This sleeve also provides enough friction to firmly attach the fluke of the prosthetic to Winter's peduncle even while she uses the prosthetic to propel herself forward, demonstrating that it is a successful technique.

2.5.4 Lola Prosthetic Flipper Design Project

In 2015, a team of students from Worcester Polytechnic Institute set out to “create a low-cost, safe prosthetic that improves [a] turtle’s ability to generate propulsive forces” [21]. The project focused in particular on providing a right pectoral flipper for a female Kemp’s Ridley sea turtle named Lola. Lola lost the majority of her limb to a shark attack and now has hindered swimming capabilities. The prosthetic flipper project sought to provide an aid for Lola to help her swim more effectively. The parameters that the previous project team used to collectively define a functional aid for more effective swimming are outlined in Figure 10 [21].

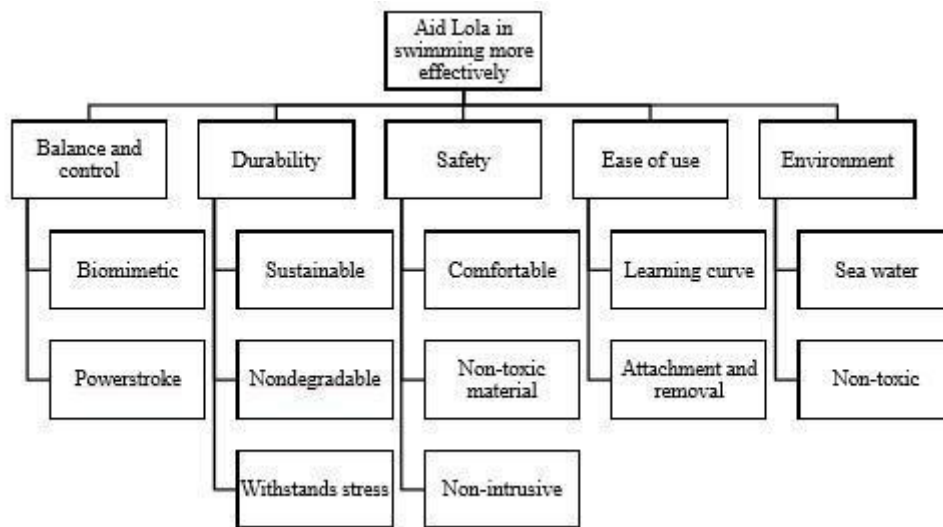

Figure 10: Defining a function flipper prosthesis for Lola [21].

The prosthetic flipper was split into two components [21]. The first component was the flipper blade. The flipper blade was acceptable for balance and control because the design had aerodynamic performance that generated the correct powerstroke that, in turn, provided the necessary biomimetic qualities. Although the flipper design provided the necessary lift and thrust forces for a full powerstroke, Lola merely glides around her tank so when the prosthetic was implemented, a full powerstroke was not required. The flipper blade was sufficiently durable because the chosen materials were sustainable, nondegradable, and long lasting. Because the theoretical mechanical failure stress of the flipper blade is greater than the maximum stress Lola’s prosthesis would experience during the powerstroke, her current prosthesis is expected to have a long lifetime. In addition, the flipper blade was adequately safe because the material was non-toxic to Lola, the blade was not intrusive to the rest of her body, and the prosthesis was comfortably sized to match her other flipper. The blade provided a desirable ease of use as well because it was sized to match the remaining pectoral flipper, accelerating Lola’s learning curve. Finally, the blade was resilient and non-toxic to Lola and the saltwater environment. All in all, the first component, the flipper blade, was sufficiently functional.

The second component of the prosthetic flipper was the attachment system [21]. When secured, the attachment system allowed the prosthesis to add proper biomimetic and powerstroke qualities. The durability of the attachment system was satisfactory because the selected material was nondegradable. However, the system could not withstand the stress of some swimming motions and would fall off or rotate out of proper alignment during live testing. Overall, the safety of the attachment system was poor because although it was non-toxic material to Lola, it was determined to be intrusive and uncomfortable to Lola in live testing. She developed several calluses and sores while wearing the device. Additionally, the ease of use was also poor because the attachment system made the attachment and removal of the prosthetic flipper difficult for Lola's human handlers in live testing. As for the environment, the attachment system was both resilient and non-toxic to the seawater environment. When all is considered, the attachment system did not meet the defined parameters to be defined as functional.

When looking at this success of this project, it is best to look at two components independently. Based on the parameters the team set out, they were successful in creating a functional flipper blade. On the other hand, the attachment system fell short of a few crucial parameters they set out for the project. Several improvements could be made to the system, such as: reducing the time required to attach and remove the device, allowing for a comfortable fit to reduce callus formation, and creating a mechanism that would ensure a secure fit without allowing the device to rotate about the residual limb.

3. Design Chapter

3.1 Client Statement

Our goal with this project was to create a turtle flipper prosthetic that was made custom for Lola, but could also be adapted to fit any amputee turtle if altered slightly. The device made for Lola would be thoroughly tested both in-house and in the field after being sent to the aquarium, so that it could be fully optimized according to both Lola's needs and the usability of those applying it to her.

3.2 Existing Need

The need for this device stems from the aforementioned fact that many species of sea turtles are endangered. Because many of the things that are causing their endangerment cannot be prevented, such as boating accidents and predator attacks, another way to help this situation is to give the amputee turtles that survive these incidents prosthetic flippers to aid in their rehabilitation. On top of that, amputee turtles are unable to mate to reproduce, because they have to be kept in singular confinement from other turtles in order to not further decrease their quality of life by having them interact with healthy turtles. Therefore, by giving an amputee turtle a prosthetic to improve its quality of life, it then could be put back with other members of its species, then allowing it to hopefully reproduce so that its babies could be released into the wild. There is no current device in existence that accomplishes this by only attaching to the residual limb.

3.3 Engineering Problem

The engineering problem that defines this project is how to create a turtle flipper prosthetic that both mimics the biomimetic locomotion of a healthy flipper and has a high enough usability so that the device can be easily applied to the turtle quickly and in the correct orientation.

3.4 Design Criteria

The criteria that the designs were evaluated on were performance, ease of attachment, safety, durability, manufacturability, and cost. These criteria were also defined in Table 1.

3.5 Engineering Design Standards

The two main types of engineering design standards that would need to be considered in a project such as this would be industry drafting standards and ethical standards. SolidWorks is considered a universal tool in industry drafting standards, which would allow for it to be used and accepted by the majority of those intending to manufacture the design. It follows Military-

Standard-31000A, ASME Y14.41, ISO 16792, and DIN ISO 16792 [24]. Considering ethical standards, because safety of both all those working on and testing the device will be the top priority, no ethical standards seem to be of concern.

3.6 Initial Designs

Initially, we developed four comprehensive prosthetic flipper attachment concepts. One concept used a jacket/harness that completely encompassed the sea turtle's body to secure the prosthetic flipper to what is remaining of the turtle's limb. Another concept involved a custom fitting glove, which incorporated a pushpin lock to secure the flipper to the turtle's limb. An additional idea attached the prosthetic flipper to a flat plate for the base of the residual limb and a strap that would loop around the limb and secure it to the plate. The last design implemented dual silicon sleeves and a one-way valve between the two sleeves that would secure the flipper to the residual limb with vacuum suction.

3.6.1 Jacket Design

The first of the four designs was the Jacket Design, which includes a jacket made of a neoprene material. This jacket fastens around the turtle's shell using buckles. The prosthesis is permanently attached to the jacket using rivets and other fastening mechanisms. Soft silicone and rubber materials are sewn onto the underside of the neoprene jacket to create additional friction between the neoprene jacket and the turtle's shell (Figure 11).

The major benefit to this design was its ability to distribute the pressure from the prosthesis to other parts of the turtle's shell, thus reducing the local pressure. Also, this design provided ease of attachment, with only two snap buckles as points of attachment. However, this design concept was ultimately abandoned as the Aquarium expressed their concerns of the turtle's acceptance of the jacket system.

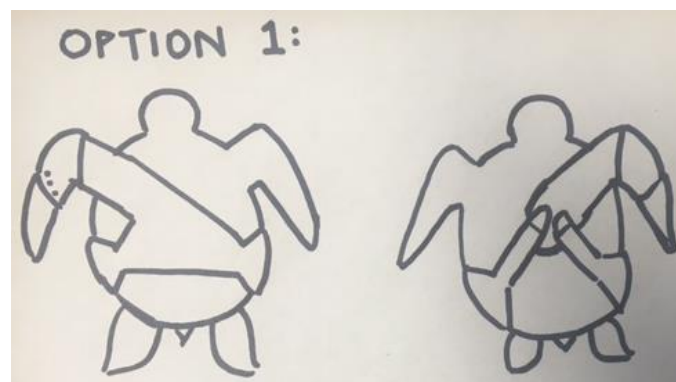

Figure 11: Initial Jacket Design Concept.

3.6.2 Glove Design

In the second design, the Glove Design has the prosthetic flipper riveted to an attachment glove. The attachment glove has a prosthetic push pin lock incorporated into it as the securement method. A silicon sleeve with the pin end for the pushpin lock goes on the residual limb. The sleeve and glove pushpin lock system secures the flipper to the turtle (Figure 12).

The main appeal of this design is that the attachment glove is customized for the specific residual limb in question. In order to create the attachment glove, CAD software is used to create the custom mold that will adhere to the dimensions of the specific residual limb. Another strength of the design is that the pushpin lock and silicon sleeve are already produced and used for human prosthetics. This means the locking mechanism has a history of success for prosthetics, an easy method to secure and release, and simpler manufacturing since it is commercially available.

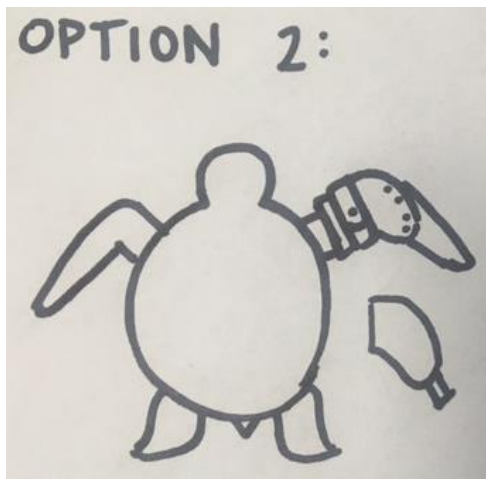

Figure 12: Initial Glove Design Concept

3.6.3 Loop and Plate Design

The Loop and Plate design has the prosthetic flipper riveted into a flat plate. The flat plate has neoprene straps built into it that are looped over the residual limb and pulled taught. Hence this design is called the Loop and Plate design. A silicon sleeve goes over the residual limb prior to having the loop and plate secured to it (Figure 13).

The key design feature is the ability to align the flat base of the residual limb with the flat plate which, in turn, gives the flipper itself the proper orientation. In addition, the combination of the silicon sleeve and neoprene strap provides desirable friction while still being comfortable for the turtle. Additional appeal of this design is that it can be applied to many different turtles with

minimal adjustments.

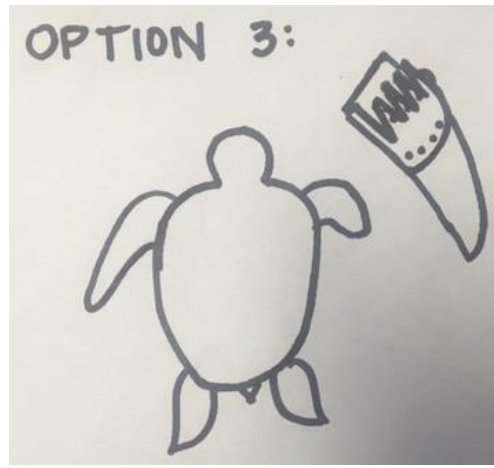

Figure 13: Initial Loop and Plate Design Concept.

3.6.4 Vacuum Design

The final design idea implements dual sleeves and a one-way valve between the two sleeves that secure the flipper to the residual limb with vacuum suction. The flipper blade is attached to one of the sleeves in an airtight manner, using glues and resins that are saltwater compatible to create a seal. The one-way valve is located on the sleeve that is attached to the flipper blade. A sleeve that is fitted to Lola's residual limb is also used in this design. To attach the device to Lola, the fitted sleeve is first applied to her stump. The secondary sleeve with the attached flipper blade is then applied over the fitted sleeve. A vacuum is then used on the one-way valve to eliminate any air in between the two sleeves and to create an airtight design (Figure 14).

The main appeal to this design is its custom nature. The prosthesis is custom fitted to Lola's stump and changes in her stump, such as calluses or increased muscle mass, do not inhibit the design in any way. Additionally, with a vacuum-sealed design, the flipper blade cannot rotate about her stump and slip due to the increased friction between the dual sleeves and its airtight nature. The biggest concern with this design is the one-way valve and its interaction in a seawater environment, especially at deeper depths, when the atmospheric pressure increases.

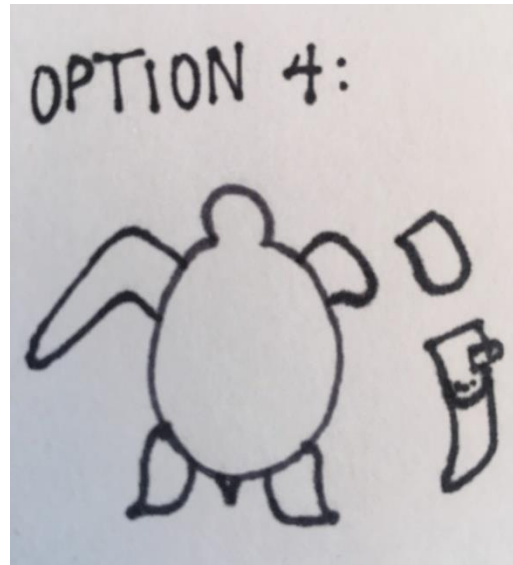

Figure 14: Initial Vacuum Design Concept.

3.6.5 Evaluation of Preliminary Designs

Moving forward, we wanted to focus our efforts on the best design concepts. In order to determine this, we constructed a design matrix that considered all the features the product required. These features were performance, ease of attachment, safety, durability, manufacturability, and cost. However, some of these features were more crucial to the product so each feature was assigned a weight on a 1-10 scale of how important it was to the product. The features of each criterion were clearly and understandably defined below in Table 1.

Table 1: Definitions and weights of criteria used in the weighted design matrix

Criteria	Weight	Definition
Performance	10	The design provides proper alignment and securement on the stump while allowing forward movement
Ease of Attachment	8	The design is easy to attach to the turtle in a short amount of time
Safety	7	The design does not cause harm to the turtle or its

		environment
Durability	6	The design will last a long period of time in an aquarium environment
Manufacturability	6	The design is easy to manufacture and replicate for other turtles
Cost	4	The design will be cost effective

Using the weighted design matrix, each member of our team individually rated on a scale of 1-10 how well he/she thought the design in question adhered to the criteria. Using the data from the design matrix, we determined the top 3 designs to pursue were Loop and Plate, Glove, and Jacket/Harness. The data from the weighted design matrix is below in Figure 15.

Criteria	Weight	Design					
		Jacket / Harness					
		EB	PD	AD	WP	CR	AT
Performance	10	7	8	8	7	7	8
Ease of Attachment	8	5	4	4	6	4	6
Safety	7	8	9	6	8	9	9
Durability	6	7	8	7	7	8	8
Manufacturability	6	7	7	7	7	7	6
Cost	4	9	5	6	8	6	6
Total		286	285	262	290	279	299
Average							69.15%
Criteria	Weight	Design					
		Glove					
		EB	PD	AD	WP	CR	AT
Performance	10	7	7	6	7	8	8
Ease of Attachment	8	9	8	8	8	7	7
Safety	7	7	9	9	8	9	7
Durability	6	7	6	7	6	7	7
Manufacturability	6	8	7	8	8	7	7
Cost	4	8	8	8	9	8	8
Total		313	307	309	310	315	301
Average							75.41%
Criteria	Weight	Design					
		Loop and Plate					
		EB	PD	AD	WP	CR	AT
Performance	10	10	9	10	9	9	8
Ease of Attachment	8	9	8	8	8	8	7
Safety	7	7	9	9	8	9	6
Durability	6	9	9	8	8	8	8
Manufacturability	6	8	8	6	7	8	6
Cost	4	8	8	7	8	8	7
Total		355	351	339	332	345	290
Average							81.79%
Criteria	Weight	Design					
		Vacuum Concept					
		EB	PD	AD	WP	CR	AT
Performance	10	7	7	7	8	8	8
Ease of Attachment	8	5	6	5	5	6	4
Safety	7	5	5	8	6	7	7
Durability	6	4	6	7	6	5	7
Manufacturability	6	6	5	7	5	5	5
Cost	4	4	8	6	7	6	5
Total		221	251	274	256	261	253
Average							61.63%

Figure 15: Data from weighted design matrix.

3.7 Manufacturing of Designs

3.7.1 Flipper Blades

The previous team of students from Worcester Polytechnic Institute that worked with Lola manufactured and tested flipper blades. Our group has adopted the design and thrust

characteristics from the past group. Our team manufactured the flipper blades by using Smooth-Sil 945 and 950. We created four total flippers, two of each type of material. We used Mold Star 15 to create a negative of the 3D printed flipper blade that was acquired from the previous year's MQP team (Figure 16). We did this by placing the plastic flipper into a plastic tub and pouring the liquid mixture around it. We let it cure for approximately four hours, removed the mold from the plastic tub and then removed the flipper from the mold. Once this negative mold of the flipper was created, we mixed the Smooth-Sil 945, poured it into this negative mold, and then let it cure for the recommended time of six hours. We then repeated this process, creating another flipper blade made of Smooth-Sil 945 and two additional blades made of Smooth-Sil 950 (Figure 17).



Figure 16: Negative mold of the 3D printed flipper blade.



Figure 17: 3D printed flipper blade; Smooth-Sil 945 flipper blade; Smooth-Sil 950 flipper blade.

3.7.2 Glove Design

To manufacture this design, we solicited help from Hanger Prosthetics in Worcester, MA. A prosthetist demonstrated the different sleeves and locking mechanisms that are used in human prosthetics. From Hanger Prosthetics we received two different sleeves to be used on the residual limb. One of the received sleeves is made of silicon and is used in combination with the Loop and Plate Design. The other sleeve is a combination of rubber and waterproof fabric as well as a male end of a locking system incorporated into the end of the sleeve. We also received two shuttle locks from Hanger Prosthetics that we used in our final design. These shuttle locks act as the female end of the locking system, which connect, to the male end of rubber sleeve. The shuttle locks and the rubber sleeves were used in the Glove Design.



Figure 18: The 3D printed piece used to create the mold for the final design.

To create a custom fit glove, we adopted the following procedure:

- We 3D printed the hollow glove shape that we designed in Solidworks (Figure 18). This shape was specifically designed to accurately depict the outer walls of our custom fit glove.
- We created a negative mold of the 3D printed shape using Mold Star 15.
- The molded residual limb was placed inside the rubber sleeve.
- The sleeve was attached to the shuttle lock and wrapped in plastic and duct tape to prevent it from getting stuck within the mold.
- A piece of PVC piping was placed over the shuttle lock's release button to maintain its functionality after the mold was poured.
- We placed a 3D printed flipper blade cap into the bottom of the mold to simulate the actual flipper blade and create a space to firmly place the molded flipper blades after the molded glove was completed (Figure 19).
- We placed the entire residual limb, rubber sleeve, and shuttle lock system into the negative mold created by the 3D printed hollow glove shape.
- We poured the mixed Smooth Cast 325 into the mold.
- Once the cast fully cured, it was removed from the mold.

When we removed the glove from the mold, we noticed areas where the pour did not settle evenly. Some of the areas were very thin which compromised the strength and durability of the glove. Our group poured additional material onto the thin spots to increase the strength. Then, we filed and sanded the abrasive spots on the glove to ensure the swimming dynamics were not compromised and that there were no sharp parts of the glove, which could cause harm to the turtle and/or environment. We also cut a hole for the shuttle lock's release button so it could be accessed. The last step was to attach the flipper to the custom glove. To better secure the flipper in place, we riveted the flipper to the glove and poured additional Smooth-Sil material in the space between the flipper and glove. The final Glove Design is shown in Figure 20.

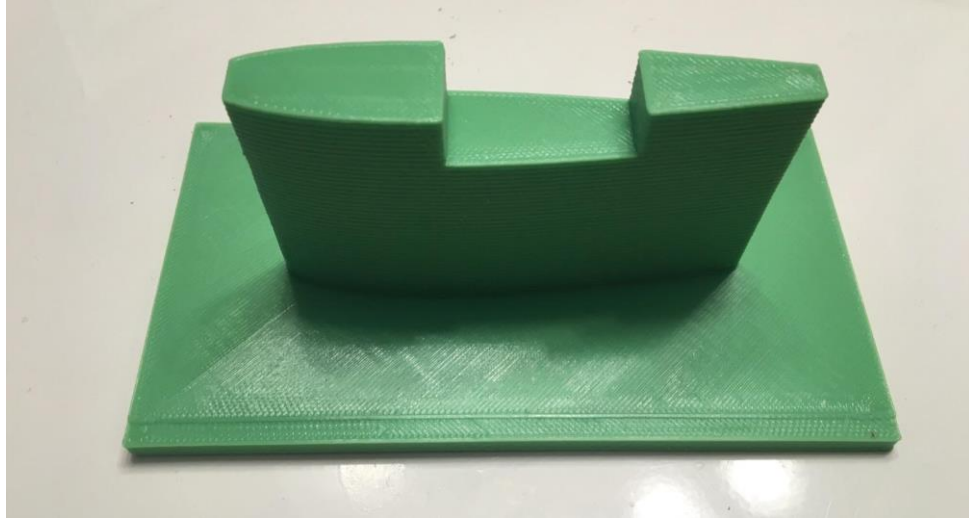

Figure 19: 3D printed cap of the Flipper Blade.



Figure 20: Final two glove designs and the sleeve.

3.7.3 Loop and Plate Design

To manufacture the Loop and Plate Design, we designed a part in Solidworks that consisted of a flat plate with slits, connected to a hollow elliptical shape, which would accept the flipper blade. This part was 3D printed with an XYZ DaVinci 1.0 printer to be nearly solid using ABS plastic (Figure 21).



Figure 21: 3D Printed Loop and Plate part.

We then cut an off-the-shelf Velcro strap to size and sewed neoprene material to the underside of the strap to create additional friction between the Velcro strap and the silicone sleeve provided by Hanger Prosthetics. We fed this custom strap through the slits within the 3D printed part. Finally, the flipper blade was riveted to the 3D printed part and additional Smooth-Sil material was inserted into the slot that the flipper slid into to better secure the flipper into place. The completed design can be seen in Figure 22.

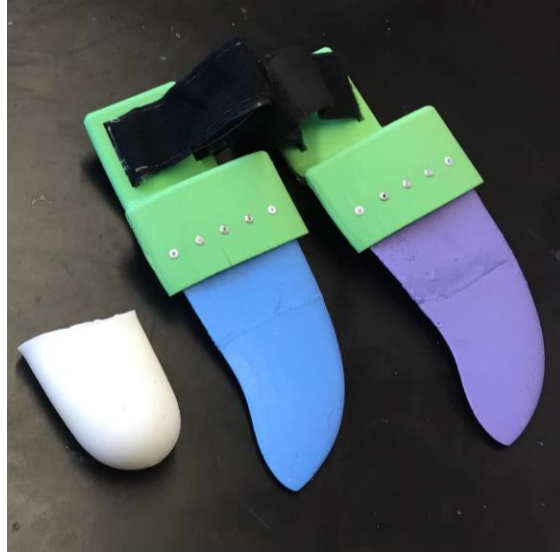

Figure 22: Completed Loop and Plate Designs.

3.8 Testing

3.8.1 Deflection Testing

We tested the flexibility of the two flipper blades and compared it to the flexibility of the flipper that the Key West Aquarium is currently using. We created a simple deflection test that the Aquarium could replicate for a direct comparison. We anchored the flippers horizontally at their bases and suspended them over the side of a table without applying any additional force to the flipper. We then measured the deflection that was created by their own weight at the tip of the blades. The Smooth-Sil 950 and 945 flipper blades deflected 1.5 inches (Figure 23) and 1 inch (Figure 24) respectively. The aquarium was able to perform the same test with the flipper that is in current use. This flipper deflected 1 inch (Figure 25).



Figure 23: Flipper made of Smooth-Sil 950 deflecting 1.5 inches.

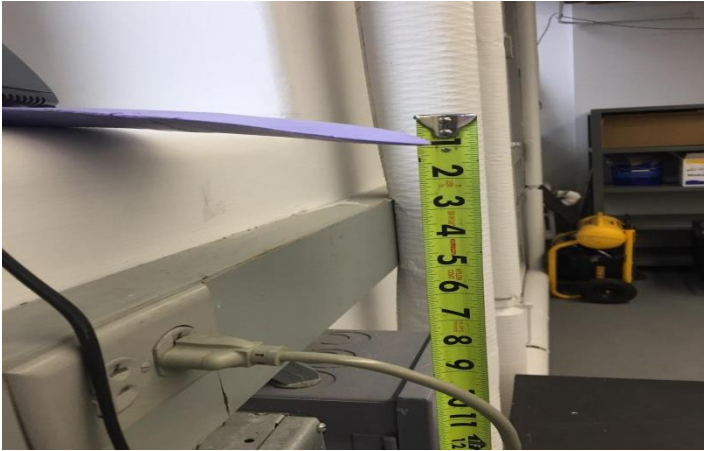

Figure 24: Flipper made of Smooth-Sil 945 deflecting 1 inch.



Figure 25: Flipper currently being used at the aquarium deflecting 1 inch.

3.8.2 Pressure Testing

To determine that our designs would not injure the turtle through the compressive stress applied on the stump, we completed a pressure test on the stump. We completed pressure testing by using Flex Force gauges (Figure 27) to calculate the force produced by the attachment piece on the residual limb. To calibrate the force gauges we used a weight set to achieve a baseline resistance at different weight intervals as outlined in Figure 26. Then using the results we were able to calculate a function that represented the equivalent force the stump encountered during the loading cycles. Then using the area of the sensor we can then calculate the pressure produced by the attachment on to the residual limb. The chart below is our calibration test for the force gauge.

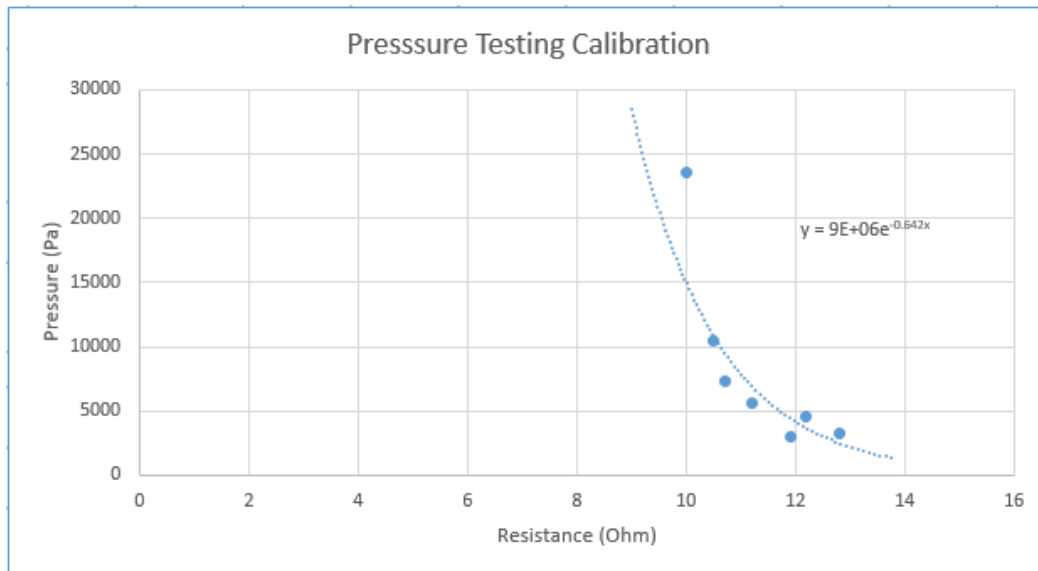

Figure 26: Calibration Testing Results.



Figure 27: Setup for pressure testing.

We placed the force gauge in two different locations on the stump for the first two designs, at the top and at the bottom and tested three different loading scenarios. In the third and final design in addition to the two other locations we also tested on the end of the stump. The three test points are shown in Figure 28.

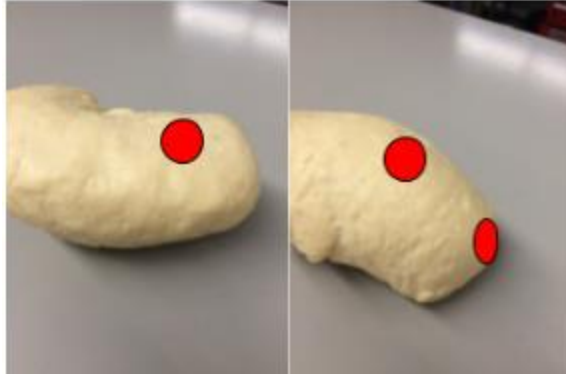

Figure 28: Location of the sensors on the stump.

The first loading scenario involved the process of attaching the prosthetic to the limb, and the second scenario involved testing the equivalent of the turtle taking a powerstroke with the flipper. We also recorded the pressure while at rest to simulate if Lola had the prosthetic attached while not using the fin to swim. To simulate the force generated by the powerstroke, we applied a 1.5 kg force at the end of the attachment piece, which was larger than the actual thrust force at the end of the residual limb [21]. We also ran the same test on a separate force gauge, to confirm the results we received in the previous test. The first gauge was a FlexiForce with a max force of 11.3 kg, and the second gauge was a FlexiForce with a range from .1kg to 10kg (Figure 29). Measurements from the two sensors were within 5% of each other.

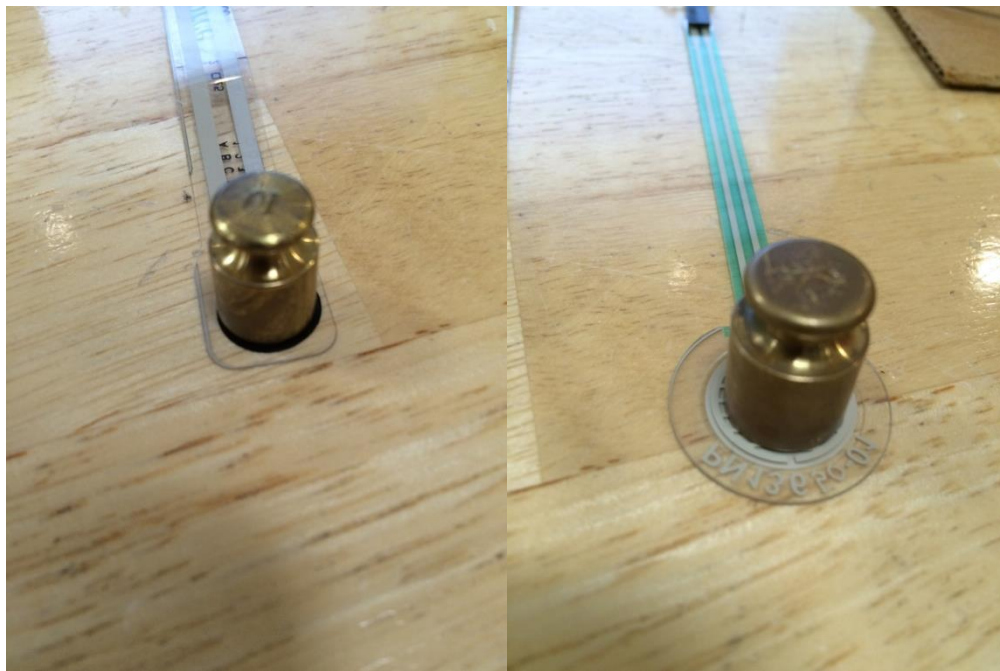

Figure 29: Two different sensors we used to assure the results were reasonable.



Figure 30: Pressure testing of Loop and Plate Design.

When we tested the Loop and Plate design in the water, a team member's closed hand was used in place of the mold of the turtle's residual limb to simulate the limb in the attachment. To test this design, we placed a sensor on the top of the stump where it is contact with the strap and on the bottom of the stump, near the end of the limb (Figure 31). After we converted the resistance to pressure, the highest pressure value we recorded for the loop and plate design was 4,700 Pa. When we tested the pressure levels in the glove design we placed the sensor on top of the stump and on the bottom and near the end of the residual limb. We calculated the maximum pressure for the glove design to be 20,300 Pa from the area of the force gage. When a pressure of 20,300 Pa is applied to a human for five consecutive hours blisters and sores will begin to form [22]. We determined that this would not be an issue for Lola because the aquarium will not be applying the prosthesis for that length of time until her residual limb adjusts to the prosthesis.

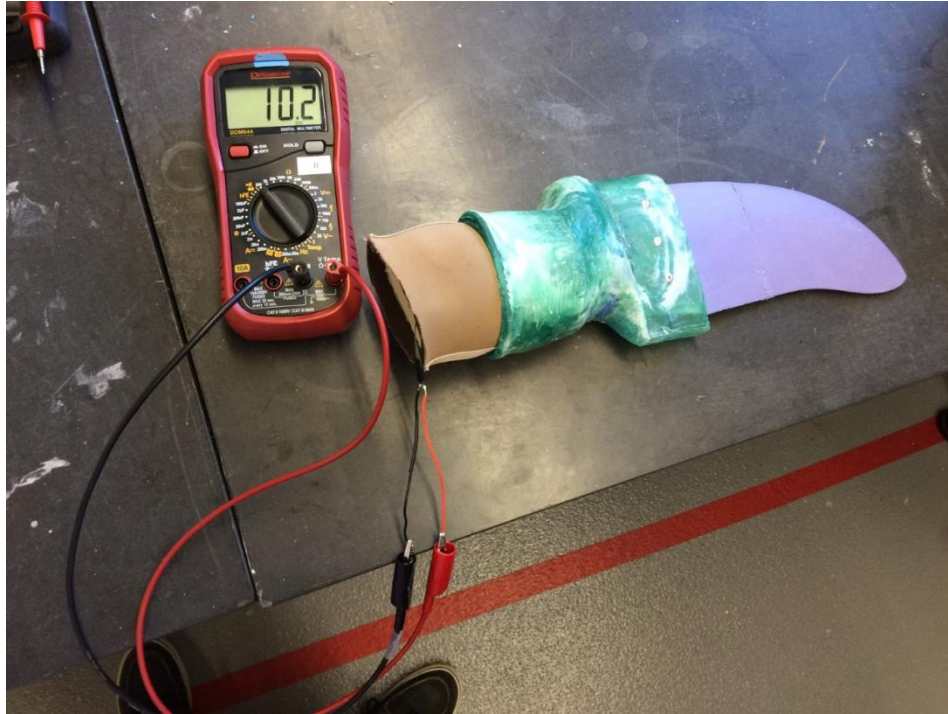

Figure 31: Setup for pressure testing on glove design.

When testing our final glove design we tested in three locations the top, bottom, and end of the residual stump. The resulting pressures from our final design can be seen in Table 2 below. We can see that our final design produced a lower amount of pressure from the previous glove design and the maximum recorded pressure being approximately 7260 Pa.

Table 2: Results from the pressure testing on the final Glove Design

Test Location	Physical Test	Resistance Produced (Ohm)	Equivalent Weight (g)	Force (N)	Area (m ²)	Pressure (Pa)
Top of Stump	Attachment Process	11.2	170	1.67	0.0003	5600
	Normal Load	N/A	0	0	0.0003	0
	Powerstroke	10.7	222	2.18	0.0003	7300
Bottom of Stump	Attachment Process	12.2	140	1.37	0.0003	4600
	Normal Load	N/A	0	0	0.0003	0
	Powerstroke	10.0	720	7.06	0.0003	24000
End of Stump	Attachment Process	12.8	100	0.98	0.0003	3300
	Normal Load	11.9	90	0.88	0.0003	2900
	Powerstroke	10.5	320	3.14	0.0003	11000

When looking into the pressure data, we can see that the loop and plate had the lowest pressure while the original design had the greatest. Our final design was between those values, only creating 7,260 Pa of pressure at a point, and this only occurred during the power stroke motion of swimming. To ensure that that the pressure is not high enough to cause ulcers, we compared this pressure to the pressure that is required to create ulcers in humans, due to the fact that there is little to no ulcer research on turtles. We found that in humans, complications from constant pressure starts to form at a magnitude of approximately 4,400 Pa, applied for a critical duration of time [23]. From that number, we conclude that the constant pressure produced by the prosthesis is in a healthy range for Lola, as the normal pressure is approximately 3,000 Pa. The powerstroke pressure is over this limit, however, this load would not be applied for a critical amount of time.

3.8.3 Water Testing

To determine whether or not these designs could perform as expected in real world situations, we conducted a performance test in the WPI pool. Kemp's Ridley sea turtles can generate a maximum flipper speed of approximately 50 cm/s (MQP number). To closely mimic real world scenarios, we replicated this maximum flipper speed in the water during testing. We tested two different scenarios or loading conditions for the attachment. The first scenario simulated the turtle swimming normally through the water. The second test determined the design's ability to stay attached to the team member's hand during an increased load. This test simulated the turtle thrashing with the prosthesis on.

During each loading scenario for the two designs, both attachments succeeded in remaining secure. There was no slippage or rotation of the attachment, even while testing thrashing conditions. This demonstrated that both attachments would adhere to the amputation site securely during both normal swimming and during aggressive thrashing. A photo of the testing is shown in Figure 32.

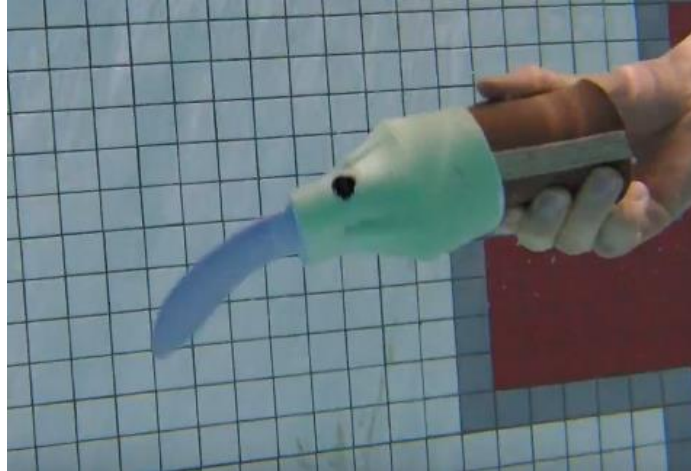

Figure 32: Water testing of the final Glove Design.

3.9 Final Design

3.9.1 Grommet Lock Design

The two goals that we wanted to accomplish with the improved glove design were to make it shorter and lighter because of the recommendations we received from the Aquarium. The Aquarium suggested shortening the design of the prosthesis because its length did not properly match the length of Lola's intact pectoral flipper, and she was able to bite on the tip of the flipper blade. Additionally, they noticed that Lola was having some difficulty maneuvering the device due to its weight. To accomplish our new design goals, we planned to use a smaller lock, redesign the mold for the glove and use a different material. Our first step in finding a smaller lock was to reach out to our contact at Hanger Prosthetics in Worcester, MA. We described the issues that we were having and they referred us directly to Coyote Design, which manufactures prosthetic locks. After speaking with representatives from Coyote Design, we ultimately decided to move forward with their grommet lock. The grommet lock, seen in Figure 33, is similar to the original shuttle lock in terms of meeting our specifications, but the advantage of the grommet lock is that it is much smaller in size.



CD104TM | Grommet Lock PED
10mm Pin

Weight w/Connector: 24 grams

Dimension: 1" Diameter

Weight Limit: 100 lbs

Build Height: Max of 1 3/8"

Amputation Type: BK, UE

Activity Level: Any

Figure 33: Grommet Lock From Coyote Design.

With the new lock for our design, several design modifications were needed. The first adjustment shortened the flipper blade itself by 3.7 inches. This correction created a proper stump to tip of flipper length of 6.3 inches. The next adjustment involved shifting the grommet lock's alignment off-center from the center of the flipper. In the previous design, with the center alignment of the shuttle lock, the pushpin release was flush with the edge of the flipper. However, since the grommet lock's radius is smaller than that of the shuttle lock, the lock's position was moved off the center of the flipper in order to maintain the flush alignment between the pushpin release and the edge of the flipper. Making the pushpin flush with the edge of the flipper ensures that it can be pushed easily for release. To make the prosthesis' design more compact, the lock was designed to overlap with a portion of the flipper blade. The portion of the flipper that overlapped with the lock had to be cut 2.4 inches. This cut allowed the maximum surface area of flipper blade in the prosthesis in order to ensure the flipper was securely attached to the glove. The adjustments made to the original design are outlined below in Figures 34 and 35.

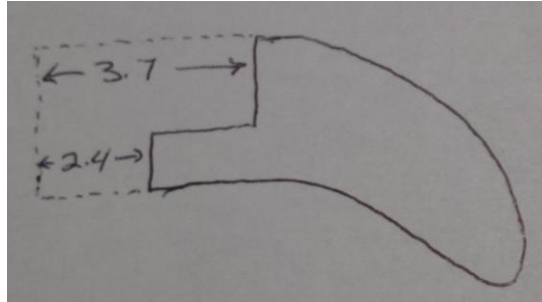

Figure 34: Flipper Blade Adjustments.

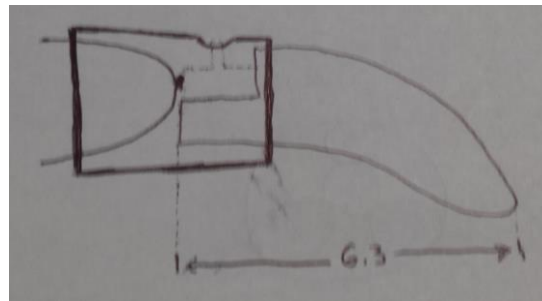

Figure 35: Lock Position Adjustments.

Given these modifications, the 3D CAD model was created using the same technique as the previous model. The dimensions of the flipper blade, grommet lock, and stump were used in the development of the 3D CAD model. This model was designed to have smaller dimensions than the model used previously in order to save weight. Below in Figure 36 is a screenshot of the SolidWorks model of the mold for the attachment.

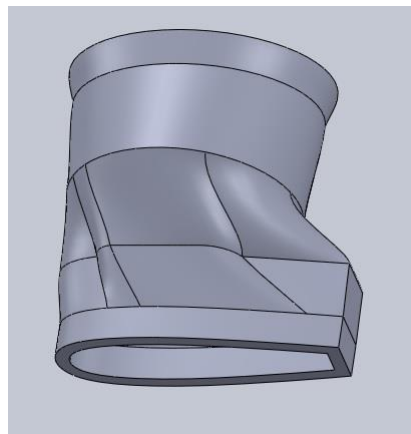

Figure 36: Screenshot of CAD model for new design.

Our last adjustment to make the prosthetic significantly lighter was to find a different material to make the cast with. On the original glove design, we used Smooth Cast 325 which worked very well in creating a hard cast that would not be damaged, however its weight made it useless once we sent it to the aquarium. To lighten the cast, we decided to use a material called Feather Lite. The Feather Lite material is very similar to the Smooth Cast 325 material in terms of durability, ease of use and strength. One common use for this material is in fishing lures, which are used in the same environment that Lola lives in. The Feather Lite material had a significantly lower density as compared to the Smooth Cast 325, which contributed largely to decrease the weight of the final product. The first complete prototype with the flipper and [Smooth Cast 325] glove weighed 640 grams. The complete final product with the flipper and [Feather Lite] cast weighed 305 grams.

3.9.2 Manufacturing of Grommet Lock

The manufacturing process of this design was very similar to the process we performed on the first glove design. We used the 3D printed hollow glove shape to create a mold using the same Mold Star 15. Once the mold was fully cured we took the mold of Lola's residual limb, placed it in the sleeve and attached it to the new Grommet Lock with a small piece of $\frac{3}{4}$ " PVC pipe over the release to prevent the material from forming around the release making it impossible to press. We also wrapped the lock and sleeve in saran wrap to keep the Feather Lite from leaking inside the lock making it unable to release once it hardens. Feather Lite material is much less dense and takes much longer to cure than the previously used Smooth Cast 325 material. This resulted in much of the material leaking into the Grommet Lock, and we could not release the mechanism from the stump. We then were forced to break apart the prosthetic to try and fix the Grommet Lock to hopefully reuse it in a new design, unfortunately we were unable to remove the material from the Grommet Lock and the pin was unable to be removed. In our second attempt, we replicated the same manufacturing techniques, but this time we utilized additional wrap and duct tape to prevent leaking. This worked perfectly and we were able to remove the sleeve and mold of Lola's residual limb by using the release on the Grommet Lock. Then to attach the flipper to the prosthesis we cut the flipper much shorter to fix the original issue of the design being too long, and also cut the flipper to fit inside the bottom of the cast as tight as possible. We then poured Smooth-Sil 945, which is the same material as the flipper, to act as an adhesive to create a tight fit for the flipper.

4. Field Testing

Once the first generation Loop and Plate and Shuttle Lock designs, as well as the final Grommet Lock design, were manufactured and tested, they were shipped to the Key West Aquarium to be used on Lola in field-testing. The Aquarium's employees handled all three prostheses and Lola was given an opportunity to swim and test the three devices.

4.1 Loop and Plate Design

The main complaint with both of the manufactured prostheses was their overall length. Compared to the original prosthesis manufactured by previous WPI students, the Loop and Plate design measured an additional 2.5 inches. Because of this extra length, Lola was able to bite the prosthetic flipper and cause it damage. Additionally, this prosthesis was a bit heavier than Lola's previously manufactured flipper, weighing 399 grams compared to 286 grams. The Aquarium also expressed some concerns on the ease of attachment and the secureness of the prosthesis. Lola's handlers had difficulties attaching the device to her residual limb, and because it was not always attached correctly, it often came loose while Lola was swimming.

4.2 Shuttle Lock Design

Similarly to the Loop and Plate Design, the additional length of the Shuttle Lock prosthesis was a cause of concern. This device measured ten inches, compared to the six inches of the previously manufactured prosthesis (Figure 37). Another complication of this design was its weight of 655 grams, compared to the previous 286 grams. The Aquarium employees noticed that Lola was having trouble maneuvering the flipper through the water due to its weight, which made it more of a hindrance for her than an advantage. However, overall, Lola's handlers had very positive reactions to the device; they stated that the prosthesis was easy to use and the application time of the device was timed at 2-3 minutes, compared to the 10-minute attachment time of Lola's previous flipper.



Figure 37: (T-B) Loop and Plate Design, Shuttle Lock Design, and Previous Design Prostheses Lengths.

After field testing data was collected and assessed on the first generation Loop and Plate and Shuttle Lock designs, the team and the Aquarium decided it would be most beneficial to move forward with a second generation of the Shuttle Lock device and to eliminate the Loop and Plate device due to inadequate performance.

4.3 Grommet Lock

The team manufactured the Grommet Lock prosthesis to address the feedback provided by the Key West Aquarium and shipped the device to be used in field testing. Because a new, lightweight material was used in the design, the total device weight was 305 grams, 19 grams heavier than Lola's previous prosthesis. This additional weight did not have an effect on Lola's swimming abilities, as she was able to maneuver through the water with ease. Additionally, the device was properly sized at six inches in length, making it impossible for Lola to bite the flipper blade to damage it. According to the Aquarium, the biggest attribute to this design was its ease in attachment. Similarly to the Shuttle Lock device, the attachment time of this prosthesis was timed at 2-3 minutes, thus decreasing the attachment time fivefold. The Grommet Lock prosthesis also remained securely attached to Lola's stump as she swam through the water. It maintained a proper orientation and did not spin about her residual limb.

The Aquarium did note that there were some minor modifications that they would make to the device in the future. The caudal edge of the device was rubbing against the back aspect of

Lola's elbow, creating a blister. To remedy this, they removed a one cm semicircle at the caudal edge, which proved to be successful. Also, they expressed an interest in developing a prosthesis in a more natural coloration. But, they also noted that Lola and the other aquatic animals in her tank did not seem to mind the unnatural color scheme. Overall, the reaction to the Grommet Lock prosthesis was very favorable, both by Lola and her handlers. The prosthesis met our desired goals in performance, ease of attachment, environmental safety, and durability, with an expected lifespan of two years. The Key West Aquarium has already expressed interest in applying the technology used in the Grommet Lock prosthesis to other sea turtles with similar injuries, demonstrating the design's definitive success.

5. Final Design Validation

Section 5.1 outlines the basic manufacturability of the final design, while Section 5.2 details the sustainability of the prosthesis. In Section 5.3, the ethical concerns of the device are discussed, and Section 5.4 references the health and safety issues that were considered. Section 5.5 hits on the economic impact of the final design, Section 5.6 does the same with the environmental impact, and Section 5.7 goes into the societal impact. Political ramifications are considered in Section 5.8, while section 5.9 delves into the knowledge of contemporary issues.

5.1 Manufacturability

The final design is intended to be simple to manufacture for any turtle based off the process used for Lola's model. The flipper blade would only need to be scaled in size with accordance to the size of the turtle the prosthesis was being created for. When creating the attachment piece of the device, a cast of the residual limb would need to be made, so that the critical points could be measured, and these measurements could be applied to the SolidWorks file.

5.2 Sustainability

This device is completely passive, in that it requires no external energy in order to operate it, only needing the turtle's muscle movement to perform. Many of the materials used in the device are durable and are expected to last for multiple years when being used by a turtle in captivity. The process of manufacturing the device has many components that could be reused to make more devices for other turtles.

5.3 Ethical Concerns

As this device is only intended to improve both the quality of life of amputee sea turtles and the usability for those applying it, there should be no ethical concerns for its existence. If the device were to evolve and other factors would be applied to its creation, then this may need to be reconsidered.

5.4 Health and Safety Issues

The device is currently completely safe for a turtle to use and use with any other turtles around it. No sharp edges, hazardous materials, or dangerous methods were used in its manufacturing. If the device were to fail, it would be in a way that would not be hazardous to any of the turtles, and it would be easy to identify the oncoming failure of the device through gradual wear and tear.

5.5 Economics

This prosthesis was created to meet a need for amputee turtles, not to fit a need for a market. The device is not being patented, and the manufacturing process is being thoroughly documented in this report so that others could recreate this design to help more turtles. It is constructed of affordable materials and simple manufacturing methods so that the creation of the prosthesis is very accessible.

5.6 Environmental Impact

The device is comprised entirely of moldable silicones and plastics, along with a sleeve and lock mechanism that's commonly used in human prosthetics today. The materials are all nondegradable, nonhazardous, and waterproof, so that the device should have no impact on Lola's confined environment, or the environment as a whole. The manufacturing process itself also had no impact on the environment, as proper use and disposal of all materials was followed.

5.7 Societal Impact

This device is being publicly acknowledged by staff members at the Key West Aquarium in Florida when it's in use by Lola. It's also being publically referenced by many forms of media. All of this will hopefully drum up some a greater awareness that sea turtles are endangered and need the help of humans to survive. Also, publicity for this device can hopefully reach other individuals in possession of amputee sea turtles, who can then follow the manufacturing guidelines detailed in this report to create their own prostheses to help more turtles.

5.8 Political Ramifications

This device is free to be replicated and used by any individual to help an animal in need, and therefore should have no impact on the political landscape.

5.9 Knowledge of Contemporary Issues

The main contemporary issue this project is involved in is the endangerment of animals in general. It varies from animal to animal how thoroughly the specie's state is publically referenced, and because sea turtles are not highly defended by the public today, this device is meant to greatly improve their chance for survival. As this device is only intended to have positive ramifications, it properly aids in the attempt for a solution to the contemporary issue.

6. Conclusion

The goal of this project was to create a sea turtle prosthesis that adheres to the residual limb securely, easily, and efficiently in order to achieve proper biomimetic locomotion. Our strategy for achieving biomimetic locomotion was to create a prosthesis that maintained a natural range of motion and consistent, proper alignment. These qualities, combined with minimizing the prosthesis' weight, application time, and difficulty, were all factors that contributed to the design process of our prosthesis.

The critical component of our securement method was a grommet lock from Coyote Design. The grommet lock was the best fitting solution because in addition to being water resistant, it was the smallest and lightest (24 grams) available push pin release lock that could handle the adequate force loads. The past design often fell off because its securement method was too weak. With the addition of the grommet lock and a tacky prosthetic sleeve, the securement of the new prosthesis on Lola's residual limb was sound and much stronger than the prosthesis manufactured by the previous WPI students.

The flipper blade created proper alignment every time the prosthesis was attached to the stump. The glove portion of the prosthesis was custom-made to fit Lola's residual limb. The customization of the glove provided only one possible orientation for the prosthesis to attach to Lola's stump, creating a consistent flipper-blade alignment while also giving Lola a comfortable fitting device. In addition, the previous year's design incorporated many different Velcro straps to secure the flipper to the amputation site. This made the attachment process long and tedious. Because of the simplicity of our new prosthesis, the attachment time was decreased fivefold, making the process less stressful for both Lola and her handlers. Our prosthesis also helped Lola achieve biomimetic motion on her amputated limb. The created device matched the size of her healthy flipper, allowing for balanced movement. With the help of the new prosthesis, she could properly complete a full power stroke. Our final prosthesis attachment weight was very similar to that of the original prosthesis. After incorporating featherlight material into our final design, the total weight was 305 grams. That is less than a 7% increase in weight from the original design for a large increase in usability of the attachment.

Overall, the created prosthesis was deemed a success. Only minor alterations were made to the design to make it more suitable to Lola. With additional minute adjustments, other sea turtles around the world with flipper amputations could use the grommet lock design. This could, in turn, decrease the amount of euthanized turtles, allow amputee turtles to mate, and turn the tide of sea turtle extinction.

7. Recommendations

Our project focused on improving the usability of a prosthetic turtle flipper by reducing the time of attachment, increasing the consistency of the alignment, and modifying the design to make it easy to recreate for other turtles. As it currently stands, this device sets a strong starting point for a prosthesis that can be widely reproduced to help more turtles. Basic metric goals and evaluations were used to assess the success of the device that was created, but more long term field studies could be conducted to further improve the design.

One aspect of the design that has been brought to our attention after immediate field-testing is the collar rubbing against Lola's elbow and creating a blister. Staff members of the aquarium have since cut a semicircle around the elbow and reported that to solve the problem. It is for that reason that a simple alteration to the design, which angles the collar of the device down and away from the elbow, should serve as an apt solution.

Going beyond single pectoral amputee turtles, many turtles lose multiple flippers, mainly in predator attacks. Because of this, the concept of a single flipper prosthesis would need to be expanded to accommodate such injuries. Initial thoughts are to secure multiple prostheses on a single turtle through the use of a vest that would hold everything in place. This would be necessary because more missing limbs would lead to greater instability in the turtle's movement, so the vest prosthesis would be needed to prevent any of the devices from falling off.

A more long-term form of field-tests would benefit the progress of the device by revealing issues that could not be predicted in the in-lab design process. A clear example of this is the collar of the device leading to blisters on the turtle's elbow. There was no way to predict this issue in-lab, as the model of Lola's stump was only from above her elbow, but it was quickly discovered once she started using the device. Another long-term concern that does not directly relate to the turtle is how the device itself degrades with use. Constant stress and fatigue from being attached to a turtle on a daily basis could uncover mechanical weaknesses that in-house pressure and pool testing did not, which could lead to later revisions of the device.

Any worker at any aquarium with basic design software exposure could create this current device, but some potential alterations would require a greater level of manufacturing ability. Such changes could include more points of mobility in the flipper, or better accounting for rotation in the power stroke motion that has been lost. Location sensors that could measure force and velocity would be necessary to determine the difference in motion between the healthy and prosthetic flippers, and from there, proper design alterations could be made to address these differences. With minor alterations, this design could have a mass appeal to sea turtles across the world afflicted with flipper amputations, thus reducing the rate of sea turtle euthanasia.

References

- [1] Defenders of Wildlife. (2016). Basic Facts About Sea Turtles. Retrieved October 07, 2016, <http://www.defenders.org/sea-turtles/basic-facts>
- [2] Endangered Species Act (7 U.S.C. § 136, 16 U.S.C. § 1531 et seq.)
- [3] Sea Turtle Conservancy. (2015). Sea Turtles: Why Care? Retrieved October 07, 2016, <http://www.conserveturtles.org/seaturtleinformation.php?page=whycareaboutseaturtles>
- [4] Hannan, L.B., Roth, J.D., Ehrhart, L.M., Weishampel, J.F. (2007). Dune vegetation fertilization by nesting sea turtles. *Ecology* 88(4): 1053-1058.
- [5] Feild, Reshad Field. (2002). *The Last Barrier: A Journey into the Essence of Sufi Teachings*, Publisher: Lindisfarne Books, ISBN 1584200073.
- [6] C. Benjamin MA, Medline Plus. (2014). Leg or Foot Amputation, Retrieved October 07, 2016, <https://medlineplus.gov/ency/article/007365.htm>
- [7] Seaturtle-World. (2014). Sea Turtles in Captivity. Retrieved October 07, 2016, <http://www.seaturtle-world.com/sea-turtles-in-captivity/>
- [8] <http://www.seaturtleinc.org>
- [9] Wyneken, J. (1997). Sea turtle locomotion: mechanisms, behavior, and energetics. *The biology of sea turtles* Vol. 1. CRC Press.
- [10] <http://www.newworldencyclopedia.org/entry/Turtle>
- [11] <http://www.sportsmd.com/performance/muscle-imbalance-common-overuse-injuries/>.
- [12] Wyneken, J., & Witherington, D. (2001). *The anatomy of sea turtles* (p. 172). National Marine Fisheries Service.
- [13] Davenport, J., Munks, S. A., & Oxford, P. J. (1984). A comparison of the swimming of marine and freshwater turtles. *Proceedings of the Royal Society of London B: Biological Sciences*, 220(1221), 447-475.
- [14] How liners work. (2016). Retrieved October 07, 2016, from <http://www.ottobockus.com/Prosthetics/info-for-new-amputees/prosthetics-101/how-liners-work/>
- [15] WintersGel Prosthetic Liners. (2015). Retrieved October 07, 2016, from <http://www.hangerclinic.com/limb-loss/adult-lower-extremity/adv-tech/Pages/WintersGel-Prosthetic-Liners.aspx>
- [16] Pursley, R. J. (1955). Harness patterns for upper-extremity prostheses. *Artificial limbs*, 2(3), 26. <http://opmarketing.com/storage/Research%20Encyclopedia/Vacuum%20Assisted%20Suspension/Street-%20Vac%20Effect%20on%20RL.pdf>

- [17] LaBarre, S. (2010, June 23). Prosthetic Flipper Turns Amputees Into Mermen. Retrieved October 07, 2016, from <https://www.fastcompany.com/1662946/prosthetic-flipper-turns-amputees-mermen>
- [18] Krassenstein, B. (2014, October 31). Elle: The Incredible 3D Printed Swimming Leg for Amputees. Retrieved October 07, 2016, from <https://3dprint.com/22221/elle-swimming-prosthetic/>
- [19] [1] "Allison's Prosthesis." Allison's Prosthesis. Sea Turtle Inc., Retrieved from <http://www.seaturtleinc.org/rehabilitation/allison/>.
- [13] [2] Iacurci, Jenna. (2014, May 17). "Sea Turtle Amputee Swims Again with Jet-Like Prosthetic Fin." Nature World News. Retrieved from <http://www.natureworldnews.com/articles/7110/20140517/sea-turtle-amputee-swimsagain-with-jet-like-prosthetic-fin.htm>.
- [14][3] Wang, Yue. (2013). Disabled Sea Turtle Gets 27th Pair of Artificial Fins. Time. Retrieved from <http://newsfeed.time.com/2013/02/22/disabled-sea-turtle-gets-27th-pair-ofartificial-fins/>.
- [15][4]"Winter", Clearwater Marine Aquarium, 2016. [Online]. Available: <http://www.seewinter.com/winter>. [Accessed: 07- Oct- 2016].
- [21] Liang, V., Varela, S., and Wong, I. (2016). Design of a Prosthetic Flipper for a Kemp's Ridley Sea Turtle. Major Qualifying Project, Worcester Polytechnic Institute
- [22] Loerakker, S. (2007). Aetiology of pressure ulcers. *Eindhoven University of Technology, Dept. of Biomedical Engineering, Section Materials Technology, Div. Biomechanics and Tissue Engineering*.
- [23] Agrawal, K., & Chauhan, N. (2012). Pressure ulcers: Back to the basics. *Indian Journal of Plastic Surgery: Official Publication of the Association of Plastic Surgeons of India*, 45(2), 244–254. <http://doi.org/10.4103/0970-0358.101287>
- [24] Technical Communications Packages. (2016). Dassault Systemes. Retrieved from <https://www.solidworks.com/sw/products/technical-communication/packages.htm>.