

Pacific University

CommonKnowledge

---

College of Optometry

Theses, Dissertations and Capstone Projects

---

5-1999

## Oligon-coated contact lens case study: The efficacy of oligodynamic iontophoresis as a contact lens disinfection system as determined by FDA stand-alone protocol

Jennifer H. Dull  
*Pacific University*

John D. Hoven  
*Pacific University*

### Recommended Citation

Dull, Jennifer H. and Hoven, John D., "Oligon-coated contact lens case study: The efficacy of oligodynamic iontophoresis as a contact lens disinfection system as determined by FDA stand-alone protocol" (1999). *College of Optometry*. 1274.  
<https://commons.pacificu.edu/opt/1274>

This Thesis is brought to you for free and open access by the Theses, Dissertations and Capstone Projects at CommonKnowledge. It has been accepted for inclusion in College of Optometry by an authorized administrator of CommonKnowledge. For more information, please contact [CommonKnowledge@pacificu.edu](mailto:CommonKnowledge@pacificu.edu).

---

# Oligon-coated contact lens case study: The efficacy of oligodynamic iontophoresis as a contact lens disinfection system as determined by FDA stand-alone protocol

## Abstract

Prototype contact lens cases have been prepared which are coated with an Oligon antimicrobial silicone formulation. The Oligon silicone coating incorporates a conductive additive, silver and platinum powder to set up an electrochemical system, that when contacted by chloride ions found in physiological saline, releases silver ions into the surrounding aqueous medium. Silver ions have been reported in the literature to be a potent antimicrobial agent, showing effectiveness against both gram-positive and gram-negative bacteria as well as yeasts and molds. This study was designed to study the effectiveness of Oligon coated contact lens cases against FDA (Food and Drug Administration) approved Stand Alone protocol for disinfecting contact lenses for the following organisms: *Pseudomonas aeruginosa*, *Serratia marcescens*, *Staphylococcus aureus*, *Candida albicans*, and *Fusarium solani*. The results of the study conclude that the Oligon cases do not meet the 8 hour FDA stand alone criteria for any of the organisms tested, but with modification, may be an exciting new frontier for the future of contact lens disinfection.

## Degree Type

Thesis

## Degree Name

Master of Science in Vision Science

## Committee Chair

Patrick J. Caroline

## Subject Categories

Optometry

## Copyright and terms of use

If you have downloaded this document directly from the web or from CommonKnowledge, see the "Rights" section on the previous page for the terms of use.

**If you have received this document through an interlibrary loan/document delivery service, the following terms of use apply:**

Copyright in this work is held by the author(s). You may download or print any portion of this document for personal use only, or for any use that is allowed by fair use (Title 17, §107 U.S.C.). Except for personal or fair use, you or your borrowing library may not reproduce, remix, republish, post, transmit, or distribute this document, or any portion thereof, without the permission of the copyright owner. [Note: If this document is licensed under a Creative Commons license (see "Rights" on the previous page) which allows broader usage rights, your use is governed by the terms of that license.]

Inquiries regarding further use of these materials should be addressed to: CommonKnowledge Rights, Pacific University Library, 2043 College Way, Forest Grove, OR 97116, (503) 352-7209. Email inquiries may be directed to: [copyright@pacificu.edu](mailto:copyright@pacificu.edu)

**OLIGON-COATED CONTACT LENS**  
**CASE STUDY:**

***THE EFFICACY OF OLIGODYNAMIC  
IONTOPHORESIS AS A  
CONTACT LENS DISINFECTION SYSTEM AS  
DETERMINED BY  
FDA STAND-ALONE PROTOCOL***

**BY**

**JENNIFER H. DULL  
JOHN D. HOVEN**

**A Thesis submitted to the faculty of the  
College of Optometry  
Pacific University  
Forest Grove, Oregon  
For the degree of  
Doctor of Optometry  
May, 1999**

PACIFIC UNIVERSITY LIBRARY  
FOREST GROVE, OREGON

**Advisors:  
Patrick J. Caroline  
Diane Yolton, PhD, OD**



## About the Authors

Jennifer H. Dull- Jennifer grew up in Lewistown, Montana where she was active in athletics and academics. She attended Carroll College in Helena, Montana and received her Bachelor's degree from Pacific University in Visual Science. Jennifer hopes to join a practice in Wisconsin where her husband is a surgical resident.

John D. Hoven- John is a native of Alexandria, Minnesota. He attended Hamline University where, in 1993, he received a Bachelor of Arts degree in Biology and English. He moved to Montana after graduating college to work in the optical industry before attending Pacific University. Upon graduation, John will return back to his hometown to practice optometry in a private practice.

Abstract:

Prototype contact lens cases have been prepared which are coated with an Oligon antimicrobial silicone formulation. The Oligon silicone coating incorporates a conductive additive, silver and platinum powder to set up an electrochemical system, that when contacted by chloride ions found in physiological saline, releases silver ions into the surrounding aqueous medium. Silver ions have been reported in the literature to be a potent antimicrobial agent, showing effectiveness against both gram-positive and gram-negative bacteria as well as yeasts and molds. This study was designed to study the effectiveness of Oligon coated contact lens cases against FDA (Food and Drug Administration) approved Stand Alone protocol for disinfecting contact lenses for the following organisms: *Pseudomonas aeruginosa*, *Serratia marcescens*, *Staphylococcus aureus*, *Candida albicans*, and *Fusarium solani*. The results of the study conclude that the Oligon cases do not meet the 8 hour FDA stand alone criteria for any of the organisms tested, but with modification, may be an exciting new frontier for the future of contact lens disinfection.

## Introduction:

The traditional contact lens care regimen, although functional, has problems with compliance, hypersensitivity reactions to preservatives in solutions, and the effectiveness of microbial reduction. These problems have resulted in infections of the eye. Thus, there is a need for a disinfection method that is easy to use, preservative free, and successful in reducing different kinds of organisms on both contact lenses and cases. Preliminary studies have been done on a prototype contact lens case and have suggested that this type of disinfection method can kill contaminating microorganisms and would be easy to use.

The prototype contact lens cases, developed by Oligon, have a silicone coating on the well surface that has platinum and silver ions impregnated in it. Upon contact with physiological saline, the silver ions are released into the aqueous medium by an electrochemical current initiated by the chloride ions in the saline. This process is known as oligodynamic iontophoresis. Free silver ions have been used through the ages and have been shown in the literature to be a powerful antimicrobial agent. Silver was first used in ancient Roman times as the lining for aqueducts, and is currently utilized as an antimicrobial agent in catheters. A number of patents are filed which are attempting to expand the medical uses of this technology, including implantable, bacteriocidal medical devices.

Preliminary studies have shown promise in the use of Oligon technology in contact lens care. The purpose of our study was to determine the effectiveness of the Oligon coated prototype cases using the FDA Stand Alone Protocol for contact lens disinfection. To meet the Stand Alone criteria, no other methods may be used to alter the lenses, including digital or mechanical rubbing, and there must be a kill rate of not less than 3 log units for the bacteria, and not less than 1 log unit for yeasts and molds, in an 8 hour time frame. The FDA dictates that the care system must be effective against the following organisms: Pseudomonas, Staphylococcus, Fusarium, Candida, and Serratia. (See Appendix for complete FDA Stand-Alone Procedures)

## Methods:

To test the Oligon disinfection lens cases, Implimed provided 10 coated Alcon standard lens cases (there are 2 contact lens wells per case.) In addition we acquired 10 other Alcon standard cases, brand new and with out modifications. Each contact lens well was treated as an individual test, with 8 wells (4 cases) for each organism, 2 coated cases and 2 non-coated controls.

Each well was inoculated with a microorganism and a 100 ul initial sample was taken. In order to gain countable plates 4, 1:10 dilutions were performed and individually plated on the appropriate agar. (See Appendix Media) This constituted time 0 (zero.) To adhere to a strict timing regimen, another well was inoculated at exactly 5 minutes after the first well, also indicating time 0 (zero) for that well. (See Appendix Timing.) The 5 minute delay was necessary to perform the dilutions and plating, and obtain the materials needed for the next test. At times 2, 4, 6, 8, and 32 hours, 100 ul samples were taken from the wells, and again, 4, 1:10 dilutions were performed and plated for each sample. Given the large quantity of agar plates, test tubes, pipettes, and space needed, we divided our experiment into 2 days. Staphylococcus and Pseudomonas were tested on the first day, Serratia, Candida and Fusarium, on the second. Plate counts were obtained for the bacterial plates at 48 hours and 72 hours for the yeasts and molds.

The following procedures will be discussed in detail: (A) preparation of media, (B) preparation of inocula, (C) inoculation of contact lens wells, (D) serial dilutions and plating, and (E) plate counts.

A. Preparation of Media- Agar plates (TSA, PDA, SDA) were prepared 2 days prior to the experiment and were made to incorporate a Diffco neutralizing buffer. The procedure is as follows:

- (a) Mix TSA, PDA, and SDA medium to include the Diffco neutralizing buffer at 5.2 gm/L.
- (b) Enough media is required for 200 plates per organism (8 wells, 4 control wells and 4 test wells, X 6 sample times, X 4 dilutions per sample = 192 plates.)
- (c) Media preparations are placed in 1000 ml Erlenmeyer flasks for ease in pouring, and autoclaved at pressure and temperature for 30 minutes.

- (d) From the autoclave, the flasks are transferred to a controlled temperature water bath and allowed to equalize at temperature, 46-47 C, for 1 hour prior to pouring.
- (e) Completed plates are marked and coded with a marking pen denoting organism, control or test group, well number and time, and refrigerated until 2 hours prior to use.

As a time saving procedure, test tubes containing sterile saline may also be made and pipetted prior to running the experiment. For samples taken every 5 minutes, 4 test tubes of sterile saline are required. The first dilution requires 100 ul of inocula to be added to **9.9 ml of sterile saline**. Then, 3 dilutions are performed, adding 1 ml of inocula to **9 ml of sterile saline**. Thus, to perform the whole experiment (8 test wells X 5 organisms X 6 sample times X 4 dilutions per sample), 960 test tubes of sterile saline are required, 240 test tubes with 9.9 ml of saline and 720 test tubes with 9.0 ml of saline. Properly labeling and storing the test tubes in racks, in groups of 4, will avoid confusion and increase the efficiency of the experiment.

B. Preparation of Inocula- ATCC organisms, shipped in glass vials, need to be rehydrated prior to use. Sterile, physiological saline is sufficient to suspend the mixture in the vial. This mixture is then transferred to the appropriate agar plate and allowed to incubate for the required time. (See Appendix Media) Given the longer incubating time for *Fusarium solani*, it is appropriate to start with that organism up to 14 days prior to use.

- (a) 8 agar plates per organism will be required for preparation of the inocula, 2 to plate the rehydrated ATCC mixture and 6 to provide isolated colonies.
- (b) After the required incubation time to grow the ATCC vial organisms, streak plates are prepared to provide isolated colonies. Streak a plate from the culture slant in quadrants, flaming the inoculating loop before each streak. Repeat this process to provide 6 plates total, and incubate. For the bacteria, this should be done 24-48 hours prior to starting the experiment.
- (c) The day of the experiment, isolated colonies are harvested with a sterile cotton swab moistened with sterile saline. Transfer the inoculated swab to a test tube containing sterile saline and vortex, allowing the swab to rotate freely.
- (d) Repeat this process until the media appears turbid and milky in appearance. This should represent approximately a

$10^7$  to  $10^9$  solution. If lab equipment allows, spectroscopy or a McFarland standard may be applied to verify bacterial concentration in solution. (See Appendix McFarland)

(e) To obtain spores from *Fusarium solani*, hyphae are harvested with a flamed loop and transferred to sterile saline. This mixture is vortexed and centrifuged. Both the supernate and substrate are then washed with more sterile saline and filtered through fine cheesecloth. Repeat the washing process 3 to 5 times to obtain inocula consisting of mostly spores.

(f) Vials of inocula are stored at 20-25 C prior to use, and protected from light and contaminants.

C. Inoculation of Contact Lens Wells- Prepared vials of inocula are stored at an approximately, or if known through prior testing,  $10^9$  concentration. FDA protocol dictates that test inocula be between  $10^5$  to  $10^6$  cfu/ml and that the volume of inocula not exceed 1% of the sample volume. (p 96 C1) The test volume of the contact lens is set at 2 ml, thus serial dilutions are required to set the test inocula in the wells to the required concentration and volume.

(a) Vials of inocula are vortexed to ensure all bacteria are in suspension. 1 ml of the approximate  $10^9$  inocula is pipetted into 9 ml of sterile saline and vortexed. This represents a 1/10 dilution and a final concentration of about  $10^8$ .

(b) Each contact lens well is to be swabbed with isopropyl alcohol prior to use. After swabbing, the cases are allowed to air dry under a sterile hood for 1 hour.

(c) Upon drying and at test time zero (0) (See Appendix Timing) for the lens well to be tested, 2 ml of sterile saline are pipetted into the appropriate contact lens test well. 20 ul of the  $10^8$  inocula is added to the lens well with a 10-100 ul Ependorf Research Pipette. This represents a 1/100 dilution leaving the initial test concentration in the well at about  $10^6$  cfu/ml.

(d) To insure dispersion of the inocula, cases are capped and gently agitated in a figure-8 pattern for 1 minute.

D. Serial Dilutions and Plating- At the instant the 20 ul inocula is transferred to the first test well, the timer is initiated. This is time zero and 5 minutes remain before the next test well is to be inoculated. (See Appendix Time) Quickness, speed and accuracy are necessary to maintain the strict time requirements of this experiment.



- (a) After the 1 minute of agitating the inoculated test well to ensure proper mixing, 100 ul are extracted from the lens well using the 10-100 ul Ependorf Scientific Research pipette and added to 9.9 ml of sterile saline. This mixture is vortexed and represents 1/100 dilution, and a concentration of  $10^4$  cfu/ml.
- (b) Using a 1 ml pipette, 1 ml of the  $10^4$  solution is transferred to an appropriate agar plate and spread with a sterile glass rod. With the same pipette, another 1 ml of this solution is transferred to 9 ml of sterile saline and vortexed. This represents a 1/10 dilution, and a concentration of  $10^3$ .
- (c) The process outlined in (b) is repeated 2 more times, using a new, sterile pipette each time, to obtain 1 ml plated samples each of concentrations representing  $10^2$  and  $10^1$  cfu/ml.
- (d) Inoculated plates are carefully transferred to a holding area and materials are gathered for the next test well to be inoculated at exactly time 5 minutes. Processes (a)-(d) are repeated for each well at each sampling time (zero, 2, 4, 6, 8, and 32 hours.)

E. Plate Counts- Plates are allowed to sit upright to dry until no liquid is detectable on the surface of the agar. At that point, plates are inverted and transferred to a temperature controlled incubator for the appropriate time (See Appendix Media) Plate counts were determined by visually counting the number of cfu (colony forming units) per plate. Countable plates had between 30 to 300 cfu/plate for bacteria and yeast and 8 to 80 cfu/plate for molds. Bacterial plates that were determined to be too numerous to count (TNTC) were recorded as greater than  $3.00 \times 10^7$ , since that was the sensitivity of our test. Bacterial plates that were too few to count (TFTC), or showed no growth at all, were recorded as less than 30 cfu.

Data:

The number of cfu were determined for each lens well at each sample period. By determining the initial concentration, at time zero, it was possible to determine the concentration of bacteria in our original inoculum. Since the same inoculum was used for each of the 8 test wells for that organism, mean concentrations and kill rates were determined for the like test groups (4 Oligon vs. 4 control.) The graphs show how individual wells did through time, as well as the means of all 4 wells.

FDA protocol dictates that to meet Stand Alone criteria, contact lens care products must show a kill rate of at least 3 log units. Our graphs were designed in a log versus time format to determine if that criterion was met.

Due to difficulties with handling Fusarium in the lab and inconsistent data, those numbers were excluded and, subsequently, not graphed.

### Discussion:

All of the organisms tested under the Oligon test case failed to meet the FDA stand alone criteria for contact lens disinfection for any organism. The Oligon cases failed to kill the minimum 3 log units of any organism tested in the 8 hour test period. However, the Oligon test cases did have higher kill rates for some organisms when compared with the control, but not within 8 hours. For example, Oligon killed Pseudomonas with a greater than 3 log kill rate, but not until the 32 hour test period.

Fusarium data was collected but was not graphed. The number of cfu varied greatly between individual test wells. Fusarium has proven to be a difficult organism to work with in this type of setting. The challenge with Fusarium is, first, to ensure that the inoculating media has a sufficient number of spores, and not hyphae. Secondly, there was an apparent problem with ensuring adequate mixing when samples were taken and possible clumping of the spores in the test wells. This showed in the data by having wells sampled early in the experiment that showed no growth and later in the experiment showing cfu that were too numerous to count. In handling Fusarium, future researchers should concentrate on finding a way to ensure sufficient disbursement of the spores and on a more accurate method of determining the spore concentration in the initial inoculum.

The bacteria tested also showed slight variations between individual test wells, however, they were minimal and generally followed the same pattern through time. This, again, may point to a problem with mixing. Other methods to employ to ensure proper mixing may be as simple as keeping test cases on an agitated surface between sampling times.

Pseudomonas, one of the most pathological organisms tested and most relevant to contact lens induced infections of the eye, actually showed the best results. The Oligon test cases showed a greater than 4 log unit kill rate



over 32 hours. This is combined with the kill rate of the control wells of approximately 1 log of reduction over the same time period. The *Pseudomonas* data are also nice, since the initial concentration of organisms was within the FDA approved parameters for inocula at  $10^7$  cfu. Our lab was not equipped with a spectrophotometer and we were unable to handle the toxic barium chloride and sulfuric acid required to make the McFarland standard. Future researchers should employ either of the two methods to ensure that the starting inoculum is within FDA standards. Our method was to add organisms until the media became turbid and we assumed that we would be in the range. That method proved effective for *Pseudomonas* and *Serratia*, but not *Staphylococcus*, *Candida* or *Fusarium*.

*Staphylococcus aureus* is another organism that can cause ocular infections. Our data show that the Oligon test cases did not perform better than the control cases in eliminating *Staphylococcus* through an 8 hour test period. At time 32 hours, however, the Oligon control group showed at least 1 log kill rate more than the control. One of our difficulties with our experiment in working with *Staphylococcus* was our initial inoculum concentration was too low. This might have effected the final outcome of the data, since it might have been easier to show a higher kill rate if more of the bacteria were available to be eliminated. There is also the consideration of time with *Staphylococcus*, it could be that with our test cases, we were able to meet the 3 log kill rate, but just not within the 8 hour period. Future researchers should, again, be certain of the inoculum concentration before starting the experiment.

Unlike *Staphylococcus*, where our problem was too few of the organism starting out, *Serratia* was the opposite. We possibly had too many of the organism starting out. Limited by our dilutions, we were only able to ascertain that there were greater than  $10^7$  cfu of *Serratia* in each of the Oligon and control wells at the start of the experiment. Although the number of cfu's of *Serratia* stayed too numerous to count for the control group throughout the experiment, the Oligon group showed a greater than 1 log kill rate, on average, by time 32 hours. One interesting item to note about the Oligon test wells is that 2 of the wells consistently showed better results than the other two wells, actually showing nearly a 4 log reduction by time 32 hours. That leads us to believe that maybe there was a slight variation in the coating process of the cases that lead to the differences within the test group.

Candida, the yeast, performed much the same way as Staphylococcus. There were, perhaps, too few of the organism starting out. The Oligon group performed slightly better through time than did the control, but not near the 3 log kill rate. By time 32 hours, the Oligon group was almost 2 logs better than the control, however, the mean number of organisms *increased* at time 32 for the control. This suggests, like Fusarium, that there were possibly some problems with mixing and sampling. For all organisms tested, save for Fusarium, the Oligon test cases performed better than the controls. In the case of Pseudomonas, and possibly Staphylococcus, the performance was such that the 3 log units of reduction were met for the FDA requirement. The problem with it was in the time that it was met, that is, not within 8 hours. For a first experiment with this new and promising method of disinfecting contact lenses, we should all be excited. There are a number of studies and trials that need to be performed before this becomes a viable option for contact lens disinfection for the consumer. We believe that current studies should center on improvements on the time release capabilities of the Oligon coating and control of the silver ion concentration. Future experiments may include: the formulation of the silicon coating, the coating process itself, and the type and pH of solution/saline used in the well.

We strongly feel that the Oligon method of contact lens disinfection is the frontier for contact lens care of the future. The benefits to the contact lens wearer will be greater ease of use, better compliance and less secondary ocular complications to contact lens wear, namely, allergic reactions to preserved saline and infections of the eye. With a concerted effort by Oligon to improve on an exciting oligodynamic technology and the ability of outside labs to improve on our method to test the efficacy of the cases, we can make this technology the way of contact lens care of the future.



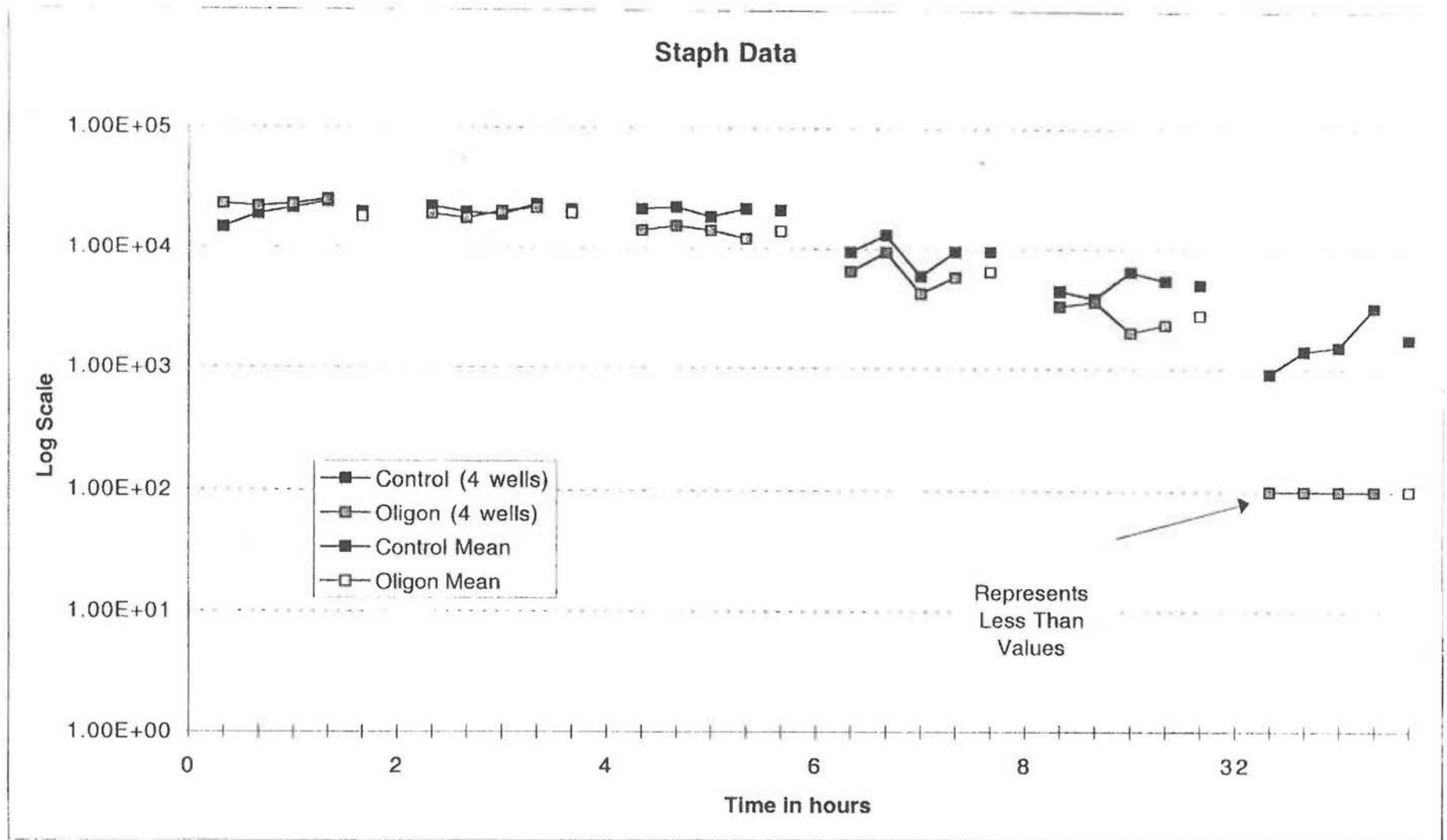

Pseudomonas Worksheet

Time (in hours)	Control (4 wells)	Oligon (4 wells)	Control Mean	Oligon Mean
0				
	1.63E+07	1.35E+07		
	2.51E+07	2.04E+07		
	1.31E+07	1.13E+07		
	1.76E+07	1.58E+07		
			1.80E+07	1.53E+07
2				
	9.60E+06	4.40E+06		
	1.02E+07	2.28E+06		
	1.38E+07	3.88E+06		
	1.02E+07	3.32E+06		
			1.10E+07	3.47E+06
4				
	1.44E+07	2.90E+06		
	1.39E+07	2.12E+06		
	1.52E+07	3.28E+06		
	1.50E+07	2.52E+06		
			1.46E+07	2.71E+06
6				
	2.70E+06	4.62E+05		
	4.10E+06	3.80E+05		
	2.19E+06	4.90E+05		
	8.90E+05	8.40E+05		
			2.47E+06	5.43E+05
8				
	2.38E+06	3.64E+04		
	2.10E+06	1.05E+05		
	2.70E+06	1.97E+05		
	2.40E+06	1.34E+05		
			2.40E+06	1.18E+05
32				
	2.70E+06	1.00E+02		
	2.63E+06	1.00E+02		
	2.80E+05	1.00E+02		
	2.38E+05	1.00E+02		
			1.46E+06	1.00E+02

Pseudomonas Data

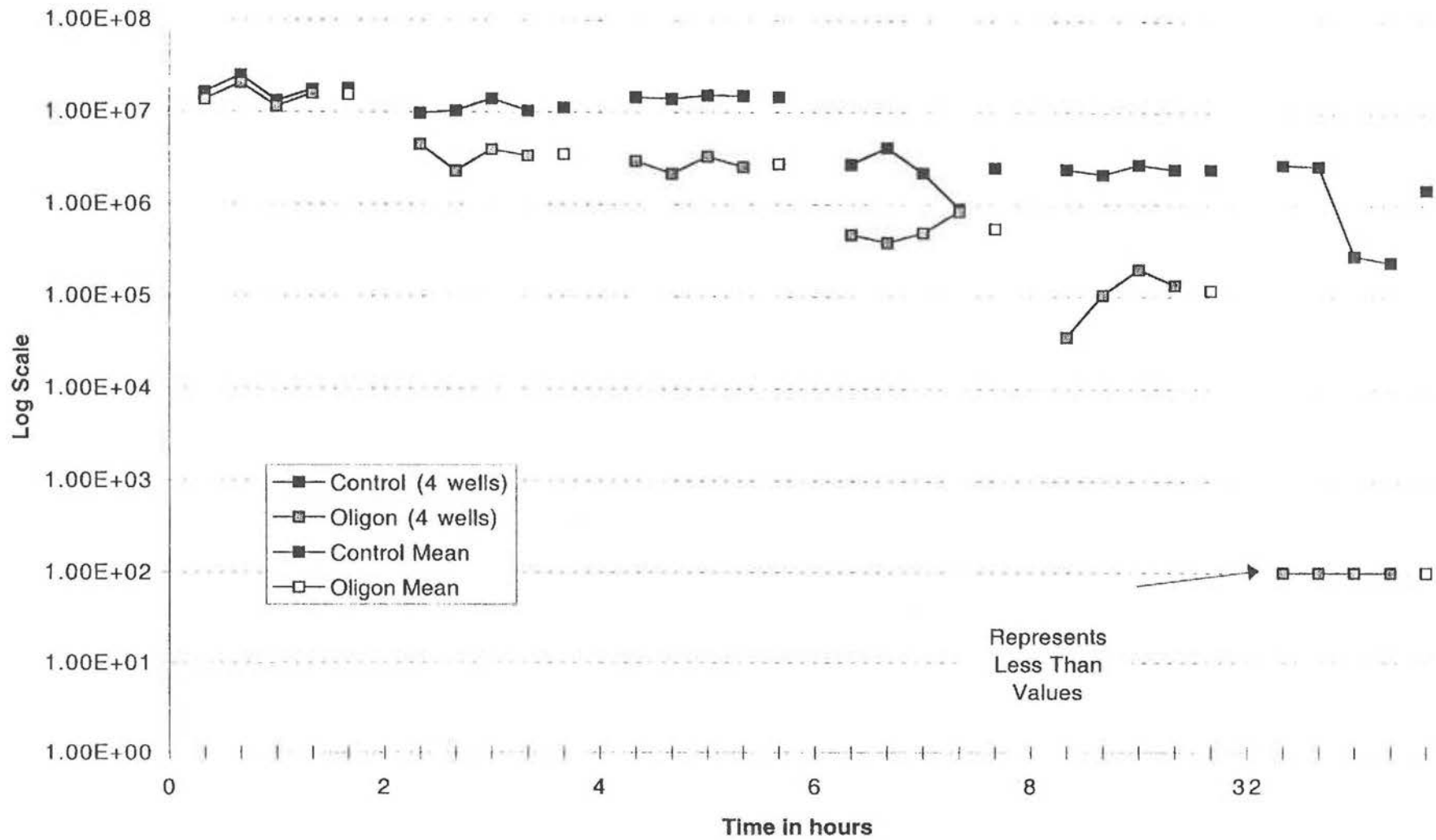

Serratia Worksheet

Time (in hours)	Control (4 wells)	Oligon (4 wells)	Control Mean	Oligon Mean
0	3.00E+07	3.00E+07		
	3.00E+07	3.00E+07		
	3.00E+07	3.00E+07		
	3.00E+07	3.00E+07	3.00E+07	3.00E+07
2	3.00E+07	3.00E+07		
	3.00E+07	3.00E+07		
	3.00E+07	3.00E+07		
	3.00E+07	3.00E+07	3.00E+07	3.00E+07
4	3.00E+07	3.00E+07		
	3.00E+07	3.00E+07		
	3.00E+07	3.00E+07		
	3.00E+07	3.00E+07	3.00E+07	3.00E+07
6	3.00E+07	7.20E+06		
	3.00E+07	7.20E+06		
	3.00E+07	2.32E+07		
	3.00E+07	3.05E+07	3.00E+07	1.50E+07
8	3.00E+07	1.18E+06		
	3.00E+07	9.30E+05		
	3.00E+07	2.90E+07		
	3.00E+07	1.70E+07	3.00E+07	1.20E+07
32	3.00E+07	2.40E+03		
	3.00E+07	1.10E+03		
	3.00E+07	1.80E+06		
	3.00E+07	1.27E+06	3.00E+07	7.68E+05

Serratia Data

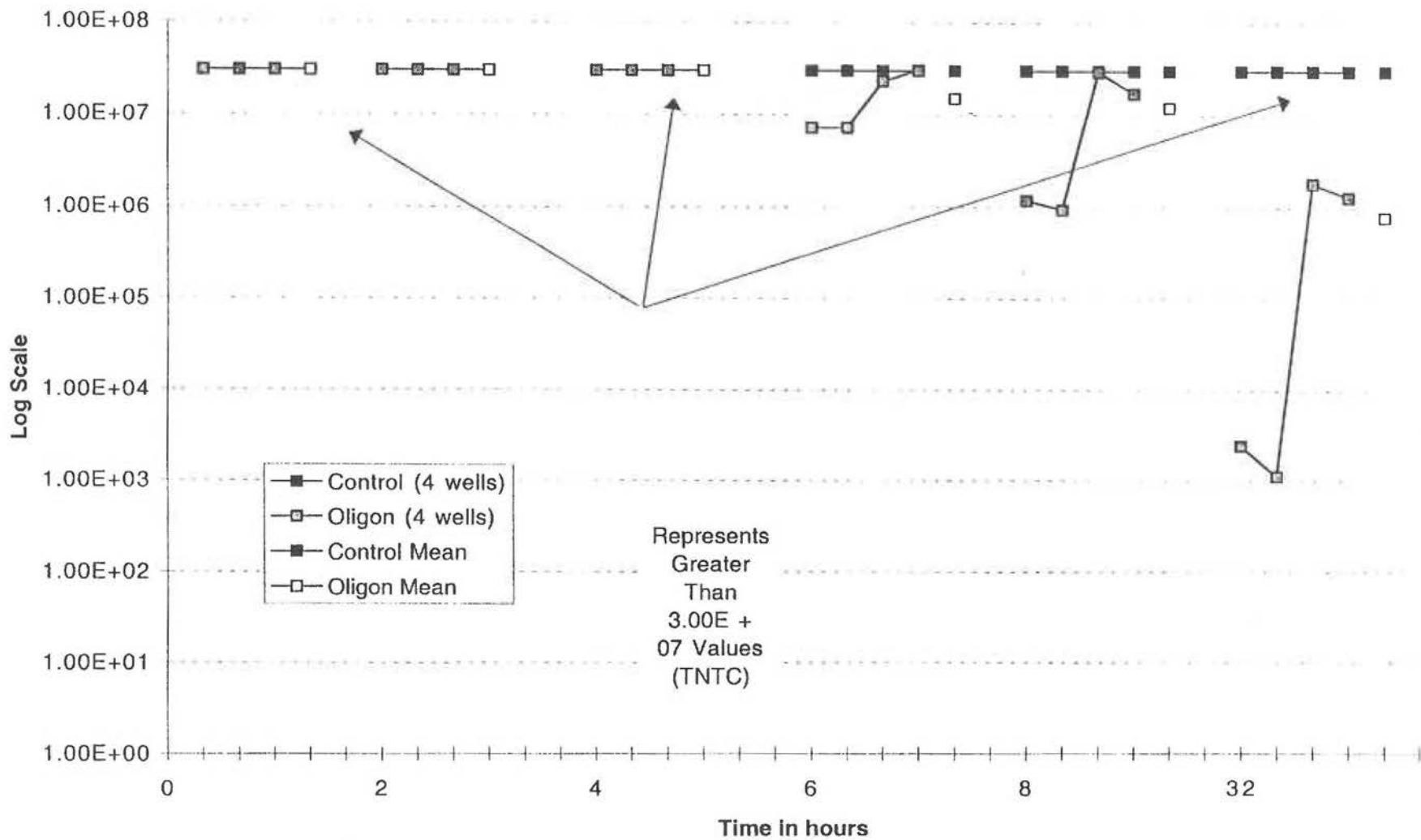



Candida Worksheet

Time (in hours)	Control (4 wells)	Oligon (4 wells)	Control Mean	Oligon Mean
0				
	5.10E+05	2.90E+05		
	8.80E+05	2.81E+05		
	3.50E+05	2.30E+05		
	6.90E+05	7.30E+05		
			6.08E+05	3.83E+05
2				
	1.82E+05	9.10E+04		
	1.90E+05	1.27E+05		
	1.21E+05	9.20E+04		
	1.02E+05	6.70E+04		
			1.49E+05	9.43E+04
4				
	1.49E+05	5.70E+04		
	1.60E+05	1.18E+05		
	7.40E+04	9.60E+04		
	2.02E+05	2.40E+04		
			1.46E+05	7.38E+04
6				
	1.12E+05	2.96E+04		
	1.72E+05	2.98E+04		
	1.09E+05	1.65E+04		
	8.90E+04	2.04E+04		
			1.21E+05	2.41E+04
8				
	8.20E+04	3.00E+04		
	7.60E+04	3.70E+04		
	2.95E+05	1.88E+04		
	2.58E+05	2.01E+04		
			1.78E+05	2.65E+04
32				
	4.00E+05	6.70E+03		
	6.30E+05	2.20E+04		
	1.25E+06	6.50E+03		
	1.19E+06	2.80E+03		
			8.68E+05	9.50E+03

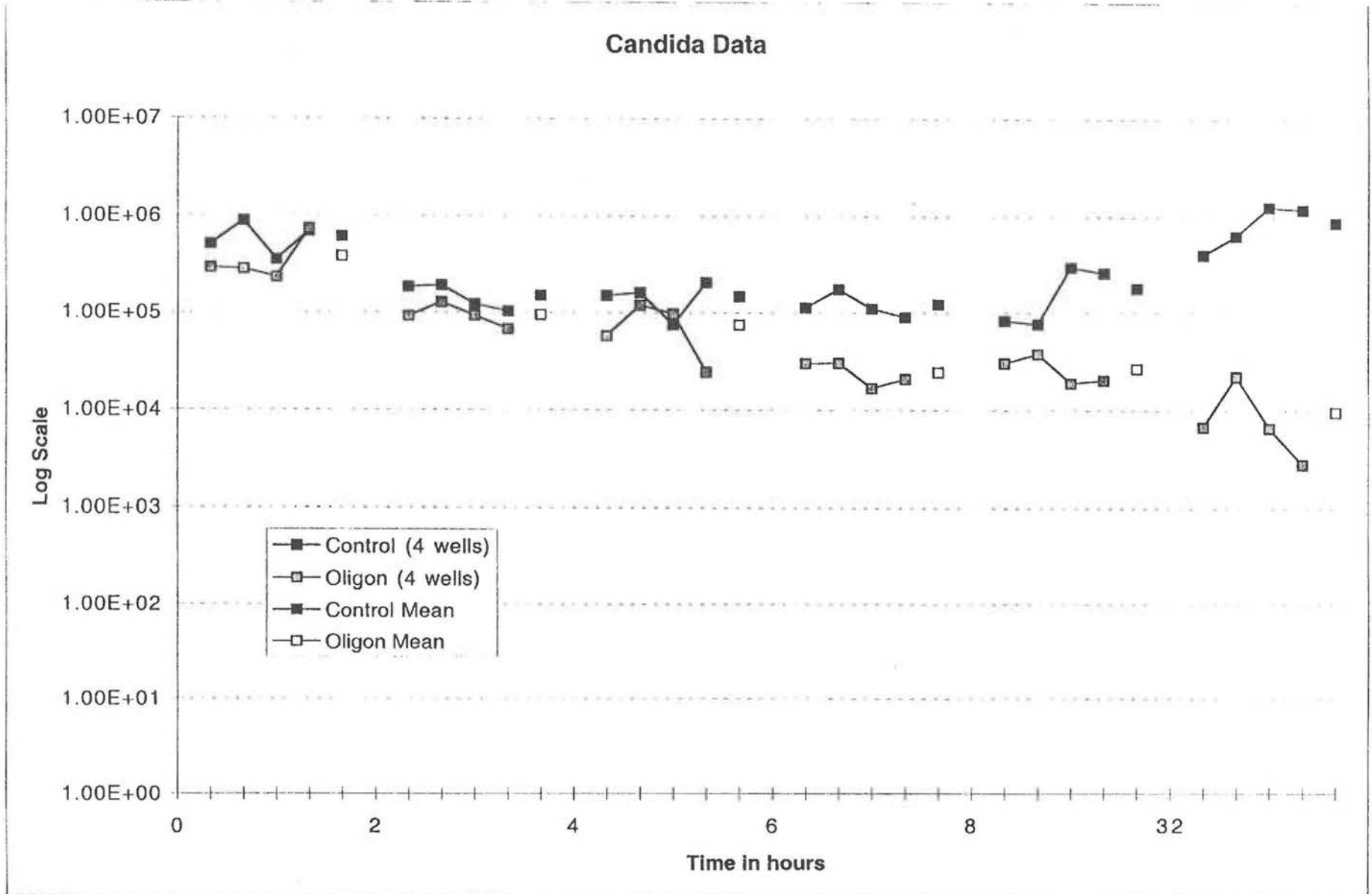

## Bibliography

### A. ANTIMICROBIAL ACTIVITY OF SILVER ION AGAINST PLANKTONIC ORGANISMS

2. "Antifungal properties of electrically generated metallic ions", 1976 Berger, et al., *Antimicrob. Agents Chemother.* **10** (5): 856-860 (organisms: *Candida* and *Torulopsis* species)
3. "Electrically generated silver ions: Quantitative effects on bacterial and mammalian cells", 1976, Berger, et al., *Antimicrob Agents Chemother.* **9** (2): 357-358 (organisms: *E. coli*, *P. aeruginosa*, *Serratia*, *S. aureus*)
4. "Inhibitory and cidal antimicrobial actions of electrically generated silver ions:", 1987, Hall, et al. *J. Oral Maxillofac. Surg.* **45**: 779-784 (organisms: *Streptococcus*, *Bacillus*, others)
5. "Electrochemical Ag<sup>+</sup> for preservative use", 1992, Simonetti, et al., *Applied Environ. Microbiol.* **58** (12): 3834-3836 (organisms: *E. coli*, *P. aeruginosa*, *C. albicans*, *A. niger*)
6. "Silver and its compounds", N. Grier in Disinfection. Sterilization and Preservation, S.S. Block, 1983, p.375-389

### B. BACTERIAL ADHESION RESISTANCE OF SILVER COATED SURFACES

2. "Prevention of catheter associated urinary tract infections by use of silver impregnated catheters", T. Lundeberg, *The Lancet*, November 1, 1986, p. 1031
3. "Silver coating of urinary catheters prevents adherence and growth of *Pseudomonas aeruginosa*", H. Liedberg and T. Lundeberg, *Urol. Res.* **17**:357-358
4. "New processes for surface treatment of catheters", P. Sioshansi, *Artificial Organs* **18**(4): 266-271 (efficacy of silver coating against *S. epidermidis* and *C. albicans*)
5. "Antibacterial activity of multilayer silver-copper surface films on catheter material", McLean, et al., *Can. J. Microbiol.* **39**: 895-899

### C. CONTACT LENS CASE CONTAMINATION

2. "Microbial Contamination of Contact Lens Care Systems:", Donzis, et al., 1987, *Am. J. Ophthalmol.* **104**: 325-333
3. "Bacillus Keratitis Associated with Contaminated Contact Lens Care Systems", Donzia, et al., 1988, *Am. J. Ophthalmol.* **105**: 195-197
4. "Contamination of Contact Lens Storage Cases by *Acanthamoeba* and Bacteria", Larkin, et al., 1990, *Br. J. Ophthalmol.* **74**: 133-135

5. "Microbial Contamination of Contact Lens Storage Cases and Solutions", Wilson, et al., 1990, *Am. J. Ophthalmol.* 110: 193-198
6. "Comparative Efficacies of Soft Contact Lens Disinfectant Solutions Against Microbial Films in Lens Cases", Wislon, et al., 1991, *Arch. Ophthalmol.* 109: 1155-1157
7. "Comparative Case Contamination: Three disinfection systems", CD McKenny and M. Ajello, 1991, *Int. Contact Lens Clin.* 18: 14-19
8. "Contamination in Contact Lens Care Systems", A kanpolat, et al., 1992, *CLAO J.* 18(2): 105-107
9. "Comparative Efficacy of Contact Lens Disinfection Solutions", R Lewis, et al., 1992, *CLAO J.* 18(1): 34-40
10. "*Acanthamoeba*, Bacterial, and Fungal Contamination of Contact Lens Storage Cases", Gray, et al., 1995, *Br. J. Ophthalmol.* 79: 601-605
11. "Microbial Contamination of Contact Lens Cases Among Medical Students", Midelfart, et al., 1996, *CLAO J.* 22(1): 21-24
12. "Fixed Lens Case Replacement Schedule Needed", *Ophthalmology Times*, 1991
13. "Bacterial Resistance Leads to Ineffective Lens Disinfection", *Ophthalmology Times*, 1991
14. "Keratitis, Hygiene, and Soft Lens Disinfection", RC Campbell, PJ Caroline, *Eye Quest Magazine*, April 5, 1994, 71-77

#### D. CONTACT LENS CARE COMPLIANCE

1. "Compliance in Contact Lens Care", MW Chun and BA Weissman, *Am. J. Optometry Physiological Optics* 64(4): 274-276
2. "A New Method to Assess Contact Lens Care Compliance", FD Turner, et al., *CLAO J.* 19(2): 108-113

#### E. BIOFILMS

1. "Adherence and Growth of Coagulase Negative *Staphylococci* on Surfaces of Intravenous Catheters", G Peters, et al., 1982, *J. Infectious Diseases* 146(4): 479-482
2. "Scanning Electron Microscopy of Bacteria Adherent to Intravascular Catheters", TR Franson, et al., 1984, *J. Clin. Microbiol.* 20(3): 500-505
3. "Tobramycin Resistance of *Pseudomonas aeruginosa* Growing as a Biofilm on Urinary Catheter Material", JC Nickel, et al., 1985, *Antimicrob. Agents Chemother.* 27(4): 619-624
4. "Extended-wear Lenses, Biofilm and Bacterial Adhesion", MM Slusher, et al., 1987, *Arch Ophthalmol.* 105: 110-115
5. "Strategies of Microbial Cell Survival in Contact Lens Cases", 1990, PJ Caroline and RC Campbell, *Contact Lens Forum*, September 1990: 27-36
6. "Slime City: When Bugs Build Skyscrapers", 1996, A Coghlan, *New Scientist*, August 31, 1996: 32-36

7. "Biofilm and Scleral Buckle Associated Infections: A Mechanism for Persistence", SP Holland, et al., *Ophthalmology* 98(6): 933-938
8. "Biomaterials and Ocular Infection", LA Wilson in Ocular Infection and Immunity, JS Pepose, et al. (eds.), Mosby, St. Louis, 1996: 215-231

#### **F. GENERAL**

1. "*Pseudomonas aeruginosa* Ocular Infections", 1993, SP Holland, et al., in *Pseudomonas aeruginosa: The Opportunistic Pathogen*, CRC Press, Inc., pp. 159-176

## Acknowledgements

The authors of this paper would like to thank their advisors, Dr. Diane Yolton and Patrick Caroline for their wisdom and guidance throughout this project.

We would also like to thank BSK (Beta Sigma Kappa) for the funding to initiate this project, as well as Implemented Inc. for their support, both logistically and monetarily to this project.

We thank Pacific University College of Optometry for the use of their facilities and resources to make this project happen.

Finally, we are grateful to the American Academy of Optometry for accepting our thesis for a poster presentation for the 1998 AAO conference in San Francisco.

## Appendix-Materials

Organisms: (by corresponding ATCC number)

#06538	Staph Aureus
#09027	Pseudomonas aeruginosa
#10231	Candida Albicans
#13880	Serratia marcescens
#36031	Fursarium solani

Pipettes: (Order numbers correspond to Daigger Supply Catalog)

1	Eppendorf Research Pipette 10-100 ul	#PX20541D
300	Eppendorf Disposable Pipette Tips	#PX20561XB
2000	Disposable Pipettes 1 ml (graduated to tip)	#PX202656
1	Pipette Aid	#PX20460F

Agar Plates: (Order numbers correspond to Daigger Supply Catalog)

1000 Petri Dishes 100x20	#PX7116B
--------------------------	----------

Agar/Neutralizer: (Order numbers correspond to VWR Scientific Products Supply Catalog)

1000 grams	Tryptone Soya Agar (TSA)	#DF0369-17
500 grams	Potato Dextrose Agar (PDA)	#DF0013-17
500 grams	Sabouraud Dextrose Agar (SDA)	#DF0109-17
200 grams	Diffco Buffer (Neutralizer)	#DF0362-15

Other Equipment needed:

- Controlled temperature water bath (for fabricating agar plates)
- Controlled climate incubators
- Sterilizer/Autoclave
- large flasks and distilled water (for making sterile water)
- approximately 1000 15 ml test tubes with racks
- approximately 50 glass rod plate spreaders-reusable if flamed in ETOH
- Autoclavable Biohazard Bags
- a buson burner
- stop watch
- lab disinfectant
- electric vortex mixer

## Appendix-Media

### Media and Incubation Conditions for Growth of Challenge Organisms

<b>Organism</b>	<b>Medium</b>	<b>Temp (C)</b>	<b>Incubation Time</b>
<i>P. aeruginosa</i>	TSA	30-35	18-24 hours
<i>S. aureus</i>	TSA	30-35	18-24 hours
<i>S. marcescens</i>	TSA	30-35	18-24 hours
<i>C. albicans</i>	SDA	20-25	42-48 hours or
	SDA	30-35	18-24 hours
<i>F. solani</i>	PDA	20-25	10-14 days



## Appendix- Timing

### **Example of Experiment Set-Up for 2 test organisms**

PT= Pseudomonas Test Wells  
PC= Pseudomonas Control Wells  
ST= Staph Test Wells  
SC= Staph Control Wells

### **Time Zero**

(table shows test organism and well number and time in hours/minutes)

<b>PT (time)</b>	<b>5 minute break 0:20</b>	<b>PC (time)</b>	<b>5 minute break 0:45</b>	<b>ST (time)</b>	<b>5 minute break 1:05</b>	<b>SC (time)</b>
PT1 0:00		PC1 0:25		ST1 0:45		SC1 1:10
PT2 0:05		PC2 0:30		ST2 0:50		SC2 1:15
PT3 0:10		PC3 0:35		ST3 0:55		SC3 1:20
PT4 0:15		PC4 0:40		ST4 1:00		SC4 1:25

**Lab Prep Time 1:30 to 1:55**

### **Time 2 Hours**

<b>PT (time)</b>	<b>5 minute break 2:20</b>	<b>PC (time)</b>	<b>5 minute break 3:45</b>	<b>ST (time)</b>	<b>5 minute break 3:05</b>	<b>SC (time)</b>
PT1 2:00		PC1 2:25		ST1 2:45		SC1 3:10
PT2 2:05		PC2 2:30		ST2 2:50		SC2 3:15
PT3 2:10		PC3 2:35		ST3 2:55		SC3 3:20
PT4 2:15		PC4 2:40		ST4 3:00		SC4 3:25

**Repeat Process for Sample Times 6, 8 and 32 hours**

## Appendix D

### McFarland nephelometer barium sulfate standards

#### Procedure:

- (a) Prepare 1% aqueous barium chloride and 1% aqueous sulfuric acid solutions.
- (b) Add the amounts indicated in Table 1 to clean, dry ampoules. Ampoules should have the same diameter as the test tube to be used in subsequent density determinations.
- (c) Seal the ampoules and label them.

#### Preparation of standards:

<u>Tube</u>	<u>BaCl<sub>2</sub></u> <u>1% (ml)</u>	<u>Sulfuric Acid</u> <u>1% (ml)</u>	<u>Bacteria Density</u> <u>(million/ml)</u>
1	0.1	9.9	300
2	0.2	9.8	600
3	0.3	9.7	900
4	0.4	9.6	1,200
5	0.5	9.5	1,500
6	0.6	9.4	1,800
7	0.7	9.3	2,100
8	0.8	9.2	2,400
9	0.9	9.1	2,700
10	1.0	9.0	3,000

## MICRO--APPENDIX B

## DISINFECTION EFFICACY TESTING

## PART 1. STAND-ALONE PROCEDURE FOR DISINFECTING PRODUCTS

I. PRINCIPLE

The stand-alone test challenges a disinfecting product with a standard inoculum of a representative range of microorganisms and establishes the extent of viability loss at pre-determined time intervals comparable with those during which the product may be used. The size of the microbial challenge chosen in this test is not intended to be representative of the likely challenge in practice, but to provide countable numbers from which estimation of the rate and extent of viability loss can be determined.

In carrying out the test for antimicrobial activity, the qualitative composition of the product should be known at the time of testing by either analytical testing or extrapolation.

Appropriate measures should be taken to inactivate or remove residual antimicrobial agents during culturing and counting of survivors and the effectiveness of these measures should be validated and the action of this process during the test should be demonstrated by the construction of suitable controls.

Three batches of product should be tested. Each batch of product should be tested with a separate inoculum preparation for each challenge organism.

II. MATERIALS AND REAGENTS

## A. Test Organisms

<i>Pseudomonas aeruginosa</i>	NCIMB 8626	ATCC 9027
<i>Staphylococcus aureus</i>	NCTC 10788	ATCC 6538
<i>Serratia marcescens</i>	NCTC 10211	ATCC 13880
<i>Candida albicans</i>	NCTC 3179	ATCC 10231
<i>Fusarium solani</i>		ATCC 36031

## B. Test Media

Potato Dextrose Agar (PDA)  
 Tryptone Soya Broth (TSB)  
 Tryptone Soya Agar (TSA)  
 Sabouraud Dextrose Agar (SDA)  
 Dulbecco's Phosphate Buffered Saline without calcium chloride and magnesium chloride (DPBS): 200 mg/L KCl, 200 mg/L  $\text{KH}_2\text{PO}_4$ , 8000 mg/L NaCl, and 2,160 mg/L  $\text{Na}_2\text{HPO}_4 \cdot 7\text{H}_2\text{O}$  or a suitable diluent.  
 Dulbecco's Phosphate Buffered Saline plus 0.05% w/v polysorbate 80 (DPBST) or a suitable diluent.  
 Validated neutralizing agents/media required (e.g., Dey-Engley Neutralizing Broth and Agar).

## C. Test Equipment

Sterile pipettes, glass beads, swabs, tubes, 100 X 20 mm petri dishes, etc., as required. Suitable instruments for spectrophotometric determination of cell density, for colony counting, and for centrifugation.

## D. Test Samples

Product samples to be tested should be representative of the product to be marketed. Aliquots should be taken directly from the final product container immediately prior to testing.

III. TEST METHOD

## A. Culture Maintenance

Cultures should be maintained in the manner recommended by the curator of the appropriate culture collection. Cultures should be no greater than five passes removed from the depository stock (ATCC, NCIB, NCTC, NCPF or other recognized culture depository.)

## B. Preparation of Microbial Challenge (Inoculum)

Test organisms should be cultured on agar as in Table 1.

Table 1

## Media and Incubation Conditions for Growth of Challenge Organisms

Organism	Medium	Temp(°C)	Incubation Time
P. aeruginosa	TSA	30-35	18-24 hrs
S. aureus	TSA	30-35	18-24 hrs
S. marcescens	TSA	30-35	18-24 hrs
C. albicans	SDA	20-25	42-48 hrs or
	SDA	30-35	18-24 hrs
F. solani	PDA	20-25	10-14 days

To harvest all cultures, use sterile DPBST or a suitable diluent, washing the surface growth and transfer to a suitable vessel. The spore suspensions may be filtered through sterile glass wool, cotton gauze or cheese cloth to remove hyphal fragments.

After harvesting, the cultured organisms may be washed using centrifugation. If centrifugation is used, each centrifugation should be conducted at 2-25°C for no longer than 10 minutes at 4000 x g or less. The bacterial suspensions may be filtered (e.g., 3 - 5 µm pore size) to produce a single cell dispersion. All challenge cell suspensions should then be adjusted with DPBST or other suitable diluent to  $1 \times 10^7$  -  $10^8$  cfu/ml. The approximate cell concentration may be estimated by measuring the turbidity of the suspension or a dilution of the suspension using a spectrophotometer. The actual concentration of cfu/ml should be determined for each suspension by the plate count method at the time of the test.

Bacterial and yeast cell suspensions should be used on the day of preparation. Bacterial and yeast cell may lose viability and resistance if not used on day of preparation. Spore suspensions may be used up to 7 days following preparation by storage under refrigeration (Avg.  $4 \pm 2^{\circ}\text{C}$ ).

C. Test Procedure

1. Prepare one tube containing a minimum of 10 ml of test solution per challenge organism. Inoculate the sample tube of the product to be tested with a suspension of test organisms sufficient to provide a final count of  $1.0 \times 10^5$  -  $1.0 \times 10^6$  cfu/ml. The volume of inoculum should not exceed 1% of the sample volume. Ensure dispersion of the inoculum by adequate mixing.
2. Store inoculated product at  $20-25^{\circ}\text{C}$ . Temperature should be monitored using a calibrated device and documented. If sensitive to light the product should be protected during the period of the test.
3. Take 1.0 ml aliquots of the inoculated product for determination of viable count at 25%, 50%, 75% and 100% of the minimum recommended disinfection time for all organisms, and, in addition, at not less than 4 times the minimum recommended disinfection time for yeast and mold. Where overnight disinfection is recommended, disinfection time is taken to be 8 hours.
4. Subject 1.0 ml aliquots removed at the specified time intervals to a suitable series of decimal dilutions in validated neutralizing media. Mix suspension well by vortexing vigorously and incubate for a suitable period of time to allow for neutralization.

If the antimicrobial agent(s) in the formulation cannot be adequately inactivated or neutralized it may be eliminated using a validated membrane filtration procedure (e.g., Micro--Appendix D).

5. Determine the viable count of organisms in appropriate dilutions by preparation of triplicate plates (unless otherwise justified) of a suitable recovery medium (e.g., TSA for bacteria and SDA for mold and yeast).

Where membrane filtration has been employed to remove/neutralize antimicrobial agents, membranes should be cultured on these media as appropriate. The agar for pour plates should be kept between  $40-50^{\circ}\text{C}$  prior to pouring. The agar media used for determination of viable counts may also contain antimicrobial inactivators or neutralizers if required.

6. Incubate bacterial recovery plates at  $30-35^{\circ}\text{C}$  for 2-4 days. Incubate yeast at  $20-25^{\circ}\text{C}$  or  $30-35^{\circ}\text{C}$  for 3-5 days and mold recovery plates at  $20-25^{\circ}\text{C}$  for 3-7 days.

7. Determine the average number of cfu on countable plates. Countable plates refer to 30 to 300 cfu/plate for bacteria and yeast, and 8 to 80 cfu/plate for mold except when colonies are observed only for the  $10^0$  or  $10^{-1}$  dilution plates. Calculate microbial reduction at the specified time points.

D. Controls

1. Inoculum Control

An inoculum count is made by dispersing an identical aliquot of the inoculum into the same volume of suitable diluent (e.g., DPBST) as used in Part 1:III.C.1 to achieve a final concentration of  $1.0 \times 10^5$  -  $1.0 \times 10^6$  cfu/ml. The volume of inoculum should not exceed 1% of the sample volume. Ensure dispersion of the inoculum by adequate mixing. This control sample should be evaluated for cfu/ml at the beginning of the test. This serves to demonstrate the suitability of the medium used for growth of the test organism and provides an estimate of the initial inoculum concentration.

2. Recovery medium control

Prepare a 1/10 dilution of the disinfecting solution in the validated neutralizing broth (1 ml into 9 ml). If a greater dilution of the test solution is required to achieve neutralization, the latter dilution should be used. Prepare a second control tube with 10 ml of a suitable diluent (e.g., TSB). Inoculate the tubes with sufficient inoculum to result in 10-100 cfu of challenge organism per plate. Incubate for an appropriate period of time at ambient temperature. Plate the appropriate aliquot from each tube onto the recovery agar plates in triplicate unless otherwise justified.

The recovery in the neutralizer broth should be at least 50% of the recovery in the second control tube. This control should be performed for each challenge organism.

IV. PERFORMANCE REQUIREMENT

- A. Control Specification

If any control value falls out of specification, the associated test is invalid and should be repeated.

- B. Primary Criteria (See Part 2, Table 2)

1. Bacteria

The number of organisms recovered per ml should be reduced by a mean value of not less than 3.0 logs within the minimum recommended disinfection period.

## 2. Molds and Yeasts

The number of organisms recovered per ml should be reduced by a mean value of not less than 1.0 log within the minimum recommended disinfection time with no increase at not less than four times the minimum recommended disinfection time.

### C. Secondary Criteria (See Part 2, Table 2)

Products failing to meet the criteria in Part I:IV.B.1 or Part 1:IV.B.2 may be evaluated by the regimen test procedure described below, provided there is a combined log reduction for the means of all bacteria of not less than 5.0 within the recommended disinfection period. The minimum acceptable mean log reduction for any single bacterial type is 1.0. Stasis for the yeast and mold (within an experimental error of  $\pm 0.5$  log) should be observed for the recommended disinfection period.

## PART 2. REGIMEN PROCEDURE FOR DISINFECTING REGIMENS

### I. PRINCIPLE

This procedure is applicable to multi-functional disinfection regimens which may include the steps of cleaning, rinsing, and soaking. In carrying out the regimen test procedure, the products should be used in the manner and quantity recommended in product labeling and/or patient instructions. The test challenges the proposed disinfection regimen with a standard inoculum of a representative range of microorganisms. The inoculum is carried through the various stages of the regimen by preliminary application to contact lenses.

The disinfecting stage of any proposed contact lens disinfection regimen evaluated by this test should have demonstrated minimum antimicrobial activity by the Stand-Alone Procedure as indicated for Regimen Qualification.

In carrying out the test, qualitative and quantitative composition of all products used in the test regimen should be known at the time of testing, either by analytical testing or extrapolation.

Appropriate measures should be taken to inactivate or remove residual antimicrobial agents during culturing and counting of the challenge organism and the effectiveness of these measures should be demonstrated by the construction of suitable controls.

A minimum of three lots of product should be tested. Each lot of product should be tested with a separate inoculum preparation for each challenge organism.

### II. MATERIALS AND REAGENTS

#### A. Test Organisms

Pseudomonas aeruginosa	NCIMB	8626	ATCC 9027
Staphylococcus aureus	NCTC	10788	ATCC 6538
Serratia marcescens	NCTC	10211	ATCC 13880
Candida albicans	NCPF	3179	ATCC 10231
Fusarium solani			ATCC 36031

#### B. Test Media

Tryptone Soya Broth (TSB)  
 Tryptone Soya Agar (TSA)  
 Sabouraud Dextrose Agar (SDA)  
 Potato-Dextrose Agar (PDA)  
 Dulbecco's Phosphate Buffered Saline without calcium chloride and magnesium chloride (DPBS): 200 mg/L KCl, 200 mg/L KH<sub>2</sub>PO<sub>4</sub>, 8000 mg/L NaCl, and 2,160 mg/L Na<sub>2</sub>HPO<sub>4</sub>•7H<sub>2</sub>O or suitable diluent.  
 Dulbecco's Phosphate Buffered Saline plus 0.05% w/v polysorbate 80 (DPBST) or suitable diluent. Validated neutralizing agents/media as required (e.g., Dey-Engley Neutralizing Broth and Agar).



C. Test Equipment

Sterile pipettes, glass beads, swabs, tubes, filters, etc., as required. Suitable instruments for spectrophotometric determination of cell density, for colony counting, and for centrifugation.

D. Test Samples

Test product samples to be tested should be representative of the product to be marketed. Aliquots should be taken directly from the final product container immediately prior to testing. All regimen items, including cases, lenses, cleaning devices, etc., should be new and unused. If the test regimen results will be directly compared with results for a predicate device, then a predicate device from the same product category should be used for the comparison (e.g., a hydrogen peroxide product should be compared to a predicate hydrogen peroxide system and a multi-purpose product should be compared to a predicate multi-purpose product). Refer to Part 2:IV (PERFORMANCE REQUIREMENT).

III. TEST METHODS

A. Culture Maintenance

Cultures should be maintained in the manner recommended by the curator of the appropriate culture collection. Cultures should be no greater than 5 passes removed from the depository stock (ATCC, NCIB, NCTC, NCPF or other recognized culture depository).

B. Preparation of Microbial Challenge (Inoculum)

Test organisms should be cultured and harvested as in Part 1:III.B.

After harvesting, organic soil consisting of heat killed yeast cells and heat inactivated serum, should be combined with the test organism to result in an initial concentration of  $1 \times 10^7 - 10^8$  cfu/ml.

Prepare organic soil as follows. Culture *S. cerevisiae* on SDA at 20-25°C for 48 hrs. Harvest as in Part 1:III.B. Heat kill the suspension at  $100 \pm 2^\circ\text{C}$  for 10 minutes. Centrifuge at no more than 5000 X g for a maximum of 30 minutes. Resuspend in bovine serum which has been heated at 56°C for 30 minutes to inactivate complement. The concentration of *S. cerevisiae* in serum should be  $1 \times 10^7 - 10^8$ .

Centrifuge test organism suspension. Resuspend in organic soil to a concentration  $1 \times 10^7 - 10^8$  cfu/ml. This is the inoculum to be used in the following procedure.

## C. Test Procedure

## 1. Lens Inoculation

The test should be conducted with lens types representative of those with which the regimen is intended to be used (e.g., low water non-ionic, high water ionic, silicone acrylate, etc.).

Inoculate eight lenses per lot of test product per microbial species tested; to qualify for all hydrophilic lenses use four (4) non-ionic low water lenses and four (4) ionic high water lenses. For hydrophobic lenses, use four (4) silicone-acrylate and four (4) fluorosilicone-acrylate lenses.

Organism 1	<u>Hydrophilic Lenses</u>	
	Group I Material	Group IV Material
Lot 1 of Test Product	4 lenses	4 lenses
Lot 2 of Test Product	4 lenses	4 lenses
Lot 3 of Test Product	<u>4 lenses</u>	<u>4 lenses</u>
	12 lenses	12 lenses

Organism 1	<u>Hydrophobic Lenses</u>	
	Silicone-Acrylate	Fluorosilicone-Acrylate
Lot 1 of Test Product	4 lenses	4 lenses
Lot 2 of Test Product	4 lenses	4 lenses
Lot 3 of Test Product	<u>4 lenses</u>	<u>4 lenses</u>
	12 lenses	12 lenses

For hydrophilic or hydrophobic lenses, a total of 120 lenses (24 for each organism/60 lenses in each representative lens material) will be needed to test all 5 organisms.

Place test and control lenses, concave surface uppermost in a sterile petri dish.

Inoculate each lens by placing 0.01 ml of inoculum on the under surface of the lens at the point of contact between the petri dish and the lens, and 0.01 ml of inoculum on the top surface of the lens.

Allow the inoculum to absorb to each lens for 5-10 min. at 20-25°C.

## 2. Lens Treatment

After inoculum absorption, treat lenses as described in the manufacturer's consumer instructions for lens disinfection, including all steps of cleaning, rinsing and soaking specified by the manufacturer. Cleaning and rinsing

procedures (e.g., rubbing and rinsing times and rinse volumes) should be performed in identical fashion for the predicate device and the test sample, unless otherwise stated in the manufacturer's consumer instructions for lens care. Test protocols should specify these parameters.

3. Recovery of Surviving Challenge Organisms (e.g., Micro-- Appendix D Membrane Filtration Procedure)
  - a. Dispense suitable volume of validated neutralizing medium into filtration apparatus.
  - b. Transfer entire content of each test lens case (lens and solution) into the neutralizing medium in the filtration apparatus. The neutralization exposure time prior to filtration should be determined in the validation study.
  - c. Apply vacuum and filter solution. Rinse the filter two additional times with the neutralizing medium.
  - ~~d.~~ Aseptically transfer the lens onto a bed of agar medium appropriate for recovery of the test organism. Pour 40-50°C agar medium (same as bed agar above) over the lens to cast it.
  - e. Apply the test filter to the surface of a plate of appropriate solid media (could be the same as used in Part 2:III.C.3.d).
  - f. Incubate bacterial recovery plates at 30-35°C for 2-4 days. Incubate yeast recovery plates at 20-25°C or 30-35°C for 3-5 days and mold recovery plates at 20-25°C for 3-7 days.

#### D. Controls

##### 1. Lens Inoculation Control

For each microbial species tested transfer 3 inoculated lenses to tubes of TSB (for bacteria and yeasts) or SDB (for fungi) as appropriate. Vortex for 30 seconds. Serially dilute and plate out appropriate dilutions to permit a count of viable cells present.

This count confirms that the number of organisms on the lens at the time of regimen challenge is adequate. The mean of the 3 counts should be not less than  $2.0 \times 10^5$ .

## 2. Neutralization and Recovery Control

Prepare filtration apparatus in triplicate (unless otherwise justified) as in Part 2:III.C.3 with suitable volumes of neutralizing medium and disinfecting solution. Add 5 to 50 cfu of challenge organism, filter and cultivate as outlined in Part 2:III.C.3.

Confirm inoculum on suitable medium in triplicate unless otherwise justified.

The recovery in the neutralizer broth should be at least 50% of the inoculum.

## IV. PERFORMANCE REQUIREMENT

Bacteria, molds and yeast (See Table 2)

Less than or equal to 10 cfu recovered from each lens and test filter combination for each test organism. Alternatively, the average number of surviving organisms recovered on the lens and the respective test filter should be shown to be substantially equivalent to results obtained for the predicate device(s) when tested according to this regimen procedure. Organism counts (average for each organism) may be considered to be substantially equivalent if the difference between the subject device and the predicate device is less than or equal to 0.5 log.

Table 2  
SUMMARY OF RECOMMENDED PERFORMANCE  
CRITERIA FOR CONTACT LENS DISINFECTION PROCEDURES

PRODUCT	MEAN LOG REDUCTION AT DISINFECTION TIME				
	FUNGI		BACTERIA		
	FS <sup>a</sup>	CA	SM	PA	SA
Stand-Alone Criteria	1	1	3	3	3
Regimen Qualification	b	b	c	c	c
Regimen Criteria	d	d	d	d	d

a FS = *F. solani* ATCC 36031,  
CA = *C. albicans* ATCC 10231,  
SM = *S. marcescens* ATCC 13880,  
PA = *P. aeruginosa* ATCC 9027,  
SA = *S. aureus* ATCC 6538

b Stasis with an experimental error of  $\pm 0.5$  log at the disinfection time.

c The minimum acceptable log reduction for the mean value of all 3 bacteria combined should be 5.0. The minimum acceptable log reduction for any single bacterial type should be 1.0.

d Less than or equal to 10 cfu per lens and test filter combination from 0.01 ml of  $1 \times 10^7$  to  $1 \times 10^8$  inoculum OR

The average combined number of surviving organisms recovered on the lens and the respective test filter must be shown to be substantially equivalent to the predicate device(s).

**MICRO--APPENDIX C**  
**BACTERIOSTASIS TEST**

I. PRINCIPLE

Bacteriostasis testing is performed for multi-dose saline products which do not contain conventional preservatives, yet do contain bacteriostatic agents (e.g., borate, boric acid, potassium sorbate, and EDTA). For these products, which do not meet the preservative efficacy criteria described in Micro--Appendix A, a discard date should be determined on the basis of the product's bacteriostatic activity. The bacteriostasis test is a modification of the preservative efficacy test procedure.

Three lots of product should be tested. Each lot of product should be tested with a separate inoculum preparation for each challenge organism.

II. MATERIALS & REAGENTS

A. Test Organisms

<i>Pseudomonas aeruginosa</i>	NCIMB 8626	ATCC 9027
<i>Staphylococcus aureus</i>	NCTC 10788	ATCC 6538
<i>Escherichia coli</i>	NCIB 8245	ATCC 8739
<i>Candida albicans</i>	NCPF 3179	ATCC 10231
<i>Aspergillus niger</i>	IMI 149007	ATCC 16404

B. Test Media

Tryptone Soya Broth (TSB), Tryptone Soya Agar (TSA), Sabouraud Dextrose Agar (SDA), Dulbecco's Phosphate Buffered Saline without calcium chloride and magnesium chloride (DPBS): 200 mg/l KCl, 200 mg/l  $\text{KH}_2\text{PO}_4$ , 8000 mg/l NaCl, and 2,160 mg/l  $\text{Na}_2\text{HPO}_4 \cdot 7\text{H}_2\text{O}$  or suitable diluent

Dulbecco's Phosphate Buffered Saline plus 0.05% w/v polysorbate 80 (DPBST) or suitable diluent

Validated neutralizing agents/media as required (e.g., Dey-Engley Neutralizing Broth and Agar).

C. Test Equipment

Sterile pipettes, glass beads, swabs, tubes, 100 X 20 mm petri dishes, etc., as required. Suitable instruments for spectrophotometric determination of cell density, for colony counting, and for centrifugation.

D. Test Samples

Product samples to be tested should be representative of the product to be marketed. Prepare one tube containing a minimum of 10 ml of test solution per challenge organism. The largest container size proposed for the product should be used.

### III. TEST METHOD

#### A. Culture Maintenance

Cultures should be maintained in the manner recommended by the curator of the appropriate culture collection. Cultures should be no greater than 5 passes removed from the depository stock (ATCC, NCIB, NCTC, NCPF or other recognized culture depository).

#### B. Preparation of Microbial Challenge (Inoculum)

Test organisms should be cultured on agar as in Table 1.

Table 1: Media & Incubation Conditions for Growth of Challenge Organisms

Organism	Medium	Incubation	
		Temp °C	Time
* Pseudomonas aeruginosa	TSA	30-35	18-24h
* Staphylococcus aureus	TSA	30-35	18-24h
Escherichia coli	TSA	30-35	18-24h
* Candida albicans	SDA	20-25	42-48 or
	SDA	30-35	18-24h
Aspergillus niger	SDA	20-25	7 days

To harvest all cultures, use sterile DPBST or a suitable diluent, washing the surface growth and transfer to a suitable vessel. The spore suspensions may be filtered through sterile glass wool, cotton gauze or cheese cloth to remove hyphal fragments.

After harvesting, the cultured organisms may be washed using centrifugation. If centrifugation is used, each centrifugation should be conducted at 2-25°C for no longer than 10 minutes at 4000 x g or less. The bacterial suspensions may be filtered (e.g., 3 - 5 µm pore size) to produce a single cell dispersion. All challenge cell suspensions should then be adjusted with DPBST or other suitable diluent to  $1 \times 10^7$  -  $1 \times 10^8$  cfu/ml or cell concentration sufficient to result in final concentration of  $1 \times 10^5$  -  $1 \times 10^6$  cfu/ml in the product. The approximate cell concentration may be estimated by measuring the turbidity of the suspension or a dilution of the suspension using a spectrophotometer. The actual concentration of cfu/ml should be determined for each suspension by the plate count method at the time of the test.

Bacterial and yeast cell suspensions should be used on the day of preparation. Bacterial and yeast cells may lose viability and resistance if not used on the day of preparation. Spore suspensions may be used up to 7 days following preparation by storage under refrigeration (Avg.  $4 \pm 2^\circ\text{C}$ ).

F.S.  
S.M.

## C. Test Procedure

1. Inoculate the sample product to be tested with a suspension of test organisms sufficient to provide a final count of  $1.0 \times 10^5$  -  $1.0 \times 10^6$  cfu/ml. The volume of inoculum should not exceed 1% of the sample volume. Ensure dispersion of the inoculum by adequate mixing.
2. Store inoculated product at 20-25°C. Temperature should be monitored using a calibrated device and documented. If sensitive to light the product should be protected during the period of the test.
3. Take 1.0 ml aliquots of the inoculated product for determination of viable count at 7, 14, 21, and 28 days. If longer discard dates are desired, continue sampling periodically thereafter.
4. Subject 1.0 ml aliquots removed at the specified time intervals to a suitable series of decimal dilutions in validated neutralizing media. Mix suspension well by vortexing vigorously and incubate for a suitable period of time to allow for neutralization.

If the antimicrobial agent(s) in the formulation cannot be adequately inactivated or neutralized it may be eliminated using a validated membrane filtration procedure (e.g., Micro-Appendix D).

5. Determine the viable count of organisms in appropriate dilutions by preparation of triplicate plates (unless otherwise justified) of suitable recovery medium (e.g., TSA for bacteria and SDA for mold and yeast). The agar for pour plates should be kept between 40-50°C prior to pouring. The agar media used for determination of viable counts may also contain antimicrobial inactivators or neutralizers if required. Where membrane filtration has been employed to remove/neutralize antimicrobial agents, membranes should be cultured on these media as appropriate.
6. Incubate bacterial recovery plates at 30-35°C for 2-4 days. Incubate yeast at 20-25°C or 30-35°C for 3-5 days and mold recovery plates at 20-25°C for 3-7 days.
7. Determine the average number of cfu on countable plates and record. Countable plates refer to 30-300 cfu/plate for bacteria and yeast, and 8-80 cfu/plate for mold except when colonies are observed only for  $10^0$  or  $10^{-1}$  dilution plates. Calculate microbial reduction at the specified time points.
8. The concentration of survivors should be calculated at each time point.



D. Controls

1. Inoculum Controls

The initial inoculum concentration should be calculated by dispersing an identical aliquot of the inoculum into the same volume of a suitable diluent (e.g., DPBST) as used in III.C.1 to achieve a final concentration of  $1.0 \times 10^5$  -  $1.0 \times 10^6$  cfu/ml. Ensure dispersion of the inoculum by adequate mixing. This control sample should be evaluated at the same time as the zero time sample. This serves to demonstrate the suitability of the medium used for growth of the test organism and provides an estimate of the initial inoculum concentration.

2. Recovery Medium Control

Qualify the neutralizing agent/medium for the product initially and periodically thereafter. Prepare a 1/10 dilution of the product in the validated neutralizing broth (1 ml into 9 ml). If a greater dilution of the test solution is required to achieve neutralization, the latter dilution should be used. Prepare a second control tube with 10 ml of a suitable diluent (e.g., TSB). Inoculate the tubes with sufficient inoculum to result in 10 - 100 cfu of challenge organism per plate. Incubate for an appropriate period of time at ambient temperature. Plate the appropriate aliquot from each tube onto the recovery agar plates in triplicate unless otherwise justified. The recovery in the neutralizer broth should be at least 50% of the recovery in the second control tube. This control is to be performed for each challenge organism.

IV. PERFORMANCE CRITERIA

A. Bacteria

The concentration of each bacterial challenge organism should remain at the initial level or decrease.

B. Molds and Yeasts

The concentration of the yeast and mold should remain at initial levels or decrease within an experimental error of  $\pm 0.5$  log.

C. The product should be labeled to discard the container after it has been opened for the number of days which corresponds to time point previous to the point at which any organism shows an increase in number (see example). The container label should include a space on which to record the date opened.

Example:

(Concentration in Abbreviated Log Value)

	0	7	DAY 14	21	28	35
E. coli	$10^5$	$10^3$	<10	$10^1$	$10^2$	$10^3$
P. aeru.	$10^5$	$10^3$	$10^3$	$10^2$	$10^3$	$10^4$
S. aureus	$10^5$	<10	<10	<10	<10	<10
C. alb.	$10^5$	$10^5$	$10^4$	$10^2$	<10	<10
A. niger	$10^5$	$10^4$	$10^3$	$10^4$	$10^4$	$10^5$

Cut off point: E. coli 14 days  
P. aeru. 21 days  
A. niger 14 days

The use of the above hypothetical product is limited to 14 days after opening.

**United States Patent** [19]  
Milder

(11) Patent Number: **5,498,248**  
(45) Date of Patent: **Mar. 12, 1996**

[54] **IONTOPHORETIC STRUCTURE FOR MEDICAL DEVICES**

- [75] Inventor: **Fredric L. Milder, Brookline, Mass.**  
[73] Assignee: **Implumed, Inc., Brookline, Mass.**  
[21] Appl. No.: **212,157**  
[22] Filed: **Mar. 14, 1994**

**Related U.S. Application Data**

- [62] Division of Ser. No. 975,597, Nov. 12, 1992, Pat. No. 5,322,520  
[51] Int. Cl.<sup>6</sup> **A61M 5/32; A61M 25/00**  
[52] U.S. Cl. **604/265; 604/280; 604/20; 607/149**  
[58] Field of Search **604/265, 280; 604/20, 21, 8, 266, 27, 173; 128/640, 642; 607/149, 152, 153, 122**

[56] **References Cited**

**U.S. PATENT DOCUMENTS**

3,659,588	5/1972	Kahn et al.	604/280 X
3,964,477	6/1976	Ellis et al.	
4,027,393	6/1977	Ellis et al.	
4,054,139	10/1977	Crossley	
4,126,937	11/1978	Ellis et al.	
4,308,859	1/1982	Child	
4,913,438	2/1982	Greenbarch	604/20
4,411,648	10/1983	Davis et al.	604/21
4,474,570	10/1984	Adlart et al.	604/20
4,476,590	10/1984	Scalen et al.	
4,483,688	11/1984	Aldyama	604/265
4,564,361	1/1986	Akiyama	604/265
4,569,673	2/1986	Teal	604/20
4,603,152	7/1986	Laurin et al.	604/265
4,886,075	12/1989	Juncoy	
4,886,505	12/1989	Haynes et al.	604/265
5,048,140	9/1991	Bronner et al.	604/266
5,057,072	10/1991	Phipps	604/20
5,084,006	1/1992	Lew et al.	604/20
5,154,165	10/1992	Elliott et al.	604/20 X
5,324,275	6/1994	Reed et al.	604/265
5,328,451	7/1994	Davis et al.	604/20
5,421,982	6/1995	Doda et al.	204/414

**FOREIGN PATENT DOCUMENTS**

0206024	12/1986	European Pat. Off.	604/265
3830359	12/1989	Germany	
0000899	of 1980	United Kingdom	604/20
15R2016	12/1980	United Kingdom	
WO9116946	11/1991	WIPO	

**OTHER PUBLICATIONS**

Booth et al., *Comprehensive Polymer Science*, "Electrical Conductivity", vol. 2 (1989), pp. 687, 688, 701, 702 (Bloor).  
J. A. Spadaro et al., *Antibacterial Effects of Silver Electrodes with Weak Direct Current, Antimicrobial Agents and Chemotherapy*, vol. 6, No. 5, Nov., 1974, pp. 637-642.  
C. P. Davis et al., *Electrode and Bacterial Survival With Iontophoresis in Synthetic Urine*, *The Journal of Urology*, vol. 147, May, 1992, pp. 1310-1313.

*Primary Examiner*—C. Fred Rosenbaum  
*Assistant Examiner*—V. Alexander  
*Attorney, Agent, or Firm*—Weingarten, Schurgin, Gagnebin & Hayes

[57] **ABSTRACT**

An iontophoretic structure for medical devices is provided that uses controlled electrical current derived from two dissimilar galvanic materials to drive oligodynamic metal ions into solution to kill bacteria on and near the device to which the structure is affixed. In one embodiment, a first galvanic material separated from a second galvanic material by a resistive material produces an anti-bacterial current flow when placed in contact with an electrolytic fluid. In another embodiment, a cylindrical elastomeric catheter incorporates a first and a second galvanic material separated by a resistive material which controls a current flow between the galvanic materials when the catheter is immersed in an electrolytic fluid. The galvanic materials can be dissimilar metal powders embedded in a conductive polymer substrate that forms an iontophoretic composite material, or dissimilar metals arranged in layers separated by a resistive layer. In yet another embodiment, the iontophoretic composite material is configured as an infection control sleeve that covers a portion of an ordinary catheter or cannula. Methods of protecting implantable medical devices and body structures with the iontophoretic structures are also provided.

15 Claims, 3 Drawing Sheets

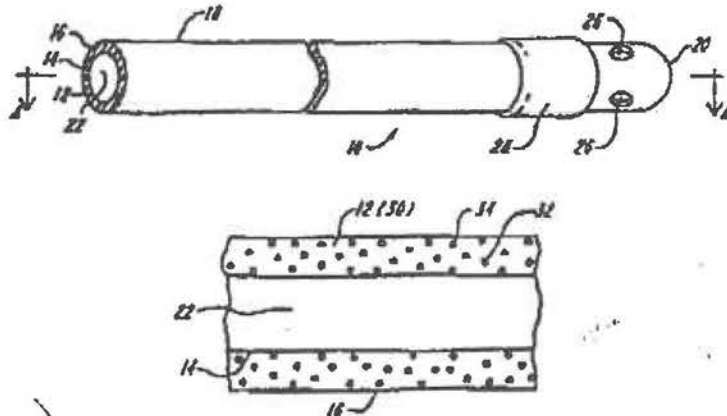

nanca fees  
rs and six  
after upon  
ing of the  
ant of the  
before the  
expire as of

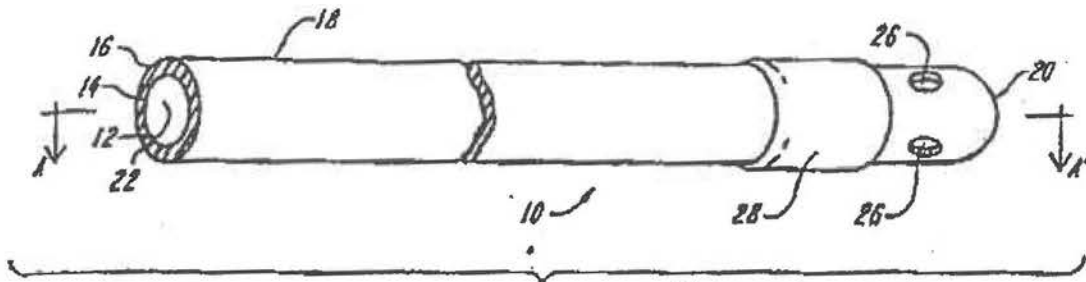

FIG. 1

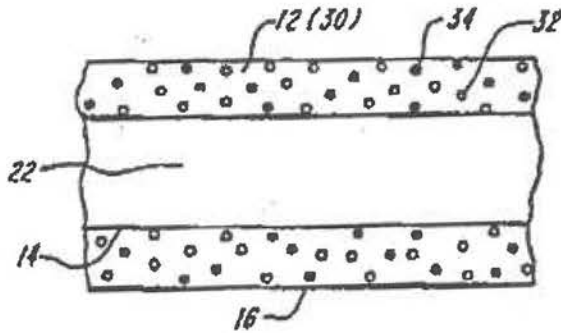

FIG. 2

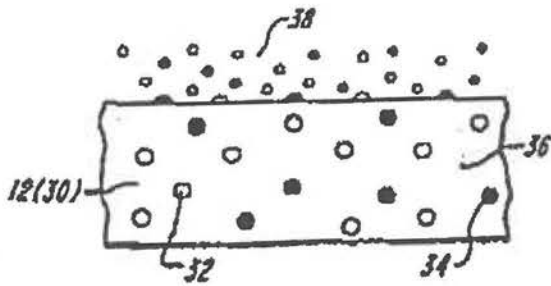

FIG. 3

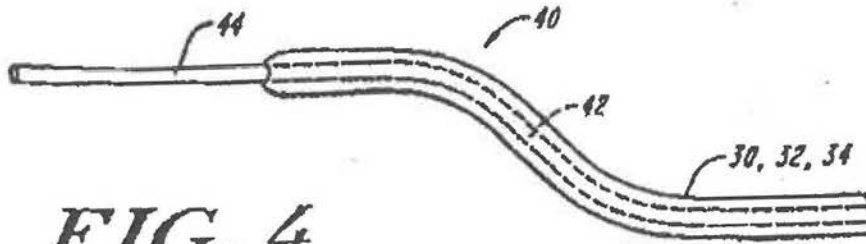
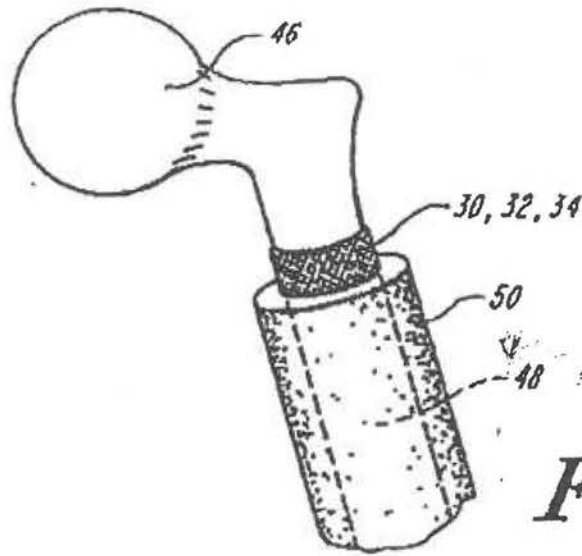
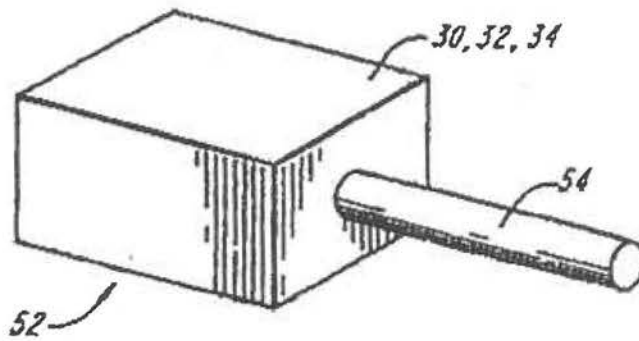

FIG. 4



**FIG. 5**



**FIG. 6A**

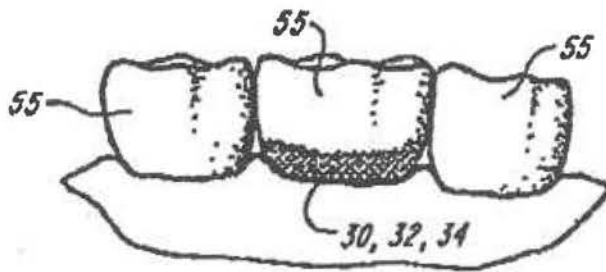

**FIG. 6B**

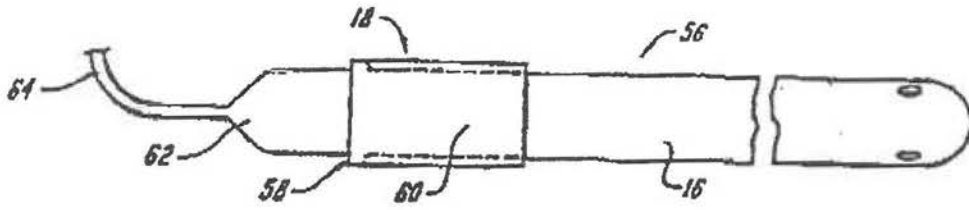

FIG. 7

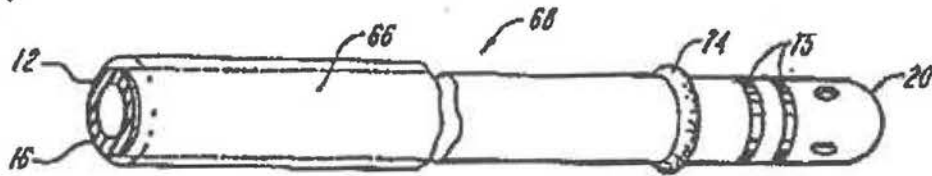

FIG. 8

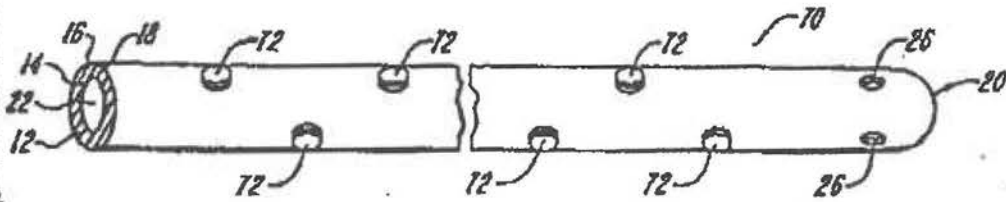

FIG. 9

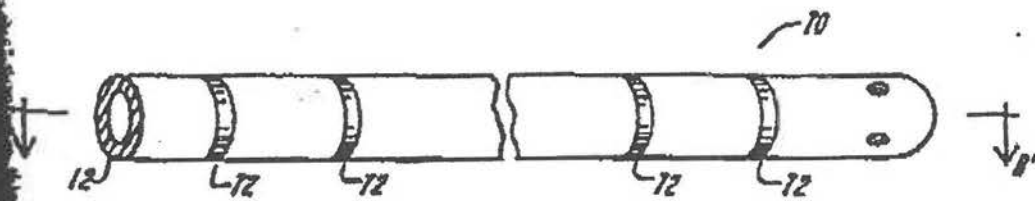

FIG. 10

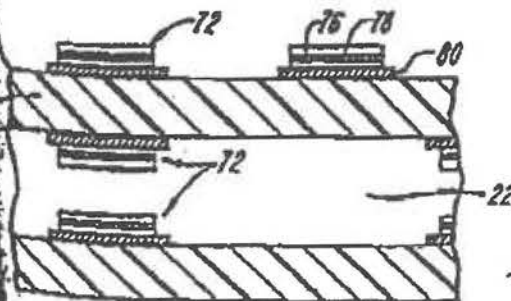

FIG. 11



# 1

## IONTOPHORETIC STRUCTURE FOR MEDICAL DEVICES

### RELATED APPLICATION

This application is a divisional of U.S. patent application Ser. No. 07/975,597, filed Nov. 12, 1992, entitled, IONTOPHORETIC STRUCTURE FOR MEDICAL DEVICES now U.S. Pat. No. 5,322,520.

### FIELD OF THE INVENTION

The invention relates to oligodynamic iontophoresis, and more particularly to an electrically conductive structure for medical devices that reduces or eliminates bacterial infection by killing bacteria with controlled oligodynamic iontophoresis.

### BACKGROUND OF THE INVENTION

Oligodynamic metals, such as silver, are effective in minute quantities as bacteriostats and bactericides. The most active form of these oligodynamic metals is as ions in solution. While the precise nature of the bactericidal effect is unknown, it is believed to involve altering the function of the cell membrane or linking to the cell's DNA to disrupt cell function. The bactericidal action is effective against a broad spectrum of bacteria, including all of the common strains which cause infection. When these metals are used in the minute concentrations required to kill or stem the growth of bacteria, they do not have any detrimental effect on normal mammalian cells.

Silver is used routinely in antibacterial salves, such as silver sulfadiazine, and has also been used in clinical trials in wet gauze for burn dressings. Medical devices, such as catheters, with silver impregnated in a soluble collagen or polymer coating are also known. After these catheters are placed, the coating slowly dissolves and the silver is released over time into the environment. The infection rates with these products are reported to be two to four times lower than standard catheters.

One catheter that uses silver as an antibacterial agent has had only limited success because the device, consisting of a silver impregnated collagen cuff which is inserted just below the skin, is difficult to place correctly. The cuff is also expensive, increasing the cost of a central venous catheter almost three-fold. Other catheters for reducing infection use well known approaches, most of them varying only in the type and solubility of the silver or silver-alloy coating.

Many of the prior art catheters that use oligodynamic metals as bacteriostats fail to adequately prevent infection for one or more of the following reasons: 1) Silver released from soluble coatings is not always in the same charge state and often is not charged at all, therefore its bactericidal potential is not optimized; 2) With soluble-coated catheters, once the coating dissolves, usually over about two weeks there is no further antibacterial protection; 3) A non-soluble silver, silver alloy or silver-oxide coating can prevent colonization of the catheter to a limited extent, but the oligodynamic metal is not released into the surrounding fluid or tissue; 4) Due to the substantial change in the catheter placement procedure, the use of these catheters requires additional personnel training; and 5) Although infection can enter the body through either the interior or the exterior of the catheter, not all catheters provide both interior and exterior protection. Furthermore, despite the capability of silver-alloy coated devices to produce a two to four fold

reduction in bacterial colonization, their high cost greatly detracts from their modest capabilities.

Research from the 1970's onward has been directed toward improving the antibacterial effects of oligodynamic metals by electrically injecting the metal ions into solution. This process, known as oligodynamic iontophoresis, is capable of reducing bacterial colonization fifteen to one-hundred fold. Iontophoresis describes the movement of ions in a conductive fluid under the influence of low-strength electric fields, and in this context refers to the forcing of ions into a conductive fluid environment using minute electric currents. For example, if two electrodes made of a metal, such as silver, are introduced into a conductive medium, such as saline, blood or urine, and an electrical potential is applied across the electrodes, silver ions are driven into solution creating an enhanced bactericidal effect. The current required to safely drive a sufficient amount of silver ions into solution to control infection is in the range of 1 to 400 microamperes. This current range does not cause localized cell necrosis and it is below the sensory or pain threshold.

Despite its great potential, the oligodynamic iontophoresis phenomenon has found limited use in conjunction with medical devices, although urological or Foley catheters have progressed to animal experiments. With respect to Foley catheters, researchers have identified several deficiencies in prior art devices. Foremost is that the electrodes used to force ions into solution wear out, or corrode, at the interface between air and the conductive medium. This problem probably also arises in blood or saline environments as well as urine. Other significant drawbacks with prior art iontophoretic devices include bulky, current-controlled power sources required for driving the electrodes; electrode configurations that do not protect both the outside and the inside of the catheter; and manufacturing processes that are labor intensive.

An example of an infection control catheter that uses separate electrodes on the catheter and an external power supply to drive ions into solution is U.S. Pat. No. 4,411,648 to Davis. Other prior art oligodynamic iontophoresis devices do not use external power supplies. For example, U.S. Pat. No. 4,886,505 to Haynes, teaches placing two metals in direct physical contact to produce electrical currents. The currents produced, however, are likely to be too large to be safely used and possibly will alter the pH of the environment. In German Patent Document DE 3,830,359, two dissimilar metal powders not in electrical contact with each other are embedded in a nonconductive catheter material, such as electrically insulating polymers. Because of the separation of dissimilar metals by an insulator, it is not likely that there is any iontophoresis effect in this device as a result of a potential being created by the dissimilar metals, except for the possibility of when a biofilm forms on the catheter surface to complete the circuit. Were an electrical circuit to be formed in this manner, the current density would not be regulated or predictable, and the current produced therefore could be either too high to be safe or too low to be effective.

An oligodynamic iontophoresis catheter which uses the properties of metals to generate a current and to form an ion barrier for killing bacteria at a localized body entry is disclosed in U.S. Pat. No. 4,569,673 to Tsai. Tsai teaches placing a strip of an oligodynamic metal on a nonconductive substrate. The oligodynamic metal acts as a sacrificial galvanic anode and gives off ions when placed in conductive contact with a dissimilar metal by placing the catheter in an electrolytic solution. Because the conductivity and pH of urine, for example, varies over time within the same person, as well as from individual to individual, it would be

extremely difficult to achieve a specific current density at a given time with any precision or predictability. Additionally, the Teal device only provides localized infection control.

Thus, none of these devices fulfill the promise held out by oligodynamic iontophoresis for reducing infection in long-term indwelling medical devices.

### SUMMARY OF THE INVENTION

The present invention provides an iontophoretic structure for a medical device that reduces the risk of infection associated with prolonged medical device implantation in the body. Specifically, the invention is directed toward meeting performance goals of general antibacterial effectiveness; minimal electrode corrosion; precise control of electrical current; portability of the current source; and ease of manufacture. These performance requirements can be readily addressed by a number of embodiments in which a controlled electrical current drives oligodynamic metal ions into solution to kill bacteria on and near the iontophoretic structure.

In one embodiment, an iontophoretic structure for a medical device includes a first and second galvanic material separated by a resistive material which when placed in contact with an electrolytic solution creates a current flow which injects anti-bacterial oligodynamic metal ions into the solution.

In another embodiment, an elastomer incorporates a first and a second galvanic material separated by resistive material which controls a current flow between the galvanic materials when the elastomer is immersed in an electrolytic fluid. The first and second galvanic materials can be metal powders in a conductive polymer that forms a composite material which may be dip-coated over an existing catheter or extruded to form the catheter itself. Alternatively, the galvanic materials can be configured in layered structures, wherein each metal layer is separated from the other by a resistive layer. The layered structures can be placed on surfaces of the catheter where antibacterial action is desired.

In another embodiment, two dissimilar metal powders embedded in a conductive polymer substrate creates an infection control sleeve that covers an ordinary catheter. When the sleeve is placed in an electrolytic fluid to complete a circuit between the metal powders, metal ions are driven into solution where they have an antibacterial effect. This embodiment is also useful as a catheter introducer sheath.

In yet another embodiment, a method is provided for giving an implantable medical device antibacterial properties by placing an iontophoretic structure on its surface prior to implantation. The iontophoretic structure can be either a coating including two dissimilar metal powders in a conductive polymer substrate, or a layered structure having two dissimilar metal layers separated by a conductive layer.

In still another embodiment, a method is provided for protecting a natural body structure with an iontophoretic structure comprising two dissimilar metal powders in a conductive base material. The iontophoretic structure is painted onto the body structure when the base material is in a softened or uncured state. The base material is then allowed to harden or cure.

### DESCRIPTION OF THE DRAWINGS

The invention will be more fully understood from the following detailed description taken in conjunction with the accompanying drawings in which:

FIG. 1 is a perspective view of an iontophoresis catheter incorporating a composite material comprising metal powders in a conductive elastomeric matrix;

FIG. 2 is a partial sectional view of the iontophoresis catheter of FIG. 1;

FIG. 3 is a depiction of the iontophoresis effect created by the composite material in the catheter of FIG. 1;

FIG. 4 is a perspective view of a pacing lead coated with the composite material of FIG. 1;

FIG. 5 is a perspective view of an artificial hip joint partially coated with the composite material of FIG. 1;

FIG. 6A is a perspective view of an infusion pump coated with the composite material of FIG. 1;

FIG. 6B is a perspective view of a tooth coated with the composite material of FIG. 1;

FIG. 7 is a perspective view of a catheter with an iontophoresis infection control sheath;

FIG. 8 is a perspective view of a catheter with an iontophoresis infection control introducer sheath;

FIG. 9 is a perspective view of an iontophoresis catheter having a plurality of layered electrodes;

FIG. 10 is a perspective view of an alternative embodiment of an iontophoresis catheter having a plurality of layered electrodes arranged in strips; and

FIG. 11 is a partial sectional view of the iontophoresis catheter of FIG. 10.

### DETAILED DESCRIPTION OF THE INVENTION

Iontophoretic structures in accordance with the invention may be divided into two categories: a composite material used to coat a medical device, or a plurality of discrete layered electrodes placed on the medical device, both of which categories are disclosed hereinbelow. The medical device can be a short-term, long-term, or permanent implant and includes such devices as: urinary catheters, vascular access catheters and introducer sheaths, fluid introduction tubing and fittings such as intravenous tubing, urinary drainage bags and tubing, chest drainage tubes, infusion pumps, pacing leads, tracheotomy tubes, ventilation tubes, prosthetic joints, heart valves, wound dressings, orthopedic pins or plates, or any other medical device used in an environment or application where anti-bacterial properties are a consideration. However, because urinary catheters are an especially attractive application for the iontophoretic structures, the ensuing detailed description is directed thereto.

With respect to the first category of iontophoretic structure for a medical device, FIG. 1 illustrates an exemplary iontophoresis catheter 10 that uses the composite material approach to kill bacteria. The iontophoresis catheter 10 is substantially identical to a normal or non-infection controlling catheter in that it is a hollow flexible tube comprising an elastomeric wall 12 having an inner surface 14 and an outer surface 16, a proximal end 18, and a distal end 20. The generally cylindrical inner surface 14 defines a lumen 22 for the passage of fluid. Both the proximal end 18 and the distal end 20 are provided with one or more openings 26 to allow the fluid to be introduced or evacuated from the lumen 22. The distal end 20 is shaped to facilitate insertion or placement of the iontophoresis catheter 10 into the body. The iontophoresis catheter 10 may also be fitted with a retention device 28, such as a balloon fitting, to prevent unintentional withdrawal of the iontophoresis catheter 10 from the body.

FIG  
catheter  
detail  
distal  
matrix  
from  
precise  
second  
base  
is statu  
ics in  
prede  
tive pr  
vinyl  
condu  
tion or  
can be  
material  
and se  
chemic  
gold, a  
polym  
sition fa  
except  
such r  
impact  
For  
is extra  
compo  
which  
not ext  
a final  
The ref  
finish  
Since  
infecti  
tagou  
Who  
or imm  
blood  
powde  
cally,  
materi  
becom  
particu  
powde  
Ref  
creat  
of FIG  
34 net  
tween  
materi  
are thu  
The el  
of met  
and b  
factor  
densit  
follow

wherei  
"r"  
"i"  
"p"  
m



FIG. 2 is a partial sectional view of the iontophoresis catheter 10 of FIG. 1, taken along the line A-A', that depicts details of a composite material comprising galvanic materials, such as metal powders, in a conductive elastomeric matrix 30 that distinguishes the iontophoresis catheter 10 from prior art catheters. The wall 12 of the catheter comprises the conductive base material 30, and a first and a second dissimilar metal powder, 32 and 34 respectively. The base material 30 is a conductive polymer similar to that used in static-proof bags for packaging charge-sensitive electronics in which the conductivity (resistivity) is controlled to a predetermined value by its composition. Exemplary conductive polymers can be made from polymers including polyvinyl, polyester, polyethylene, polyurethane, or a naturally conductive polyvinylidene fluoride. When loaded with carbon or other conductive fillers, for example, these polymers can be made conductive and thereby used as the base material 30 for an iontophoresis catheter 10. Exemplary first and second metal powder combinations having an electrochemical half-cell potential difference include silver and gold, silver and copper, or silver and platinum mixed into the polymer at very low volume concentrations prior to extrusion fabrication of the composite catheter 10. Although these exemplary powders are relatively expensive, they are used in such minute quantities that their use does not adversely impact overall cost of the iontophoresis catheter 10.

For catheter applications in which the elastomeric wall 12 is extruded, it is feasible to make the entire wall 12 from the composite material 30, 32, 34. However, Foley catheters which are typically made of latex and/or silicone rubber are not extruded, but are generally dip-cast, and finish-coating in a final dip is a natural processing step in their manufacture. Therefore, the iontophoresis catheter 10 can be made by finish-coating it with the composite material 30, 32, 34. Since rubber is generally inferior to plastic in terms of infection rates, overcoating with a castable plastic is advantageous in and of itself.

When the composite catheter 10 is placed in contact with or immersed in a fluid that is electrolytic, such as saline, blood, drug preparations, or urine, the first and second metal powders 32, 34 become an array of small batteries. Specifically, each powdered metal granule embedded in the base material 30 that makes contact with the electrolytic fluid 24 becomes either an anode or a cathode, depending on the particular metals chosen as the first and second metal powders 32, 34.

Referring to FIG. 3, a depiction of the iontophoresis effect created by the composite material 30, 32, 34 in the catheter of FIG. 2 is shown. The first and second metal powders 32, 34 act as electrodes and create a voltage potential therebetween, whereby electrons 36 migrate through the base material 30 and generate an electric current. Metal ions 38 are thus driven into the conductive fluid 24 by iontophoresis. The electric current is regulated by the quantity and nature of metal powder 32, 34 embedded in the base material 30 and by the conductivity of the base material 30. These factors are adjusted so that the current and ultimate metal ion densities are in an efficacious and safe range by use of the following formula:

$$I \left( \frac{\text{AMP}}{\text{CM}^2} \right) = \frac{V}{4\rho} \ln \left[ \frac{L-2r}{L-2r-1} \right]$$

wherein:

"I" is the total average current per unit surface area (amperes per  $\text{cm}^2$ );

" $\rho$ " is the volume resistivity of the conductive base material 30 (ohm-cm);

"r" is the average metal powder granule radius (cm);

"V" is the voltage produced by the two dissimilar metal powders 32, 34 in the electrolytic fluid; and

"L" is the metal powder volume loading of the base material as a fraction (ie 0-1).

With respect to the above formula, the metal powders are assumed to be of the same granule size and of the same volume loading. In practice, they do not have to be the same size and volume loading. To achieve a current density between  $10^{-4}$  to  $10^{-6}$  Amperes per  $\text{mm}^2$ , which is the desired range to be bacteriostatic or bactericidal and yet not be so high as to cause pH changes or other deleterious mammalian cell reactions, the following exemplary values can be used in the above equation to define the composite material specifications:

$V=0.12$  volts (for silver and gold in an NaCl electrolyte);

$r=10^{-4}$  cm;

$\rho=1.5 \times 10^{-8}$  to  $1.5 \times 10^{-4}$  ohm-cm; and

$L=0.01$ .

An iontophoresis catheter 10 incorporating the above described composite material has numerous advantages over the prior art with respect to effectiveness, controllability, and ease of use. Foremost, bacterial potency is maximized because metal is guaranteed to go into solution as ions, thus producing a minimum ten-fold reduction in bacterial colonization rate. Also, the iontophoresis catheter 10 does not need an external current source or controller because the iontophoresis current is self-generating and self-regulating. Furthermore, because the metal powders 32, 34 (electrodes) are dispersed through the base material 30, and because the current level is very low, the electrodes are functional for months of use. There is also no place in the circuit where corrosion of the electrodes at the electrolyte interface can cause the entire catheter to become non-functional with regard to its infection resistance. Finally, there is no change in procedure for placing or maintaining the iontophoresis catheter 10 because it is in many ways virtually identical to existing non-infection control devices in size and shape.

As previously discussed, the composite material approach finds ready application on numerous other medical devices where antibacterial properties are desirable. FIG. 4 is an illustration of the composite material 30, 32, 34 used to protect a pacing lead 40. The pacing lead 40 connects the heart tissue to the control and monitoring apparatus of a cardiac pacemaker (not shown) via a wire 42 and an electrode 44 in the tissue. The wire 42 is shown covered with the composite material 30, 32, 34. FIG. 5 is a depiction of the composite material 30, 32, 34 used with a prosthetic device, such as an artificial hip joint 46. The shaft 48 is shown coated with composite material 30, 32, 34 and implanted into a femur 50. FIG. 6A shows an infusion pump 52 coated with the composite material 30, 32, 34 and connected to tubing 54 which may also be coated.

The composite material 30, 32, 34 can also be coated onto a natural body structure 55, such as a tooth, as illustrated in FIG. 6B. This is accomplished by painting the composite material 30, 32, 34 onto the surface to be protected while the base material 30 is in a liquified or softened state and then letting the base material 30 harden. In an alternative embodiment the base material 30 is binary adhesive, such as a catalytic, two-part, conductive epoxy mix.

With further regard to catheters, a vascular access add-on device that benefits from the composite material approach for an iontophoresis structure is shown in FIG. 7, wherein an ordinary catheter 56 is shown fitted with an infection control kit 58 incorporating the composite material 30, 32, 34. The

infection control kit 58 is an after-market device which includes a replaceable iontophoretic infection control sleeve 60 and an iontophoretic Lucr adaptor 62 for connecting the proximal end 18 of the catheter 56 to intravenous (I.V.) tubing 64. The sleeve 60, made of or coated with the composite material 30, 32, 34 slips over the outer surface 16 of the catheter 56 to be inserted into the body. The sleeve 60 covers only a short section of the catheter 56 near its proximal end 18, but is long enough to enter the body wherein moisture will activate the iontophoresis process. The sleeve 60 thus protects the catheter surface 16 from infection. The Lucr adaptor 62 may also be made of or coated on the inner surface with the composite material 30, 32, 34 to protect the inner surface 14 of the catheter 56 from bacterial colonization progressing down to the catheter 56 from the inside of the I.V. tube 64. The sleeve 60 is fabricated from one of the above referenced conductive base materials 30; and the Lucr adaptor 62 is made of a harder plastic, such as acrylic or polycarbonate. The sleeve 60 may be configured to accommodate a variety of catheter sizes.

An adaptation of the composite material sleeve 60 can also be configured as a catheter introducer sheath 66, shown in FIG. 8, for inserting pulmonary artery (Swan-Ganz or thermodilution) catheters, temporary pacing leads, etc., which may remain in place for several weeks. Under normal circumstances, an introducer sheath is left in place with the catheter which it surrounds for a portion of its length, including the region where the device penetrates the skin. Iontophoretic introducer sheaths 66 are easily manufactured with the composite material approach because they are predominantly made of polytetrafluoroethylene (Teflon®), vinyl (PVC), or polyethylene (PE), materials which can be loaded with carbon or other conductive fillers or made conductive by other means known in the art and then loaded as well as the first and second metal powders 32, 34.

FIG. 8 shows the introducer sheath 66 used in conjunction with a thermodilution catheter 68. Balloon and temperature sensing elements, 74 and 75 respectively, known to those skilled in the art, are shown on the distal end 20. Because the inside of the introducer sheath 66 is in intimate contact with the outer surface 16 of the elastomeric wall 12, the Composite material 30, 32, 34 of the introducer sheath 66 protects both the sheath 66 and the outer wall 12 of the thermodilution catheter 68. Like the iontophoretic catheter 10, and the catheter 56 having an iontophoretic infection control kit 58, the introducer sheath 66 is virtually identical in size, shape, and use as prior art devices.

As described with respect to FIGS. 1-8, various embodiments of the composite material category of the iontophoretic structure for a medical device have been illustrated. In composite material embodiments, the integral power source for driving oligodynamic metal ions into solution is the electromotive force created by dissimilar metal powders 32, 34 embedded in and separated from each other by the conductive base material 30 of specifically created resistivity.

Referring now to FIGS. 9-11, a variety of embodiments of the other category of iontophoretic structure for a medical device are shown which incorporate the plurality of discrete layered structures. In these embodiments a plurality of layered structures comprise dissimilar galvanic materials separated by a resistive layer. These structures may be incorporated in the above-recited medical devices during manufacture, or adhered to the surface of the devices as an after-market item.

Referring to FIG. 9 a perspective view of an embodiment of an iontophoretic catheter 70 is shown, wherein the

oligodynamic iontophoresis effect is achieved using a plurality of layered structures 72 on either the inner surface 14, the outer surface 16, or both of a non-conductive wall 12. The layered structures 72, while depicted in a circular configuration can be any shape, such as oval or square.

FIG. 10 depicts an alternative configuration of the iontophoretic catheter 70, wherein the plurality of layered structures 72 are bands that surround the wall 12. Alternatively, the layered structures 72 can be a plurality of longitudinal strips. The embodiments of FIGS. 9 and 10 permit selective placement of a layered structure 72 on an isolated region of the wall 12, or distribution of the layered structures 72 on the entire wall 12.

Referring to FIG. 11, a partial cross section of the iontophoretic catheter 70 of FIG. 10 along the line B-B' is shown, wherein the layered structures 72 are bands adhered to the inner surface 14 and outer surface 16 of the wall 12. Each layered electrode 72 comprises a first metal electrode 76, a resistive layer 78, and a second metal electrode 80. As with the iontophoretic catheter 10 of FIG. 1, the metals are biocompatible and form an electrical potential difference between them in an electrolytic fluid. Whereas, in the iontophoretic catheter 10 of FIG. 1 the conductive (resistive) base material 30 regulates the current flow between the first and second metals 32, 34, in this embodiment the (conductive) resistive layer 78 regulates the current flow between the dissimilar metals of the first and second electrodes 76, 80.

For the iontophoretic catheter 70 of FIGS. 9 and 10, wherein the first and second metal electrodes 76, 80 of the layered structures 72 have a 1 volt potential between them, a current density of  $10^{-2}$  Amperes per  $\text{mm}^2$  results if the thickness of the resistive layer 78 is approximately 10 micrometers and has a bulk conductivity of  $10^{11}$  Ohm-cm and the exposed area of each of the electrodes 76, 80 in the layered structures 72 is the same. Typical combinations of metals used for the first and second metal electrodes 76, 80 generate between 0.1 to 2 Volts. Therefore, the thickness of the above described resistive layer 78 can be between 1 and 20 micrometers. Many other combinations of conductivity and thickness for the resistive layer 78 are possible to obtain the target current density.

Although the invention has been shown and described with respect to exemplary embodiments thereof, various other changes, omissions and additions in form and detail thereof may be made therein without departing from the spirit and scope of the invention.

I claim:

1. An iontophoretic structure comprising:

a first material having a first galvanic electrical potential;

a second material having a second galvanic electrical potential and a conductive polymer separating said first material from said second material, said conductive polymer having a predetermined resistivity and controlling a current flow produced between said first material and said second material when said iontophoretic structure is in contact with an electrolytic fluid.

2. The iontophoretic structure of claim 1, wherein said first material comprises silver and said second material comprises gold.

3. The iontophoretic structure of claim 1, wherein said first material comprises silver and said second material comprises platinum.

4. The iontophoretic structure of claim 1, wherein said first material comprises silver and said second material comprises copper.

5. The iontophoretic structure of claim 1, wherein said conductive polymer is chosen from the group consisting of

polyvinyl, polyester, polyethylene, polyurethane, and polyvinylidene.

6. The iontophoretic structure of claim 1, wherein said first material includes a first metal powder and said second material includes a second metal powder, said first and said second metal powders embedded in said conductive polymer.

7. An iontophoresis catheter comprising:

an elastomeric cylindrical wall having an outer wall surface and an inner wall surface, said inner wall surface defining a lumen for containing a fluid, and a distal end and a proximal end, each said end having at least one opening to permit introduction or evacuation of said fluid from said lumen, said wall comprising a first material having a first galvanic electrical potential and a second material having a second galvanic electrical potential, said first and second materials separated by a conductive polymer having a predetermined resistivity for controlling a current flow produced when said iontophoresis catheter is in contact with an electrolytic fluid.

8. The iontophoresis catheter of claim 7, wherein said first material comprises silver and said second material comprises gold.

9. The iontophoresis catheter of claim 7, wherein said first material comprises silver and said second material comprises platinum.

10. The iontophoresis catheter of claim 7, wherein said first material comprises silver and said second material comprises copper.

11. The iontophoresis catheter of claim 7, wherein said conductive polymer is chosen from the group consisting of polyvinyl, polyurethane, polyester, polyethylene, and polyvinylidene.

12. The iontophoresis catheter of claim 7, wherein said first material comprises a first metal powder, said second material comprises a second metal powder, and said wall comprises said conductive polymer, said first and said second metal powder embedded in said conductive polymer, wherein said conductive polymer controls a current flow produced between said first metal powder and said second metal powder.

13. The iontophoresis catheter of claim 12, wherein said first and second metal powder, and said conductive polymer comprise a composite material extruded to form at least part of said cylindrical elastomeric wall.

14. The iontophoresis catheter of claim 12, wherein said first and second metal powder, and said conductive polymer comprise a liquified composite material into which said cylindrical elastomeric wall is dipped to form a composite coating.

15. An iontophoresis catheter comprising:

an elastomeric cylindrical wall having an outer wall surface and an inner wall surface, said inner wall surface defining a lumen for containing a fluid, and a distal end and a proximal end, each said end having at least one opening to permit introduction or evacuation of said fluid from said lumen, said elastomeric cylindrical wall comprising a first metal powder and a second metal powder embedded in a conductive polymer having a predetermined resistivity for controlling a current flow produced between said first and second metal powder when said iontophoresis catheter is in contact with an electrolytic fluid.

\* \* \* \* \*

a plu-  
e 14,  
1 12.  
areular  
quare.  
he ionto-  
ed struc-  
matively,  
itudinal  
selective  
region of  
72 on the  
  
he ionto-  
s shown,  
ed to the  
12. Each  
ode 76, a  
1. As with  
metals are  
differences  
s, in the  
(resistive)  
s the first  
(conduc-  
etween the  
s. 76, 80,  
7 and 10,  
80 of the  
cen them,  
ults if the  
nately 10  
Ohs-on  
00 in the  
ns of  
6. 80  
-kness of  
1) and  
-nctivity  
e to obtain  
  
described  
of, various  
and detail  
from the  
  
potential;  
- electrical  
g said first  
conductive  
and con-  
said first  
aid ionto-  
electrolytic  
  
wherein said  
d material  
  
wherein said  
d material  
  
wherein said  
d material  
  
said  
ng of



United States Patent [19]  
Milder



US005322520A

[11] Patent Number: 5,322,520  
[45] Date of Patent: Jun. 21, 1994

- [54] IONTOPHORETIC STRUCTURE FOR MEDICAL DEVICES  
[75] Inventor: Fredric L. Milder, Brookline, Mass.  
[73] Assignee: Implemed, Inc., Brookline, Mass.  
[21] Appl. No.: 975,597  
[22] Filed: Nov. 12, 1992  
[51] Int. Cl.<sup>3</sup> A61M 5/32  
[52] U.S. Cl. 604/265; 604/20; 604/21  
[58] Field of Search 604/265, 280, 20, 21, 604/8, 266, 27, 173; 128/389, 391, 786, 783, 642; 607/149, 152, 153, 122

[56] References Cited  
U.S. PATENT DOCUMENTS

1,964,477	6/1976	Ellis et al.	604/20
4,027,393	6/1977	Ellis et al.	433/173
4,054,139	10/1977	Crossley	604/265
4,126,937	11/1978	Ellis et al.	433/228.1
4,304,859	1/1982	Child	604/24
4,313,438	2/1982	Greatbatch	604/20
4,411,648	10/1983	Davis et al.	604/21
4,474,570	10/1984	Artura et al.	604/20
4,476,590	10/1984	Scales et al.	623/18
4,483,688	11/1984	Akiyama	604/265
4,564,361	1/1986	Akiyama	604/265
4,569,673	2/1986	Tesi	604/20
4,603,152	7/1986	Laurin et al.	604/265
4,886,075	12/1989	Jones	128/787
4,886,505	12/1989	Haynes et al.	604/265
5,049,140	9/1991	Brenner et al.	604/266

FOREIGN PATENT DOCUMENTS

0306024	12/1986	European Pat. Off.	604/265
9116946	11/1991	European Pat. Off.	
3830359	12/1989	Fed. Rep. of Germany	
1582016	12/1980	United Kingdom	

OTHER PUBLICATIONS

J. A. Spadaro et al., Antibacterial Effects of Silver

Electrodes with Weak Direct Current, Antimicrobial Agents and Chemotherapy, vol. 6, No. 5, Nov., 1974, pp. 637-642.

C. P. Davis et al., Electrode and Bacterial Survival With Iontophoresis In Synthetic Urine, The Journal of Urology, vol. 147, May, 1992, pp. 1310-1313.

Primary Examiner—John D. Yasko  
Assistant Examiner—Vanitha Alexander  
Attorney, Agent, or Firm—Weingarten, Schurgin, Gagnon & Hayes

[57] ABSTRACT

An iontophoretic structure for medical devices is provided that uses controlled electrical current derived from two dissimilar galvanic materials to drive oligodynamic metal ions into solution to kill bacteria on and near the device to which the structure is affixed. In one embodiment, a first galvanic material separated from a second galvanic material by a resistive material produces an anti-bacterial current flow when placed in contact with an electrolytic fluid. In another embodiment, a cylindrical elastomeric catheter incorporates a first and a second galvanic material separated by a resistive material which controls a current flow between the galvanic materials when the catheter is immersed in an electrolytic fluid. The galvanic materials can be dissimilar metal powders embedded in a conductive polymer substrate that forms an iontophoretic composite material, or dissimilar metals arranged in layers separated by a resistive layer. In yet another embodiment, the iontophoretic composite material is configured as an infection control sleeve that covers a portion of an ordinary catheter or cannula. Methods of protecting implantable medical devices and body structures with the iontophoretic structures are also provided.

7 Claims, 3 Drawing Sheets

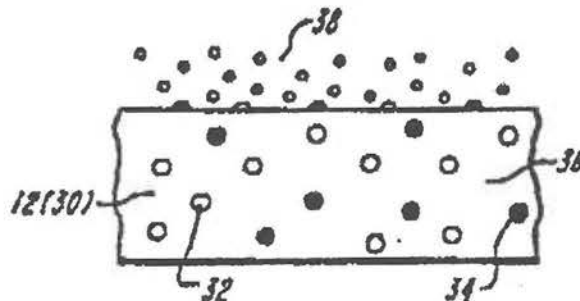

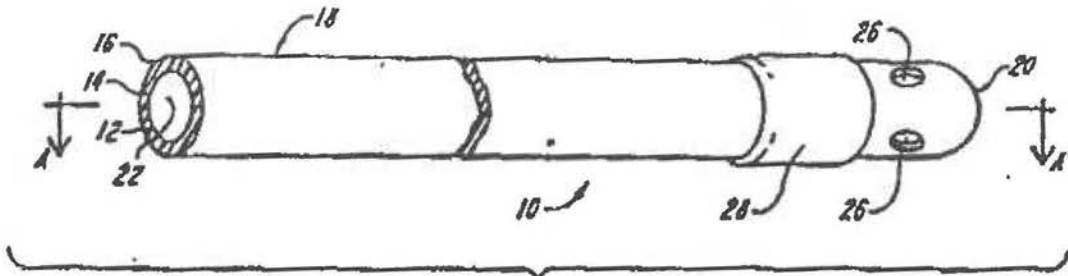

FIG. 1

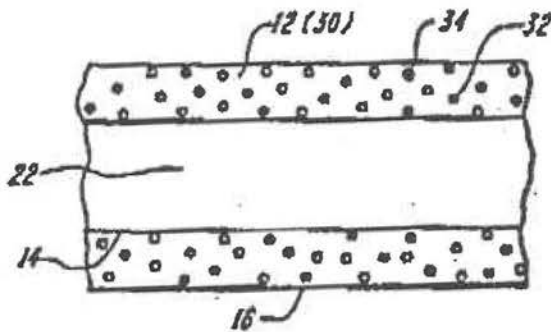

FIG. 2

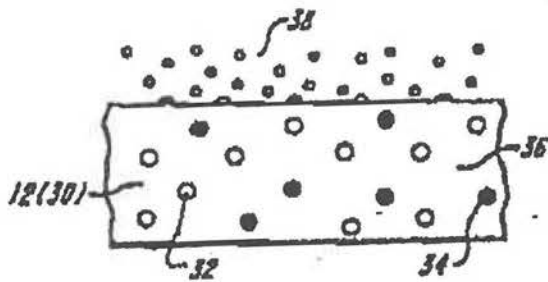

FIG. 3

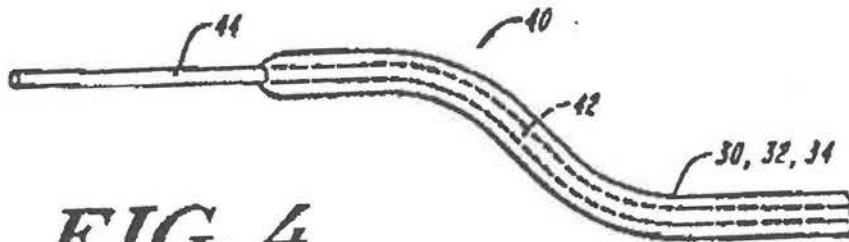
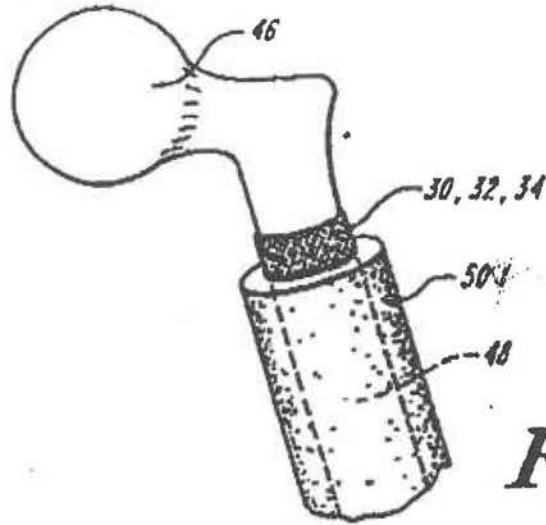
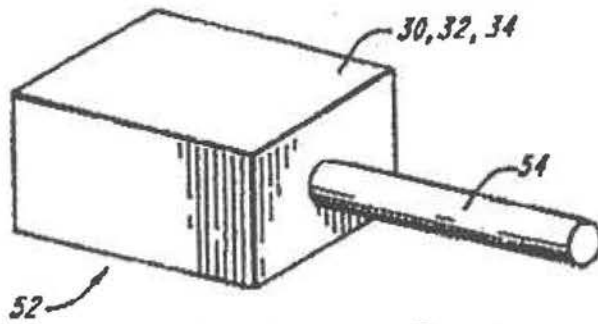

FIG. 4



**FIG. 5**



**FIG. 6A**

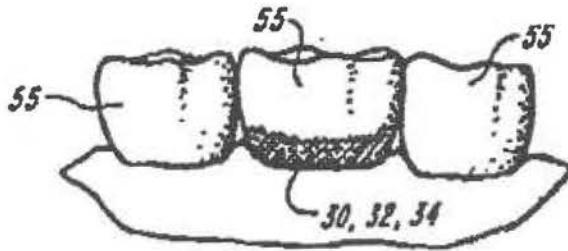

**FIG. 6B**

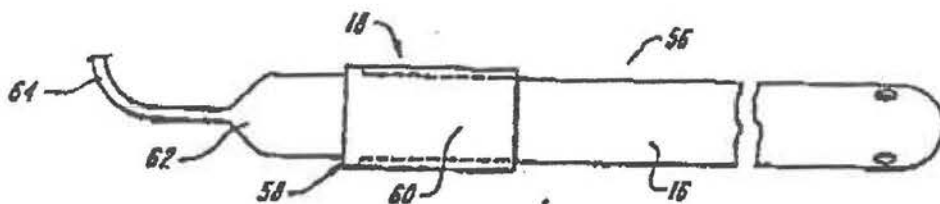

FIG. 7

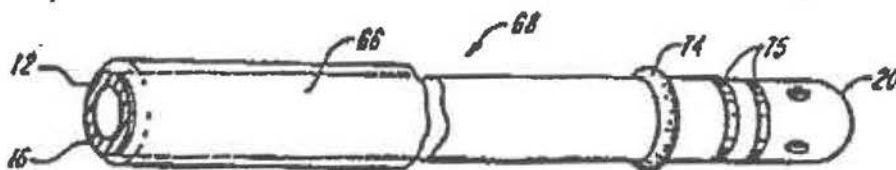

FIG. 8

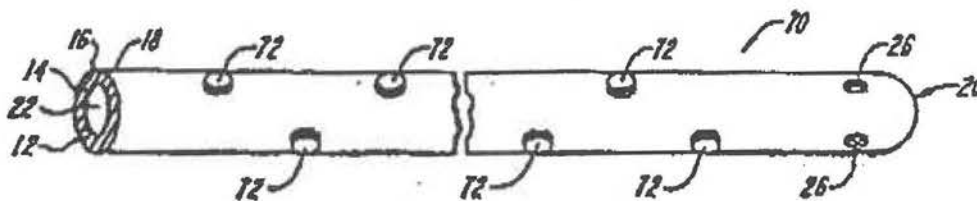

FIG. 9

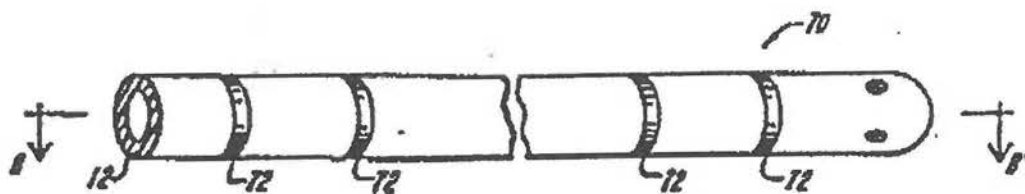

FIG. 10

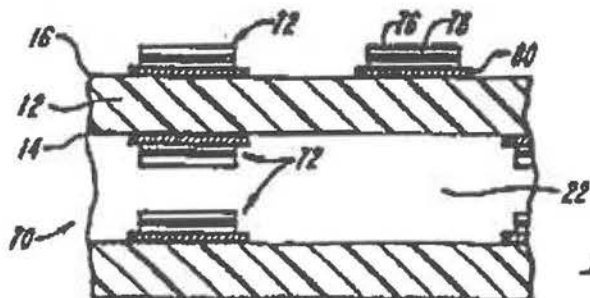

FIG. 11

## IONTOPHORETIC STRUCTURE FOR MEDICAL DEVICES

### FIELD OF THE INVENTION

The invention relates to oligodynamic iontophoresis, and more particularly to an electrically conductive structure for medical devices that reduces or eliminates bacterial infection by killing bacteria with controlled oligodynamic iontophoresis.

### BACKGROUND OF THE INVENTION

Oligodynamic metals, such as silver, are effective in minute quantities as bacteriostats and bactericides. The most active form of these oligodynamic metals is as ions in solution. While the precise nature of the bactericidal effect is unknown, it is believed to involve altering the function of the cell membrane or linking to the cell's DNA to disrupt cell function. The bactericidal action is effective against a broad spectrum of bacteria, including all of the common strains which cause infection. When these metals are used in the minute concentrations required to kill or stem the growth of bacteria, they do not have any detrimental effect on normal mammalian cells.

Silver is used routinely in antibacterial salves, such as silver sulfadiazine, and has also been used in clinical trials to coat gauze for burn dressings. Medical devices, such as catheters, with silver impregnated in a soluble collagen or polymer coating are also known. After these catheters are placed, the coating slowly dissolves and the silver is released over time into the environment. The infection rates with these products are reported to be two to four times lower than standard catheters.

One catheter that uses silver as an antibacterial agent has had only limited success because the device, consisting of a silver impregnated collagen cuff which is inserted just below the skin, is difficult to place correctly. The cuff is also expensive, increasing the cost of a central venous catheter almost three-fold. Other catheters for reducing infection rates use well known approaches, most of them varying only in the type and solubility of the silver or silver-alloy coating.

Many of the prior art catheters that use oligodynamic metals as bacteriostats fail to adequately prevent infection for one or more of the following reasons: 1) Silver released from soluble coatings is not always in the same charge state and often is not charged at all, therefore its bactericidal potential is not optimized; 2) With soluble-coated catheters, once the coating dissolves, usually over about two weeks there is no further antibacterial protection; 3) A non-soluble silver, silver alloy or silver-oxide coating can prevent colonization of the catheter to a limited extent, but the oligodynamic metal is not released into the surrounding fluid or tissue; 4) Due to the substantial change in the catheter placement procedure, the use of these catheters requires additional personnel training; and 5) Although infection can enter the body through either the interior or the exterior of the catheter, not all catheters provide both interior and exterior protection. Furthermore, despite the capability of silver-alloy coated devices to produce a two to four fold reduction in bacterial colonization, their high cost greatly detracts from their modest capabilities.

Research from the 1970's onward has been directed toward improving the antibacterial effects of oligodynamic metals by electrically injecting the metal ions into

solution. This process, known as oligodynamic iontophoresis, is capable of reducing bacterial colonization fifteen to one-hundred fold. Iontophoresis describes the movement of ions in a conductive fluid under the influence of low-strength electric fields, and in this context refers to the forcing of ions into a conductive fluid environment using minute electric currents. For example, if two electrodes made of a metal, such as silver, are introduced into a conductive medium, such as saline, blood or urine, and an electrical potential is applied across the electrodes, silver ions are driven into solution creating an enhanced bactericidal effect. The current required to safely drive a sufficient amount of silver ions into solution to control infection is in the range of 1 to 400 microAmperes. This current range does not cause localized cell necrosis and it is below the sensory or pain threshold.

Despite its great potential, the oligodynamic iontophoresis phenomenon has found limited use in conjunction with medical devices, although urological or Foley catheters have progressed to animal experiments. With respect to Foley catheters, researchers have identified several deficiencies in prior art devices. Foremost is that the electrodes used to force ions into solution wear out, or corrode, at the interface between air and the conductive medium. This problem probably also arises in blood or saline environments as well as urine. Other significant drawbacks with prior art iontophoretic devices include bulky, current-controlled power sources required for driving the electrodes; electrode configurations that do not protect both the outside and the inside of the catheter; and manufacturing processes that are labor intensive.

An example of an infection control catheter that uses separate electrodes on the catheter and an external power supply to drive ions into solution is U.S. Pat. No. 4,411,648 to Davis. Other prior art oligodynamic iontophoresis devices do not use external power supplies. For example, U.S. Pat. No. 4,886,505 to Haynes teaches placing two metals in direct physical contact to produce electrical currents. The currents produced, however, are likely to be too large to be safely used and possibly will alter the pH of the environment. In German Patent Document DE 3,830,359, two dissimilar metal powders not in electrical contact with each other are embedded in a nonconductive catheter material, such as electrically insulating polymers. Because of the separation of dissimilar metals by an insulator, it is not likely that there is any iontophoresis effect in this device as a result of a potential being created by the dissimilar metals, except for the possibility of when a biofilm forms on the catheter surface to complete the circuit. Were an electrical circuit to be formed in this manner, the current density would not be regulated or predictable, and the current produced therefore could be either too high to be safe or too low to be effective.

An oligodynamic iontophoresis catheter which uses the properties of metals to generate a current and to form an ion barrier for killing bacteria at a localized body entry is disclosed in U.S. Pat. No. 4,569,673 to Teel. Teel teaches placing a strip of an oligodynamic metal on a nonconductive substrate. The oligodynamic metal acts as a sacrificial galvanic anode and gives off ions when placed in conductive contact with a dissimilar metal by placing the catheter in an electrolytic solution. Because the conductivity and pH of urine, for example, varies over time within the same person, as



well as from individual to individual, it would be extremely difficult to achieve a specific current density at a given time with any precision or predictability. Additionally, the Tesi device only provides localized infection control.

Thus none of these devices fulfill the promise held out by oligodynamic iontophoresis for reducing infection in long-term indwelling medical devices.

#### SUMMARY OF THE INVENTION

The present invention provides an iontophoretic structure for a medical device that reduces the risk of infection associated with prolonged medical device implantation in the body. Specifically, the invention is directed toward meeting performance goals of general antibacterial effectiveness; minimal electrode corrosion; precise control of electrical current; portability of the current source; and ease of manufacture. These performance requirements can be readily addressed by a number of embodiments in which a controlled electrical current drives oligodynamic metal ions into solution to kill bacteria on and near the iontophoretic structure.

In one embodiment, an iontophoretic structure for a medical device includes a first and second galvanic material separated by a resistive material, which when placed in contact with an electrolytic solution creates a current flow which injects anti-bacterial oligodynamic metal ions into the solution.

In another embodiment, an elastomer incorporates a first and a second galvanic material separated by resistive material which controls a current flow between the galvanic materials when the elastomer is immersed in an electrolytic fluid. The first and second galvanic materials can be metal powders in a conductive polymer that forms a composite material which may be dip-coated over an existing catheter or extruded to form the catheter itself. Alternatively, the galvanic materials can be configured in layered structures, wherein each metal layer is separated from the other by a resistive layer. The layered structures can be placed on surfaces of the catheter where antibacterial action is desired.

In another embodiment, two dissimilar metal powders embedded in a conductive polymer substrate create an infection control sleeve that covers an ordinary catheter. When the sleeve is placed in an electrolytic fluid to complete a circuit between the metal powders, metal ions are driven into solution where they have an antibacterial effect. This embodiment is also useful as a catheter introducer sheath.

In yet another embodiment, a method is provided for giving an implantable medical device antibacterial properties by placing an iontophoretic structure on its surface prior to implantation. The iontophoretic structure can be either a coating including two dissimilar metal powders in a conductive polymer substrate, or a layered structure having two dissimilar metal layers separated by a conductive layer.

In still another embodiment, a method is provided for protecting a natural body structure with an iontophoretic structure comprising two dissimilar metal powders in a conductive base material. The iontophoretic structure is painted onto the body structure when the base material is in a softened or uncured state. The base material is then allowed to harden or cure.

#### DESCRIPTION OF THE DRAWINGS

The invention will be more fully understood from the following detailed description taken in conjunction with the accompanying drawings in which:

FIG. 1 is a perspective view of an iontophoresis catheter incorporating a composite material comprising metal powders in a conductive elastomeric matrix;

FIG. 2 is a partial sectional view of the iontophoresis catheter of FIG. 1;

FIG. 3 is a depiction of the iontophoresis effect created by the composite material in the catheter of FIG. 1;

FIG. 4 is a perspective view of a pacing lead coated with the composite material of FIG. 1;

FIG. 5 is a perspective view of an artificial hip joint partially coated with the composite material of FIG. 1;

FIG. 6A is a perspective view of an infusion pump coated with the composite material of FIG. 1;

FIG. 6B is a perspective view of a tooth coated with the composite material of FIG. 1;

FIG. 7 is a perspective view of a catheter with an iontophoresis infection control sheath;

FIG. 8 is a perspective view of a catheter with an iontophoresis infection control introducer sheath;

FIG. 9 is a perspective view of an iontophoresis catheter having a plurality of layered electrodes;

FIG. 10 is a perspective view of an alternative embodiment of an iontophoresis catheter having a plurality of layered electrodes arranged in strips; and

FIG. 11 is a partial sectional view of the iontophoresis catheter of FIG. 10.

#### DETAILED DESCRIPTION OF THE INVENTION

Iontophoretic structures in accordance with the invention may be divided into two categories: a composite material used to coat a medical device, or a plurality of discrete layered electrodes placed on the medical device, both of which categories are disclosed hereinbelow. The medical device can be a short-term, long-term, or permanent implant and includes such devices as: urinary catheters, vascular access catheters and introducer sheaths, fluid introduction tubing and fittings such as intravenous tubing, urinary drainage bags and tubing, chest drainage tubes, infusion pumps, pacing leads, tracheotomy tubes, ventilation tubes, prosthetic joints, heart valves, wound dressings, orthopedic pins or plates, or any other medical device used in an environment or application where anti-bacterial properties are a consideration. However, because urinary catheters are an especially attractive application for the iontophoretic structures, the ensuing detailed description is directed thereto.

With respect to the first category of iontophoretic structure for a medical device, FIG. 1 illustrates an exemplary iontophoresis catheter 10 that uses the composite material approach to kill bacteria. The iontophoresis catheter 10 is substantially identical to a normal or non-infection controlling catheter in that it is a hollow flexible tube comprising an elastomeric wall 12 having an inner surface 14 and an outer surface 16, a proximal end 18, and a distal end 20. The generally cylindrical inner surface 14 defines a lumen 22 for the passage of fluid. Both the proximal end 18 and the distal end 20 are provided with one or more openings 26 to allow the fluid to be introduced or evacuated from the lumen 22. The distal end 20 is shaped to facilitate insertion or placement of the iontophoresis catheter 10 into the

body. The iontophoresis catheter 10 may also be fitted with a retention device 28, such as a balloon fitting, to prevent unintentional withdrawal of the iontophoresis catheter 10 from the body.

FIG. 2 is a partial sectional view of the iontophoresis catheter 10 of FIG. 1, taken along the line A-A', that depicts details of a composite material comprising galvanic materials, such as metal powders, in a conductive elastomeric matrix 30 that distinguishes the iontophoresis catheter 10 from prior art catheters. The wall 12 of the catheter comprises the conductive base material 30, and a first and a second dissimilar metal powder, 32 and 34 respectively. The base material 30 is a conductive polymer similar to that used in static-proof bags for packaging charge-sensitive electronics in which the conductivity (resistivity) is controlled to a predetermined value by its composition. Exemplary conductive polymers can be made from polymers including polyvinyl, polyester, polyethylene, or a naturally conductive polyvinylidene fluoride. When loaded with carbon or other conductive fillers, for example, these polymers can be made conductive and thereby used as the base material 30 for an iontophoresis catheter 10. Exemplary first and second metal powder combinations having an electrochemical half-cell potential difference include silver and gold, silver and copper, or silver and platinum mixed into the polymer at very low volume concentrations prior to extrusion fabrication of the composite catheter 10. Although these exemplary powders are relatively expensive, they are used in such minute quantities that their use does not adversely impact overall cost of the iontophoresis catheter 10.

For catheter applications in which the elastomeric wall 12 is extruded, it is feasible to make the entire wall 12 from the composite material 30, 32, 34. However, Foley catheters which are typically made of latex and/or silicone rubber are not extruded, but are generally dip-cast, and finish-coating in a final dip is a natural processing step in their manufacture. Therefore, the iontophoresis catheter 10 can be made by finish-coating it with the composite material 30, 32, 34. Since rubber is generally inferior to plastic in terms of infection rates, overcoating with a castable plastic is advantageous in and of itself.

When the composite catheter 10 is placed in contact with or immersed in a fluid that is electrolytic, such as saline, blood, drug preparations, or urine, the first and second metal powders 32, 34 become an array of small batteries. Specifically, each powdered metal granule embedded in the base material 30 that makes contact with the electrolytic fluid 24 becomes either an anode or a cathode, depending on the particular metals chosen as the first and second metal powders 32, 34.

Referring to FIG. 3, a depiction of the iontophoresis effect created by the composite material 30, 32, 34 in the catheter of FIG. 2 is shown. The first and second metal powders 32, 34 act as electrodes and create a voltage potential therebetween, whereby electrons 36 migrate through the base material 30 and generate an electric current. Metal ions 38 are thus driven into the conductive fluid 24 by iontophoresis. The electric current is regulated by the quantity and nature of metal powder 32, 34 embedded in the base material 30 and by the conductivity of the base material 30. These factors are adjusted so that the current and ultimate metal ion densities are in an efficacious and safe range by use of the following formula:

$$I \left( \frac{\text{AMP}}{\text{CM}^2} \right) = \frac{V}{4\pi r} \ln \left[ \frac{L - 2r}{L - 2Lr - 1} \right]$$

wherein:

"I" is the total average current per unit surface area (amperes per cm<sup>2</sup>);

"ρ" is the volume resistivity of the conductive base material 30 (ohm-cm);

"r" is the average metal powder granule radius (cm);

"V" is the voltage produced by the two dissimilar metal powders 32, 34 in the electrolytic fluid; and

"L" is the metal powder volume loading of the base material as a fraction (ie 0-1).

With respect to the above formula, the metal powders are assumed to be of the same granule size and of the same volume loading. In practice, they do not have to be the same size and volume loading. To achieve a current density between 10<sup>-6</sup> to 10<sup>-4</sup> Amperes per mm<sup>2</sup>, which is the desired range to be bacteriostatic or bactericidal and yet not be so high as to cause pH changes or other deleterious mammalian cell reactions, the following exemplary values can be used in the above equation to define the composite material specifications:

V=0.12 volts (for silver and gold in an NaCl electrolyte);

r=10<sup>-3</sup>cm;

ρ=1.5×10<sup>6</sup> to 1.5×10<sup>4</sup> ohm-cm; and

L=0.01.

An iontophoresis catheter 10 incorporating the above described composite material has numerous advantages over the prior art with respect to effectiveness, controllability, and ease of use. Foremost, bacterial potency is maximized because metal is guaranteed to go into solution as ions, thus producing a minimum ten-fold reduction in bacterial colonization rate. Also, the iontophoresis catheter 10 does not need an external current source or controller because the iontophoresis current is self-generating and self-regulating. Furthermore, because the metal powders 32, 34 (electrodes) are dispersed through the base material 30, and because the current level is very low, the electrodes are functional for months of use. There is also no place in the circuit where corrosion of the electrodes at the air/electrolyte interface can cause the entire catheter to become non-functional with regard to its infection resistance. Finally, there is no change in procedure for placing or maintaining the iontophoresis catheter 10 because it is in many ways virtually identical to existing non-infection control devices in size and shape.

As previously discussed, the composite material approach finds ready application on numerous other medical devices where antimicrobial properties are desirable. FIG. 4 is an illustration of the composite material 30, 32, 34 used to protect a pacing lead 40. The pacing lead 40 connects the heart tissue to the control and monitoring apparatus of a cardiac pacemaker (not shown) via a wire 42 and an electrode 44 in the tissue. The wire 42 is shown covered with the composite material 30, 32, 34. FIG. 5 is a depiction of the composite material 30, 32, 34 used with a prosthetic device, such as an artificial hip joint 46. The shaft 48 is shown coated with composite material 30, 32, 34 and implanted into a femur 50. FIG. 6A shows an infusion pump 52 coated with the composite material 30, 32, 34 and connected to tubing 54 which may also be coated.

The composite material 30, 32, 34 can also be coated onto a natural body structure 55, such as a tooth, as illustrated in FIG. 6B. This is accomplished by painting the composite material 30, 32, 34 onto the surface to be protected while the base material 30 is in a liquified or softened state and then letting the base material 30 harden. In an alternative embodiment the base material 30 is binary adhesive, such as a catalytic, two-part, conductive epoxy mix.

With further regard to catheters, a vascular access add-on device that benefits from the composite material approach for an iontophoretic structure is shown in FIG. 7, wherein an ordinary catheter 56 is shown fitted with an infection control kit 58 incorporating the composite material 30, 32, 34. The infection control kit 58 is an after-market device which includes a replaceable iontophoretic infection control sleeve 60 and an iontophoretic Luer adaptor 62 for connecting the proximal end 18 of the catheter 56 to intravenous (I.V.) tubing 64. The sleeve 60, made of or coated with the composite material 30, 32, 34 slips over the outer surface 16 of the catheter 56 to be inserted the body. The sleeve 60 covers only a short section of the catheter 56 near its proximal end 18, but is long enough to enter the body wherein moisture will activate the iontophoresis process. The sleeve 60 thus protects the catheter surface 16 from infection. The Luer adaptor 62 may also be made of or coated on the inner surface with the composite material 30, 32, 34 to protect the inner surface 14 of the catheter 56 from bacterial colonization progressing down to the catheter 56 from the inside of the I.V. tube 64. The sleeve 60 is fabricated from one of the above referenced conductive base materials 30; and the Luer adaptor 62 is made of a harder plastic, such as acrylic or polycarbonate. The sleeve 60 may be configured to accommodate a variety of catheter sizes.

An adaptation of the composite material sleeve 60 can also be configured as a catheter introducer sheath 66, shown in FIG. 8, for inserting pulmonary artery (Swan-Ganz or thermodilution) catheters, temporary pacing leads, etc., which may remain in place for several weeks. Under normal circumstances, an introducer sheath is left in place with the catheter which it surrounds for a portion of its length, including the region where the device penetrates the skin. Iontophoretic introducer sheaths 66 are easily manufactured with the composite material approach because they are predominantly made of polytetrafluorethylene (Teflon®), vinyl (PVC), or polyethylene (PE), materials which can be loaded with carbon or other conductive fillers or made conductive by other means known in the art and then loaded as well as the first and second metal powders 32, 34.

FIG. 8 shows the introducer sheath 66 used in conjunction with a thermodilution catheter 68. Balloon and temperature sensing elements, 74 and 75 respectively, known to those skilled in the art, are shown on the distal end 20. Because the inside of the introducer sheath 66 is in intimate contact with the outer surface 16 of the elastomeric wall 12, the composite material 30, 32, 34 of the introducer sheath 66 protects both the sheath 66 and the outer wall 12 of the thermodilution catheter 68. Like the iontophoresis catheter 10, and the catheter 56 having an iontophoresis infection control kit 58, the introducer sheath 66 is virtually identical in size, shape, and use as prior art devices.

As described with respect to FIGS. 1-8, various embodiments of the composite material category of the

iontophoretic structure for a medical device have been illustrated. In composite material embodiments, the integral power source for driving oligodynamic metal ions into solution is the electromotive force created by dissimilar metal powders 32, 34 embedded in and separated from each other by the conductive base material 30 of specifically created resistivity.

Referring now to FIGS. 9-11, a variety of embodiments of the other category of iontophoretic structure for a medical device are shown which incorporate the plurality of discrete layered structures. In these embodiments a plurality of layered structures comprise dissimilar galvanic materials separated by a resistive layer. These structures may be incorporated in the above-referenced medical devices during manufacture, or adhered to the surface of the devices as a after-market item.

Referring to FIG. 9 a perspective view of an embodiment of an iontophoresis catheter 70 is shown, wherein the oligodynamic iontophoresis effect is achieved using a plurality of layered structures 72 on either the inner surface 14, the outer surface 16, or both of a non-conductive wall 12. The layered structures 72, while depicted in a circular configuration can be any shape, such as oval or square.

FIG. 10 depicts an alternative configuration of the iontophoresis catheter 70, wherein the plurality of layered structures 72 are bands that surround the wall 12. Alternatively, the layered structures 72 can be a plurality of longitudinal strips. The embodiments of FIGS. 9 and 10 permit selective placement of a layered structure 72 on an isolated region of the wall 12, or distribution of the layered structures 72 on the entire wall 12.

Referring to FIG. 11, a partial cross section of the iontophoresis catheter 70 of FIG. 10 along the line B-B' is shown, wherein the layered structures 72 are bands adhered to the inner surface 14 and outer surface 16 of the wall 12. Each layered electrode 72 comprises a first metal electrode 76, a resistive layer 78, and a second metal electrode 80. As with the iontophoresis catheter 10 of FIG. 1, the metals are biocompatible and form an electrical potential difference between them in an electrolytic fluid. Whereas, in the iontophoresis catheter 10 of FIG. 1 the conductive (resistive) base material 30 regulates the current flow between the first and second metals 32, 34, in this embodiment the (conductive) resistive layer 78 regulates the current flow between the dissimilar metals of the first and second electrodes 76, 80.

For the iontophoresis catheter 70 of FIGS. 9 and 10, wherein the first and second metal electrodes 76, 80 of the layered structures 72 have a 1 volt potential between them, a current density of  $10^{-4}$  Amperes per  $\text{cm}^2$  results if the thickness of the resistive layer 78 is approximately 10 micrometers and has a bulk conductivity of  $10^{11}$  Ohm-cm and the exposed area of each of the electrodes 76, 80 in the layered structures 72 is the same. Typical combinations of metals used for the first and second metal electrodes 76, 80 generate between 0.1 to 2 Volts. Therefore, the thickness of the above described resistive layer 78 can be between 1 and 20 micrometers. Many other combinations of conductivity and thickness for the resistive layer 78 are possible to obtain the target current density.

Although the invention has been shown and described with respect to exemplary embodiments thereof, various other changes, omissions and additions in form and detail thereof may be made therein without departing from the spirit and scope of the invention.



I claim:

1. A method of providing antibacterial protection for an implantable medical device comprising:
  - selecting a medical device having a surface that is exposed to bodily fluids when said medical device is implanted within a body;
  - placing an iontophoretic structure on at least a portion of said surface, said iontophoretic structure including,
    - a first plurality of metal particles having a first galvanic electrical potential,
    - a second plurality of metal particles having a second galvanic electrical potential, and
    - a non-conductive polymer loaded with a conductive material separating said first plurality of metal particles from said second plurality of metal particles, said conductive material providing said non-conductive polymer with a predetermined resistivity for controlling a current flow produced between said first plurality of metal particles and said second plurality of metal particles when said iontophoretic structure is in contact with an electrolytic fluid; and
  - implanting said medical device within said body.
2. A method of providing antibacterial protection for an implantable medical device comprising:
  - selecting a medical device having a surface that is exposed to bodily fluids when said medical device is implanted within a body;
  - placing an iontophoretic structure on at least a portion of said surface, said iontophoretic structure including,
    - a first metal layer having a first galvanic electrical potential,
    - a second metal layer having a second galvanic electrical potential, and
    - a non-conductive polymer loaded with a conductive material separating said first metal layer from said second metal layer, said conductive material providing said non-conductive polymer with a predetermined resistivity for controlling a current flow produced between said first metal layer and said second metal layer when said iontophoretic structure is in contact with an electrolytic fluid; and
  - implanting said medical device within said body.
3. A method of protecting a natural body structure with an iontophoretic structure including a first galvanic material having a first electrical potential, a second galvanic material having a second electrical potential, and a non-conductive polymer loaded with a conductive material separating said first galvanic material from said second galvanic material, said conductive material providing said non-conductive polymer with a predetermined resistivity for controlling a current flow produced between said first galvanic material and said second galvanic material when said iontophoretic structure is in contact with an electrolytic fluid, said first

10

- galvanic material including a first plurality of metal particles, said second galvanic material including a second plurality of metal particles, said first and said second plurality of metal particles embedded in said non-conductive polymer loaded with said conductive material, comprising the steps of:
  - applying said iontophoretic structure in a pre-cured state to said natural body structure; and
  - allowing said iontophoretic structure to cure.
4. The method of claim 3, wherein said non-conductive polymer loaded with a conductive material includes a binary adhesive.
5. The method of claim 3, wherein said body structure is a tooth.
6. A method of providing antibacterial protection for an implantable medical device comprising:
  - selecting a medical device having a surface that is exposed to bodily fluids when said medical device is implanted within a body;
  - placing an iontophoretic structure on at least a portion of said surface, said iontophoretic structure including,
    - a first plurality of metal particles having a first galvanic electrical potential,
    - a second plurality of metal particles having a second galvanic electrical potential, and
    - an inherently conductive polymer separating said first plurality of metal particles from said second plurality of metal particles, said inherently conductive polymer having a predetermined resistivity for controlling a current flow produced between said first plurality of metal particles and said second plurality of metal particles when said iontophoretic structure is in contact with an electrolytic fluid; and
  - implanting said medical device within said body.
7. A method of protecting a natural body structure with an iontophoretic structure including a first galvanic material having a first electrical potential, a second galvanic material having a second electrical potential, and an inherently conductive polymer separating said first galvanic material from said second galvanic material, said inherently conductive polymer having a predetermined resistivity for controlling a current flow produced between said first galvanic material and said second galvanic material when said iontophoretic structure is in contact with an electrolytic fluid, said first galvanic material including a first plurality of metal particles, said second galvanic material including a second plurality of metal particles, said first and said second plurality of metal particles embedded in said inherently conductive polymer, comprising the steps of:
  - applying said iontophoretic structure in a pre-cured state to said natural body structure; and
  - allowing said iontophoretic structure to cure.