

Pacific University

CommonKnowledge

College of Optometry

Theses, Dissertations and Capstone Projects

5-1990

Adherence of pseudomonas aeruginosa and staphylococcus aureus to hydrocurve II soft contact lenses

Damian S. Gormley
Pacific University

Vang T. Nguyen
Pacific University

Recommended Citation

Gormley, Damian S. and Nguyen, Vang T., "Adherence of pseudomonas aeruginosa and staphylococcus aureus to hydrocurve II soft contact lenses" (1990). *College of Optometry*. 953.
<https://commons.pacificu.edu/opt/953>

This Thesis is brought to you for free and open access by the Theses, Dissertations and Capstone Projects at CommonKnowledge. It has been accepted for inclusion in College of Optometry by an authorized administrator of CommonKnowledge. For more information, please contact CommonKnowledge@pacificu.edu.

Adherence of pseudomonas aeruginosa and staphylococcus aureus to hydrocurve II soft contact lenses

Abstract

There are over 13 million people in the U.S. who wear soft contact lenses (SCL) for refractive correction. Patients who wear SCL are at increased risk for bacterial keratitis. Most bacterial infections of the cornea in these patients are caused by Pseudomonas and Staphylococcus. One of the reasons that these organisms may infect the cornea is their ability to adhere to SCL. Therefore, we investigated bacterial adherence of Pseudomonas and Staphylococcus to soft contact lenses using the agar sandwich technique. Unused hydrocurve II lenses were soaked in a saline solution of Pseudomonas aeruginosa or Staphylococcus aureus. The lenses were then put on nutrient agar and covered with a thin layer of liquid nutrient agar. After incubation, the number of colony forming units (cfu) on the SCL were counted and used to determine the percent of bacterial adherence. Both organisms adhered to the soft lenses with no significant difference between their mean percent adherence.

Degree Type

Thesis

Degree Name

Master of Science in Vision Science

Committee Chair

Diane P. Yolton

Subject Categories

Optometry

Copyright and terms of use

If you have downloaded this document directly from the web or from CommonKnowledge, see the "Rights" section on the previous page for the terms of use.

If you have received this document through an interlibrary loan/document delivery service, the following terms of use apply:

Copyright in this work is held by the author(s). You may download or print any portion of this document for personal use only, or for any use that is allowed by fair use (Title 17, §107 U.S.C.). Except for personal or fair use, you or your borrowing library may not reproduce, remix, republish, post, transmit, or distribute this document, or any portion thereof, without the permission of the copyright owner. [Note: If this document is licensed under a Creative Commons license (see "Rights" on the previous page) which allows broader usage rights, your use is governed by the terms of that license.]

Inquiries regarding further use of these materials should be addressed to: CommonKnowledge Rights, Pacific University Library, 2043 College Way, Forest Grove, OR 97116, (503) 352-7209. Email inquiries may be directed to: copyright@pacificu.edu

ADHERENCE OF
PSEUDOMONAS AERUGINOSA AND STAPHYLOCOCCUS AUREUS
TO HYDROCURVE II SOFT CONTACT LENSES

BY

DAMIAN S. GORMLEY

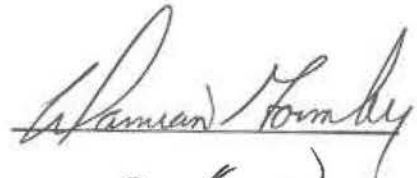

VANG T. NGUYEN



A thesis submitted to the faculty of the
College of Optometry
Pacific University
Forest Grove, Oregon
for the degree of
Doctor of Optometry
May, 1990
May, 1991

Adviser:

Diane P. Yolton, Ph.D., O.D.

Adherence of
Pseudomonas aeruginosa and Staphylococcus aureus
to Hydrocurve II Soft Contact Lenses

AUTHORS: DAMIAN S. GORMLEY
VANG T. NGUYEN

ADVISER: Diane P. Yolton
Diane P. Yolton, Ph.D., O.D.

BIOGRAPHICAL SKETCHES

DAMIAN GORMLEY graduated from St. Martin's College in 1986 with a BS in Biology and a BA in Chemistry. After graduating from Pacific University College of Optometry in 1990, he will serve three years in the U.S. Army.

VANG NGUYEN attended two years at the University of California, Irvine and obtained a BA in Biology at the State University of California, Fullerton in 1987. After graduating from Pacific University College of Optometry in 1991, he plans to enter private practice in Southern California.

Adherence of
Pseudomonas aeruginosa and Staphylococcus aureus
to Hydrocurve II Soft Contact Lenses

ABSTRACT

There are over 13 million people in the U.S. who wear soft contact lenses (SCL) for refractive correction. Patients who wear SCL are at increased risk for bacterial keratitis. Most bacterial infections of the cornea in these patients are caused by Pseudomonas and Staphylococcus. One of the reasons that these organisms may infect the cornea is their ability to adhere to SCL. Therefore, we investigated bacterial adherence of Pseudomonas and Staphylococcus to soft contact lenses using the agar sandwich technique. Unused hydrocurve II lenses were soaked in a saline solution of Pseudomonas aeruginosa or Staphylococcus aureus. The lenses were then put on nutrient agar and covered with a thin layer of liquid nutrient agar. After incubation, the number of colony forming units (cfu) on the SCL were counted and used to determine the percent of bacterial adherence. Both organisms adhered to the soft lenses with no significant difference between their mean percent adherence.

ACKNOWLEDGEMENTS

Special thanks to Mrs. Connie Basinski from Tuality Community Hospital for the bacterial cultures. Also, thanks to Dr. Cristina Schnider for providing the contact lenses and Dr. Diane Yolton for her invaluable advice and guidance.

INTRODUCTION

Soft contact lenses (SCL) have become a popular modality for the correction of refractive error. The ease of adaptation, high degree of comfort, and prolonged wearing time make them very appealing to the patient. But coinciding with this popularity is the increased incidence of bacterial corneal ulcers. New data shows a 0.2 percent incidence with extended wear (EW) SCL and a 0.04 percent incidence with daily wear (DW) SCL.²¹ By relating the incidence with prevalence, these low incidences with 4 million EW wearers yields a prevalence of an estimated 12,000 to 20,000 cases of EW contact lens-induced bacterial keratitis a year.^{5,21}

The most prevalent organisms found to cause bacterial keratitis are Pseudomonas aeruginosa and Staphylococcus aureus.^{4,8} In the conjunctival flora, S. aureus is one of the most commonly occurring bacteria on the healthy eye¹¹, while Pseudomonas is a transient opportunist not normally present in the eye. P. aeruginosa is the most often cultured organism from corneal ulcers while S. aureus which is more available in the conjunctiva to infect the cornea causes a lesser number of corneal ulcers. This leaves a mystery as to the higher prevalence of Pseudomonas keratitis versus keratitis due to S. aureus or other microorganisms, especially since S. aureus is present in a higher number of normal conjunctival flora than is P. aeruginosa.^{15,18}

Ocular infection caused by Pseudomonas, particularly in the normal eye of a healthy patient, is generally thought to follow trauma.²² It has been shown experimentally that bacteria will adhere to injured corneas in preference to those with intact epithelium.¹⁶ The trauma theory has

gained support from a study which has suggested that Pseudomonas-contaminated unused SCL (70% water) led to keratitis only on injured corneal epithelia (rabbit corneas).⁶ Trauma to the corneal epithelium can occur during lens insertion or removal. Another theory as to the increased prevalence of P. aeruginosa in bacterial keratitis is that the wearing of SCL reduces the normal oxygen level to the epithelium. Hypoxic damage to the epithelial barrier may provide the same portal of entry for pathogens as trauma does. Also the use of extended-wear SCL, perhaps more than daily-wear, may disrupt some of the eye's protective mechanisms, such as the flushing action of the tears and an intact corneal epithelium, thereby increasing opportunity for corneal ulcers to occur.^{13,19,20}

The bacteria can enter the eye from several sources: contaminated solutions, improper disinfection, lens cases and the hands during contact lens manipulation. A study by Donzis et al⁵, showed about 50% of patients had contaminated contact lens care systems, regardless of whether DW or EW SCL. The most common organism isolated from contaminated care systems was coagulase-negative staphylococcus (50%), with Pseudomonas isolated from about 20% of the contaminated systems. When daily-wearers were compared to extended-wearers, there was a significantly greater frequency of contaminated commercial solutions among the patients wearing EW lenses, presumably because these solutions were opened and used for a longer period of time.¹¹

Once bacteria get into the eye, they may adhere to the contact lens. Studies using a scanning electron microscope to examine the anterior lens surface, demonstrated bacteria were adherent to SCL.⁷ It is believed that

lens surface coatings permit bacteria to accumulate and attach, which is necessary for persistence and colonization of bacteria on the lens surface.

The reason why bacterial ulcers in SCL wearers is more often caused by P. aeruginosa than S. aureus is still unclear. One reason may be that Pseudomonas, once it gets in the eye, selectively adheres to the SCL.^{4,7} There are several laboratory methods to measure bacterial adherence to SCL. Direct counts of stained bacteria with image analysis are only useful for very small surface areas.¹ An indirect method of counting radiolabelled bacteria is relatively insensitive.⁹ Our study was designed to quantify the adherence of P. aeruginosa and S. aureus to SCL in vitro using the agar sandwich method. The agar sandwich method is simple, inexpensive and seemingly sensitive for small numbers of adherent bacteria.

MATERIALS AND METHODS

Never-worn Hydrocurve II (Sola/Barnes-Hind) 45% and 55% water soft contact lenses were used to test bacterial adherence because of their availability. The differences between the contact lenses were in base curve (8.3 to 9.8), power (-3.25 to +16.00), center thickness (0.05 to 0.41) and diameter (13.5 to 15.5).

Staphylococcus aureus and Pseudomonas aeruginosa used in the adherence assay were obtained from a nearby hospital lab. They were isolated from patients with non-ocular disease. The organisms were grown at 37°C on nutrient agar (NA) and were transferred every seven days throughout the study.

Tubes of ten ml of tryptic soy broth (TSB) were inoculated with the organisms and incubated overnight. They reached a concentration of approximately 10^8 cfu (colony-forming units)/ml. The bacteria were centrifuged for 5 min @ 4500 rpm and washed twice with 10ml of sterile isotonic saline (SIS). They were then incubated in 9ml of TSB for three hours @ 37°C to obtain actively dividing bacteria at an estimated concentration of 10^8 bacteria/ml. The organisms were then diluted to estimated concentrations of 10^4 and 10^3 bacteria/ml and aliquots of 2ml of these suspensions were placed into sterile SCL vials. In addition, 0.1ml of each suspension (10^4 & 10^3) was spread on an individual NA petri dish and incubated for 24 hours @ 37°C to determine the total number of cfu in soaking solution.

In vitro Adherence Assay(Agar Sandwich Technique). Each contact lens was transferred to an individual vial that contained 2ml of a suspension of bacteria and soaked at room temperature (23°C) for three hours. Ten ml of SIS were added to each vial and the vial was vortexed for 5 seconds. The SIS was poured out and the contact lens was then rinsed with another 8ml of SIS. The lens was then put on a plate of NA with SCL tweezers and gently covered by a thin-layer of liquid NA to encase the lens in an agar sandwich. The plate was lightly swirled in a circular motion before it solidified so as to disperse any excess saline on the lens which would otherwise result in confluent growth. The petri dish containing the agar sandwich was incubated for 16 hours @ 37°C . A cfu count was made on each lens using a binocular dissecting microscope.

FLOWCHART

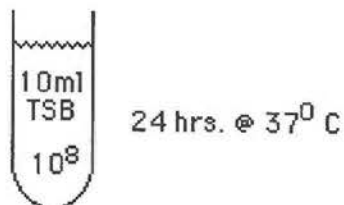

- 1) Centrifuge
- 2) Wash 2x with 10 ml SIS

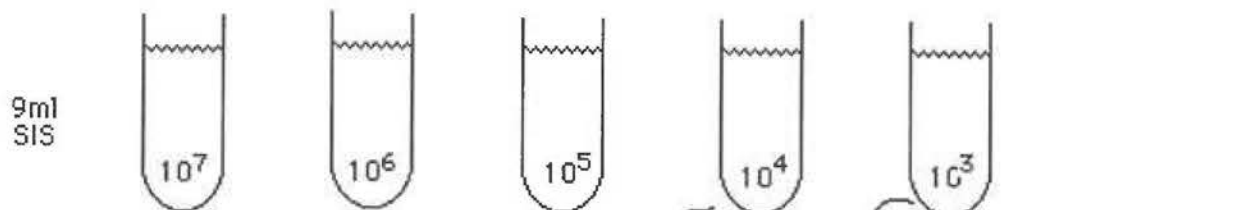
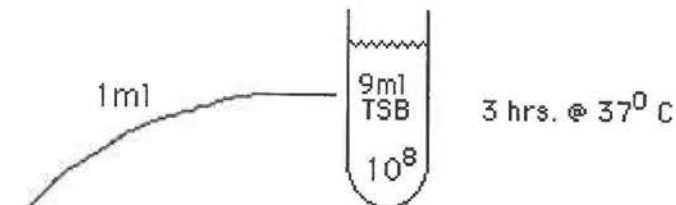

- Incubate 24hrs. @ 37⁰ C
- select plate 30-300cfu
- *cfu *dilution = # cfu/ml

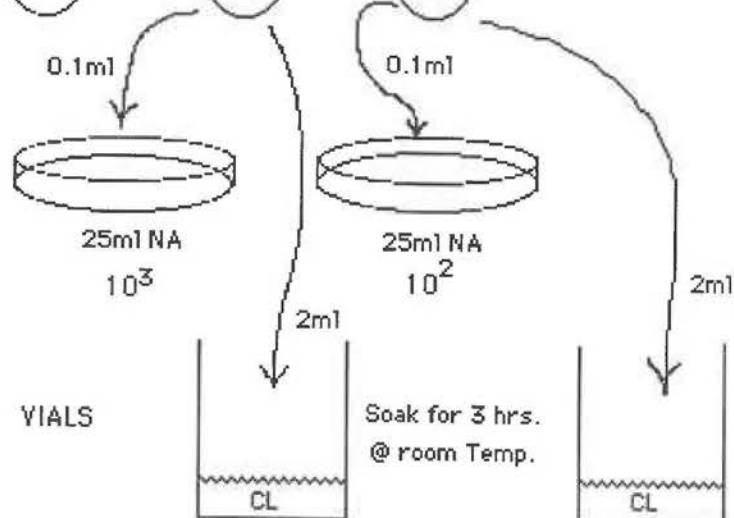

MATERIALS:

** 1 trial/bacteria

TSB - 50ml

NA - 500ml

SIS - 1L

Petri dish - 8

Pipettes - 14 one ml

4 two ml

Test tubes - 18

CL Vials - 4

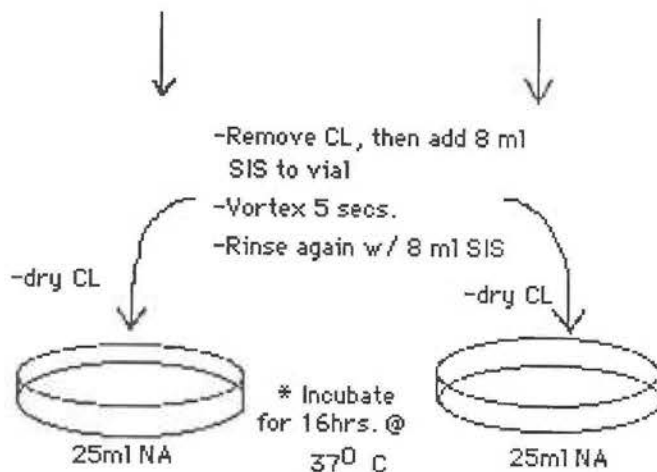

- Remove CL, then add 8 ml SIS to vial
- Vortex 5 secs.
- Rinse again w/ 8 ml SIS

The adherence of the bacteria to the contact lens is expressed as the percentage adherence per cm² of the lens:

$$\frac{\text{cfu/cm}^2 \text{ lens surface}}{\text{Total cfu in soaking soln}} * 100 = \% \text{ Adherence}$$

Formulas used for calculation of contact lens (CL) surface area (A):¹⁴

$$A_{CL}(\text{cm}^2) = A_{\text{back surface}}(\text{BS}) + A_{\text{front surface}}(\text{FS})$$

$$A_{BS} = 2\pi r (r - (0.5 * (4r^2 - d^2).5))$$

n = 1.43 Hydrocurve II SCL
r = base curve in mm
d = diameter SCL in mm

$$A_{FS} = 2\pi r_1 (r_1 - (0.5 * (4r_1^2 - d^2).5))$$

r₁ = front curve in mm

$$\text{where } r_1 = \frac{61490r + 43tFr + 18490t}{143Fr + 61490}$$

r = base curve in mm
t = center thickness
F = power CL in diopter

The mean percent adherence and the standard deviation were calculated by using the sum of the percent adherence of each bacterial strain onto the SCL. A two-grouped unpaired t-test was used to compare the calculated mean percent adherence between P. aeruginosa and S. aureus trials. Correlation coefficients were computed by comparing the total cfu in the soaking solution from each trial and the percent adherence of P. aeruginosa and of S. aureus.

RESULTS

The lens parameters, calculated surface area, cfu in soaking solutions, cfu on lenses and percent adherence for S. aureus are shown in Table 1 and for P. aeruginosa are shown in Table 2. The results of the t-test showed that there was no significant difference ($P>0.0829$) between the mean percentage adherence of S. aureus (0.025) and P. aeruginosa (0.016) to the hydrocurve II soft contact lenses (Table 3). The correlation coefficient showed that there was no correlation between bacterial adherence and the number of cfu in the soaking solution for either S. aureus (-0.228) or P. aeruginosa (-0.198). The correlation between the number of bacteria in the soaking solution and the percent adherence for S. aureus is shown in Fig. 1, and for P. aeruginosa in Fig. 2.

Table 1. Lens Parameters, cfu on lens and % adherence S. aureus

Parameters of lens Hydrocurve II						surface area (cm*2)	total cfu in soaking soln	cfu on lens	% adherence
wat %	trial	BC (mm)	c.t. (mm)	F (D)	d (mm)				
55	1	9.5	0.14	+2.25	15.5	4.87	4860	3	0.0130
55	2	9.8	0.15	+2.50	15.5	5.20	5840	3	0.0099
45	3	8.4	0.17	+3.50	14.0	4.07	13070	4	0.0075
45	4	8.8	0.13	+2.00	14.5	4.27	11210	7	0.0146
55	5	8.8	0.18	+4.00	14.5	4.36	9060	10	0.0253
45	6	8.8	0.16	+4.00	14.5	4.36	9060	8	0.0202
45	7	8.4	0.26	+10.00	15.5	4.23	7890	9	0.0270
45	8	9.5	0.14	+3.00	14.5	4.08	8360	9	0.0264
55	9	9.5	0.41	+16.00	15.5	4.24	7950	11	0.0326
45	10	8.9	0.16	+4.00	14.0	3.91	8760	11	0.0321
45	11	9.8	0.12	+1.50	15.5	4.73	4440	7	0.0333
45	12	8.3	0.12	+1.75	13.5	3.65	6400	1	0.0043
45	13	8.8	0.13	+2.00	14.5	4.27	6500	3	0.0108
45	14	8.4	0.13	+2.50	14.0	4.03	2880	3	0.0258
55	15	9.5	0.18	+4.00	15.5	4.95	2680	0	0
45	16	8.9	0.16	+4.00	14.5	4.32	3440	15	0.1009
45	17	9.8	0.12	+1.50	15.5	4.73	5200	6	0.0244
55	18	8.4	0.17	+3.50	14.0	4.07	4790	4	0.0252
55	19	9.5	0.37	+14.00	15.5	4.67	2920	2	0.0147
55	20	9.8	0.15	+2.50	15.5	5.20	4890	10	0.0393
55	21	8.9	0.16	+4.00	14.0	4.75	4360	6	0.0290

Table 2. Lens Parameters, cfu on lens and % adherence *P. aeruginosa*

Parameters of lens Hydrocurve II						surface area (cm*2)	total cfu in soaking soln	cfu on lens	% adherence
wat %	trial	BC (mm)	c.t. (mm)	F (D)	d (mm)				
55	1	8.9	0.13	+2.00	14.5	4.24	3960	1	0.0059
55	2	8.9	0.13	+2.50	14.5	4.25	5760	3	0.0122
45	3	8.9	0.05	-3.25	14.5	4.09	11020	5	0.0110
55	4	8.9	0.16	+3.00	14.5	4.27	9580	2	0.0048
55	5	8.5	0.41	+16.00	14.0	3.69	3320	1	0.0082
55	6	8.8	0.41	+16.00	14.5	3.85	3320	2	0.0156
45	7	8.8	0.13	+2.00	14.5	4.27	6200	4	0.0150
55	8	8.4	0.17	+3.50	14.5	4.23	4280	2	0.0110
55	9	9.5	0.37	+14.00	15.5	4.67	8280	8	0.0207
55	10	8.8	0.18	+4.00	14.5	4.36	7620	6	0.0180
45	11	8.9	0.12	+1.50	14.5	4.22	3320	2	0.0143
55	12	9.8	0.14	+2.00	15.5	4.75	3200	1	0.0066
45	13	8.9	0.08	-1.00	14.5	4.14	2888	3	0.0251
45	14	8.5	0.13	+2.50	14.0	4.00	2720	3	0.0275
55	15	8.8	0.37	+14.00	14.5	4.24	3080	4	0.0306
55	16	9.5	0.37	+14.00	15.5	4.67	3080	3	0.0208
45	17	8.8	0.18	+4.00	14.5	4.36	2520	1	0.0091
45	18	8.9	0.12	+1.25	14.5	4.21	2900	4	0.0326
55	19	8.5	0.41	+16.00	14.0	3.69	4120	4	0.0263
45	20	8.5	0.13	+2.75	14.0	4.02	2180	0	0
45	21	8.9	0.13	+2.25	14.5	4.23	2460	2	0.0192

Table 3. Means % adherence and Standard Deviation

	<i>S. aureus</i>	<i>P. aeruginosa</i>
Mean	0.025	0.016
Std. dev.	0.02	0.009
Minimum	0	0
Maximum	0.101	0.033

* % adherence not significantly different $p = 0.0829$

Figure 1. Correlation of number of *Staphylococcus aureus* in soaking solution versus percent adherence.

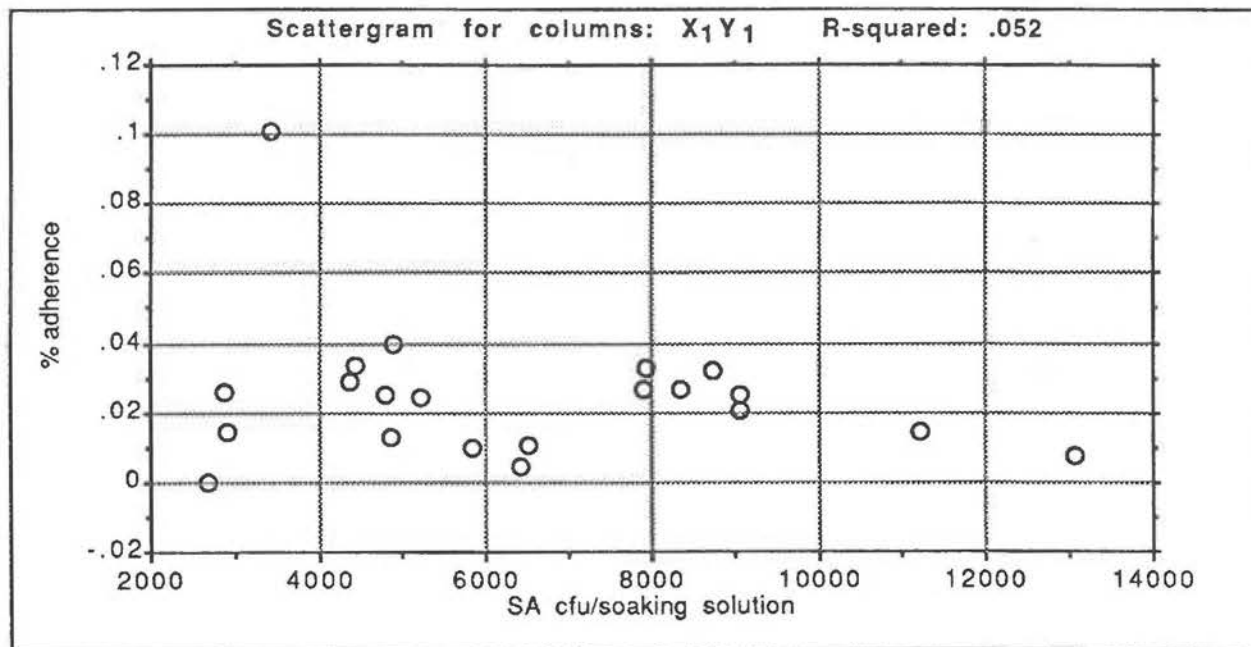
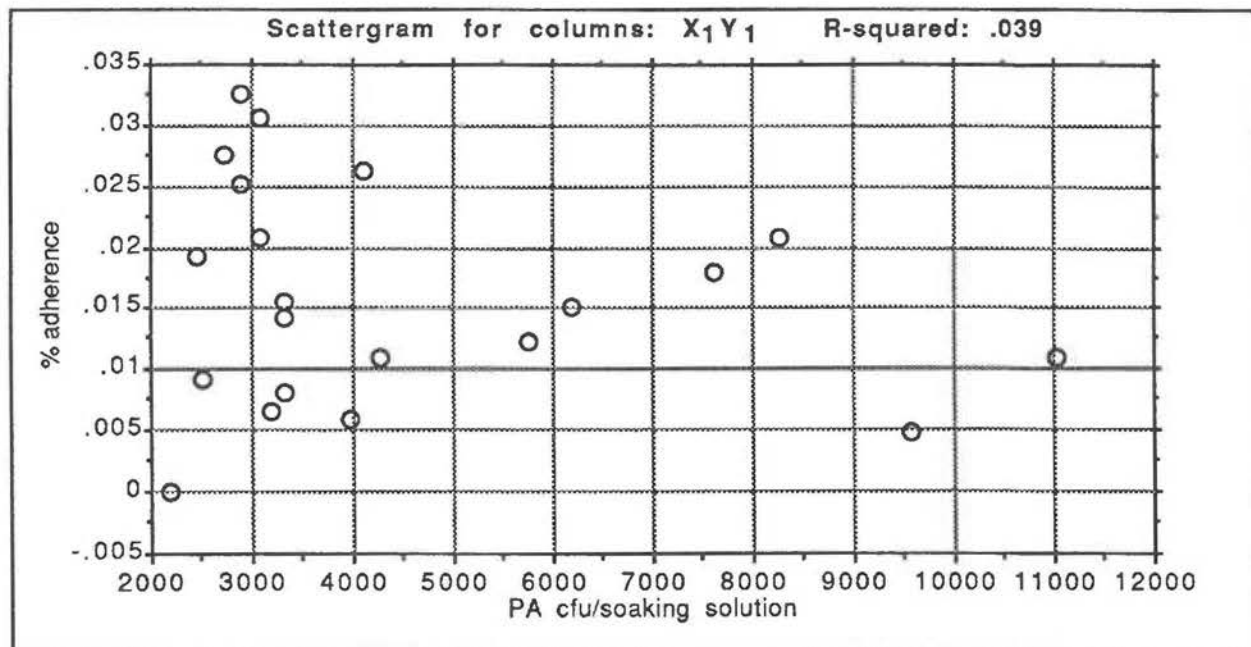

Figure 2. Correlation of number of *Pseudomonas aeruginosa* in soaking solution versus percent adherence.



DISCUSSION

The agar sandwich technique offers a reliable means to measure small numbers of adherent bacteria to contact lenses. This method allows for quick identification of colonies and spatial localization. Bacterial colonies could be fairly easily separated into adherent colonies by their flat morphology on the contact lens from the oval shaped colonies growing on or in the nutrient agar. One difficulty encountered was that only small numbers of adherent bacteria could be quantified, since confluent growth prevents accurate counting.

The mean percent of adherence per cm^2 was approximately 0.025% and 0.016% for S. aureus and P. aeruginosa respectively. An unpaired t-test comparison of adherence between the bacterial strains showed that the mean percentages were not significantly different at a 5% level ($P > 0.0829$). These results conflict with previous data³ which showed a greater mean adherence for S. aureus than P. aeruginosa to SCL. Even though the techniques used were similar, other factors involved may have contributed to the differences in adherence. Selective bacterial adherence may be related to specific bonding sites, surface charges, and hydrophobicity. The other study³ used contact lenses of a different material, water content, and parameters. In addition, different strains of P. aeruginosa and S. aureus isolated from corneal ulcers were used.

There was a very low correlation between adherence and the number of cfu in the soaking solution for both S. aureus (-.228) and P. aeruginosa (-.198). Therefore, one may conclude that the concentration of bacteria in the soaking solution had no effect on the number of adherent bacteria onto the SCL. Perhaps one reason for this is that there is a limit as to the

number of bacteria that could adhere to the SCL due to competition for a few available binding sites. The percent adherence then, would be independent of the concentration in the soaking solution as long as a minimum concentration was in the soaking solution.

Further research is needed into this area to investigate why bacterial corneal ulcers caused by P. aeruginosa are more prevalent among EWSCL. The possibility that the integrity of corneal epithelium from soft contact lens wear may be compromised, and thus is more vulnerable to infections caused by P. aeruginosa is but one reason. The adherence of bacteria to the SCL is another area to be investigated. Perhaps different bacterial strains adhere to a greater or lesser degree. Strains of bacteria isolated from bacterial keratitis should be compared to those isolated from other infections. Different contact lens materials and lenses with different percent water content should also be used to investigate bacterial adherence.

The agar sandwich technique is useful to determine bacterial adherence and should be used to further investigate why patients with daily-wear lenses or those with extended-wear lenses are at greater risk to microbial keratitis than non-contact lens wearers.

REFERENCES

1. Absolom DR, Lamberti FV: Surface Thermodynamics of Bacterial Adhesions. *Appl Environ Microbiol* 1983; 46:90-97.
2. Adams et al: Corneal Ulcers in patients with Cosmetic Extended-Wear Lenses. *Am. J. Ophthalmol.* 1983; 96:705-709.
3. Badenoch PR, Dart JK: Bacterial Adherence to Contact Lenses. *CLAO J.* 1986; 12:220-224.
4. Cohen et al: Corneal Ulcers Associated with Cosmetic Extended-Wear Soft Contact Lenses. *Ophthalmology* 1987; 94:109.
5. Donzis et al: Microbial Contamination of Contact Lens Care Systems. *Am. J. Ophthalmol.* 1987; 104:325-333.
6. Duran et al: Hydrogel Contact Lens-Induced Pseudomonas Keratitis in a Rabbit Model. *Cornea* 1987; 6/4:258-260.
7. Fowler et al: Attachment of Bacteria to Soft Contact Lenses. *Arch Ophthalmol* 1979; 97:659-660.
8. Galentine et al: Corneal Ulcers Associated with Contact Lens Wear. *Arch Ophthalmol* 1984; 102:891-894.
9. Harber MJ et al: A Rapid Bioluminescence Method for Quantifying Bacterial Adhesion to Polystyrene. *J Gen Microbiol* 1983; 129:621-632.
10. Hassman G, Sugar J: Pseudomonas Corneal Ulcer with Extended-Wear Soft Contact Lenses for Myopia. *Arch Ophthalmol* 1983;101:1549-50.
11. Hovding G: The Conjunctival and Contact Lens Bacterial Flora during Lens Wear. *ACTA Ophthalmol* 1981; 59:387-401.
12. Krachmer J, Purcell J: Bacterial Corneal Ulcers in Cosmetic Soft Contact Lens Wearers. *Arch Ophthalmol* 1978; 96:57-61.
13. Mondino BJ, Weissman BA, and Pettit TH,: Corneal Ulcers Associated with Daily-Wear and Extended-Wear Contact Lenses. *Am. J. Ophthalmol.* 1986; 102:58.

14. Phillips AJP: Alterations in Curvature of the Finished Corneal Lens. *The Ophthalmic Optician* 1969; 9:1100-1104, 1109-1110.
15. Pitts ER, Krachmer JH: Evaluation of Soft Contact Lens Disinfection in the Home Environment. *Arch Ophthalmol* 1979; 97:470-472.
16. Ramphal et al: Adherence of *Pseudomonas aeruginosa* to the Injured Cornea: A Step in the Pathogenesis of Corneal Infections. *Am. Ophthalmol.* 1981; 13:421-425.
17. Rauschl RT, and Rogers JJ.: The Effect of Hydrophilic Contact Lens Wear on the Bacterial Flora of the Human Conjunctiva. *Int. Contact Lens Clin.* 1978; 58:37.
18. Smolin G et al: The Microbial Flora in Extended-Wear Soft Contact Lens Wearers. *Am. J. Ophthalmol* 1979; 88:543-547.
19. Weissman BA, Mondino BJ, and Hoffauer JD.: Corneal Ulcers Associated with Extended-Wear Soft Contact Lenses. *Am. J. Ophthalmol.* 1984; 97:476.
20. Weissman BA, Remba MJ, and Fugedy E.: Results of the Extended-Wear Contact Lens Survey of the Contact Lens Section of the Am. Optometric Assoc. *J. Am. Optom. Assoc.* 1987; 58:166.
21. White, Paul: The \$64,000 Question- What is the Safe Duration of Extended Wear?. *Spectrum*; February 1990: 45-63.
22. Wilson et al: *Pseudomonas* Corneal Ulcers Associated with Soft Contact Lens Wear. *Am. J. Ophthalmol* 1981; 92:546-554.