

By using Internet of Things Analysis of Waste Monitoring System

¹Senthur Selvi V, ²Fathima Mubarakkaa M

¹PG Student, ²Assistant Professor

Department of Computer Science and Engineering
Einstein College of Engineering, Tirunelveli, Tamil Nadu, India

Email: senthurselviv@gmail.com

DOI:

Abstract

Metropolitan territories in urban areas are confronting poor strategy for waste administration. Since there is quick increment of urban populace unhygienic conditions are winning. To maintain a strategic distance from this condition and to enhance the personal satisfaction powerful waste administration is utilized. In proposed framework, squander container is checked with the sensors and GSM framework. An android application is utilized to screen data with respect to squander independent of area. By this squanders are expelled effectively.

Keywords: AT89s52 microcontroller, GSM, IR sensor.

INTRODUCTION

The Internet of Things (Iota) is an arrangement of interrelated registering gadgets, mechanical and computerized machines, items, creatures or individuals that are given remarkable identifiers and the capacity to exchange information over a system without expecting human-to-human or human-to-PC communication. Web of things makes utilization of trend setting innovations for various exercises. The sensors will be set in the street and all lanes. Gathered information from sensor will be sent to another sensor for preparing.

Strong waste administration is a major test in urban zones for the majority of the nations all through the world. A proficient waste administration is a pre demand for keep up a sheltered and green condition as there are expanding all sort of waste transfer. There are numerous advancements are utilized for waste accumulation and additionally for all around overseen reusing. The Information gathering is huge and lumbering. The simultaneous impacts of a quick national development rate, of an extensive and

thick local location and a squeezing interest for urban natural security make a testing system for waste administration. The multifaceted nature of setting and systems is to be sure an essential worry of nearby city specialists because of issues identified with the accumulation, transportation and handling of private strong waste today the trash gathering is manual which takes a considerable measure of endeavors and is tedious.

In this undertaking we are utilizing programmed system to distinguish rubbish level in Garbage Can. Additionally when the Garbage Can is full/over streaming then a SMS is sent to the server from where all the trash accumulation vehicles are allocated. Additionally we have a Load cell based gauge sensor which will detect the heaviness of the Garbage Can and when the weight crosses the set point the SMS is sent to trash accumulation focus.

Related Works

Arebey M., Hannan[1], examines safe transfer of waste. With this framework we will ready to screen the gathering and transportation framework and deals with

the procedure. It gives continuous data of strong waste from age point to transfer site. The advancement comprises of new innovations which might be gainful to urge the specialists to progress in the direction of further enhancement of the present framework. The advancement of the application with recognizable proof and correspondence innovations, for example, RFID and GSM utilizes some product bundles.

Islam, M.S[2], proposes a propelled strategy in which squander the executives is mechanized. Radio recurrence recognizable proof (RFID) is a standout amongst the most encouraging and foreseen advances as of late. The framework makes utilization of radio recurrence (RF) labels and web bolster. This work displayed here positively gives a novel methodology in dealing with and arranging off the everyday strong squanders in a proficient and simple way. The framework comprises of four fundamental subsystems specifically Smart Trash System (STS), Local Base Station (LBS), Smart Vehicle System (SVS) and Smart Monitoring and Controlling Hut (SMCH). The proposed framework would have the capacity to mechanize the strong waste observing procedure and the board of the general gathering process.

In the principal stage, shading angle picture of unique picture ought to be ascertained and after that it is altered by morphological force minima, which should utilize markers extricated in two diverse ways. Ultimately, primer division result is gotten by watershed change works on the altered shading inclination picture. To understand the over-division of mechanical strong waste and other ground objects, locale combining task is performed by the similitude measure paradigm dependent on sectioned items' shading histogram Bhattacharyya coefficient.

Chen Tao[4], examine six unique methods were utilized to outline a multiyear old trench limit at Los Alamos National Laboratory. Information from verifiable ethereal photos, an attractive angle overview, airborne multispectral and warm infra-red symbolism, seismic refraction, DC resistivity, and aggregate field magneto meter were used in this procedure. Every datum set demonstrated a southern and northern edge for the trench. Normal areas and 95% certainty limits for each edge were resolved along a review line opposite to the trench. Trench edge areas were genuinely predictable among every one of the six strategies. Results from a displaying exertion performed with the aggregate attractive field information were the slightest steady. Be that as it may, every strategy given exceptional and reciprocal data. The incorporation of this data prompted a more total portrayal of the trench limits and substance.

Issac, R; Akshai, M[5], surveys and shows a method that can be connected in performing extensive inventories of known and obscure, dynamic and latent, squander transfer locales over province estimate territories. The means depicted incorporate pre-overview exercises, assessment and obtaining of elevated photos, advancement of the characterization framework, open data studies, air photograph investigation, site dereferencing, site prioritization and follow-up air photograph examination, and execution of a checking program.

PROPOSED SYSTEM

In this task, the framework essentially contains microcontroller, IR sensor, Load Cell, GSM, GPS, LCD, web server and android application. In India, existing framework has no legitimate method for expelling squanders [8][9]. The waste is dumped in numerous regions and the transfer isn't considered and stays there for a long time causing sullied illnesses.

In this manner "Effective Waste Management" is presented in this paper. The dustbin is kept in different spots. The dustbin is set with sensor called IR sensor. IR sensor is utilized to check the misuse of dustbin. While surpassing the edge esteem this data alongside the area of dustbin by GPS is sent through GPRS/GSM framework. The android application with the assistance of co ordinates ready to find the dustbin through server[6][7]. Presently a-days all ordinary

citizens keep advanced mobile phones. So our undertaking of keeping the city clean turns out to be simple. Anybody can download application and utilize the application for waste relocation.

System Architecture

The figure 1 represents the hardware architecture of the system. It tells about hardware and the interconnections in the system

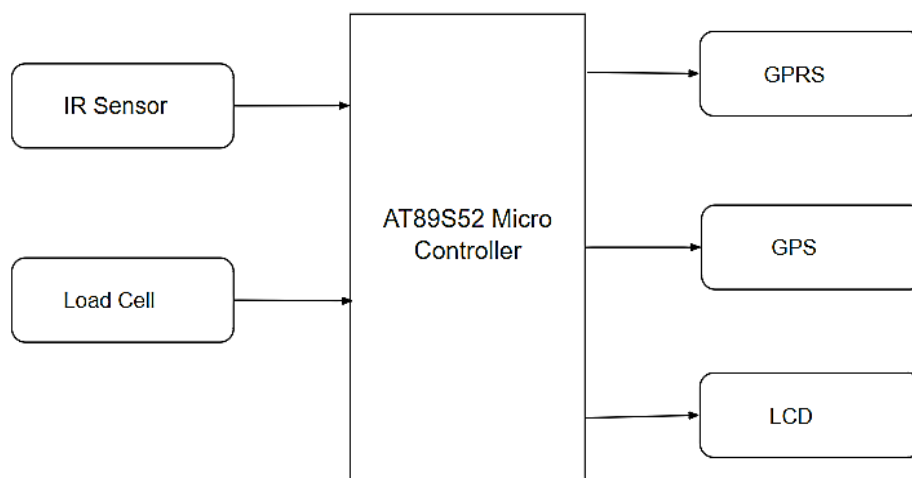

Fig: 1.Architecture of waste management system

The microcontroller at the focal point of the square outline. It goes about as a control unit. The microcontroller is stacked with projects. The microcontroller makes a move dependent on the contribution of the sensors. In this venture we are utilizing IR sensors and load cell to screen the loss in the dustbin. IR sensor is utilized to identify the waste dimension and to quantify the measure of waste in the dustbin. Load Cell is utilized to check the heaviness of the dustbin. Red and Green LCD are utilized to demonstrate filled and void dimension of the dustbin separately. At the point when squander level identified by sensor surpassed an edge esteem, this data alongside utilizing GPS to distinguish area of the dustbin will get refresh on the web cloud server through GPRS. Android gadget gets this data from server and the region of the dustbin is

situated by looking at directions utilizing Map and afterward advises the particular specialists to gather the waste. This will oversee waste effectively [10][11].

In an android application, GUI is produced by signing into the advanced mobile phone the menus will be given by holding and review information. By signing into this application we can see the status and area of the canister.

Advantages of Proposed System

- Cost efficiency is acquired
- Waste can be collected in smart and fast manner
- Waste collection can be done in efficient manner saving the fuel of the vehicle
- Requires less manual effort.

IMPLEMENTATION

The implementation consists of three modules: the embedded, android and the web server. The embedded module consists of IR sensor, Load Cell, LCD, GSM, GPRS, AT89S52, Atmel microcontroller. Here the microcontroller forms the control unit of the system. The microcontroller acts as an interface between all the devices connected in the system. The microcontroller used here is AT89S52, Atmel microcontroller. The status of the bin can be viewed in LCD near the bin. IR sensor and Load cell is used to monitor the waste in the bin. The GPRS and GPS are used for communicational purpose. GPS provide location of the bins to the users. Data exchange with microcontroller and web

server is happened through GPRS [12][13].

The above demonstrates the AT89S52 microcontroller. The microcontroller is for programming purposes. At first, the sensors get coded and the code is dumped into microcontroller. LCD is utilized to show the status of the receptacle. The android module has an application by which client will think about the status and area of the dustbin from the server. By signing into the application the client can get to the substance in it[14]. The web server module comprises of data with respect to the canister and furthermore refreshing the progressions made given by the framework.

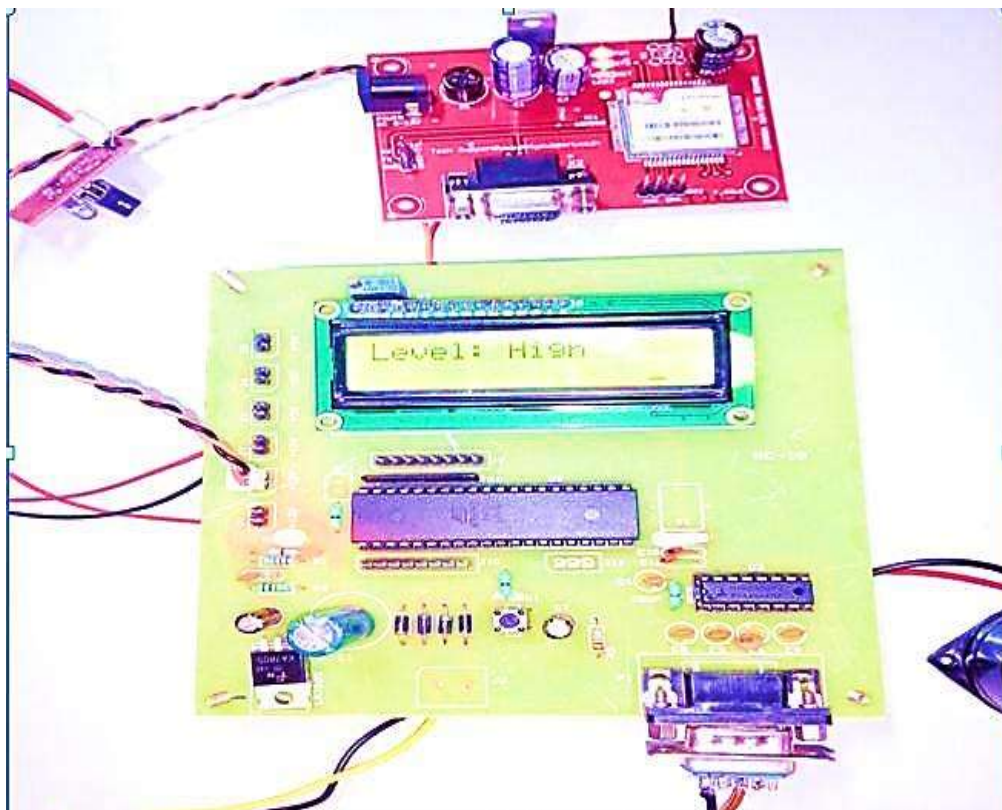

Fig: 2.AT89S52 Microcontroller with LCD display

The general framework capacities are as per the following: Initially squander checking applications must be downloaded. The client needs to give the data to login. After signed in the client is

furnished with web server accreditations where he needs to sign in for getting to the web server. By knowing the status of the container he can get area of the receptacle through waste checking framework. In the

event that the container is vacant and the waste is tossed into canister this information gets refreshed in the server [15][16].

CONCLUSION

The Smart waste checking framework causes the general population to keep the city clean giving an application to realize the data with respect to squander. The application likewise gives the data, for example, regardless of whether the dustbin is filled, semi filled or void. This diminishes time and makes individuals to toss squander just in the container. The future upgrade of this task can be checking the canisters relying upon the waste present. This framework can likewise be actualized by at what time container is filled and the season of gathering of waste. By executing this undertaking we will abstain from flooding of refuse in neighborhood which is beforehand either stacked physically or with the assistance of loaders in customary trucks.

REFERENCE

1. Arebey M., Hannan, M.A.; Basri, H., Abdullah, H. "Solid waste monitoring and management using RFID, GIS and GSM" IEEE Student Conference on Research and Development (SCoReD), 2009.
2. Islam, M.S.; Arebey, M.; Hannan, M.A.; Basri, H., "Concept, Design and Implementation of Automatic Waste Management System", IEEE International Conference on Innovation Management and Technology Research (ICIMTR), 2012.
3. Longhi, S ; Marzioni, D ; Alidori, E ; Di Buo, G.; Pris, M. ; Grisostomi, M. ; Pirro, M. "Remote Sensing Industrial Solid Waste Image Segmentation Method Based on Improved Watershed Algorithm", New Technology, Mobility and Security (NTMS), 2012 5th International Conference.
4. Chen Tao; Li Xiang, "Municipal Solid Waste Recycle Management Information Platform Based On Internet of Things Technology", Multimedia Information Networking and Security (MINES), 2010 International Conference.
5. Issac, R; Akshai, M. "The use of aerial photographs in county inventories of waste-disposal sites", IEEE Conference Publications, 2013.
6. Aaditya Jain, BhupendraSoni, "Secure Modern Healthcare System Based on IoT and Secret Sharing of IoT Healthcare Data", Internal Journal of Advanced Networking and Applications, Vol. 8, Issue 6, pp 3284-3290, 2017.
7. S. V. Srikanth, P. Pramod, K. Dileep, S. Tapas, M. Patil, and C. Sarat, "Design and implementation of a prototype smart parking (spark) system using wireless sensor networks," in Advanced Information Networking and Applications Workshops, 2009. WAINA '09. International Conference on, May 2009, pp. 401–406.
8. T. Qiu, H. Xiao, and P. Zhou, "Framework and case studies of intelligence monitoring platform in facility agriculture ecosystem," in Agro Geoinformatics (Agro-Geoinformatics), 2013 Second International Conference on, Aug 2013, pp. 522–525.
9. Y. Huang, B. Baetz, G. Huang, and L. Liu, "Violation analysis for solid waste management systems: an interval fuzzy programming approach," Journal of Environmental Management, vol. 65, no. 4, pp. 431 – 446, 2002.
10. G.J. Manderson, "Composing Agricultural and Industrial Wastes" in Biotechnology, Institute of Technology and Engineering, Massey University, North New Zealand, 2011.
11. Longhi, S., Marzioni, D., Alidori, E., BuÒ, G. D., Prist, M. Grisostomi, M., and Pirro, M. "Solid waste

- management architecture using wireless sensor network technology”, in New Technologies, Mobility and Security(NTMS), 5th International Conference on (PP. 1-5),IEEE, 2012.
12. Catania, V., and Ventura, D. “An approach for monitoring and smart planning of urban solid waste management using smart M3 platform”, in Open Innovations Association FRUCT, Proceedings of 15th Conference of IEEE (PP. 24-31), 2014.
 13. Abhishek D., ManeeshJ., Muzammil N., “IoT Based Smart Garbage Detection System”, International Research Journal of Engineering and Technology, Vol. 3, Issue 12,Dec 2016.
 14. Sensors Saravana Kumar K , Priscilla P, Germiya K Jose,Balagopal G., “Human Detection Robot using PIR” IEEE transaction on sensors, 2015.
 15. Pedro Reis, RuiPitarma, CelistinoGoncalves, Intelligent System for Valorizing Solid Urban Waste, Filipe Caetano Faculty of Engineering UBI University of Beira Interior Covilha, Portugal, 2015.

| |
|------------------------------|
| <i>Cite this article as:</i> |
|------------------------------|