

ROBOTIC CAR USING ARDUINO WITH BLUETOOTH CONTROLLER

VIJAYALAKSHMI S^{1*} & ARCHANA M²

¹*Department of Computer Science and Engineering, Adhiyamaan College of Engineering, Hosur, Tamil Nadu, India*

²*Assistant Professor, Department of Computer Science and Engineering, Adhiyamaan College of Engineering, Hosur, Tamil Nadu, India*

***Corresponding Author:** *Vijayalakshmi S; Final year, Department of Computer Science and Engineering, Adhiyamaan College of Engineering, Hosur, Tamil Nadu, India, India*

ABSTRACT

The Android controlled temperature sensing RoboCar. The working is based on Android OS, Arduino, L298N motor, DC motor driver, temperature sensor-DHT11 and Bluetooth module. Arduino is an open-source prototype platform. Sensing the environment of the temperature sensor. Remote control car, with an Arduino, L298N motor and Bluetooth module. Sensing the temperature, with an DHT11, Arduino and Bluetooth module. Upload the code to the Arduino using the knowledge of programming. The Arduino code simulated on software and be interface with the hardware. The device can be controlled by any smart device with android. AirDroid is an app exclusive to Android which enables you to connect your device to PC through a Wi-Fi controller of wireless network. It is used to connect the mobile camera to view in our pc to fixing in the car. It also used to view the location of the car. The Robotic car sense the temperature to view by the mobile app. All the controls of the vehicle on the app on that device. It is used to sense the environment of the military force before doing some of the process. It is used for the sensing the environment of the system.

KEYWORDS: *Android OS, Bluetooth, App controller, DC motors, L298N Motor Driver, Temperature sensors, Arduino Uno, Battery, PC*

INTRODUCTION

Smartphone has quite changed the traditional ways of human to machine interaction. Smartphone is now a vital part of a person's life. Android is a software platform for mobile device that includes an operating system, middleware and key applications. Android is a safe and secure operating system. All of its essential tools are combined in software called SDK which stands for Software Development Kit. We know that all manual operations have been replaced by automated mechanical operations. Our main objective of writing this paper is to control the robot by sensing the temperature of the environment using Bluetooth app and view the direction of the car using mobile camera and also find the location of the robot. Bluetooth is used for its various advantages over other wireless technologies. Hardware technology utilized in smart phones has also greatly

improved. Hence, we can say that Android smartphones will serve a great benefit for industrial, commercial and other general-purpose applications.

The DC motors are widely used for providing variable speed drive system in industrial applications resembling automation, electrical traction, military instrumentality, fixed disk drives, thanks to their high potency, noise-free operation, compactness, dependability and low maintenance and cost. Many connection technologies are used nowadays such as GSM, GPRS, Wi-Fi, WLANs and Bluetooth. Every technique has its own distinctive characteristics and applications. Among these wireless connections, Bluetooth and Wi-Fi technology is usually enforced.

The system hardware consists of a controller equipped with Bluetooth communication module. It'll be connected to the motors and other alternative components of robotic car. When the robot app is turned on and is connected with the current system via Bluetooth, one will operate the car by giving wireless commands from the app using the functions already programmed in the app. The vehicle will move all four told directions: left, right, front and back.

For forward movement, movement of both the motors will be in the same direction and for backward motion; movement of the motors will be in opposite direction. For left and right movements, either of the motors will rotate and to stop both the motors will stop. Instructions are given to the motors through the mobile app by the user.

LITERATURE SURVEY

Various researches have been made by different researchers for developing this project. However, they serve a different application and have different technologies implemented. Some of those papers are mentioned below stating their technology and application.

Jorge Kazacos Winter [2] has developed android controlled robot automation. Main aim of his project was the transfer of information wirelessly between a smartphone and the robot and developing the robot and its communication system underneath a low price and open source philosophy. He used 3D design technique to style the structure of the robot with the facilitation of parametrical modelling software. The style, when fed to the 3D printer can print the parts of the robot in a layered manner one by one and can then use these parts to assemble the robot simply. He has used Arduino micro-controller and Wi-Fi technology in this robot.

M. Selvam [4] in his paper has design to develop a robotic system which has a wireless camera attached to the surveillance. Bluetooth was implemented in his project for providing connection between robot and smartphone. Wireless night vision camera was used for providing the remote surveillance. The video which is recorded by camera is then transmitted to TV unit through

Radio Frequency signal. He used 8051 micro controllers for the robotic unit.

Vito M Guardi [1] has evolved the method of Bluetooth technology by developing an android app for a robot which is driven by a microcontroller. The central idea of his work is to show that one android app can be operated using totally different electronic devices. Vito M Guardi has invented a communication protocol for android smartphone and robotic platform over a Bluetooth.

Ranjith Kumar Goud and B.Santhosh Kumar [3] have invented a pick and drop robot. They wanted it to be used for diffusing a bomb remotely with safety. For the robotic arm, they used a pair of motors and another pair as the wheels of the robot for controlling the movement. Connectivity is established using Bluetooth. The micro-controller used is LPC2148. They had also attached a wireless camera for remote surveillance. They have worked on this project mainly for industrial and military applications.

Xiao Lu, Wenjun Liu, Haixia Wang, Qia Sun [8] have published a paper based on a project in which the smartphone is capable of IFLYTEK voice as well as handwritten input. The design is therefore robust, suitable, and practical for use and it also ensures the reliability of the full system. For connectivity between the smartphone and robot, wifi is used. Use of wifi makes it easy and absolutely convenient for controlling the robot so that it can act according to the commands.

Arpit Sharma, Reetesh Verma, Saurabh Gupta, Sukhdeep Kaur Bhatia [9] have configured an android smartphone which can control a robot via Bluetooth technology. The phone uses motion sensors and records the gestures sent via an android mobile phone. It also has an inbuilt accelerometer and Bluetooth module for controlling the movements of a robot.

EXISTING SYSTEM

Before they are using the remote device to be control by the robotic car. Remote controller car is a separate device to handle the car using the wired and wireless connection. Camera device are used to Fixing in the car and viewing in the system. It can use the various monitoring system in the car. It can be used also the various alerting system. Robot can used to create different kinds of purpose.

PROPOSED SYSTEM

A Robotic car is controlled by using Android mobile phone. It is needs to touch button in android phone to control the car in forward, backward, left and right directions. So android phone is used as transmitting the device components are Arduino, DC motors, Motor Driver L293D, Battery and Bluetooth module HC-06. The Bluetooth module are placed in car is used as receiver. Bluetooth

module have two different modes one is master mode and second one is slave mode. The car has two dc motors at each of its front and rear side. Front side motor is used for giving direction to car means turning left or right side. And rear side motor is used for driving the car in forward and backward direction used to handle the mobile application. Air Droid application is used to connect the mobile camera device to view in PC device of the car motions.

BLOCK DIAGRAM

The Block Diagram of our system consists of a Bluetooth module, an Arduino kit, a couple of motors for driving the car and temperature sensor.

FIGURE 1: BLOCK DIAGRAM OF THE CIRCUIT

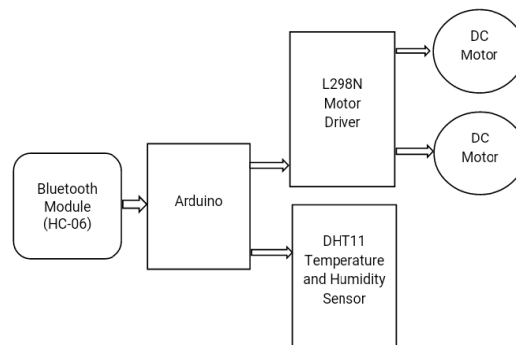

ANDROID SMARTPHONE

Android is a very popular open source operating system (OS), used in mobile devices such as tablets and smartphones. Android has a very user-friendly interface which relies on direct interaction between the user and the device i.e. by using touch gestures. These gestures are like real-world actions, which include swiping, tapping, scrolling and pinching, to control the onscreen objects, together with a virtual keyboard for taking input in text form. In this project, android smartphone has an installed app which is used for controlling the robot unit. The smartphones already come with inbuilt technology to establish connection. The technology we have used is Bluetooth and wifi.

USER INTERFACE

The user interface, of the overall system, is provided using the custom-made android app using Graphical User Interface (GUI). The GUI provides user, the various control modes, to Control dynamically the robot unit. When the app is started, we first establish the connection between the app and RC unit using Bluetooth. The Bluetooth and app are paired is easy to control the robotic car, which is also used to send the data to get the current temperature of the environment. The GUI of android provides a user-friendly real-time experience to the user, to control the robot.

THE ANDROID APPLICATION

An application was developed in the software Android Studio. App can be installed on an Android smartphone to control the RC unit. The app shows buttons for movement of the car in different directions. These commands are as follows: Left, right, forward and backward. The sensor app shows the temperature and humidity value of the current atmosphere which is used to send by the data. The code for the app is written in java.

FIGURE 2: SCREENSHOT OF THE APPLICATION



RC MODULE

RC module is the main working unit of this system. This unit consists of the Arduino chip, the motor drivers, and a Bluetooth module connected to the circuit. L298N Motor driver are used to control the dc motors. The Arduino Uno, which is a small android chip, resides at the center of the unit. It is responsible for communicating with android smartphone, using the Bluetooth module and controls the motors using the motor driver. The RC unit is powered using 6V battery connected to this Arduino chip. It is used another Arduino chip, temperature sensor for sensing the temperature and humidity of the atmosphere. The Paper on Android Controlled Arduino based Robotic Car for controlling the module is received using Bluetooth module HC-06.

FIGURE 3: OUTLAYER OF THE CAR

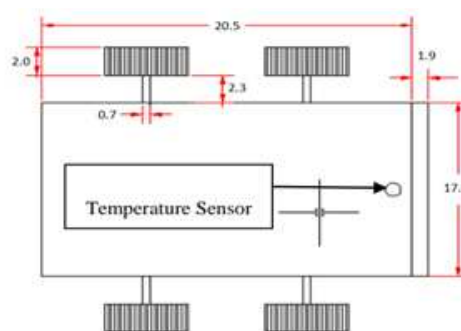

CIRCUIT DIAGRAM

Below is the circuit diagram of the hardware which shows the connections between Arduino, Bluetooth and motors. It also shows a motor driver L298N which is responsible for movement of the motors in either direction. The data is used also the DHT11 sensor. The RxD pin of the Arduino is connected to the TxD pin of Bluetooth and vice versa. Supply of 5V is provided to the motors.

FIGURE 4: CIRCUIT DIAGRAM

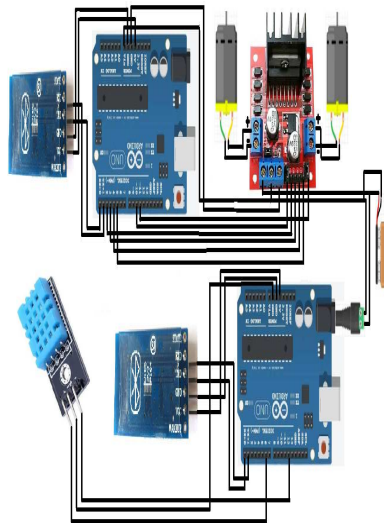

CONCLUSIONS

Thus, in this project, we designed an Android App in the software Android Studio to control the RC module. We have programmed Arduino and designed the RC car as shown in the diagram previously. The car will receive the commands via Bluetooth and move accordingly. It will be used to check the temperature and humidity of the environment.

RESULTS

After simulating the circuit connections, it will be used to detect the Temperature and Humidity of the environment. Connections were made as per the circuit diagram and the file of the code of Arduino was attached to the Arduino Uno.

FIGURE 5: ROBOTIC CAR

The Robotic car will Sense the temperature and humidity it can also view the directions to the P.C by fixing the mobile camera in the car.

FIGURE 6: MOBILE CAMERA DETECTION

REFERENCES

1. *Design of a Bluetooth Enabled Android Application for a Microcontroller Driven Robot* By Vito M. Guardi, (May 2014).
2. *Android Controlled Mobile Robot* By Jorge Kazacos Winter, (July 2013).
3. *Android Based Robot Implementation For Pick and Retain of Objects* By Ranjith Kumar Goud, B. Santhosh Kumar, (Oct 2014).
4. *Smart phone based robotic control for surveillance applications* By M. Selvam, (IJRET 2014).
5. *Controlling a Robot using Android Interface and Voice* By Kishan Raj KC, (2012).
6. *Motion Control of Wheeled Mobile Robot* By Gyula Mester, (SISY 2006).
7. *Design of PI and PID Controllers with Transient Performance Specification* By J. C. Basilio and S. R. Matos, (IEEE 2002).
8. *Robot Control Design Based On Smartphone* by Xiao Lu, Wenjun Liu, Haixia Wang, Qia Sun, IEEE, 978-1-4673-1382, pp-2820-2823, Jun 2013.
9. *Android phone controlled robot using Bluetooth* by Arpit Sharma, Reetesh Verma, Saurabh Gupta, Sukhdeep kaur bhatia, IJEEE, Vol.7, pp-443-448, Nov- 2014.
10. *Range-based navigation system for a mobile Robot*-Neil MacMillan, River Allen, Dimitri Marinakis, Sue Whitesides, IEEE 2010
11. *Smartphone-based Mobile Robot Navigation* -Nolan Hergert, William Keyes, and Chao Wang, spring 2012.

12. *Development Of A Wireless Device Control Based Mobile Robot Navigation System Phey Sia Kwek, Zhan Wei Siew, Chen How Wong, Bih Lii Chua, Kenneth Tze Kin Teo. IEEE 2012.*
13. *Mobile Robot Temperature Monitoring System Controlled by Android Application via Bluetooth T. Maria Jenifer, T. S. Vasumathi Priyadharshini, Raja Lavanya & S. Raj Pandian, IJACTE 2013*
14. *A Bluetooth-based Architecture for Android Communication with an Articulated Robot- Sebastian van Delden and Andrew Whigham, IEEE 2013*
15. *L. Srinivasavaradhan, G. Chandramouli and A. G. Maniprashanna, 2009. 7 TH sense. A multipurpose robot for military. MEMSTECH 5th International Conference on Perspective Technologies and Methods in MEMS Design.*
16. *C. Marques, J. Cristovao, P. Lima, I. Ribeiro, R. Ventura, J. Frazao. 2006. RAPOSA: Semi-Autonomous Robot for Rescue Operations, Intelligent Robots and Systems, IEEE/RSJ International Conference.*
17. *Hou Tsan Lee, Wei Chuan Lin, Ching Hsiang Huang, Yu Jhih Huang. 2011 "Wireless Indoor Surveillance Robot," SICE Annual Conference Waseda University, Tokyo, Japan.*
18. *S. Naskar, S. Das, A.K Seth, A. Nath. 2011. Application of Radio Frequency Controlled Intelligent Military Robot in Defense. Communication Systems and Network Technologies (CSNT), International Conference.*
19. *Luo, R.C., Chou, Y.T., Liao, C.T., Lai, C.C., Tsai, A.C. 2007. NCCU Security Warrior: An Intelligent Security Robot System. Industrial Electronics Society, 2007. IECON 2007. 33rd Annual Conference of the IEEE.*
20. *Yuan Yuan Li; Parker, L.E. 2008. "Intruder detection using a wireless sensor network with an intelligent mobile robot response," Southeastcon, IEEE.*