

THE MAKER APPROACH AT NASA

NEW WAYS THE US SPACE AGENCY
BUILDS SPACECRAFT & EMPOWERS
CITIZENS

Doing It Yourself

Participatory Exploration = A type of Hacking?

Hackers= Tinkers = Makers

Just other kinds of explorers

THIS IS NOT A NEW PHENOMENON!

Did it Themselves: Aircraft



**Albert Santos -Dumont
over Paris, France 1909**

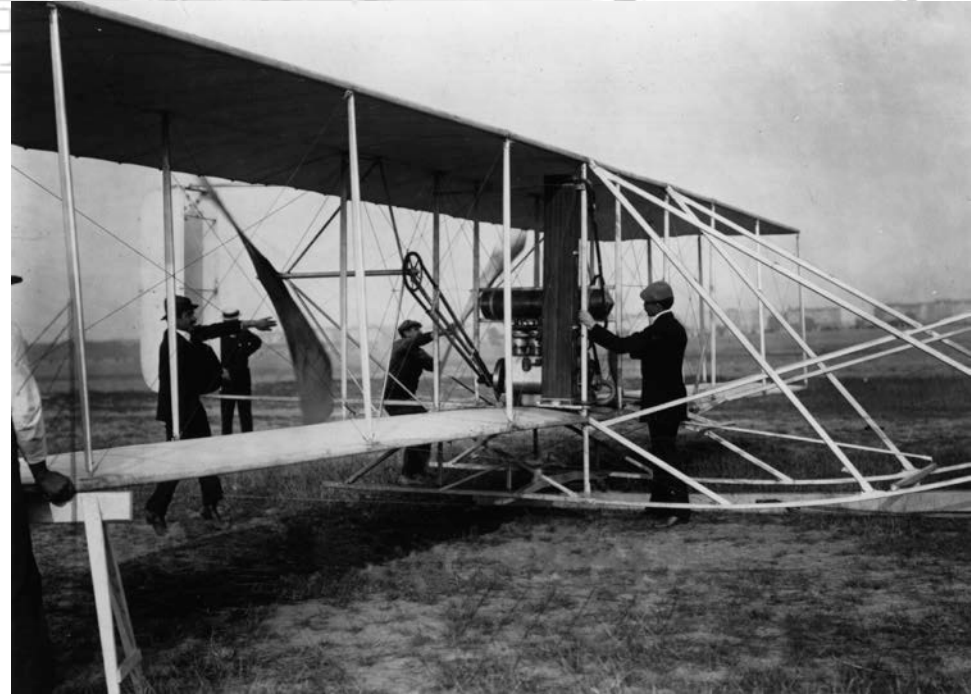

**Wright Brothers in
Berlin 1909**

Did it Themselves: Aircraft

- * **1909** British Advisory Committee on Aeronautics
- * **1915** National Advisory Committee on Aeronautics
- * 1939 NACA Ames Aeronautical Laboratory
- * **1918** WWI ends...
...**Barnstorming Begins!**
Hacked Surplus Curtiss Jenny JN-4
- * **1926** Air Commerce Act
Regulation: Safety & Licensing

Elsewhere...

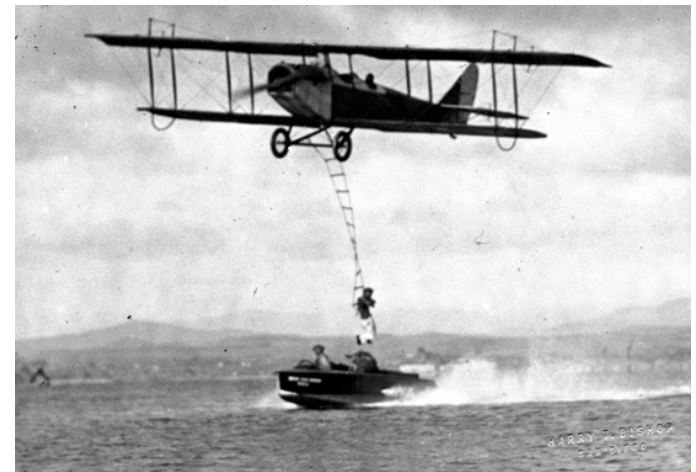

Did it Themselves: Space

- * **1920** Robert Goddard
“A Method of Reaching Extreme Altitudes”
1926 1st liquid fueled rocket launches
- * **1923** Hermann Oberth
“The Rocket into Planetary Space”

But these guys were not the first hackers trying to explore space....



Did it Themselves: Space

Humans have been exploring space...



“El Caracol” Mexico 600~800 AD

...a LONG TIME!

Did It Himself: Space

Galileo Galilei ~ the first documented space hacker.



Hand polished custom built telescope lenses

Discovered Jupiter's moons

Re-ignited interest in building observatories!

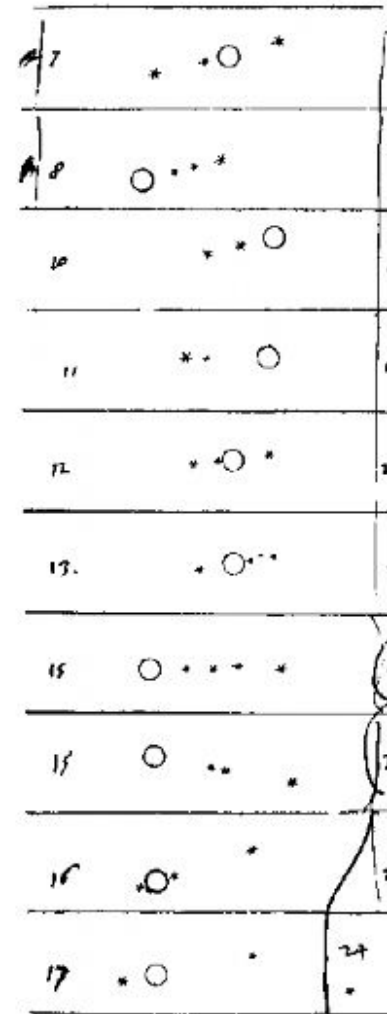

Military Space



Royal Greenwich Observatory



Leiden



Paris



Berlin

They Did It For You

* Sad Facts

- * Many of the ancient observatories were built to gain tactical advantage during wartime
- * Airplane development dramatically accelerated due to the World War I effort.
- * As we all know, World War II & the Cold War were drivers of spacecraft development as well.

Military Space

October 1957

- * **Nikolai Kutyrkin**
 - * Designed Sputnik-1

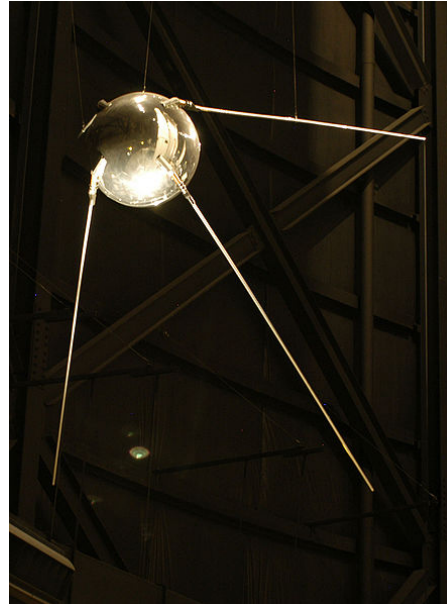

January 1958

- * **Werner Von Braun**
 - * Designed Juno-I rocket
- * **William Pickering**
 - * Designed Explorer-1

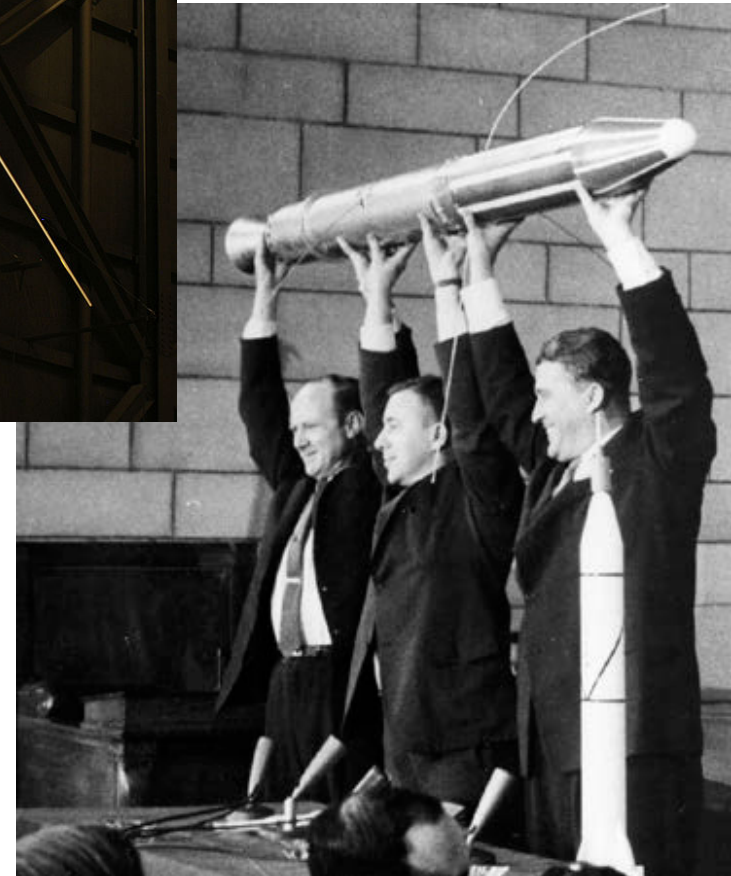

Something Better

29-July-1958

National Aeronautics & Space Administration

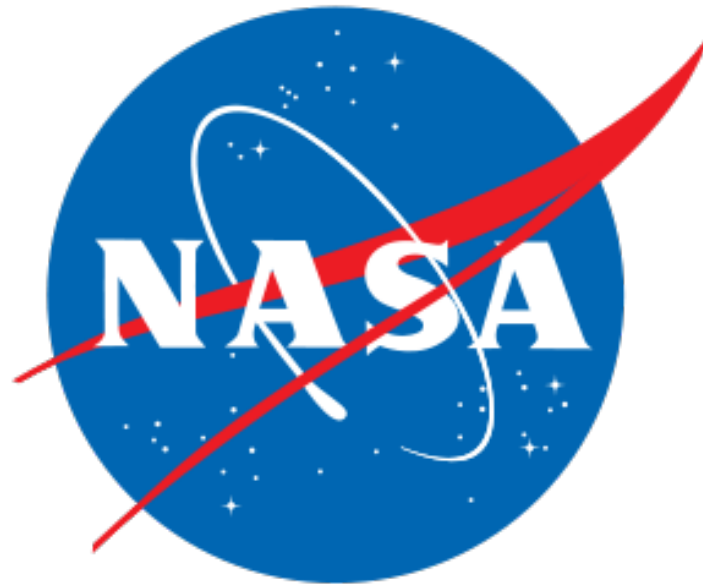

Doing It Themselves: Space



How NASA Helps Commerce

Suborbital Spaceflight (eg. Virgin Galactic, Masten Space)

Commercial ReUsable Suborbital Research program

SpaceX, Orbital Sciences

Cargo Resupply Missions

Thermal Protection Systems

Bigelow Aerospace

Space Act Agreements for Personnel chance, Procurements of inflatable modules for ISS.

Ways NASA incubates Makers

Warm-up to real business

* International Space Apps Challenge

* spaceappschallenge.org

* Center of Excellence for Collaborative

Innovation www.nasa.gov/offices/COECI



Center of Excellence for
Collaborative
Innovation

Ways NASA incubates Makers

Getting Serious

- * Small Business Innovative Research Grant
 - * sbir.gov
 - * sbir.nasa.gov

- * NASA Technology Transfer Portal
 - * technology.nasa.gov

Space Act Agreements



Home

About Us

Products

News

Store

Affordable
Access to Space™

We Offer Convenient, Affordable, On-Demand Access to Satellites. [Join the Launch!](#)

Let's Go to Space



Most Space companies think only about the mission—we think about the interaction. We create tools that make it simple for anyone to interact with Space in meaningful and enjoyable ways.

Get Started Today

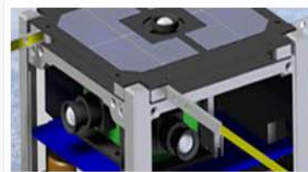

Learn to program an ArduSat Arduino kit, or go ahead and purchase time to control the satellite while running your very own application, game or experiment in Space.

Want to Learn More?

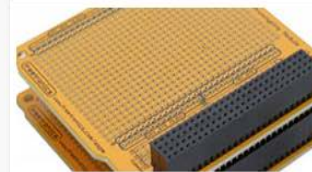

Space has inspired imaginations for centuries. Don't let any initial questions or concerns hold you back. Find your answers, or pose any additional questions here.

Non-Profit Incubator Engagement



PUBLISHED ON WEDNESDAY, FEBRUARY 13, 2013

CASIS and MassChallenge Announce Partnership to Send Entrepreneurial Research to the ISS

KENNEDY SPACE CENTER, FL. (February 13, 2013) – The Center for the Advancement of Science in Space (CASIS), the nonprofit organization promoting and managing research on board the International Space Station (ISS) U.S. National Laboratory, today announced it will provide up to \$100,000 [≈ cost of Porsche 911] in grant funding for qualified research projects as part of its partnership with the “MassChallenge Startup Accelerator.”

MassChallenge is the largest-ever startup accelerator, and the first to support high-impact, early-stage entrepreneurs without taking any equity. Its four-month program offers world-class mentorship, free office space, \$1 million [≈ 1965 typical CEO pay] in cash awards, and up to \$10 million through in-kind support. To date, MassChallenge alumni have collectively raised over \$360 million in outside funding, generated nearly \$100 million [≈ Large city office building] in revenue, and created nearly 3,000 jobs since 2010.

As per the agreement with MassChallenge, CASIS will commit up to \$100,000 [≈ cost of Porsche 911] to any winning proposal that is deemed flight-ready for research on board the ISS. CASIS funds for qualified research proposals on Station are not part of the original MassChallenge award, but are offered on top of any other grants received through the contest.

“Through the MassChallenge Startup Accelerator, we strive to provide early-stage entrepreneurs with the mentorship and funding that will allow them to succeed in today’s global economy,” said MassChallenge Director of Partnerships Scott Bailey. “We are incredibly excited to announce this partnership with CASIS, and in doing so believe we are taking our contest to the next emerging market: the ISS.”

NASA Ames SpaceShop

At NASA Ames, we're making a Fab Lab to develop the workforce, train students and eventually standardize spacecraft design

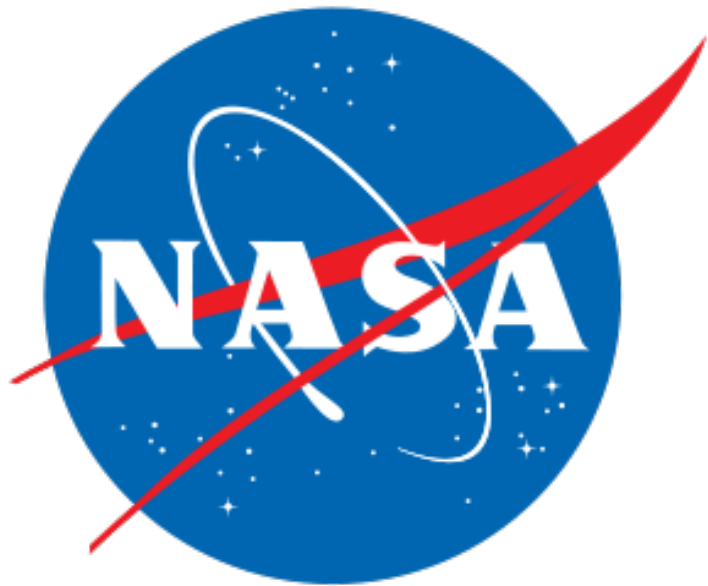

FABACADEMY

Do-It-Yourself: Space

* What is a Fab Lab?

Laser Cutter

3D Printer

Desktop Mill

Vinyl Cutter

Shop Bot

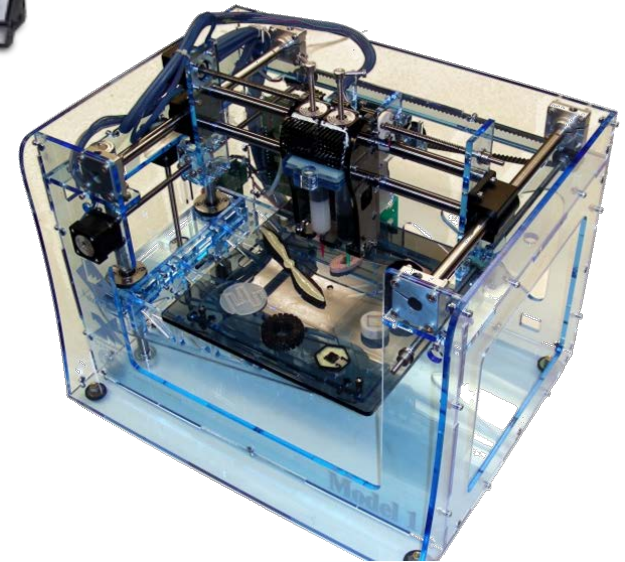

Do-It-Yourself: Space

Our goal is to make satellite construction as easy as downloading 3Dfiles to be printed, milled, & otherwise assembled into functional spacecraft.

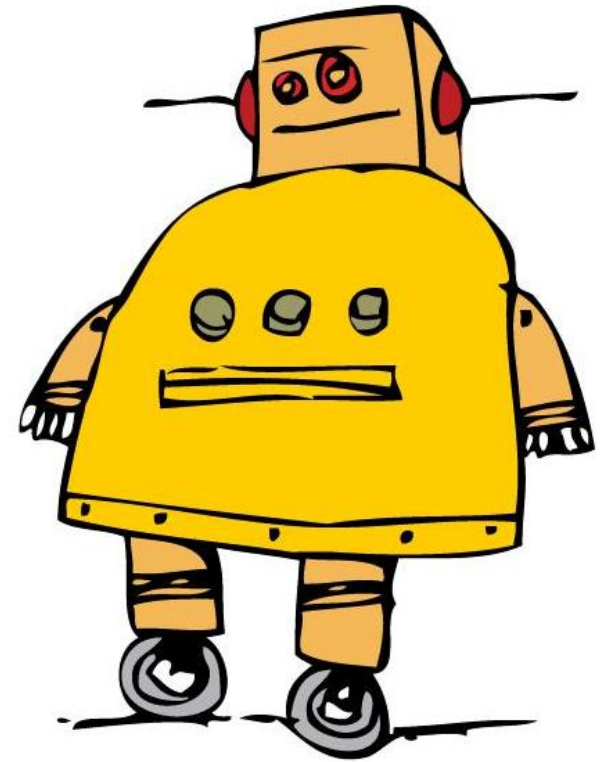

[instructables.com](https://www.instructables.com)

THE WORLD'S BIGGEST SHOW & TELL

Leveraging 3D Printing Through Innovative Design for Space Exploration

Launch Costs

Figure 1: Estimated Launch Price Per Pound for Commercial GSO Payloads (constant 2000\$)

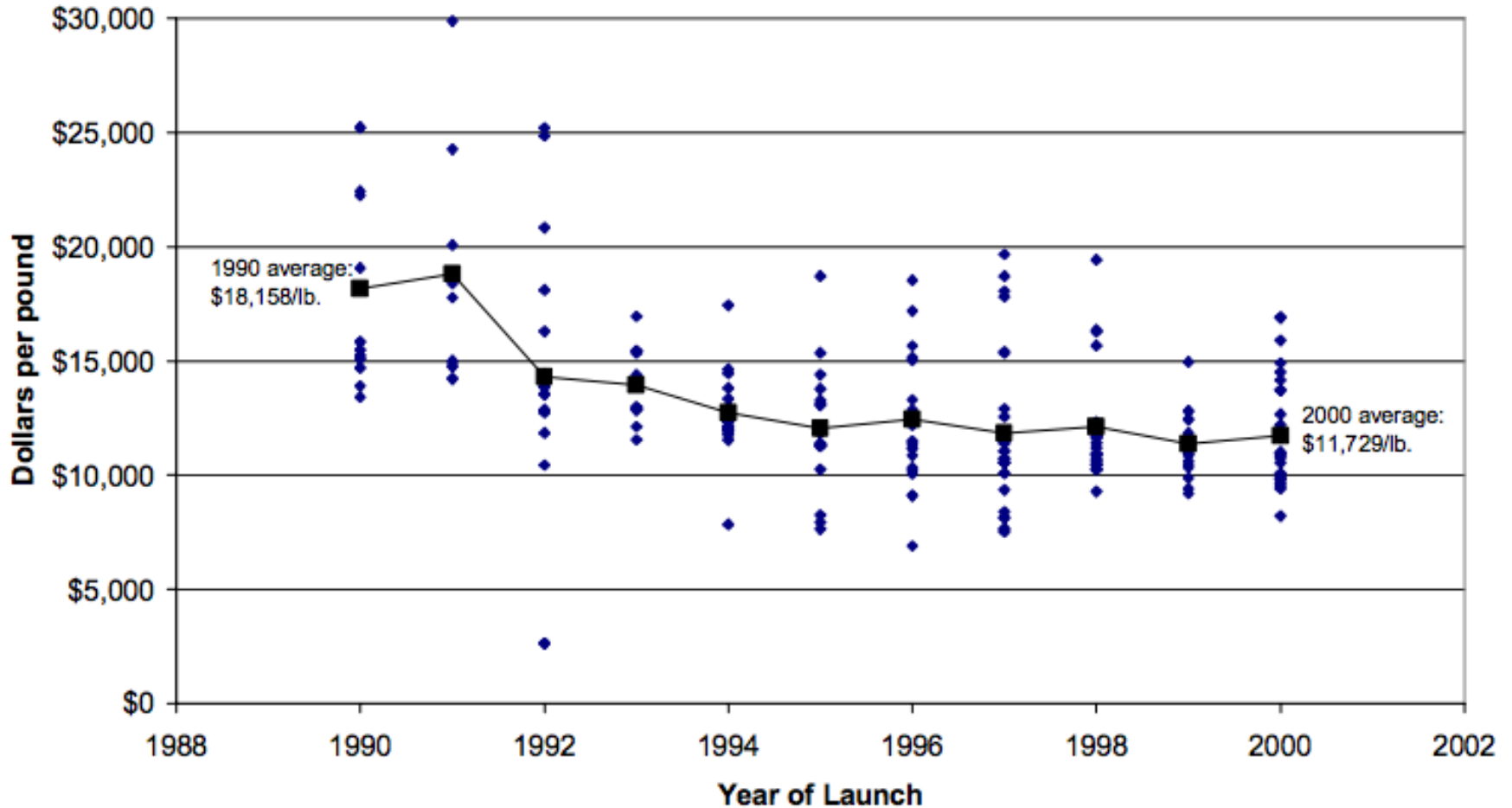

Do-It-Yourself: Space

Make:
technology on your time

Build a
Freeze Frame
Photo Rig
page 90 »

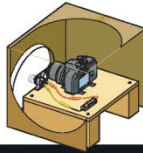

10 DO-IT-YOURSELF SPACE PROJECTS
FAST, CHEAP, AND FUN!

▶ LAUNCH YOUR OWN SATELLITE INTO ORBIT

A complex piece of hardware, including a screen, buttons, and various sensors, mounted on a metal frame. It is shown against a background of Earth from space.

PLUS:

- 26 COOL THINGS YOU CAN BUILD!
- MythBusters' Adam Savage Teaches Moldmaking
- Ping Pong Gun
- Dizzy Robot
- Analyze Galaxies for \$20: Easy Spectrograph
- ▶ Lego NXT satellite prototype built by college students and NASA

O'REILLY

makezine.com



Space Science Gadgets You Can Make for NASA

BY MATTHEW F. REYES

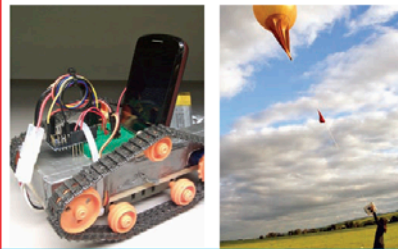

The joint cadre of volunteers at NASA Ames and Google are now hacking Android smartphone components to control robotic rovers, aerial vehicles, and small satellites, and to collect science data from them. Within a limited budget, we're relying on students and the maker community to create and program this new class of universal, open source participatory exploration platforms.

We need immediate help to develop wi-fi, Bluetooth, or USB interfaces that can connect scientific data collection payloads to devices running the Android OS. From there, there's boundless potential for makers to create previously unthinkable gadgets to support NASA's mission, including:

- ▶ "Mini-Hubble" space telescopes that can send space images to amateur astronomers
- ▶ Ruggedized "cellbots" that can explore extreme environments on Earth and on near-Earth asteroids
- ▶ Remote-sensing, environmental-sampling aerial vehicles, such as balloons and helicopters, that can help analyze climate change.

What can you imagine exploring with your smartphone? Let me know at motorbikematt@gmail.com.

Matthew F. Reyes is founder of Exploration Solutions, Inc., an education subcontractor at NASA Ames Research Center. twitter.com/motorbikematt

Do-It-Yourself: Space

Building satellites out of cellphones

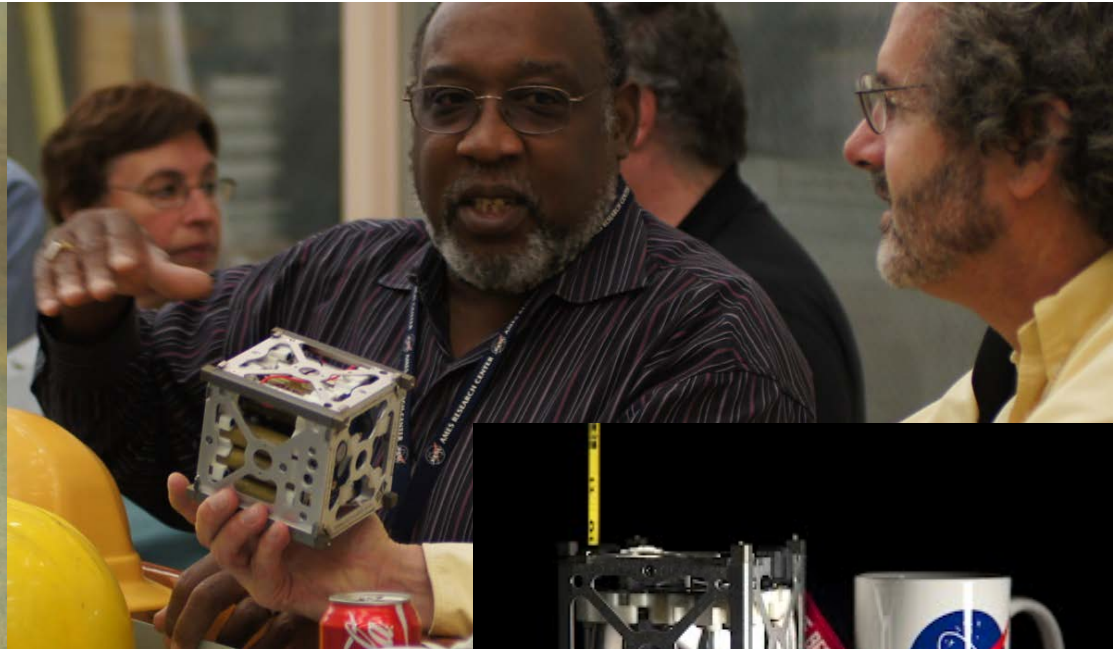

Do-It-Yourself: Space

TechEdSat

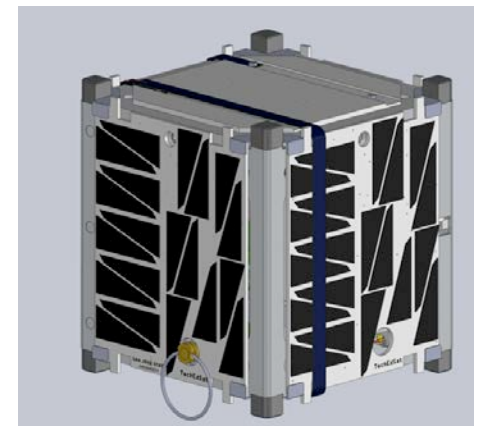
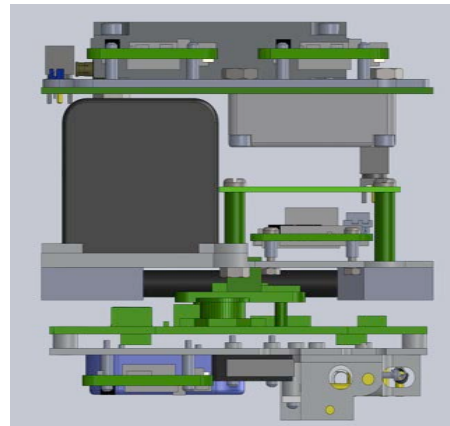
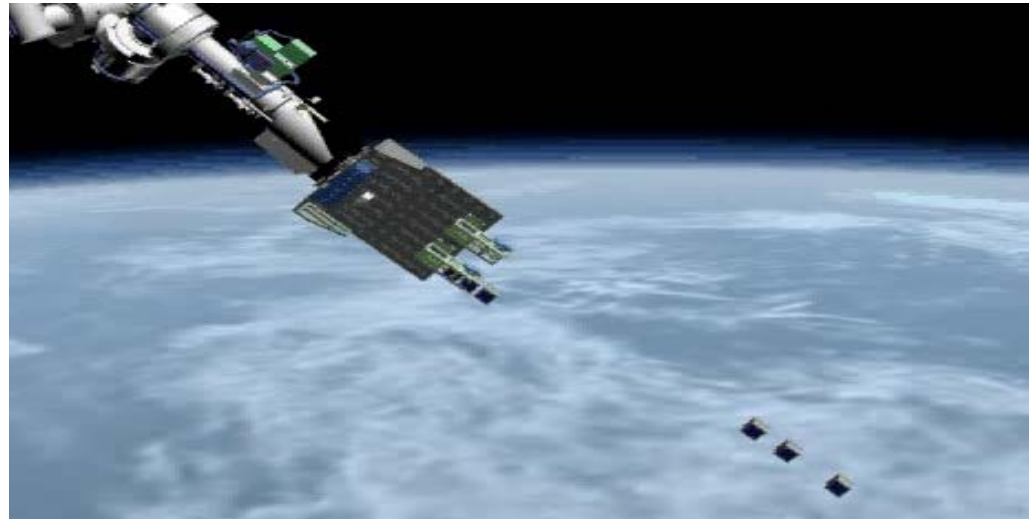
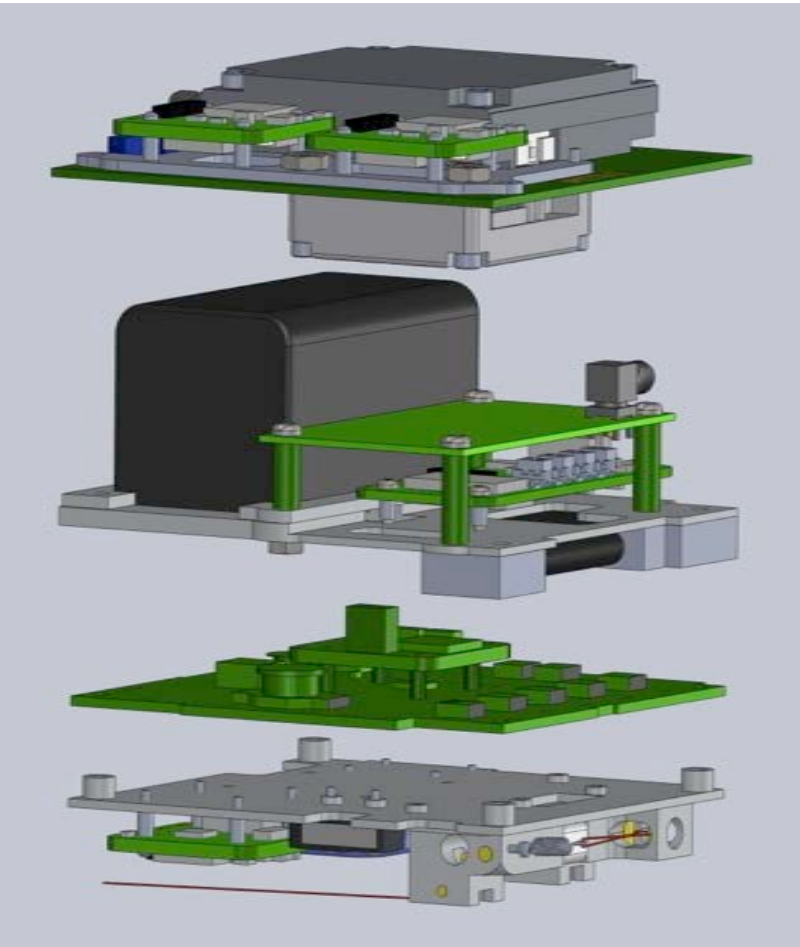

KickSat -- Your personal spacecraft in space!

by [Zachary Manchester](#)

[Home](#) [Updates](#) **18** [Backers](#) **315** [Comments](#) **26**

[Ithaca, NY](#) [Open Hardware](#)

Funded! This project successfully raised its funding goal on December 3, 2011.



[Like](#) 108 people like this. [Sign Up to see what your friends like.](#)

[Tweet](#)

[Embed](#)

<http://kickst.com/qia31Q>

Would you like to have your own spacecraft? Kickstart the personal space age by helping launch tiny spacecraft into low Earth orbit.

[Launched:](#) Oct 4, 2011

[Funding ended:](#) Dec 3, 2011



Would you like to have your own spacecraft in space?

I'm Zac Manchester, a graduate student in Aerospace Engineering at Cornell University. Over the last several years a few collaborators and I have

315

backers

\$74,587

pledged of \$30,000 goal

0

seconds to go



Project by
Zachary Manchester
Ithaca, NY
[Contact me](#)

[First created](#) - 0 backed

[Zac Manchester](#) (306 friends)

[Website: http://spacecraftresea...](http://spacecraftresea...)

[See full bio](#)

Pledge \$25 or more

67 Backers

Your name on one of KickSat's panels that will fly into space

Est. delivery: Jan 2013

Do-It-Yourself: Space

ArduSat - Your Arduino Experiment in Space

by [ppl4world](#)

Home Updates **11** Backers **676** Comments **74**

San Jose, CA Open Ha

Funded! This project successfully raised its funding goal on July 15.

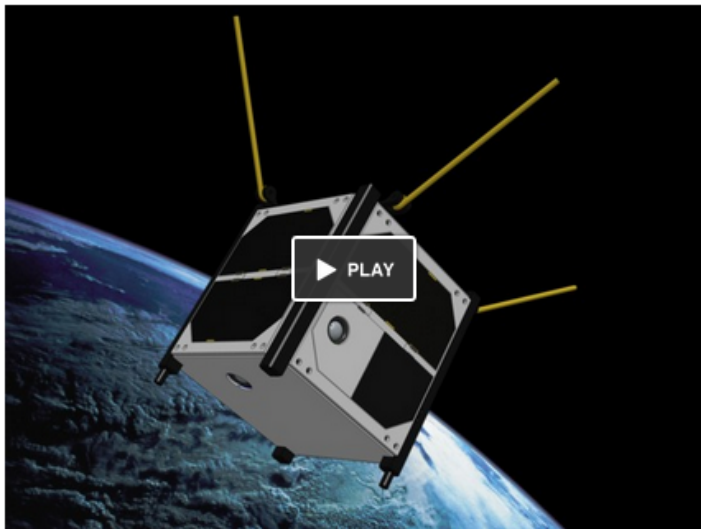

676
backers
\$106,330
pledged of \$35,000 goal
0
seconds to go



Project by
ppl4world
San Jose, CA
Contact me

First created - 5 backed

Has not connected Facebook

Website: <http://facebook.com>

[See full bio](#)

Pledge \$1 or more

130 Backers

SkyCube: The First Satellite Launched by You!

by [Tim DeBenedictis](#)

Home Updates **6** Backers **1,477** Comments **49**

San Francisco, CA Technology

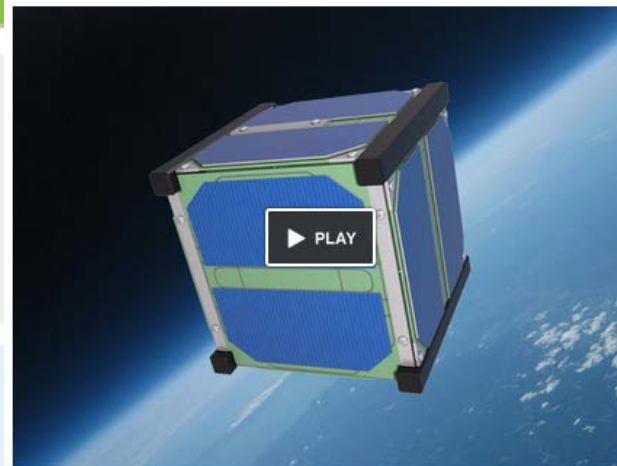

1,477
backers
\$58,892
pledged of \$82,500 goal
17
days to go

Back This Project
\$1 minimum pledge

This project will only be funded if at least \$82,500 is pledged by Wednesday, Sep 12, 3:02am EDT. [How Kickstarter works.](#)



Project by
Tim DeBenedictis
San Francisco, CA
Contact me

First created - 8 backed

Tim SkyCube DeBenedictis
(350 friends)

Website: <http://southernstars.com>

[See full bio](#)

Pledge \$1 or more

157 Backers

10,207 people like this. Sign Up to see what your friends like.

Tweet

Embed

<http://kck.st/1M8nEEK>

A nano-satellite that lets you take Earth images and "tweet" from space, then inflates a visible balloon, and de-orbits cleanly.

Launched: Jul 14, 2012

Funding ends: Sep 12, 2012

Remind me

We want to create a space exploration experience that can be shared by everyone - including you!

[¡Ver aquí en español!](#)

[Lesen Sie mehr über SkyCube in deutscher Sprache!](#)

[Cliquez ici pour en apprendre davantage sur SkyCube en français!](#)

[Clicca qui per conoscere SkyCube in italiano!](#)

We love Arduino and we love space exploration. So we decided to combine them and let people run their own space experiments!

Launched: Jun 15, 2012

Funding ended: Jul 15, 2012



UPDATE: Help us break the 100k barrier! So join us now!

Do-It-Yourself: Space

And oh by the way..

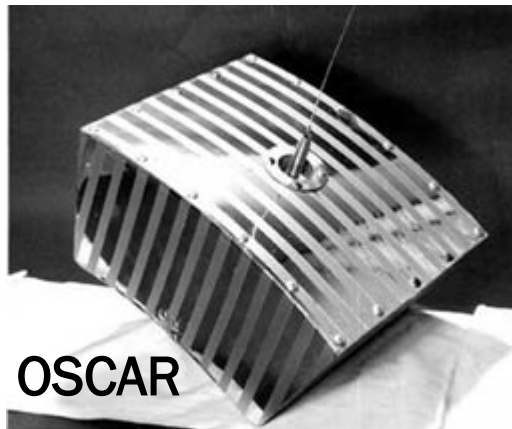

Launched in 1961

Still not new...

21 Countries,
Dozens of satellites



Do-It-Yourself: Space

**Space Technology
isn't always in orbit**

Do-It-Yourself: Space

Space isn't always up..

Western Australia



Do-It-Yourself: Space

United Arab Emirates
Arabian Peninsula

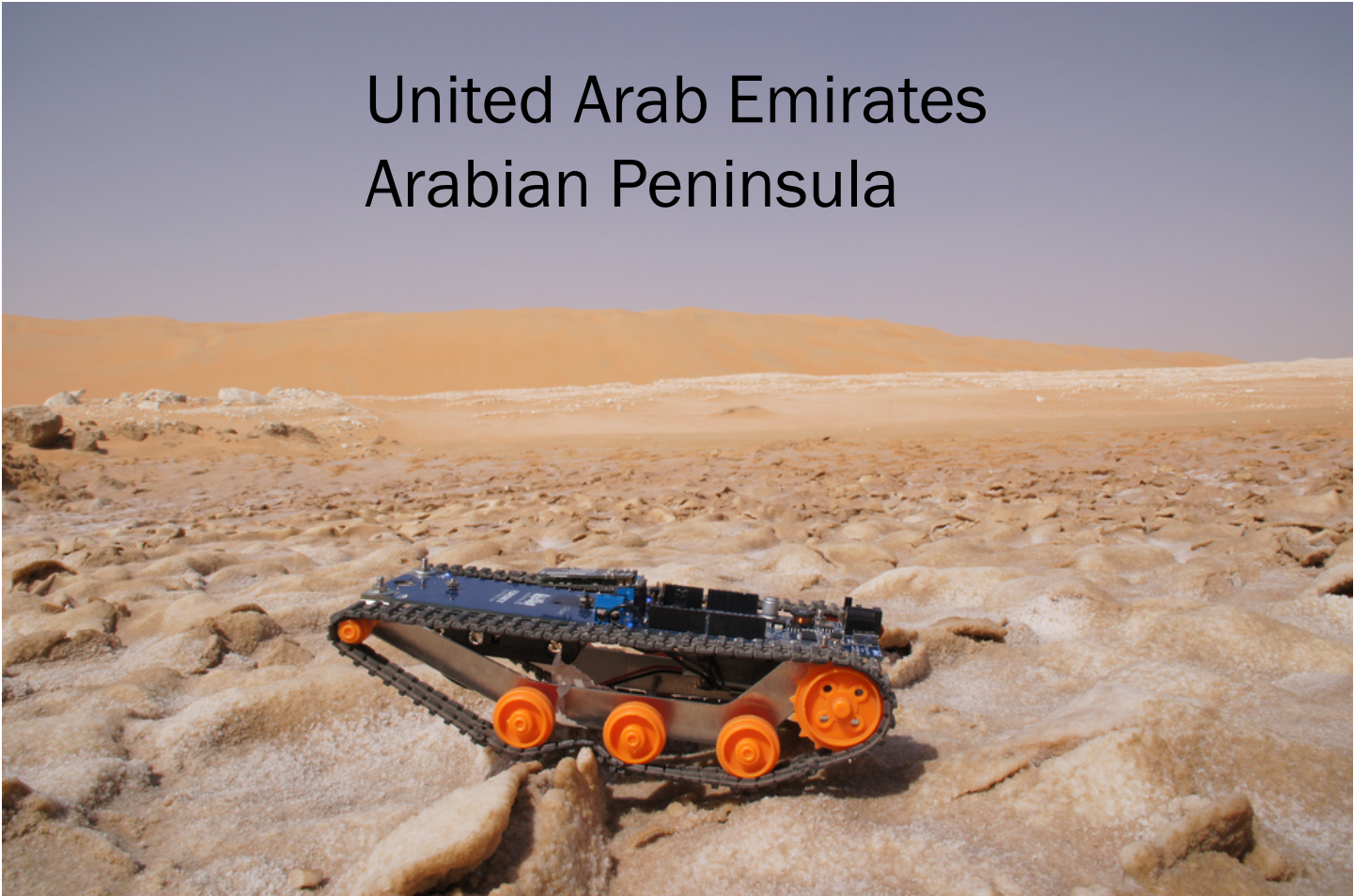

Do-It-Yourself: Space



UAE



Mars



Namibia

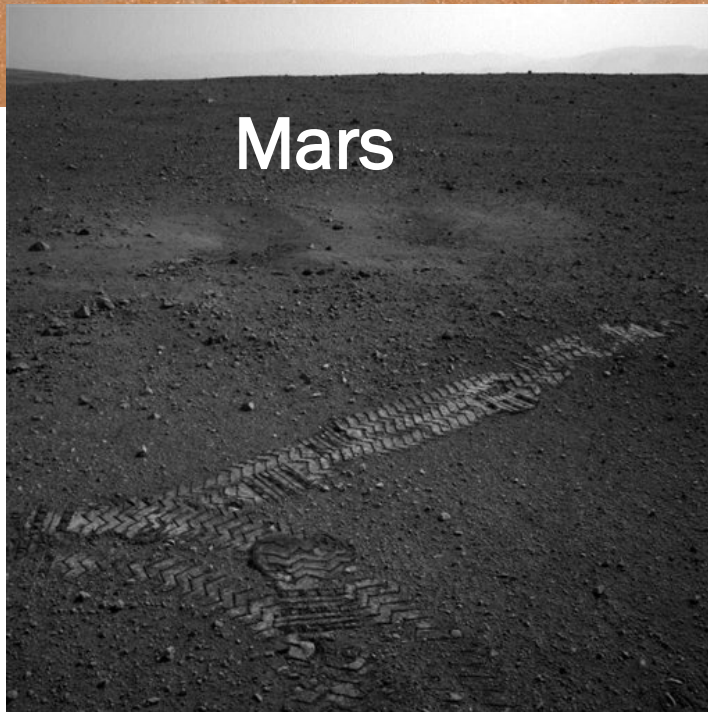

Mars

Do-It-Yourself: Space

