



## Alternatives for Primary Frequency Control Contribution from Wind Power Plants Connected to VSC-HVDC Inertia

Laukhamar, Andreas Grøsvik ; Zeni, Lorenzo; Sørensen, Poul Ejnar

*Publication date:*  
2014

[Link back to DTU Orbit](#)

*Citation (APA):*

Laukhamar, A. G., Zeni, L., & Sørensen, P. E. (2014). Alternatives for Primary Frequency Control Contribution from Wind Power Plants Connected to VSC-HVDC Inertia. Poster session presented at European Wind Energy Conference & Exhibition 2014, Barcelona, Spain.

## DTU Library

Technical Information Center of Denmark

---

### General rights

Copyright and moral rights for the publications made accessible in the public portal are retained by the authors and/or other copyright owners and it is a condition of accessing publications that users recognise and abide by the legal requirements associated with these rights.

- Users may download and print one copy of any publication from the public portal for the purpose of private study or research.
- You may not further distribute the material or use it for any profit-making activity or commercial gain
- You may freely distribute the URL identifying the publication in the public portal

If you believe that this document breaches copyright please contact us providing details, and we will remove access to the work immediately and investigate your claim.

# Alternatives for Primary Frequency Control Contribution from Wind Power Plants Connected to VSC-HVDC Intertie

Andreas Grøsvik Laukhamar<sup>1,\*</sup>, Lorenzo Zeni<sup>2,3</sup>, Poul Ejnar Sørensen<sup>3</sup>

<sup>1</sup>Department of Automation and  
Electrical Systems  
Ramboll Denmark

<sup>2</sup>Electrical System  
Analysis Department  
DONG Energy Wind  
Power

<sup>3</sup>Department of Wind  
Energy  
Technical University of  
Denmark

\*Correspondence to: Hannemanns Allé 53, 2300 Copenhagen S, Denmark,  
AGL@ramboll.com, +45 516 18 914

## Summary

With the increasing share of renewables in the electric power systems, the transmission system operators (TSOs) need more balancing power to even out short- and long-term variability of the intermittent electric power sources such as solar and wind power. In light of this, this paper investigates how a large offshore wind power plant (OWPP) with high voltage direct current (HVDC) intertie connection to two asynchronous onshore AC power systems can be part of the solution in providing short-term mutual active power balancing.

The primary frequency control is investigated for four different study cases. Both a centralized and distributed DC voltage control strategy have been successfully implemented, each with two communication methods: either direct AC frequency communication to the OWPP or coordinated control of onshore AC frequencies and onshore DC voltages, then communicating the offshore DC voltage to the OWPP.

Independent of the communication method, the implemented distributed DC voltage control has proven to provide a superior frequency stability and limitation of the maximum deviation in onshore AC frequencies during large load events. This control strategy results in a sharing of the primary reserves and rolling inertia between the two onshore AC power systems connected to the HVDC intertie, whilst also exploiting the OWPP in the primary frequency control scheme.

## Introduction

As a consequence of the somewhat unpredictable presence of wind and solar radiation, a higher share of renewables in the electric power systems increases the demand of balancing power reserves (primary, secondary and tertiary capacities) to maintain security of electric energy supply [1]. When considering wind, a measure that limits the need for reserves in normal operating conditions is to build the wind power plants (WPPs) at offshore rather than onshore sites, as offshore sites tend to have stronger and more stable wind conditions.

In the Nordic region, it is widely recognized that the future wind power development will to a large extent be offshore [2]. The technically most promising technology for connection of remote WPPs is the voltage source converter based high voltage direct current (VSC-HVDC) [3]. This paper addresses the control of VSC-HVDC and an OWPP connected thereto, with the objective of providing primary frequency support to the onshore AC power systems interfacing an HVDC intertie. A new method for communication and control that facilitates wind power participation in the primary frequency control through an HVDC intertie is proposed.

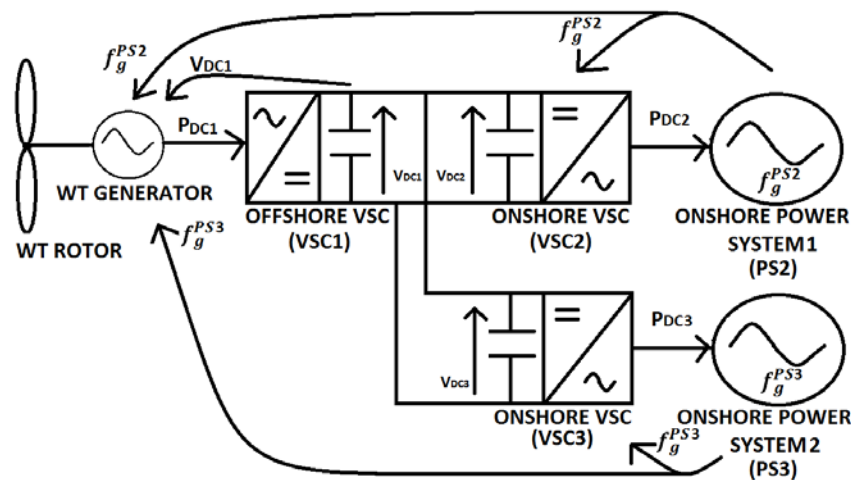

**Figure 1.** Sketch of the VSC-HVDC intertie with communication schemes

## Approach

The three-node HVDC system in Figure 1 has been modeled in Matlab Simulink to study the dynamical response of onshore AC frequencies, DC voltages and DC power flows when either one of the onshore AC power systems connected to the HVDC intertie is subjected to a generation or load disturbance. An illustration of the block diagram model with the different systems, controllers and communication schemes is presented in Figure 9 in the Appendix. The level of detail in the modelling is chosen adequately to the targeted simulations. Its detailed description and verification was done in “Control of Offshore Wind Power Plant with HVDC Grid Connection” by A. Laukhamar. The two onshore systems are assumed to be identical and the main modelling data are reported in Table 1 in the Appendix. In the following simulations, the incoming wind speed is assumed to be constant while the disturbance is caused by the loss of a large generation unit in each of the onshore AC power systems (first PS2 and then PS3) within a time period of 50 seconds.

In order for the WPP to participate in the primary frequency control in case of under-frequency events occurring in the onshore AC power systems, the WPP has to be deregulated to release part of its capacity. In this study, the primary reserve capacity provided by the WPP corresponds to 20 % of the wind turbines’ maximum power point tracking (MPPT) power reference. The requirements used in this study for the regulation of this released capacity are the GCR valid for larger thermal power plants that are connected to the grid in Western Denmark [4]. Consequently, the WPP is obligated to provide its complete primary reserve as from frequency deviations of 200 mHz from the nominal value 50 Hz.

The DC connection decouples the three frequencies of the two onshore AC power systems and the power collection grid in the OWPP. Therefore, a frequency disturbance in one of the AC power systems will not inherently be supported by speed governors in the other AC power system or by a frequency controller for the WPP. A mutual AC frequency support can, however, be achieved by means of communication links, coordination of AC frequencies and DC voltages or a combination of these two methods. This paper investigates both a direct AC frequency communication to the WPP as well as a coordinated droop control of onshore AC frequencies and onshore DC voltages, where the offshore DC voltage is communicated to the WPP's primary frequency controller.

Besides investigating different communication methods and their influence in a system perspective, the HVDC grid is investigated for two control methodologies referred to as centralized and distributed DC voltage control. The combination of these communication and HVDC grid control methods form the study cases investigated in this paper. Study cases and associated control configuration of each converter are described in Table 2 in the Appendix, while the different configurations of the DC voltage controller are illustrated in Figure 2-4.

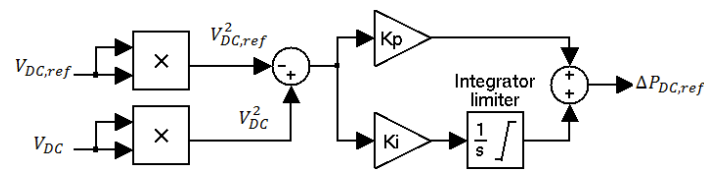

**Figure 2.** Centralized DC voltage control with fixed onshore DC voltage reference

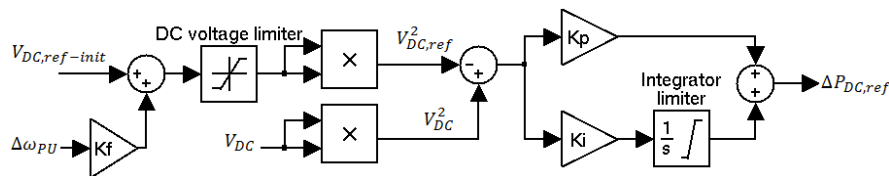

**Figure 3.** Centralized DC voltage control with coordinated control of onshore AC frequency and onshore DC voltage

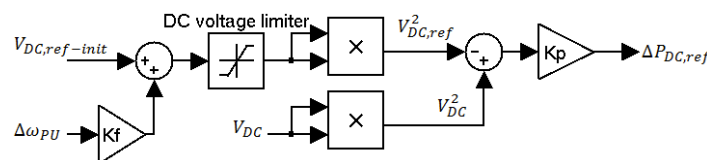
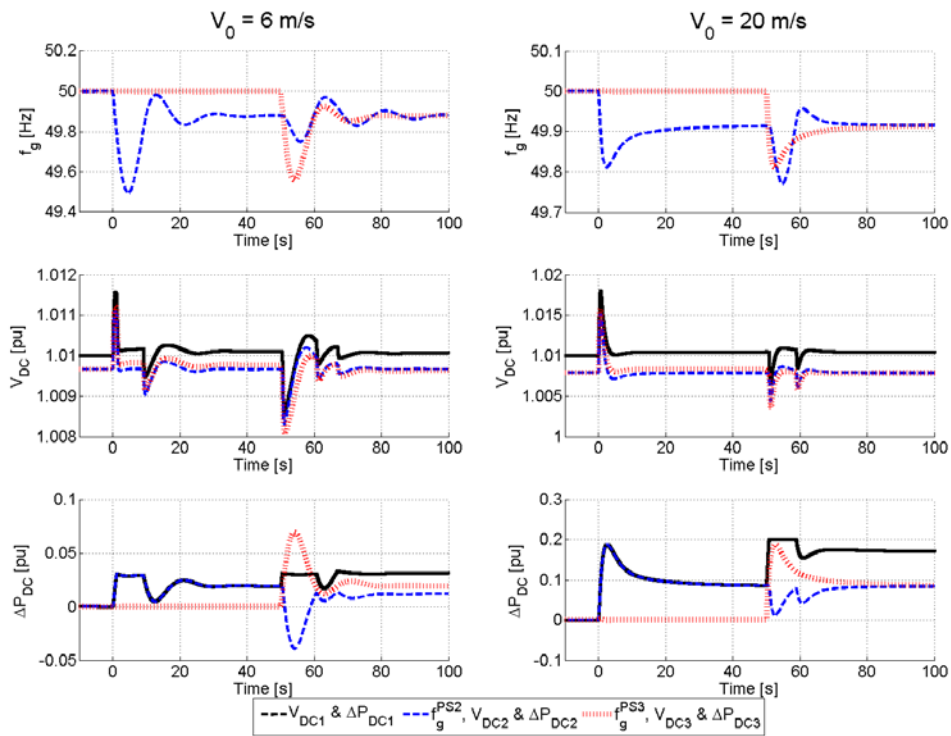

**Figure 4.** Distributed DC voltage control with coordinated control of onshore AC frequencies and onshore DC voltages

### Simulation results

Figure 10 in the Appendix presents the onshore AC frequency response of either system, when neither the OWPP nor the other onshore AC power system is participating in the primary frequency control. For the following responses in onshore AC frequencies, this response is considered the base case.

As the aerodynamic power is given by the cube of the wind speed and the primary reserve capacity provided by the WPP is 20 % of the MPPT power reference, the wind power contribution in primary frequency control is highly dependent on the incoming wind speed. Therefore, to accentuate the effects of this variable contribution, each of the four study cases presented in Table 2 are simulated for a wind speed in the lower optimization zone and upper limitation zone of a variable speed wind turbine.



**Figure 5.** Study case 1: Centralized DC voltage control with onshore AC frequency communication links to the OWPP (VSC1=Power controller, VSC2=DC voltage controller, VSC3=Power controller)

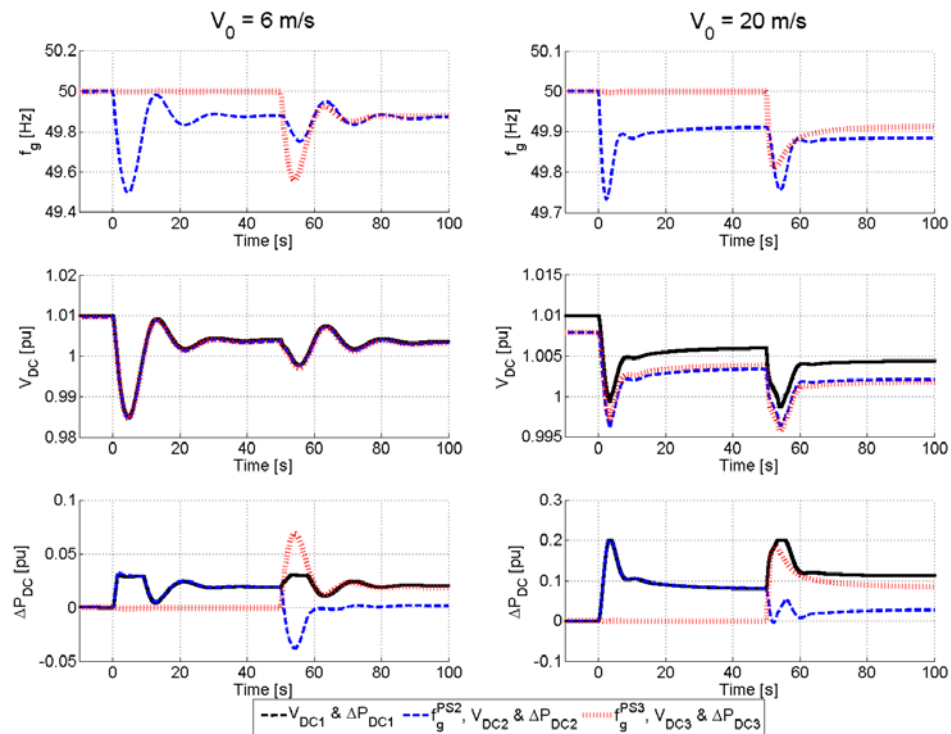

**Figure 6.** Study case 2: Centralized DC voltage control with offshore DC voltage communication link to the OWPP (VSC1=Power controller, VSC2=DC voltage controller, VSC3=Power controller)

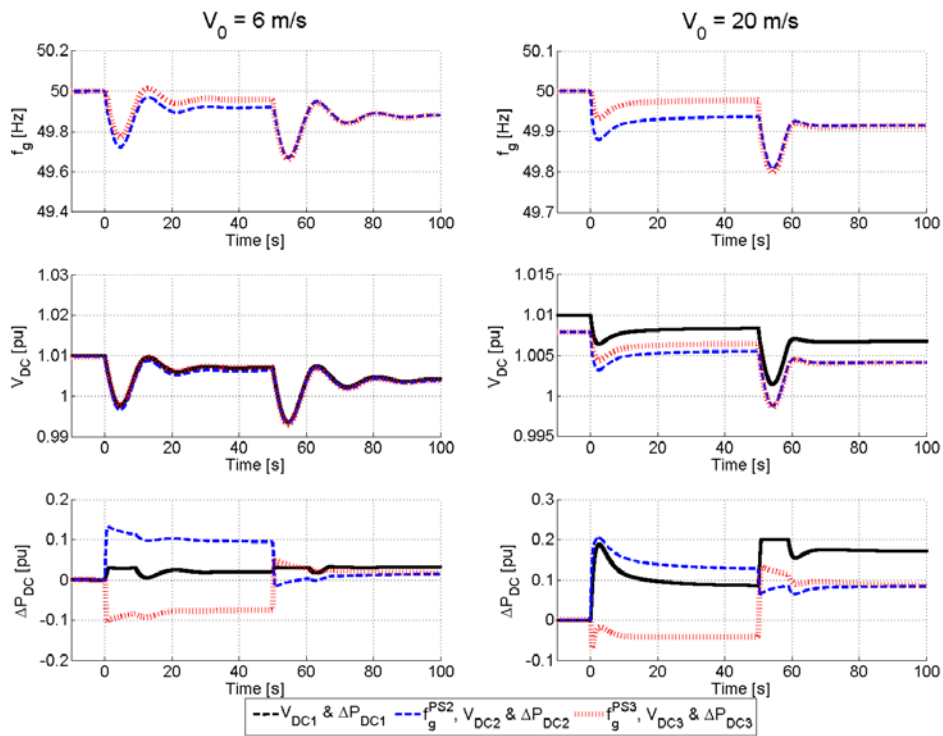

**Figure 7.** Study case 3: Distributed DC voltage control with AC frequency communication links to the OWPP (VSC1=Power controller, VSC2=DC voltage controller, VSC3=DC voltage controller)

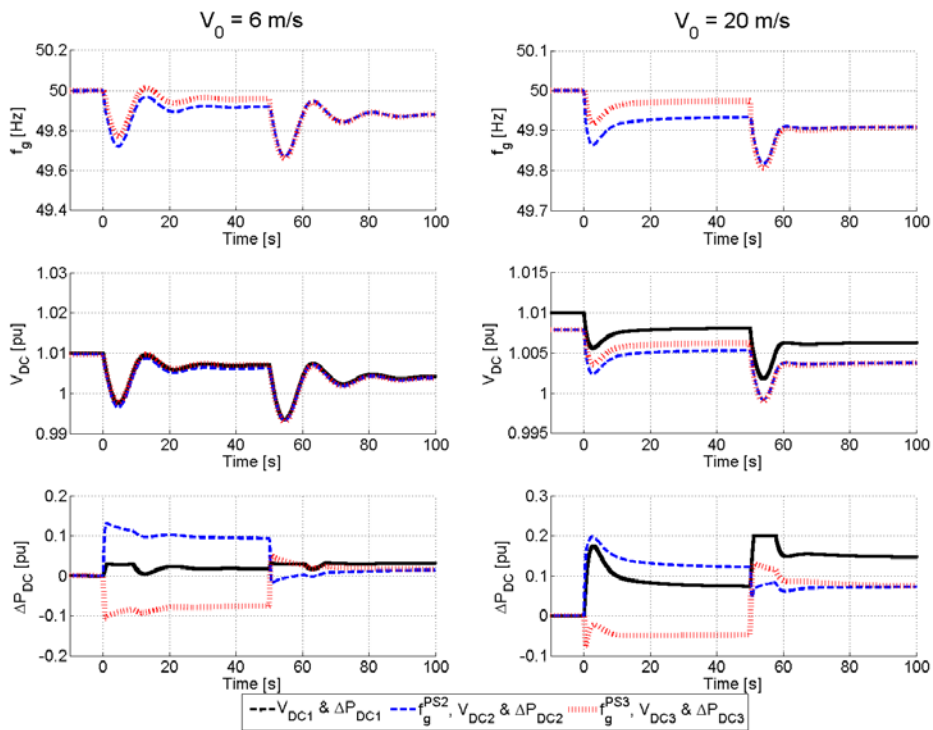

**Figure 8.** Study case 4: Distributed DC voltage control with offshore DC voltage communication link to the OWPP (VSC1=Power controller, VSC2=DC voltage controller, VSC3=DC voltage controller)

## Discussion

When comparing the responses in onshore AC frequencies in Figure 5-8 with the response in Figure 10 (without contribution from the WPP and the undisturbed onshore AC power system), the convenient effects of the additional support schemes in primary frequency control are evident. Depending on the DC voltage control strategy of the HVDC grid, the method of communicating the state of the onshore AC frequencies to the OWPP and the location of the load change, the improvement varies with respect to lowering the maximum deviation in onshore AC frequencies from the nominal value and increasing the damping of the electromechanical oscillations.

By only assigning one of the onshore VSCs as a proportional integral (PI) DC voltage controller (referred to as centralized DC voltage control with a master VSC controlling the DC voltages), the mutual AC frequency support with sharing of rolling inertia and primary reserve capacity is not an inherent response. Nevertheless, in cases where an AC frequency disturbance occurs in the system interfacing the onshore power controlled VSC, the master VSC will automatically support this system by reducing the amount of power it inverts. This results in a load change in the undisturbed AC system interfacing the master VSC (PS2), as illustrated in Figure 5 and 6 at the second tripping event. Such asymmetrical power flow control in an HVDC intertie connection during load events is considered to be a more appropriate control strategy when the HVDC system interconnects the OWPP with a larger synchronous area and a smaller and weaker system. This way the stiffer system can contribute to increasing the AC frequency stability and reduce the maximum onshore AC frequency deviation in the weaker system. The latter argument reduces the risk of protective under-frequency tripping events of thermal power plants, which possibly can lead to cascade outages, and the need to perform load shedding [5]. Besides the grid strength, other factors of influence are costs and flexibility of balancing reserves.

Considering the centralized DC voltage control of the particular system studied, the difference in onshore AC frequency responses between the communication methods are due to the following. The time delay associated with the OWPP's primary frequency controller is considered twice as high for offshore DC voltage communication scheme, as it requires two metering and communication processes compared to the single process of direct AC frequency communication. Since the power reference of the power controlled onshore VSC (VSC3) remains unchanged during load changes in the other system (PS2), the additional time delay associated with the offshore DC voltage communication method results in a maximum deviation in onshore AC frequency of 49.73 Hz compared to 49.81 Hz when using direct AC frequency communication. Additionally, for load events occurring in the AC system interfacing the power controlled onshore VSC, the offshore DC voltage communication method also results in a wind power contribution less than the minimum requirements of the reference GCR. This is a consequence of only having the master VSC controlling the DC voltages, which means the state of the onshore AC frequency of the system interfacing the power controlled VSC is not reflected in the state of the offshore DC voltage.

Independent of the two communication methods, a distributed DC voltage control strategy manages to reflect the state of both onshore AC frequencies in the offshore DC voltage by means of coordinated droop control of the onshore DC voltages with the interfacing onshore AC frequencies. The corresponding simulation results prove this control method to result in a symmetrical or close to symmetrical power flow in the HVDC intertie during load events in either of the onshore AC power systems. Another result of this control strategy is the mutual share of rolling inertia and primary reserve capacity between the two onshore AC power systems, without the need of long-distance communication links. Independently of where a load event occurs, the load change is shared between the two onshore AC power systems as a result of the DC power flow demand control performed by the onshore VSCs' DC controller. This proves beneficial in terms of increased damping of the electromechanical oscillations and reducing the maximum deviation in onshore AC frequencies from the nominal value, particularly in times when the WPP holds a low primary reserve capacity due to a low mean wind speed.

In periods of time with wind speeds in the wind turbines' limitation zone, the simulation results prove that a WPP with 12.4 % system penetration share and operated at 20 % power curtailment can be a valuable asset in the primary frequency control. Due to the WPP's capability of quickly regulating its primary reserve capacity, the maximum deviations in onshore AC frequency are significantly reduced and the onshore AC frequencies are faster brought to their new steady-state value. With some additional support from the other onshore AC power system, the lower peak in the onshore AC frequency is reduced to 49.89 Hz (distributed DC voltage control with AC frequency communication) from 49.41 Hz (without frequency support from the HVDC system or WPP).

In contrast to the responses at high wind speeds, the active power support is mainly provided by the supporting onshore AC power system when the incoming wind speed is in the lower end of the wind turbines' operational range. Besides looking at the delta DC power flows, this is also evident when comparing the onshore AC frequency responses during the first load event at low wind speed in Figure 5 (frequency support from the WPP) with the similar responses in Figure 7 and 8 (frequency support from both the WPP and the undisturbed onshore AC power system). In Figure 5 at low wind speed, the first lower peak occurs at 49.52 Hz while the same response in Figure 7 corresponds to a lower peak of 49.73 Hz. However, the mutual AC frequency support scheme presented in Figure 7 and 8 comes at the cost of disturbing the onshore AC frequency in both systems, regardless of whether the load event occurs in one or the other system.

Apart from study case 1 (centralized DC voltage control with fixed DC voltage reference and direct AC frequency communication to the OWPP), an adverse effect of the investigated control and communication schemes is the suboptimal operational point in DC voltages following a frequency disturbance. The new steady-state DC voltages are slightly offset from their initial operating value, which is a result of having the onshore VSCs regulating the DC voltage at their node by means of a DC voltage/AC frequency droop controller. Unless otherwise integrated into the VSC DC voltage controllers (e.g. DC grid secondary controller), the DC voltages will not rise to their nominal set point before the onshore AC frequencies are fully restored to their nominal value.

## **Conclusion**

A model of an HVDC intertie interconnecting an OWPP with two asynchronous onshore AC power systems has been constructed and simulated to investigate four different methods for supplementary primary frequency support in such systems. Through a comparative analysis of the simulation results, pros and cons have been identified and discussed for different HVDC grid control and OWPP primary frequency control communication method.

When comparing the two investigated HVDC grid control strategies, the specific distributed DC voltage control proves to contribute more in the primary frequency control than the investigated methods of centralized DC voltage control. In the study cases with distributed DC voltage control, the load change is shared by both the onshore AC power systems and the OWPP. This is independent of the communication method and the location of the load event. In contrast to a centralized DC voltage control, the distributed DC voltage control results in a symmetrical mutual AC frequency support during load events. Besides this, further improvements are significant reduction in maximum deviation in onshore AC frequency and, in particular for periods with low wind speeds, the onshore AC frequencies are faster restored to a new steady-state value.

Depending on structure of the HVDC grid, the use of mutual AC frequency support strategy can allow the TSOs to reduce the primary reserves capacities in the individual AC power systems, as the individual systems are sharing load changes and thus also the short-term balancing resources. Whilst meeting the same reliability criteria, this can result in more efficient use of energy resources and, consequently, reduce the cost of energy. The control strategy, however, comes at the expense of disturbing the onshore AC frequency of each system interconnected to the HVDC grid for a single load event, even though the onshore AC power systems are electrically decoupled by the HVDC system.



## References

1. B. Droste-franke, B. P. Paal, C. Rehtanz, D. U. Sauer, J.-P. Schneider, M. Schreurs, and T. Zieseimer, *Balancing Renewable Electricity*, vol. 2012, no. February 2012. Bad Neuenahr-Ahrweiler: Springer Verlag, 2012.
2. J. Moccia and A. Arapogianni, "Pure Power - Wind energy targets for 2020 and 2030," Brussels, 2011.
3. P. Sandeberg and L. Stendus, "Large scale Offshore Wind Power Energy evacuation by HVDC Light ®," 2008.
4. K. Christensen, J. P. Kjærgaard, P. Lund, F. B. Olesen, C. Strunge, and S. F. Jensen, "Technical Regulation for Thermal Power Station Units of 1 . 5 MW and higher," Fredericia, 2008.
5. N. J. Balu, M. G. Lauby, and Electric Power Research, Eds., *Power System Stability And Control by Prabha Kundur*. Toronto, Ontario: McGraw-Hill, Inc, 1994.

## Appendix

Value	Unit	Description
2000	<i>MW</i>	Onshore generation capacity before tripping event
1560	<i>MW</i>	Initial electrical load
200	<i>MW</i>	Loss of generation capacity at $t = 0$ [s] and $t = 50$ [s]
120	<i>MW</i>	Load change/loss of generation due to tripping event
240	<i>MW</i>	Available up-regulation capacity in the onshore AC power system after tripping event
14.25	<i>pu</i>	Angular momentum after tripping event
0.39	<i>pu</i>	Composite load damping constant
4	%	Equivalent droop regulation constant of the onshore AC power system
2	%	Wind power penetration felt by the onshore AC power system at $V_0 = 6$ [ $m s^{-1}$ ], full load and equal power flow in the HVDC grid
12.4	%	Wind power penetration felt by the onshore AC power system at $V_0 = 20$ [ $m s^{-1}$ ], full load and equal power flow in the HVDC grid

**Table 1.** Key operational parameters for each of the onshore AC power systems

<b>VSC #</b>	<b><u>Study case 1</u></b> <i>- Centralized DC voltage control - AC frequency communication</i>	<b><u>Study case 2</u></b> <i>- Centralized DC voltage control - DC voltage communication</i>
1 (WPP)	Power controlled VSC Injects additional/less power into the HVDC grid as a function of the onshore AC frequencies	Power controlled VSC Injects additional/less power into the HVDC grid as a function of the offshore DC voltage
2 (PS2)	PI DC voltage controlled VSC Injects/extracts additional/less power from the HVDC grid to maintain its fixed DC voltage reference	PI DC voltage controlled VSC Injects/extracts additional/less power from the HVDC grid to maintain its DC voltage reference, which is a function of the onshore AC frequency in PS2
3 (PS3)	Power controlled VSC Injects/extracts additional/less power from the HVDC grid to provide its power reference, which is a function of the onshore AC frequency in PS3	Power controlled VSC Injects/extracts additional/less power from the HVDC grid to provide its power reference, which is a function of the onshore AC frequency in PS3
<b>VSC #</b>	<b><u>Study case 3</u></b> <i>- Distributed DC voltage control - AC frequency communication</i>	<b><u>Study case 4</u></b> <i>- Distributed DC voltage control - DC voltage communication</i>
1 (WPP)	Power controlled VSC Injects additional/less power into the HVDC grid as a function of the onshore AC frequencies	Power controlled VSC Injects additional/less power into the HVDC grid as a function of the offshore DC voltage
2 (PS2)	DC voltage controlled VSC Injects/extracts additional/less power from the HVDC grid to maintain its DC voltage reference, which is a function of the onshore AC frequency in PS2	DC voltage controlled VSC Injects/extracts additional/less power from the HVDC grid to maintain its DC voltage reference, which is a function of the onshore AC frequency in PS2
3 (PS3)	DC voltage controlled VSC Injects/extracts additional/less power from the HVDC grid to maintain its DC voltage reference, which is a function of the onshore AC frequency in PS3	DC voltage controlled VSC Injects/extracts additional/less power from the HVDC grid to maintain its DC voltage reference, which is a function of the onshore AC frequency in PS3

**Table 2.** The different study cases investigated for primary frequency control purpose. Each study case is described with associated converter controllers and communication method to the OWPP

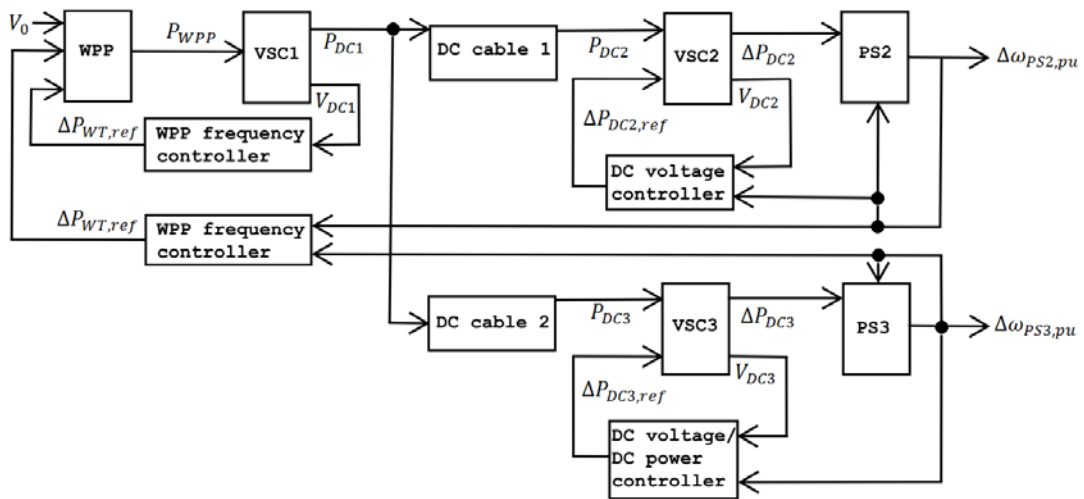

**Figure 9.** Overview of the block diagram of the VSC-HVDC intertie system and main controllers

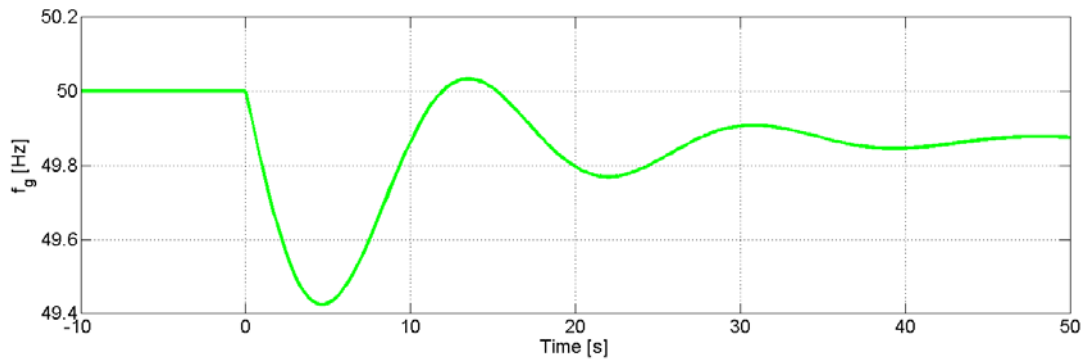

**Figure 10.** Base case: Onshore AC frequency response of either system, when neither the OWPP nor the other undisturbed onshore AC power system is participating in the primary frequency control