

## LONG-TERM PERFORMANCE OF LVL-CONCRETE COMPOSITE BEAMS UNDER SERVICE LOAD

David Yeoh<sup>1</sup>, Massimo Fragiaco<sup>2</sup>, Bruce Deam<sup>3</sup>

**ABSTRACT:** The long-term behaviour of timber-concrete composite is characterized by the response of its three components (timber, concrete and connection) to load, moisture content, temperature and relative humidity of the environment. This paper reports results of a 4-years long-term test on three 8m span laminated veneer lumber (LVL)-concrete composite floor beams under service load performed in an indoor, uncontrolled, and unheated environment at the University of Canterbury. The environmental conditions were characterized by either low temperature with high relative humidity or high temperature with low relative humidity, conditions considered to be reasonably severe and presumably close to service class 3 according to Eurocode 5. The mid-span deflections were extrapolated to the end of service life (50 years) and compared to span/200 deflection limit, which was exceeded by all beams.

**KEYWORDS:** Timber-concrete composite (TCC), Laminated veneer lumber (LVL), Long-term performance, time-dependent behaviour

### 1 INTRODUCTION

Timber-Concrete Composite (TCC) floors represent a construction technique where a concrete slab is connected on top of timber joists using different types of connector [1]. The three components of TCC floors, timber, concrete and connection, are characterized by different time-dependent behaviour, which depends upon several factors such as stress level, moisture content, temperature and relative humidity of the environment. The main long-term design parameter that must be considered for TCC floors is deflection. The long-term performance of TCC floors is complex and depends upon a number of phenomena such as creep, drying shrinkage and thermal strains of concrete; creep, timber and moisture strains of timber; and creep of connection [2]. Factors such as timber size, timber surface properties, loading type, length of environmental cycle, and moisture diffusion also indirectly affect the long-term behaviour of TCC floors [3]. Experimental long-term tests of TCC are costly and require detailed preparation. Nevertheless, such tests are crucial to

validate approximate design procedures and calibrate existing analytical and numerical models.

To date, few long-term tests have been performed and a summary of these recent tests are found in [4]. Numerical [5-7] and analytical [8-9] models have been proposed to predict the long-term behaviour of TCC structures. A TCC beam of 8 m span with glued-in connection was tested over a period of two years in a sheltered outdoor condition [10]. The relative humidity exceeded 85% over a number of days. The short-term deflection estimated using Eurocode 5 [11] was significantly exceeded during the two year period and consequently the prescribed limitation on the long term deflection was also exceeded. In another test, a TCC floor system of 6 m span with glued-in connection was subjected to a uniformly distributed load over a period of 5 years in unsheltered, outdoor conditions [2]. The moisture content did not exceed the 20% limit over the tested period, however the relative humidity exceeded 85% over a number of weeks. The environmental conditions would therefore classify as service class 3. While the test results were best approximated by coefficients for service class 3, they were still above the Eurocode 5 [11] predictions.

At the University of Canterbury, New Zealand, an innovative semi-prefabricated laminated veneer lumber (LVL)-concrete composite floor system has been developed and tested [12]. This paper presents 4-years long-term test results on this floor system under service load.

<sup>1</sup> David Yeoh, Faculty of Civil and Environmental Engineering, Universiti Tun Hussein Onn Malaysia, 86400 Batu Pahat, Johor, Malaysia. E-mail: [david@uthm.edu.my](mailto:david@uthm.edu.my)

<sup>2</sup> Massimo Fragiaco, Department of Architecture, Design and Urban Planning, University of Sassari, Palazzo del Pou Salit, Piazza Duomo 6, 07041 Alghero, Italy. E-mail: [fragiaco@uniss.it](mailto:fragiaco@uniss.it)

<sup>3</sup> Bruce Deam, Department of Civil and Natural Resources Engineering, University of Canterbury, Christchurch, New Zealand. E-mail: [bruce.deam@canterbury.ac.nz](mailto:bruce.deam@canterbury.ac.nz)

## 2 LONG-TERM TEST SETUP

Three 8 m span, T-section floor beams (designated as H, I and J), were built and housed in a garage with uncontrolled and unheated environmental conditions (Figure 1). These were simply supported on seats built from LVL so that the seats were loaded parallel to the grain. Two beams, H and I, had a single LVL joist, a 600 mm wide slab with 6 connectors type R300 (126 mm width  $\times$  50 mm depth  $\times$  300 mm length) reinforced with  $\phi$ 16 mm coach screw along the span (Figure 2(a)). Beam H was cast with normal concrete and beam I with low shrinkage concrete. Beam J had a double LVL joist, a 1200 mm wide low shrinkage concrete slab with 8 connectors type P (a pair of 1 mm thick  $\times$  136 mm deep  $\times$  333 mm long tooth metal plate with perforated holes at the top) along the span (Figure 2(b)). Beam H was cast on the 25<sup>th</sup> February 2008 (towards the end of summer) and beams I and J the next day.



**Figure 1.** Floor beams long-term tests in a garage

All the beams were propped at mid-span for the first seven days. The concrete was cured for 5 days after setting (approximately 6 hours after pouring) using damp Hessian sacks, and at day 36 (1<sup>st</sup> April 2008, autumn) a superimposed load of 2.2 kN/m<sup>2</sup> was applied using sealed buckets of water as the quasi-permanent load condition  $G + 0.4Q$  for serviceability limit state design. Important quantities such as temperature, relative humidity, mid-span and support vertical displacements were measured every minute during casting and loading for the initial 24 hours and every hour for the remainder of the long-term test. Mid-span displacements were corrected to remove support settlements (e.g. due to compression of the seats) by subtracting the average support displacements. A moisture content block from the same batch of LVL was placed under the slab of one of the floor beams, adjacent to the LVL joist. The weight of this block was recorded periodically using a digital scale for 1.5 year from the start of test, a time span sufficient to represent the annual moisture content fluctuation in the LVL. The oven-dried moisture content of the LVL block was obtained at the end of the 1.5 year. The periodical moisture contents of the LVL were calculated from the oven-dried weight of the block.

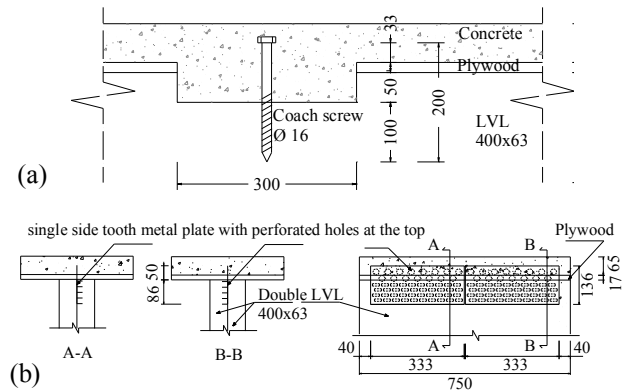

**Figure 2.** Two types of connection in long-term tests: (a) Type R300, rectangular notch cut in LVL reinforced with  $\phi$ 16 mm coach screw; (b) Type P, toothed metal plates pressed into the lateral face of the LVL (dimensions in mm)

### 2.1 MATERIAL PROPERTIES

The LVL used for the construction of the connection and floor beam specimens had  $400d \times 63w$  mm cross-section where  $d$  and  $w$  are the depth and width, respectively. The mean Young's modulus of the LVL was 11.34 GPa and the characteristic bending strength was 48 MPa, based on independent quality control testing [13]. Both normal weight and low shrinkage concrete were ordered to provide the following properties: 35 MPa characteristic compressive strength, 13 mm diameter maximum aggregate, and 120 mm slump. The low shrinkage concrete had Eclipse admixture which is readily available in the New Zealand market. Cylinder compressive strength tests to NZS3112 Part 2 [14] gave 28 day compressive strengths of 45 MPa for both concrete types. The mean drying shrinkages were 400 and 910 microstrain at 28 days for the low shrinkage and normal weight concrete, respectively.

## 3 TEST RESULTS AND OBSERVATIONS

The mid-span deflection trends for floor beams H, I and J from 25<sup>th</sup> February 2008 to 13<sup>th</sup> March 2012 in an uncontrolled indoor environment are presented in Figure 3. The mid-span deflections for the beams at different key events such as the removal of the prop, the load application, and the start of winter and summer as shown in Figure 3, are summarized in Table 1. The test results reported are up to 4 years and the test is still on-going.

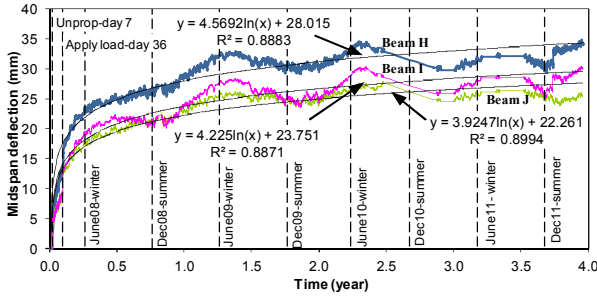

**Figure 3.** Mid-span deflection of beams H, I and J tested in the long-term (from 25<sup>th</sup> February 2008 to 13<sup>th</sup> March 2012) under sustained load and analytical fitted curves using logarithmic function equations

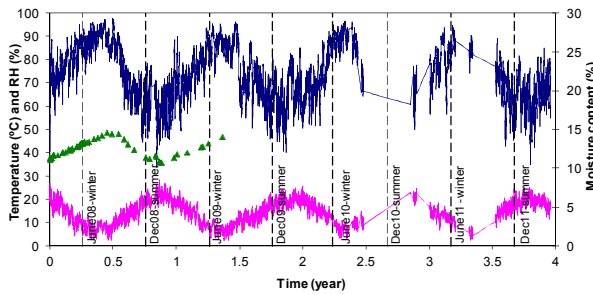

**Figure 4.** Relative humidity, temperature, and average LVL moisture content changes throughout the long-term tests (from 25<sup>th</sup> February 2008 to 13<sup>th</sup> March 2012)

The mid-span deflection of all beams raised significantly after the props were removed and the service loads applied until 0.3 year (approximately the first 3 months). Apart from the prop removal and load application, the extreme environmental conditions during that time frame also contributed to the large increase in deflection. This is further discussed in the following section. Subsequently, there were only gradual increases, with yearly fluctuations most likely due to the environmental changes in the garage, although there were some sorts of plateaus approaching summer of each year. The 5.35 to 6.74 mm initial beam deflections ( $\Delta_{G,inst}$ ) were caused by the self-weight of the floors after the removal of the props (Table 1). These were near the 5.8 to 5.9 mm deflections predicted using the Eurocode 5 [11] formulas for composite beams with flexible connections and the slip modulus recommended in [15] for the serviceability limit state. Prior to the application of the superimposed load at 36 days, this deflection had increased by approximately 7.3 mm for beam H, 4.5 mm for beam I and 3.9 mm for beam J (Table 1). Application of the superimposed load initially increased the deflections ( $\Delta_{Q,inst}$ ) by approximately 1.6 to 2.6 mm, about 30% to 50% of the initial self weight deflections ( $\Delta_{G,inst}$ ). The use of low shrinkage concrete (beam I) was shown to reduce the deflection by approximately 14% compared to normal weight concrete (beam H). The deflection for beams H, I and J observed to date (4 years) were 34.0 mm, 29.9 mm and 25.5 mm, respectively.

**Table 1.** Mid-span deflections of beams at different key times

Keytimes	Day	Year	Deflection at mid span (mm)			
			Beam H	Beam I	Beam J	
Concrete casting	0	0	0	0	0	
Removal of prop $\Delta_{G,inst}$	7		6.74	5.35	6.17	
Application of load $\Delta_{bef}$	36	0.10	14.0	9.8	10.1	
			$\Delta_{af}$	15.9	12.4	11.7
			$\Delta_{Q,inst} = \Delta_{af} - \Delta_{bef}$	1.90	2.57	1.60
			$\Delta_{G,inst} + \Delta_{Q,inst}$	8.64	7.92	7.77
			Ratio $\Delta_Q/\Delta_G$	0.28	0.48	0.26
June 2008 - winter	95	0.26	23.2	19.3	17.6	
Dec 2008 - summer	277	0.76	26.9	21.6	21.7	
June 2009 - winter	460	1.26	32.2	27.6	25.5	
Dec 2009 - summer	642	1.76	31.0	25.3	25.1	
June 2010 - winter	818	2.24	33.2	29.0	26.5	
Dec 2010 - summer	975	2.67	31.2	26.9	25.7	
June 2011 - winter	1157	3.17	31.7	28.0	26.1	
Dec 2011 - summer	1340	3.67	30.4	25.9	25.3	
Current - Mar 2012, $\Delta_{4y}$	1445	3.96	34.0	29.9	25.5	
End of service life (analytical), $\Delta_{50y}$			45.9	40.3	37.6	
Ratio $\Delta_{4y}/(\Delta_{G,inst} + \Delta_{Q,inst})$			3.94	3.77	3.28	
Ratio $\Delta_{50y}/(\Delta_{G,inst} + \Delta_{Q,inst})$			5.31	5.09	4.84	

Based on the experimental results, a logarithmic function equation is fitted in order to provide an analytical prediction of the end of service life 50 years deflection. These analytical fitted curves are presented in Figure 3 and tabulated in Table 2. Using these equations, the end of service life deflection for all the beams are given in Table 1. The final deflection predicted for the beams H, I and J are 45.9 mm, 40.3 mm and 37.6 mm, respectively. Such values exceed the commonly accepted limit of 40 mm (span/200). It is important to note that the environmental conditions which the beams were exposed to were rather severe. Also, it was difficult to fit the logarithmic curve to fluctuating experimental results which are likely to introduce additional errors. Nevertheless, the predictions made give some indication of the expected long-term deflections of TCC beams and their relationship with the environmental conditions, which are discussed in the following section. Furthermore, these analytical estimations are in most instances larger than the corresponding experimental measured deflection, therefore more conservative as illustrated in an experimental-analytical comparison at year 1, 2, and 4 (Table 3).

**Table 2.** Logarithmic function equations for tested beams fitted to the experimental results

	Equation	R-value
Beam H	$\Delta = 4.57\ln(t) + 28.0$	0.89
Beam I	$\Delta = 4.23\ln(t) + 23.8$	0.89
Beam J	$\Delta = 3.93\ln(t) + 22.3$	0.9

Note: t is time in year

**Table 3.** Experimental-analytical deflection of beams in mm for year 1, 2, 4 and 50 (end of service life)

Year	1		2		4		50	
	Exp.	Analy.	Exp.	Analy.	Exp.	Analy.	Exp.	Analy.
Beam H	28.8	28.0	29.6	31.2	34.0	34.3	-	45.9
Beam I	23.9	23.8	24.7	26.7	29.9	29.6	-	40.3
Beam J	23.0	22.3	24.2	25.0	25.5	27.7	-	37.6

## 4 ENVIRONMENTAL CONDITIONS

The physical environment for the beams is represented by the relative humidity (RH) and temperature data plotted in Figure 4. This can be characterized as either low temperature with high RH or high temperature with low RH. The minimum, average and maximum temperatures of the colder months were 2.1 °C, 7.8 °C and 14.1 °C; and warmer months were 13.4 °C, 20.3 °C and 28.4 °C, respectively. This gives an average difference of 12.7 °C between the two seasons. The daily fluctuations of the two quantities are important because the beams were in indoor, unheated conditions, particularly the temperature in the colder months and the RH in the warmer months. For example, during winter, the maximum differences in daily temperature and RH were observed to be 5.8 °C and 13.3%, and in summertime, 7.0 °C and 29.7%, respectively.

An attempt to draw a relationship between the RH, temperature and deflection of the beams with the moisture content (MC) of the LVL is also shown in Figure 4. The average MC of the LVL monitored for the first 1.5 year ranged between 10.7 to 14.6%. It is clear that low temperatures and high RH increased the MC of the LVL and consequently caused the deflection increases during the winter months between June and August every year. In these periods, the temperature dropped to the lowest value (2.6 °C), whilst RH, MC and the beam deflections raised to the highest values (92.5%, 14.6% and 27.4 mm during year 1). The temperature then raised to a 26 °C peak with the lowest RH (48.7%) in summer months between December to February when the MC descended to 10.8%. During this time, the deflections in all the beams remained in a sort of plateau before the pattern repeated in the following year. Analysis of the experimental environmental data using the CSIRO equilibrium moisture content (EMC) chart [16] indicated that the EMC in the garage varied considerably and was particularly high in the cooler months – varying between approximately 7% in the warmer months to more than 25% in the cooler months. This compares with the 8% to 12% range normally measured in heated, indoor conditions.

Although the MC of the LVL was below 20%, the RH was more than 75% for approximately 18 weeks during winter each year. These limits make the environmental condition for the beams close to service class 3 in accordance with Eurocode 5 [11], for which a creep coefficient  $k_{def} = 2$  is recommended. According to the NZ3603 [17], a long-term duration factor  $k_2 = 3$ , corresponding to a creep coefficient of 2, should be assumed. The significant EMC variation may have

contributed to the high creep and deflection. It is well known that it is not just the level of moisture content that affects creep deflections. The rate of change and number of cycles of moisture content and therefore EMC can have a more significant effect on creep behaviour, with rapid changes in EMC producing more severe creep under bending loads (the so-called mechano-sorptive creep [3]).

It is also evident that the creep mechanism is worse for longer spans where the stiffness of the floor is much more dependent on composite action between the concrete and the timber beams. The significant effect of variation in EMC on the long-term behaviour of TCC floors is confirmed by several literature references. Concrete creep and the various interactions of shrinkage and creep, shrinkage or swelling in the LVL, and creep of the connection system, contribute to significant additional deformation in TCC floor structures. Five year long-term tests on TCC beams using glued-in rebars as connectors had most of the deflection developed during the first two years, after which creep deflections tended to either plateau or to increase much more slowly [2]. However, another test on TCC beams with inclined proprietary (SFS) connectors showed a distinct increase through a 5-year experiment, with minimal reduction in the rate of deflection increase after the end of the second year [18].

When interpreting the data plotted in Figure 3 and Figure 4, it is important to note that the daily deflection fluctuations at any point were attributed to the changes in relative humidity and temperature. The increase in deflection over time appeared to be accentuated by the cold weather or, more specifically, the low temperature, noting that the lowest temperatures during the winter months caused the greatest deflection. This is explained by the different thermal expansion rates and conductivities of timber and concrete. During wintertime the timber moisture content increased, leading to an elongation of the timber beam and increasing deflections since the timber beam is below the concrete slab which it is connected to. Conversely, in the warmer months after winter, the gradual reduction in timber moisture content maintained the deflections for all the beams until the next cold period and its accompanying deflection increase. This mechanism is consistent with the behaviour observed in other experimental tests and numerical modelling [2, 7 and 18].

## 5 CONCLUDING REMARKS

Long-term tests on three 8 m span TCC beams were conducted in an uncontrolled, unheated indoor environment. Test results from sustained loading durations of up to 4 years are presented in this paper. The specimens were exposed to environmental conditions characterized by either low temperature with high relative humidity or high temperature with low relative humidity, conditions considered to be reasonably severe almost close to service class 3 according to Eurocode 5. Some important findings observed are:

- The beam deflections fluctuated in response to the environmental changes.
- Large deflection increments were induced by the low temperatures and equivalent high equilibrium moisture content during the cooler months, while in the warmer months with higher temperatures and low equilibrium moisture content, reduced deflection increments were monitored.
- Beam I, built from low shrinkage concrete, deflected approximately 14% less than beam H with normal shrinkage concrete.
- The superimposed load induced an instantaneous deflection of 30% to 50% of the initial self weight deflection ( $\Delta_{G,inst}$ ).
- A significant portion of the deflection occurred in the first quarter of the first year. A consistent annual trend of deflection increase due to environmental changes is observed each year towards a sort of global plateau.
- The ratio of the final long-term deflection to the short-term deflection due to dead load and imposed load,  $\Delta_{50}/(\Delta_{G,inst} + \Delta_{Q,inst})$ , is estimated approximately in the order of 5.0 for TCC built from low shrinkage concrete and 5.3 or above for TCC built from normal weight concrete, exposed to similar environmental condition as in this test.
- The mid-span deflections were extrapolated to the end of service life (50 years), with the final deflection for the beams predicted to have exceeded the commonly accepted limit of 40 mm (span/200). It is important to note that the environmental conditions which the beams were subjected to were rather severe. Also, there was some difficulty to fit a logarithmic curve to fluctuating experimental results which are likely to introduce additional error.
- The results, for comparatively extreme environmental fluctuations, are indicative of the upper limits of long-term deflections that can be expected for TCC structures. More research needs to be undertaken for TCC floors in the more uniform indoor, air conditioned or heated environments.

## REFERENCES

- [1] Ceccotti, A.: Composite concrete-timber structures. *Progress in Structural Engineering and Materials*, 4(3): 264-275, 2002.
- [2] Ceccotti, A., Fragiaco, M., Giordano, S.: Long-term and collapse tests on a timber-concrete composite beam with glued-in connection. *Journal Materials and Structures RILEM*, 40(1):15-25, 2006.
- [3] Toratti, T.: Service limit states: Effects of duration of load and moisture on deformations. In *Cost E24 Reliability of Timber Structures*, 11 pp., 2004. Florence.
- [4] Yeoh, D., Fragiaco, M., De Franceschi, M., Koh, H.B.: The state-of-the-art on timber-concrete composite structures – a literature review. *Journal Structural Engineering ASCE*, 137(10): 1085 – 1095, 2011.
- [5] Fragiaco, M.: Long-term behaviour of timber-concrete composite beams. I: finite element modeling and validation. *Journal Structural Engineering ASCE*, 132(1): 13 – 22, 2006.
- [6] Schänzlin, J.: Time dependent behavior of composite structures of board stacks and concrete. PhD Thesis, University of Stuttgart (in German). 2003.
- [7] Fragiaco, M.: Long-term behaviour of timber-concrete composite beams. II: numerical analysis and simplified evaluation. *Journal Structural Engineering ASCE*, 132(1): 23 – 33, 2006.
- [8] Fragiaco, M., Ceccotti, A.: A simplified approach for long-term evaluation of timber-concrete composite beams. In: *Proceedings of 8th World Conference on Timber Engineering*, Vol. 2, pages 537 – 542, 2004. Lahti, Finland.
- [9] Schänzlin, J., Fragiaco, M.: Extension of EC5 Annex B formulas for the design of timber-concrete composite structures. In: *Meeting forty of the Working Commission W18-Timber Structures, CIB, International Council for Research and Innovation*, 40-10-1, 10 pp., 2007. Bled (Slovenia).
- [10] Bou Said, E., Jullen, J.F., Ceccotti, A.: Long term modelling of timber-concrete composite structures in variable climates. In: *Proceedings of 8th World Conference on Timber Engineering*, Vol 2, pages 143 – 148, 2004. Lahti, Finland.
- [11] CEN Comité Européen de Normalisation: Eurocode 5 – Design of timber structures – Part 1-1: General rules and rules for buildings. 2004. Brussels, Belgium.
- [12] Yeoh, D., Fragiaco, M., Buchanan, A., Gerber, C.: Preliminary research towards a semi-prefabricated LVL-concrete composite floor system for the Australasian market. *Australasian Journal Structural Engineering*, 9(3): 225-240, 2009.
- [13] Gaunt, D., Penellum, B.: Phase 1 Truform In-grade Testing for Carter Holt Harvey, New Zealand Forest Research Institute Limited, New Zealand. Report TE03-037, 6 pp., 2004.
- [14] SNZ Standard New Zealand: NZ3112 – Specification for methods of test for concrete – Part 2: Tests relating to the determination of strength of concrete. 1986. Wellington, New Zealand.
- [15] Ceccotti, A.: Timber-Concrete Composite Structures, *Timber Engineering, Step 2*, 1st Edn. (Centrum Hout, The Netherlands) E13/1-E13/12. 1995.
- [16] Blakemore, P.: The use of hand-held electrical moisture meters with commercially important Australian hardwoods, Part 2 for Forest Wood Products Research and Development Corporation. CSIRO Forestry and Forest Product, Project No. PN 01.1306, p 191, 2003. Australia.
- [17] SNZ Standards New Zealand: NZS 3603 – Design timber structures. 1993. Wellington, New Zealand.
- [18] Kenel, A., Meierhofer, U.: Long-term performance of timber-concrete composite structural elements. Report. No. 115/39, EMPA, Dübendorf, Switzerland (in German). 1998.