

PREVENTING CRACKING AT DIAPHRAGM/PLATE GIRDER CONNECTIONS IN STEEL BRIDGES

Sponsored by the
Iowa Department of Transportation
and the Iowa Highway Research Board
Iowa DOT Project HR-393

JUNE 1998



*Center for Transportation
Research and Education*

IOWA STATE UNIVERSITY



**Iowa Department
of Transportation**

The opinions, findings, and conclusions expressed in this publication are those of the authors and not necessarily those of the Iowa Department of Transportation.

CTRE's mission is to develop and implement innovative methods, materials, and technologies for improving transportation efficiency, safety, and reliability, while enhancing the educational experience of students in transportation-related fields.

PREVENTING CRACKING AT DIAPHRAGM/PLATE GIRDER CONNECTIONS IN STEEL BRIDGES

Principal Investigator

T.J. Wipf, Professor of Civil Engineering
Iowa State University

Co-Principal Investigator

L.F. Greimann, Professor of Civil Engineering
Iowa State University

Graduate Research Assistants

A.H. Khalil
D. Wood

**Sponsored by the
Iowa Department of Transportation
and the Iowa Highway Research Board
Iowa DOT Project HR-393**

Center for Transportation Research and Education Iowa State University

Iowa State University Research Park
2625 North Loop Drive, Suite 2100
Ames, IA 50010-8615
Telephone: 515-294-8103
Fax: 515-294-0467
<http://www.ctre.iastate.edu>

June 1998

ABSTRACT

Some of the Iowa Department of Transportation (Iowa DOT) continuous, steel, welded plate girder bridges have developed web cracking in the negative moment regions at the diaphragm connection plates. The cracks are due to out-of-plane bending of the web near the top flange of the girder. The out-of-plane bending occurs in the “web-gap,” which is the portion of the girder web between (1) the top of the fillet welds attaching the diaphragm connection plate to the web and (2) the fillet welds attaching the flange to the web. A literature search indicated that four retrofit techniques have been suggested by other researchers to prevent or control this type of cracking: (1) drilling holes at crack tip locations, (2) increasing the web gap length, (3) providing rigid attachment between the connection plate and the tension flange, and (4) removing the diaphragms.

To eliminate the problem in new bridges, current AASHTO Specifications require a positive attachment between the connection plate and the top (tension) flange. Applying this requirement to existing bridges is expensive and difficult. The Iowa DOT has relied primarily on the hole-drilling technique to prevent crack extension once cracking has occurred; however, the literature indicates that hole-drilling alone may not be entirely effective in preventing crack extension.

The objective of this research was to investigate experimentally a method proposed by the Iowa DOT to prevent cracking at the diaphragm/plate girder connection in steel bridges with X-type or K-type diaphragms. The method consists of loosening the bolts at some connections between the diaphragm diagonals and the connection plates.

The experimental investigation of the method included selecting and testing five bridges: three with X-type diaphragms and two with K-type diaphragms. During 1996 and 1997, these bridges were instrumented using strain gages and displacement transducers to obtain the response at various locations (web gaps, diaphragm elements, and girder flanges and webs) before and after implementing the method. Bridges were subjected to loaded test trucks traveling in different lanes with speeds varying from crawl speed to 65 mph (104 km/h) to determine the effectiveness of the proposed method.

The results of the study show that the effect of out-of-plane loading was confined to widths of approximately 4 inches (100 mm) on either side of the connection plates. Further, they demonstrate that the stresses in gaps with drilled holes were higher than those in gaps without cracks, implying that the drilling hole technique is not sufficient to prevent crack extension. The behavior of the web gaps in X-type diaphragm bridges was greatly enhanced by the proposed method as the stress range and out-of-plane distortion were reduced by at least 42% at the exterior girders. For bridges with K-type diaphragms, a similar trend was obtained. However, the stress range increased in one of the web gaps after implementing the proposed method. Other design aspects (wind, stability of compression flange, and lateral distribution of loads) must be considered when deciding whether to adopt the proposed method.

Considering the results of this investigation, the proposed method can be implemented for X-type diaphragm bridges. Further research is recommended for K-type diaphragm bridges.

TABLE OF CONTENTS

LIST OF FIGURES	VI
LIST OF TABLES	IX
INTRODUCTION.....	1
Background	1
Objective and Scope.....	3
Literature Search.....	3
DESCRIPTION OF BRIDGES.....	5
Boone River Bridge (Bridge X1).....	5
Des Moines River Bridge (Bridge X2).....	5
I-80 Bridge over Abandoned Rail Road (Bridge x3).....	7
I-80 Bridge over the Mosquito Creek-Westbound (Bridge K1).....	10
I-80 Bridge over IA-192-Westbound (Bridge K2).....	10
RESEARCH METHODS.....	14
General.....	14
Loading and Test Procedure.....	14
Loading	14
Test Procedure	16
Instrumentation	20
Measurements and Locations	26
Data Analysis.....	29
FIELD TESTS RESULTS AND DISCUSSION.....	32
Local Effect of the Method.....	32

Web Gap Strains	32
X-Type Diaphragm Bridges	32
K-Type Diaphragm Bridges	42
Web Gap Out-of-Plane Distortion.....	47
X-Type Diaphragm Bridges	47
K-Type Diaphragm Bridges	51
Web Gap Relative Vertical Displacement.....	52
Diaphragm Diagonal Forces (X-Type and X-Type Diaphragm Bridges)	53
Global Effect of the Method.....	54
Lateral Distribution of Loads	54
ASSESSMENT OF THE PROPOSED METHOD.....	61
Experimental Evaluation.....	61
Other Design Aspects.....	61
SUMMARY, CONCLUSIONS AND RECOMMENDATIONS	64
Summary.....	64
Conclusions.....	65
Recommended Further Research	66
ACKNOWLEDGMENT	67
REFERENCES	68

LIST OF FIGURES

Figure 1.	Description of out-of-plane girder web distortion in the gap region	2
Figure 2.	Boone River Bridge on IA-17 (Bridge X1).....	6
Figure 3.	Des Moines River Bridge on IA-210 (Bridge X2).....	8
Figure 4.	The I-80 Bridge no. 7804.8L080 (Bridge X3).....	9
Figure 5.	The I-80 Bridge over the Mosquito Creek (Bridge K1)	12
Figure 6.	The I-80 Bridge over IA-192 (Bridge K2)	13
Figure 7.	Trucks used for testing Bridge X1	15
Figure 8.	Schematic plan and cross section of Boone River Bridge (Bridge X1) showing instrumentation and loosened bolts locations	18
Figure 9.	Schematic plan and cross sections of Des Moines River Bridge (Bridge X2) showing instrumentation and loosened bolts locations	19
Figure 10.	Schematic plan and cross sections of Bridge no. 7804.8L080 (Bridge X3) showing instrumentation and loosened bolts locations	22
Figure 11.	Schematic plan and cross sections of Mosquito Creek Bridge (Bridge K1) showing instrumentation and loosened bolts locations	23
Figure 12.	Schematic plan and cross sections of IA-192 Bridge showing instrumentation and loosened bolts locations	25
Figure 13.	Typical EX and EK instrumentation details.....	30

Figure 14.	Crack and drilled holes at Location HX3.....	31
Figure 15.	Strain recorded in the web gap region at Location EX1 during Test 5.....	33
Figure 16.	Vertical profile of the maximum strains in the web gap at Location EX1 during Tests 1-4	34
Figure 17.	Vertical profile of the maximum strains in the web gap at Location EX2 during Tests 1-4	35
Figure 18.	Vertical profile of the maximum strains in the web gap at Location BX1 during Tests 1-4	37
Figure 19.	Vertical profile of the maximum strains in the web gap at Location RX2 during Tests 10-13.....	38
Figure 20.	Comparison among maximum strains at Locations EX3 during Test 2 (tight), Test 5 (partial loose), Test 7 (loose) and Test 8 (all bolts loose).....	39
Figure 21.	Comparison among strains before and after loosening the bolts at Location IX3.....	40
Figure 22.	Horizontal profile of maximum vertical strains in the web gap of Locations EX3 and RX3 during Tests 2 (tight), 5 (partial loose), and 7 (loose)	41
Figure 23.	Vertical profile of maximum strains in the web gap at Location EK1 during Tests 1-3 (tight condition tests).....	44
Figure 24.	Vertical profile of the maximum strains in the web gap at Location EK2 during Test 1 (tight), Test 4 (partial loose), and Test 7 (loose).....	45
Figure 25.	Vertical profile of the maximum strains in the web gap at Location IK2 during Test 2 (tight), Test 5 (partial loose), and Test 8 (loose).....	48

Figure 26.	Vertical profile of the maximum strains in the web gap at Location AK1 during Test 1 (tight), and Test 5 (loose).....	49
Figure 27.	Maximum out-of-plane displacements of Locations EX3, IX3, and HX3 during tight, partial loose, and loose tests.....	55
Figure 28.	Maximum out-of-plane displacements of Locations EK2 and IK2 during tight, partial loose, loose, and all bolts loose tests.....	56
Figure 29.	Web extension and flange out-of-plane rotation at Location IX1 during Tests 1-4 and 10-13	57
Figure 30.	Out-of-plane distortion, top gage strain, and diaphragm diagonal force at Location EX2 during Tests 1-4.....	59
Figure 31.	Maximum exterior girder bottom flange strains in Bridge X2 during tight and loose condition tests.....	60

LIST OF TABLES

Table 1.	Weight of loaded test trucks used in testing the five bridges.....	15
Table 2.	Test description for Bridges X1 and X2.....	17
Table 3.	Test description for Bridge X3	21
Table 4.	Test description for Bridge K1	21
Table 5.	Test description for Bridge K2.....	24
Table 6.	Maximum stress range in the tested web gaps due to a single test truck.....	43
Table 7.	Maximum out-of-plane distortion of the tested web gaps due to a single test truck ...	50
Table 8.	Maximum force in the diaphragm diagonals due to a single test truck	58

INTRODUCTION

Background

Cracks have developed in steel bridge components due to fatigue during the past several decades. Some of these have resulted in brittle fracture of the member. Out-of-plane distortions of the web at the diaphragm connection plates of multiple girder bridges are the cause of the largest category of cracking in bridges [1]. The distortion problem has developed in other types of bridges, including suspension bridges, two girder floor beam bridges, tied arch bridges, and box girder bridges.

Figure 1 shows a schematic of the out-of-plane distortion at the end of diaphragm connection plates in plate girder bridges. Under typical vehicle loading, differential vertical deflection of adjacent girders causes forces to develop in the diaphragm elements which cause the out-of-plane loading on the girder web (Detail A). Without the connection plate attached to the top flange and with the top flange rigidly connected to the bridge deck by shear connectors, these forces pass through the girder web causing out-of-plane distortion and, hence, bending of the web gap immediately adjacent to the top flange (Detail B). In the negative moment regions, high cyclic stresses due to this distortion cause cracking in the web gap region typically parallel to the longitudinal tensile stresses [2]. Various types of diaphragms and girder spacing have been subjected to this type of cracking. Diaphragms ranged from X- and K-type bracing to rolled beam sections [3].

In Iowa, some of the Iowa DOT continuous, steel, welded plate girder bridges have developed web cracking in the negative moment regions at diaphragm connection plates. Current AASHTO Specifications [4] require a positive attachment between the connection plates for the diaphragms and both girder flanges. However, for many existing bridges, the connection plates are welded only to the web and the compression flange because the bridge specifications at the time these bridges were constructed discouraged welding of connection plates to the tension flanges. It should be noted that hereafter, “connection plates” and “stiffeners” are used interchangeably.

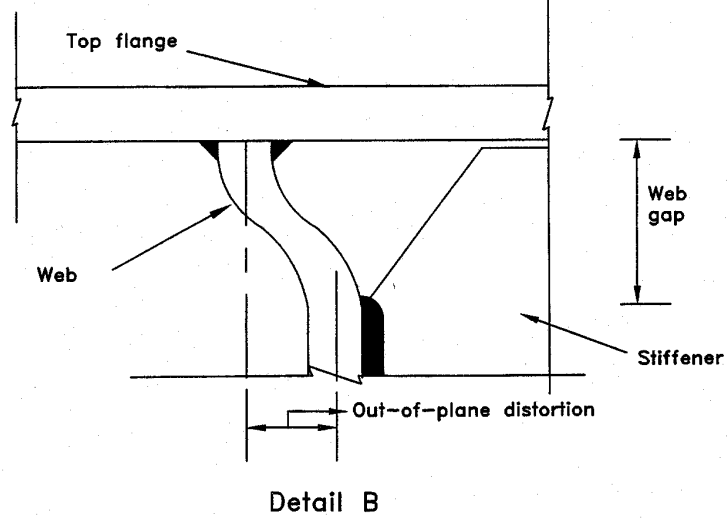
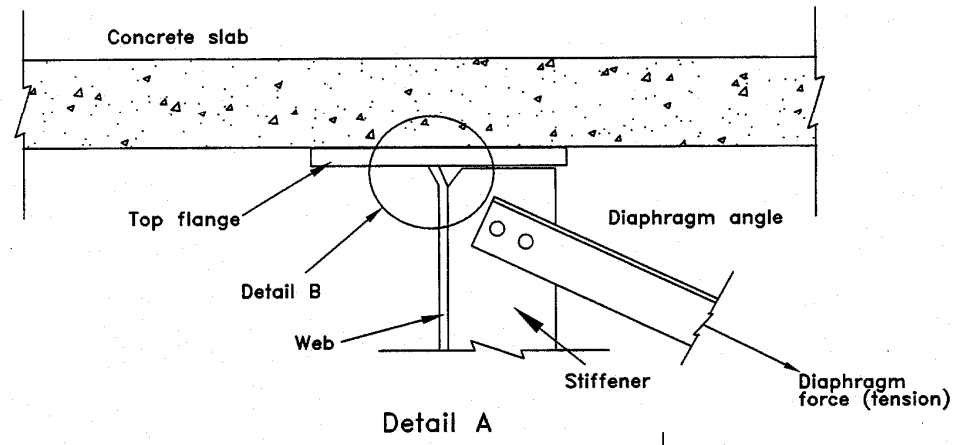
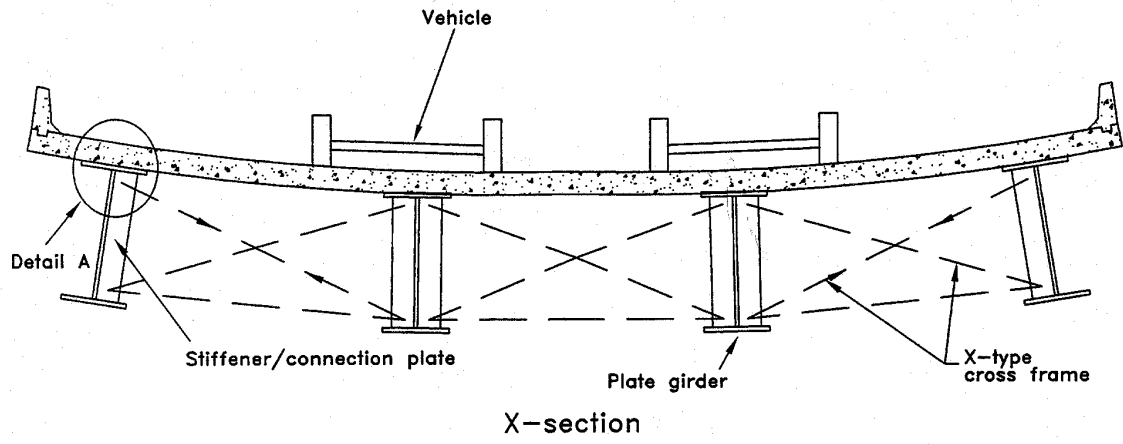

Figure 1. Description of out-of-plane girder web distortion in the gap region

Objective and Scope

The primary objective of this study was to investigate a retrofit method proposed by the Iowa DOT to prevent web cracking. This method consists of loosening the bolts at selected connections between the diaphragm diagonals and the connection plates, which are not welded to the tension flange. The scope of the investigation included studying the cracking problems occurring at the diaphragm/plate girder connections in negative moment regions of continuous plate girder bridges, identifying existing methods of crack prevention/control, and comparing the out-of-plane distortion of the web for X-type and K-type diaphragms.

During the early stages of the study, a comprehensive literature review was conducted. In the experimental phase of this study, the proposed method was evaluated for potential field use. After conducting a preliminary field and theoretical investigation of the method, field tests on five bridges, with two transverse bracing systems, were conducted. Three bridges having X-type diaphragms were tested: one non-skew bridge and two skew bridges. The other two bridges, one non-skew and one skew, had K-type diaphragms. During tests, strains and displacements at various locations were measured to assist in evaluating the effect of the proposed method on the local and global behavior of these bridges. Loaded test trucks, provided by the Iowa DOT, as well as ambient traffic, were utilized.

Literature Search

Fisher et al. [5, 6, 7] investigated causes of, and possible retrofit techniques for, distortion-induced cracking of steel girder bridges at web gaps. The field measurements indicated that most distortion-induced fatigue cracking develops in the web gap regions. Cracking would typically be evident within ten years. However, some extreme cases reported cracking due to wind induced vibration before the bridge opened [1]. The authors predict that the crack propagation rate might decrease as the crack grows. However, there were no experimental data to verify that prediction. The authors conducted laboratory tests on models having K-type and X-type diaphragms. Results show that using K-type diaphragms would yield longer fatigue life than using X-type diaphragms.

Different retrofit procedures for the connection plates, mostly destructive in nature, were examined through laboratory testing. Using any of the following methods was suggested.

1. Drilling holes at the crack tip:

As suggested by the authors, this method should be used with any of the methods described hereafter to minimize crack extension. This method may be satisfactory alone if the crack has propagated into a lower stress region.

2. Increasing the web gap length:

This method increases the flexibility of the connection and, hence, reduces the bending stresses in the web plate. However, it may cause greater distortion at the connection. This retrofit can be used at most floor beam/girder connections but not at diaphragm/girder connections.

3. Providing positive attachment:

Field tests showed that this method is the most effective. It can be accompanied by welding or bolting the connection plate to the top flange. Welding may be more effective; however, traffic should be stopped during welding and high-quality field welds may be difficult. Consequently, this method is seldom used for existing bridges.

Keating [8] suggested removing the diaphragms from the steel plate girder bridges to eliminate the source of cracking. Stallings et al. [9, 10] examined the retrofit methods that are used in Alabama for arresting cracks in steel plate girder bridges near diaphragm beam connections. They indicated that hole drilling is not reliable for preventing crack extension. Two bolted connections were designed to replace the connection between diaphragm beams and bridge girders. Although the stress range was reduced after implementing these connections, some connections experienced cracking after two years of service. The results of the study led to a recommended strategy of removing unnecessary diaphragms.

DESCRIPTION OF BRIDGES

The bridges selected for investigation in this study are similar to and representative of Iowa DOT steel plate girder bridges that have been subjected to web cracking due to out-of-plane distortion. One of the tested bridges, the I-80 Bridge with X-type diaphragms, has extensive fatigue cracking due to the out-of-plane distortion in the web gap regions. Each bridge has continuous spans with diaphragms connecting individual girders at the end of each span and at intermediate points and a reinforced concrete deck slab with composite construction. A brief description of each of the five bridges follows.

Boone River Bridge (Bridge X1)

The Boone River Bridge (Br. No. 4048.2S017) is located approximately 1.25 miles (2.0 km) south of U.S. 20 on Iowa Highway 17 (IA-17) in Hamilton County. It carries the north and southbound traffic over the Boone River (Figure 2). The roadway is 44-ft wide including two 10-ft shoulders. The bridge was constructed in 1972. It is a three-span, symmetric steel welded plate girder bridge with five girders of spans 97.5, 125, and 97.5 ft (29.7, 38.1, and 29.7 m), respectively. The girders with lateral spacing of 10 ft (3.0 m) support the 8-in. (200-mm) thick deck slab. The superstructure is supported on two abutments at the ends and on two intermediate piers in the Boone River. The vertical stiffeners, with spacing of approximately 5 ft (1.5 m), are closely fitted to the tension flange with an average web gap height of 2 in. (50 mm). X-type diaphragms brace girder webs at approximately 20-ft intervals. This bridge is inspected every two years. The last fatigue-type inspection was in 1992. A fatigue-type inspection is conducted every six years and under-bridge-access equipment is used to conduct these detailed inspections. No fatigue cracking has been observed in this bridge. Tests were conducted on the Boone River Bridge on September 19, 1996. Later, this bridge is referred to as Bridge X1.

Des Moines River Bridge (Bridge X2)

The Des Moines River Bridge (Br. No. 0804.9S210) carries Iowa Highway 210 (IA-210) over the Des Moines River west of Madrid in Boone County (Figure 3). The roadway



(a) Overview and roadway



(b) Diaphragm system

Figure 2. Boone River Bridge on IA-17 (Bridge X1)

consists of two 12-ft wide lanes, east and westbound, and two 10-ft shoulders. The bridge was opened to traffic in 1973. It has five continuous spans; the exterior spans are 176 ft (53.6 m) each and the interior spans are 220 ft (67.1 m) each. The bridge is skewed 29° with four piers and two abutments. The five girders with lateral spacing of 10 ft (3.0 m) are braced with rolled beam diaphragms over the abutments and the piers. Elsewhere, they are braced using X-type diaphragms at a spacing of 22 ft (6.7 m). Intermediate vertical stiffeners are provided at a spacing of 5.5 ft (1.70 m). In the negative moment regions, these stiffeners are not welded to the top (tension) flange, but are closely fitted to it with an average web gap height of 2 in. (50 mm). No fatigue cracking has been reported in the Des Moines River Bridge. The last fatigue-type inspection was conducted in July 1994. The inspection cycle is six years. The bridge was tested on October 16 and 17, 1996. This bridge is referred to in the following chapters as Bridge X2.

I-80 Bridge over Abandoned Railroad (Bridge x3)

This bridge (Br. No. 7804.8L080) is located in Pottawattamie County, 3.7 miles (5.9 km) west of the junction of Interstate 80 (I-80) with U.S. 6 Highway. It carries the westbound traffic of I-80 over an abandoned railroad (Figure 4). The bridge was constructed in 1965. The superstructure consists of four continuous steel plate girders topped by a reinforced concrete deck slab. The girders have three spans of 91.5, 117, and 91.5 ft (27.9, 35.7, and 27.9 m), respectively, with a lateral spacing of 9 ft-8 in. (2.9 m) and a total bridge width of 32 ft (9.8 m). The bridge has X-type diaphragms spaced at approximately 22 ft (6.7 m) intervals. The bridge superstructure is skewed 30° , and its supporting two piers and two stub reinforced concrete abutments are supported on piles. Vertical stiffeners are provided at intervals that do not exceed 3 ft-7 in. (1.1 m). Stiffeners are closely fitted to the tension flange with an average web gap height of 1.75 in. (44 mm). Fatigue cracks have been detected in the web gap region at nine locations. As a retrofit, holes were drilled at the crack tips. However, the cracks extended beyond the drilled holes in some locations. Crack extensions were treated by drilling holes at the new crack tip locations. The last fatigue-type inspection of the bridge was in September 1995. The bridge was tested on July 29, 1997. This bridge is referred to as Bridge X3.



(a) Overview and diaphragm system



(b) Roadway

Figure 3. Des Moines River Bridge on IA-210 (Bridge X2)



(a) Overview



(b) Diaphragm system

Figure 4. The I-80 Bridge no. 7804.8L080 (Bridge X3)

I-80 Bridge over the Mosquito Creek-Westbound (Bridge K1)

The bridge (Br. No. 7805.3L080) carries the I-80 westbound traffic over the Mosquito Creek, a local road, and Burlington Northern Railroad (Figure 5). It is located in Pottawattamie County, 3.2 miles (5.1 km) west of the junction of I-80 with U.S. 6 Highway. The bridge was constructed in 1968. The superstructure consists of seven-span continuous welded steel plate girder construction, with an intermediate hinge located in the fourth span. The bridge is skewed 44° with its supporting substructure with girder spans varying from 71 ft (21.6 m) to 100 ft (30.5 m). K-type diaphragms connect adjacent girders together at a maximum of 25 ft (7.6 m) intervals. Each diaphragm panel has two horizontal members: one near the top flange and the other near the bottom one. The connection plates are welded to the girder webs only and are close-fitted to the top and bottom flanges. This is unusual for Iowa bridges because the connection plates are normally welded to compression flanges. The maximum web gap height, measured while instrumenting the bridge, was 0.88 in. (23 mm).

A crack had been previously detected at one location in the weld connecting the stiffener to the web plate at the top of the stiffener. The Iowa DOT calls this type of crack a “Crown Crack.” It is caused by the out-of-plane distortion. A hole had been drilled through the weld to remove the crack. The last fatigue-type inspection of the bridge was in 1995. The bridge was tested on July 28, 1997. This bridge is referred to as Bridge K1.

I-80 Bridge over IA-192-Westbound (Bridge K2)

This bridge (Br. No. 7803.1L080) carries the westbound traffic of I-80 over Iowa Highway 192 (IA-192), a frontage road, and railroad siding. It is located in Pottawattamie County, 5.4 miles (8.6 km) west of the junction of I-80 with U.S. 6 Highway (Figure 6). The bridge was built in 1968. The roadway consists of three lanes (two 12 ft, 3.7 m, driving lanes and one exit lane) and two 10 ft (3.0 m) shoulders. The bridge superstructure consists of six-span steel welded multi-girder composite construction. The span lengths range from 50 ft (15.2 m) to 110 ft-6 in. (33.7 m). Span 4, crossing the northbound IA-192 and an access road, is the longest span. K-type diaphragms brace the girders at intervals varying from 19 ft (5.8 m) to 26 ft (7.9 m). Each

diaphragm panel has a lower and an upper horizontal chord. The web gap details are similar to those in Bridge K1 (i.e., connection plates are not welded to either the tension or the compression flange). However, intermediate cross frames exist only in the positive moment regions, between the splices of the longitudinal girders. There is no recorded fatigue cracking history for this bridge. The last fatigue-type inspection was in July 1994. The bridge was tested on July 29, 1997. Hereafter, this bridge is referred to as Bridge K2.

It is interesting to note that Bridges X3, K1, and K2 are all on I-80 (westbound) within two miles (3.2 km) distance from each other with no exits or entrances in between them. That means that all three bridges are subjected to the same amount of traffic loading. Bridge X3 has severe cracks resulting from out-of-plane distortion, while Bridges K1 and K2 are free from cracking due to distortion problems. This conforms with the observations made by earlier studies [6] that K-type diaphragm bridges have greater fatigue life than X-type diaphragm bridges.



(a) Overview and roadway



(b) Diaphragm system

Figure 5. The I-80 Bridge over the Mosquito Creek (Bridge K1)



(a) Overview



(b) Roadway



(c) Diaphragm system

Figure 6. The I-80 Bridge over IA-192 (Bridge K2)

RESEARCH METHODS

General

To assess the proposed retrofit method, bridge responses were measured at certain locations under the application of vehicular load before and after loosening the bolts connecting the diaphragm elements to the girder webs. There are two sets of bolts connecting diaphragm diagonals to the girder webs: an upper set and a lower set. In the case of X-type diaphragms, each set consists of two bolts for each diagonal; in the case of K-type diaphragms, there are three bolts per diagonal. For X-type diaphragms, loosening either set would induce an equivalent effect. The lower set of bolts is easily accessed in the field and, hence, the method was evaluated primarily by loosening these bolts. For the K-type diaphragms, loosening upper connection bolts was expected to have a greater effect on the web gap region. Therefore, top connection bolts were loosened in the field. Further, the effect of loosening both upper and lower diaphragm bolts was also evaluated. This chapter presents the test procedure, loading configuration, instrumentation, and the data analysis.

Loading and Test Procedure

Loading

The Iowa DOT provided two loaded rear tandem axle trucks for each bridge (see Figure 7 for trucks used for testing Bridge X1). The majority of the tests (described later) utilized only one truck traveling on the bridge in different lanes and shoulders at speeds varying from 5 mph (8 km/h, crawl speed) to more than 60 mph (96 km/h). For two bridges, however, the two trucks were run side by side in a few tests at the crawl speed. Different trucks were used during tests on different bridges; however, the dimensions and weights were consistently similar. Before testing, each truck was measured and weighed. The gross truck weight ranged from 49 kips (220 kN) to 53 kips (238 kN). Table 1 lists the front axle, rear axle, and gross weights of the test trucks. Although not reported here, additional data were collected during ambient heavy truck traffic.



Figure 7. Trucks used for testing Bridge X1

Table 1. Weight of loaded test trucks used in testing the five bridges

Bridge	Truck 1 (lb.)			Truck 2 (lb.)		
	Rear axle	Front axle	Gross weight	Rear axle	Front axle	Gross Weight
Bridge X1	35,780	14,860	50,640	36,100	13,980	50,080
Bridge X2	37,440	14,800	52,240	39,000	14,200	53,200
Bridge X3	33,960	15,240	49,200	35,720	13,300	49,020
Bridge K1	33,960	15,240	49,200	35,720	13,300	49,020
Bridge K2	33,960	15,240	49,200	35,720	13,300	49,020

Test Procedure

For Bridges X1 and X2, 18 tests were conducted (see Table 2 for test description). During testing, ambient traffic was restricted on the bridges. To assess the quasi-static response, a single truck traveling in different lanes and shoulders at crawl speed was used. The dynamic response was recorded for a single truck traveling only in the driving lanes at speeds of 30 and 50 mph (48 and 80 km/h). First, Tests 1-9 were performed (tight condition), then bolts at the chosen locations were loosened, and Tests 10-18 were conducted (loose condition). In Bridge X1, bolts of the lower connections between the diagonal elements and the girders were loosened at the first diaphragm in the intermediate span (see

Figure 8). In Bridge X2, the lower connection bolts of four diaphragms (see Figure 10), in the negative moment region, were loosened to investigate the effects of lateral load distribution to the girders. The north side bolts were kept tight because they could not be accessed safely due to high-speed winds on the test day. During loosening, the strains in the web gaps were monitored continuously.

Due to the high volume of traffic on the three I-80 bridges, shutting down the traffic was not acceptable and, hence, it was not possible to restrict ambient traffic during testing. Thus, tests were conducted with the loaded trucks running at the traffic flow speed. All tests for the I-80 Bridges used a single test truck.

For Bridge X3, eight tests were conducted. Table 4 shows the condition of the bolts and truck speed and position during these tests. With the bolts tight, Tests 1-3 (tight condition) were conducted. After that, the lower connection bolts of the diaphragm diagonals at Locations EX3 and HX3 were completely loosened (see Figure 12). Next, Tests 4 and 5 (partial loose condition) were performed. Partial loosening is defined here as completely loosening the lower connection bolts of the exterior diaphragm panel. These tests allowed an investigation of the effects of loosening the bolts of only exterior panels on the web gap behavior of both exterior and interior girders. Later, the lower connection bolts of the interior panel at Location IX3 were loosened and Tests 6 and 7 (loose condition) were conducted.

Table 2. Test description for Bridges X1 and X2

	Number of trucks-speed	Bolts condition	Position of truck	
			Bridge X1	Bridge X2
Test 1	Single-crawl	Tight	West Shoulder	South Shoulder
Test 2	Single-crawl	Tight	West Lane	South Lane
Test 3	Single-crawl	Tight	East Lane	North Lane
Test 4	Single-crawl	Tight	East Shoulder	North Shoulder
Test 5	Single-30 mph	Tight	West Lane	South Lane
Test 6	Single-30 mph	Tight	East Lane	North Lane
Test 7	Single-50 mph	Tight	West Lane	South Lane
Test 8	Single-50 mph	Tight	East Lane	North Lane
Test 9	Two-crawl	Tight	West Shoulder and Lane	South Shoulder and Lane
Test 10	Single-crawl	Loose	West Shoulder	South Shoulder
Test 11	Single-crawl	Loose	West Lane	South Lane
Test 12	Single-crawl	Loose	East Lane	North Lane
Test 13	Single-crawl	Loose	East Shoulder	North Shoulder
Test 14	Single-30 mph	Loose	West Lane	South Lane
Test 15	Single-30 mph	Loose	East Lane	North Lane
Test 16	Single-50 mph	Loose	West Lane	South Lane
Test 17	Single-50 mph	Loose	East Lane	North Lane
Test 18	Two-crawl	Loose	West Shoulder and Lane	South Shoulder and Lane

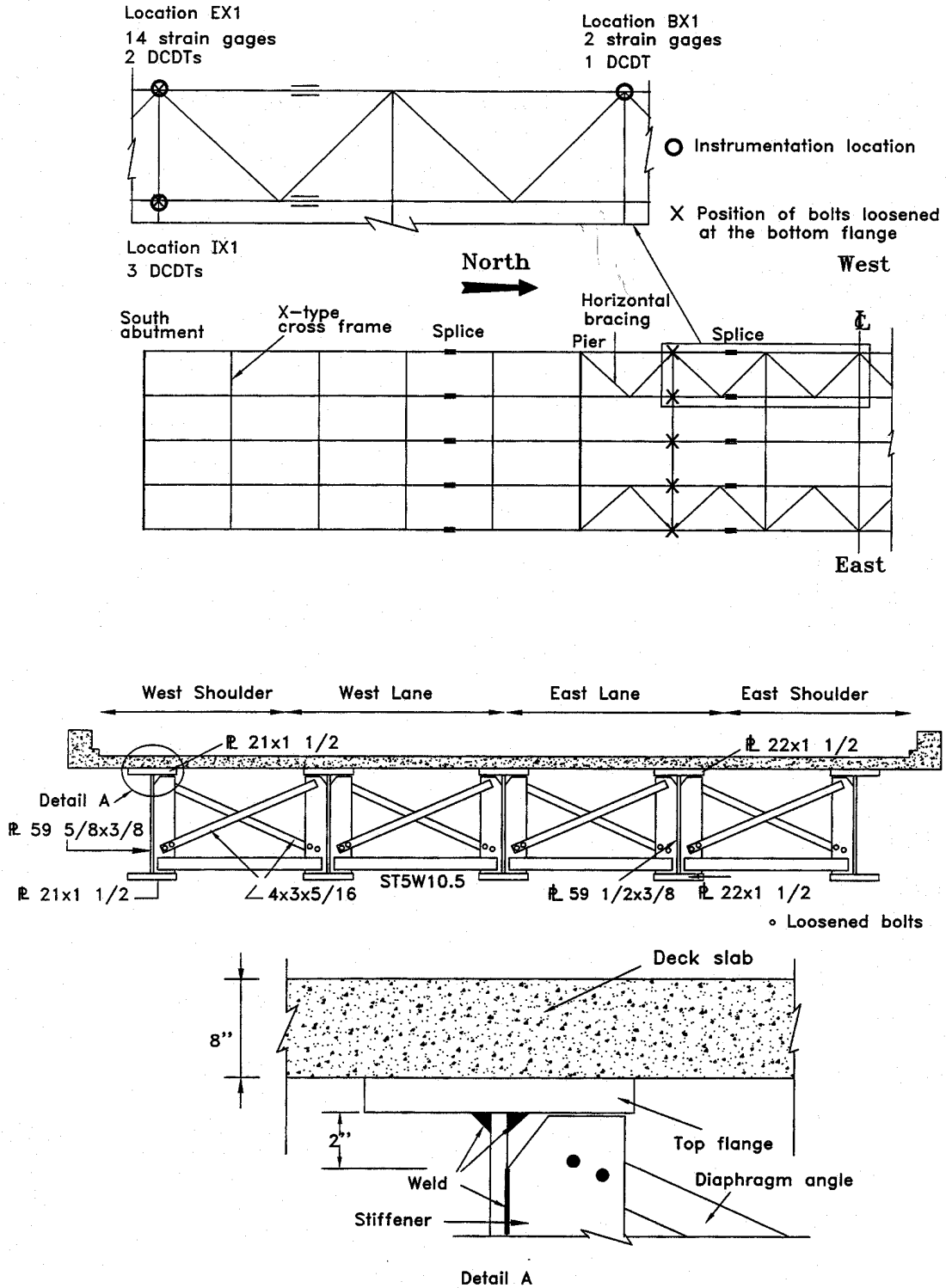

Figure 8. Schematic plan and cross section of Boone River Bridge (Bridge X1) showing instrumentation and loosened bolts locations

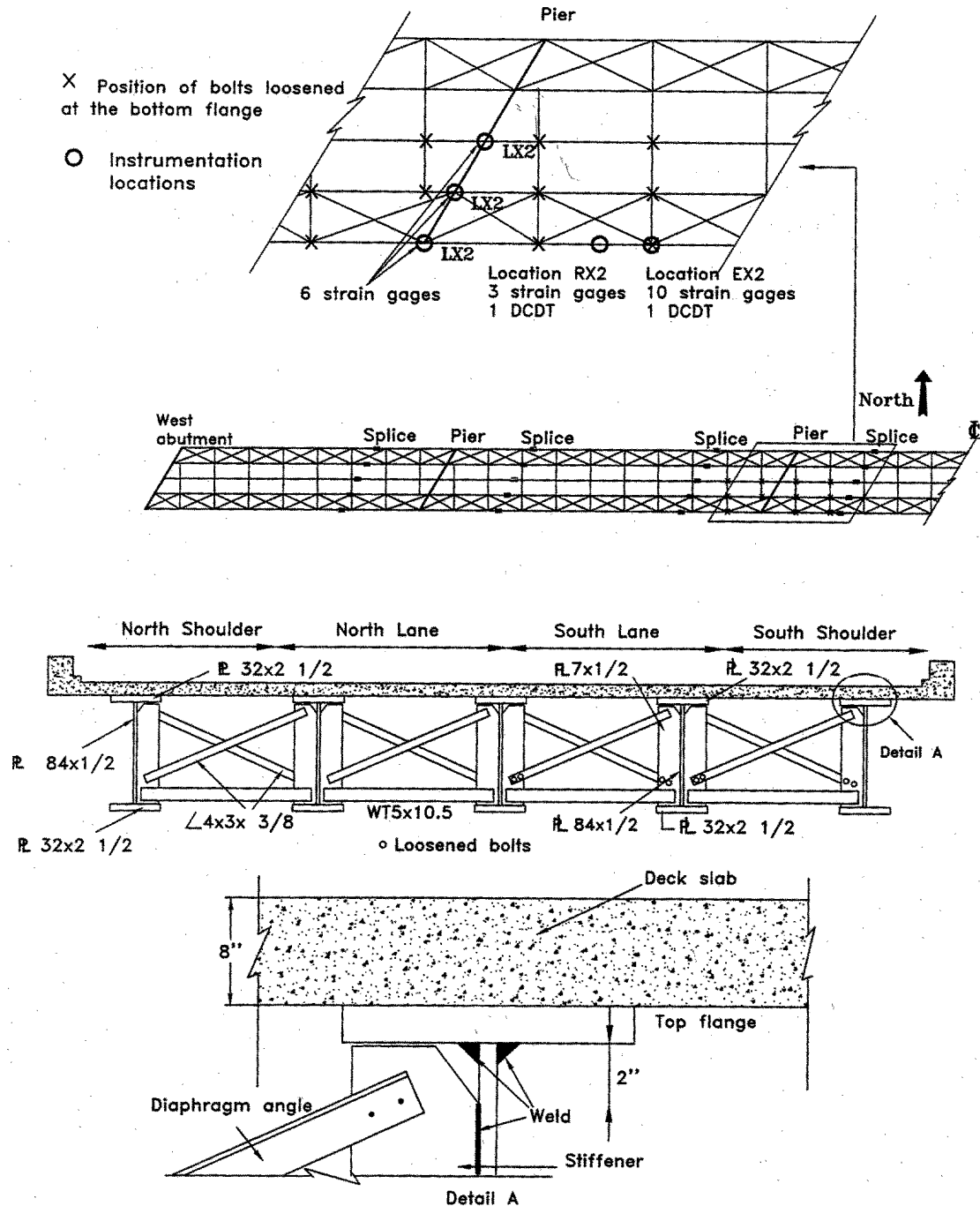

Figure 9. Schematic plan and cross sections of Des Moines River Bridge (Bridge X2) showing instrumentation and loosened bolts locations

To investigate the effect of loosening the bolts of all connections (upper and lower), the upper connection bolts of the exterior diaphragm panel at Location EX3 were loosened and Test 8 (called all bolts loose) was conducted.

Table 5 shows the arrangement of the seven tests performed on Bridge K1. All tests were conducted using a single truck. First, Tests 1-4 (tight condition) were conducted. After these tests, the six bolts of the upper connections between the diaphragms and the girders were loosened at the locations marked in

Figure 13. As the nuts were loosened, the diaphragm panel at Locations EK1 and AK1 rotated about a transverse axis passing through the lower connection bolts. This caused the top bolts of the upper connections to bear against their holes even with the nuts totally removed. Next, Tests 5-7 (loose condition) were conducted. Truck speed ranged from 40 to 60 mph (64 to 96 km/h).

For Bridge K2, ten tests were conducted as shown in Table 6. All tests were conducted using a single truck. With the bolts tight, Tests 1-3 (tight condition) were conducted. Next, the six upper-connection bolts that attach the exterior diaphragm panel to the stiffeners of both the exterior and interior girders were loosened (see Figure 14). Tests 4-6 (partial loose condition) were conducted. Later, the upper connection bolts in three interior panels through the fifth girder were loosened and Tests 7-9 (loose condition) were conducted. Afterwards, the lower connection bolts of the exterior diaphragm panel between the exterior and interior girders at Location EK2 were loosened. Then, Test 10 (all bolts loose) was conducted. Truck speed ranged from 45 mph (72km/h) to 65 mph (104 km/h) during different tests. Additional data were collected during passage of heavy trucks on the bridge.

Upon completion of tests at individual bridges, all bolts were tightened back to their original state.

Instrumentation

Two types of instrumentation were used: displacement transducers and strain gages. Trans-Tek series 240 DC-DC displacement transducers (DCDT) were used to measure displacements.

These units consist of a precision linear variable differential transformer, a solid state oscillator, and a phase sensitive demodulator. The core, when displaced axially within the core assembly, produces a voltage change in the output directly proportional to the

Table 4. Test description for Bridge X3

	Number of trucks- speed	Bolts condition	Truck position
Test 1	Single-60 mph	Tight	South Lane
Test 2	Single-55 mph	Tight	North Lane
Test 3	Single-60 mph	Tight	Straddling between Lanes
Test 4	Single-60 mph	Partial loose	South Lane
Test 5	Single-64 mph	Partial loose	North Lane
Test 6	Single-60 mph	Loose	South Lane
Test 7	Single-55 mph	Loose	North Lane
Test 8	Single-60 mph	All bolts loose	North Lane

Table 5. Test description for Bridge K1

	Number of trucks- speed	Bolts condition	Truck position
Test 1	Single-40 mph	Tight	South Lane
Test 2	Single-40 mph	Tight	Intermediate Lane
Test 3	Single-55 mph	Tight	North Lane
Test 4	Single-55 mph	Tight	Straddling between South and Intermediate Lanes
Test 5	Single-50 mph	Loose	South Lane
Test 6	Single-60 mph	Loose	Intermediate Lane
Test 7	Single-50 mph	Loose	North Lane

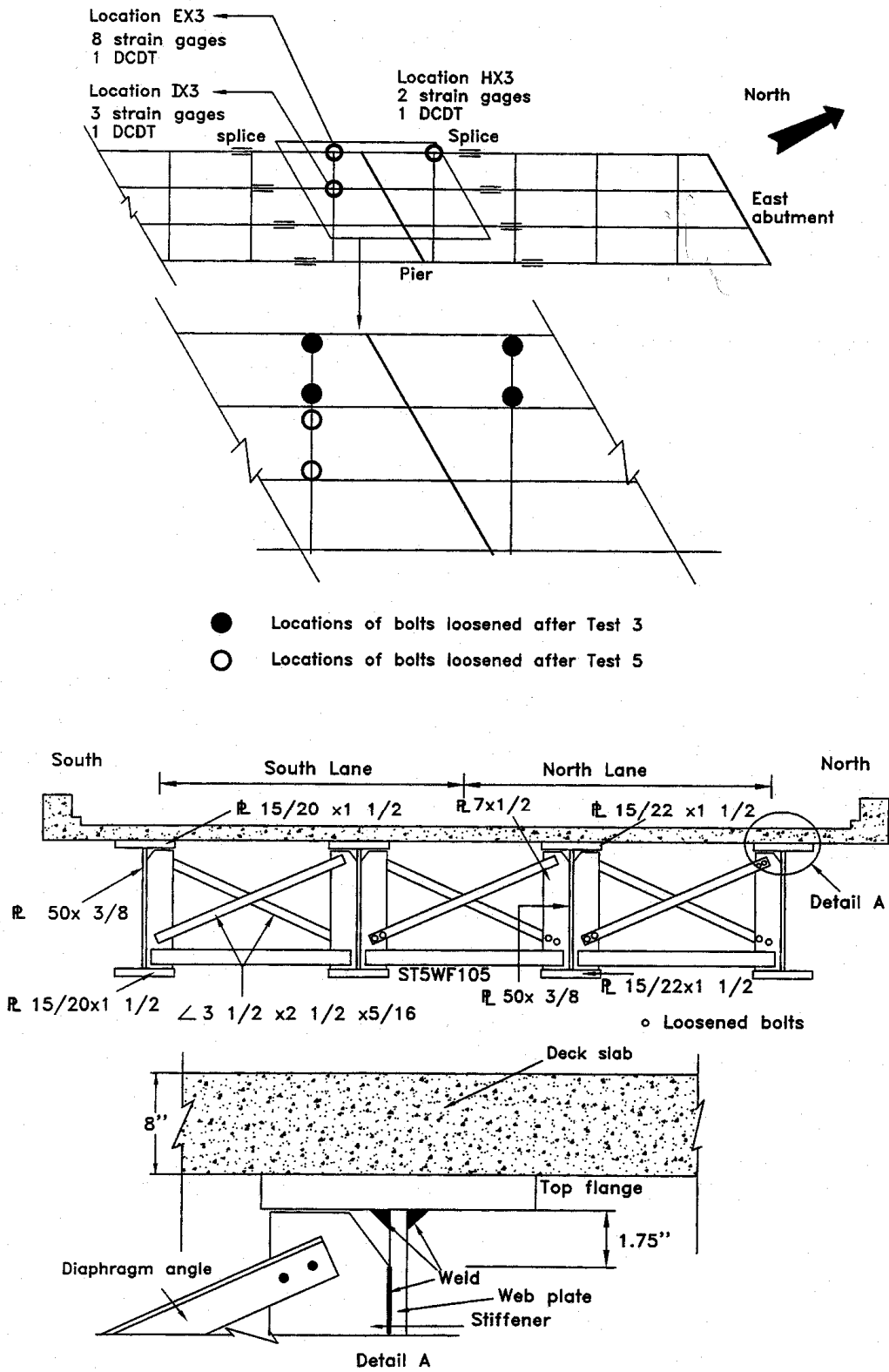

Figure 10. Schematic plan and cross sections of Bridge no. 7804.8L080 (Bridge X3) showing instrumentation and loosened bolts locations

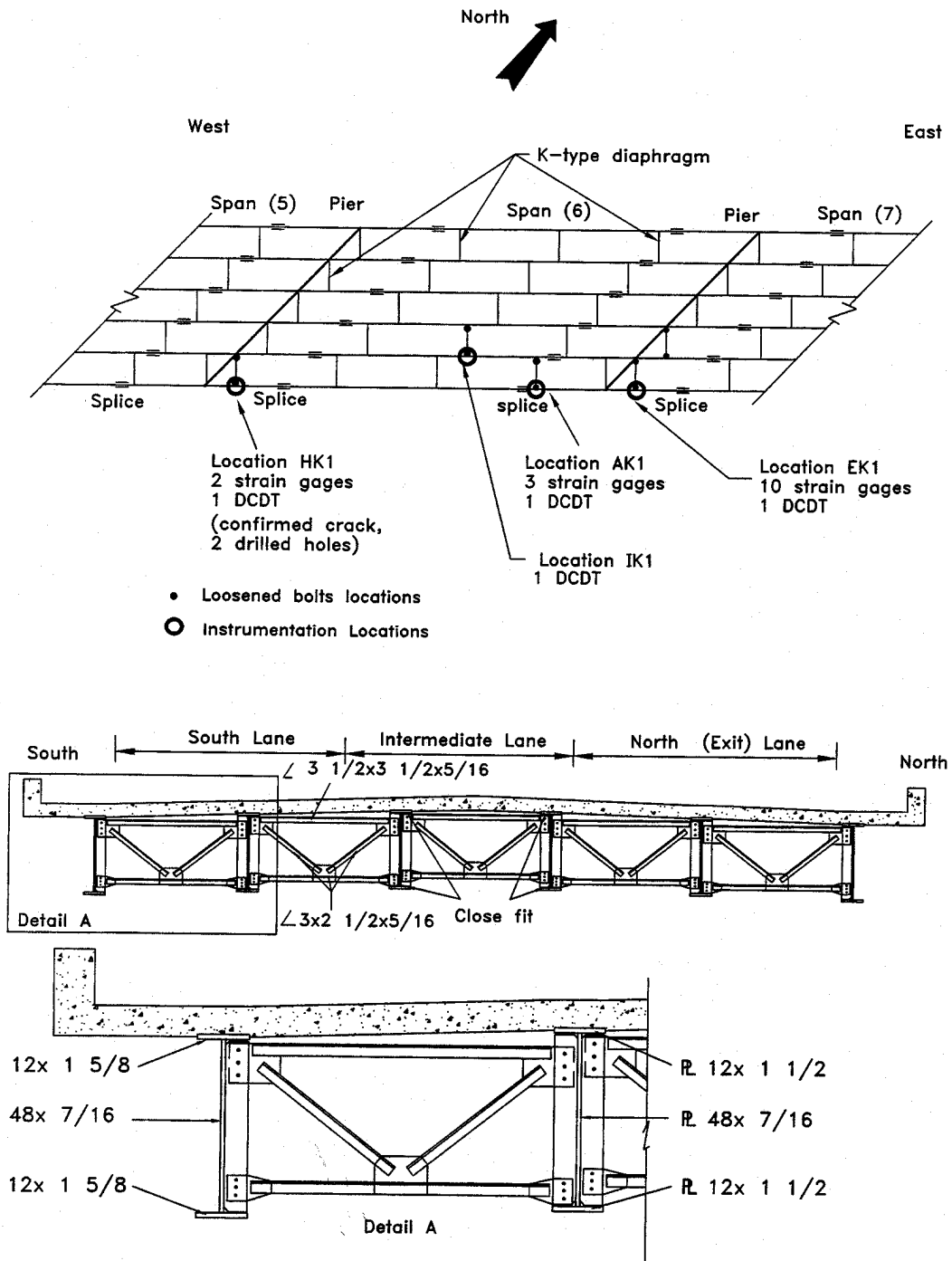

Figure 11. Schematic plan and cross sections of Mosquito Creek Bridge (Bridge K1) showing instrumentation and loosened bolts locations

Table 6. Test description for Bridge K2

Test	Number of trucks- speed	Bolts condition	Truck position
Test 1	Single-55 mph	Tight	South Lane
Test 2	Single-55 mph	Tight	Intermediate Lane
Test 3	Single-60 mph	Tight	North Lane
Test 4	Single-55 mph	Partial loose	South Lane
Test 5	Single-65 mph	Partial loose	Intermediate Lane
Test 6	Single-45 mph	Partial loose	North Lane
Test 7	Single-65 mph	Loose	South Lane
Test 8	Single-60 mph	Loose	Intermediate Lane
Test 9	Single-55 mph	Loose	North Lane
Test 10	Single-65 mph	All bolts loose	South Lane

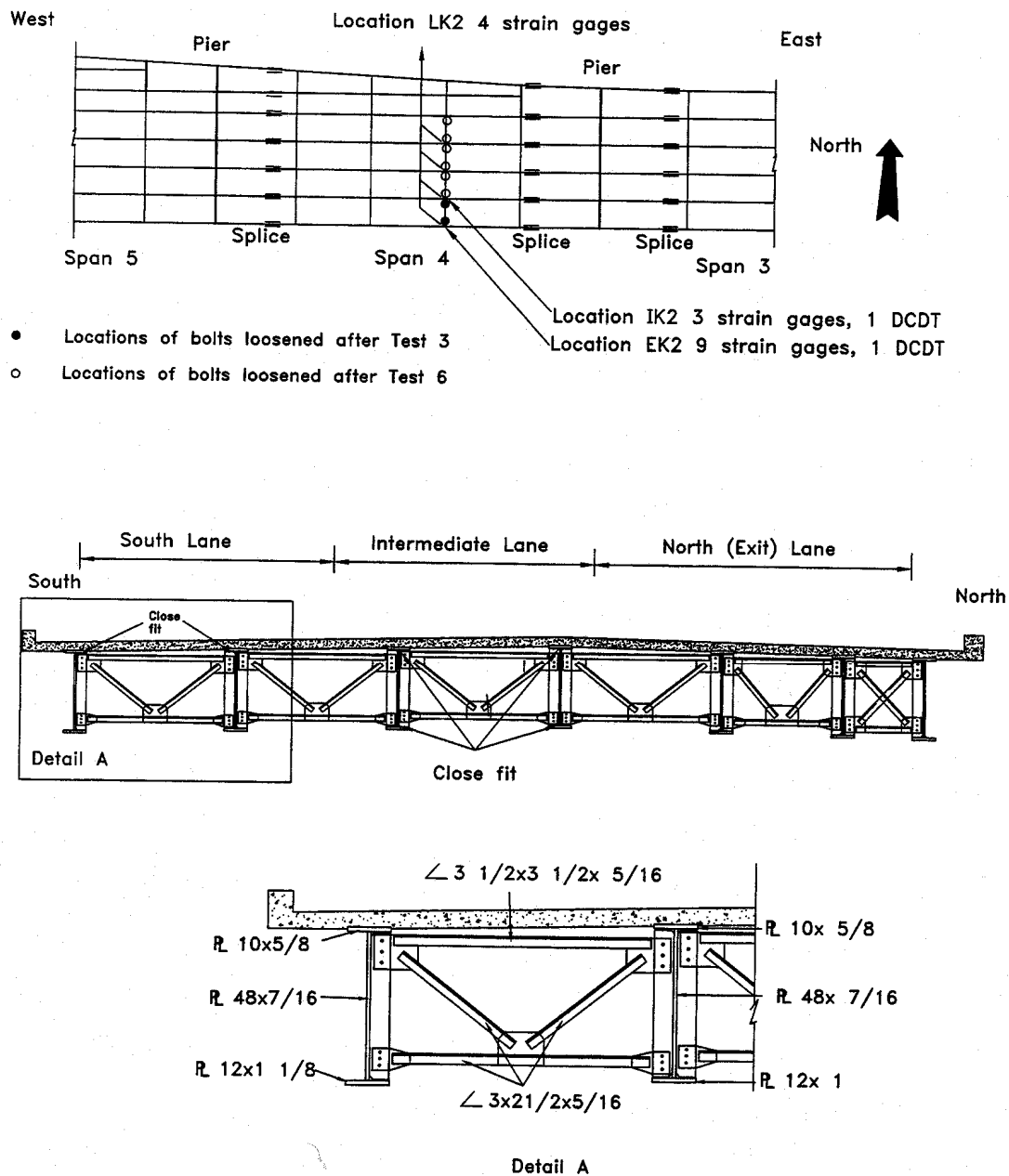

Figure 12. Schematic plan and cross sections of IA-192 Bridge showing instrumentation and loosened bolts locations

displacement. These units provided excellent linearity, infinite resolution, and high sensitivity. Confidence of accuracy was 0.0003 ± 0.0001 in. (0.007 ± 0.003 mm). The transducers were mounted using magnetic holders. Magnetic isolation of the transducer to reduce any effects of the mounting magnet on the coil was accomplished by using aluminum blocks for attachment of the transducer to the magnet. The cores were spring loaded to provide constant contact pressure at the measurement location.

Foil strain gages were mounted at locations that were determined to be critical in evaluating the effects of loosening the bolts of the diaphragm connections. All strain gages were manufactured by the Micro-Measurements and Instruments Division of the Measurements Group, Raleigh, North Carolina. A common characteristic of the gages was self-temperature compensation with a resistance of 350 ohms. Surface preparation and strain gage bonding was done per manufacturer specifications. Final protective coatings, rubber sealant, and foil tape sealed with rubber were applied to protect against moisture.

Data from the displacement transducers and strain gages were collected, processed and stored using a data acquisition system manufactured by the Optim Electronics Corporation. The system was a 5108DC Megadac with control and data storage provided by a laptop computer and an IEEE-488 connection. The system was set to a pre-trigger waiting state and instruments were electronically balanced before collecting data. The data collection process was initiated manually when a vehicle approached the bridge. During data collection, all instruments could be monitored to determine if any channel was having signal problems. The data scan rate was set to 50 Hertz for crawl speed tests and 100 Hertz for the other speeds. Data collection rate of 100 Hertz means one complete scan of all instruments occurred approximately every 0.01 second. The time interval between channel readings was four μ seconds. The time duration of the data collection was user-defined and manually terminated after the desired data had been collected.

Measurements and Locations

Before each bridge was field tested for this study, a three-dimensional finite element model was constructed using ANSYS, a commercial finite-element-software package. The Iowa DOT

provided the design and construction drawings. These drawings as well as measurements taken during field visits prior to testing were the primary sources for modeling. Since several diaphragm/plate girder connections exist in the negative moment region of each bridge, it was desired to instrument the one with the greatest potential for developing fatigue cracks due to out-of-plane distortion. The finite element model was utilized to determine at which diaphragm connection the greatest distortion develops. Forces in the diaphragm elements are the main cause of the out-of-plane distortion. Forces in the diaphragm elements were computed from static analyses considering wheel live loads.

Sensor locations were primarily chosen at the intact web gaps with diaphragm connections that produced the maximum out-of-plane moment in the web plate at the connection gap. The finite element analysis showed that these locations always occurred at exterior girders. These locations are called EX1, EX2, EX3, EK1, and EK2 for Bridges X1, X2, X3, K1, and K2, respectively. It should be noted that no intermediate cross frame exists in the negative moment regions in Bridge K2; therefore, the tested web gap (EK2) was in a positive moment region. The connection plate was not welded to the top flange in this region.

Typical instrumentation details for these gaps in X- or K-type diaphragm bridges are shown in Figure 15. Each location was instrumented with 8 to 14 strain gages and one or two displacement transducers to record the following: (1) strains in the web gap region due to out-of-plane deformation, (2) strains in diaphragm diagonal(s), (3) girder flange and web strains remote from the local effect of the out-of-plane distortion, and (4) amount of out-of-plane distortion. It must be noted that strains in the web gap regions would be expected to be highest at the toe of the top flange to web weld; however, it was not possible to place strain gages exactly at these locations. Strain gages were placed as close as possible to the vertical stiffener with the centerline of the gage within 0.5 in. (13 mm) from the edge of the stiffener plates. The top gages were within 0.63 in. (16 mm) from the bottom of the top flange. Closer distances were not possible because of the weld connecting the web to the top flange. In some locations, additional gages were used to allow extrapolating the recorded strains to obtain the values at the most critical locations (inside the gap at the weld toes).

In addition, for bridges where holes were drilled, sensors were located at the cracked web gap (with diaphragm connection in the negative moment region) with the greatest out-of-plane moments. These are Locations HX3 and HK1 for Bridges X3 and K1, respectively. Figure 16 is a photo for Location HX3 with horizontally oriented cracks and drilled holes. In these locations (HX3 and HK1), the horizontal distribution of the out-of-plane distortion strains and the horizontal out-of-plane displacement were measured. Web gaps of interior girders in the negative moment regions are also susceptible to fatigue cracking. Therefore, four locations were instrumented: IX1, IX3, IK1, and IK2, respectively. At these locations, the out-of-plane distortion was recorded. Further, the strain distribution in the web gap region due to the out-of-plane distortion was measured (using at least three strain gages) in all of them except Location IX1. For Location IX1, two vertically oriented displacement transducers were attached on either side of the web to measure the relative vertical displacement between the flange and the web.

Three other locations were instrumented to record the strains and the out-of-plane distortion in small web gaps. Location BX1 is a web gap near the bottom flange at a positive moment region of an exterior girder in Bridge X1. Location RX2 is a web gap without diaphragm connection at the top flange in the negative moment region. Location AK1 is a web gap with a diaphragm connection in the negative moment region of an exterior girder. Location BX1 was used to assess the possibility of fatigue cracking near the bottom flanges in positive moment regions, whereas measurements at Location RX2 provided reference for strains and displacements in the absence of diaphragms and, consequently, their forces and connections. Clearly, readings of the gages at that location would not be affected by applying the method (there is no diaphragm connected to this web gap); hence, their readings were only recorded in the loose condition.

Also, it was desired to gather information about the change in the global behavior due to the application of the proposed method, specifically, how the proposed method would affect the transverse distribution of vertical loads. Therefore, the longitudinal bending strains in girder flanges were collected in two bridges: (1) a skew bridge with X-type diaphragms at an intermediate pier section (Location LX2), and (2) a non-skew bridge with K type diaphragm in a positive moment region (Location LK1).

Data Analysis

After the field data were collected, they were stored on a laptop computer and transported to the laboratory where they were reduced and plotted. Comparative data plots were generated using commercial software. Of primary interest was the effect of the proposed retrofit method on the strain distribution and magnitude in the web gap region, on the strain range in the web gap region, on the out-of-plane distortion at the web gap region, on the forces in the diaphragm elements, and on the lateral load distribution of gravity live load in the girders at a given cross section. The strains in the web gap region and the strain ranges were obtained from the strain gage instrumentation. The strains were plotted for each test. Strain plots were used to compute the maximum strain and strain range occurring during different tests. Further, stress and stress ranges were computed by multiplying the corresponding strain and strain ranges by the modulus of elasticity. Stress range is an essential factor for determining fatigue life of welded joints as research showed that fatigue strength of welded joints is only governed by the applied stress range regardless of the type of stress or stress ratio [11]. The diaphragm element forces were computed by multiplying the average of the strain readings of the gages attached to the diaphragm diagonals by the modulus of elasticity. The effect of loosening bolts on the transverse vertical load distribution was obtained from the strain gages attached to the girders at the pier or at the positive moment region.

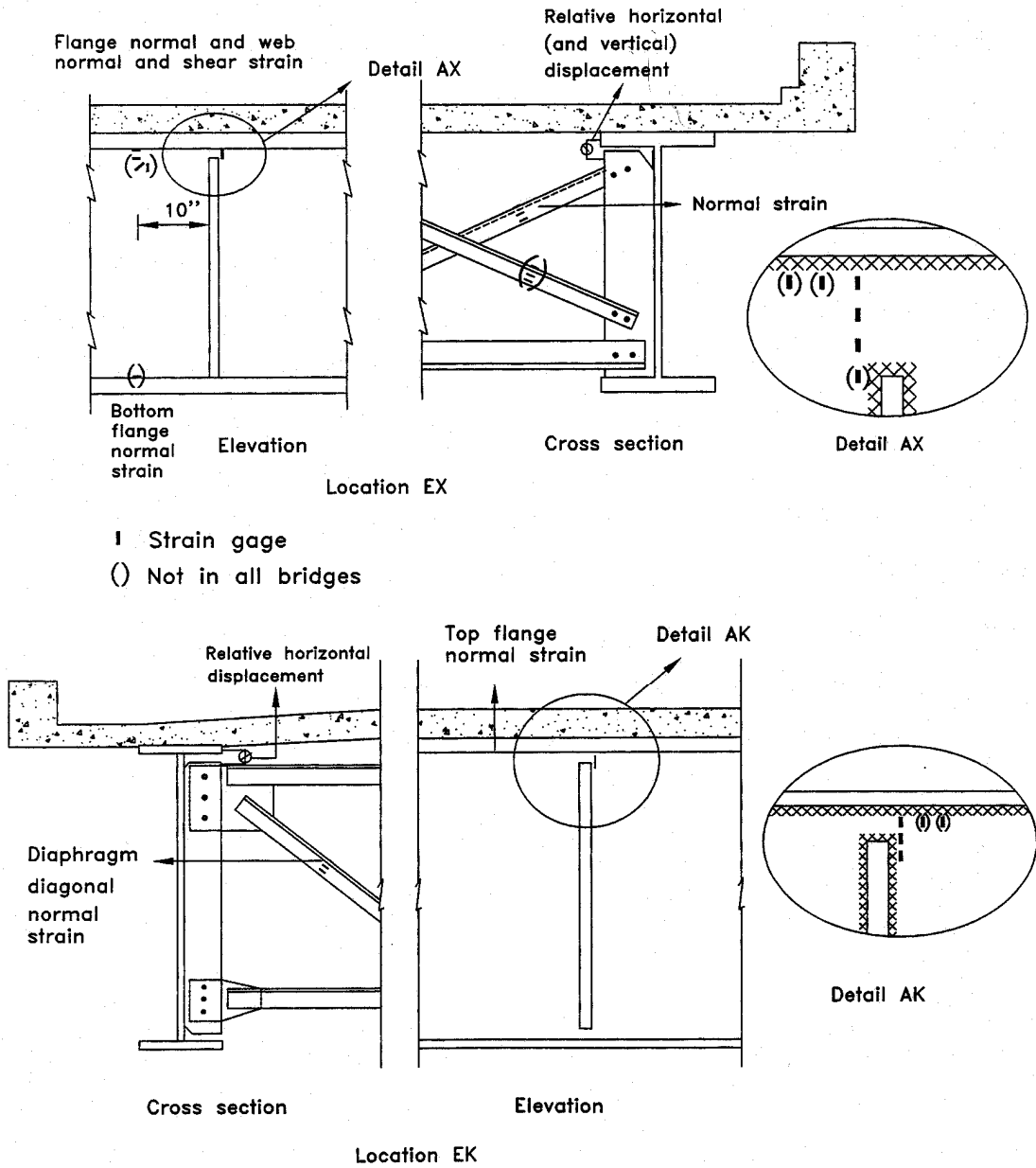
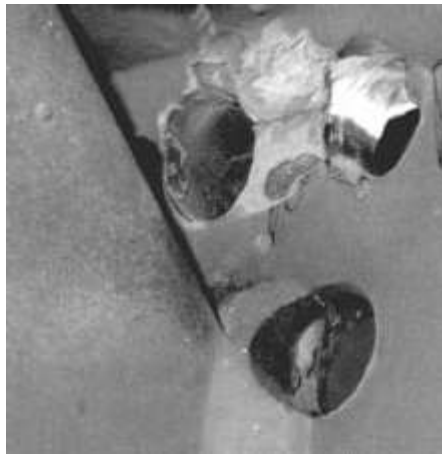

Figure 13. Typical EX and EK instrumentation details



(a) Overview



(b) Drilled holes and cracks

Figure 16. Crack and drilled holes at Location HX3

FIELD TESTS RESULTS AND DISCUSSION

In the following sections, the effects of loosening the bolts on the web gap strains, out-of-plane distortion (horizontal deflection), diaphragm diagonal element forces, and girder lateral load distribution are presented. The potential of the proposed retrofit method to prevent fatigue cracking in the web at the diaphragm/plate girder connection is evaluated. Other design aspects that must be considered before implementing the method are also described.

Local Effect of the Method

Web Gap Strains

X-Type Diaphragm Bridges

Figure 17 shows the strain readings of the four gages installed in the web gap at Location EX1 during Test 5. Like all strain plots, it is characterized by a single maximum value followed by a small rebound strain. During Test 5, the maximum recorded strain for Gage 1 was 160 micro-strain (4.64 ksi or 31.97 mPa). This figure illustrates how the strain range is estimated. Strain range is an absolute value with no associated sign. After graphically finding the strain range, the stress range is estimated as described in the previous chapter.

The strain in the web gap region showed variation with truck speed. When tests with different truck speeds were conducted, tests with a 30-mph (48km/h) speed had the highest strains. The strain in the web gap, however, showed greater variation with transverse truck position. Figures 16 and 17 show the effect of transverse truck position on the vertical profile of the maximum strains occurring in the web gap region of Location EX1 and Location EX2, respectively, for tests with a single truck traveling at crawl speed. Clearly, the strain distribution shows bending of the web due to the out-of-plane distortion. It should be noticed that although the web-gap geometrical configuration is nearly the same at both locations (different bridges), the maximum strains differ significantly. This implies clearly

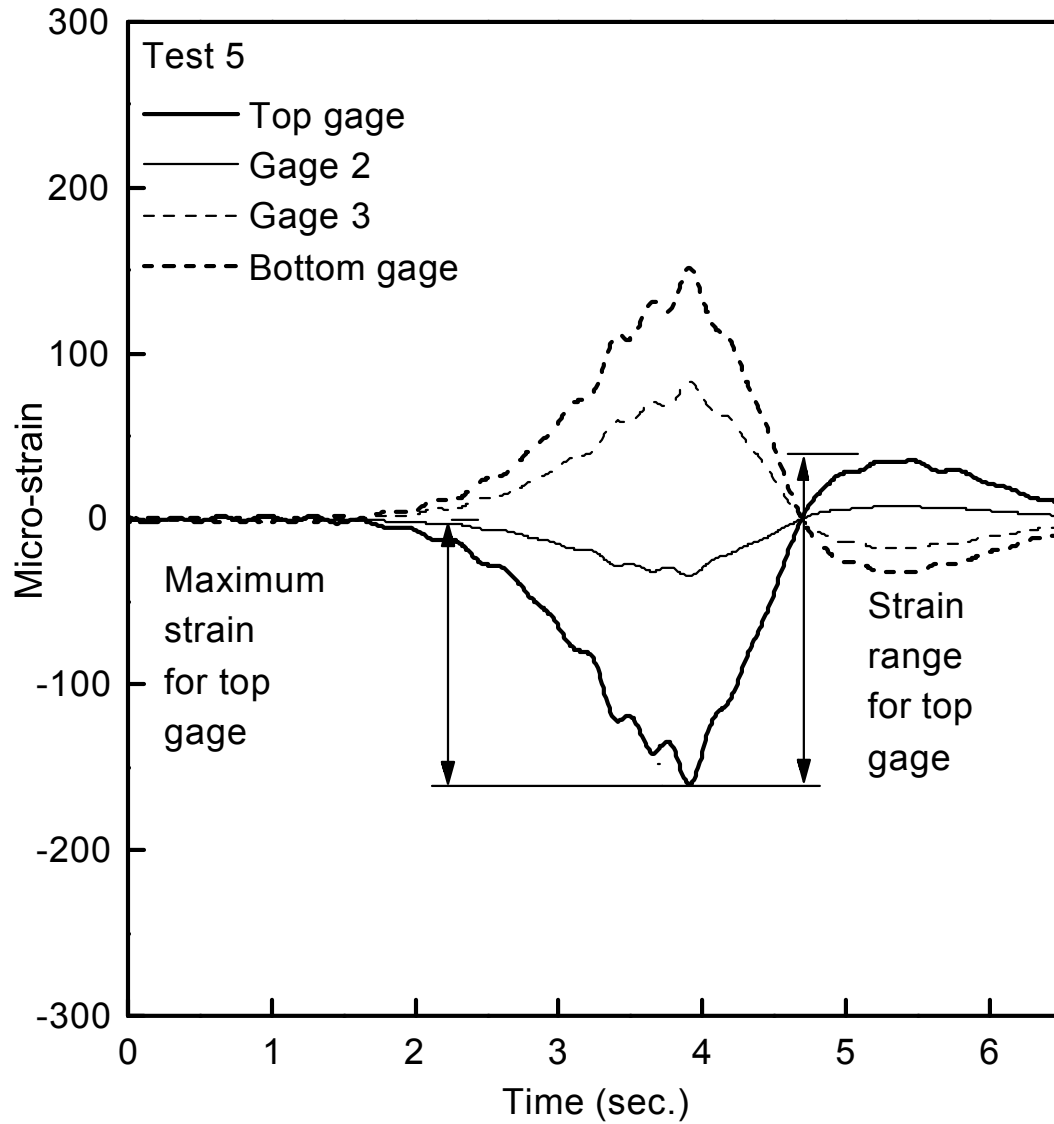

Figure 17. Strain recorded in the web gap region at Location EX1 during Test 5

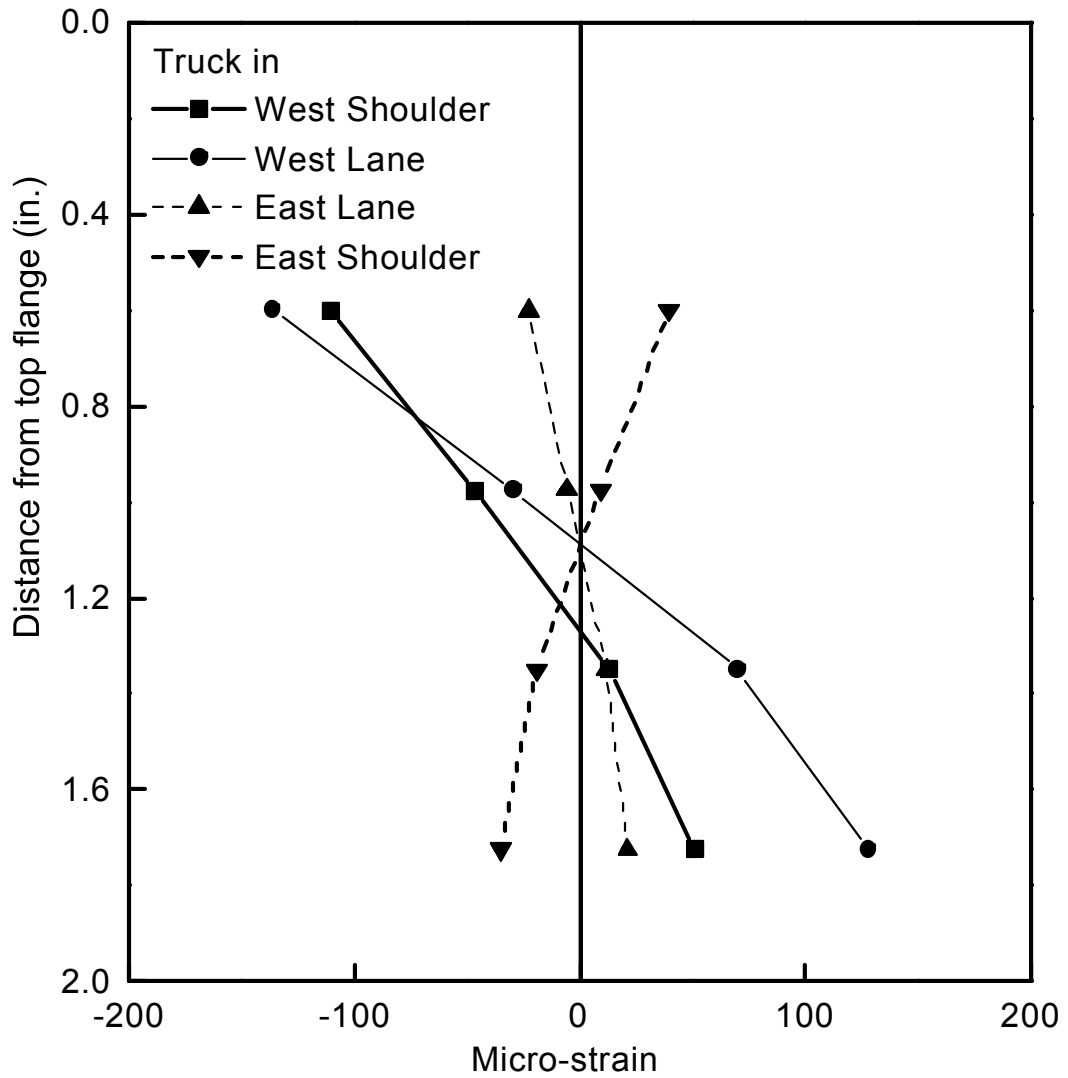

Figure 18. Vertical profile of the maximum strains in the web gap at Location EX1 during Tests 1-4

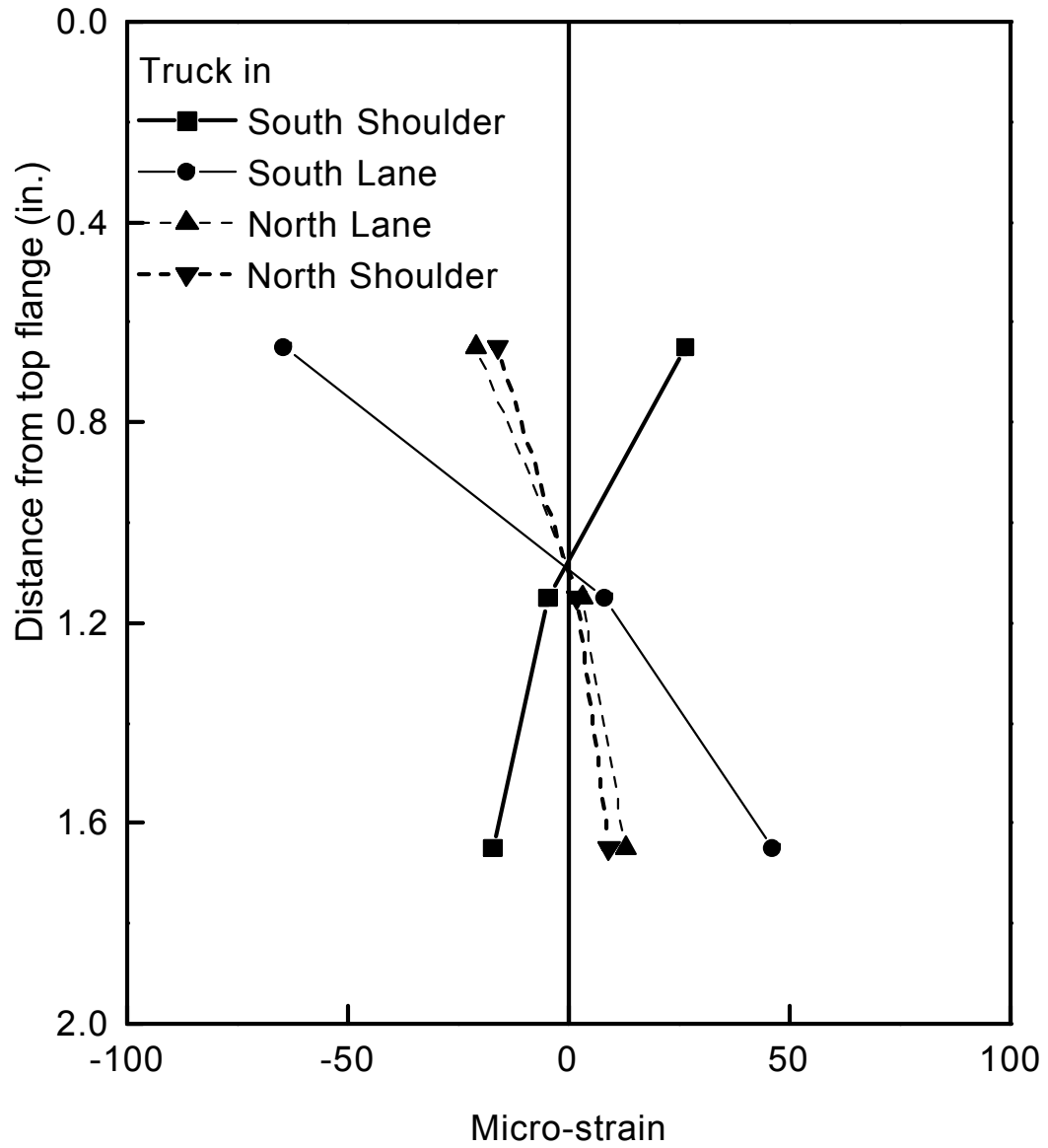

Figure 19. Vertical profile of the maximum strains in the web gap at Location EX2 during Tests 1-4

that the strains and stresses, in addition to being location dependent, are bridge dependent. At Location BX1 near the bottom flange in the positive moment region, the strain distribution in the web gap is shown in Figure 20. The distribution did not exhibit bending behavior. The values of these strains are less than 10% of those at Location EX1 in the negative moment region, explaining why it is more likely that a web gap in the negative moment region would crack.

At Location HX3 (with drilled holes), strains and strain ranges in the web gap were slightly higher than the corresponding values at Locations EX3 and IX3 (150, 128, and 140 micro-strains or 4.35, 3.71, and 4.06 ksi (29.97, 25.56, and 27.97 mPa) for HX3, EX3, and IX3, respectively). This implies that drilling holes might be insufficient to prevent crack re-initiation. At Location RX2 (with no diaphragm connection), the strain distribution shows a very slight bending behavior (see Figure 21) with values significantly smaller than those in locations with diaphragm connection (EX1, EX2, EX3, HX3, and IX3).

After loosening the bolts, the strains at all locations with diaphragm connections drop significantly. Figure 22 shows a comparison between the vertical profile of the strain in the web gap at Location EX3 during Test 2 (tight), Test 5 (partial loose), Test 7 (loose), and Test 8 (all bolts loose). Obviously, the web gap strains at Location EX3 (and similarly all gaps with diaphragm connections) were reduced upon loosening the bolts. However, the distribution still reflects out-of-plane bending behavior of the web gap. Loosening the exterior diaphragm panel lower bolts only (partial loose) had nearly the same effect as loosening both exterior and interior panel lower bolts (loose) or loosening the exterior and interior panel lower and upper bolts (all bolts loose) on the exterior girders web gap strains. For an interior girder (Location IX3), however, a significant reduction in the web gap strains occurred after loosening the diaphragm bolts of the interior panel (i.e. between partial loose and loose condition). Figure 23 illustrates that for Test 2 (tight), Test 5 (partial loose) and Test 7 (loose) with the truck travelling in the North Lane.

To illustrate the local effect of the out-of-plane distortion and the effect of the proposed method, the horizontal distribution of the resulting strains is plotted in Figure 24 for Locations EX3 and HX3 for both tight and loose conditions. With the bolts tight, the

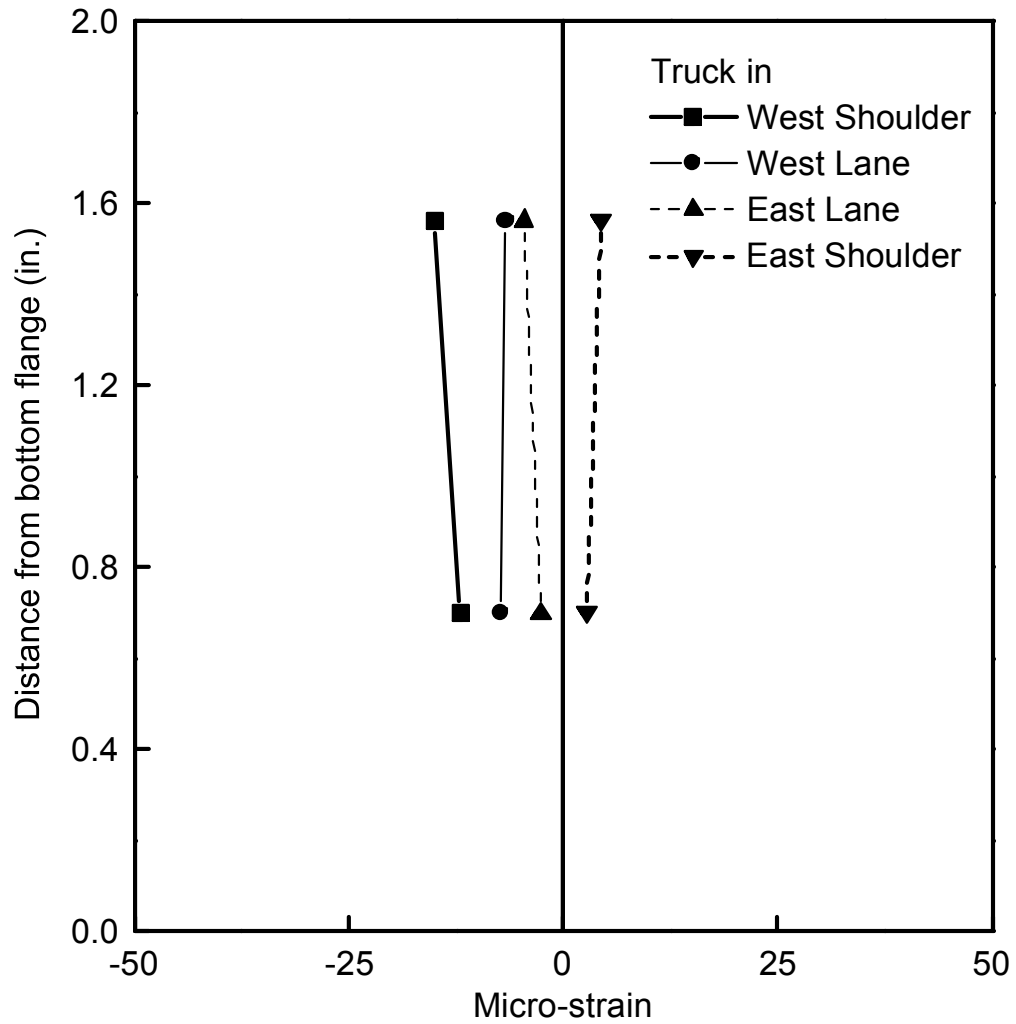

Figure 20. Vertical profile of the maximum strains in the web gap at Location BX1 during Tests 1-4

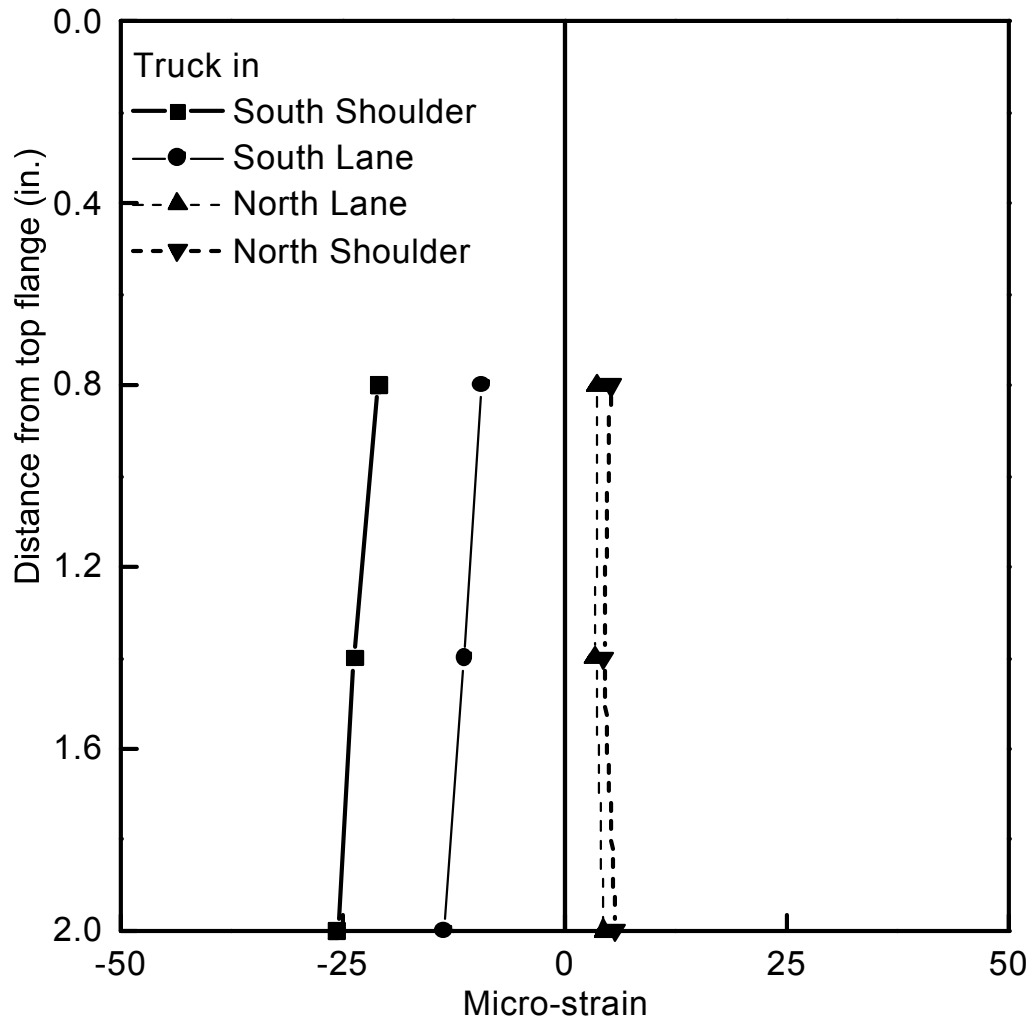

Figure 21. Vertical profile of the maximum strains in the web gap at Location RX2 during Tests 10-13

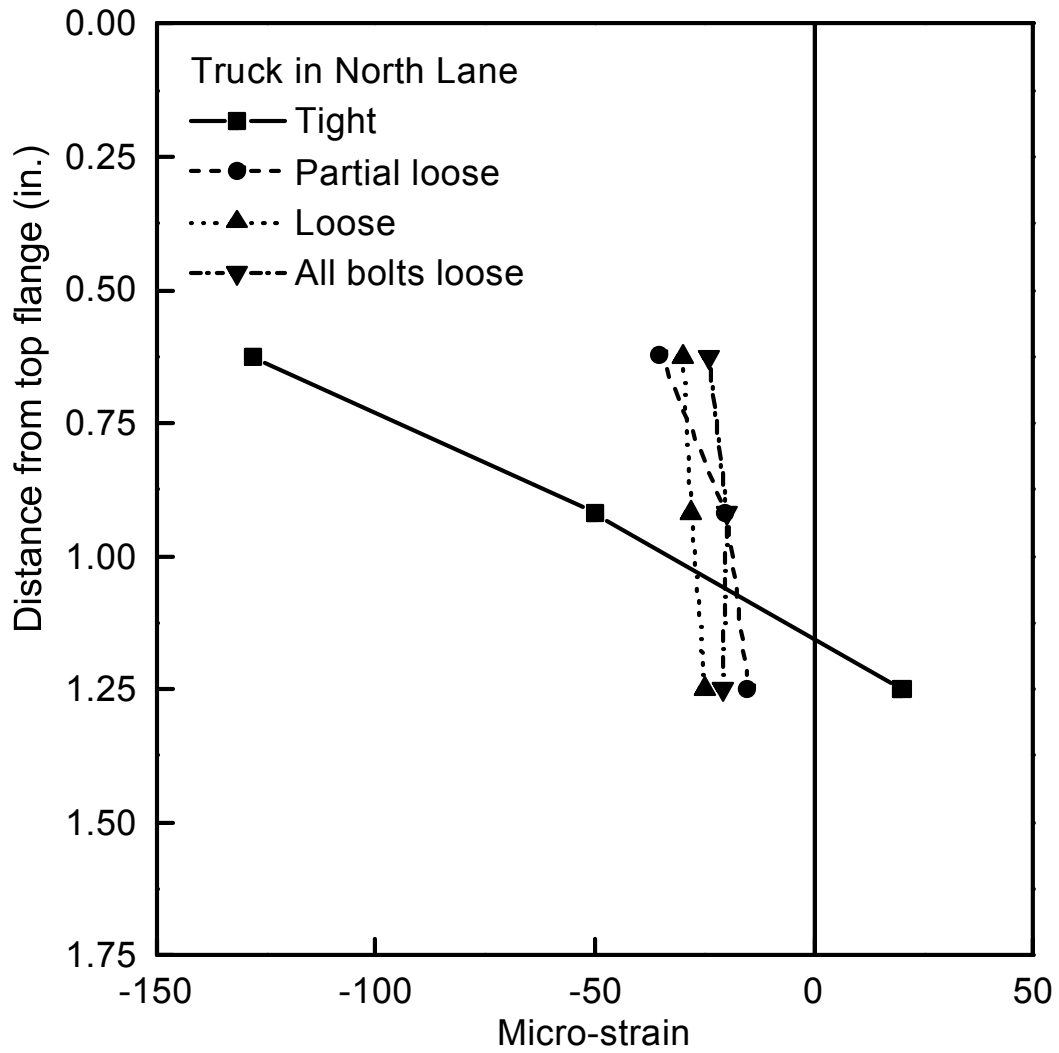

Figure 22. Comparison among maximum strains at Locations EX3 during Test 2 (tight), Test 5 (partial loose), Test 7 (loose) and Test 8 (all bolts loose)

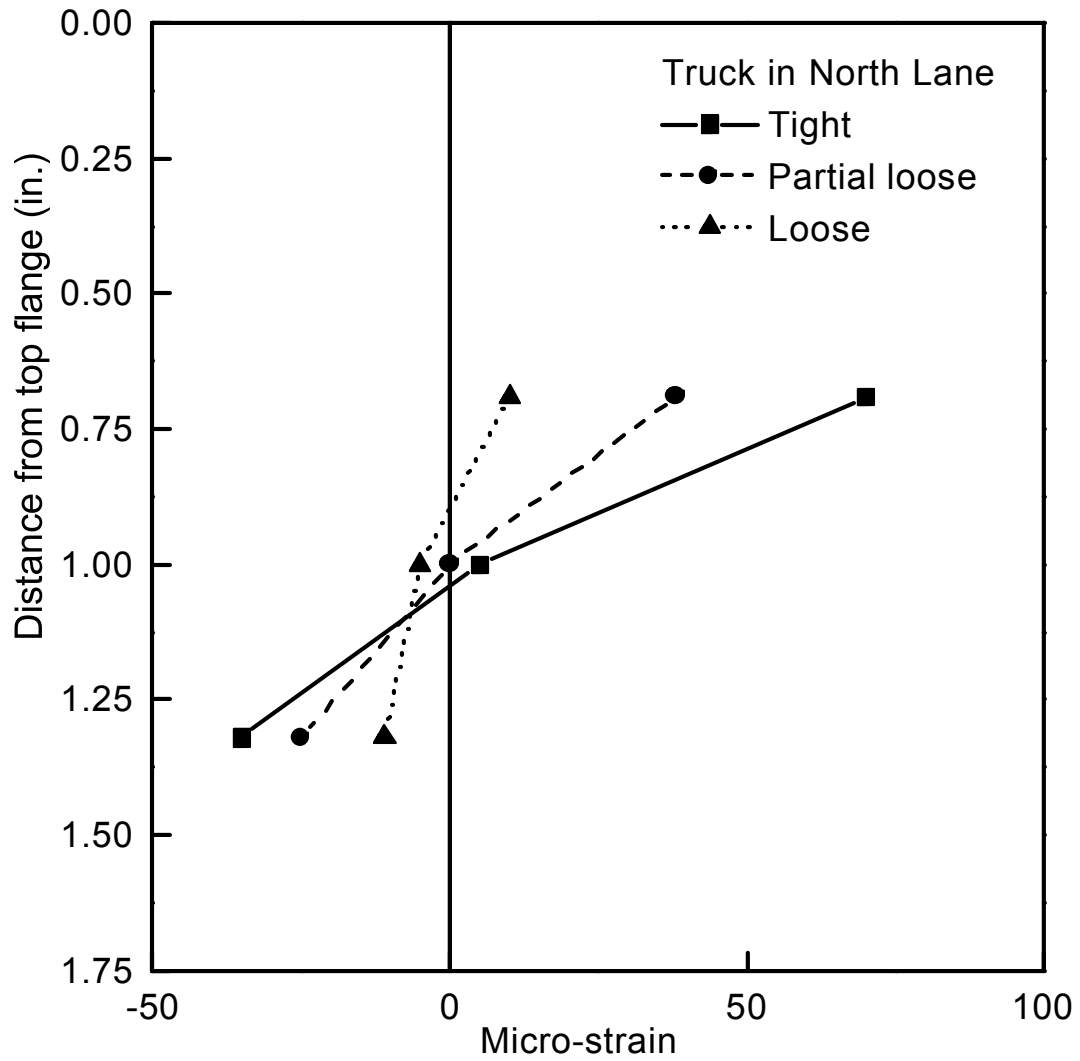

Figure 23. Comparison among strains before and after loosening the bolts at Location IX3

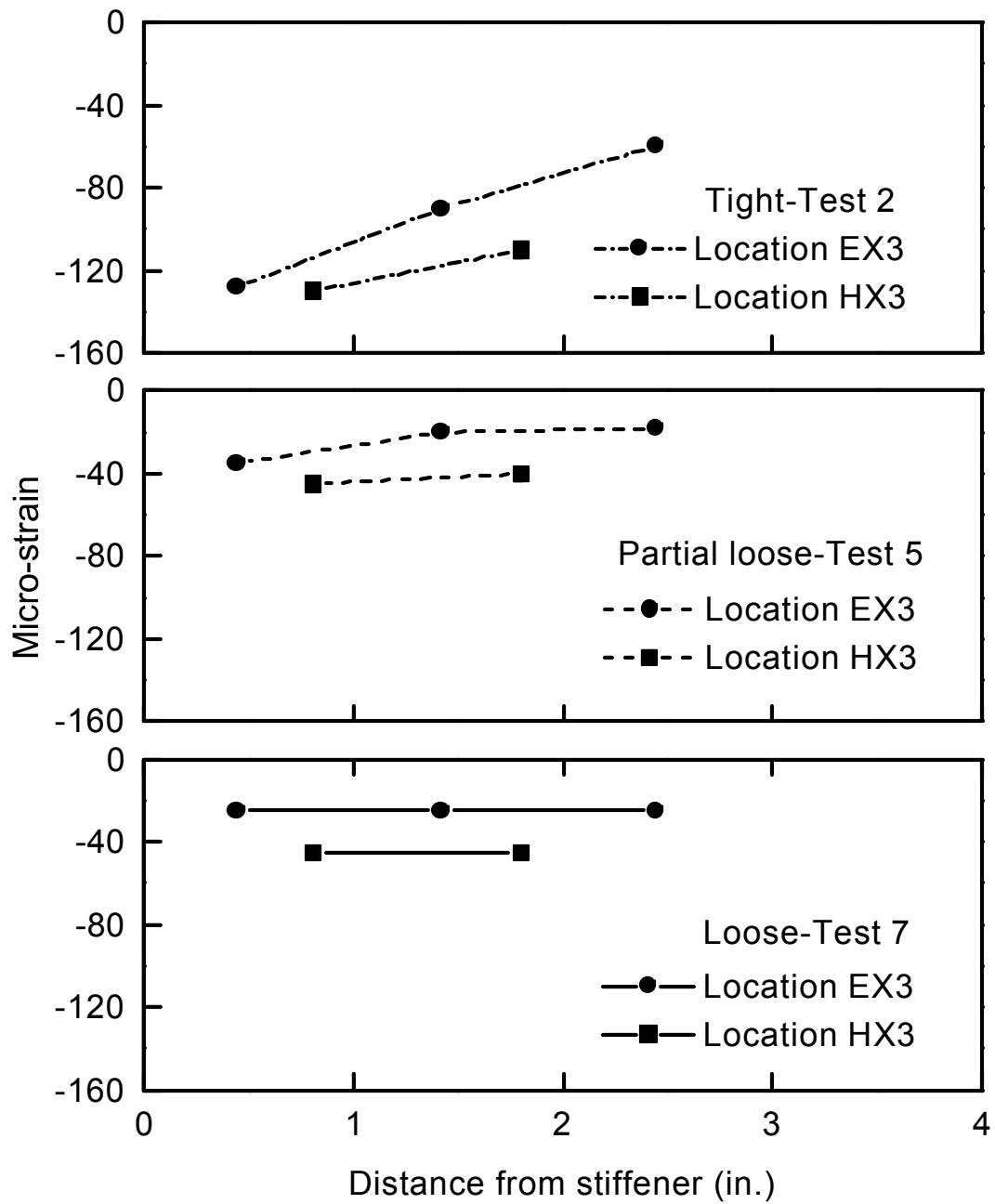

Figure 24. Horizontal profile of maximum vertical strains in the web gap of Locations EX3 and RX3 during Tests 2 (tight), 5 (partial loose), and 7 (loose)

strains gradually increased towards the stiffener plate. After loosening the bolts, however, the strain distribution was nearly constant, implying that the local effect had diminished. Linear extrapolation of the recorded strains at Location EX3 showed that a maximum projected strain of 220 and 180 micro-strains, or 6.38 and 5.22 ksi (43.96 mPa, 35.97 mPa), would have occurred at the longitudinal flange to web weld toe and stiffener to web weld toe, respectively. That explains why most web cracks resulting from out-of-plane distortion initiate at either of these two locations.

The stress ranges were computed from different tests in which a single test truck was used, and the maximum value (directly without extrapolation) for each location is shown in Table 7. The table also gives the values for the stress ranges after applying the proposed method as well as the reduction percentage in the stress ranges. The values for the tight condition listed in this table may be small compared to those reported in the literature (for example, those presented in Ref. 5) because those were extrapolated inside the web gap and were due to truck weights double those in the current study. Considering the reduction percentages in the stress range, fatigue life of the web gap detail could increase at least seven times (note that the approximate fatigue life is inversely related to the cubic power of the stress range [4]). The stress ranges in web gaps with loose diaphragm connection bolts (0.35 to 1.63 ksi, or 2.41 to 11.23 mPa) were close to that in the web gap without a diaphragm connection RX2 (1.02 ksi or 7.03 mPa). Hence, fatigue life at a web gap with loose diaphragm connection should be nearly the same as that in a web gap without any connection.

K-Type Diaphragm Bridges

The vertical profiles of the maximum web-gap strains at Location EK1 during tight condition tests (Tests 1-3) are shown in Figure 25. As is the case with X-type diaphragm bridges, the figure indicates the bending behavior of the web gap and the variation of the strain profile with the transverse truck position. In the tight condition, the maximum stress ranges in the web gap in both negative and positive moment regions are of comparable magnitudes as indicated in Table 7 (for example, Locations AK1 and EK2). It should be noted that the connection plate is not welded to the top flange in either the positive or the negative moment regions.

Table 7. Maximum stress range in the tested web gaps due to a single test truck

Location	Web gap configuration (region-girder-diaphragm)	Stress range (ksi)		Reduction (%)
		Tight	Loose	
EX1	Negative-exterior-w/diaphragm	5.80	1.45	75%
BX1	Positive-exterior-w/diaphragm	0.58	-	-
EX2	Negative-exterior-w/diaphragm	2.26	1.16	48%
RX2	Negative-exterior-w/o diaphragm	-	1.02	-
EX3	Negative-exterior-w/diaphragm	4.15	0.93	77%
IX3	Negative-interior-w/diaphragm	2.47	0.35	85%
HX3	Negative-exterior-w/diaphragm, cracks, and drilled holes	4.93	1.63	65%
EK1	Negative-exterior-w/diaphragm-	1.51	0.44	71%
AK1	Negative-exterior-w/diaphragm	2.47	4.35	-76%
HK1	Negative-exterior-w/diaphragm, cracks and holes	0.58	0.44	25%
EK2	Positive-exterior-w/diaphragm	2.64	1.39	47%
IK2	Positive-interior-w/diaphragm	0.93	0.58	38%

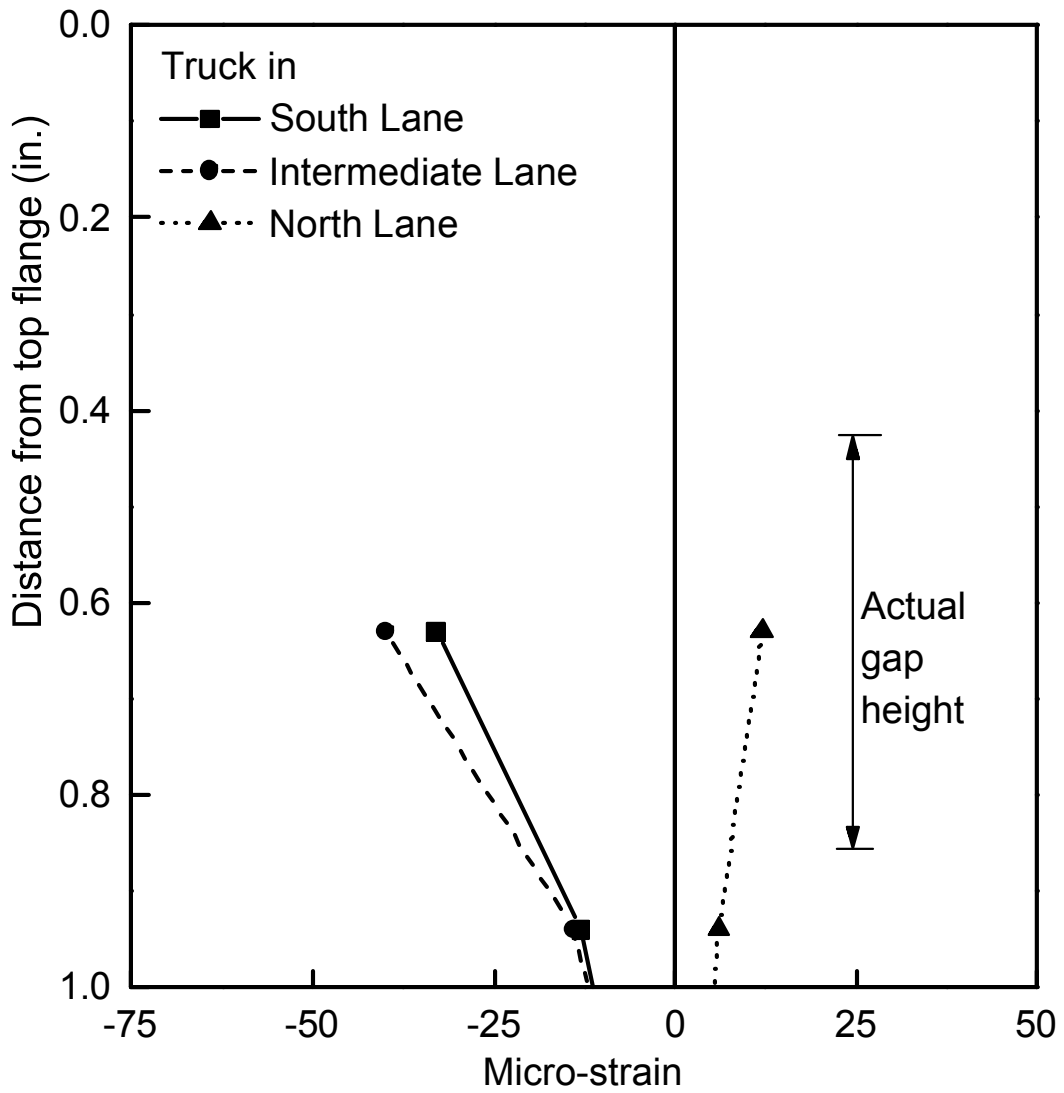

Figure 25. Vertical profile of maximum strains in the web gap at Location EK1 during Tests 1-3 (tight condition tests)

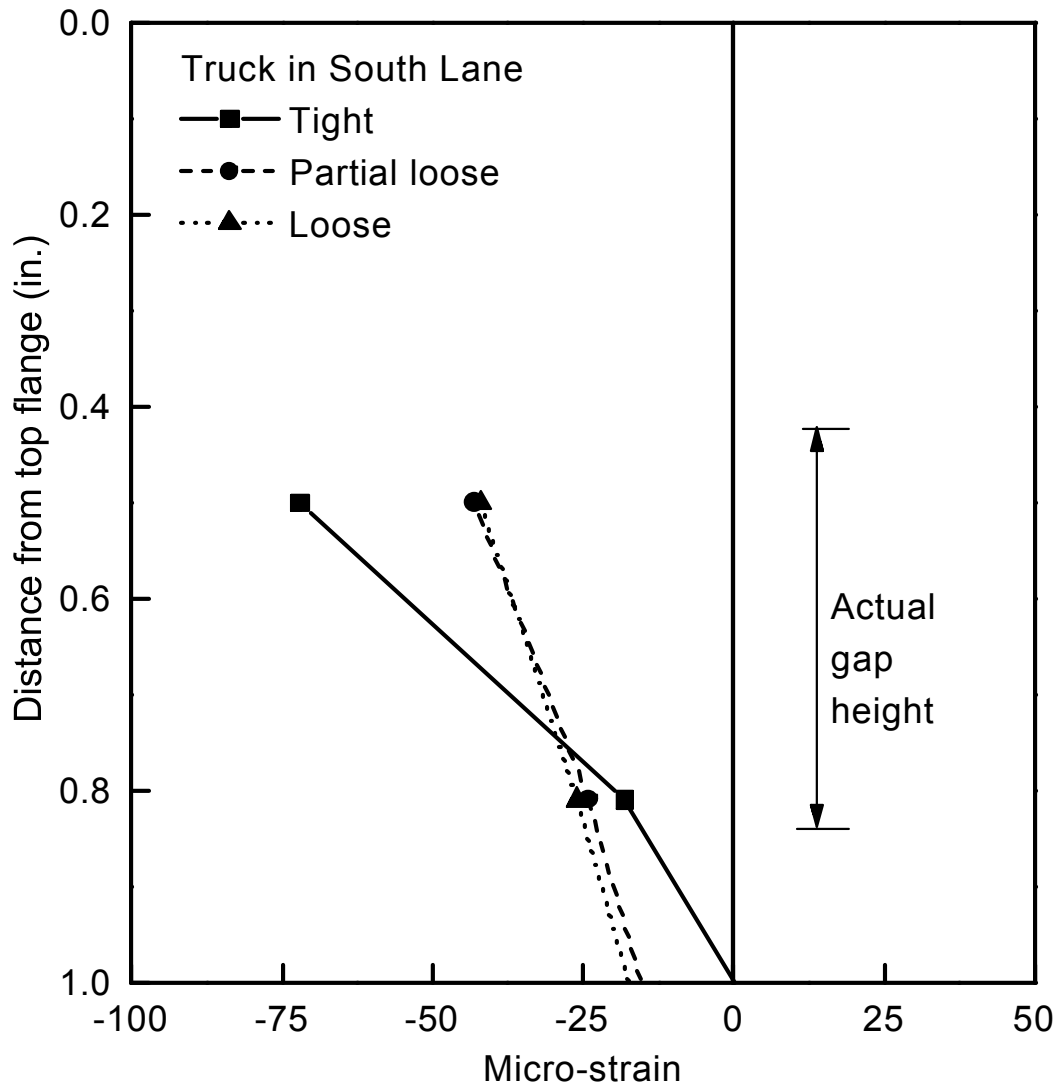

Figure 26. Vertical profile of the maximum strains in the web gap at Location EK2 during Test 1 (tight), Test 4 (partial loose), and Test 7 (loose)

All other gaps showed similar behavior (either in positive or negative moment regions). After loosening the bolts and conducting partial loose or loose tests, strains were significantly reduced in all tested gaps except one (AK1). Figure 26 shows the effect of loosening bolts on the web gap strains at Location EK2 during Tests 1, 4, and 7 (tight, partial loose, and loose, respectively). Similar to the case with X-type diaphragm bridges, partial loose condition produced nearly the same effect as the loose condition or the all bolts loose condition for exterior girder gaps. Although this web gap (EK2) is located in a positive moment region, no different behavior was observed. Interior girders (Location IK2) exhibited a different behavior as illustrated in Figure 27. Strains increased as the exterior panel diaphragm bolts were loosened (partial loose condition). Later, loosening the interior panel bolts reduced the strain levels substantially below those in the tight condition tests. Loosening the exterior panel bolts reduced the forces in the diagonals of that panel. Hence, the net horizontal force acting on the gap at Location IK2 (which is the resultant of the forces in the diagonals of both interior and exterior diaphragm panels) increased. Consequently, the web-gap strains increased. Later, the net force decreased as the interior diaphragm panel was loosened, reducing the web gap strains.

Figure 28 shows the effect of loosening bolts on the web gap of Location AK1. Contrary to the behavior in all other web gaps (either X-type or K-type diaphragm bridges), web gap strains at Location AK1 increased and/or changed sign due to loosening the bolts. One of the three gages installed at that location was damaged during the loosening process and, hence, its readings are not reported for Test 5 (loose condition). During Test 5, the top gage recorded 140 micro-strains (4.06 ksi or 27.97 mPa), a 100% increase over its reading in Test 1 (the corresponding test in the tight condition). Further, the web gap strain distribution at Location AK2 indicates out-of-plane bending even after loosening the bolts. Possible explanations are: (1) flange out-of-plane rotation with the deck slab under the effect of wheel loads, and/or (2) experimental error. However, this increase can not be explained by an increase in the out-of-plane distortion of the web gap (later the out-of-plane displacement is shown for this location). Further experimental and theoretical analyses may be needed to explain why such an increase occurred. The strains at Location HK1 were small

compared to other locations, indicating that the source of cracking was not the out-of-plane distortion.

The reduction percentages in the maximum stress range after loosening bolts are also given in Table 7. The web gap at Location AK1 has a negative reduction. The maximum computed stress range in the tight condition in Bridge K1 was 2.47 ksi (17.02 mPa). After loosening the bolts, this value increased to 4.35 ksi (29.97 mPa). All other web gaps recorded reductions in the stress range upon loosening the bolts, with reduction percentage ranging from 25% to 71%. This is consistent with what was recorded in X-type diaphragm bridges.

Web Gap Out-of-Plane Distortion

X-Type Diaphragm Bridges

As was the case with web gap strains, the out-of-plane displacement showed variation with truck speed and transverse position. Further, out-of-plane displacement and web gap strains were proportional and consistent at every location. Maximum distortion always occurred when the test truck was traveling in the nearest driving lane.

Although web gap size was nearly the same for all the three bridges, the maximum out-of-plane displacement varies from one bridge to another. The maximum out-of-plane displacements were 0.0056, 0.0022, and 0.0042 in. (0.142, 0.056, and 0.107 mm) for EX1 (Bridge X1), EX2 (Bridge X2), and HX3 (Bridge X3), respectively. It should be noted that all maximums occurred at exterior girders.

The maximum out-of-plane displacements at interior girders of non-skew bridges were significantly less than those at exterior girders. For example, the maximum out-of-plane displacement at Location IX1 was 0.0011 in. (0.028 mm) compared to 0.0056 in. (0.142 mm) at Location EX1. For skew bridges, however, the out-of-plane displacements were of comparable magnitudes at interior and exterior girders. The maximum out-of-plane displacements at Location RX2 (with no diaphragm connection) and at Location BX1 (web gap near the bottom flange), with values of 0.0002 in. (0.005 mm) and 0.0003 in. (0.008 mm), respectively, were considerably less than those at any other web gap.

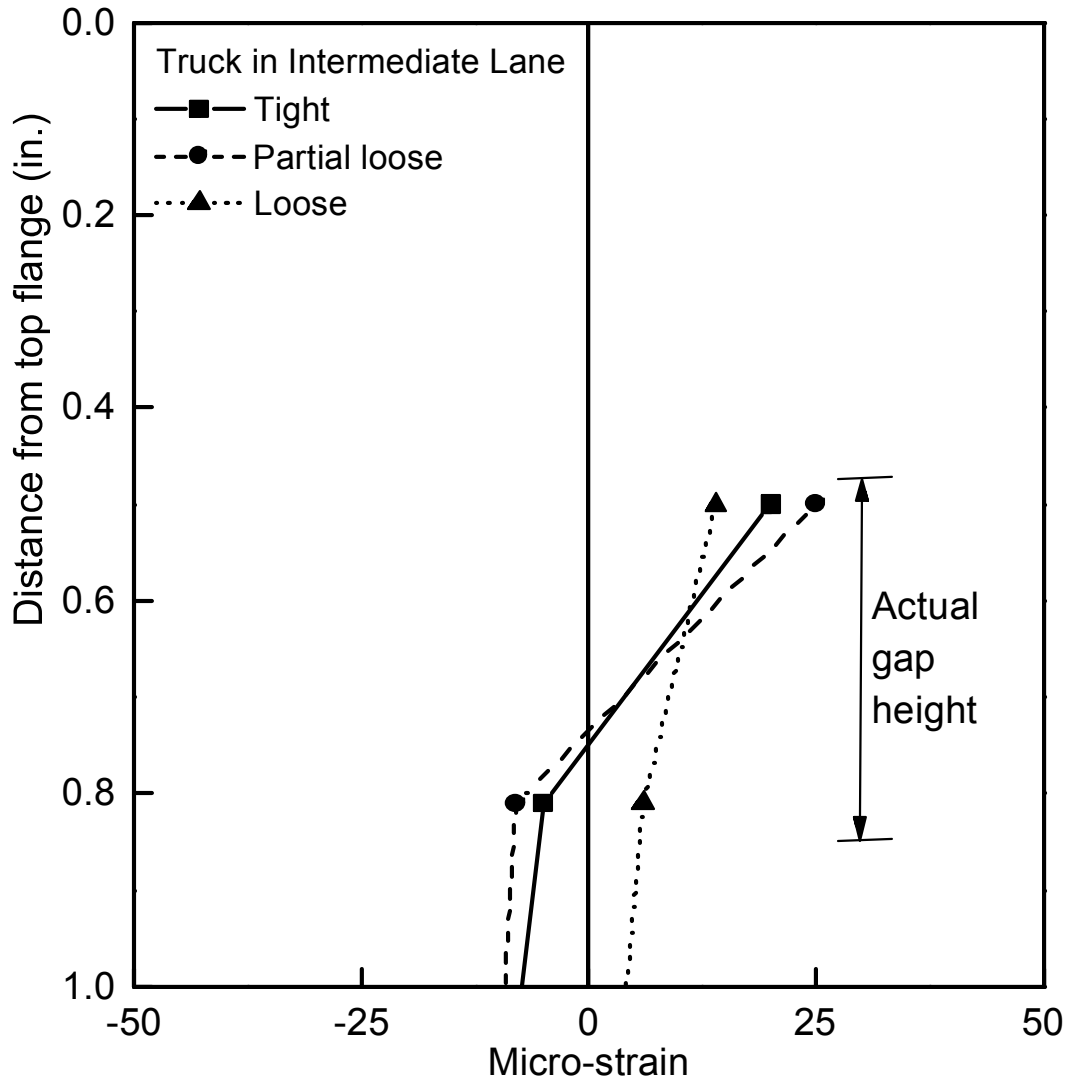

Figure 27. Vertical profile of the maximum strains in the web gap at Location IK2 during Test 2 (tight), Test 5 (partial loose), and Test 8 (loose)

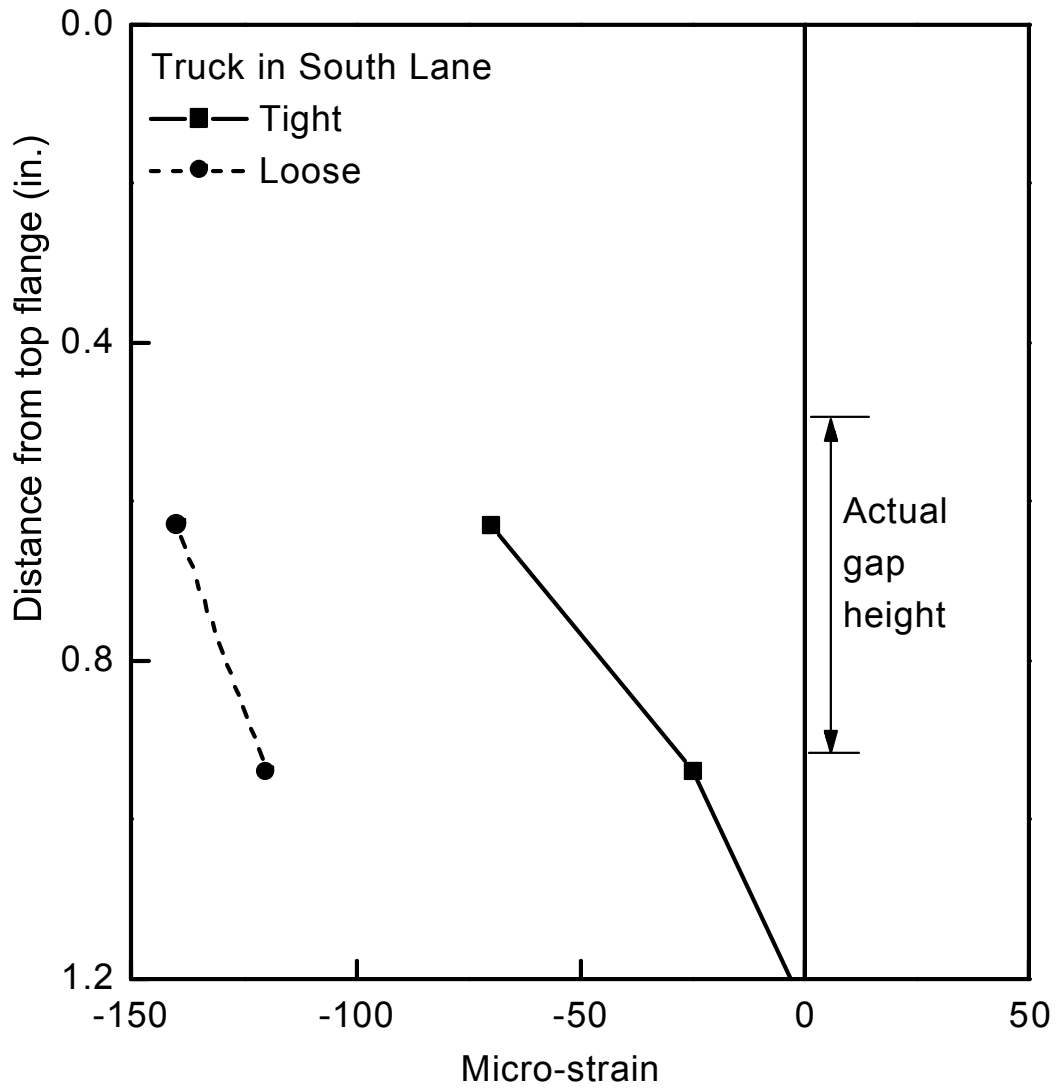

Figure 28. Vertical profile of the maximum strains in the web gap at Location AK1 during Test 1 (tight), and Test 5 (loose)

Table 8. Maximum out-of-plane distortion of the tested web gaps due to a single test truck

Location	Web gap configuration (region-girder-diaphragm)	Out-of-plane distortion (in.)		Reduction (%)
		Tight	Loose	
EX1	Negative-exterior-w/diaphragm-	0.0056	0.0015	73%
IX1	Negative-interior-w/diaphragm	0.0011	0.0008	27%
BX1	Positive-exterior-w/diaphragm	0.0003	-	-
EX2	Negative-exterior-w/diaphragm	0.0022	0.0012	45%
RX2	Negative-exterior-w/o diaphragm	-	0.0002	-
EX3	Negative-exterior-w/diaphragm	0.0018	0.0003	83%
IX3	Negative-interior-w/diaphragm	0.0017	0.0002	88%
HX3	Negative-exterior-w/diaphragm, cracks and drilled holes	0.0042	0.0006	86%
EK1	Negative-exterior-w/diaphragm-	0.00030	0.00015	50%
AK1	Negative-exterior-w/diaphragm	0.00040	0.00032	20%
HK1	Negative-exterior-w/diaphragm, cracks and holes	0.00040	0.00025	38%
IK1	Positive-interior-w/diaphragm	0.00055	0.00020	64%
EK2	Positive-exterior-w/diaphragm	0.00050	0.00015	70%
IK2	Positive-interior-w/diaphragm	0.00015	0.00010	33%

The out-of-plane displacement at Location HX3 (with cracks and drilled holes) was more than twice that of Location EX3 (in the same bridge). This implies that the presence of cracks and drilled holes reduced the lateral stiffness of the web gap significantly. It should be noted, however, that the maximum strain values were of corresponding magnitudes at the two locations. After applying the proposed method, the distortion was reduced significantly. That of Location EX1, for example, was reduced to 0.0015 in. (0.038 mm), a reduction of 73%. Reduction percentages of out-of-plane distortion at exterior girders ranged from 42% to 86%. At interior girders, where the out-of-plane distortion was generally smaller, it ranged from 27% to 88%. Table 8 summarizes the maximum out-of-plane distortion at each of these locations due to a single truck passage. In Bridge X2, the out-of-plane distortion at Location EX2 is larger than (up to 10 times greater) that at Location RX2 (with no diaphragm connection) even after loosening the bolts. A possible explanation is that after loosening the bolts, the diaphragm diagonals bore against the loosened bolts leading to the development of forces which contributed to the out-of-plane distortion.

Figure 29 shows the effect of the proposed method on the maximum out-of-plane displacement of the instrumented locations (EX3, IX3, and HX3) in Bridge X3. Generally, loosening only the exterior diaphragm panel lower bolts (partial loose condition) produced effects comparable to complete loosening both exterior and interior panel lower bolts (loose condition) on the web gap at of exterior girders. For interior girders, there was a significant reduction in the out-of-plane distortion between the partial loose and loose condition tests. Further loosening of the upper bolts of the exterior panel did not improve the behavior of the web gaps.

K-Type Diaphragm Bridges

With the bolts tight, the maximum out-of-plane displacement was 0.00055 in. (0.014 mm) at Location IK1. It should not be surprising that the maximum distortion occurred at an interior girder (not an exterior one), as diaphragms are discontinuous in Bridge K1 leaving exterior and interior girders with equal opportunities of distortion. Maximum out-of-plane distortion at other locations ranged from 0.00020 to 0.00040 in. (0.005 to 0.010 mm). As can be noted, the out-of-plane displacements in the tested K-type diaphragm bridges are substantially less than those in X-type diaphragm bridges. One or more of the following factors may have contributed: (1) web gaps

were smaller which affected their out-of-plane stiffness, (2) a horizontal top member exists in the K-type diaphragm which may have reduced the horizontal force transmitted through the web gap area, (3) K-type diaphragms behave differently than X-type diaphragms. The maximum out-of-plane displacement at Location HK1 was 0.00040 in. (0.010 mm), a value smaller than that of the out-of-plane displacement at Location EK1 without cracks. If the crack at Location HK1 was the result of out-of-plane web distortion, similar cracks should have appeared at Location EK1. This implies such a crack (crown crack) could be attributed to the out-of-plane distortion (note that the strains gave a similar indication).

Listed in Table 8 are the maximum out-of-plane displacements in the tight and loose condition tests along with the reduction percentages. After loosening the bolts, the out-of-plane displacement was reduced at all locations including Location AK1, in which the stress range increased after loosening the bolts (see previous section). That eliminates the possibilities that the stress increase at the same location was caused by an increased out-of-plane distortion. Reduction percentages ranged from 20% at Location AK1 to 70% at Location EK2. Figure 30 shows the effect of the proposed method on the maximum out-of-plane displacement measured in Bridge X3. As with X-type diaphragm bridges, the partial loose condition resulted in an increase in the distortion of interior girder (Location IK2). The loose condition, however, lowered the distortion to levels significantly below that in the tight condition. For exterior girders, slight reductions occurred going from partial loose to loose and from loose to all bolts loose.

Web Gap Relative Vertical Displacement

At Location IX1, two transducers were attached to the connection plates on either side of the web plate with their stems bearing against the top flanges. The purpose was to measure the relative vertical displacement between the top flange and the stiffener plates. Possible causes for relative vertical displacement between the top flange and the web plate include: (1) out-of-plane rotation of the top flange (rotation of the top flange about an axis parallel to the longitudinal centerline of the bridge), while being rigidly attached to the deck slab, and (2) extension or compression of the web gap. The readings of the two transducers were used to compute the flange rotation and the web extension. The computed values during crawl speed-single truck tests are

plotted in Figure 31. Clearly, the change in web gap extension was very small. Web gap extension or compression is mainly caused by the vertical loads transmitted from the deck to the girder, implying that there was a very slight change in the transmitted load upon loosening the bolts. This means that the effect of loosening the bolts on the lateral load distribution is minimal. On the other hand, the change in flange rotation was relatively large, implying that the deck slab role in laterally distributing the loads increased.

Diaphragm Diagonal Forces (X-Type and X-Type Diaphragm Bridges)

Table 9 lists the maximum forces computed in diaphragm diagonals for both X-type and X-type diaphragm bridges. Forces were measured in four diagonals connected near the top flange of exterior girders with maximum tensile forces ranging from 1.13 kips (5.10 kN, in Bridge X3) to 1.47 kips (6.60 kN, in Bridge K2). Forces in only one diagonal connected near the bottom flange of the exterior girder at Location EX1 were computed with a maximum compressive value of (-1.65) kips (-7.41 kN). Clearly, X-type and K-type diaphragm diagonal forces were of comparable magnitude in the tight condition.

Plotted in Figure 32 are the web gap out-of-plane displacement, the strains recorded using the top gage in the gap area, and the force in the diagonal connected near the top flange at Location EX2 during Tests 1-4 (tight condition). A direct correlation is apparent between both the strains in the web gap region and the web gap out-of-plane distortion and the forces in the diaphragm diagonal. Likewise, although not shown here, similar relations were obtained for the other bridges.

There was an expected substantial decrease (73% to 95%) in the forces after loosening the bolts. However, the forces did not vanish completely, implying that some forces develop in the diaphragms even in the loose conditions. Forces in the loose condition in K-type diaphragm bridges were greater than those in the X-type diaphragm bridges. In other words, the reduction in force in K-type diaphragm bridges (73% to 86%) is less than that in X-type diaphragm diagonals (89% to 95%). The presence of the top horizontal member in the K-type diaphragms may have introduced a closed frame action and, consequently, some forces developed in the diagonals even after loosening the top connection bolts.

Global Effect of the Method

Lateral Distribution of Loads

The effect of the proposed retrofit method on the lateral live load distribution was investigated in Bridges X2 and K2. Figure 33 shows the maximum exterior girder bottom flange strains during crawl speed tests (Tests 1-4 and Tests 10-13). Apparently, there is a slight change in the strains after applying the proposed method. The investigation showed that loosening the diaphragm diagonal connection bolts had a small effect (within 12% and 15% for Bridge X2 and K2, respectively) on the distribution.

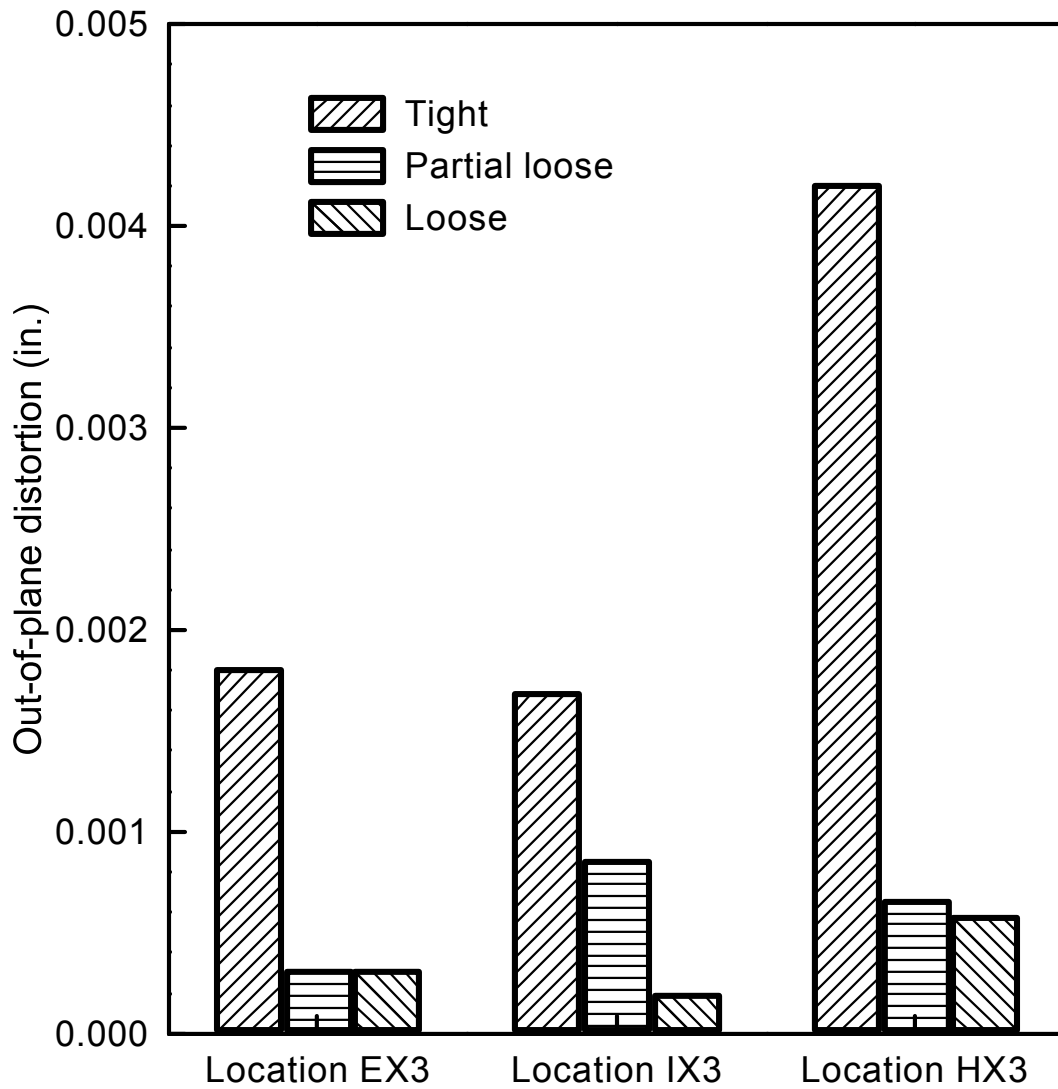

Figure 29. Maximum out-of-plane displacements of Locations EX3, IX3, and HX3 during tight, partial loose, and loose tests

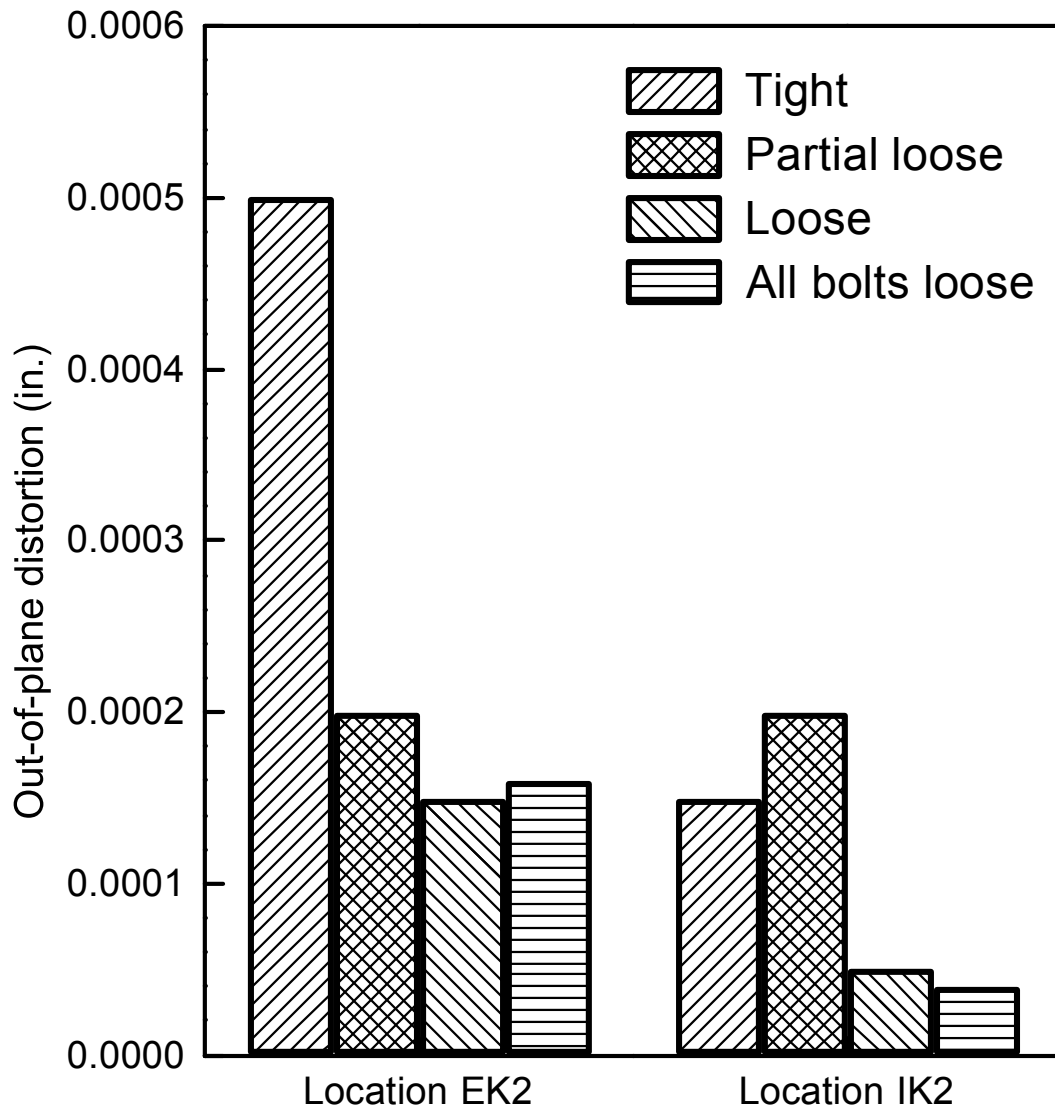

Figure 30. Maximum out-of-plane displacements of Locations EK2 and IK2 during tight, partial loose, loose, and all bolts loose tests

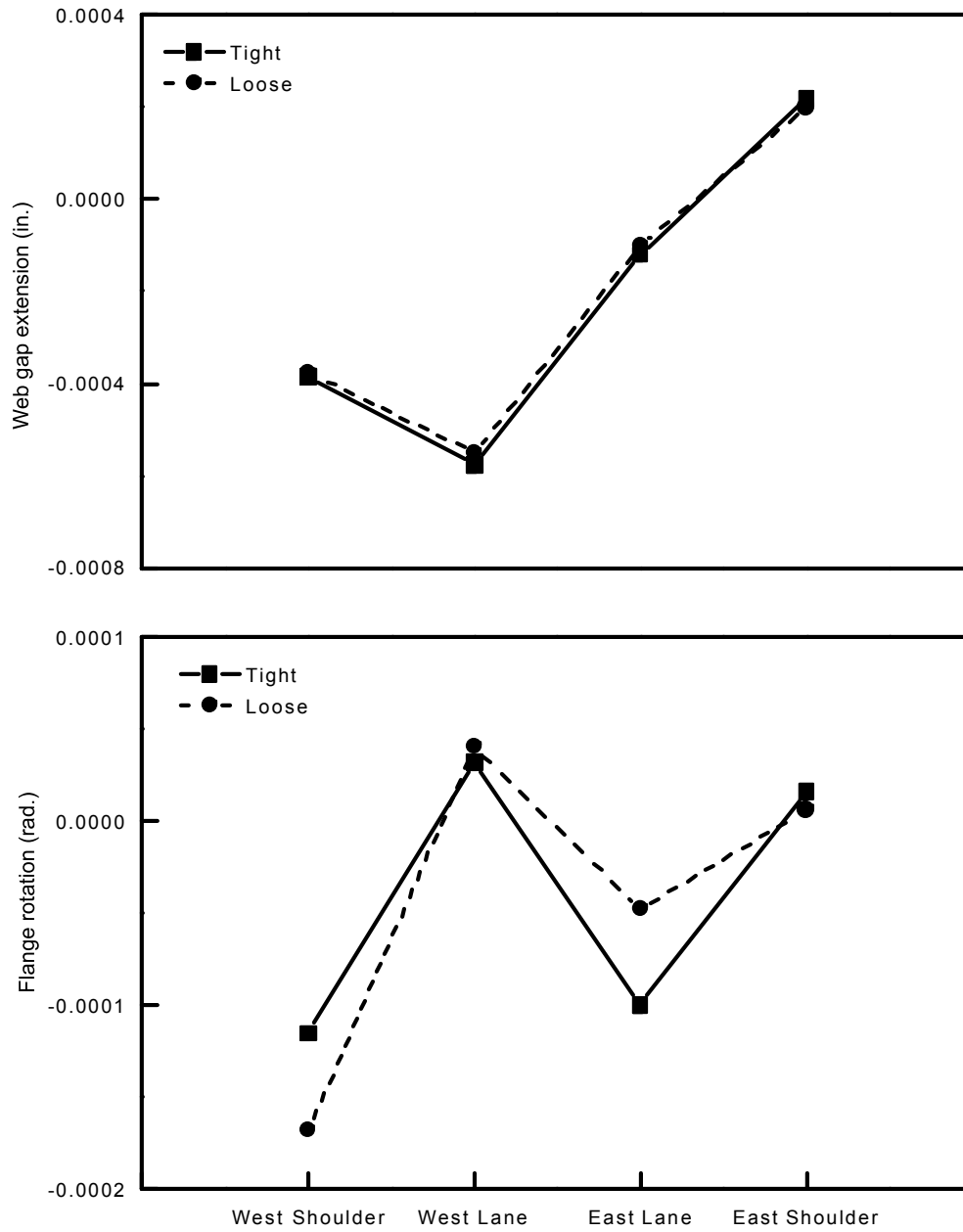

Figure 31. Web extension and flange out-of-plane rotation at Location IX1 during Tests 1-4 and 10-13

Table 9. Maximum force in the diaphragm diagonals due to a single test truck

Location	Location of diagonal w.r.t. exterior girder	Force (kips)		Reduction (%)
		Tight	Loose	
EX1	Connected near the top flange	1.40	0.07	95%
EX1	Connected near the bottom flange	-1.65	-0.11	93%
EX2	Connected near the top flange	1.33	-	-
EX3	Connected near the top flange	1.13	0.12	89%
EK1	Connected near the top flange	1.39	0.37	73%
EK2	Connected near the top flange	1.47	0.20	86%

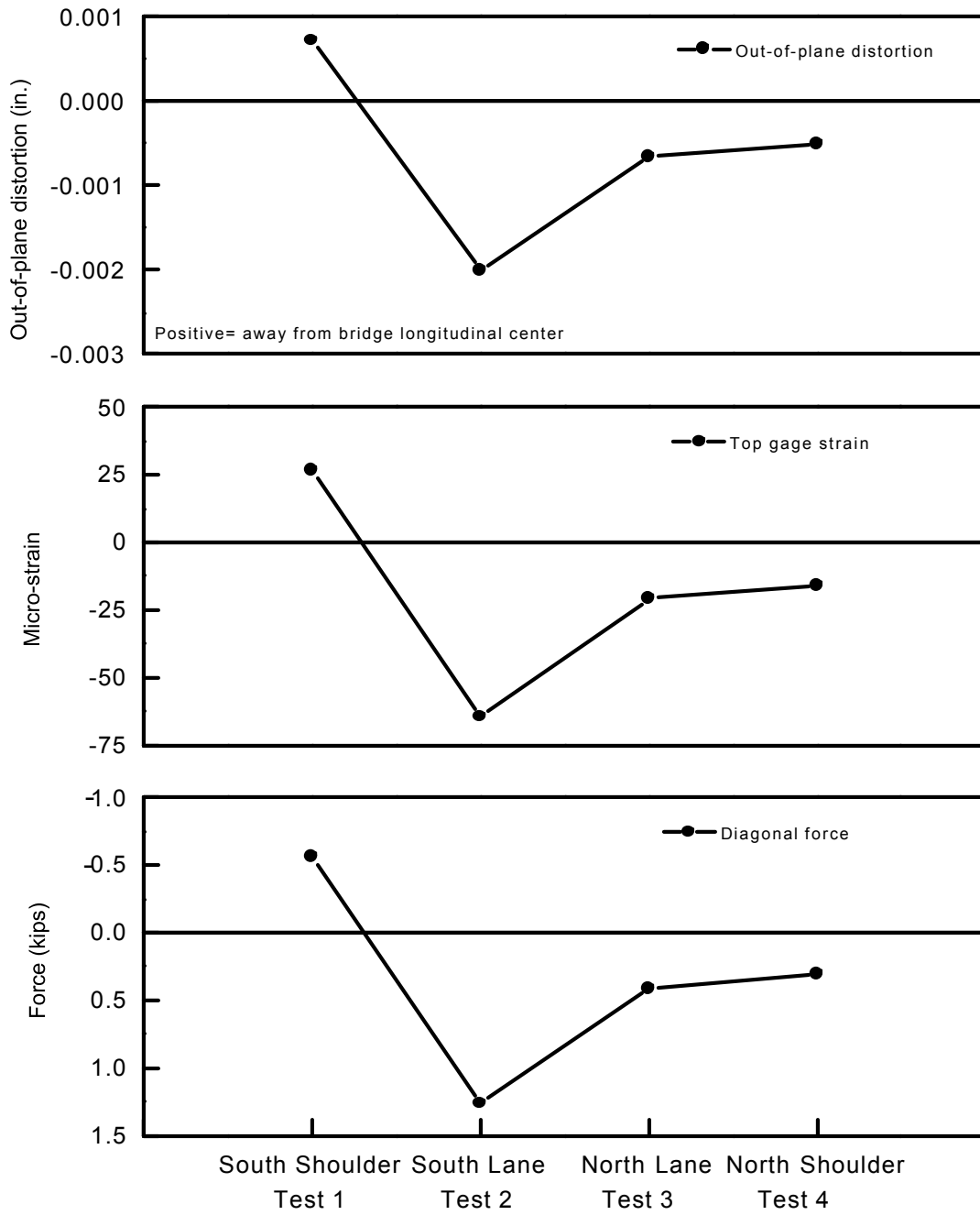

Figure 32. Out-of-plane distortion, top gage strain, and diaphragm diagonal force at Location EX2 during Tests 1-4

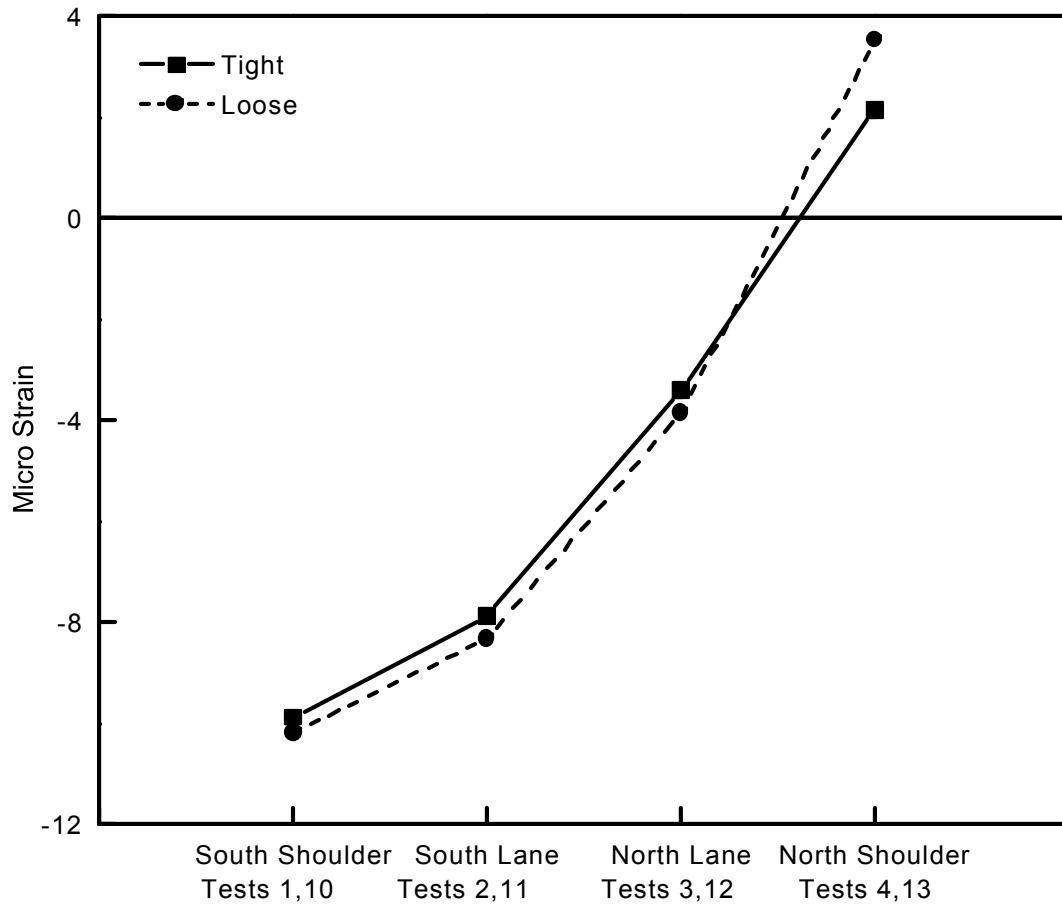

Figure 33. Maximum exterior girder bottom flange strains in Bridge X2 during tight and loose condition tests

ASSESSMENT OF THE PROPOSED METHOD

Experimental Evaluation

The experimental results of this study have shown that the proposed method (loosening diaphragm bolts in the negative moment region) can be effective as a retrofit technique to prevent cracking resulting from out-of-plane distortion of web gaps in X-type diaphragm bridges. Loosening the exterior diaphragm panel bolts would be sufficient if only exterior girders are concerned. However, loosening both exterior and interior diaphragms is recommended to eliminate similar problems at interior girders.

For K-type diaphragm bridges, the increase in the stress range at the exceptional web gap reduces the confidence for implementing the retrofit method in K-type diaphragm bridges. There is a need to further investigate the proposed method in other K-type diaphragm bridges with different web gap sizes and diaphragm configuration (diaphragms without top chord). Few bridge in Iowa have K-type diaphragms.

Other Design Aspects

Starting in the late 1940s, AASHTO required diaphragms or cross frames in steel multi-girder bridges. An arbitrary requirement of diaphragms spaced at not more than 25 ft (7.6 m) in the 15th Edition of the AASHTO Specification [12] has been replaced in the First Edition of AASHTO LRFD [4] by the following paragraph to reduce fatigue-prone details:

Diaphragms or cross frames may be placed at the end of the structure, across interior supports, and intermittently along spans. The need for diaphragms or cross frames shall be investigated for all stages of assumed construction procedures and the final condition.

AASHTO [4] identified some functions of diaphragms and cross frames which include: (1) transferring lateral wind load from the bottom of girders to the deck slab and from the deck slab to the support system, (2) providing stability of the top compression flange in positive moment regions during construction or deck replacement, (3) providing stability of the bottom compression flange under various types of loads, and (4) distributing vertical loads among girders. Cross frames and

diaphragms may serve other functions such as providing transverse integrity in cases of extreme events, such as a bridge being hit by a passing vehicle or vessel. All these functions should be considered before deciding to implement the proposed retrofit method. In curved bridges, however, diaphragms serve other functions which are outside the scope of the current study. Hence, the proposed method can not be implemented in curved bridges without detailed investigations.

Stallings et al. [13] studied the effect of diaphragm removal from steel bridges. Their results showed that bottom flange stresses due to wind loading are not likely to govern in normal span lengths (within 200 ft or 61 m). However, they recommended that calculations should be performed for any bridge for which the proposed method is planned.

Considering the stability issue (3 above), calculations were performed for all the tested bridges to ensure that the distance between the bracing at the pier and the first diaphragm in the positive moment region was less than allowed by Equation 6.10.5.3.3d-1 of the AASHTO [4]. This equation should always be checked before the proposed method is implemented. During replacement of the deck slab, the same check must be made but with the following exception, r_t = minimum radius of gyration of the compression flange about the vertical axis (see AASHTO [4] Article 6.10.6.3.1).

In an experimental investigation, Stallings et al. [13] measured girder strains and deflections before and after diaphragm removal. They showed that an increase of approximately 15% could be expected in girder longitudinal stresses if diaphragms are removed completely. However, they commented that the increased girder stresses did not exceed those computed using the AASHTO Specifications [12]. Consequently, they judged the diaphragm removal to be insignificant. It should be mentioned that the effect of loosening bolts of the diaphragm panels in the negative moment region is expected to be significantly less than the effect of removing all the diaphragms.

During extreme events such as earthquakes, floods, and collision by vessels or vehicles, it is expected that large deformation would occur in the bridge and, hence, the diaphragm with loose bolts would contribute to resisting the associated loads.

Based on the discussed design aspects, the following design steps should be performed before implementing the method: (1) check the Strength III and Strength V limit states, specifically, the bottom flange stresses in the negative moment region, and (2) check that the lateral unsupported length of the compression flange is less than the maximum specified by AASHTO [4].

SUMMARY, CONCLUSIONS AND RECOMMENDATIONS

Summary

The Iowa Department of Transportation (Iowa DOT) has proposed a method to prevent web cracking at diaphragm/plate girder connections in steel bridges. The method consists of loosening the bolts that connect the diaphragm diagonals to the girder webs.

Five bridges were tested: three with X-type diaphragms and two with K-type diaphragms. The local and global bridge responses were measured at various locations. The following points represent the summary of the experimental testing:

1. Web gaps at exterior girders suffered the greatest out-of-plane distortion. The distortion levels at interior girders of non-skew bridges were significantly less than those at exterior girders. For skew bridges, however, interior girder distortions were only slightly less than exterior girder distortions.
2. The out-of-plane distortion ranges up to 0.0056 in. (0.142 mm) for X-type diaphragm bridges and up to 0.00055 in. (0.014 mm) for K-type diaphragm bridges. The maximum out-of-plane distortion in K-type diaphragm bridges was approximately 10% of that in X-type diaphragm bridges, probably because of the very small gap size in the case of K-type diaphragm bridges and geometrical diaphragm configuration (K-type diaphragms had horizontal upper chord near the top flange).
3. Drilling holes at the crack tips increases the flexibility of the web gap and, consequently, increases the out-of-plane distortion. Further, the stress range in web gaps with cracks and drilled holes is not significantly influenced if the holes are close to the connection plates.
4. Other factors contribute relatively small effects to web gap stresses including: (1) the out-of-plane flange rotation with the deck slab, and (2) the web gap extension or compression due to direct load transfer from the deck slab to the girders.

The following are the effects of applying the proposed method:

1. Implementing the method resulted in a substantial reduction in the diaphragm diagonal forces, which are the main reason for the out-of-plane distortion. Consequently, this resulted in considerable reductions in the out-of-plane distortion and the web gap strains.
2. Except for one web gap in a K-type diaphragm bridge, the maximum stress ranges were reduced by at least 25% due to implementing the method. This would result in extending the fatigue life of the web gap details by a considerable period, as the fatigue life is approximately inversely proportional to the cubic power of the maximum stress range.
3. The proposed method has a very slight effect on the lateral distribution of vertical loads. Its effect was estimated to be within 10 to 15% for both skew and non-skew bridges.
4. Loosening the exterior diaphragm panel bolts enhanced the behavior of the exterior girder web gaps; however, it could affect the interior girder web gaps adversely (as some of the interior-girder web gap stresses increased when the bolts of exterior diaphragm panels were loosened). The largest improvement in the web gap behavior of both the exterior and interior girders was achieved by loosening the bolts of the exterior as well as the interior diaphragm panels (in this case, both exterior and interior girder web gaps recorded stress reductions).
5. There was a wide variance in the percentage change in both the out-of-plane distortion and the stress range due to implementing the proposed retrofit method. This is probably because of the unique nature of each web gap.

Conclusions

The following conclusions are based on the field testing of five bridges with a limited number of variables (web gap height, number of girders in the cross section of the bridge, slab thickness, etc.). Extending these conclusions for other cases may be invalid. Further, these conclusions can not be applied to curved bridges.

1. The proposed retrofit method (loosening the bolts of all diaphragm panels in the negative moment region) can be adopted for steel bridges with X-type diaphragms after conducting the design checks.

2. Further experimental and theoretical investigations are required before the proposed method can be implemented in K-type diaphragm bridges.

Recommended Further Research

1. A bridge with X-type diaphragms should be retrofitted with the proposed method and long term monitoring should be performed for that bridge.
2. Further investigation is needed for K-type diaphragm bridges to study different aspects of behavior, such as the effect of closed frame action and the web gap height.
3. Web gap behavior is affected by various factors (such as gap height, diaphragm type, slab thickness, composite action, etc.). Further study on how these factors affect the behavior of web gaps is recommended.
4. Loosening the diaphragm bolts may increase the share of the deck slab in lateral distribution of live load. This might have effects on the performance of the deck slab; therefore, the long-term effects on the service life of the deck slabs should be studied.

ACKNOWLEDGMENT

The authors would like to acknowledge the efforts of numerous Iowa Department of Transportation personnel who helped with the field testing. In particular, the authors are appreciative of the comments and technical input by Bruce Brakke, Director of office of Bridge Maintenance. Other personnel within the maintenance division are also thanked for their assistance.

REFERENCES

1. J.W. Fisher, *Fatigue Cracking of Steel Structures: Volume III*, US Department of Transportation, Publication No. FHWA-RD-89-168, Washington, D.C.: Federal Highway Administration, 1990.
2. J.W. Fisher, *Fatigue and Fracture in Steel Bridges: Case Studies*, New York: John Wiley & Sons, 1984.
3. Fisher, J.W.; and B.T. Yen, "Distortion Induced Fatigue Cracking in Steel Box Bridges", *Proceeding of The Third International Workshop on Bridge Rehabilitation*, pp. 627-636, Darmstadt, Germany: University Of Darmstadt, 1992.
4. American Association of State Highway and Transportation Officials, *AASHTO LRFD Bridge Design Specifications, Customary U.S. Units, First Edition*, Washington, D.C.: American Association of State Highway and Transportation Officials, 1994.
5. Fisher, J.W.; and P.B. Keating, "Distortion-Induced Fatigue Cracking of Bridge Details with Web Gaps", *Journal of Constructional Steel Research*, , Vol. 12, pp. 215-228, New York: ASCE 1989.
6. Fisher, J.W.; Jin, J.; Wagner, D.C.; and B.T. Yen, *Distortion Induced Fatigue Cracking in Steel Bridges*, NCHRP Report 336, TRB, National Research Council, 1990.
7. Fisher, J. W.; Yen, B.T.; and D.C. Wagner, "Review of Field Measurements for Distortion Induced Fatigue Cracking in Steel Bridges", *Transportation Research Record*, No.1118, pp. 49-55, Washington, D.C.: TRB, National Research Council, 1987.
8. P.B. Keating, "Focusing on Fatigue", *Civil Engineering*, Vol. 64, No. 11, pp. 54-57, New York: ASCE, 1994.
9. Stalling, J. M.; and T.E. Cousins, "Evaluation of Diaphragm Requirements in Existing Bridges", *Proceeding of the ASCE structural Congress XV*, pp. 1494-98, New York: ASCE, 1997.

- 10 Cousins, T.E.; Stallings, J.M.; Lower, D.A.; and T.E. Stafford, "Field Evaluation of Fatigue Cracking in Diaphragm-Girder Connections", *Journal of Performance of Constructed Facilities*, Vol. 12, No. 1, pp. 25-32, New York: ASCE, 1998.
11. S.J. Maddox, *Fatigue Strength of Welded Structures, Second Edition*, Cambridge, England: Abington Publishing, 1991.
12. American Association of State Highway and Transportation Officials, *Standard Specifications for Highway Bridges, Fifteen Edition*, Washington, D.C.: American Association of State Highway and Transportation Officials, 1992.
13. Stallings, J.M.; Cousins, T.E.; and T.E. Stafford, "Effect of Removing Diaphragms from Steel Girder Bridge", *Transportation Research Record 1541*, pp. 183-188, Washington, D.C.: TRB, National Research Council, 1996.