

# The Europa Lander Mission: A Space Exploration Challenge for Autonomous Operations

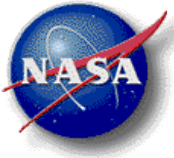

# Talk Outline

- Introduction
- Europa and Icy Worlds
- Europa Lander
- Autonomy Challenges
  - Proposed mission
  - Future mission

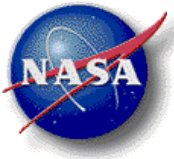

# Europa and Icy Worlds

- What are the Icy Worlds?
  - Jupiter's moons: Europa, Ganymede, Callisto
  - Saturn's moons: Titan, Enceladus
- What is known about them so far?
  - Many have liquid water oceans (first inferred from indirect measurements e.g. mass & magnetic fields, then from plumes.)
  - Recent discovery of plumes (Enceladus, Europa) indicates water vapor from interior being expelled at surface
- Other bodies of interest exhibit plume behavior
  - Comets (67P Churyumov-Gerasimenko)

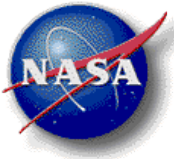

# Europa and Icy Worlds

Europa plumes from Galileo data 1997.  
Composite of Galileo, Hubble, Voyager data.  
Nature Astronomy 2018

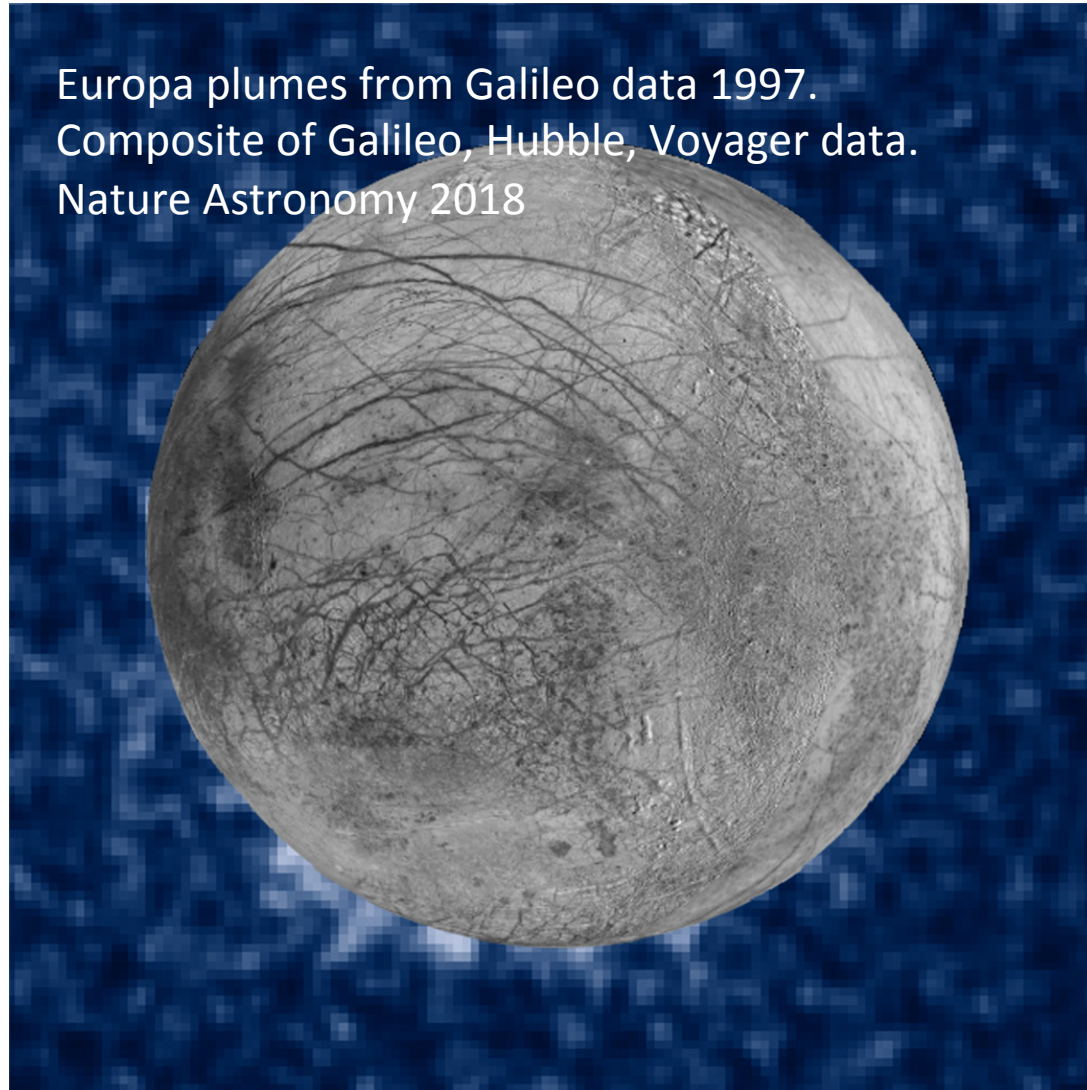





# Europa and Icy Worlds

Enceladus plumes. Cassini, 2010

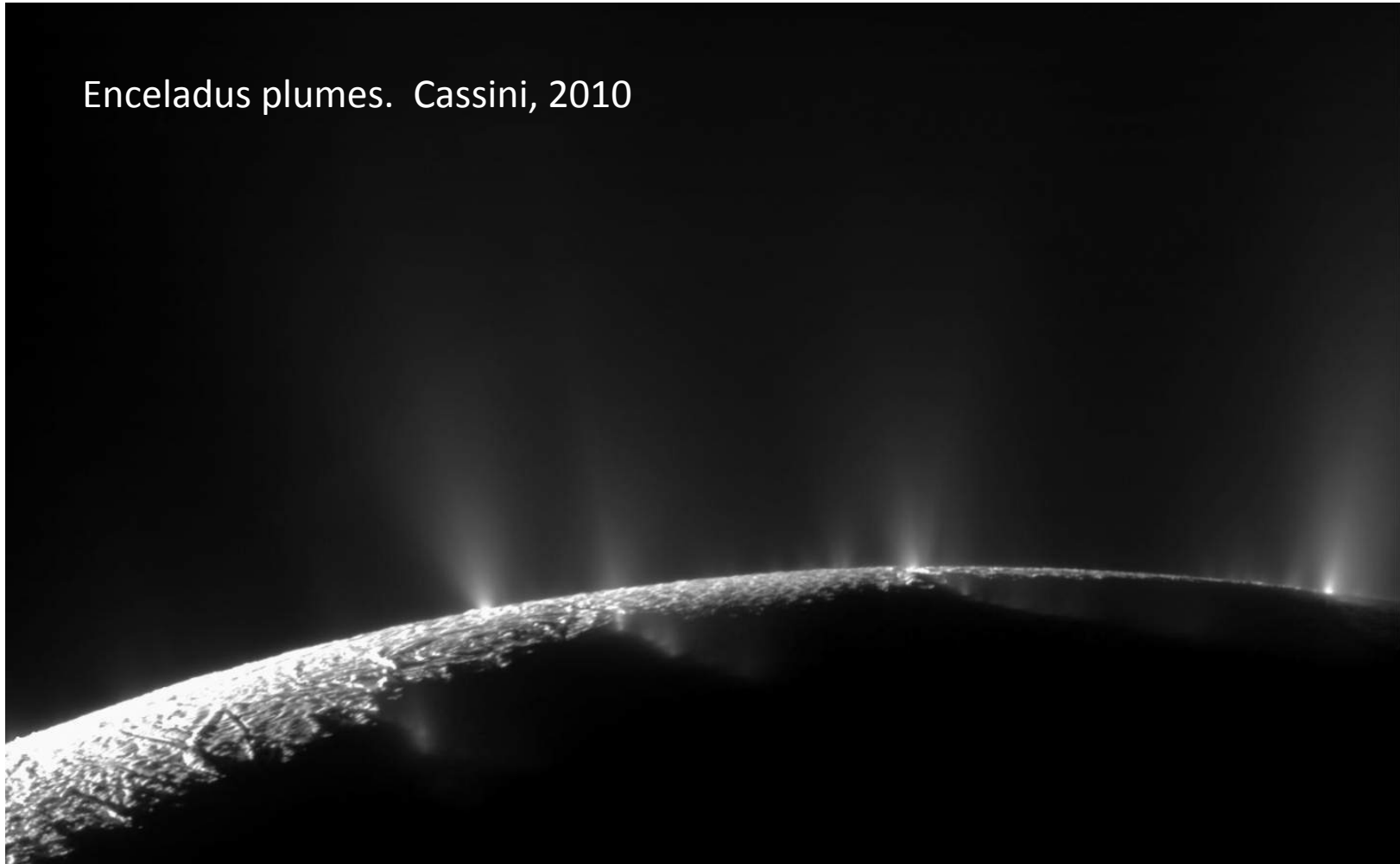

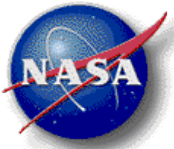

# Europa and Icy Worlds

67P Churyumov-Gerasimenko plumes.  
Rosetta, 2015

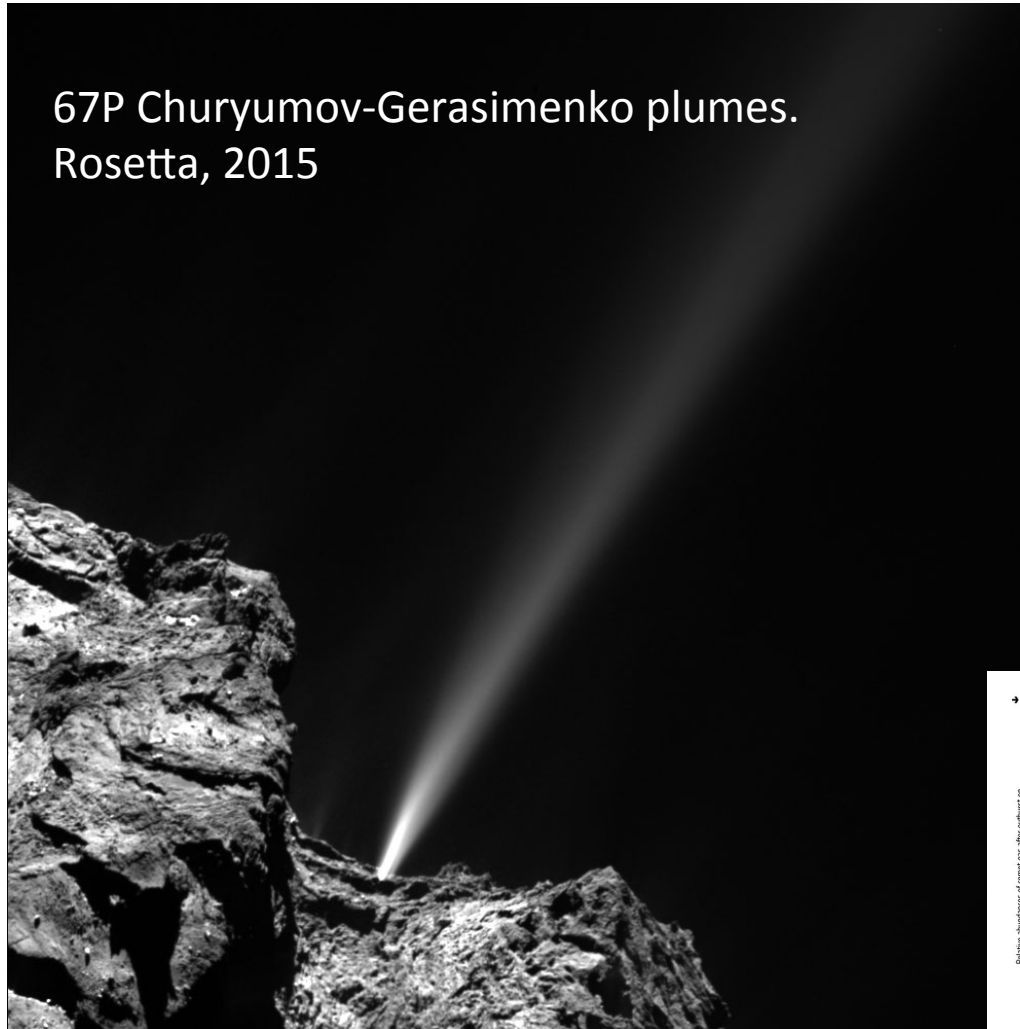

→ ROSINA MEASUREMENTS OF COMET GAS FOLLOWING OUTBURST

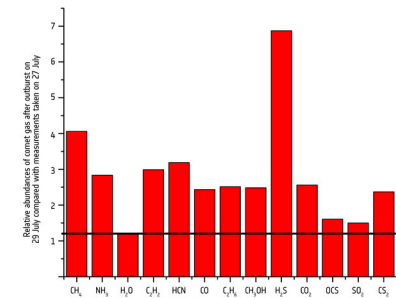

Likely not water but organics present!

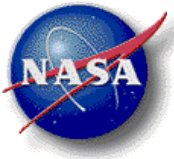

# Europa and Icy Worlds

- Why are Icy Worlds exciting?
  - Water is considered a precondition for life.
  - Prior Europa missions envisioned drilling...but...
    - Europa's crust estimated 25 km thick!
  - Existence of plumes indicates water may be accessible at the surface without need for drilling!
  - Discovery of life off of Earth would be *the scientific discovery of our lifetimes!*



# Europa and Icy Worlds



APOD, April 1, 2016



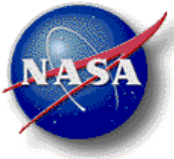

# Europa Lander Mission

- Mission as proposed
  - Science Objectives
  - Mission design
  - Lander design
  - Operational constraints
  - Concept of Operations
- Motivates autonomy needs
  - For mission as proposed
  - More aggressive autonomy for future missions

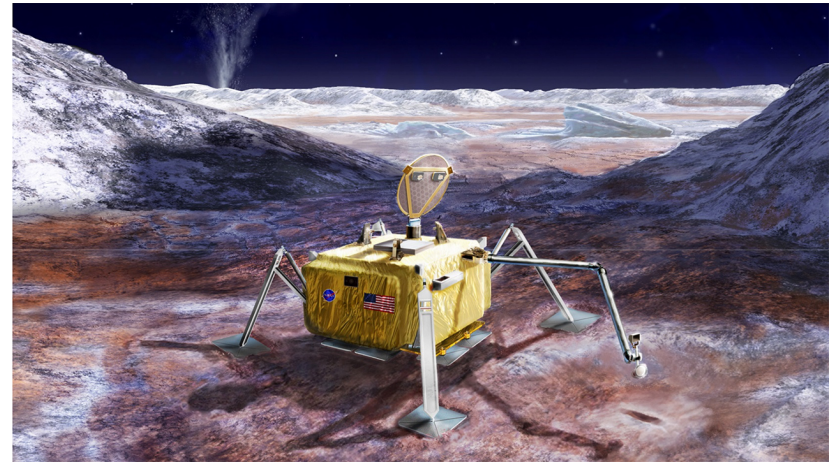

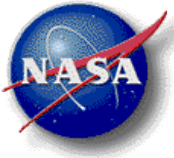

# Europa Lander Mission

- Science Objectives
  - Search for evidence of life on Europa
    - Organic & inorganic indicators
  - Assess habitability of Europa
    - Is there liquid water at the surface?
    - Chemical (non-ice) composition
  - Characterize surface and subsurface properties to support future exploration
    - Surface properties
    - Dynamic properties (i.e. a plume!)

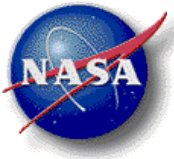

# Europa Lander Mission

- The Europa lander mission is primarily a life detection mission. Signs of life include (but are not limited to)
  - Patterns in occurrence of organic molecules associated with biological processes.
  - Specific targets include carboxylic acids, amino acids, lipids, and some other byproducts such as methane.
- Determining environment is important
  - Ice, Salts, Silicates, metal hydroxides, and other materials.
  - Determines context of life vs habitability vs inhabitability
  - Radiation induced processes change chemistry and physics of surface
- Determination of where the sampled material originated is important
  - Just because it came from the surface doesn't mean the sample originated there!
  - Sub-surface or impact from Jovian system



# Europa Lander Mission

- Measurement of these signs requires (among other techniques) purification, separation, chromatography, mass-spectrometry, micron-to macro- scale imaging, IR and Raman spectroscopy, etc.
  - On very cold samples.
  - In a high-rad environment.
  - On a strict power budget!
  - IN 20 DAYS!
  - Really.

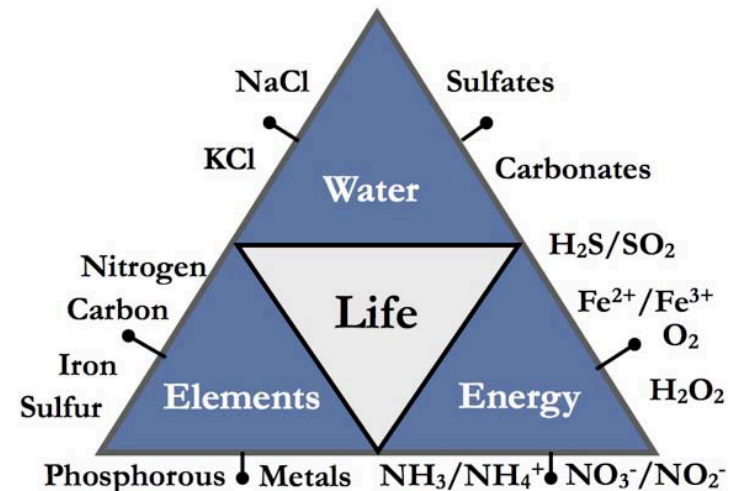

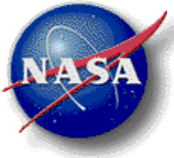

# Europa Lander Mission

- Lander Design
  - Phoenix-like lander
    - Actuated lander legs to handle uneven terrain
  - Mast-camera; pan-tilt head, stereo pair
    - Limited FOV
    - Cameras and antenna mounted on same platform
  - 5-DOF Robot Arm
    - Limited reachability area due to landing struts, arm location
    - End effectors: drills, scoops, saws, perhaps 'hand-lens'
  - Instrument vault
    - External: arm transfer to vault entrance
    - Internal sample transfer plus physical / chemical instrument suite



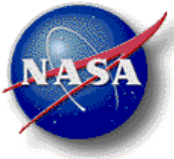

# Europa Lander Mission

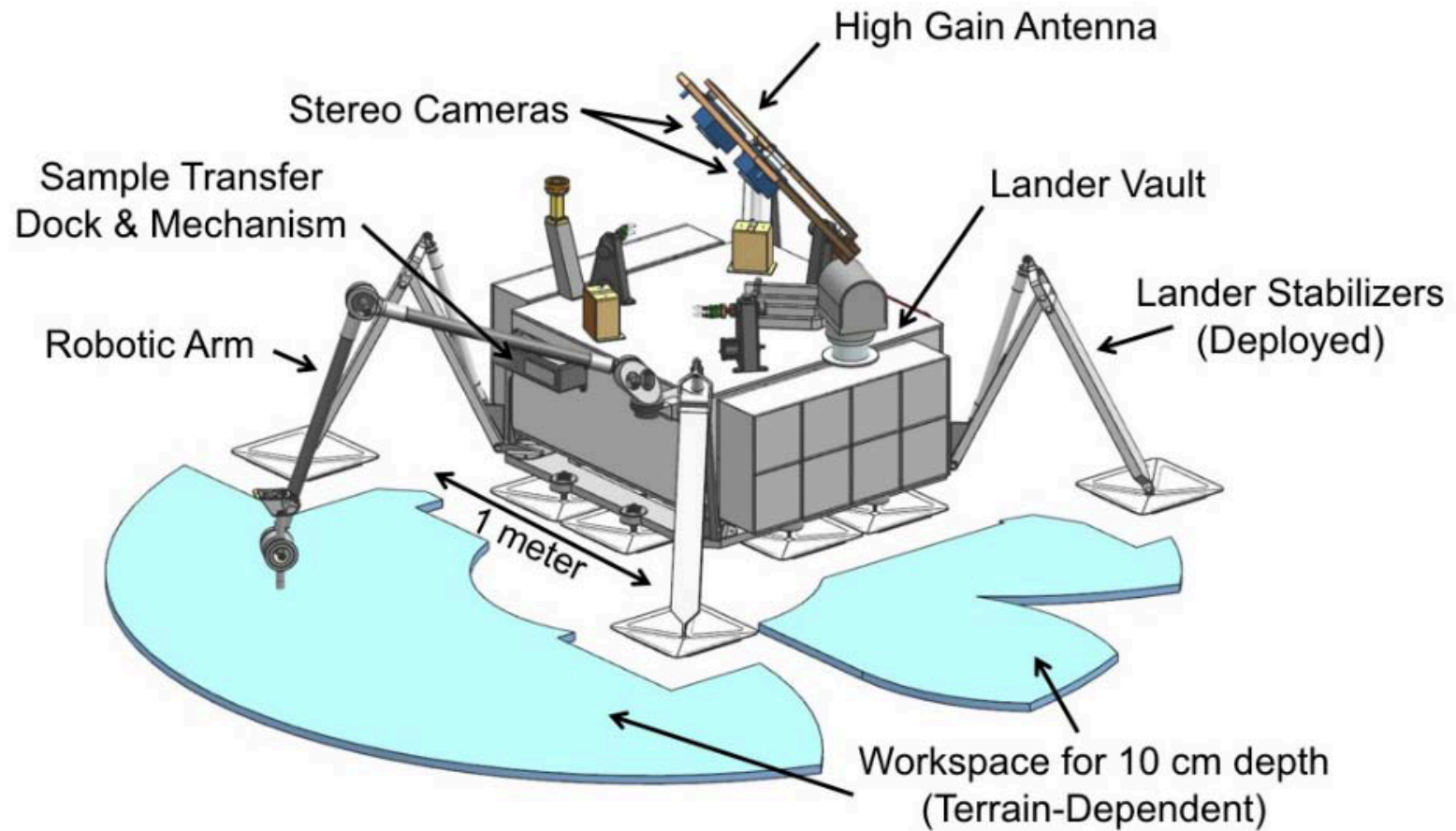

Europa Lander Science Definition Team Report  
2016

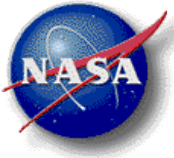

# Europa Lander Mission

- Mission Design and Operational Constraints
  - Lander and Carrier Relay Orbiter (CRO)
  - 20 day mission lifetime (expected CRO survival)
  - Periodicity of Earth-vehicle communications: ~2 days (30 - 60 minute delay)
    - CRO in view of lander for 10 hrs of every 24
    - CRO in view of Earth every ~8 hours of every 24
  - Collect and analyze 5 samples
    - 10 cm below-surface sampling (driven by radiation penetration depth)
    - Sampling that maintains  $< -120^{\circ}\text{C}$  sample temperature

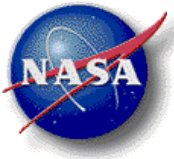

# Europa Lander Mission

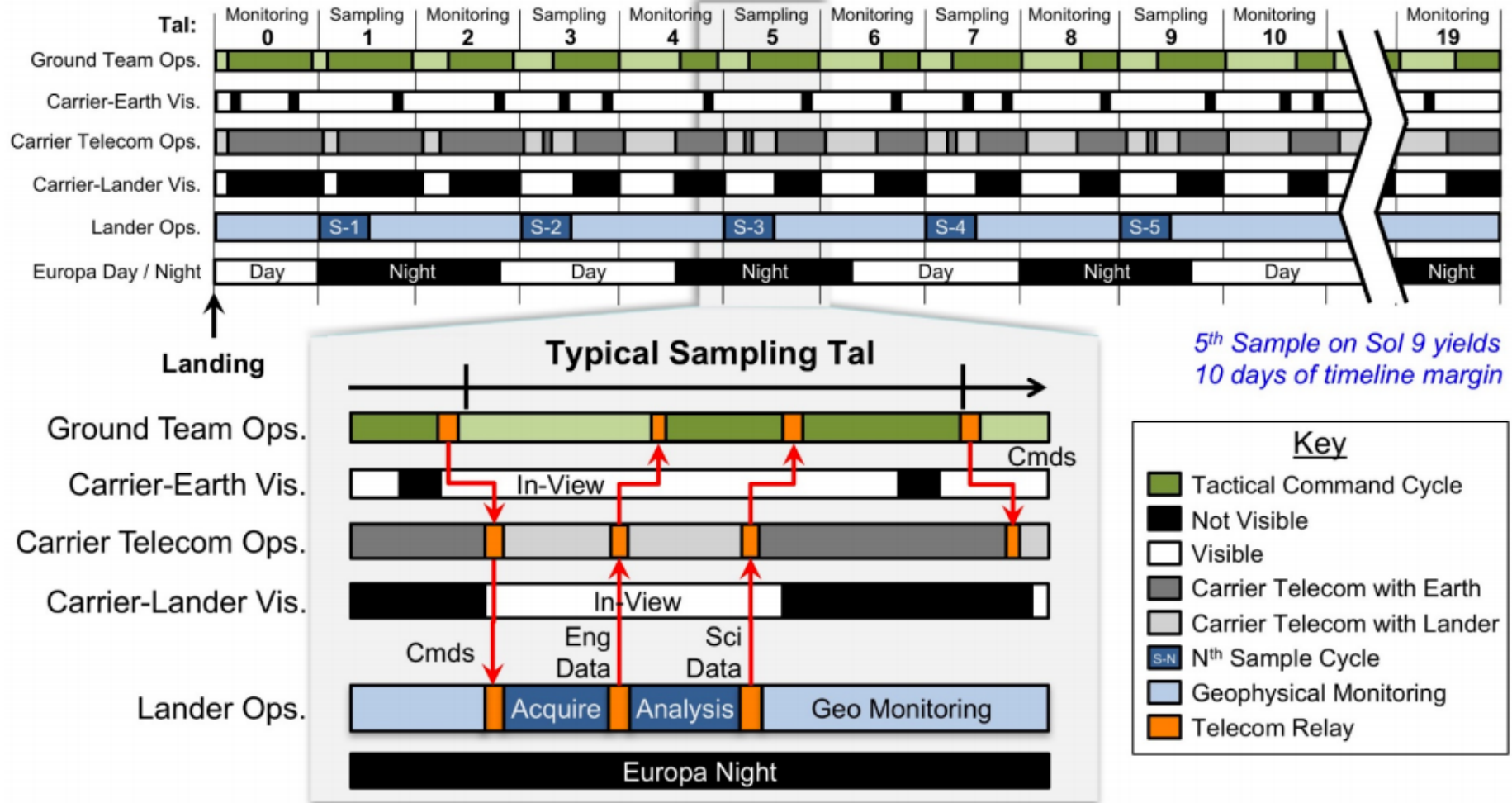

**Figure 9.3.** The Nominal Surface Mission plan includes completion of final sample analysis on Tal 9, with 10 tals of time margin booked as Monitoring Tals.

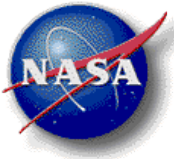

# Europa Lander Mission

Per-sample activities (could be over 2 days) include:

- Look at the site survey data and last known arm and camera positions.
- Decide which location to sample next, integrate results of the prior sample and any changes in environmental conditions (unlikely) or spacecraft degradation (much more plausible).
- Construct and validate command sequences.
- Move robotic arm
- Access subsurface
  - (sawing, drilling)
  - collect sample (catching, scooping)
- Transfer sample to instruments
- Analyze sample
- Store and transmit data
- Uplink new command sequence
- Manage faults throughout

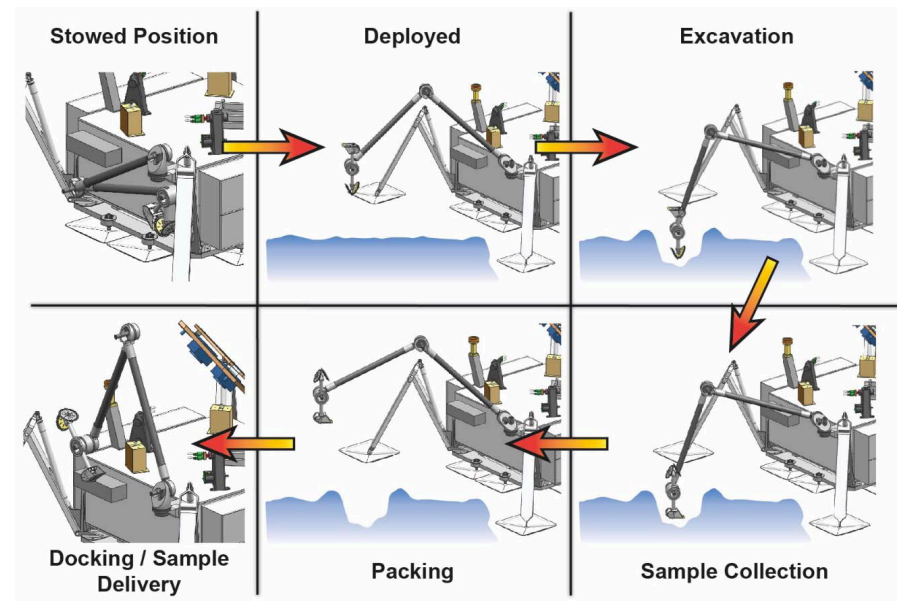

Europa Lander Science Definition Team Report  
2016

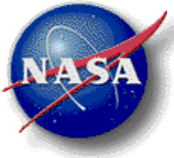

# Autonomy Challenges

- Autonomy for the proposed mission
  - Entry, descent and landing: computer vision, control
  - Site survey: computer vision
  - Sampling: Arm motion plan execution
  - Internal science processing: vision, process control
  - Throughout: Fault management
- Autonomy for future missions
  - Autonomous science targeting
  - Arm motion planning
  - Vehicle level planning



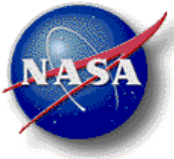

# Autonomy Challenges: Deorbit, Descent and Landing

Best resolution  
picture of  
Europa's surface  
(6 m/pixel –  
Galileo)

- Sun relatively high in sky
- Brightness variations largely due surface material rather than shadows.

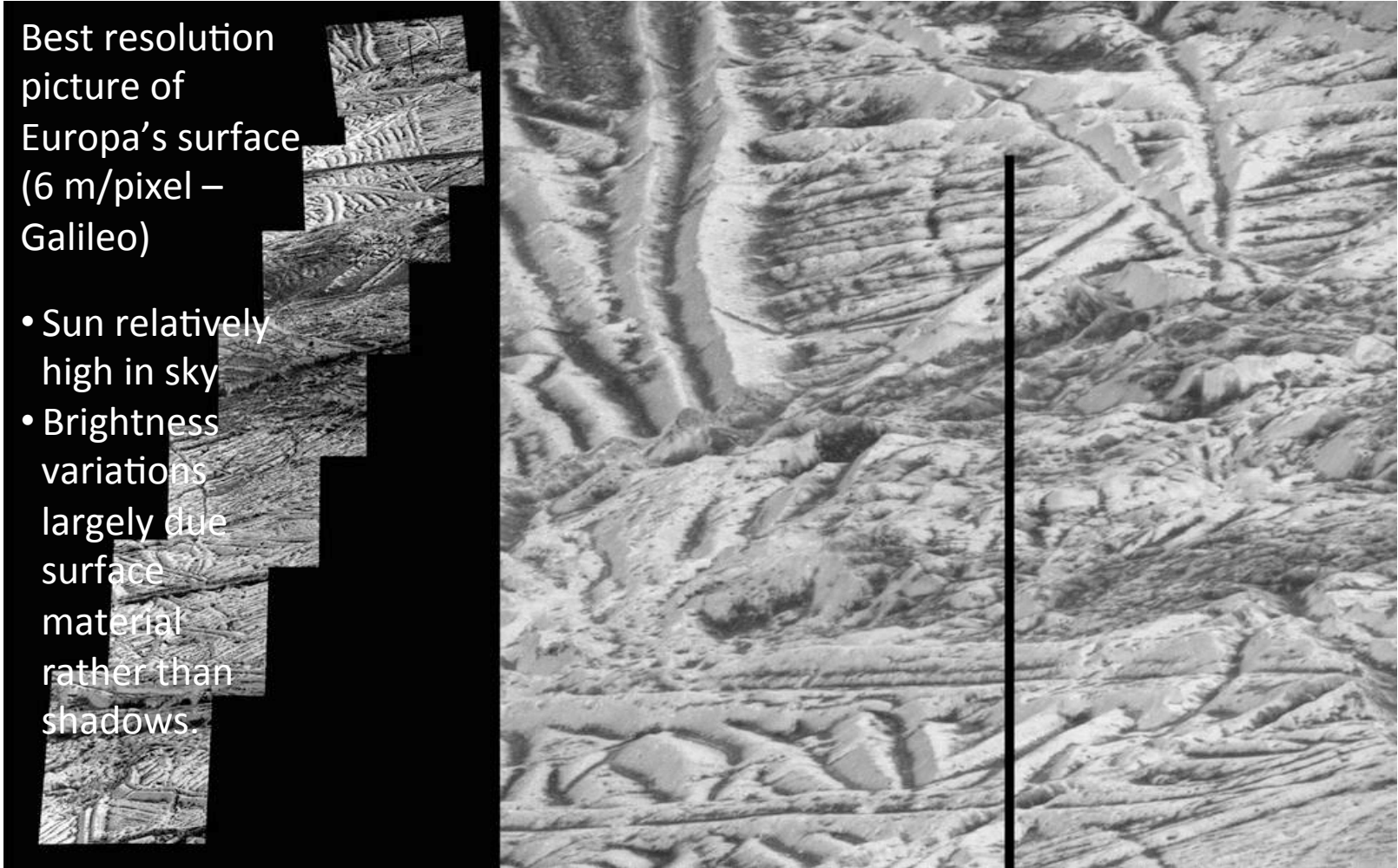

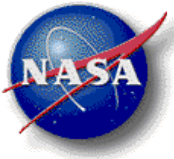

# Autonomy Challenges: Deorbit, Descent and Landing

- State of the Practice:
  - MER-DIMES
  - Curiosity Sky-Crane
- Challenges:
  - Science desires landing in 'rough' regions
  - Shadows eliminate polar landing sites
  - Trajectory / velocity constraints eliminate some equatorial landing sites
  - Limited prior imagery
  - Limited prop for landing
  - Illumination challenge (25X dimmer than Earth!) (longer exposure times more of a problem!)

Europa Lander Science Definition Team Report  
2016

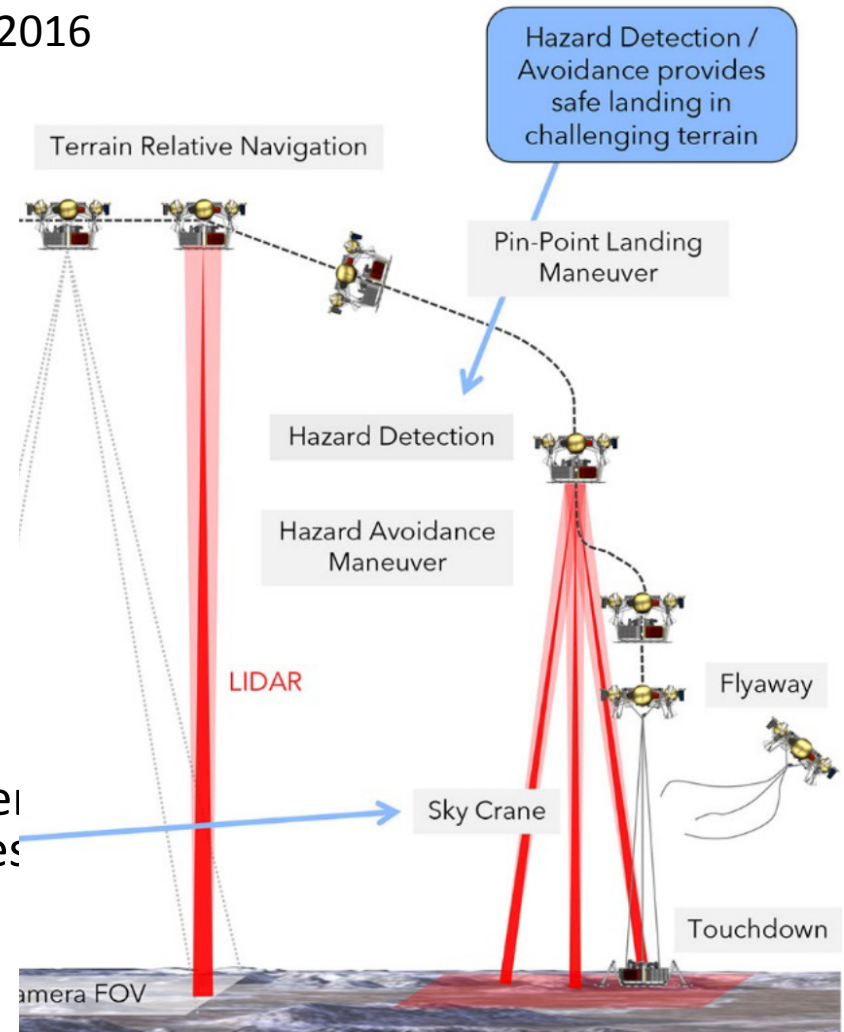

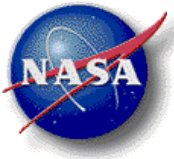

# Autonomy Challenges: Site Survey and Target Selection

- State of the Practice:
  - Curiosity
  - Spirit, Opportunity
  - Phoenix

- Challenges:
  - Lighting (25X dimmer than Earth)  
(longer exposure times less a problem)
  - Cold (-120C at equator; contrast with [-90,-20]C for Phoenix; mast camera fault risk
  - Heterogeneous camera design / multiple imaging modes
  - Radiation; mast camera fault risk (see above)
  - Autonomous integration of heterogeneous res data
  - Autonomous Science: decades to build Mars Target Library, we don't have that kind of database for Europa, and don't have that kind of time!

Europa Lander Science Definition Team Report  
2016

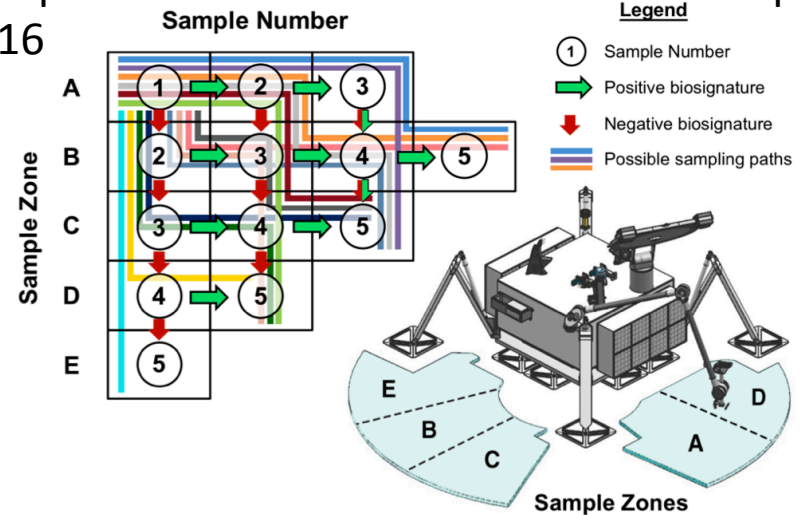

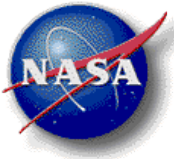

# Autonomy Challenges: Site Survey and Target Selection

- Features of life via “difference detection”: what varies in the image?

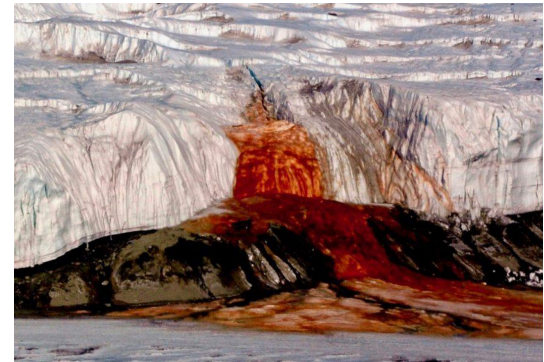

Antarctic ‘blood falls’: an iron-rich bacterial soup!

- SDT p.142: CRSI instrument
  - Visual features of life. (shape and color)
  - Spectrometers could be added to design but are not part of baseline.)
  - NIR could be added to design but are not part of baseline.)

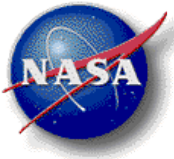

# Autonomy Challenges: Site Survey and Target Selection

- Some other items relevant to the vision system
  - Change detection (SDT p. 149-150)
    - Surveys / monitoring
  - Coarse vs fine grained image acquisition
    - And Change Detection!
  - Autonomous detection of 'normal' vs 'not-normal'
    - Can start with descent imagery
  - How can descent imagery, surface imagery, radar data be used together to do target selection onboard?



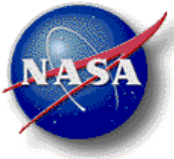

# Autonomy Challenges: Phoenix Arm Planning and Ops

- Does
  - Expansion of high-level task commands (e.g., dig);
  - Arm operation modes
    - Guarded moves (move until contact)
    - Accommodation (can retry dig operations)
  - Generation of arm movement trajectories
  - Validation of collision-free motion paths;
  - Fault detection and recovery
    - Evaluates resources, time
- Does not
  - Fail operational
  - Do system wide fault isolation
  - Invoke planner when fault occurs
  - Try to validate position if there is a problem
  - Try to validate terrain

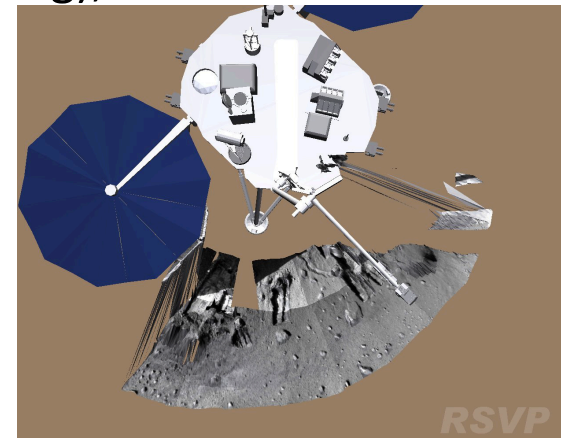

Phoenix. Bonitz et al. 2008

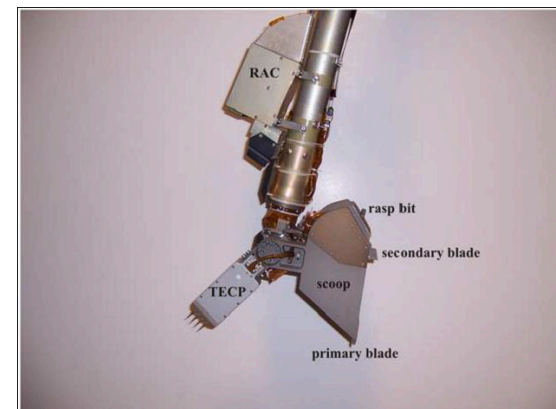

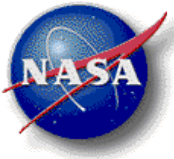

# Autonomy Challenges: Arm Motion Planning

- State of the Practice:
  - Curiosity
  - Spirit, Opportunity
  - Phoenix
- Challenges:
  - Uncertainty in terrain
  - Unknown lander pose
  - Arm pose/geometry uncertainty
  - Guarded moves/ Accommodation in icy terrain
  - Fail operational fault management

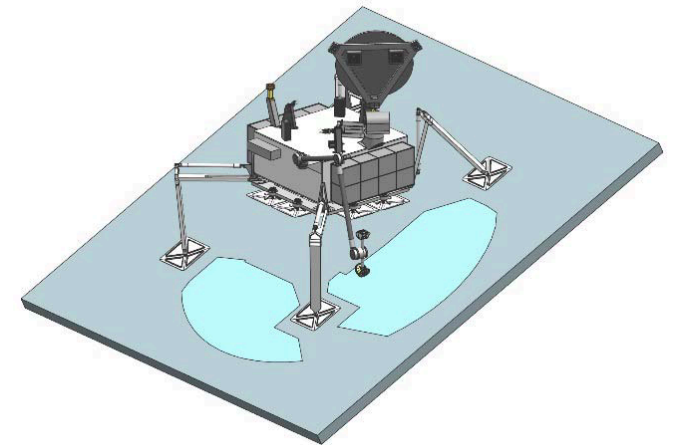
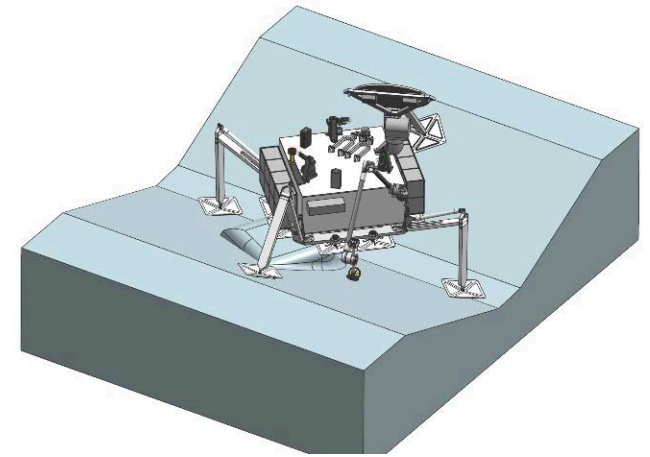

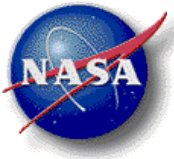

# Autonomy Challenges: Arm Motion Planning

- More on the challenges:
  - Terrain uncertainty due to poor lighting
  - Arm pose uncertainty due to lander pose, encoder granularity, true arm geometry (bending)
  - Arm pose estimation uncertainty due to poor lighting
  - Unstable lander pose / slippage
  - Arm faults: transient, permanent
  - Distinguishing arm faults from interaction w. terrain
  - How to determine if terrain is 'hard' 'soft' from available data
  - Arm motion to take image of sample with mastcam (SDT p. 264)

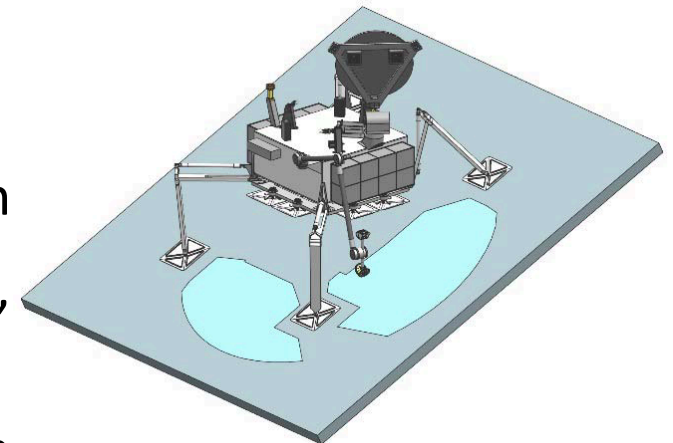
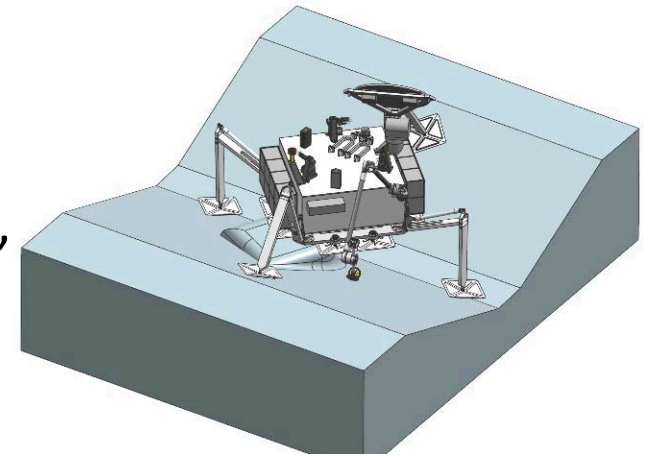

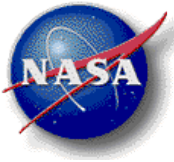

# Autonomy Challenges: End Effector Operations

- State of the Practice:

- Curiosity
- Spirit, Opportunity
- Phoenix

- Challenges:

- Uncertainty in terrain
- Unknown lander pose
- Unknown surface composition hardness (e.g. dig a penitente?)
- Reacting to sample transfer issues (e.g. ice freezing / melting in scoop)
- End Effector faults (rasp or saw)
- Integrating data from end effector operations into model of environment for next sampling / end effector operation

Europa Lander Science Definition Team Report  
2016

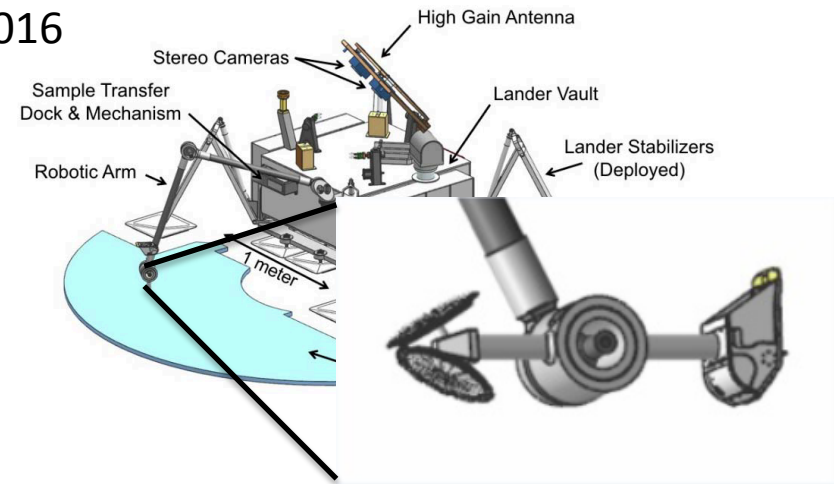

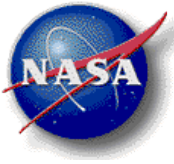

# Autonomy Challenges: Sample Analysis at Mars

- Curiosity payload
  - Many ways to contain, move, treat gas; 3 analyzers plus everything else
  - Many ways to contain, move, treat gas; 3 analyzers, 50 valves, scrubbers, getters, traps, pyrolyzers, and a robotic solid sample manipulation system
  - Power, thermal and other resource constraints in addition to science goals needed to be respected when operating the instrument.
  - Variety of process flows is being put to use now as more known about environment and soil content and atmosphere
- Does:
  - Accept as input program/script for experiments
  - we make decisions based on instrument status, sensor readings, and external conditions
  - Analyses can take up to 9 hours
- Does not:
  - Fail operational
  - Do system wide fault isolation
  - Invoke planner when fault occurs
  - Many faults lead to termination

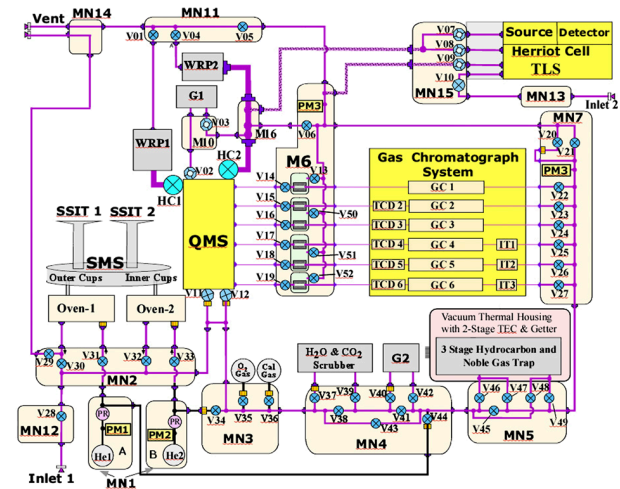

SAM schematic. Mahaffy et al. 2012

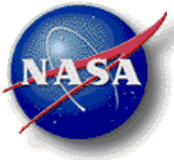

# Autonomy Challenges: Instrument Operations

- State of the Practice:
  - Curiosity
  - Spirit, Opportunity
  - Phoenix

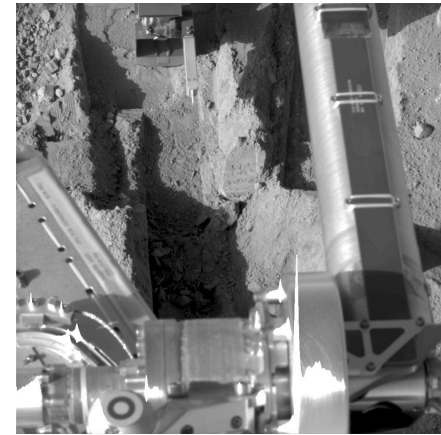

Phoenix sample acquisition.  
Bonitz et al. 2008

- Challenges:
  - Uncertain sample availability
  - Uncertainty in desired science objectives and science protocols to achieve them
  - Uncertain operating environment and limits
    - Caution early in Curiosity mission led to many premature terminations
  - Adapting instrument operations based on prior operations
  - Updating model of environment based on sample analysis outcomes
  - And, of course...faults!



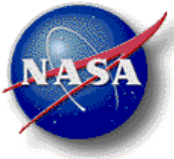

# Autonomy Challenges: Strategic Planning

- State of the (ART) Practice:
  - EO-1 ASE
  - Mars 2020 (Chien's talk)
- Challenges:
  - Nominal planning can be compl (e.g. can't use camera and communicate simultaneously)
  - Reactive planning: Learning from samples
  - Reactive planning: Reacting to Events (plumes)
  - Reactive planning: replanning after faults

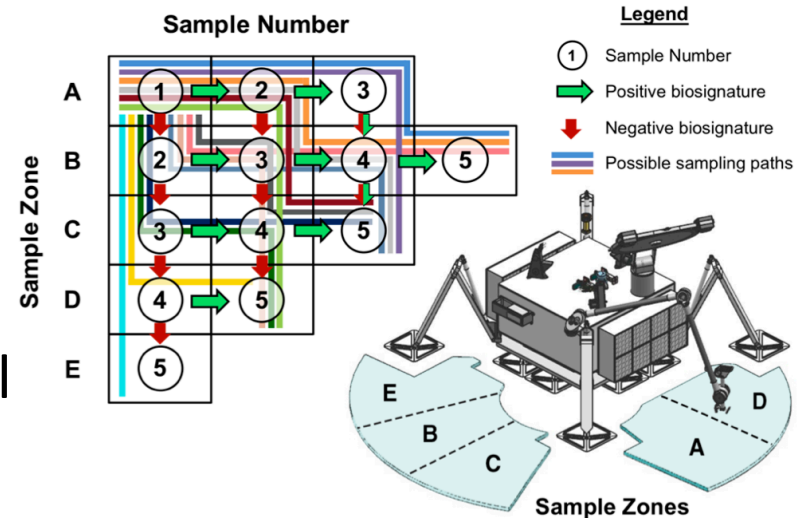

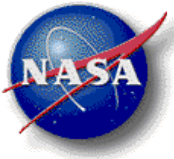

# Autonomy Challenges: Fault Management

- State of the (ART) Practice:
  - L2 on EO-1
  - Phoenix (Arm)
  - Curiosity (SAM)
- Challenges:
  - Faults vs anomalies
  - Fault limits
  - Transient vs permanent faults
  - Faults vs terrain uncertainty

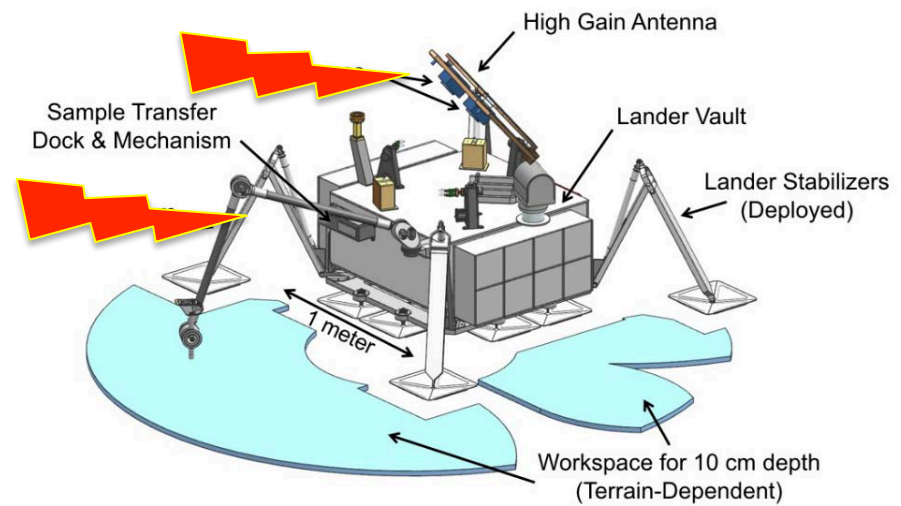

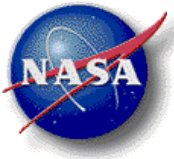

# Autonomy Challenges: Fault Management

- Faults of interest: Camera
  - hot pixels? Snow/ice? Loss of baseline?
  - Fault tolerance of a ‘heterogeneous’ camera head
    - What happens if you lose the high-res?
    - What happens if you lose the low-res? (panos are more expensive)
- Faults of interest: Arm
  - Loss of motion on joint, loss of data from joint, bending/deformation of arm

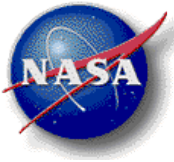

# Autonomy Challenges: Fault Management

- Faults of interest: End effector
- Faults of interest: Vault
- Faults of interest: Avionics
  - ?
- Faults of interest: Power system
- Faults of NO interest:
  - Loss of comm
  - Loss of avionics
  - Catastrophic pose (fall over)



Phoenix sample bin door faults. Bonitz et al. 2008

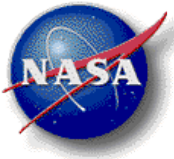

# Autonomy Challenges

- Practical matters
  - RSVP is ~1M lines of code. How are you going to run that on a PPC 750?
    - Not all of that 1M needed onboard...lots is graphix 😊
  - RSVP: if you need to acquire more polygons for collision detection how are you going to handle that? Dynamic memory alloc? Mere processor size/performance?
  - What if you need to approximate? Or bound? How can you do that safely?
  - Strategic planning is no different
  - V&V of autonomy: validating conditional plans
  - V&V of autonomy: faults / transients / new polygons

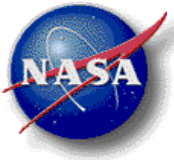

# Autonomy Challenges

- Practical matters
  - How are you going to store all the image data?
    - Is it even possible?
  - How are you going to store all instrument data from vault?
    - Example: SAM has thousands of parameters. Hours long analyses. Can you afford to delete after analysis done?
  - Comm bandwidth would be reduced
    - How much SWaP would that save?
    - ...and would it actually be reduced? Scientists want every piece of data; see above
  - Onboard production of elevation maps required
    - Already considered as comm reduction (SDT p. 150)



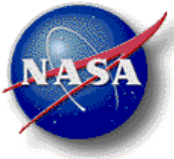

# Autonomy Challenges

- Autonomy Integration
  - Integration of execution and fault management
  - Integration of execution and vision/target system
  - Integration of different planning algorithms and fault management
  - Integration of vision system and kinematics planning
- Considerations
  - Semantic / theoretical: what information must be exchanged between components?
  - Practical: what are the interfaces between components? What component is in charge? What is the control flow?

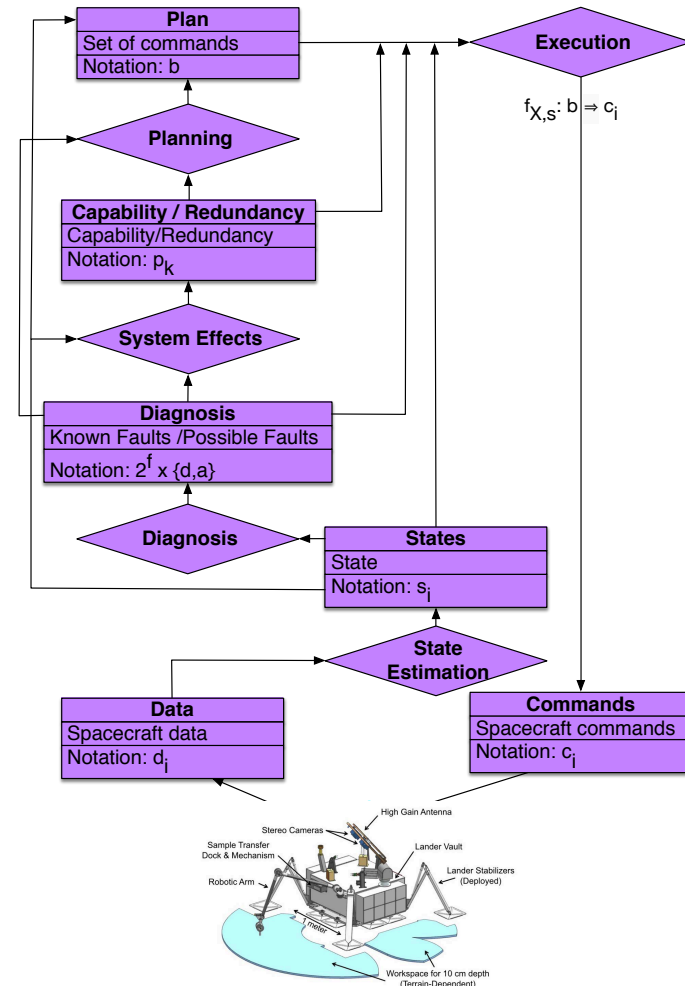

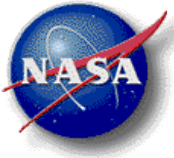

# Autonomy Challenges

- Data Fusion
  - Multi-scale visual data (Previous missions, Descent imager, stereo images of different resolution, images and radar)
  - Folding science data back into terrain map
  - Folding end effector data back into terrain map

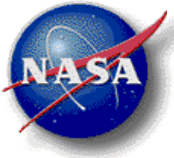

# Autonomy Challenges

- Learning and Adaptation
  - Learning how to relax limits (e.g. fault protection too aggressive)
  - Learning how to restrict (e.g. experienced fault when didn't expect to)
  - Learning good science models for targeting (see above)
  - Learning how to operate instruments in vault (SAM)

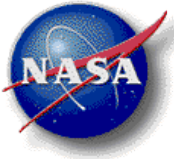

# References

- Europa Lander Study 2016 Report.
  - <https://europa.nasa.gov/resources/58/europa-lander-study-2016-report/>
- Europa Lander Science Payload Draft Proposal Information Package.
  - [https://nspires.nasaprs.com/external/viewrepositorydocument/cmdocumentid=628861/solicitationId=%7B17B73E96-6B65-FE78-5B63-84C804831035%7D/viewSolicitationDocument=1/Europa\\_PIP\\_Draft15v3.pdf](https://nspires.nasaprs.com/external/viewrepositorydocument/cmdocumentid=628861/solicitationId=%7B17B73E96-6B65-FE78-5B63-84C804831035%7D/viewSolicitationDocument=1/Europa_PIP_Draft15v3.pdf)
- Bonitz et al. The Phoenix Mars Lander Robotic Arm. Proc. IEEE Aerospace Conference, 2009.
- Mahaffy et al. The Sample Analysis at Mars Investigation and Instrument Suite. Space Sci Rev (2012) 170:401–478
- Lee et al. Indirect and Direct Planetary Illumination Modeling for Robotic Surface Exploration Sensing. Proc AIAA Space 2016. Chien, S., Sherwood, R., Tran, D., Cichy, D., Rabideau, G., Castano, R., Davies, A., Mandl, D., Frye, S., Trout, B., Shulman, S., Boyer, D., “Using Autonomy Flight Software to Improve Science Return on Earth Observing One”, *Journal of Aerospace Computing, Information, and Communication*, v. 2, April 2005 .
- Hayden, S.C., A.J. Sweet, S.E. Christa, D. Tran, and S. Shulman. 2004. Advanced Diagnostic System on Earth Observing One. In Proceedings of AIAA Space Conference and Exhibit, San Diego, California, Sep. 28–30, 2004.
- Integrated Planning and Execution for a Self-Reliant Mars Rover. Steve Schaffer, Joseph Russino, Vincent Wong, Heather Justice and Daniel Gaines. Proc. Integrating Planning and Execution Workshop, 2018
- Goesman et al. Organic compounds on comet 67P/Churyumov-Gerasimenko revealed by COSAC mass spectrometry. Science, Vol. 349, Issue 6247, 31 Jul 2015.

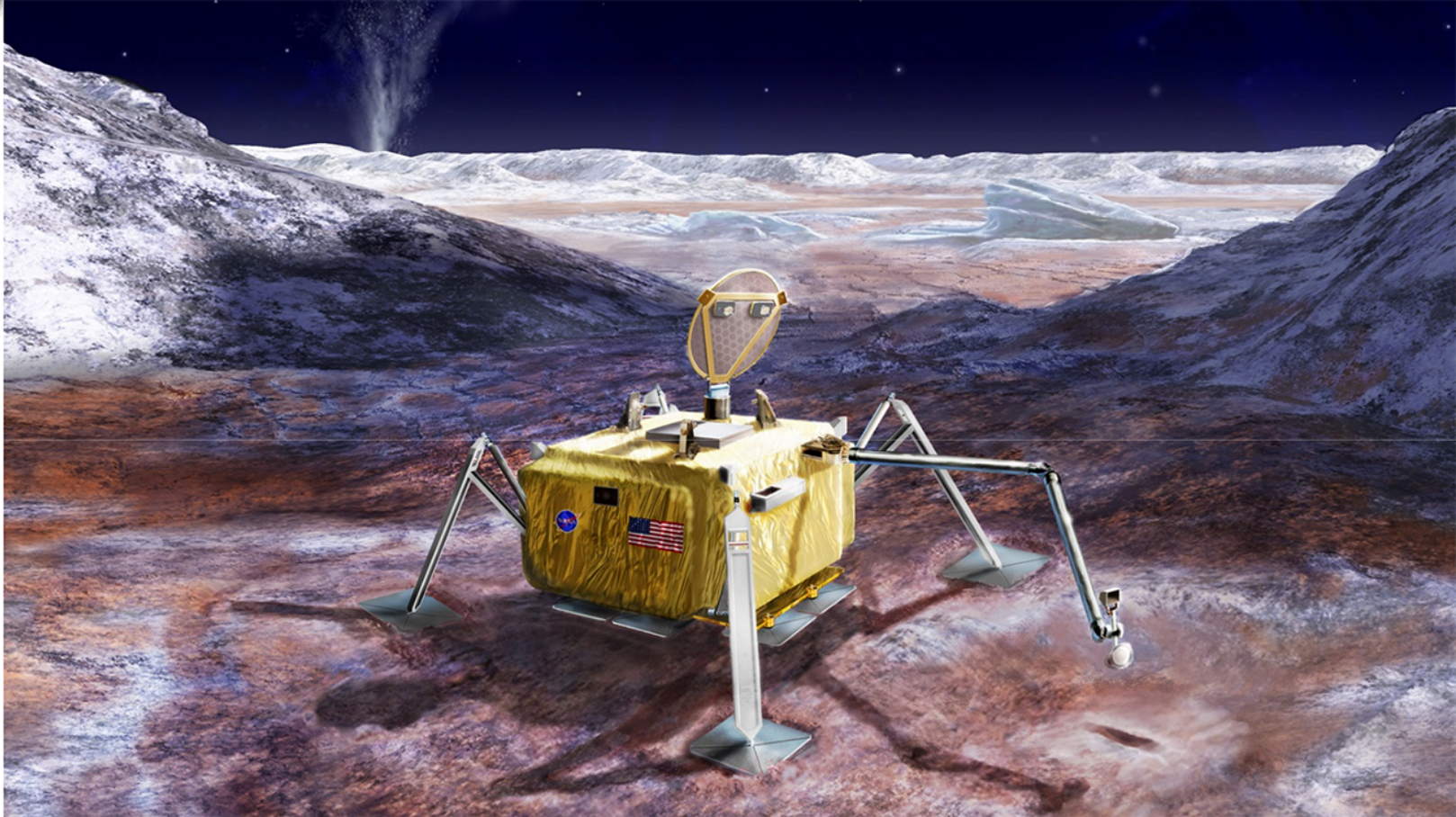

Thank you!

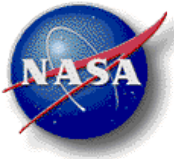

# Autonomy Challenges

- Other Missions where lessons could be learned
  - Cassini, Juno and Europa Clipper
  - Dawn (wait what? Fault Mgt)
  - Spirit / Opportunity (wait what? MER DIMES)
  - Mars surface (wait what? Mars science catalog)
  - Biosentinel (wait what? Autonomous analysis of samples, microfluidics etc)
  - Curiosity (wait what see above)



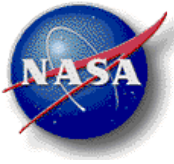

# Relevant Mission Challenges

## Environment

- Surface roughness and composition
- Unknown surface
- Sample composition: pure ice, pure salt, acidic
- Radiation (avionics resets)
- Albedo/lighting

## Science requirements

- 10 cm below-surface sampling\*
- Sampling that maintains  $< 150$  K sample temperature

## Operations

- Limited duration (20 days)
- Limited communication windows (10 hours first day, 2 day blackout)
- Poor predictability of activity durations
- Delivering sample to particular instrument interfaces\*\*
- Impact of cryo-vac on sampling and sample handling



# Notional Europa Lander Mission

**Launch:** late 2025    **Land:** December 2031

## Level 1 objectives

- **20 – 30 days** on the surface (battery constrained)
- Collect samples from at least **5 regions** (2 m<sup>2</sup> reach)
- Acquire and analyze **5 samples** (7 cm<sup>3</sup>) from **10 cm below the surface**
- Telemeter data back to Earth via a dedicated Carrier Relay Orbiter

## • Additional details

- 10 hours of continuous communication coverage (surface to CRO)
- CRO expected to last 30 days
- Periodicity of Earth-vehicle communications: ~2 days (45 minute delay)

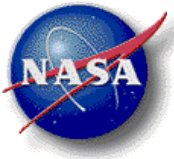

# Notional Europa Lander Concept of Operations (I)

- 2 days of on-surface checkout for communications health, lander health, and so on.
- 2 days of ops of surface equipment such as robot arms, cameras, remote sensors.
- 6 days of intensive site survey and target planning for each of the 5 samples.
- 10 days of sampling activity. 1 sample can be taken and analyzed every 2 days.

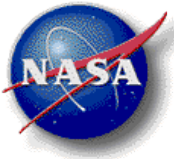

# Notional Europa Lander Concept of Operations (II)

Daily or per-sample activities include:

- Look at the site survey data and last known arm and camera positions.
- Decide which location to sample next, integrate results of the prior sample and any changes in environmental conditions (unlikely as that seems given what I am reading about Europa's surface conditions) or spacecraft degradation (much more plausible).
- Construct and validate command sequences.
- Move robotic arm
- Access subsurface (sawing, drilling) and collect sample (catching, scooping – driven by need to keep sample at  $< 150$  K or 10 K above surface)
- Transfer sample to instruments
- Analyze sample
- Store and transmit data
- Uplink new command sequence
- Manage faults throughout

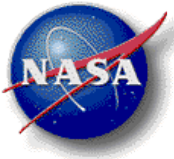

# References

- [https://www.youtube.com/watch?v=sVlzP\\_eFdJw](https://www.youtube.com/watch?v=sVlzP_eFdJw)
- <https://www.nasa.gov/feature/nasa-receives-science-report-on-europa-lander-concept>
- [https://en.wikipedia.org/wiki/Europa\\_Lander\\_\(NASA\)#Instruments](https://en.wikipedia.org/wiki/Europa_Lander_(NASA)#Instruments)
- [https://solarsystem.nasa.gov/docs/Europa\\_Lander\\_SDT\\_Report\\_2016.pdf](https://solarsystem.nasa.gov/docs/Europa_Lander_SDT_Report_2016.pdf)
- [https://descanso.jpl.nasa.gov/DPSummary/Juno\\_DESCANSO\\_Post121106H--Compact.pdf](https://descanso.jpl.nasa.gov/DPSummary/Juno_DESCANSO_Post121106H--Compact.pdf)



# References

- <https://www.telegraph.co.uk/news/worldnews/northamerica/usa/2078982/Nasas-Phoenix-Mars-Lander-fails-to-scoop-up-sample-of-Martian-soil.html>
- <https://www.telegraph.co.uk/news/2038974/Mars-mission-hitch-as-Phoenix-Lander-sheath-fails-to-unfurl.html>
- <https://www.leonarddavid.com/curiosity-encounters-robotic-arm-fault/>
- <http://www.planetary.org/blogs/emily-lakdawalla/2017/0906-curiosity-balky-drill-problem.html>



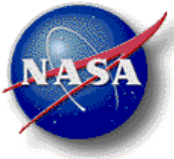

# References

- <https://saturn.jpl.nasa.gov/news/3020/the-moon-with-the-plume/>
- [http://www.esa.int/Our Activities/Space Science/Rosetta/The Rosetta lander](http://www.esa.int/Our_Activities/Space_Science/Rosetta/The_Rosetta_lander)
- <https://spacenews.com/europa-lander-concept-redesigned-to-lower-cost-and-complexity/>
- [http://sites.nationalacademies.org/cs/groups/ssbsite/documents/webpage/ssb\\_185049.pdf](http://sites.nationalacademies.org/cs/groups/ssbsite/documents/webpage/ssb_185049.pdf)
- [https://planning.jpl.nasa.gov/public/papers/verma\\_iwpss2017\\_autonomous.pdf](https://planning.jpl.nasa.gov/public/papers/verma_iwpss2017_autonomous.pdf)

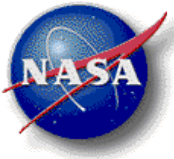

# Europa Autonomy Virtual Testbed

- This is a virtual testbed to evaluate autonomy approaches or solutions that can perform some or all of the Lander daily activities in light of failures or unexpected interactions with environment.
- The key simulation capabilities needed to demonstrate autonomy for the limited mission objectives described above include:
  - **Europa Environment**: surface characteristics, surface geometry, lighting and shadow, temperature, and potentially radiation
  - **Lander design**: Bulk lander geometry, mast, mast camera designs, lander arm, end effectors (buzzsaw, scoop)
  - **Uncertainty**: lander pose, true vs acquired imagery, true vs perceived arm position, predicted vs amount of sampled material
  - **Faults**: camera faults, mast faults, robot arm faults, avionics faults. Possibly also CRO / communication system faults.
- Level of Effort Discriminators:
  - Simple terro-mechanics vs Complex terro-kinematics
  - Sophistication of camera design (single camera vs multiple cameras)
  - Range of arm activities (collect and move samples vs collect, move, dump samples)

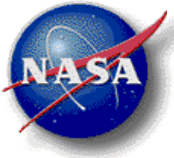

# Questions

- Carol: why no camera on arm? Very useful: look under lander (important for Phoenix), allows other flexibility.
  - JP: if you show how valuable an arm camera is to mission with testbed, they'd listen.
- Can we look at different sampling strategies?
  - LIDARS?
- How do we vary levels of autonomy?
- How do we do adaptive sampling?
- How can we predict how long ops will take?
  - Does sample acquisition depend on geometry and lighting (ground vs ridge / side of penitente)
  - shadowed regions protected from radiation as preference
  - Tie this back to autonomy? Learn action duration?



# Questions (science sim stuff)

- By the way, I don't think Lake Vostok is a good analog of the surface to be encountered for a variety of reasons. Just because there is an ice cover over a lake, does not make for a good surface analog. Most lake ice on Earth is dominated by the effects of wind ablation which would not occur.
- I don't know if you caught the seminar by Pascale Ehrenfreund a week ago. She showed many pictures and talked about the surface of the comet visited by the Philae lander. This surface was complex even at the microscopic level and underdense even at that level. I think a real good physics based modeling of the surface based on the best available modeling tools for sublimation degradation combined with radiation damage is needed.
- The two environmental parameters of keen interest in the vault will be radiation — not only total dose, but the dose rate as a function of LET spectrum — and temperature. To simulate those parameters, you'd need an estimate of the masses and distribution of materials that comprise the lander, along with the total energy budget and some starting assumptions about radiation shielding and thermal insulation plans.
-

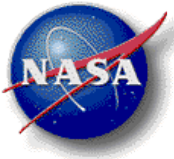

# Notional Europa Lander Concept of Operations (I)

Europa Lander SDT p. 9-8:

- **Autonomy:** A sample cycle is expected to be a fully autonomous sequence of events and performed with no real-time interaction with Earth. Once begun, the sample cycle would go through each of the defined steps, with the sample provided to each instrument in turn, without an intervening ground cycle. Consequently, within a sample cycle, instruments are expected to perform all activities without ground intervention and within their time allocation
- **Time:** The most constraining class of trajectories for the carrier relay orbit results in approximately 10 hours of line-of-sight coverage per tal between the carrier and lander. To support ground-in-the-loop commanding, each over-flight would need to include both forward and return links for the lander, which in turn could limit the duration of a sample cycle to 10 hours. Data considered decisional must be ready to transmit by the end of the sample cycle. Instruments that are not producing decisional data may continue to operate subject to their thermal, data, and power constraints. (Refer to Table 9.3 for the definition of decisional data.)
- **JDF note:** Earth-Jupiter communication delay of 33-53 mins

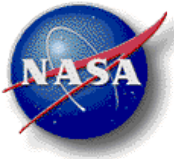

# Various other stuff

- Vision
  - Computer vision systems either for structured or unstructured, not both
  - Arm pose: uses fiducials (see Larry email)
  - Can a single vision system do both? How?
  - Phoenix sample transfer (dumping dirt was a problem because samples heated up)
  - Soft vs hard: want to know before you do sample transfer \*and\* before you deploy / activate end effectors
- Unexpected events
  - P67 plume was unexpected

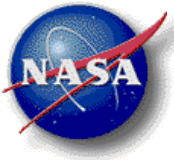

# Juxtapose this w. autonomy challenges...

Per-sample activities (could be over 2 days) include:

- Look at the site survey data and last known arm and camera positions.
- Decide which location to sample next, integrate results of the prior sample and any changes in environmental conditions (unlikely) or spacecraft degradation (much more plausible).
- Construct and validate command sequences.
- Move robotic arm
- Access subsurface
  - (sawing, drilling)
  - collect sample (catching, scooping)
- Transfer sample to instruments
- Analyze sample
- Store and transmit data
- Uplink new command sequence
- Manage faults throughout

Per-sample activities (could be over 2 days) include:

- What's next most interesting locale?
- Where's the arm?
- Based on what's been done so far what is known what resources we have what is the next best place to sample? Can plan be generated to sample there? If not what to do about that?
- Construct and validate command sequences.
- What if you can't? Fault? Bad data? ???
- Access subsurface
  - (sawing, drilling)
  - collect sample (catching, scooping)
- Transfer sample to instruments
- Analyze sample
- Store and transmit data
- Uplink new command sequence
- Manage faults throughout



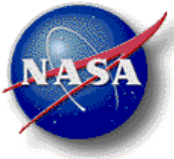

# Tom Nolan

- Software architect / developer for SAM instrument, had developed flight software for other instruments. SAM was very different than particle detectors (mass spec vs particle detector) Hard to come up with theory of ops since scientists didn't know exactly what they wanted; wanted lots of flexibility. Brand new instrumentation, never been tested, no one knew how it would work in practice.
- Briefly involved in Europa lander; autonomy clearly a focus of proposal. Greater autonomy challenges than Mars. Can still operate on samples with one day's turnaround. (This is not inconsistent with Europa concepts)
- Thoughts about simulator: best thing as instrument designer would be to have such a thing available to simulate lander in its environment and allow instrument to test its autonomous ops and recovery ability
- SAM: it has some autonomy that weren't built into prior instruments. Started because SAM is collection of gas analysis tools similar to chem lab on Earth:
  - Many ways to contain, move, treat gas
  - 3 analyzers plus everything else
  - Can be run in many ways: split gas and analyze serially or simultaneously flows, etc.
  - Variety of process flows is being put to use now as we learn more content and atmosphere
  - Basic surveys followed up with more sophistication

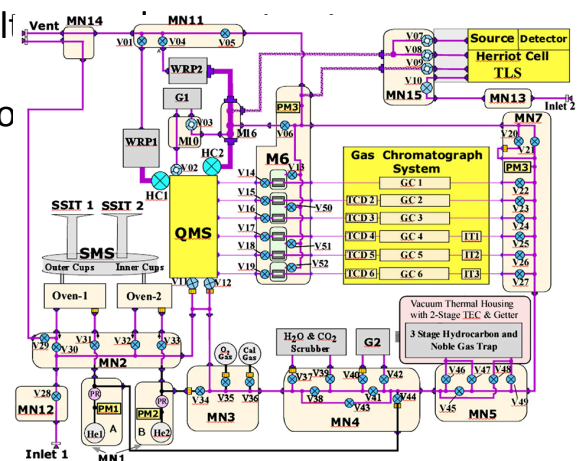

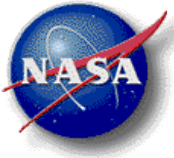

# Tom Nolan

- Design

- Created scripting language atop flight software. Expose the basics. Allow scripting commands. FSW would do the rest.
- Led to idea that scripting the process required exposing data: what is state of instrumentation? What is outside? Need to monitor for various limits, build in contingencies, etc. This is where autonomy/automatic control comes in.
- Scripting language is old BASIC (!) Good choice, scientists can write / design scripts, has full features of programming language, etc. One way to think of h/w primitives is that there is a script command to control each knob / dial / etc. Time critical items (PID controllers, etc) have FSW tasks, each task can be started/ stopped by a script command and feedback on state (are you at temp yet, etc). Every instrument has HK data (temps, voltage, currents, pressures) and science data. This data also fed back to script. Big table with elements and array index etc. Script can reference global state in this array. That's the architecture.
- Scripts were complex in practice! Duh. Scripts are big (thousands of lines for 3-4 hour process).
- Scripts can do contingent execution on failure to reach state, errors in FSW that are pertinent, etc.
- Even though Mars is pretty benign. Script language allows decisions to be made in presence of errors and faults, but the usual response was simply to safe the instrument and notify rover. Some things were handled. Example: if temp setpoint not reached, may simply 'waive' requirement and continue; make some analyses contingent on reaching setpoints.
- Scientists decision when reached mars: be cautious. Strict limit checks early in mission. Basically every time you turned on SAM would safe. Got a bad rep with the team for this reason; rover team needed days to get back in action. Became more confident and now things are going gangbusters. Found lots of things and adapted to them. (Examples?) The 3 hour analyses are now working very reliably.
- Another bad thing: instrument commands are not 'traditional': usual idea is an opcode and commands, but SAM commanded by sending a big ol' ASCII script. File transfer to rover, rover sends those files to SAM and runs them. JPL didn't like this: JPL could not model and simulate it easily (for power thermal etc models). Got through that too.
- Initially had proposed ~9 different analysis scripts. Put those in non-volatile RAM. During cruise, scientists realized those scripts were wrong; never ran one of them. Flexibility of scripting language saved the dat from science POV!
- Have a SAMSIM to estimate resource utilization along with command sequences. Has become pretty high fidelity.

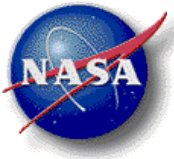

# Tom Nolan

- How are the scripts built?
  - Scientists don't exactly build the scripts, initially scientists loved it, wanted to do that, send to kids in school! Didn't quite work that way. Now have programmers build scripts, because it's hard. Not hard because of BASIC but because SAM is complex to control. Example: 64 valves, must be right! Need to think about valve pressure propagation when you close a valve, for example. Weekly or daily meetings: programmers would write script based on instructions from science team, then there would be a team review of script to peer review it. Still done this way. Innovation that is helpful: have a notion of libraries that can be reused. Example: start high speed vacc pump to evacuate mass spec to  $10^{-6}$  TORR. 100K RPM pump. Hard to get it to run: need to program initial series of signals to get rotor running, then when it can sense it's velocity you can put in auto-control, depends on pressure, etc. Canned this as a subroutine. Great example of 'learning building blocks'.
- Error checking before execution? How is this done? Is it even done? Any tools?
  - There is one automated tool: BASICYY (YACC like). All it does is parse basic script, checks for FSW primitives and libraries, effectively does lex syntax type checks. Still catches errors.
  - Should have done but didn't: centralized constraint handler. SAM has a bunch of 'flight rules'. These are not codified in the software and checked. MOMA instrument designed this way, will run on EXMOARS
  - Wants another entity: Autonomy Manager. Able to do better than simple constraint handling. Could include contingencies, replanners, etc.
- Is any of this info public?
  - Uncertain how much of this is public. There are NASA Tech reports on them. Ask Paul Mahaffy.
  - The SAM HW diagram may be publicly avail somewhere.
  - There is a Curiosity rover science working group. (More about the science than the tech part.)

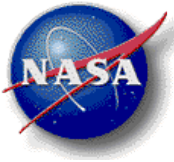

# Florence Tan

- The statement "runs 3 analyzers and much more" does not tell the whole story. eg power control -- Did Tom tell you about how he managed SAM power consumption? If we turned on every heater, we would draw more than 1000 W instantaneously (and blow our fuses). The software controlled the heaters and managed to power to get the pipes up to a target temperature without violating several physical constraints. We also had to perform complex control of each of the analyzers. The GSEs and HW and SW simulators that we had to make to test SAM. And besides SAM Dataview, we also built much rack GSE and Data Display and analysis software (Sam DataView and XINA). It's the whole package and pretty capable. I can talk to you about some of the hardware if you want. Also not sure if experiments are only 3-4 hours, Earlier on, we had ones that ran on Mars for > 9 hours flawlessly.