



# Cryogenic Fuel Valve Testbed Development

Benjamin Freid | University of Colorado, Colorado Springs

Mentors: George Gorospe, Chetan Kulkarni

## CRYOGENIC VALVE TESTBED

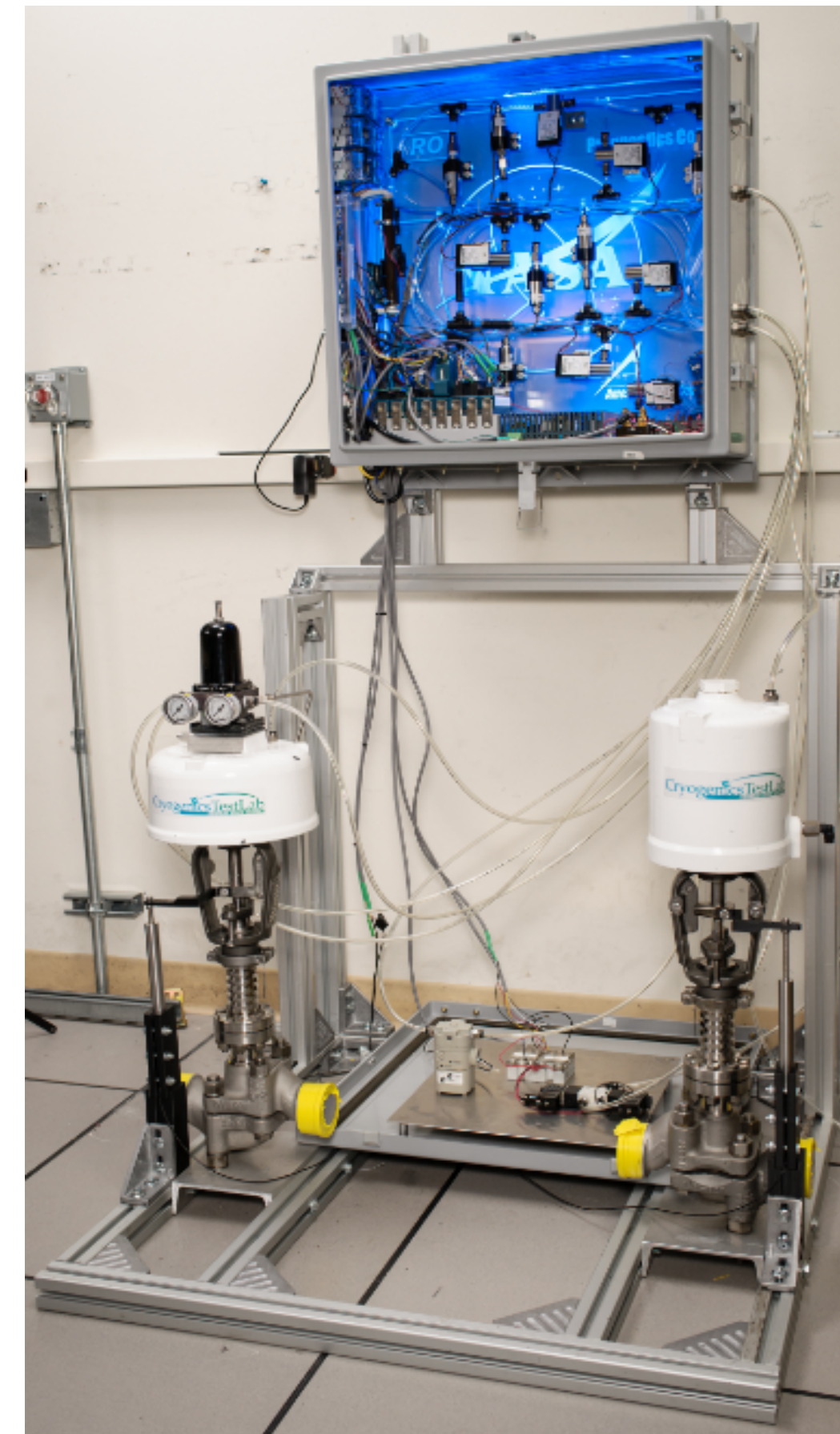

The Cryogenic valve testbed injects controlled faults into the cryogenic fuel valve system in order to accurately determine failure behavior. Data obtained from such experiments is useful for the development of algorithms determining the remaining useful life and end of life for the valves in the fuel loading system. Additionally, the diagnostic and prognostic methods developed with this system can potentially be used for future missions to help manage safety or degradation in a similar system.

## STATE MACHINE

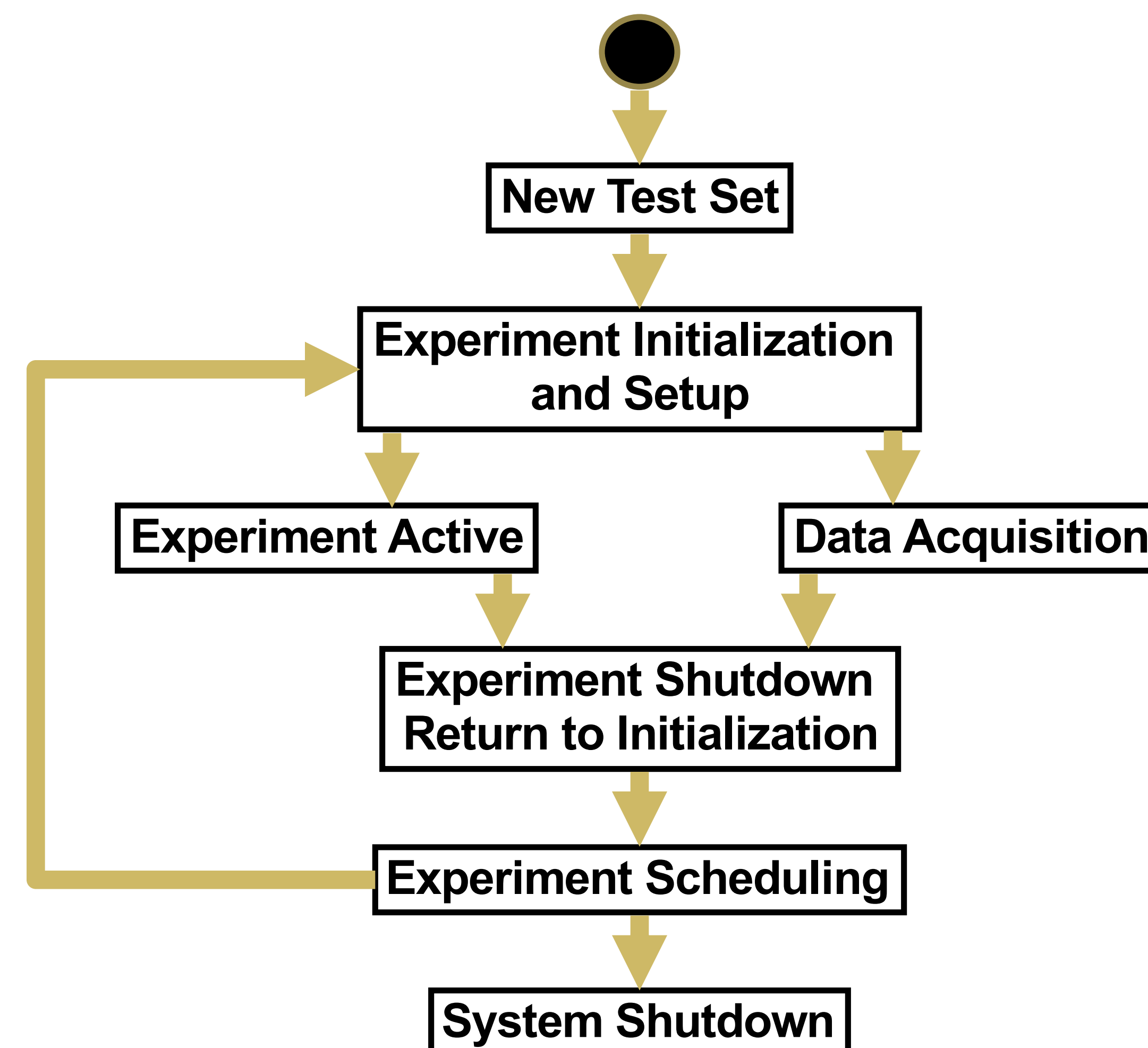

## BACKGROUND

Before a spacecraft can take off, cryogenic liquid Hydrogen and Oxygen must be loaded into the spacecraft's fuel tanks using a pneumatically-actuated valve system. If a valve in the system were to fail during the loading process, then the system's safety can be compromised and the spacecraft could possibly miss its launch window.



To prevent this from happening, diagnostic and prognostic methods may be used to determine the end of life (EOL) and remaining useful life (RUL) of the system. To aid in the creation of these methods, a testbed featuring pneumatic cryogenic valves from NASA Kennedy Space Center was designed and developed at NASA Ames Research Center. This testbed includes hardware to monitor valve performance while injecting faults into the system of valves.

## OBJECTIVE

The goal for this project is to update the cryogenic valve testbed program in LabVIEW to schedule and automate tests and experiments. By using an automated system, tens or hundreds of tests may be performed. This will ensure that accurate data is being collected for testing of the remaining useful life and end of life predictions. From the data obtained, new diagnostic and prognostic methods will be developed to manage or predict potential leaks which may occur in the future.

www.nasa.gov

## OLD BLOCK DIAGRAM

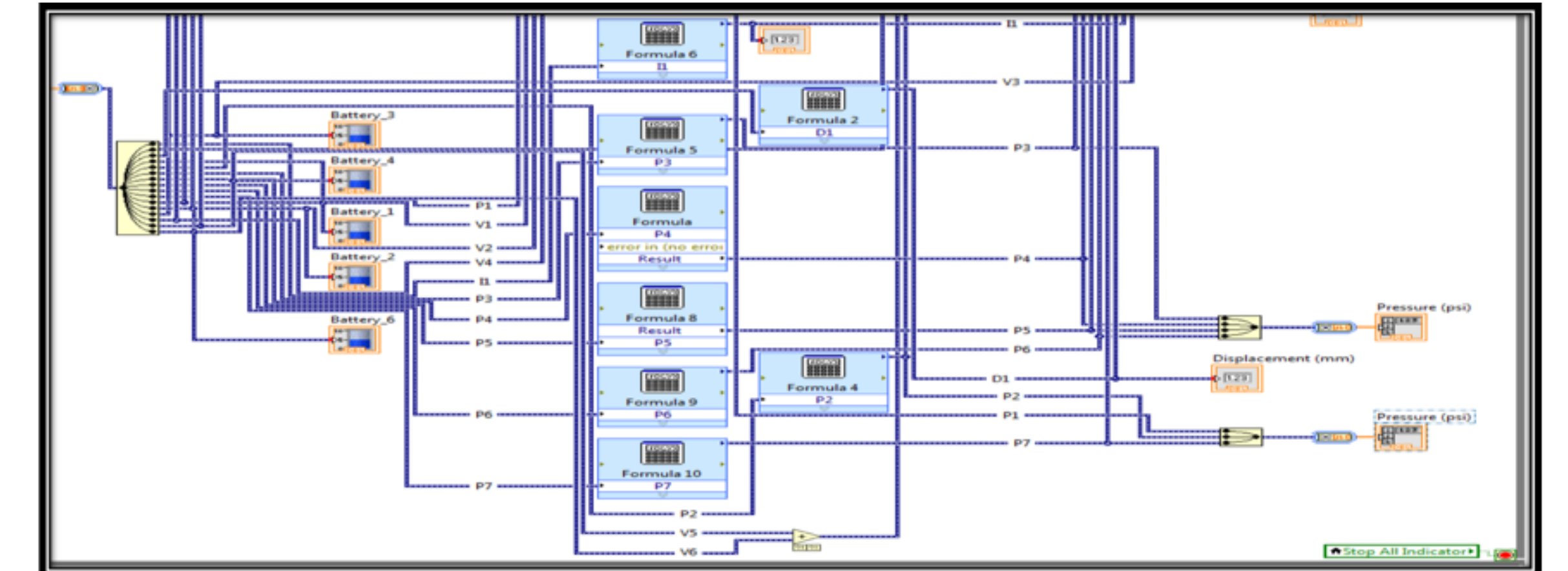

## NEW BLOCK DIAGRAM

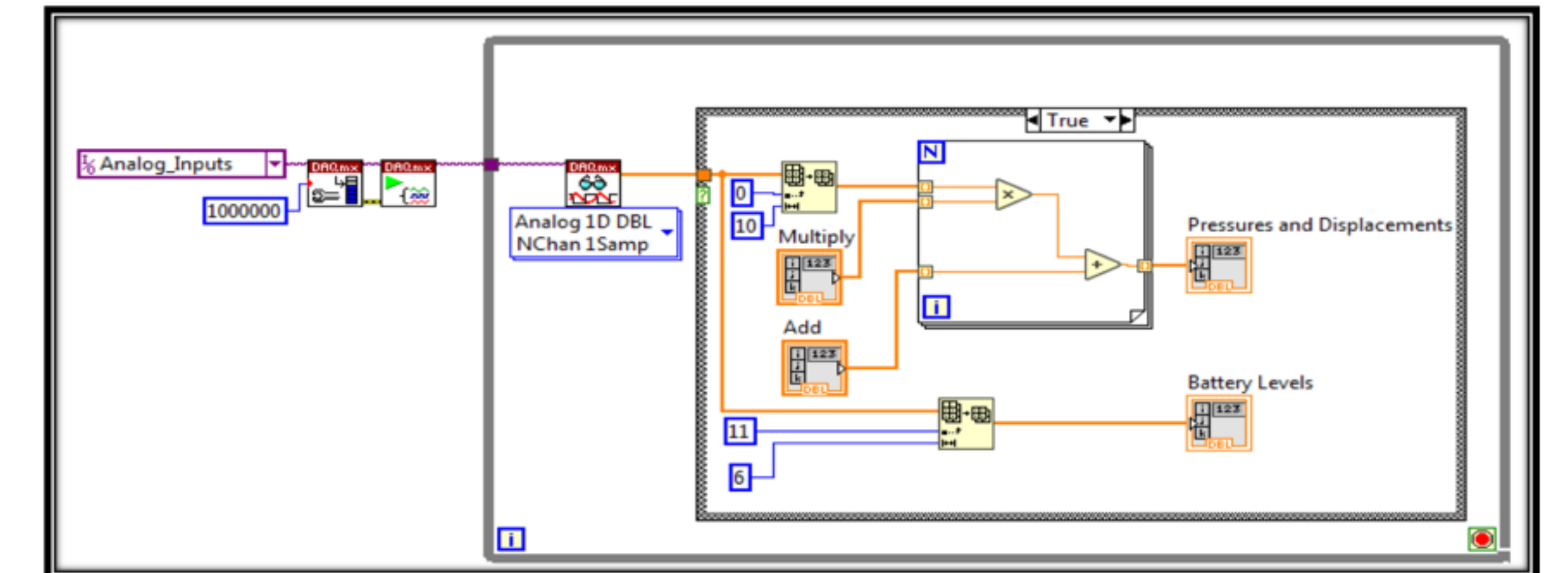

The block diagrams shown above accomplish the same task for the cryogenic fuel valve testbed, by taking in 16 separate inputs, manipulating them, and then storing the data in a location easily accessible to the user. Utilizing a state machine framework in the new block diagram creates an organized, controlled process for data manipulation that is easy to read and easy to debug. Using the state machine framework, the various states can be easily called, allowing for the code to have a large amount of flexibility, without increasing the size of the structure in the diagram.

## ACKNOWLEDGMENTS

I would like to thank my mentors George Gorospe and Chetan Kulkarni for their support and guidance this summer. Their consistent help and mentorship for this project made my experience at NASA unforgettable.



All Photos and figures credited to NASA