

THESIS FOR THE DEGREE OF DOCTOR OF PHILOSOPHY

IN

PRODUCT AND PRODUCTION DEVELOPMENT

CRUSHING PLANT DYNAMICS

GAUTI ASBJÖRNSSON



DEPARTMENT OF PRODUCT AND PRODUCTION DEVELOPMENT

CHALMERS UNIVERSITY OF TECHNOLOGY

GÖTEBORG, SWEDEN

OCTOBER 2015

Crushing Plant Dynamics

Gauti Asbjörnsson

ISBN: 978-91-7597-278-7

Copyright 2015 © Gauti Asbjörnsson

Doktorsavhandlingar vid Chalmers tekniska högskola

Ny serie Nr: 3959

ISSN 0346-718X

Published and distributed by
Chalmers University of Technology
Product and Production Development
SE-412 96 Göteborg

Cover: Conveyor and Stockpile at a Jehander Plant in Kållerød

Printed in Sweden by
Chalmers Reproservice
Göteborg 2015

To Hanna

ABSTRACT

The performance of a crushing plant is an essential element in achieving efficient production of aggregates or metals. A crushing plant's operating performance depends on the design and configuration of each individual process unit, the configuration of the plant, the design of the control system, events occurring in the process and the physical properties of the incoming feed. The production process is a continuous process and as such it is also subjected to variations and changes in performance depending on the condition of the process. Crushing plants however, are traditionally simulated with steady-state simulation models which are not capable of predicting these conditions. A different technique is therefore necessary in order to estimate the actual behaviour of the plant with respect to time.

Crushing plants are affected by both gradual and discrete changes in the process over time which alters the performance of the entire system, making it dynamic. A dynamic simulation is defined in this thesis as continuous simulations with sets of differential equations with static equations to reproduce the dynamic performance of a system.

In this thesis multiple operational issues have been identified in order to achieve adequate process fidelity for simulation purposes. These operational issues have been addressed by introducing methods and models for representing different dynamic aspects of the process. These include: different types of bins to handle misaligned feeding, segregation and different flow behaviour, the use of system identification to measure actuator response to accurately estimate unit response, wear estimation for crushers, mechanistic models for crushers and screens for more accurate estimation of unit dynamics, segmented conveyors that can estimate material flow for conveyors with variable speed drives, parameter selection for optimum process performance, discrete events that occur within the process and different control strategies to capture the process dynamics.

Different applications for dynamic simulation have been explored and demonstrated in this thesis. These include: process evaluation, control development, process optimization, operational planning, maintenance scheduling and operator training. Each of these areas puts different constraints on the modelling of crushing plants and the level of fidelity, which is determined by the purpose of the simulation.

In conclusion, dynamic simulation of production processes has the ability to provide the user with in-depth understanding about the simulated process, details that are usually not available with static simulations. Multiple factors can affect the performance of a crushing plant, factors that need to be included in the simulation to be able to estimate the actual plant performance.

Keywords: Modelling, Dynamic Simulation, Crushing, Screening, Process Optimization, Control, Operator Training, Production Planning

PUBLICATIONS

This thesis contains the following papers.

- Paper A: Asbjörnsson, G., Hulthén, E. and Evertsson, C. M., *Modelling and Dynamic Simulation of Gradual Performance Deterioration of a Crushing Circuit - Including Time Dependence and Wear*, Minerals Engineering (Journal), 2012, Volume 33, pp 13-19.
- Paper B: Asbjörnsson, G., Hulthén, E. and Evertsson, C. M., *Modelling Dynamic Behaviour of Storage Bins for Material Handling in Dynamic Simulations*, Published in the proceedings of the XXVI International Mineral Processing Congress, New Delhi, India, 24-28 September 2012.
- Paper C: Asbjörnsson, G., Hulthén, E. and Evertsson, C. M., *Modelling and Simulation of Dynamic Crushing Plant Behaviour with MATLAB/Simulink*, Minerals Engineering (Journal), 2013, Volume 43-44, pp 112-120.
- Paper D: Hulthén, E., Asbjörnsson, G. and Evertsson, C. M., *Tuning of Real-Time Algorithm for Crushing Plants Using a Dynamic Crushing Plant Simulator*, Published in the proceedings of the 8th International Comminution Symposium, Cape Town, South Africa, 17-20 April 2012.
- Paper E: Asbjörnsson, G., Hulthén, E. and Evertsson, C.M., *An On-line Training Simulator Built on Dynamic Simulations of Crushing Plants*, Published in the proceedings of the 15th IFAC symposium on Control, Optimization and Automation in Mining, Mineral and Metal Processing., San Diego, USA, 25-28 August 2013.
- Paper F: Asbjörnsson, G., Muller, D., Hulthén, E. and Evertsson, C. M., *Implementation of Dynamic Simulation at Anglo Platinum*, Published in the proceedings of the 9th International Comminution Symposium, Cape Town, South Africa, 17-20 April 2014.
- Paper G: Asbjörnsson, G., Hulthén, E. and Evertsson, C. M., *Development of an Operator Training for the Swedish Aggregates Industry*, Published in the proceedings of the 14th European Symposium on Comminution and Classification, Gothenburg, Sweden, 10-12 September 2015.
- Paper H: Asbjörnsson, G., Bengtsson, M., Hulthén, E. and Evertsson, C. M., *Modelling of Discrete Downtime in Continuous Crushing Operation*, Presented at the 5th Computational Modelling, Falmouth, UK, 9-10 June 2015, Submitted to Minerals Engineering (Journal), July 2015.
- Paper I: Asbjörnsson, G., Bengtsson, M., Hulthén, E. and Evertsson, C. M., *Model of Banana Screen for Robust Performance*, Presented at the 4th Physical Separation, Falmouth, UK, 11-12 June 2015, Submitted to Minerals Engineering (Journal), July 2015.

ADDITIONAL PUBLICATIONS

- Paper J: Hulthén, E., Asbjörnsson, G. and Evertsson, C.M., *A Training Simulator for Crushing Plant Operators*, Published in the proceedings of the XXVI International Mineral Processing Congress, New Delhi, India, 24-28 September 2012.
- Paper K: Powell, M.S., Hilden, M.M., Evertsson, C.M., Asbjörnsson, G., Benzer, A.H., Mainza, A.N., Tavares, L.M., Davis, B., Plint, N. and Rule, C., *Optimisation Opportunities for HPGR Circuits*, Published in the proceedings of the 11th AusIMM Mill Operators' Conference 2012, Hobart, Tasmania, 29-31 October 2012.
- Paper L: Asbjörnsson, G., Hulthén, E. and Evertsson, C.M., *Development of a Cognitive Supporting Training Environment*, Published in the proceedings of the XXVII International Mineral Processing Congress, Santiago, Chile, 20-24 October 2014.
- Paper M: Bengtsson, M., Hulthén, E., Asbjörnsson, G. and Evertsson, C.M., *Advanced Material Modelling in Crushing Plants using Real-Time Algorithms*, Presented at the 5th Computational Modelling, Falmouth, UK, 9-10 June 2015.

CONTRIBUTIONS TO CO-AUTHORED PAPERS

In all of the Papers A-I, Asbjörnsson, Evertsson and Hulthén initiated the idea.

Papers A-E & G: Implementation was conducted by Asbjörnsson. Asbjörnsson wrote the paper with Evertsson and Hulthén as reviewers.

Paper D: Implementation of the finite-state machine was conducted by Hulthén. Asbjörnsson provided the simulator and performed the simulations. Hulthén and Asbjörnsson wrote the paper with Evertsson as a reviewer.

Paper F: Implementation was conducted by Asbjörnsson. Asbjörnsson wrote the paper, Muller provided the control algorithm and wrote the control chapter. Evertsson and Hulthén reviewed the paper.

Paper H: Implementation was conducted by Asbjörnsson. Asbjörnsson wrote the paper with Evertsson, Bengtsson, and Hulthén as reviewers.

Paper I: Modelling was conducted equally by Asbjörnsson and Bengtsson, Asbjörnsson performed the sampling and the simulations. Bengtsson wrote the paper with Asbjörnsson, Evertsson and Hulthén as reviewers.

ACKNOWLEDGEMENTS

I would like to start by expressing my gratitude to my supervisors Professor Dr. Magnus Evertsson and Dr. Erik Hulthén, who have given me the opportunity to make this journey. It has been an extraordinary experience and it has been extremely motivating working with both of you.

Thanks to past and present colleagues at Chalmers Rock Processing Systems (CRPS) at the department for Product and Production Development. To Dr. Elisabeth Lee, Dr. Robert Johansson, Johannes Quist, Simon Grunditz, Ali Davoodi, Lorena Guldris Leon, Dr. Magnus Bengtsson, Rebecka Stomvall, Josefine Berntsson and Anton Hjalmarsson, thank you for all the support and advice that you have given me. Without your help I wouldn't have enjoyed this so much.

Without the support from the sponsors this project would never have been possible. Special thanks go to the board of directors at the Ellen, Walter and Lennart Hesselman Foundation for Scientific Research. At MinFo - Swedish Mineral Processing Research Association, I thank Jan Bida. From the Swedish Aggregates Producers Association, SBMI, I thank Björn Strokirk. Thanks to Per Murén at NCC Roads and the Board of Directors at the Swedish Construction Development Foundation (SBUF) and finally to the Board of Directors at the MinBaS II program.

Close collaboration with the industry is essential for any project. Support in the form of data and access to plants has been really important for me. Thanks to the plant personnel and management at the following sites: Jehanders in Fjärås, Kålleröd and Rikssten, NCC in Glimmingen and Stenungssund, especially Pär Johnning, Duane Muller and Niel de Clerk at Anglo Platinum in Johannesburg and Dane Gavin at Anglo Platinum Mogalakwena, to Nick Clarke at Anglo Gold Ashanti to Dr. Aubrey Mainza at University of Cape Town and finally to Kristoffer Hofling, Michael Nordström and Per Lindstedt at Roctim AB.

To everybody that has in some way been involved in this journey, to fellow researchers at Global Comminution Collaboration (GCC), the discussions at conferences and meetings have been a learning experience.

Finally I would like to thank my friends and family for their never ending love and support. Thanks to my mom for giving me curiosity and the capability to enjoying the smaller things in life. Thanks to my Icelandic friends that always treat me like I never left. Thanks to Hanna, for bringing so much laughter into my life.

Gauti Asbjörnsson

Göteborg, October 2015

CONTENTS

Abstract	i
Publications	ii
Additional Publications	iii
Contributions to Co-authored Papers	iv
Acknowledgements	v
1 Introduction	1
1.1 Comminution and Classification Principles	1
1.2 Crushing Plants	3
1.3 Plant Control	4
1.4 Plant Operators	5
1.5 Plant Simulation	5
1.6 Challenges with Crushing Plant Dynamics	6
2 Objectives	7
2.1 Research Outline	7
2.2 Research Questions	8
3 Research Approach	9
3.1 Research Methodology	9
3.2 System Research Approach	11
3.3 Numerical Methods	11
3.4 Research Evaluation	14
4 Literature Review	15
4.1 Comminution	15
4.2 Classification	17
4.3 Steady-State Simulation	18
4.4 Dynamic Simulation	19
4.5 Process Control	20
4.6 Optimization	20
4.7 Operator Training	20
4.8 Factors Influencing Plant Production	21
5 Modelling of Crushing Plants	23
5.1 Modelling Approach	24
5.2 Plant Modelling	25
5.3 Modelling System Dynamics	26
6 Crushing Plant Control	39
6.1 Regulatory Control	39
6.2 Supervisory Control	41
6.3 Control Implementation	42

7	Plant Performance	43
7.1	Process Improvements	43
7.2	User Acceptance Testing	48
7.3	System Stability	49
8	Process Optimization	51
8.1	Control Optimization	51
8.2	Operation Optimization	54
9	Operator Training	57
9.1	System Structure	57
9.2	Usability Study	58
9.3	Operator Evaluation	60
10	Discussion & Conclusions	61
10.1	General	61
10.2	Validation	62
10.3	Answers to Research Questions	63
10.4	Future work	67
	References	69

Appendix

- Paper A: Modelling & Dynamic Simulation of Gradual Performance Deterioration of a Crushing Circuit - Including Time Dependence and Wear
- Paper B: Modelling Dynamic Behaviour of Storage Bins for Material Handling in Dynamic Simulations
- Paper C: Modelling & Simulation of Dynamic Crushing Plant Behaviour with MATLAB/Simulink
- Paper D: Tuning of Real-Time Algorithm for Crushing Plants Using a Dynamic Crushing Plant Simulator
- Paper E: An On-line Training Simulator Built on Dynamic Simulations of Crushing Plants
- Paper F: Implementation of Dynamic Simulation at Anglo Platinum
- Paper G: Development of an Operator Training for the Swedish Aggregates Industry
- Paper H: Modelling of Discrete Downtime in Continuous Crushing Operation
- Paper I: Model of Banana Screen for Robust Performance

NOTATIONS

f_i	Feed size distribution	[-]
p_i	Product size distribution	[-]
γ_i	Material properties	[-]
ρ	Material density	[kg/m ³]
m	Mass	[kg]
\dot{m}	Mass flow	[kg/s]
V	Volume	[m ³]
\dot{V}	Volumetric flow	[m ³ /s]
v	Velocity	[m/s]
t	Time	[s]
α	Angle	[rad]
l_g	Geometric length	[m]
w_g	Geometric width	[m]
h_g	Geometric height	[m]
A	Area	[m ²]
F	Force	[N]
n	Number of sections	[-]
i	Specific section	[-]
u	Input	[-]
y	Output	[-]
x	State variable	[-]
\dot{x}	First order derivative of a state variable	[-]
\hat{x}	State variable estimation	[-]
w	Disturbance	[-]
f	Function	
h	Solver step length	[s]
b_i	Constants	[-]
a_i	Constants	[-]
c_i	Constants	[-]
RQ	Research question	
k	Probability parameter	[-]
λ	Probability parameter	[-]
LTI	Linear time-invariant	
G	Transfer function	[-]
Y	Laplace transform of the input	[-]
U	Laplace transform of the output	[-]
K	Steady-state process gain	[-]
s	Laplace operator	[-]
τ	Time constant	[s]
θ	Time delay	[s]

ξ	Damping coefficient	[-]
x_{max}	Top size of the particle size distribution	[mm]
x_{50}	50 % passing size on the particle size distribution	[mm]
b	Slope of the particle size distribution	[mm]
Q	Capacity	[kg/s]
E	Net specific energy	[kWh/t]
C	Energy material constant	[kWh/t]
b_{ij}	Breakage function	[-]
s	Selection function	[-]
\mathbf{p}	Particle size distribution vector in a crushing zone	[-]
\mathbf{B}	Breakage matrix	[-]
\mathbf{S}	Selection matrix	[-]
\mathbf{I}	Identity matrix	[-]
\mathbf{M}	Mode of breakage	[-]
q	Product quality	[-]
E_i	Screening efficiency	[-]
d_{50}	Cut point	[mm]
h_T	Theoretical opening area of the screen	[mm]
k_j	Passage rate	[1/s]
f_n	Frequency	[Hz]
CSS	Closed side settings	[mm]
ES	Eccentric speed	[rpm]
ET	Eccentric throw	[mm]
e	Error	[-]
PID	Proportional-integral-derivative controller	
K_P	Proportional gain	[-]
K_I	Integral gain	[-]
K_D	Derivative gain	[-]
APC	Advanced process control	
MPC	Model predictive control	
FSM	Finite state machine	
OPC	Object linking and embedding for process control	
SQL	Structured query language	
HMI	Human machine interface	
EA	Evolutionary algorithm	
GA	Genetic algorithm	
g_i	Inequality constraints	
h_i	Equality constraints	
$FIFO$	First in – first out	
$LIFO$	Last in – first out	
$MIMO$	Multiple input – multiple output	
DT	Downtime	[s]
TTF	Time to failure	[s]
WT	Waiting time	[s]
TBC	Time between calibrations	[s]
TTR	Time to repair	[s]
OEE	Overall equipment effectiveness	[-]

1 INTRODUCTION

The aim of this chapter is to:

- *Provide an overview of the process, the control and their operators.*
- *Introduce the simulation technique used in this thesis.*
- *Define the problems with plant simulations today.*

Rock material is one of the largest consumer products of our time. Constructions such as buildings, roads, bridges and railways are almost entirely built out of extracted rock material which has been processed into a usable product, such as aggregates and metals.

Rock occurrence, composition and structure will vary depending on its genesis and the evolutionary formations of the rock [1]. A rock is a collection of minerals that does not have a specific chemical composition. Minerals are however homogenous solids with a specific chemical composition of certain elements or compounds.

Aggregates are granular processed rock materials that has been formed either by nature through erosion or artificially through blasting and crushing. Aggregates have a versatile application spectrum when it comes to construction, traditional use includes: fundamental ingredients in concrete, in the foundation for drainage, around pipes and drains for better pressure distribution and much more [2]. Structural frames and rails are constructed from steel material which is a product of mining, a process in which the metals or minerals in the ore are extracted from the raw material and then used to create a product.

In Sweden, aggregates production is an industry with approximately 1400 active quarries spread throughout the country. In 2013 they produced 76.4 million tonnes of which 63.4 million tonnes were of crushed rock. Most quarries are however relatively small, with 74 % of the plants producing less than 10.000 tonnes annually [3]. Sweden is one of the major mining nations in Europe. In total, nearly 79.1 million tonnes of ore was mined in Sweden in 2013 from only 16 mines. Out of these 79.1 million tonnes, 37.4 million tonnes was from iron ore. The rest consisted of copper, zinc, lead, silver and other metals [4].

1.1 COMMINATION AND CLASSIFICATION PRINCIPLES

Comminution is defined as the process of size reduction of particles [5]. In mining and aggregates production, the size reduction of rock material is achieved in different stages by blasting, crushing and grinding. Comminution of rock is categorised into three different crushing principles: compression, impact and attrition. These principles are described in detail by Evertsson [6] and Lee [7], who denote a more general name instead, form conditioned and energy conditioned crushing.

In form conditioned crushing, the size reduction is performed by a controlled compression of a particle or particles between two surfaces to a certain degree or displacement. Form conditioned

crushing is the working principle in jaw crushers, gyratory crushers, cone crushers, high pressure grinding rolls and vertical roller mills (see Figure 1a). In the case of form conditioned crushing, the amount of size reduction is determined by the relative displacement of the surfaces while the force and energy required for the size reduction are functions of the displacement. This applies for both single particle and interparticle breakage.

In energy conditioned crushing, size reduction is determined by the amount of energy applied to the particles. Energy conditioned crushing is the working principle in vertical shaft impact crushers, impact mills and hammer mills (see Figure 1b). The more energy that is transferred to the particles, the harder the impact is between the particles and a solid steel wall or a bed of particles which subsequently determines the probability of particle breakage.

Attrition is breakage caused by shear failure [6] (Figure 1c), usually as a result of friction between particles, such as in interparticle breakage [7] and in the particle bed in tumbling mills. This friction is caused by the difference in relative motion between the particles which occurs in both form conditioned and energy conditioned crushing. This type of breakage usually generates more fines as small corners on the particle are chipped off in the process.

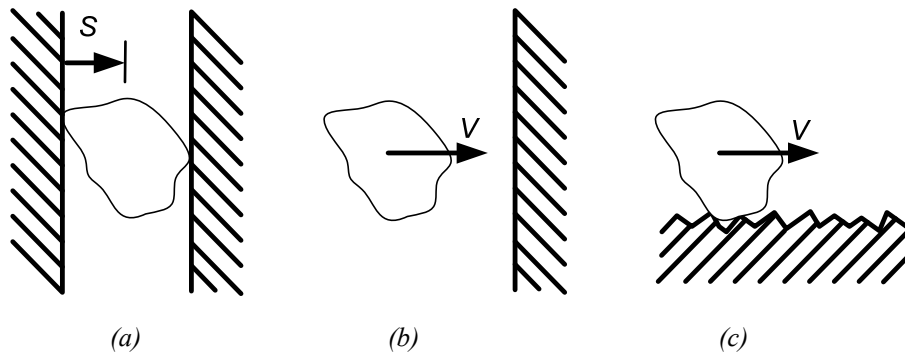

Figure 1. Schematic principles of form conditioned crushing (a), energy conditioned crushing (b) and attrition (c), as presented by Evertsson [6] and Bengtsson [8].

Classification is the process of separating material flows according to specific size, shape or properties. Different techniques can be used to separate the material into separate flows. Usually the technique used is determined by the particle size distribution of the feed. For a coarse material the most common method of separation is screening. The screening media can consist of vibrating steel wire mesh, steel bars, rubber modules or polyurethane modules. The material is transported over the deck due to the inclination and the oscillating motion of the deck. This enables the particles to move in the particle bed and pass through the deck if the particle is smaller than the size of the aperture, see Figure 2a. Particles larger than the aperture will however not pass through and are therefore transported over the deck [9].

For fractions smaller than 2 mm, vibrating screens often become insufficient due to pegging and blinding. In production of manufactured sand [10] and minerals processing [11] it is beneficial to use air-classifiers and hydrocyclones respectively to separate the material below 2 mm. The same principle applies in both units but with different media used; air or water. If the drag force on the particle, which is generated by the flow of the medium, is larger than the gravitational or the centrifugal force the particle will follow the flow. If, on the other hand, the gravitational or the centrifugal force is larger than the drag force, the particle will fall down, as illustrated in Figure 2b. The cut point can therefore be controlled by manipulating the velocity field of the medium [10].

In certain applications it is beneficial to separate particles with respect to their physical properties to increase the concentration of a specific mineral. In minerals processing this can be achieved with gravity separation, magnetic separation, electrostatic separation and flotation for example. In gravity separation the particles' relative difference in density is utilized to separate the particles, similar to cyclones, Figure 2b. In electrostatic and magnetic separation the different levels of attraction to an electrical or a magnetic field are used to separate the valuable mineral from the waste gangue, Figure 2c. In flotation the hydrophobic material is separated from the hydrophilic material by adding reagents and air bubbles to the pulp. The air bubbles will adhere to the hydrophobic mineral surface and travel up to the froth, as illustrated in Figure 2d [5].

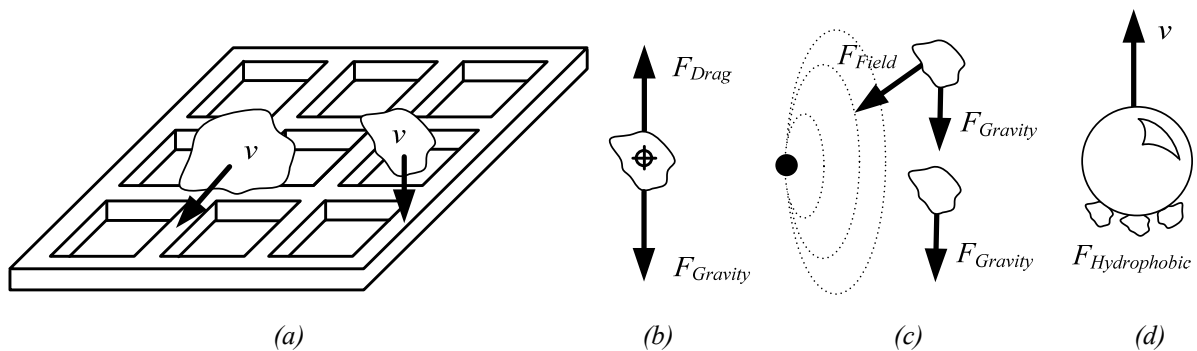

Figure 2. Four methods of separating the material with respect to certain particle size or grade. With a fixed aperture (a), with relative drag force (b), with an electrical or a magnetic field (c) and with hydrophobic properties (d).

1.2 CRUSHING PLANTS

A crushing plant is a configuration of different production units, such as crushers, screens, conveyors, bins, stockpiles and feeders. The number and configuration of units are dependent on the preferred product (Figure 4a) and process performance for which the plant and equipment are designed [12]. This can range from a single crusher with a couple of conveyors to multiple reduction stages in combination with a complex system of bins, screens and conveyors. Figure 3 shows a solution for a three stage crushing plant for an aggregates production application.

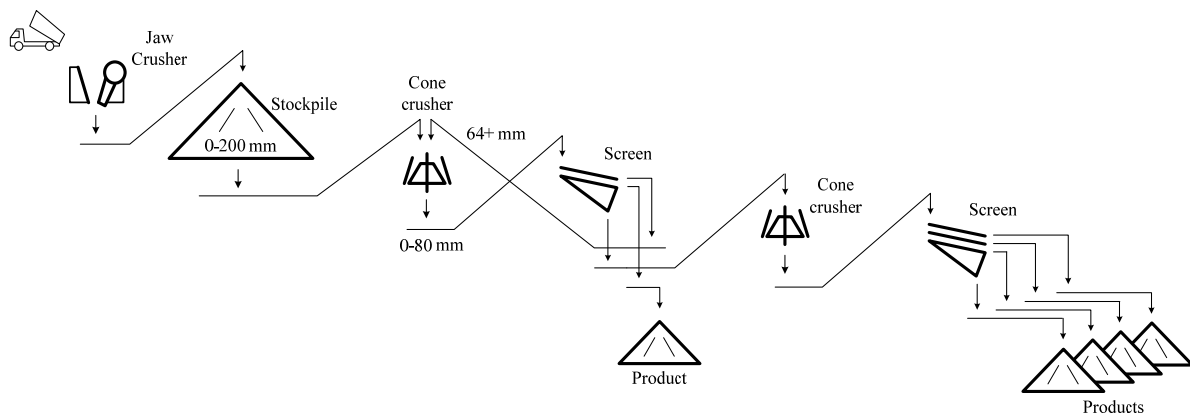

Figure 3. A crushing plant in an aggregates application.

In mining applications, the purpose is to generate fine particles as depicted in Figure 4b. The particles should be fine enough so that the valuable minerals in the ore can be liberated and concentrated [5]. Overgrinding should be avoided. After the dry crushing section, the fine material is fed to mills for further size reduction before being sent to concentration.

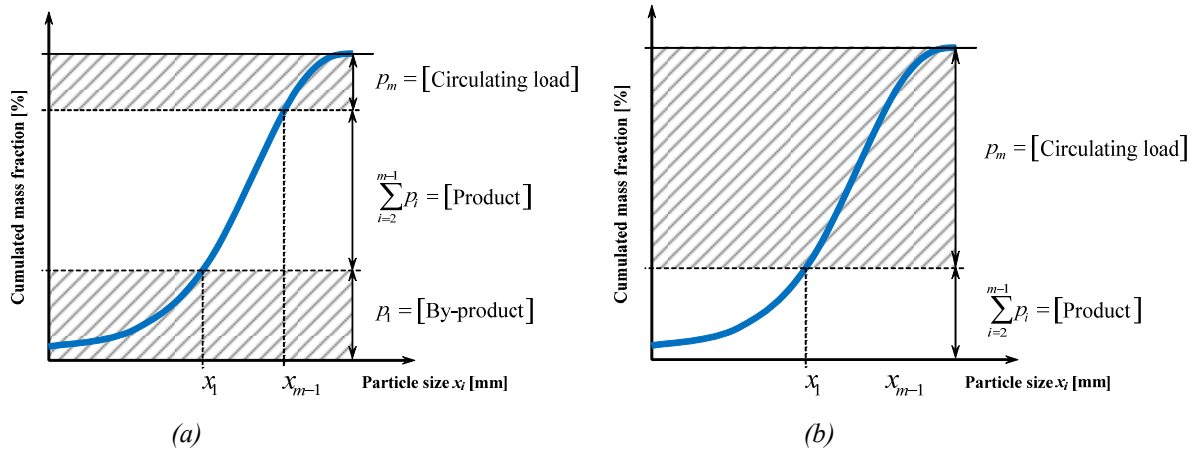

Figure 4. Schematic illustration of product, circulating load and by-product identified on a particle size distribution for aggregates (a) respectively mining application (b), as presented by Lee [7]. The cross-hatched area marks the undesired particle size fractions for both applications.

1.3 PLANT CONTROL

Any modern industrial process that involves mass production with continuous processes, such as mining and aggregates production, uses a high level of automation and process control to ensure safe operation while striving for high product quality and high production throughput. The larger and more complex the production system the higher the demand is on the level of automation. In crushing, the level of automation is relatively limited compared to other process industries, especially for aggregates production.

The control system design of a typical crushing plant consists of regulatory control on actuators, which operate under a supervisory controller, if included. How the controllers operate will depend on the control objectives, system dynamics, selection of control and manipulated variables and the configuration of the controllers [13]. Process units such as feeders are the most commonly controlled actuators in a crushing circuit. They are controlled by altering the frequency of the actuator with interlocks or with a controller which in turn changes the flow rate from the feeder to supply the subsequent part of the circuit with enough material. In Figure 5, a feedback controller with a supervisory controller for controlling either the Closed Side Settings (CSS) or the Eccentric Speed (ES) on a cone crusher is illustrated [12].

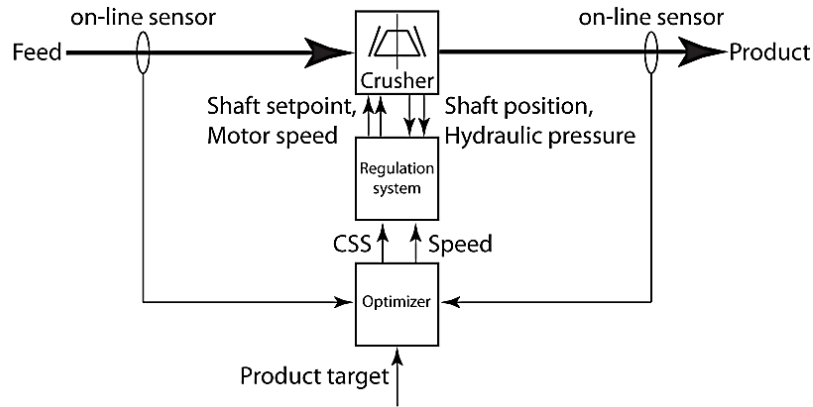

Figure 5. A closed loop process control for controlling the CSS and the ES of a cone crusher, as presented by Hulthén [12].

1.4 PLANT OPERATORS

Operators are responsible for keeping the production running. The level and the type of interaction an operator has with the process is determined by a number of factors such as: the level of automation integrated into the process, the size of the plant, the complexity of the process and the operational management [14]. In a larger plant, with a high number of personnel, an operator's tasks become more specific, such as maintenance, material hauling or process monitoring, whereas in a smaller plant, the operator can be involved in all of the previously mentioned tasks. Many decisions are made by the operators, decisions that rely on the operator's previous experience. Multiple operating decisions, which in many cases could be controlled by the supervisory control system, are left up to manual control. For instance, selecting the operating set points for a cone crusher, i.e. the CSS, is often done by operators, resulting in crusher performance being dependent on the operator's ability to select appropriate operating set points for particular conditions.

1.5 PLANT SIMULATION

Equipment manufacturers as well as plant designers use software packages for predicting plant performance. The most widely used type of simulation technique to date is steady-state simulations, meaning that the system is considered to be in mass balance and consequently all time-derivatives equal zero. By including time dependence and time derivatives it is possible to simulate dynamic behavior. This is referred to as dynamic simulation. Dynamic simulation calculates the performance of the system under different operating conditions as the system experiences changes in state variables over time. Eq. 1.1 illustrates how a system of first order differential equations and output variables y_i are linked to multiple input variables ($u_1(t), \dots, u_m(t)$) and internal state variables ($x_1(t), \dots, x_n(t)$) with respect to time t [15].

$$\begin{aligned} \frac{dx_i(t)}{dt} &= f(x_1(t), \dots, x_n(t), u_1(t), \dots, u_m(t)), \\ y_i(t) &= g(x_1(t), \dots, x_n(t), u_1(t), \dots, u_m(t)) \end{aligned} \quad (1.1)$$

Examples of steady-state simulation packages include: PlantDesigner (Sandvik), MODSIM (Mineral Technologies), Bruno (Metso Minerals), JKSimMet (JKMRC), IES (CRC ORE), Aggflow (BedRock Solution) & UsimPac (Caspeo) [16-19]. Examples of available software that can perform dynamic simulations include: SysCAD (Kenwalt), ProSim (Metso Minerals), Simulink (Mathworks), Aspen Dynamics (Aspentech) and Dymola (Dassault Systèmes), With SysCAD and ProSim currently being the only feasible software with a built-in equipment library for comminution applications.

Plant simulations are usually used for evaluating plant performance, for improving a current design [18, 20] and for operator training. For process evaluation, the steady-state simulation technique is an industry standard with multiple available software that can perform the task. Steady-state simulations are easy to set up and can offer results within a few seconds. Dynamic simulation however, requires more configurations and more calculation time but in return it can give more detailed information about the plant performance under different conditions. Operator training is limited in minerals processing and the focus is mostly directed towards flotation operators. Outotec [21], Met Dynamics (SysCAD) and Rio Tinto Alcan (Honeywell UniSim) [22] offer the possibility of operator training in minerals processing based on dynamic simulations, Met Dynamic is the only one to offer it within comminution [23].

1.6 CHALLENGES WITH CRUSHING PLANT DYNAMICS

Every process is subjected to changes in performance and efficiency over time. Traditional plant simulations are performed with steady-state simulation and are limited to showing only the performance of the system in an ideal situation. However, actual plant performance usually tends to deviate away from the predicted plant performance. These dynamics are usually consequences of an altered state of the plant due to factors such as natural variations, unmatched, inappropriate or degrading equipment performance and stochastic events. These factors can cause considerable reductions in process performance if not attended to.

The applications of steady-state simulation are limited to evaluating plant performance and improving process configuration, while dynamic simulations have a wider application spectrum. Process simulations for aggregates production and mining are especially limited when it comes to the plant operation and control. With steady-state simulations, no considerations are taken with regards to control or operational perspective of the process. This can result in ineffective trial-and-error phases in the actual operation, where operators manually adjust equipment and control settings in order to achieve best possible performance of the system, disregarding or neglecting the change in the system over time.

Control development relies on process understanding. Simulations need to accurately represent the system dynamics under different conditions. Model structure, model validity and simulation purpose are therefore important. Empirical models allow the user to model an existing system while relying on data from the process. When simulating outside the validation space or a non-existing process, mechanistic or semi empirical models are more appropriate. Most process simulations in comminution are based on steady-state assumptions and empirical models.

Operators are responsible for keeping the process running. This involves the operators' capability to detect, analyse and evaluate the process performance and possible solutions. The lack of systematic training is probably the key bottleneck for enhancing the capacity of the human operator when it comes to control needs of the automation system [24]. Dynamic simulations are the foundation for mimicking plant behavior in an operator training system. In operator training the operators interact with simulated what-if process scenarios. These scenarios need to accurately represent the system dynamics in a virtual environment.

2 OBJECTIVES

The aim of this chapter is to:

- *Describe the purpose of the research project.*
- *Formulate the research questions.*

2.1 RESEARCH OUTLINE

Crushing plants, as a continuous process, are affected by gradual and discrete changes in the process that alter the performance of the entire system. The aim of this research is therefore to understand how crushing plants operate under different conditions over time and to develop methods for improving plant performance. Plant performance will include aspects of process throughput, process stability, production yield and product quality. In order to represent the time dependent effects that gradual and discrete changes have on the process, a dynamic simulation modelling platform needs to be developed. A dynamic simulation is defined in this thesis as continuous simulation with sets of differential equations together with static equations to reproduce the dynamic performance of a system.

The objectives of this research are thus to develop dynamic models and a simulation platform for the analysis of dynamic plant behaviour in crushing plants for the purpose of achieving process improvements. This thesis focuses on the plant operation and the performance of the crushing circuit for both aggregates plants and dry comminution processes in mining applications. The area of focus for a mineral processing plant is depicted in Figure 6.

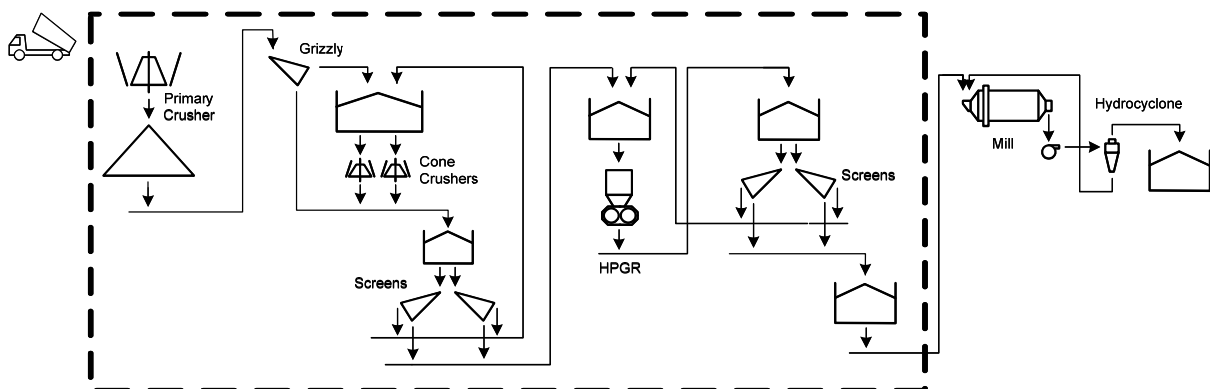

Figure 6. The focus of this research is the crushing and screening stages in aggregates and mining plants, depicted in the dashed box.

2.2 RESEARCH QUESTIONS

The scope of this thesis can be described by the following research questions:

- RQ1. What methods and techniques can be used to satisfactory simulate dynamic crushing plant behaviour?
- RQ2. What physical principles and phenomena can cause dynamic behaviour in crushing plants?
- RQ3. What are the main applications for a dynamic simulation platform?
- RQ4. What process related characteristics must be included in the process model to simulate the process performance and achieve useful information?
- RQ5. How can suitable control strategies for crushing plants be developed with dynamic simulations?
- RQ6. What aspects of using dynamic simulations for operator training should be utilized to improve operators' capability to maintain a safe and productive process?

These research questions will be addressed throughout this thesis and answered at the end of this thesis in Chapter 10 - Discussion & Conclusions. Figure 7 illustrates how the appended papers are relative to each research question and thesis chapters.

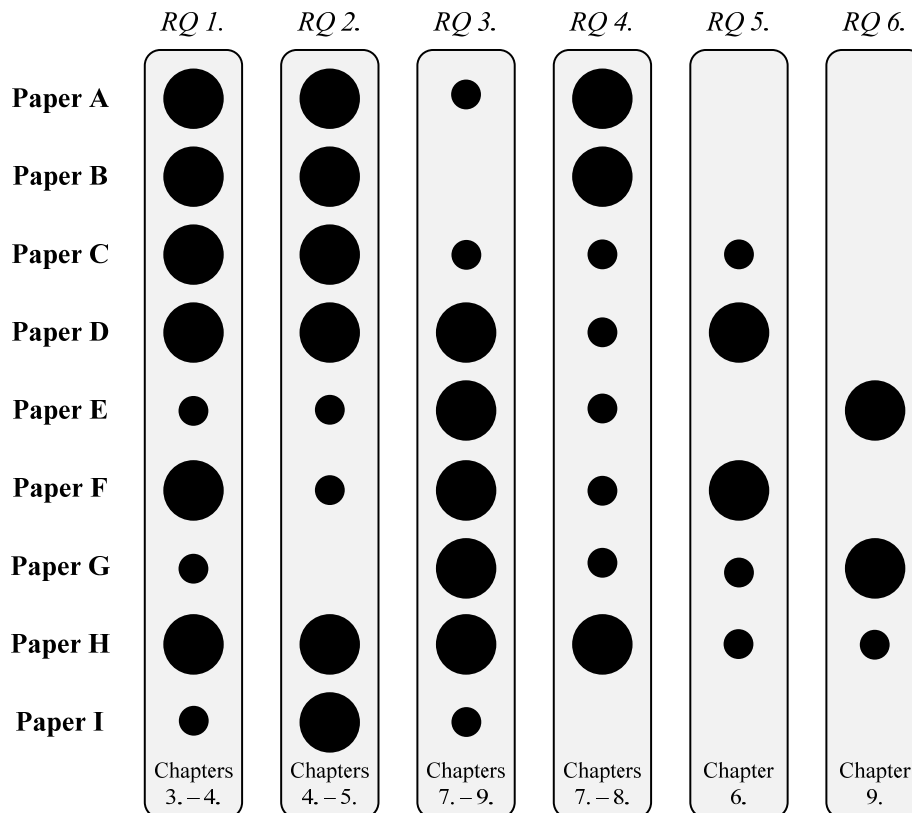

Figure 7. Illustration of how the appended papers are relative to each research question and thesis chapters. Larger sphere represents strong relation to the research question while a smaller sphere represents a weak relation.

3 RESEARCH APPROACH

The aim of this chapter is to:

- *Describe the research approach.*
- *Introduce the research methodology used in this thesis.*
- *Describe the numerical methods used for the dynamic simulations.*
- *Discuss the research evaluation.*

This research was carried out at the Chalmers Rock Processing Systems (CRPS), which is a part of the Machine Element Group at the Department of Product and Production Development at Chalmers University of Technology. The group has been active in research within the field of crushing and screening equipment [6-10, 25], and process performance of crushing circuits [12, 16] for two decades.

3.1 RESEARCH METHODOLOGY

The research approach which has been adopted at Chalmers Rock Processing Systems (CRPS) is characterised as a problem-based approach. The process of problem-based research has been described by Evertsson [6] and Lee [7] and is depicted in Figure 8. In problem-oriented research the choice of methods for solving the problem or question of interest is based on the nature of the problem itself. In other words the problem itself is in the focus rather than the method or tools required to solve it.

Svedensten [16] and Hulthén [12] adopted a different view to the problem-oriented research approach due to the nature of their respective problems. In their opinion, the importance of early implementation was essential for the validity of the results, making it an integrated part of the entire problem-oriented process. According to Crotty [26], each piece of research is unique and calls for a unique methodology. Therefore a general view of problem-based research is described here in detail in order to further show the holistic perspective of the approach.

This work, like other projects at CRPS, was initiated and objectives formulated with regards to an identified industrial problem or a research gap with an industrial relevance. The problem or question in hand is usually an entity in the system which for some reason causes undesirable changes in the process or can be improved to increase the performance of the process or an object.

The first step after the initial problem formulation is to identify the most significant aspect of the problem through both quantitative and qualitative methods such as literature studies, process observations, initial experiments, interviews, on-site data acquisition and data analysis.

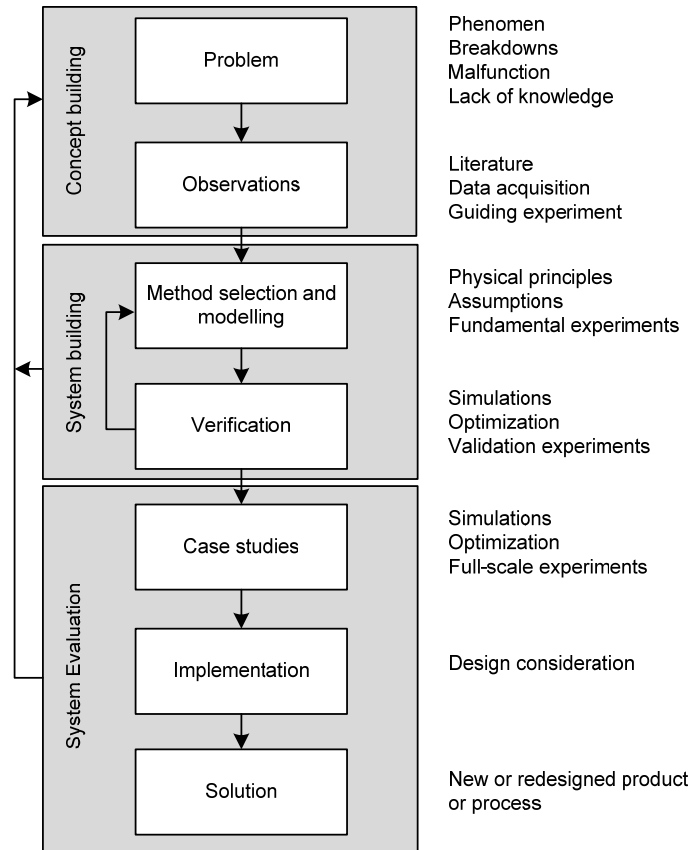

Figure 8. The applied problem-oriented research model slightly modified from Evertsson [6] to account for the system perspective of the research [27].

When the most significant aspect of the problem has been identified the task of method selection and modelling can start. As mentioned earlier, in problem-oriented research the choice of methods for solving the problem or question of interest is based on the nature of the problem itself. An in-depth knowledge of the problem is therefore essential before this phase can be appropriately carried out.

The models are run through a series of simulations and experiments to determine the fidelity of the results. This is an iterative process. If models or methods are not adequate enough the process is repeated with new sets of experiments or possibly new modelling or method selection which improves the representation of the studied object or process. If the models are adequate, larger case studies are performed to further evaluate the models and methods.

How the implementation is conducted is different depending on the characteristics of the problem. Generally the implementation is performed after the iteration process, often as an integrated part of the results from the research as depicted in Figure 8. However, as pointed out by Svedensten [16] and Hulthén [12], an early implementation, during the research phase, is quite important as it will add an additional dimension to the validation process and ensure that the research results are applicable in industry.

CRPS works in close collaboration with the Swedish aggregates and mining industries. By working closely with the industry, problem identification and research implementation becomes more qualitative as relevant challenges that are faced by the industry are studied.

3.2 SYSTEM RESEARCH APPROACH

The performed research is purposely carried out using a holistic system approach, combining different fields in several system levels. Each component in a system comprises of different entities described by sets of principles and attributes. The developed system includes complex aspects of different fields of engineering, technical solutions, human factors and management and their interaction over time [28].

Research using a system approach is by definition a multidisciplinary, iterative process, with a top-down approach to development, synthesis and operation of an actual system. A system fidelity is not determined by individual entities but by the configuration and the relationships between different entities [29, 30]. The performed research is therefore applied and explorative and aims to integrate available knowledge, models and technologies to produce a usable system.

The system approach adds additional iterative dimensions to the problem-based approach. Each study is aimed at specific entity or entities in the system, further defining the problem and increasing the fidelity of the system. The three phases of system development are illustrated in Figure 8 with grey blocks superimposed on the problem-oriented approach.

3.3 NUMERICAL METHODS

In order to approximate the continuous state variables different sets of numerical methods has been applied in this thesis with explicit finite difference approximations. The numerical methods approximate the integral of a system of the differential equation f over a specific time domain t (t_0 to t_n), given an initial condition for the state variables x_i at time t_0 , Eq. 3.1.

$$\frac{dx_i(t)}{dt} = f(x_1(t), \dots, x_n(t), u_1(t), \dots, u_m(t)), \quad t_0 \leq t \leq t_n, \quad x_i(t_0) \text{ given} \quad (3.1)$$

The numerical methods provide finite difference approximations for solving complex calculations of differential equations that cannot be solved analytically. In the Euler method the approximated solution is achieved by the current state variable and its first derivative, Eq. 3.2. The first derivative $f_i(\hat{x}_i(t_n), u_i(t_n))$ is multiplied by the step length h , i.e. the time between each estimation, which is added to the previously computed value for the state variable $\hat{x}_i(t_n)$ to obtain the new state value $\hat{x}_i(t_{n+1})$ over the mesh points that are distributed between t_0 and t_n according to the simulation step size h . This can be illustrated graphically by using Reimann's sums to estimate a definite integral as shown in Figure 9.

$$\hat{x}_i(t_{n+1}) = \hat{x}_i(t_n) + hf_i(\hat{x}_i(t_n), u_i(t_n)), \quad u_i(t_{n+1}) = u_i(t_n) + h \quad (3.2)$$

Improved representations of the Euler method are referred to as Runge-Kutta methods. All orders of the Runge-Kutta methods and their embedded versions address the problem of local truncation error that occurs in the numerical approximation. The local truncation error from the integration will depend on the nonlinearity of the input variable and the step length between each simulation step, i.e. the difference between the input function and the estimation in Figure 9. Decreased step size will result in decreased truncation error at the cost of more computational load [31].

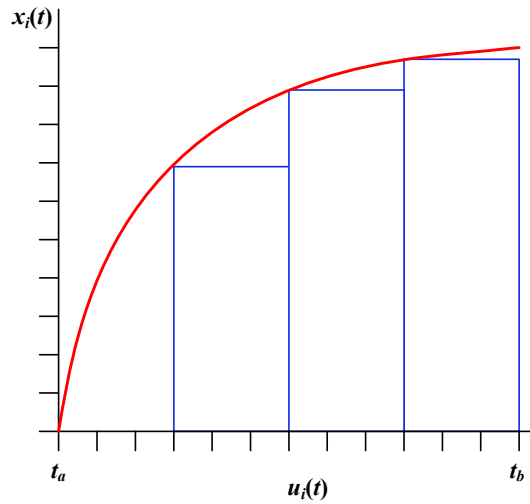

Figure 9. Graphical representation of the Euler method using left Riemann's sums for estimating a definite integral.

In the 2nd order Runge-Kutta method the average time derivative is computed with two points, instead of one as in the Euler method to get a linear approximation between the points. The general form for the 2nd order Runge-Kutta method is shown in Eq. 3.3 and Figure 10. The Heun method is one version of the 2nd order Runge-Kutta method. In the Heun method the value of b_2 is set to 0.5 which determines the value of b_1 , c_1 and a_{21} [32].

$$\hat{x}_i(t_{n+1}) = \hat{x}_i(t_n) + h(b_1k_1 + b_2k_2) \tag{3.3}$$

$$k_1 = f_i(\hat{x}_i(t_n), u_i(t_n))$$

$$k_2 = f_i(\hat{x}_i(t_n) + a_{21}k_1h, u_i(t_n) + c_2h)$$

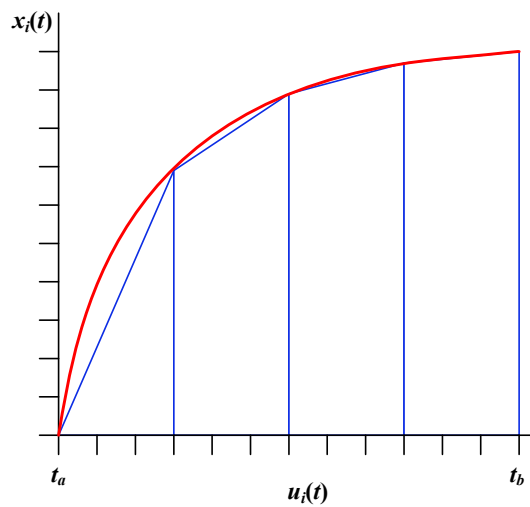

Figure 10. Graphical representation of the Heun method using trapezoids for estimating a definite integral.

Increasing the order of the Runge-Kutta method increases the number of evaluations of the first derivative $f_i(\hat{x}_i(t_n), u_i(t_n))$ per step size and the order of the polynomial approximation for the state variable x_i . In the 2nd order Runge-Kutta method (previously shown) two points were used to estimate a linear estimation of the state variable x_i at t_{n+1} . For a s^{th} order Runge-Kutta, s points per step are used to create a polynomial approximation of the same order, Figure 11 illustrates this principle with the Simpson's rule. Eq.3.4 illustrates the general form of Runge-Kutta method of an order s . Parameters b_i , a_{ij} and c_i define the methods [33].

$$\hat{x}_i(t_{n+1}) = \hat{x}_i(t_n) + h \sum_{j=1}^s b_j k_j \quad (3.4)$$

$$k_1 = f_i(\hat{x}_i(t_n), u_i(t_n))$$

$$k_i = f_i(\hat{x}_i(t_n) + \sum_{j=1}^{i-1} a_{ij} k_j, u_i(t_n) + c_i h)$$

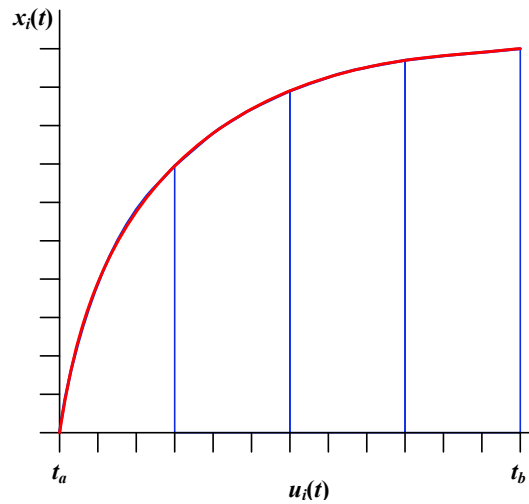

Figure 11. Graphical representation of the Runge-Kutta method by using Simpson's rule for estimating a definite integral.

Increasing the order of the solver will not only increase the accuracy of the numerical estimation, i.e. reduce the truncation error, but also increase the computational load since more points are evaluated during each step size.

Two dynamic simulation platforms have been used during this thesis. In Paper A the Kenwalt's software SysCAD was used to benchmark the leading commercial dynamic simulation platform for comminution, while in Papers B-I Mathwork's software Simulink was used. The 2nd order Runge-Kutta method was used in Paper A and H, while in Papers B-G and I the 3rd order Runge-Kutta method was used.

3.4 RESEARCH EVALUATION

The most recurring criteria for evaluating research is validity. Validity concerns the integrity of the conclusions that are generated from the conducted research [34]. Validation of the research is the process of determining the degree of fidelity of the system from the perspective of its intended purpose [35].

In Pedersen et al. [36] the research validation is described as structural validity and performance validity, from both theoretical and empirical perspective. Structural validity refers to the system's background information which is the foundation for the constructed system and the appropriateness of the selected examples to illustrate the problem. The performance validity states that the system produces satisfactory accuracy and that the results are useful and consistent within its domain of application.

Quist [37] describes his approach to theoretical structure validity by applying pragmatic congruence of a system where the modelled system is defined to have either weak or strong congruence to the observed system [38]. By comparing the estimated output with the observed value a quantitative evaluation of the theoretical structure validity in parameter selection and configuration is achieved.

Another important issue is the generalization of the system or external validation [34]. Can the knowledge and the results from this thesis be extrapolated from the particular context in which the research was performed?

These different aspects of research evaluation will be discussed in Chapter 10 – Discussion & Conclusions.

4 LITERATURE REVIEW

The aim of this chapter is to:

- *Provide an introduction to the modelling of comminution and classification circuits.*
- *Describe research that has focused on process simulation of crushing plants.*
- *Describe the recent research on control, optimization and operator training*
- *Describe the research on factors that influence plant performance.*

The research done on crushing plant simulation is diverse. The focus is mainly concentrated on single production units and steady-state simulations of process plants. Less focus is given to the interaction between different units, the operation of the plant and process controls. This seems to be the tradition in both the mining and the aggregates industry.

4.1 COMMUNITION

The essential parts of any crushing plant are the size reduction and size separation processes. The classical comminution theories, which were derived by Rittinger [39], Kick [40] and Bond [41] respectively, aim to describe the relation between comminution energy and size reduction for a given feed size. These three theories, are usually referred to as the first, second and third theory of comminution. These theories provided an estimation of product particle size from empirical testing for crushing and grinding. A significant drawback of these theories is however that they only rely on a single point on the particle size distribution curve as pointed out by Lindqvist [42], namely f_{80} and p_{80} . This is not enough to characterize the whole particle size distribution curve and can only provide a rough estimation of the breakage behaviour in comminution equipment. Walker et al. [43] and later Hukki [44] pointed out a more general form of the relation between comminution energy dE , size reduction dx and particle size x^n in Eq. 4.1. The energy is directly proportional to the size reduction but inversely proportional to particles size x depending on material energy constant C .

$$dE = -C \frac{dx}{x^n} \quad (4.1)$$

The most common mathematical model used today for expressing the comminution of particles is the population balance model, first introduced by Epstein, [45] Eq. 4.2.

$$f_i + \sum_{j=1}^{i-1} b_{ij} s_j m_j = p_i + s_i m_i \quad (4.2)$$

The population balance model is a mass balance equation which aims to describe the conservation of mass within a system and the transformation of material feed f_i to material product p_i . The transformation is based on the probability of particle selection s_i and particle breakage b_{ij} under a given system condition m_i [18].

The simplicity of the equation has made it popular when it comes to model size reduction in comminution equipment. Multiple researchers have applied the population balance model in different forms to express the probability of selection/breakage behaviour within specific units, such as: cone crushers [46], high pressure grinding rolls [47], ball mills [48], autogenous and semi autogenous mills [49].

Adjusting the population balance model to take into consideration the time derivative of mill content $m_i(t)$ was done by Valery, Eq. 4.3, [50]. Valery proposed dynamic models for mill ball charge, rock charge, water charge and mill liner weight as a function of feed rate, feed size, feed hardness, speed and water addition which in turn affects the power draw, grinding charge level, slurry level and product size distribution.

$$\frac{dm_i(t)}{dt} = f_i - p_i + \sum_{j=1}^{i-1} b_{ij}s_jm_j - s_i m_i \quad (4.3)$$

The applications of the population balance model are generally empirical and rely on extensive databases. There are however cases where a mechanistic modelling approach has been applied to estimate the generated collision energy within a constrained system [51].

In modelling of cone crushers there are two dominating modelling approaches: empirical modelling [46] and mechanistic modelling. A mechanistic model is a detailed analytical model based on the Newtonian mechanics [52] of the unit. A mechanistic model of a crusher has been proposed by Evertsson [6] and applied in Paper H. Empirical approximations were used in Papers A-G. These mechanistic models provide more accurate information since they take into consideration the crusher geometry and the repeated compressive crushing that occurs within the crushing chamber, see Eq. 4.4. The crusher model requires however, more detailed information about the crusher, such as geometry and form condition breakage behaviour. These models are however computational heavy and need a considerable amount of simulation time.

$$\mathbf{p}_i = \left[\left[\mathbf{B}_i^{\text{inter}} \mathbf{S}_i + (\mathbf{I} - \mathbf{S}_i) \right] \mathbf{M}_i^{\text{inter}} + \mathbf{B}_i^{\text{single}} \mathbf{M}_i^{\text{single}} \right] \mathbf{p}_{i-1} \quad (4.4)$$

Parameter \mathbf{p}_i represents the product size distribution from crushing zone i and \mathbf{p}_{i-1} corresponds to the product from the previous crushing zone ($i-1$) and the feed to zone i . Furthermore, \mathbf{B}_i and \mathbf{S}_i represent the breakage and selection matrix operators, respectively. \mathbf{I} is an Identity matrix and the mode of breakage for each zone i is represented with the \mathbf{M}_i matrix operator for both single particle and interparticle breakage.

Apart from the breakage behaviour, Evertsson also predicted crusher power draw [53], crushing pressure [53] and capacity [6]. The crusher capacity Q was formulated as an integral function with the bulk density of the material ρ in each compression zone, utility factor η , the velocity vector v of the particles during one revolution at the choke point in the crusher between the mantle radius R_i and the concave radius R_o over the angle α , see Eq. 4.5.

$$Q_{\max} = \int_0^{\alpha_c} \int_{R_i(\alpha)}^{R_o} \rho(\alpha) v(\alpha) r dr d\alpha - \frac{1}{2} (\eta_{v,choke} \rho (R_o^2 - R_{i,\alpha_c}^2)) \int_0^{\alpha_c} v(\alpha) d\alpha \quad (4.5)$$

In Sbárbaro [54] the volume accumulation was described with the standard mass balance equation in Eq. 4.6. Parameters \dot{m}_{in} and \dot{m}_{out} represent the mass flow in and out of the system while $dm(t)/dt$ represent the rate of change of mass within the system. However, since the crusher hopper has a complex geometry the correlation between accumulated volume and level is nonlinear.

$$\frac{dm(t)}{dt} = \dot{m}_{in}(t) - \dot{m}_{out}(t) \quad (4.6)$$

4.2 CLASSIFICATION

Classification divides the mass flow according to specific size fractions, shape or properties. Classification is traditionally simulated with quite simple mathematical models. The most common approach is the phenomenological efficiency curve first introduced by Reid and Plitt [55, 56], see Eq. 4.7 and used in Papers A-H. The Reid-Plitt efficiency curve is based on the continuous probabilistic distribution proposed by Rosin-Rammler [57].

$$E_i = 1 - e^{(-\ln 2(x_i)^{5.846})} \quad (4.7)$$

The efficiency E_i is the weight fraction of a size range that is carried over to the oversize screening product x_i which is the relation between the cut point and the selected size fraction. The parameter m is the sharpness of the separation. Other forms of representing the efficiency of the separation are with the exponential sum expression derived by Whiten [46], in Eq. 4.8, and the polynomial function derived by Hatch and Mular [58]. Parameter α represents the sharpness of the cut and x_i is the relation between the cut point and the selected size fraction.

$$E_i = \left(\frac{e^{(\lambda x_i)} - 1}{e^{(\lambda x_i)} - e^{(\lambda)} - 2} \right) \quad (4.8)$$

Estimation of the cut point d_{50} can be achieved with the model proposed by Karra [59] with Eq. 4.9. The cut point is determined by a number of independent factors $A-G$ (correspond to the operation and configuration of the screen), the theoretical open area h_T , the surface area of the screen A_{screen} and the theoretical amount of material \dot{m}_{us} below the aperture in the feed.

$$d_{50} = \alpha h_T \left(\frac{\dot{m}_{us} / A_{screen}}{ABCDEFG} \right) \quad (4.9)$$

A more detailed analytical model based on the Newtonian mechanics [52] of vibrating screens has been proposed by Soldinger Staffhammar [9] and applied in Paper I. The mass flow is described by introducing layers in a segmented environment based on discrete step time Δt . The particles move through the bed (\dot{m}_{i+1} , \dot{m}_i , \dot{m}_{up} and \dot{m}_{down}) by stratification due to the inclination and the oscillating motion of the deck, see Eq. 4.10. If a particle is within a given size fraction that is smaller than the aperture and it is in the contact layer, the probability of the particle to pass through the deck is determined by the mass flow of particles in the contact layer (\dot{m}_{BP}) and by a passage rate parameter k_j .

$$\dot{m}_{i+1,j,n_i} = \dot{m}_{i,j,n_i} + \dot{m}_{down,i,j,n_i-1} - \dot{m}_{up,i,j,n_i} - \dot{m}_{BP,i,j} k_j \Delta t \quad (4.10)$$

4.3 STEADY-STATE SIMULATION

Research on numerical crushing plant simulations has been conducted since the 1970's, by researchers such as Lynch [60] and Whiten [46] (JKSimMet at JKMRC), King [19] (MODSIM at University of Utah) and Svedensten [16] (PlantDesigner at Chalmers University of Technology). These software, as well as Bruno (Metso Minerals), IES (CRC Ore) and Aggflow (BedRock Software LLC), are all steady-state simulations packages which are industrial standards for evaluating plant performance in both the aggregates and the mining industry.

According to Morrison and Richardson [20] there are three main application areas for steady-state process simulations:

- Data analysis
- Plant optimization
- Plant design

Data analysis of survey data with steady-state simulations is achieved by mass balancing and model fitting to obtain a best estimation with data redundancy from survey data [18]. This is necessary since equipment will exhibit different performance and load conditions during an operation and survey data only provides a snapshot of the process at a particular place and at a particular time.

Steady-state simulations have been used with great success for plant analyses and optimization [16, 61]. However, these simulators lack a certain perspective of the operation, namely, changes in the system over time and the performance at non-ideal operating conditions.

Steady-state process simulations are often used to evaluate and compare different circuit configurations and design [62]. Relying on steady-state simulation alone can however cause considerable operational issues. Steady-state simulations do not take into consideration material handling, regulatory or supervisory controllers and maintenance strategies which will have associated operating and maintenance issues throughout the circuit [63].

4.4 DYNAMIC SIMULATION

A commonly used platform for dynamic simulation is Simulink which is developed by Mathworks. However, other commercial software packages are available such as SysCAD and ProSim, as previously mentioned.

Whiten [64] was one of the first to discuss the necessary transition steps from steady-state models to dynamic models. The initial points only included: short constant residence time in production units, constant delay in conveyors and a variable delay time for material flow based on the last in – first out principle (LIFO). Additionally, it was enough to represent the particle size distribution with only five fractions.

The initial attempts to add dynamic perspective to steady-state simulation of crushing was done by Herbst and Oblad [65]. This was done by estimating discrete crushing zones in a cone crusher and with a static estimation of product size distribution as a function of mass flow, power, level in the crusher and feed size distribution. Disturbances were imposed on the circuit by altering feed rate, particle size distribution and ore hardness.

In the work by Sbárbaro [66], empirical models were used and modified to give the processing plant a dynamic response. This is done by including accumulation of mass, time delay and simple mixing models to enable model-based control system design. Sbárbaro states that even though mechanistic models are able to provide a detail estimation of the factors affecting the unit, the empirical models are more feasible since they provide a reasonable compromise between representability and simplicity. However, no consideration was given to dynamic response of the actuators, gradual changes due to wear or discrete events.

Similar to Sbárbaro, Liu et al. [67], adds accumulation of mass, time delay and mixing models to empirical models. The focus is on a grinding circuit to visualize the possibilities of using dynamic simulation. The mill is assumed to have a constant residence time and three perfect mixers in series. The equipment used in this study only includes a mill and a hydrocyclone where even the model for the hydrocyclone does not include any dynamics, thus limiting the general purpose use of the model.

In Itävuo's work [68] the base for the dynamic modelling is the mechanistic crusher model developed by Evertsson [6], with the addition of the effects from material properties studied by Ruuskanen [69]. Itävuo estimates the response of the actuators under different conditions to be able to estimate the actual response of the crusher when discrete changes are initiated such as changing the CSS. These simulations are computational heavy making the simulation time long and not suitable for all purposes, however these simulations are able to supply qualitative information about the process response and are therefore well suited to the development of a control system.

4.5 PROCESS CONTROL

Due to the nature of dynamic simulations the material stockpiles, bins and flows need to be controlled. In crushing plants, different types of regulatory and supervisory control loops are used to ensure safe operation while striving for high product quality and high production throughput.

Large majority of industrial controllers are regulatory Proportional-Integral-Derivative (PID) controllers and as high as 90-95 % of industrial controls are PID based [70, 71]. However, the derivative term is usually not included [71], resulting in a PI controller.

In recent years a large focus has been on different applications of feedback controllers in different crushing circuit configurations. These include: traditional PID approach [68, 70], ratio control [70, 72, 73], limiting controllers [54, 70], MIMO-PI controller [71], cascade controllers [71], mass balance method [71], linear quadratic regulators [74] and predictive PI controllers [70, 71]. All in order to improve the controllers' capability to reject disturbances and keep a stable process.

Supervisory controllers have been proposed to optimize the production in real time. On-line optimization has been done by Hulthén [12] by using a Finite State Machine (FSM) and an evolutionary operation approach as a supervisory controllers to identify optimum process parameters on-line. Atta has also demonstrated the possibility of using an Extremum seeking control to locate optimum configuration of the ES and CSS in a cone crusher [75].

4.6 OPTIMIZATION

An Evolutionary Algorithm (EA) has been used both for optimization of crushing circuits [16, 76] and crushing equipment [7, 77] successfully. The selection of Genetic Algorithm (GA) is best motivated by the algorithm capability to handle nonlinear complex problems and discrete variables [16, 78]. The drawback with the GA is the relatively long computational time compared to other optimization algorithms due to its stochastic approach and the risk of locating only local minimum.

Within the context of minerals processing research the term optimization is sometimes used instead of process improvements. In Napier-Munn et al. [18] an iterative manual method is described where the parameters are selected by inductive reasoning. Even if the method shows a potential for process improvements it is no guarantee that it is the process optimum. A systematic approach to process improvements through process surveys is to perform an experimental design. An experimental design provides an efficient way to improve the validation domain of the sample and obtain process improvements by studying the response surface from individual factors and their interactions [79].

4.7 OPERATOR TRAINING

The operators are an essential part of the process but are often overlooked [80]. Even though a major part of the process is controlled by automation the operators still interact with the process on different levels.

In Li et al. [24] the limitations regarding Human-Machine-Interfaces (HMI) are described using a simplified human supervisory model. The model consists of four different phases of human interaction with displays: detection, analysis, action and evaluation. In this study the authors identified several limitations when it comes to operator interaction with the process, one of

them being the operator training. Li states that the lack of systematic training is probably the key bottleneck for enhancing the capacity of the human operator when it comes to control needs of the automation system.

Operator training allows the operator to interact with the simulated process in real time through a HMI. In the recent work of Toro et al. [81, 82] online applications were developed to allow the operators to log on, run predefined scenarios and score points with regards to the performance of the circuit. In both cases a limited part of the circuit was simulated.

4.8 FACTORS INFLUENCING PLANT PRODUCTION

Every production process experiences dynamic behavior as a result of internal and external disturbances. The process can be sensitive to wear, size segregation of the material, natural variations and more.

Wear on equipment and components in comminution circuits is extensive due to the physical nature of the crushing process and the abrasiveness of the rock material. It will have different effects on the process depending on the production unit and rock material. The study of wear in comminution is a reoccurring subject both due to the fact that it affects the production [12, 25, 83] and because of the environmental impact [84]. The wear in compressive crushers, such as gyratory and cone crushers, is typically categorized as only abrasive [25], this causes changes in the liner profiles and in turn affects the crusher's performance. The amount of wear in a cone crusher depends on a number of factors such as material properties [65], particle size distribution [25] and moisture [85]. Bearman and Briggs stated that time dependency in a cone crusher is an important issue and dramatic reductions in performance can occur in a passive operating environment. An active environment includes matching the crusher control strategies, liners design and different operational strategies to the operating conditions and the product requirements [86].

Research on wear on screening media is not as comprehensive as the wear in crushers and mills but as pointed out by Svedensten [16], wear on screens does cause larger aperture on the deck and therefore alters the particle size distribution of the screened product. This is a large problem when considering quality of the aggregates production where production of a particular particle size is important because of quality requirements [87].

Segregation and inadequate material handling can reduce plant performance and product quality. In Powell et al. [88], several problems are identified that are considered to be a direct consequence of segregation and inadequate material handling in a dry crushing section in a mining application. If not attended to, these problems can cause reduced plant performance and could even cause premature equipment failure. Factors such as lower product quality, uneven wear, high stress amplitudes and premature equipment failure are considered as consequences of segregation and misalignment of crusher feed [89, 90].

Non-linear process behaviour is a part of the actual process. Hoppers and bins can have irregular geometries and even dead volumes which will affect how the mass flows and feeders' response will vary depending on their type and size. In Itävuo et al. [71] the non-linear and asymmetrical behaviour of a vibrating feeder was illustrated, Figure 12. Additional nonlinear performance will occur during overloading of screens [88] and from misaligned and non-choked conditions in crushers [89].

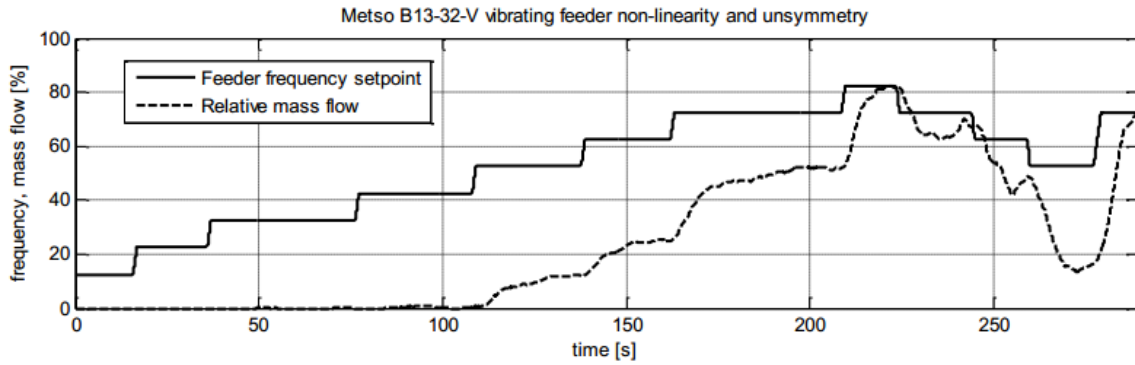

Figure 12. Non-linear response of a vibrating feeder [71].

One of the challenges in plant simulation is the estimation of natural variations. Variations occur everywhere, both in the production units and in the rock material itself [91]. Continuous monitoring, such as mass flow meters [12] and image analyses of particle size distribution [92] can provide helpful information about the process variations but certain information can still only be gathered by manual sampling from the process (material properties and often particle size distribution). This is not ideal as the samples are small compared to the amount of processed material and only reflect a momentary state at a certain part of the process.

Several factors that affect equipment performance with specific focus on cone crushers have been discussed from a holistic perspective by Evertsson [6] and from a time dependent perspective by Bearman and Briggs [86]. The effect of varying feed by, for example, feed grading, crushability, moisture content and more has been described in detail by Ruuskanen [69] but most of the data has been gathered when studying one factor at a time, therefore not taking into consideration the possible effects of interaction.

5 MODELLING OF CRUSHING PLANTS

The aim of this chapter is to:

- *Introduce the characteristics of dynamic modelling.*
- *Explain the modelling approach adopted in this thesis.*
- *Present the different elements needed for dynamic modelling of crushing plants.*

Modelling and simulation of industrial processes, such as crushing plants, provides an insight into the internals of the process which would be difficult to obtain otherwise. However, the modelling process is a complex task involving different systems that requires different modelling techniques depending on the characteristics of the problem.

In general, dynamic plant simulations include a number of different factors which affect the dynamic performance of the system. The process can be sensitive to startups, discrete events, wear, segregation, natural variations and other factors that commonly occur during operation. All depending on interaction between single production units, plant configuration, plant control loops and diverse events and disturbances that can influence the process, see Figure 13.

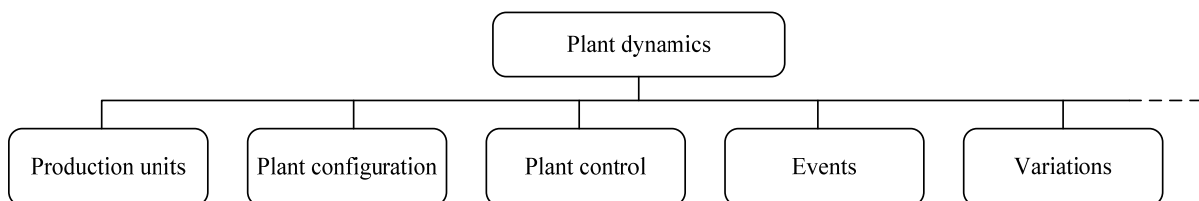

Figure 13. Plant dynamics can originate from different sources in the process operation.

Changes and variations occur everywhere in the process and can be either discrete or gradual. Figure 14 illustrates factors that can affect the total performance of the plant in one way or another, ranging from different settings of a single production unit to unavoidable consequences of the process such as wear and segregation. How these elements affect the process is dependent on multiple factors involving both the rock material itself and the utilized production units.

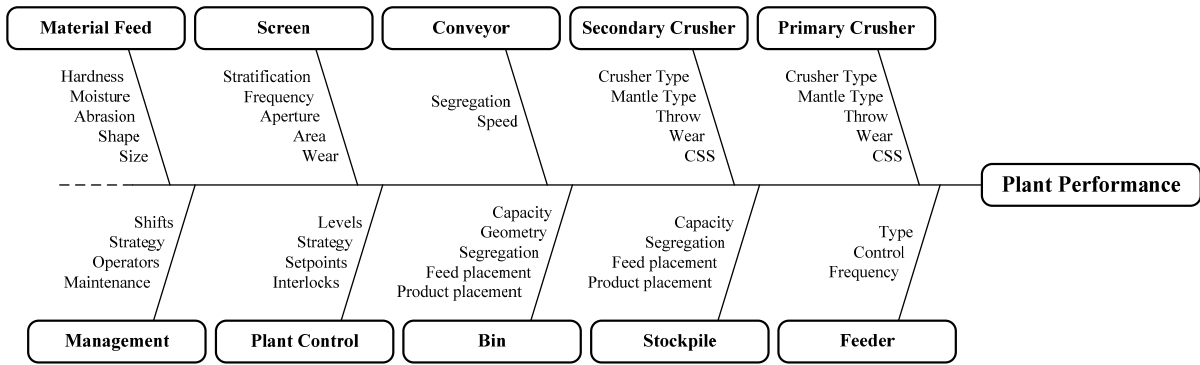

Figure 14. Cause-and-effect diagram over factors that can influence plant performance.

5.1 MODELLING APPROACH

A system approach was adopted for the modelling work in this thesis. With a system approach the modelling is done with a top down design perspective. In other words, the system is divided into smaller subsystems or models, denoted by the equipment level. Each subsystem can be further divided into smaller modules to represent the functional or fundamental level of a particular subsystem. Each subsystem is built as an individual model and can therefore be handled separately. Figure 15 illustrates the hierarchal structure of the modelled system.

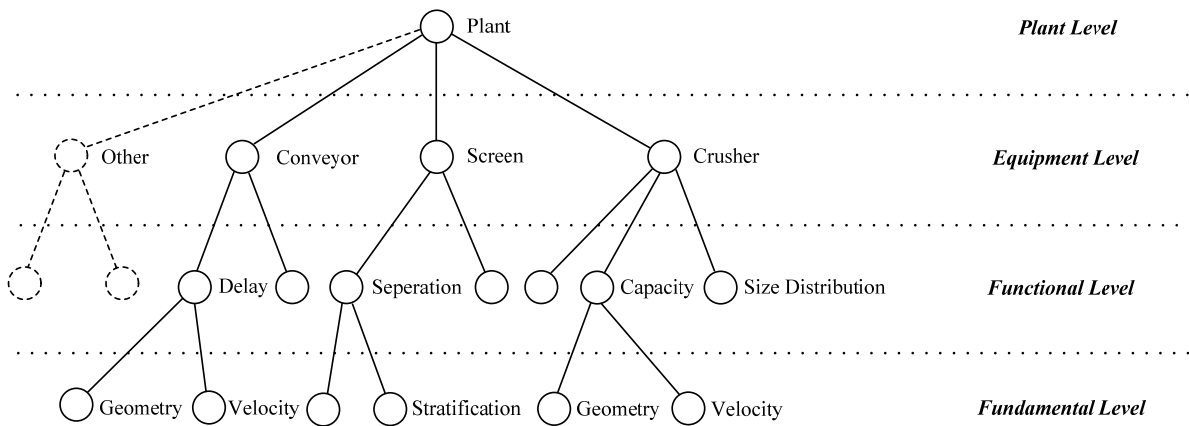

Figure 15. Illustration of the system hierarchy.

Since each single equipment model is an independent entity, the signal between the models needs to be standardized. The signal is transferred from one model to another and is transformed as it moves through each model. The signals contain information about the material which affects the performance of the system

The description of the material $u_{i,m}(t)$ includes information about the particle size distribution $f_i(t)$, the mass flow $\dot{m}(t)$ and properties of the material $\gamma(t)$ as illustrated in Eq. 5.1. Each model's output is bundled together into a vector which is sent as an input signal to the next model which in turn extracts the necessary information. Within each model a set of design parameters is defined as equipment specific input $u_{i,p}(t)$.

$$u_{i,m}(t) = \begin{bmatrix} f_i(t) \\ \dot{m}(t) \\ \gamma_i(t) \end{bmatrix} \quad (5.1)$$

Each module is expressed as a set of mathematical equations which is used to predict the performance of the system. The mathematical equations can be derived from fundamental principles of the physical behaviour of the system or empirically from experiments which aim to explain the correlation between different parameters. Simplifications and qualified assumptions are often needed in order to assure that the level of fidelity of the simulation matches the required computational time.

5.2 PLANT MODELLING

A crushing plant is a system of different production units and components connected together. The modelled system is built up by multiple subsystems connected together to form a plant model. A single crushing stage modelled in Simulink is illustrated in Figure 16. Each system consists of different time dependent production unit models that estimate the units' size reduction, size separation, material transport or material storage depending on the unit. Each involved subsystem is arranged in an appropriate process structure and connected together. Once the process has been defined, the machine and operating parameters are configured according to user preference. Appropriate material properties are specified and operating conditions are defined. Finally, control loops for the circuit are created and discrete events are defined. These factors will determine the predicted performance of the system.

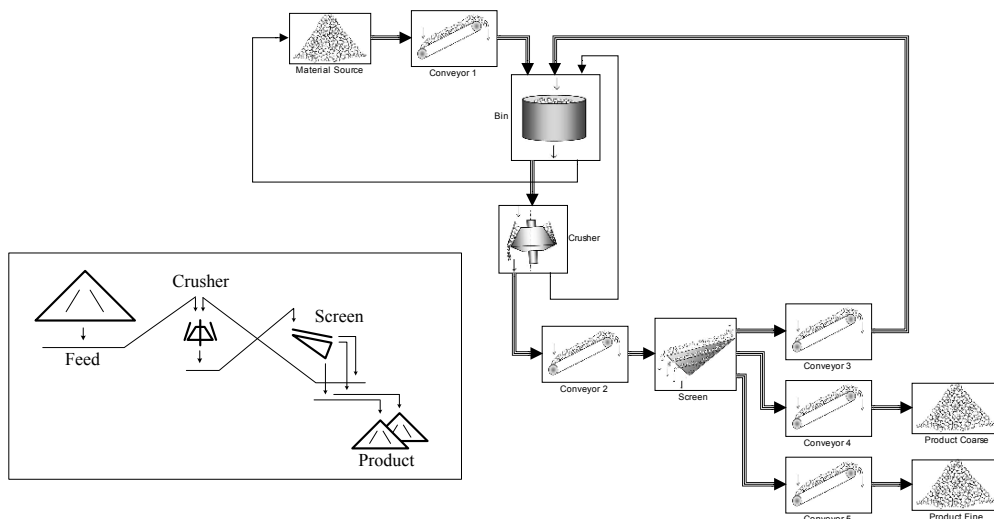

Figure 16. Flowsheet of a single crushing stage in Simulink with a simplified layout of the plant in the embedded picture. The broad signal lines between the production units represent the material signal presented in Eq. 5.1 while the thin signal lines are set points $y_{sp}(t)$ and process values $y_{i,p}(t)$.

The modelling work has been carried out with two different simulation platforms for comparison. The work was initiated with the simulation software SysCAD which is a commercial simulator with a built-in equipment library. The modelling work continued with Simulink in order to enable a more detailed level and flexibility of the models. Simulink is a commercial simulation software developed for simulating and analysing dynamic and discrete systems by Mathworks. It is widely used within many different types of industries as well as within academia for representing process behaviour and control systems. Simulink provides a graphical programming user interface with block-oriented modelling.

5.3 MODELLING SYSTEM DYNAMICS

The essential modelling principle in traditional steady-state simulation is that the system is at mass balance and with all derivatives equal to zero, Eq. 5.2. A general mass balance equation for a three stream connection point is illustrated in Eq. 5.3 where a_{SR} is the split ratio of the incoming mass flow, \dot{m}_{in} , to the two outgoing mass flows, $\dot{m}_{1,out}$ and $\dot{m}_{2,out}$.

$$\frac{dx_i(t)}{dt} = f(x_1(t), \dots, x_n(t), u_1(t), \dots, u_m(t)) = 0 \quad (5.2)$$

$$\left. \begin{array}{l} \dot{m}_{1,out} = (1 - a_{SR})\dot{m}_{in} \\ \dot{m}_{2,out} = a_{SR}\dot{m}_{in} \end{array} \right\} \Rightarrow \dot{m}_{in} = \dot{m}_{1,out} + \dot{m}_{2,out} \quad (5.3)$$

In a dynamic system, the system experiences different operating conditions when changes occur in the system. This results in the time-derivative not being equal to zero as defined in Eq. 5.2. These dynamics are usually consequences of an altered state of the plant over time due to factors such as natural variations, unmatched, inappropriate or degrading equipment performance and stochastic events.

In Figure 17 a general representation of a dynamic system is illustrated. The process model illustrated in Figure 17 represents a single unit which can be a crusher, a screen, a conveyor, etc. The input u includes information about the material characteristics ($u_{i,m}(t)$ in Eq. 5.1) and the design parameters $u_{i,p}(t)$. The material characteristics information fed into the model is the cumulated particle size distribution, mass flow and material properties as illustrated in Eq. 5.1. While the design parameters are the settings of the production unit involved, these can be fixed, such as Eccentric Throw (ET) in a crusher, or variables which can change over time, such as CSS. The disturbance, denoted with $w_i(t)$, illustrates the external changes in the process causing both gradual and discrete changes in the performance. The output $y_{i,m}(t)$ is the transformation of material through the model and $y_{i,p}(t)$ is equipment specific process value such as levels and power draw. The output signals are constructed in the same way as the input signals as they are often sent to a subsequential model. The internal state variable x and the differentiation of variable x describe the state of the system such as the accumulation of mass.

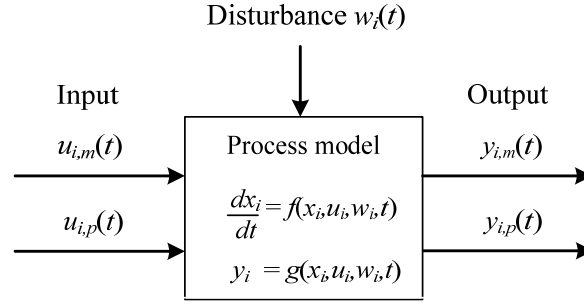

Figure 17. General representation of a dynamic system. The output $y_{i,m}$, $y_{i,p}$ and dx_i/dt are functions of inputs $u_{i,m}$ and $u_{i,p}$, the disturbance w_i and the internal state variable x_i , with respect to time t .

5.3.1 CONSERVATION OF MASS

One of the fundamental principles of simulating dynamic systems is the conservation of mass. In the mass balance equation previously presented, in Eq. 5.3, it was presumed that the total mass flow into the system was equal to the mass flow out of the system. In a dynamic simulation these constraints do not need to be fulfilled to have a system in mass balance. Instead the accumulated material in the system will change according to Eq. 5.4.

$$\frac{dm(t)}{dt} = \dot{m}_{i,in}(t) - \dot{m}_{j,out}(t) \quad (5.4)$$

The mass in the system $m(t)$ is therefore a result of the mass flow into the system $\dot{m}_{i,in}(t)$, minus the mass flow out of the system $\dot{m}_{j,out}(t)$. Mass cannot disappear nor be created, except in the source material block. The particle size distribution and the properties of the material $\gamma(t)$, in Eq. 5.5, such as shape, density and material strength are retained within the bulk material with a perfect mix model that is dependent on the accumulation of material and the mass flow into the system $\dot{m}_{i,in}(t)$ as illustrated in Eq. 5.6.

$$\gamma_i(t) = \begin{bmatrix} \gamma_1(t) \\ \gamma_2(t) \\ \vdots \\ \gamma_n(t) \end{bmatrix} \quad (5.5)$$

$$\frac{d\gamma_i(t)}{dt} = \frac{\dot{m}_{i,in}(t)}{m(t)} (\gamma_{i,in}(t) - \gamma_i(t)) \quad (5.6)$$

In Paper B a bin model was developed to estimate funnel flows in bins that are designed with a large flat bottom. This bin model was needed to increase the fidelity of the simulation due to process disturbance from uneven material flow and dead volumes. The developed model is depicted in two dimensions in Figure 18 where the bin is divided into several segments n in order to simulate the flow within the bin. A third dimension can be included with additional modelling and constraints to further increase the fidelity of the flow.

The model is defined by the number of segments n within the system and bed surface behaviour ($y_1(t), y_2(t), \dots, y_n(t)$). The feed i_f and product i_p placement are positioned in an appropriate section according to the reference. The basic measurements for the bin are entered: length l_g , width w_g and height h_g , in order to estimate the available space within the system. Looking into a single segment, the mass flow ($\dot{m}_{in}(t), \dot{m}_{in,Left}(t), \dot{m}_{in,Right}(t), \dot{m}_{out}(t), \dot{m}_{out,Left}(t)$ and $\dot{m}_{out,Right}(t)$) and bulk density ρ within that particular segment can be described by Eq. 5.7.

$$\frac{dy_i(t)}{dt} = \frac{n}{wl\rho} (\dot{m}_{in}(t) + \dot{m}_{in,Left}(t) + \dot{m}_{in,Right}(t) - \dot{m}_{out}(t) - \dot{m}_{out,Left}(t) - \dot{m}_{out,Right}(t)) \quad (5.7)$$

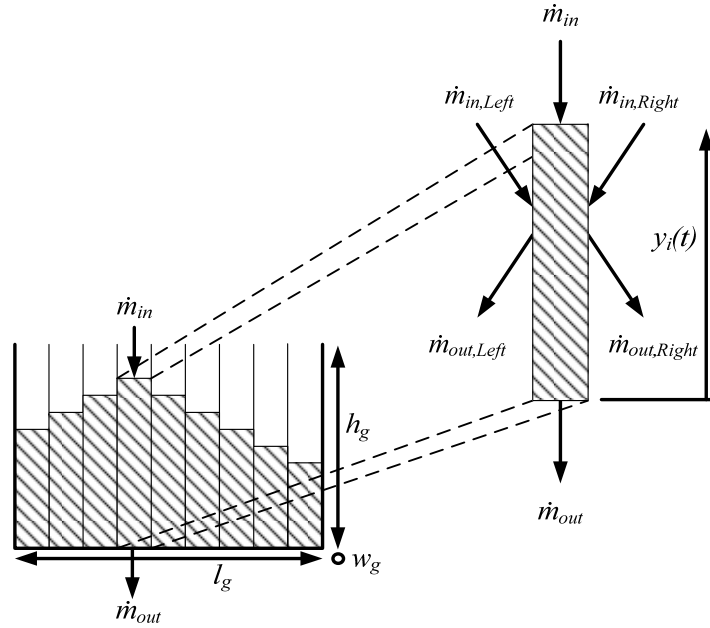

Figure 18. Principle idea with the segmented bin model.

During operation, as well as in simulations, the material focus is always on the total mass of the transported material. This is measured during operation with belt scales but this has to be changed into volumetric flow to be able to calculate the amount of space that a specific mass occupies. Volumetric flow rate $\dot{V}(t)$ is defined in Eq. 5.8, where $dV(t)$ equals the change in volume, $dm(t)$ equals the change in mass, dt is the time interval for the mass and ρ is the density of the bulk material.

$$\dot{V}(t) = \frac{dV(t)}{dt} = \frac{dm(t)}{\rho dt} \quad (5.8)$$

The flow of material within the bin will determine the material flow in the bin $\dot{m}_{in}(t)$, from the bins $\dot{m}_{out}(t)$ and surface level y . Since the material is segmented into n number of segments, the flow between segments is constrained by conditions that depend on the volume available in neighbouring segments i , the angle of repose α , the length of the bin l_g and the section placement of the feed inlet i_f and product outlet i_p respectively. In Eq. 5.9 the fundamental constraints of the flow are given and in Figure 19 a representation of flow during different conditions is illustrated.

(5.9)

$$\dot{m}_{in}(i) = \begin{cases} \dot{m}_{in}(t) & \text{if } \rightarrow y(i_p) - y(i) < \frac{l_g}{n} \tan(\alpha) |i_p - i| \\ \dot{m}_{in}(t) / \sum (y(i_p) - y(i) < \frac{l_g}{n} \tan(\alpha) |i_p - i|) & \text{if } \rightarrow y(i_p) - y(i) > \frac{l_g}{n} \tan(\alpha) |i_p - i| \end{cases}$$

$$\dot{m}_{out}(i) = \begin{cases} \dot{m}_{out}(t) & \text{if } \rightarrow y(i_f) - y(i) > \frac{l_g}{n} \tan(\alpha) |i_f - i| \\ \dot{m}_{out}(t) / \sum (y(i_f) - y(i) > \frac{l_g}{n} \tan(\alpha) |i_f - i|) & \text{if } \rightarrow y(i_f) - y(i) < \frac{l_g}{n} \tan(\alpha) |i_f - i| \end{cases}$$

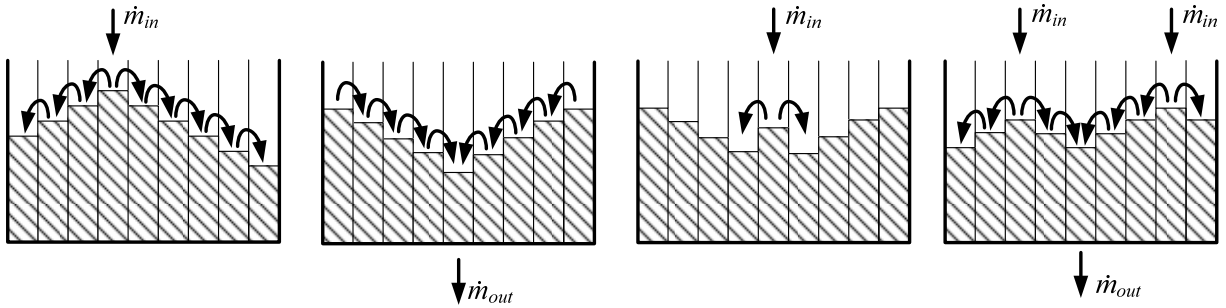

Figure 19. Representation of the flow under different conditions.

In Paper F a model for laminar material flow was presented. A perfect mixed model, as described by Eq. 5.6, perfectly blends the material and smoothens out all discrete changes in the particle size distribution and material properties. A first in-first out (FIFO) bin model was developed which was able to represent the laminar flow that can occur in bins with a high height-to-width ratio and steep bottom angle, see Figure 20 [93].

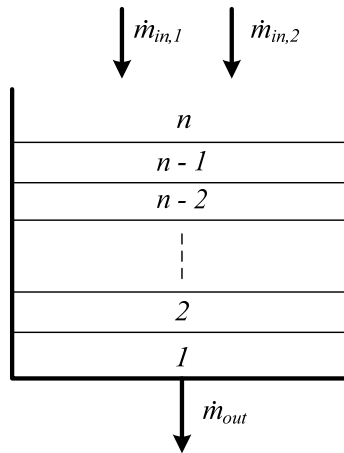

Figure 20. Principle idea with the FIFO bin model.

In a bin or a hopper with a complex geometry there will be a nonlinear relationship between measured level and occupied volume within the system. In Paper H a non-linear function was proposed to represent this relationship in a crusher hopper, see Figure 21.

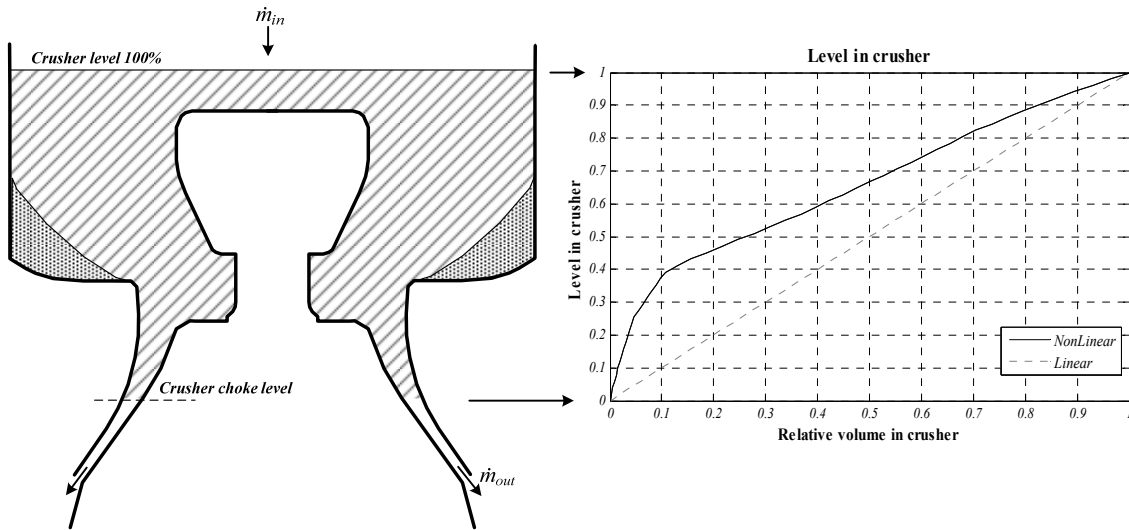

Figure 21. The relation between occupied volume and level in crusher. The available volume is marked with a cross-hatched area while the dead volume is marked with the shaded area.

5.3.2 DISCRETE EVENTS

During operation, plants should operate at or near full capacity. But due to different unit's reliability and maintenance strategy there are always disturbances in the process due to starts and stops of individual units which will affect the process. In a worst case scenario the disturbance may cause a considerable downtime (DT) for the entire plant. The reasons for stopping the process can be anything from scheduled maintenance, for keeping a certain product quality, to a total machine breakdown as depicted in the two scenarios in Figure 22.

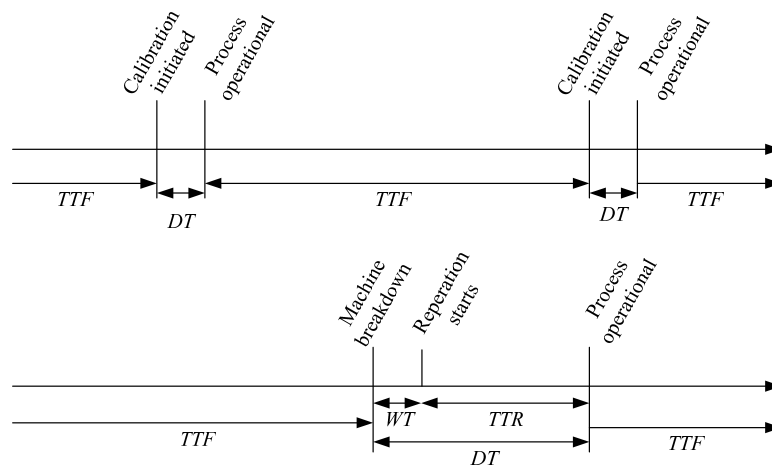

Figure 22. Two different scenarios for discrete events. The scenario above illustrates the calibration process as an event while the scenario below illustrates the consequence of machine breakdown.

The length of each downtime is determined by how well the plant is prepared to handle particular events and the severity of the breakdown. Events can be entered manually into the simulation as a single event or for deeper analyses a Discrete Event Simulation (DES) can be performed creating a hybrid simulation with discrete and continuous simulation running simultaneously. The DES model is used to represent batches and events which can in turn be used to automatically generate events that can disturb the process. The output from a DES would therefore be the time-to-failure (TTF), waiting time (WT) and time-to-repair (TTR), all being dependent on the probability of the event occurring and the severity of the problem [94].

DES models can be roughly classified into two categories, deterministic and probabilistic. With deterministic events the time and length of events are determined in advance which will give the same results every time, given that the initial conditions are the same. With probabilistic events however, the time and length of each event are not predetermined, instead the events occur depending on the selected probability distribution [15]. The principle of DES models for different events is illustrated in Figure 23 (Paper H). All discrete simulations were performed with SimEvent which is a toolbox of Simulink.

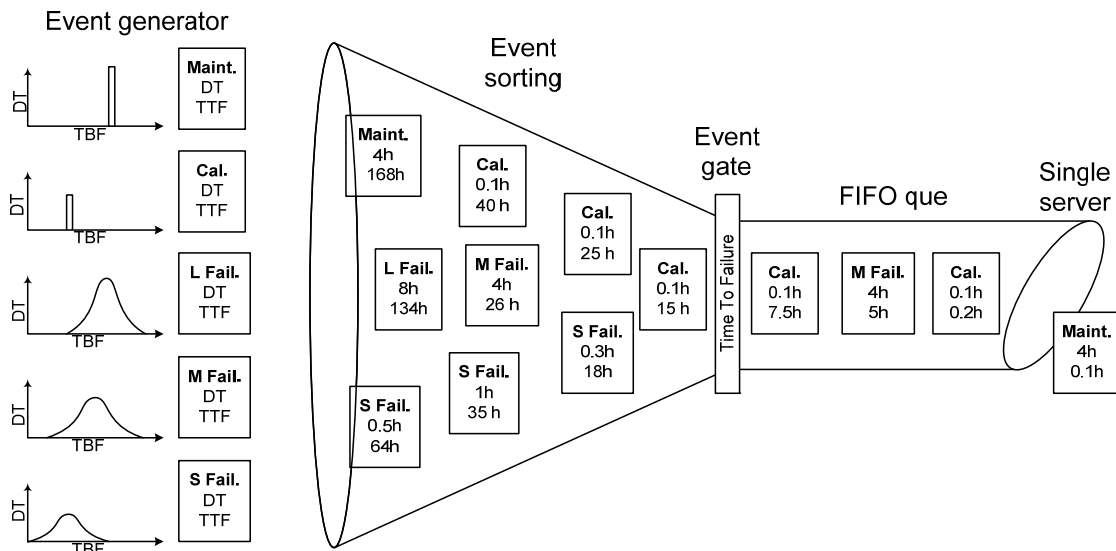

Figure 23. The principles of discrete event modelling for the process.

The definitions of different types of DT events are given in Table 1:

Table 1. Categorising the discrete events in the process.

Type	Probability	Description
External	Stochastic	Uncontrollable events outside the process
Upstream	Deterministic/Stochastic	Operational stop or stand by due to lack of feed
Downstream	Deterministic/Stochastic	Operational stops by due to downstream process full or down
In-stream	Deterministic/Stochastic	Delay or Standby due to lack of control
Failure	Stochastic	Break down that require unscheduled maintenance
Maintenance	Deterministic	Scheduled maintenance

Mechanical failures in the process were included as stochastic events with probability of failure as a function of maintenance. The failure probability is modelled as a Weibull distribution and an exponential distribution in SimEvents as shown in Eq. 5.10 and Eq. 5.11. The parameters k and λ describe the form of the distributions.

$$f(t, k, \lambda) = \frac{k}{\lambda} \left(\frac{t}{\lambda} \right)^{k-1} e^{-(t/\lambda)^k} \quad (5.10)$$

$$f(t, \lambda) = \lambda e^{-\lambda t} \quad (5.11)$$

5.3.3 DYNAMIC SYSTEM RESPONSE

How a model responds to a change in a parameter during operation is crucial for the dynamic behaviour of the system. One way of simulating the step or impulse response of a system is with a differential equation or with a corresponding transfer function which can be derived analytically or empirically. Step responses from a first order system, a second order system and a pure time delay are illustrated in Figure 24 and given in Eq. 5.12-5.20.

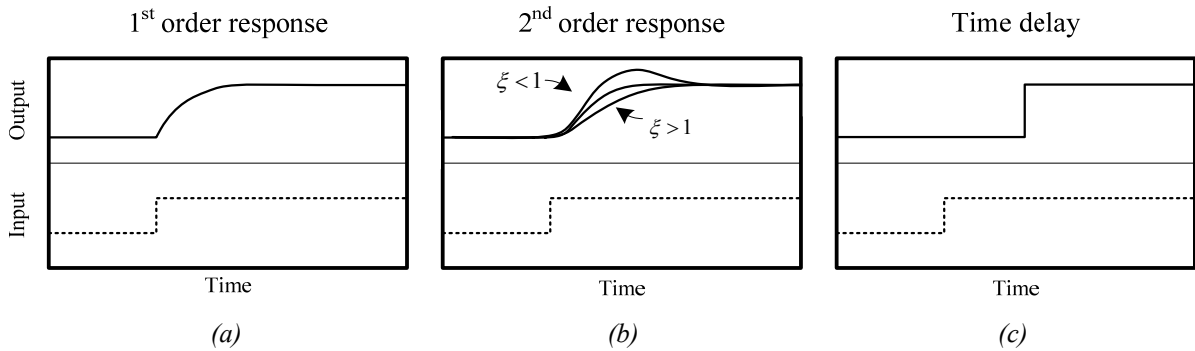

Figure 24. Step response for a first order system (a), a second order system (b) and a pure time delay (c).
Modified from Marlin [95].

The response of a first order system (Figure 24a) is usually given by a simple first order differential equation in time domain or by the corresponding transfer function in frequency domain which is illustrated in Eq. 5.12 and Eq. 5.13. The parameter s is the Laplace operator. The time constant, which is denoted with a τ , is the time which the system takes to reach 63.2% of the final steady-state value which is equal to the steady-state process gain K and the difference in the forcing input $u(t)$.

$$\tau \frac{dy}{dt} + y(t) = Ku(t) \quad (5.12)$$

$$G(s) = \frac{Y(s)}{U(s)} = \frac{K}{\tau s + 1} \quad (5.13)$$

A second order system can be described with both a second order ordinary differential equation and with the corresponding transfer function in Eq. 5.14. A second order response can also be achieved by having two first order systems in a series. As with a first order system, a second order system is described with a time constant τ and the forcing function $Ku(t)$. However, an additional factor is included, the parameter ζ which is termed the damping coefficient. The damping coefficient determines if the step response which is depicted in Figure 24b, is overdamped ($\zeta > 1$), underdamped ($\zeta < 1$) or critically damped ($\zeta = 1$). If the parameter ζ is too low the system will continue oscillating over a long time.

$$G(s) = \frac{Y(s)}{U(s)} = \frac{K}{\tau^2 s^2 + 2\zeta\tau s + 1} \quad (5.14)$$

In Papers C-H a first order transfer function with delay (FOTD) was applied to the feeders installed throughout the circuit. However, in Paper F, system identification was used to get a more accurate estimation of the system response. Figure 25 illustrates the system boundaries for the system identification.

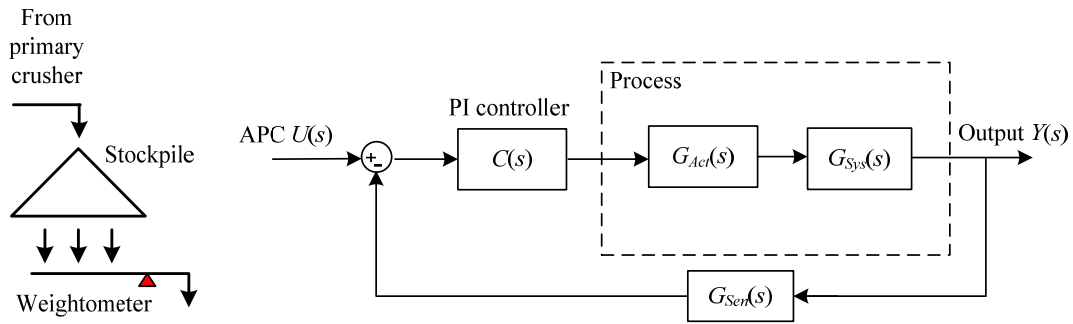

Figure 25. Illustration of the system used for system identification.

Six different linear time-invariant (LTI) models were estimated to be able to represent the system dynamics. These are LTI models with one, two or three poles, with and without zeros τ_z , critically damped with dead time θ and lag time τ_i , Eq. 5.15 - Eq. 5.20.

$$G_{P1D}(s) = \frac{Y(s)}{U(s)} = \frac{K}{1 + \tau_1 s} e^{-\theta s} \quad (5.15)$$

$$G_{P2D}(s) = \frac{Y(s)}{U(s)} = \frac{K}{(1 + \tau_1 s)(1 + \tau_2 s)} e^{-\theta s} \quad (5.16)$$

$$G_{P3D}(s) = \frac{Y(s)}{U(s)} = \frac{K}{(1 + \tau_1 s)(1 + \tau_2 s)(1 + \tau_3 s)} e^{-\theta s} \quad (5.17)$$

$$G_{P1DZ}(s) = \frac{Y(s)}{U(s)} = \frac{K(1 - \tau_z s)}{1 + \tau_1 s} e^{-\theta s} \quad (5.18)$$

$$G_{P2DZ}(s) = \frac{Y(s)}{U(s)} = \frac{K(1 - \tau_z s)}{(1 + \tau_1 s)(1 + \tau_2 s)} e^{-\theta s} \quad (5.19)$$

$$G_{P3DZ}(s) = \frac{Y(s)}{U(s)} = \frac{K(1 - \tau_z s)}{(1 + \tau_1 s)(1 + \tau_2 s)(1 + \tau_3 s)} e^{-\theta s} \quad (5.20)$$

A best fit was obtained with a LTI model with a single pole and a single zero. The fitted responses from the six models are illustrated in Figure 26 and the step response of each model is illustrated in Figure 27. The best fit response is marked with a blue thick line in Figure 27.

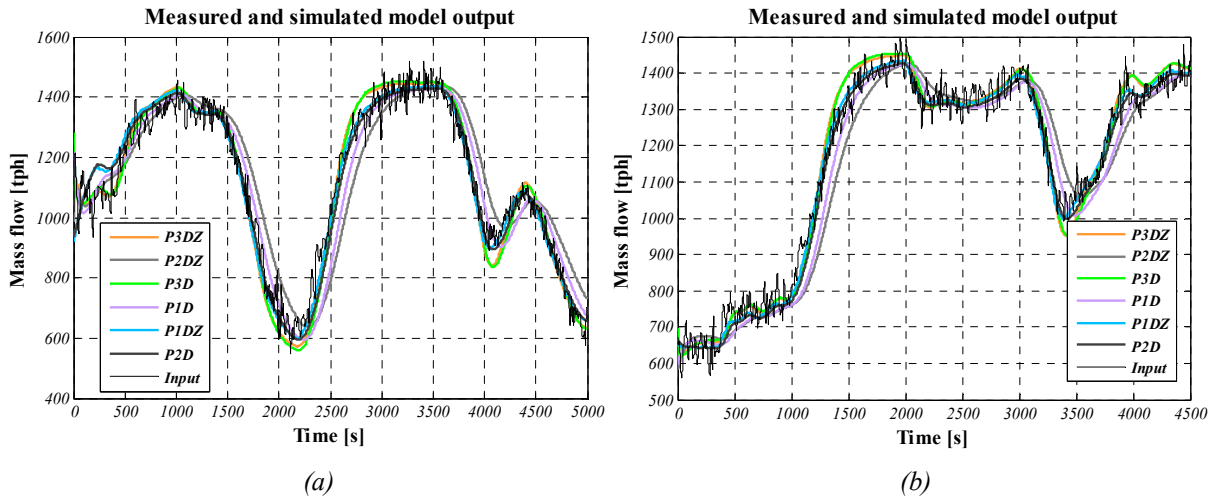

Figure 26. Measured and modelled response of the stockpile feeder for model fitting period (a) and validation period (b).

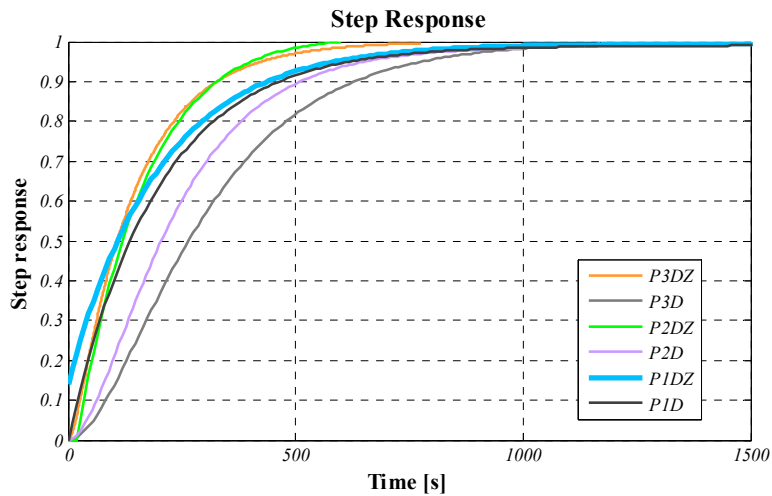

Figure 27. The step response of the different functions. The best fit was obtained with a first order transfer function with a zero (marked with a thick blue line).

The third part illustrated in Figure 24c is the dead time or transportation delay of the system. The dead time is the delayed step response of the system, the change in the input parameter u does therefore not affect the system output $y(t)$ until after the determined delay time θ has passed, as illustrated in Eq. 5.21 and Eq. 5.22.

$$y(t) = u(t - \theta) \quad (5.21)$$

$$G(s) = \frac{Y(s)}{U(s)} = e^{-\theta s} \quad (5.22)$$

Estimating the transport delay of a material is in some cases insufficient with a pure time delay. If a conveyor is equipped with a variable speed drive the material will have different dead time depending on the speed of the conveyor and the position of the material. In Paper E a state-space conveyor model capable of estimating the change in mass flow was presented, Eq. 5.22. This model keeps track of the material on the conveyor, allowing the user to manipulate the speed v of the conveyor and enable the stopping of the conveyor without deleting material. The level \dot{x}_i in each segment is a function of conveyor speed v , conveyor length l_g , conveyor width w_g , the mass flow x_i between each segment, material density ρ and the number of sections n the conveyor is divided into.

$$\begin{bmatrix} \dot{x}_1 \\ \dot{x}_2 \\ \vdots \\ \dot{x}_n \end{bmatrix} = \begin{bmatrix} -a & 0 & \cdots & 0 & 0 \\ a & -a & \cdots & 0 & 0 \\ \vdots & \vdots & \ddots & \vdots & \vdots \\ 0 & 0 & \cdots & -a & 0 \\ 0 & 0 & \cdots & a & -a \end{bmatrix} \begin{bmatrix} x_1 \\ x_2 \\ \vdots \\ x_n \end{bmatrix} + \begin{bmatrix} 1 \\ 0 \\ \vdots \\ 0 \end{bmatrix} \cdot \frac{\dot{m}_{in} n}{\rho l_g w_g}, \quad a = \frac{vn}{\rho l_g} \quad (5.22)$$

The residence time of the material within different units is dependent on the material flow. The transport time for a particle travelling over a screening deck has been described by Soldinger Stafhammar [9]. In Papers E-H the Soldinger Stafhammar velocity model was used to estimate particles residence time on the screen. Where $l_{g,screen}$ is the length of the screen, f_n is the frequency of the deck, α is the slope and ET is the throw of the deck, Eq. 5.23.

$$t_{screen} = l_{g,screen} / ((0.064\alpha + 0.2)(380ET - 0.18)(0.095f_n\alpha^{-0.5} + 0.018\alpha - 0.38)) \quad (5.23)$$

For a cone crusher the residence time $t_{crusher}$ is dependent on the occupied volume in the crusher hopper and the ES of the mantle. In Evertsson [6] a velocity profile in a vertical direction during a single nutation is derived. The residence time above the mantle is dependent on the mass flow out of the crusher while during crushing the residence time is dependent on the particles average velocity v , which is a function of ES, and the height of the mantle $l_{g,mantle}$, Eq. 5.24.

$$t_{crusher} = l_{g,mantle} / v + \frac{m(t)}{\dot{m}_{out}(t)} \quad (5.24)$$

5.3.4 WEAR

The crushing process is constantly affected by wear which causes gradual performance deterioration. How the wear affects the process is dependent on multiple factors. These include the characteristics of the equipment subjected to wear, the geometry of affected components and the properties of the rock material: mineral content, particle size distribution, moisture and more.

In Paper A, a specific focus was on the effect gradual wear has on a cone crusher and how it affects the product mass flow in the crushing circuit. The studied plant was an aggregates plant 80 km north of Gothenburg, which produces high-quality aggregates from granitic gneiss, ranging in size from 0-2 mm to 16-22 mm. All 10 conveyors in the tertiary phase of this plant were equipped with power meters that monitored and logged the electrical power draw. From these data, the mass flow could be calculated and changes in the particle size distribution estimated.

In Figure 28 and Figure 29 the calculated change in particle size distribution, due to wear, is expressed as the change in the size of the 50 % passing size x_{50} and the shape of the particle size distribution curve b as a result of a fitted Swebrec function [96] Eq. 5.25, to the logged production data. In Figure 30 the calculated change in the x_{50} parameter is displayed together with interpolated data between the measured CSS. Approximately one hour separated each measurement.

$$f(x) = \left(\frac{\ln\left(\frac{x_{max}}{x}\right)}{\ln\left(\frac{x_{max}}{x_{50}}\right)} \right)^b \quad (5.25)$$

Figure 31 shows the collected data, which is presented as a change at defined intervals, from the calibrations. Fitting a linear regression to the data points provides a simplified indication of the wear trend that occurred during the experiments. Looking at the wear rate in each single run, the rate varies between 0-3 mm/hour but when calculated together the wear rate becomes close to constant just below 1 mm/hour.

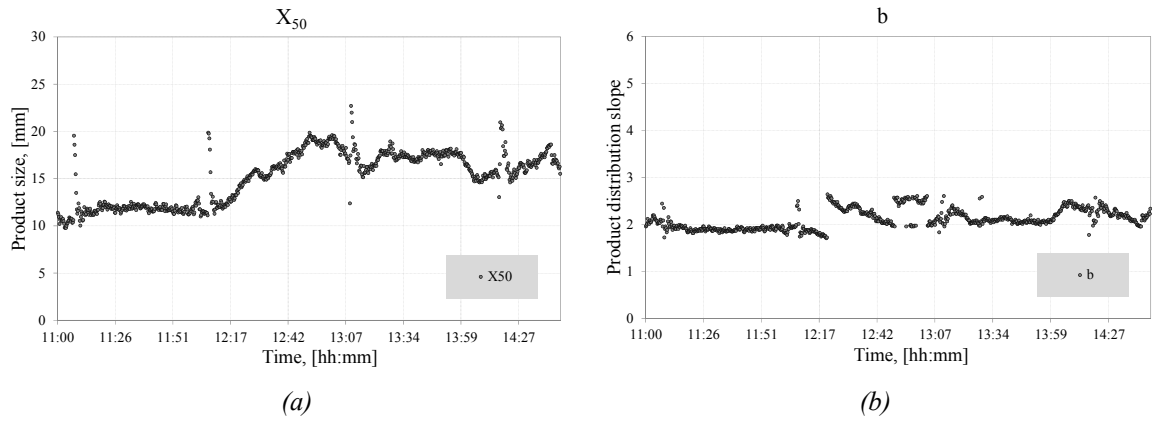

Figure 28. Calculated change in the particle size distribution, x_{50} (a) and b (b), over time from the logged process readings of day 1.

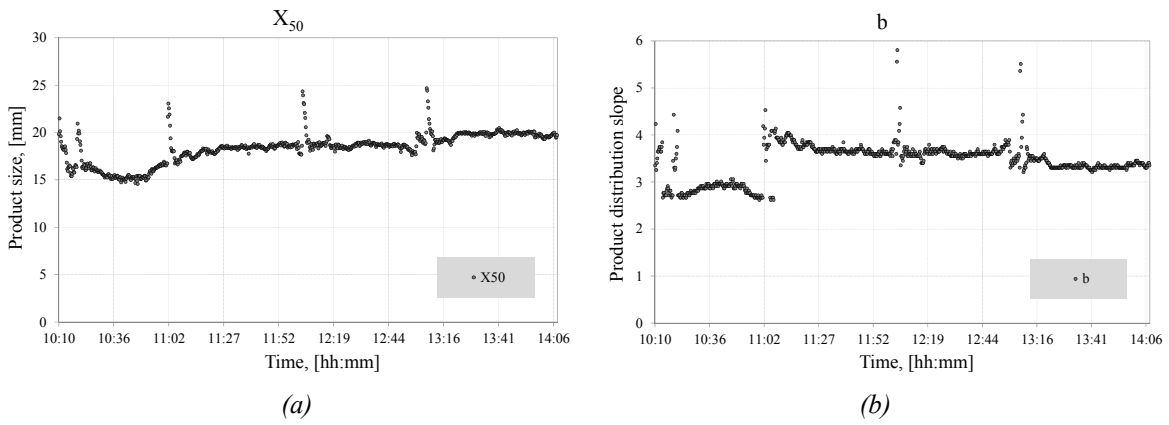

Figure 29. Calculated change in the particle size distribution, x_{50} (a) and b (b), over time from the logged process reading of day 2.

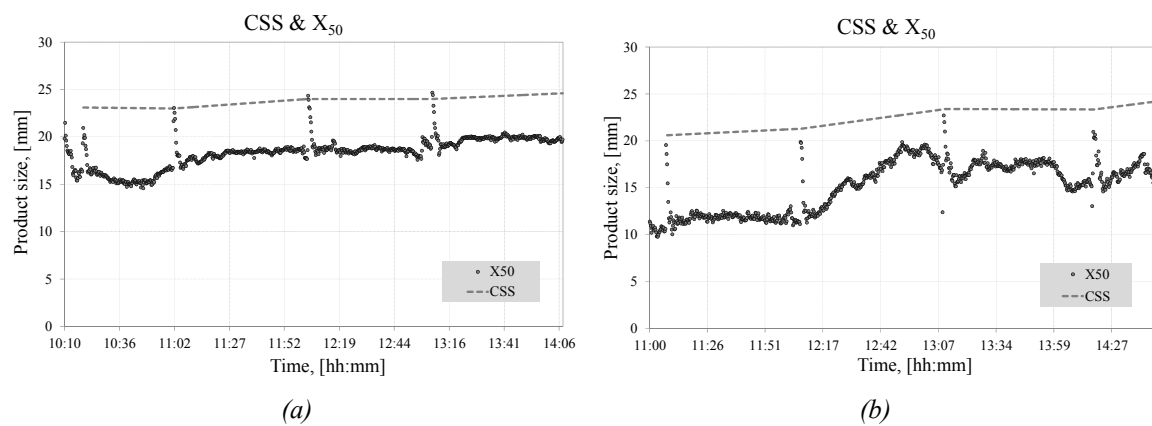

Figure 30. The trend of CSS (dotted grey line - interpolated between tests) and x_{50} (black dots - calculated from logged process readings) as a function of material flow through the crusher in two of the experiments, (a) and (b). The results are close to parallel. Spikes in the x_{50} curve indicate an interruption in the process due to calibrations or mechanical failure.

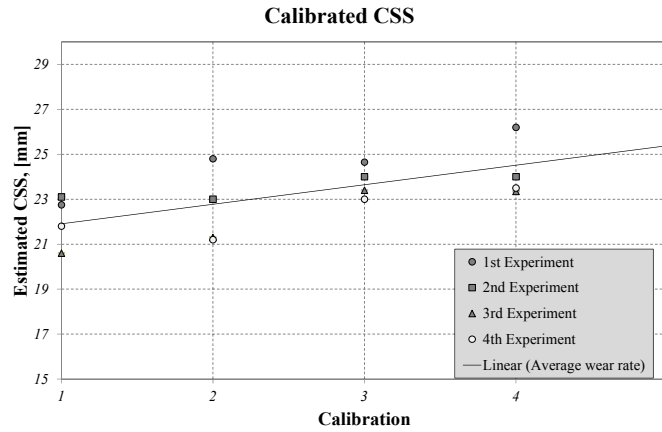

Figure 31. Linear regression of the wear trend (black line) generated from the results of the calibrations.

Eq. 5.20 was formulated to describe the changes in parameter x_{50} , given that the particle size distribution of the feed remains close to constant. Parameter a_1 is a function of the incoming particle size distribution and the condition of the crushing chamber which represents the ratio between the initial $CSS(t_0)$ and x_{50} . The parameter a_2 represents the wear rate depending on the amount of crushed material ($m_{crushed}(t)$) per hour.

$$x_{50} = a_1 CSS(t_0) + a_2 \int_{t_0}^t m_{crushed}(t) dt \quad (5.20)$$

5.3.5 VARIATIONS

One of the many factors that affect the plant performance is variation. Since the material is blasted from a solid bedrock the size distribution and mechanical properties of the rock is dependent on the type of explosives, the amount and location of the charge, the blast formation pattern and the geological formation of the bedrock [96]. In Papers A, C and H a varying particle size distribution of the feed was included. Figure 32 illustrates 25% increase and decrease around the reference feed size distribution to the circuit in Paper H.

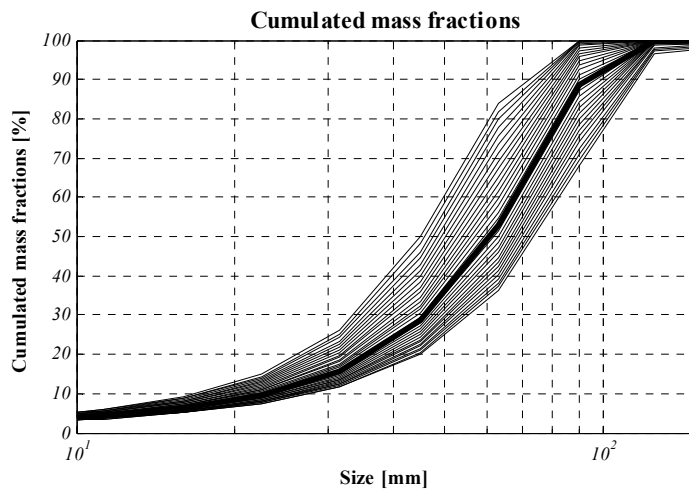

Figure 32. Systematic variation in the incoming feed from Paper H.

6 CRUSHING PLANT CONTROL

The aim of this chapter is to:

- Introduce the different control strategies applied in this thesis.

Due to the characteristics of dynamic simulation the material stockpiles, bins and flows need to be controlled as in reality. In crushing plants different types of control systems are commonly used to ensure safe and robust operation while striving for high product quality and high production throughput. In this thesis the controllers are defined as regulatory and supervisory controllers.

6.1 REGULATORY CONTROL

The most common form of regulatory control in comminution is the feedback control loop as illustrated in Figure 33.

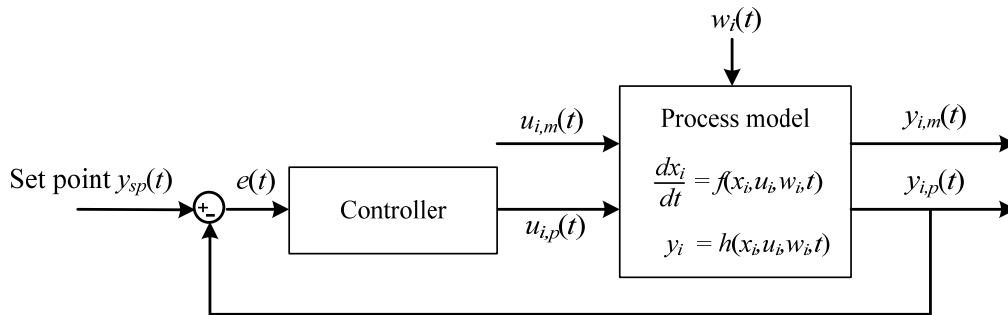

Figure 33. General representation of a feedback control loop. Modified from Marlin [95].

The feedback control loop works by manipulating variables $u_{i,p}(t)$ to change the measured control variable to a desired level in order to minimize the error $e(t)$ in Eq. 6.1, which is the difference between the process value $y_{i,p}(t)$ and the desired process value $y_{sp}(t)$.

$$e(t) = y_{sp}(t) - y_{i,p}(t) \quad \lim_{t \rightarrow \infty} e(t) = 0; \quad (6.1)$$

The controller regulates the process to minimize the variations in the process output by compensating for the effect of disturbances in the process $w_i(t)$ or an altered reference value $y_{sp}(t)$. The most commonly used feedback controller is the PID controller, Eq. 6.2. The PID controller, as the name indicates, uses three mathematical functions to regulate the process and compensate for the error.

$$u_{i,p}(t) = K_P e(t) + K_I \int e(t) dt + K_D \frac{d}{dt} e(t) \quad (6.2)$$

A PI controller, such as illustrated in Figure 34, has been applied in Papers A-H for necessary control loops. The controller compares the set point $y_{sp}(t)$ and the actual process value $y_{i,p}(t)$ of the corresponding level and regulates the process accordingly. The level signal which is a function of the mass flow and the geometry of the production unit is sent from the monitored production unit model to the controller model as a scalar signal. How the controller reacts to changes in the process is dependent on the value of the parameters K_P , K_I and K_D , in Eq. 6.2. An increase from the estimated dead time will drive the system to an unstable operation.

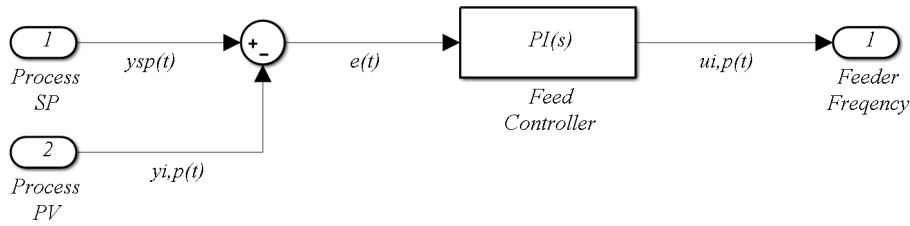

Figure 34. PI controller for the feeder frequency in Simulink.

In order to design a controller for the circuit a linear approximation can be done around the operational condition. Linear approximation has been used by Sbárbaro [54], Itävuo [71] and Airikka [70] in their controller tuning. The controller in this case aims to maintain a certain level in a bin above the crusher. A linear approximation for a part of the circuit from Paper H is shown in Figure 35.

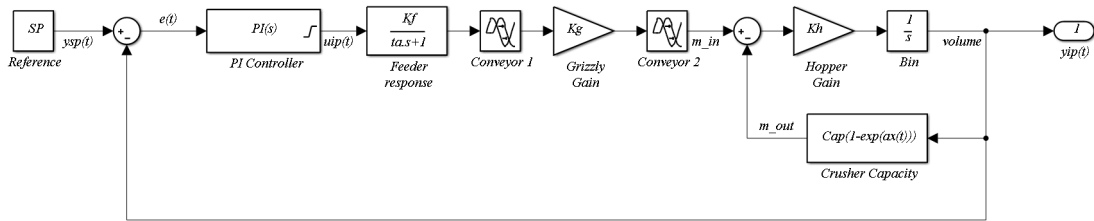

Figure 35. Linear approximation of the controlled part of a circuit.

The transient behaviour of the feeder is expressed with a LTI models. The s is the Laplace operator and the time constant, T , is the time which it takes the system to reach 63.2% of the final steady-state value which is equal to the steady-state process gain K_f and the difference in the forcing input $u_{i,p}(t)$. The split over the grizzly is represented with the gain K_g and conversion from mass flow to volumetric flow is given with the gain K_h .

Multiple controller tuning methods have been described by Åström [97]. In Papers A-G the controllers were tuned manually to give a reasonable response. The K_P and K_I parameters were automatically tuned in Paper H with a model-based approach in Simulink.

6.2 SUPERVISORY CONTROL

Supervisory controllers or Advanced Process Control (APC) aims to move the process output $y_{i,m}$ to an optimum process target by altering the regulatory controller's set point y_{sp} , as illustrated in Figure 36. This can be used for example to optimize a production of a particular product in aggregates production by altering crusher ES.

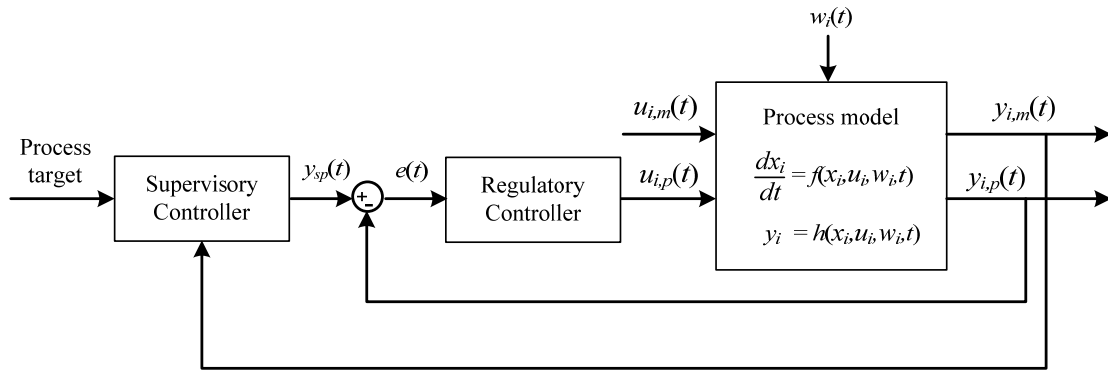

Figure 36. General feedback control loop with a supervisory controller for set point selection.

The development of an APC often entails the usage of dynamic models for predicting the behaviour of the system. This is to counteract the effect a change in the process has on the production before it occurs in the system. The models have to be sophisticated enough to be able to predict the performance of the system under different conditions.

In Paper D the purpose was to tune an existing control algorithm which has been developed by Hulthén [12]. The supervisory control algorithm was a Finite State Machine (FSM) which controls the ES of a crusher by making discrete step changes in speed (ΔES^+ and ΔES^-) with defined time intervals (LongTime) while observing the performance of the circuit. How the FSM works is illustrated in Figure 37.

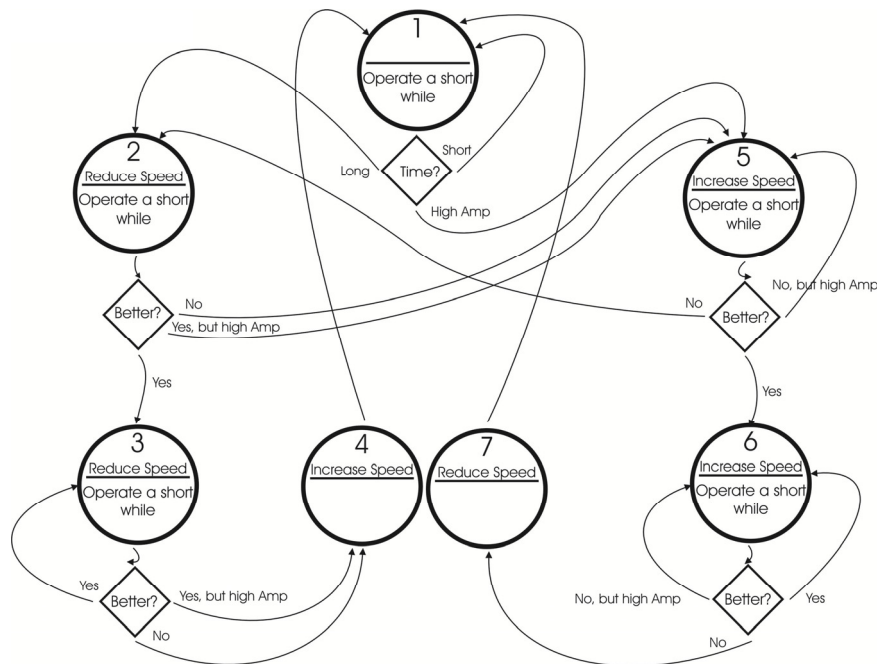

Figure 37. The FSM used for selecting appropriate ES [12].

In Paper F a supervisory control layer was implemented that includes model-based and model predictive control (MPC) capability for optimization purposes. The MPC calculates the various set point values for many of the regulatory controllers, and sets limits for some of the fuzzy logic rule-based controllers based on an economic objective function. The objective function was aimed to maximize the production of circuit product, while at the same time ensuring that the various constraints were not exceeded. An overview of the process layout and model predictive control parameters is shown in Figure 38.

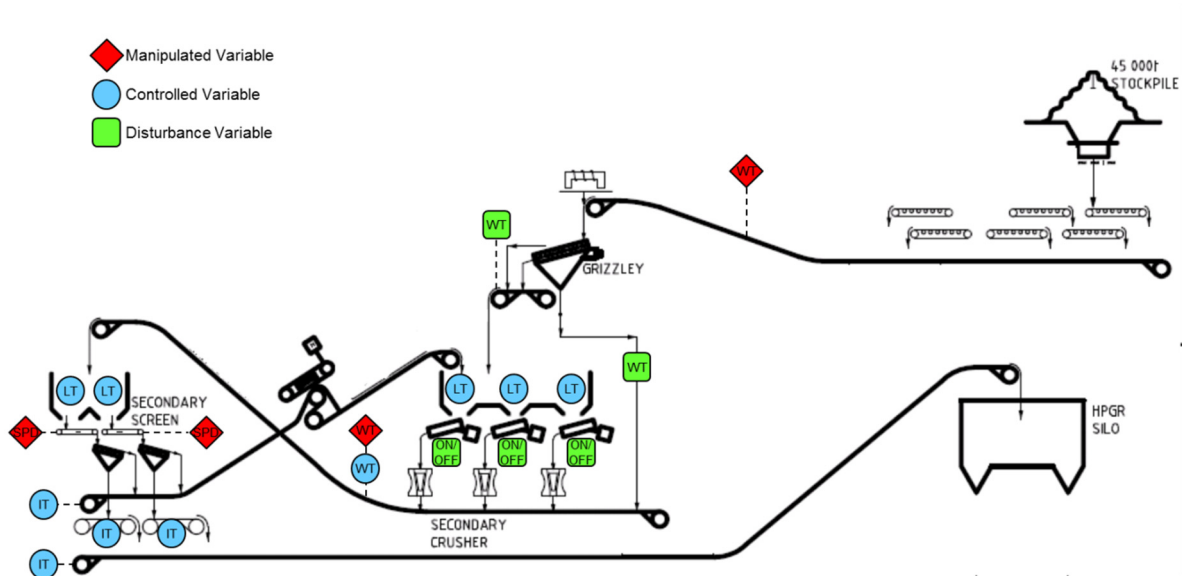

Figure 38. Process layout of the controlled process from Paper F. Picture provided by Duane Muller.

In order to drive maximum throughput, a “push-pull” control philosophy was implemented within the supervisory control layer. The “push” effect is achieved by introducing as much fresh feed into the circuit as the process states and limits allow by controlling the feed to the circuit. The “pull” effect is achieved by controlling the feeders below the screen bins, again subject to the process states and limits imposed by the equipment. This is achieved by using the belt scales on the crusher discharge conveyor as both a manipulated variable and a controlled variable. Using the discharge weight as an intermediate variable (both a manipulated variable and a controlled variable) enables accurate discharge weight control and as a result the disturbances affecting the screen bin level are minimized, and improved screen bin level control is achieved.

6.3 CONTROL IMPLEMENTATION

Incorporating the control system in a dynamic simulation makes it possible to test the control system in a controlled environment prior to commissioning of a plant. Unexpected consequences, such as instability and lack of robustness, can occur if the control system is implemented without a rigorous quality control of the code itself. In Paper D and F, two different methods of implementation of the supervisory controller were performed. In Paper D the FSM was included in the plant model with a function block, while in Paper F the control system was an offline version of an actual code at the plant and connected to the model from a third party software through an Object linking and embedding for Process Control (OPC) server.

7 PLANT PERFORMANCE

The aim of this chapter is to:

- *Demonstrate process improvements of crushing plants.*
- *Describe the performed user acceptance test.*
- *Describe process stability under different conditions.*

The traditional use of crushing plant simulators is to model, simulate and evaluate plant performance. In order to evaluate the performance of a particular plant a flowsheet of the plant is arranged so that it represents the layout of the plant. The plant can be an existing or non-existing plant, which usually affects the purpose of the simulation. The purpose can be to evaluate current configuration or assess different plant design alternatives.

Configuration of the equipment is done by selecting value for different production unit settings, such as CSS and screen apertures into appropriate unit models. Additionally the rock properties of the feed material are defined, such as particle size distribution, particle shape, material density and material strength. The steps above are applicable when dealing with steady-state simulation. However, when it comes to dynamic simulations additional aspects of the operation need to be considered such as material handling and control. After this has been done the simulation will determine the behaviour of the process over time and the performance of the system.

In the following sections the simulation results from Papers C, F and H are presented. The purpose of the simulations was to evaluate current design performance. This includes changed unit configuration in Paper A to achieve higher process saturation, user acceptance testing with experienced control engineers to validate process behaviour for model implementation in Paper F and to evaluate process performance under different feeding conditions in Paper H.

7.1 PROCESS IMPROVEMENTS

The general purpose of Paper C was to study how the plant operated under different operating conditions and find out what level of plant performance saturation could be achieved with implemented interlocks and PI controllers.

The modelled section consists of three cone crushers (a coarse crusher, intermediate crusher and a fine crusher) represented with empirical crusher performance models based on survey data. A single vibrating grizzly with sloth width from 80 mm, two double deck screens with top deck at 85x85 mm and bottom deck at 40x52 mm modelled with Reid-Plitt efficiency curve and two bins that are approximately 660 m³ and 300 m³, respectively. The incoming feed is a platinum group metal ore which has been crushed with a primary crusher down to approximately 0-250 mm, see Figure 40.

From a steady-state modelling perspective the plant would be modelled as depicted in Figure 39, with mass balance in point A and B and the performance determined by the crushers combined capacity. This will however give an unreliable result of the plant's actual performance, since dead time on conveyors and bin capacities affect how the process operates. The modelling approach in Figure 40 is therefore more suitable.

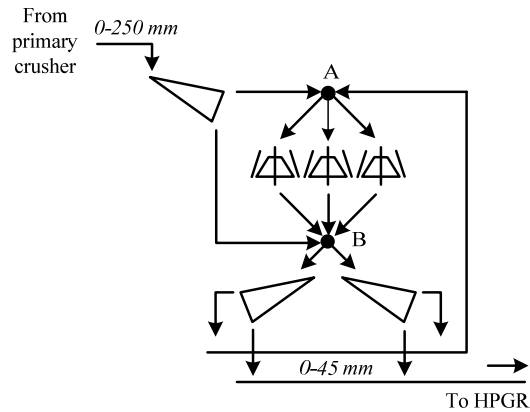

Figure 39. A steady-state view of the plant.

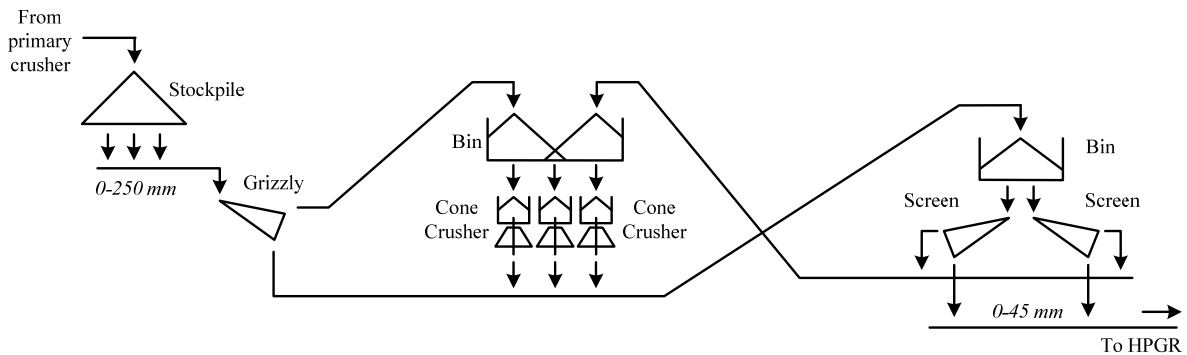

Figure 40. Flowsheet of the crushing section of the platinum processing plant as presented in Paper B.

Four different scenarios were simulated from different combinations of CSS and ET. The scenarios were configured according to the setup of the plant and from the measured process data, which was collected during two surveys. The first scenario involved simulating the process as it is usually configured and performed according to the surveys. In the second scenario the CSS of the coarse crusher was reduced from 55 mm to 40 mm. In the third scenario the ET of the fine crusher was increased from 38 mm to 44 mm. In the final scenario the changes from second and third scenario were implemented together.

7.1.1 PROCESS SIMULATION RESULTS

Variations in the particle size distribution and the mass flow were imposed and each scenario was simulated until it reached performance saturation. The simulation result from the 1250 tph target throughput in Scenario 1 is shown in Figure 41. Under these conditions the plant was stable and able to hold the target throughput of 1250 tph without any major fluctuations. However, in Figure 42, input feed rate was increased up to 1500 tph which caused the process to start fluctuating. Under these conditions the plant was not stable due to active triggers and the overall performance achieved became lower than the target feed rate.

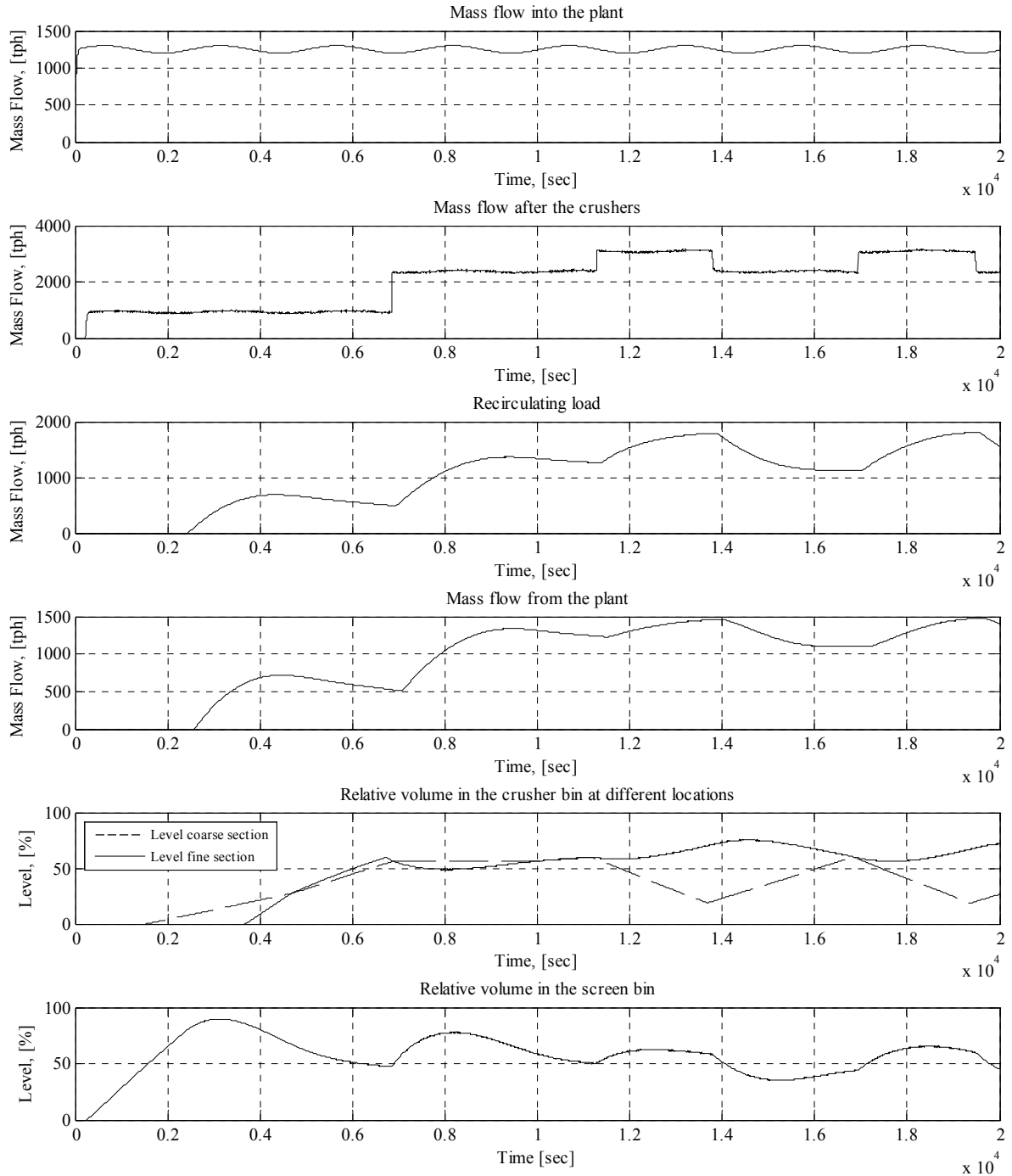

Figure 41. Simulation results from simulating 1250 tph in Scenario 1. The process is relatively stable with minor fluctuation.

CRUSHING PLANT DYNAMICS

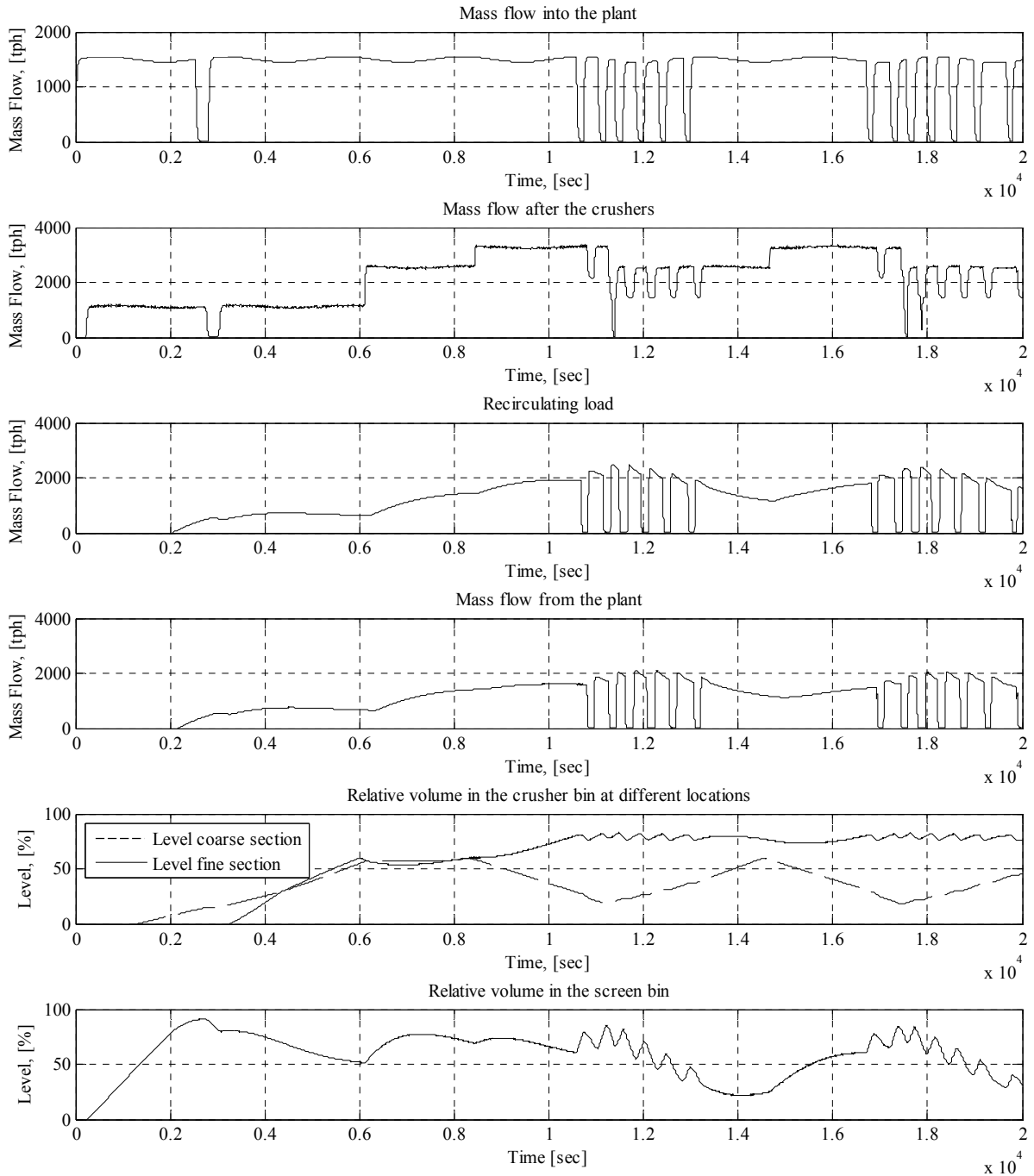

Figure 42. Simulation results from simulating 1500 tph in Scenario 1. The process starts experiencing major fluctuation after approximately 3 hours.

The results from the simulated scenarios in Figure 43 illustrate how the average performance of the plant reaches a maximum level at a certain feeder target feed rate. This is where the interlocks from the bins start interrupting the process due to overload. To respond to the overload the incoming feed into the circuit is shut off causing an unstable pattern in the process. Up to this point the plant experiences steady-state behaviour. The reference scenario (Scenario 1) was able to produce approximately 1275 tph in an uninterrupted operation. While, Scenario 2 and Scenario 3 were able to increase the overall capacity by 4.7 % resp. 8.2 %. The combined factors in Scenario 4 revealed a possible 13.3 % increase in plant capacity.

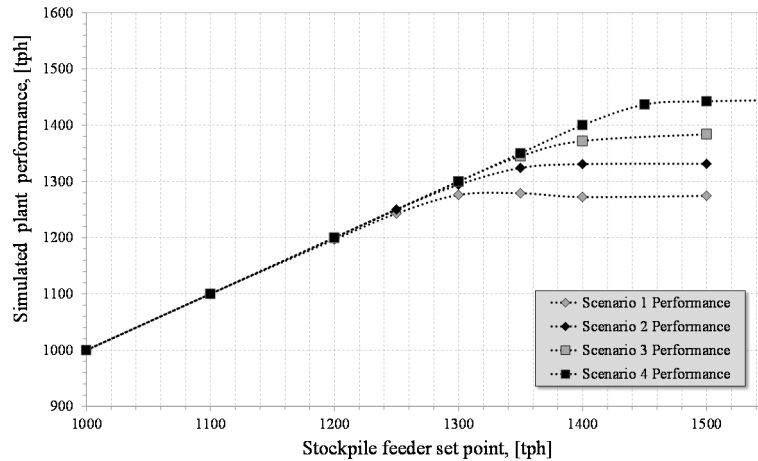

Figure 43. Average plant performance for different feed rates and plant configuration.

7.1.2 EMPIRICAL RESULTS

The empirical experiment of the scenarios gave a promising indication of the fidelity of the simulation, see Figure 44. By running Scenario 1 and Scenario 2 where the CSS of crusher 1 was reduced from 65 mm to 50 mm the overall plant performance increased by 4.9 %, from 1291 tph to 1340 tph compared to 4.7 % simulated. When reducing the capacity of crusher 1 by running the crusher at a smaller CSS the overall plant performance was increased. By running crusher 1 with a smaller CSS the rock material was crushed more in the initial pass and less material was recirculated to crusher 3.

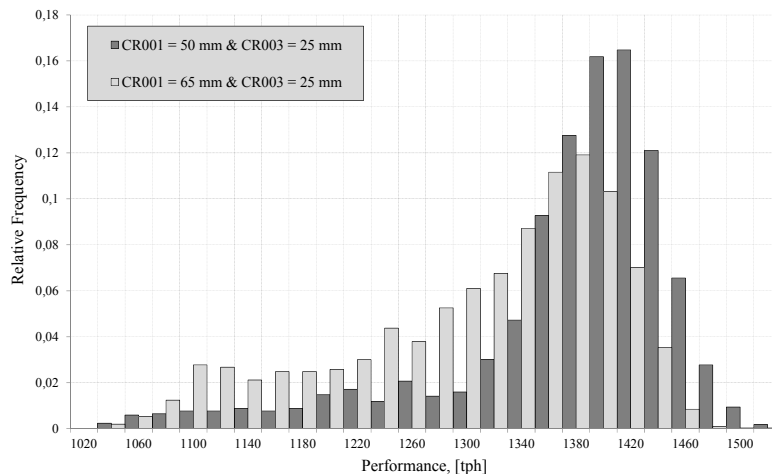

Figure 44. Plant performance for two different CSS of crusher 1 (CR001).

7.2 USER ACCEPTANCE TESTING

The aim of Paper F was to implement a dynamic simulation platform to support future debugging and tuning of an APC algorithm.

The objective of the study was to perform a visual verification of the start-up sequences of the plant and simulate different operating conditions with an offline version of the APC in a third party software. The implementation was a part of user acceptance testing of the simulation platform to verify that simulated system performance corresponds to the existing process performance in terms of process performance and fluctuation. The user acceptance testing was performed together with control engineers working with the existing process.

This builds on previous dynamic modelling work done in Paper C, Figure 40. The work was focused on system identification and the implementation of the APC algorithm in the dynamic plant model. The dynamic model of the plant was connected to the control system via OPC server and the response of the model validated against the behaviour of the plant. The system structure is illustrated in Figure 45.

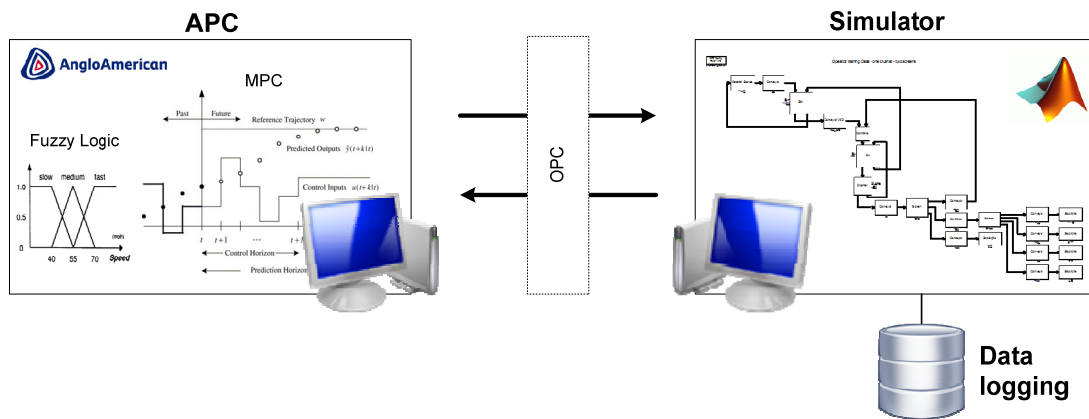

Figure 45. System structure for the implementation.

The step-time of the simulation was synchronized to the control system and ran at 10 times real-time for enabling observation while the simulations were running. An in-house developed HMI was used to observe the process during simulations.

7.2.1 SIMULATION RESULTS

The process simulation was run for 8 hours while under the simulation period no external disturbances were included. Between each simulation the simulation conditions were changed slightly to assess the response of each run, visual validations were performed with an experienced control engineer. Figure 46 illustrates the change in mass flow into the circuit (a), the mass flow on the conveyor after the crushers (b), the mass flow for the circulating load (c) and mass flow out from the circuit (d). For this period the plant average performance was at 1455 tph while the set point for the plant was at 1500 tph.

The modelled plant responded accurately to the implemented APC with some smaller process fluctuation according to visual comparison with the existing process. Running process simulation prior to commission of production processes is generally considered to increase reliability of the process and speed up the ramp-up time needed to reach predicted plant performance. An engineering support tool would also create a more efficient working procedure.

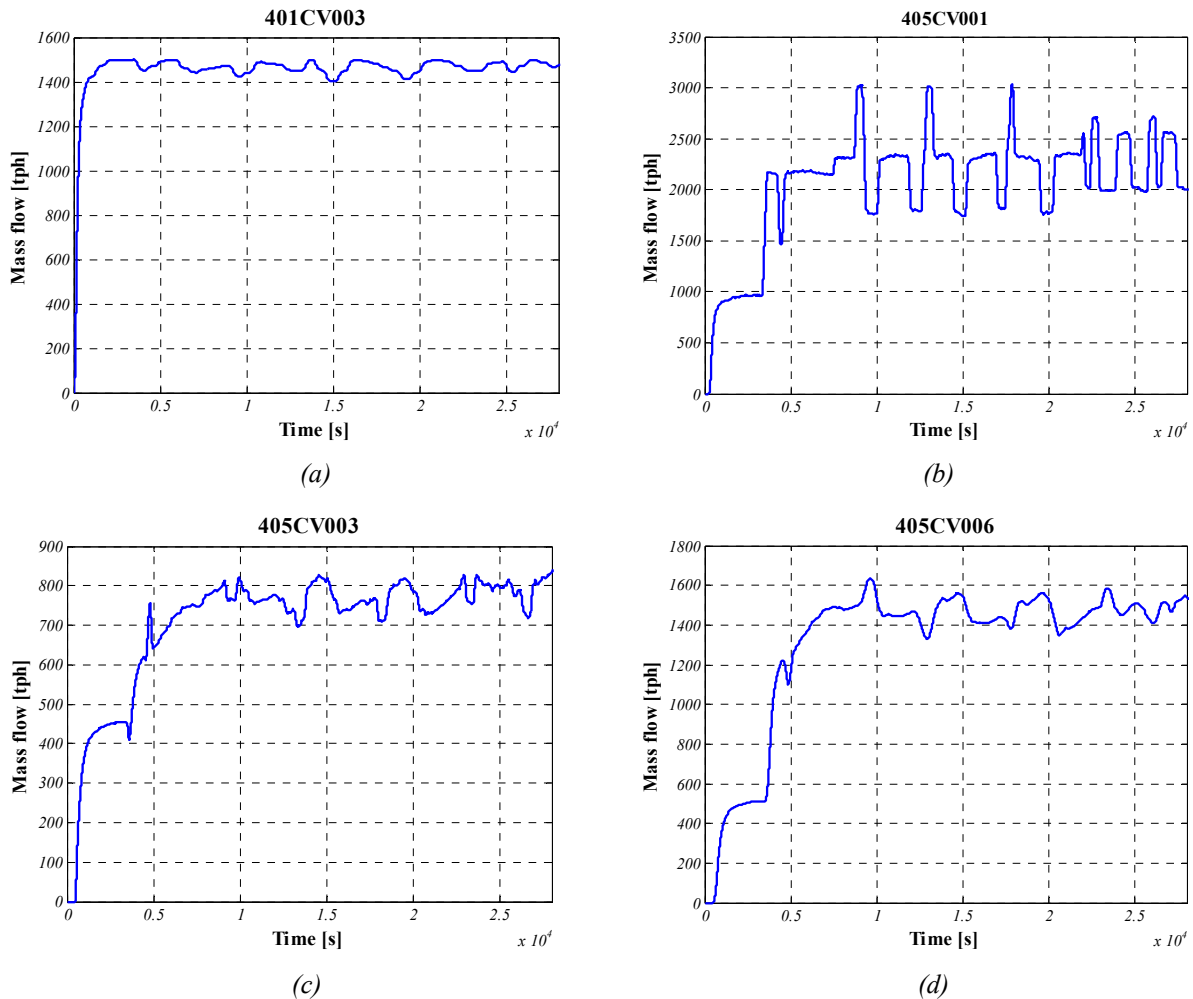

Figure 46. Data from the process simulation, mass flow into the circuit section (a), the mass flow on conveyor after the crushers (b), the mass flow for the circulating load on conveyor (c) and mass flow on conveyor out from the circuit (d).

7.3 SYSTEM STABILITY

A process is never under constant load and variations in the feed will change the performance of the process. In Papers A, C and H the particle size distribution from the feed was varied to evaluate the performance under different conditions. In Paper H the aim of varying the feed size distribution was to evaluate process robustness and ability to maintain a high process performance while operating at a constant CSS, as illustrated in Figure 32. The incoming feed was described by the Swebrec function, Eq. 5.25, with a constant slope factor b and linear incremental increase by the top size (x_{max}) and 50 % particle passing size (x_{50}).

7.3.1 SIMULATION RESULTS

The selected process unit parameters were applicable for around the original feed size distribution and below. The highest process performance was registered at 8 % increase in particle size distribution, Figure 47. However, at 10% larger feed size distribution the crusher 1 violated maximum pressure limit, resulting in an increased CSS for larger size distributions.

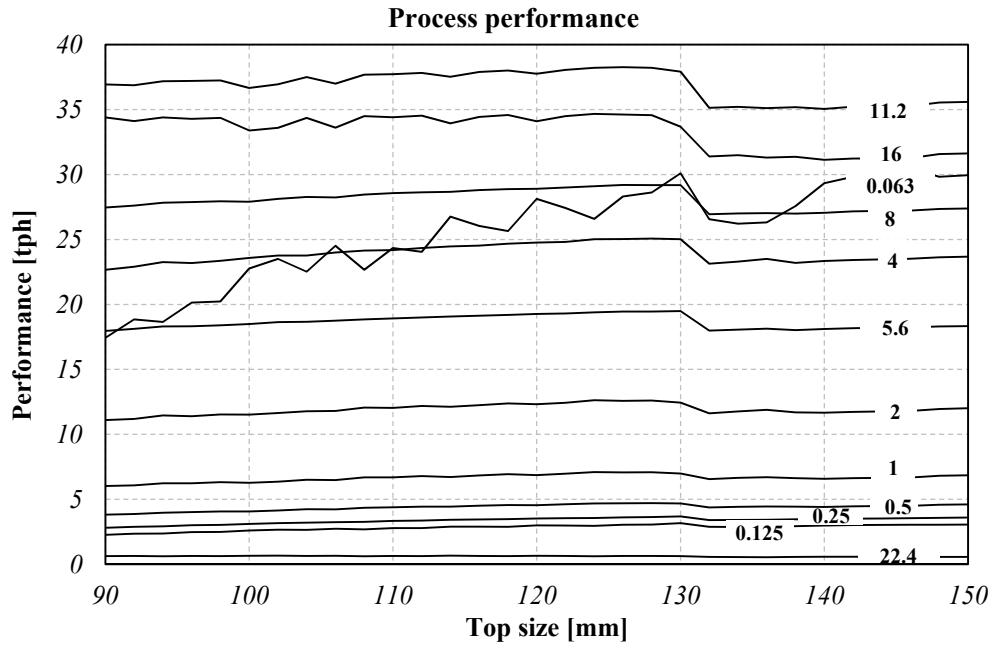

Figure 47. The process performance during different feed size distribution.

A crushing process is never under constant conditions for a long period. In order to assure high productive operation a robust process needs to be configured. This means the process is capable of handling change without losing too much efficiency. A process need to be able to handle variations in particles size distribution and in material properties without drastic effects. Controlling the process actively can have major benefits when it comes to increasing process robustness, availability and utilization.

8 PROCESS OPTIMIZATION

The aim of this chapter is to:

- *Describe the optimization of control algorithm.*
- *Describe the optimization of a crushing operation.*

Optimization implies the selection of best possible combination of design variables x to minimize the defined performance function $f(x)$ with regards to set inequality $g_i(x)$ and equality constraints $h_i(x)$. Formulated in a negative null form in Eq. 7.1 [98].

$$\begin{aligned} & \underset{x \in P}{\text{minimize}} && f(x) \\ & \text{s.t.} && g_i(x) \leq 0 \\ & && h_i(x) = 0 \end{aligned} \tag{7.1}$$

There are multiple aspects of the process and production that can be improved in order to drive the process to an optimum performance. A well-tuned regulatory controller with an appropriate supervisory controller should drive the process to an optimum. The process however is time dependent, i.e. what is optimum at one point is not necessarily optimum later. The production should therefore be managed accordingly.

In the following sections the optimization results from Papers D and H are presented. The purpose of the simulations was to present methods for optimizing different aspects of the process. This includes optimizing the step changes in a real-time optimization algorithm to achieve higher production rate in Paper D and appropriate selection of unit configuration, calibration routine and maintenance approach in Paper H for optimum process performance

8.1 CONTROL OPTIMIZATION

In Paper D tuning of the FSM control parameters was performed to enable faster localisation of an optimum production of aggregates. The FSM is used for selecting appropriate ES for the crusher in order to achieve optimum performance. A GA was used to locate optimum control parameters within a given interval. As discussed in Section 6.2 the algorithm parameters are selected manually (ΔES^+ , ΔES^- and LongTime). At the selected crushing plant, Figure 48, these parameters were set to:

- $\Delta ES^+ = 60$ rpm
- $\Delta ES^- = 60$ rpm
- LongTime = 480 sec

The modelled plant is a tertiary crushing stage in an aggregates quarry, which also has been studied in Paper A. This particular plant is equipped with a frequency converter which enables control of the ES of the crusher by altering the frequency of the motor. This crushing stage is designed with a Metso Nordberg HP4 cone crusher and two triple decked screens which produce products ranging from 0-2 mm up to 16-22 mm, the modelled plant is illustrated in Figure 48. Incorporated into the plant model is a frequency controller model, in which the algorithm for the FSM was implemented.

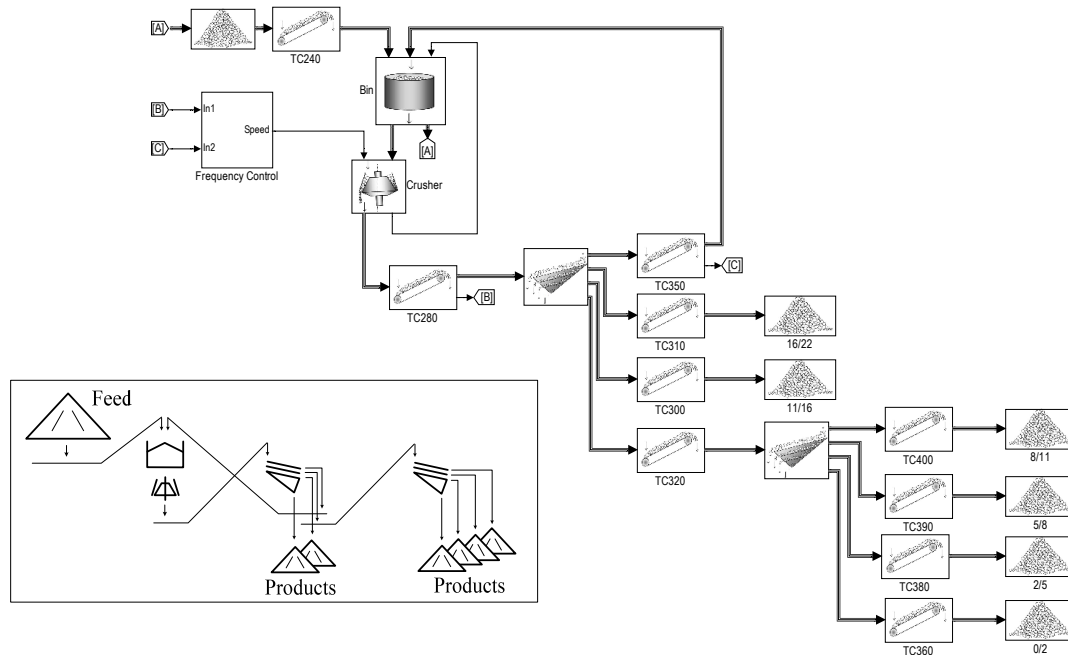

Figure 48. The modelled aggregates process and the frequency controller model in Simulink. A simplified layout of the plant is shown in the embedded picture.

8.1.1 CONTROL OPTIMIZATION RESULTS

Simulation results from running the process with the existing settings are illustrated in Figure 49 while the simulation with the optimized parameters is illustrated in Figure 50. The mass flow is shown in the upper graph and the speed set point is shown in the lower graph. The process was simulated for 12000 s which is approximately the time between each calibration and a disturbance was initiated at 6200 s to represent a short stop in the incoming feed rate. The optimum solution found is shown in Table 2.

Table 2. Optimum solution for the step changes in speed.

Variables	ΔES^+	ΔES^-	LongTime
Limits	20-100 rpm	20-100 rpm	300-1800 s
x^*	91 rpm	48 rpm	544 s

By optimizing the step change for the frequency converter a theoretical increase in production is possible. When comparing the current manually selected parameter against the optimized parameters, shown in Figure 49 and Figure 50, an increase of 0.5 % was estimated. It must be kept in mind that these 0.5 % add on to the manually tuned algorithm which gave about 5 % improvement to the process [12].

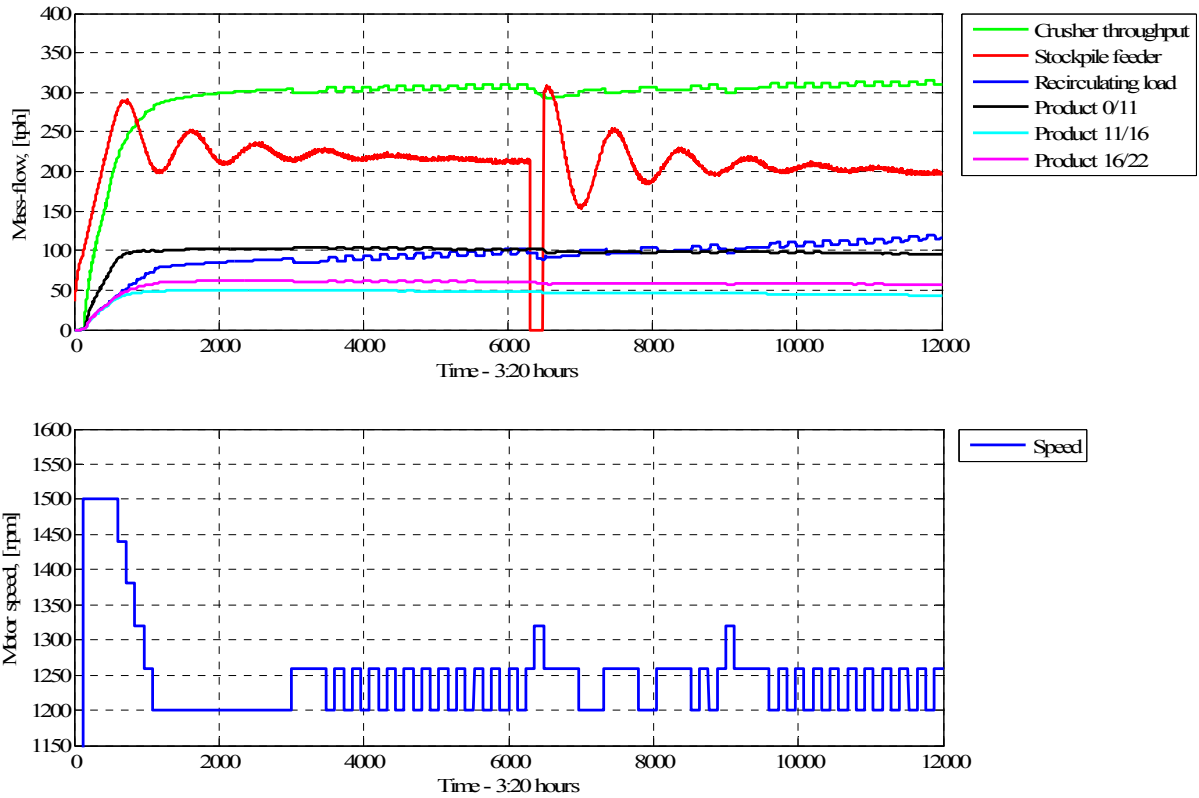

Figure 49. Simulation results with existing settings. The upper graph illustrates the mass flow on different conveyors while the lower one illustrates the change in ES set point during the simulation.

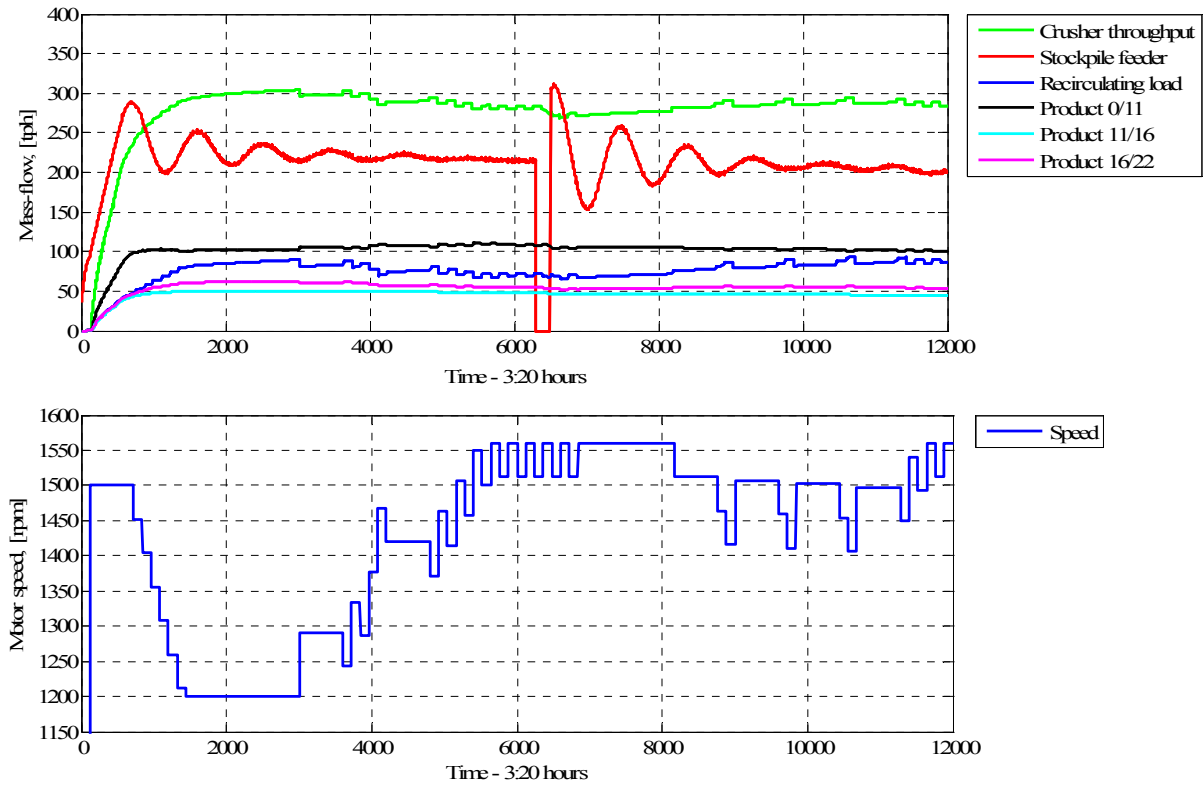

Figure 50. Simulation results after the optimization. The upper graph illustrates the mass flow on different conveyors while the lower one illustrates the change in ES set point during the simulation.

8.2 OPERATION OPTIMIZATION

The changes within the crushing process can be considered to be probabilistic or deterministic depending on the phenomenon. In the case of instant failure the event will have a certain probability of occurring and severity. Deterministic events are planned and scheduled such as breaks, shifts, and maintenance which aim to maintain a reliable and productive process. The characteristics of the consequences of an event will depend on the condition of the process, how the process is operating and how it is managed.

The aim of Paper H was to model, simulate and analyse these discrete phenomena that can cause the process to alter performance due to changing conditions over a long operating period. A novel method for combining discrete probability simulations with time dependent simulations for optimizing the process was presented.

The framework of this study is focused on integrated discrete event based and continuous time based models. This is achieved by running a probabilistic discrete event simulation to provide an input into a continuous time based crushing plant model that represents a conceptual closed-loop circuit configuration containing a feeder, bins, conveyors, crushers and a screen, as shown in Figure 51.

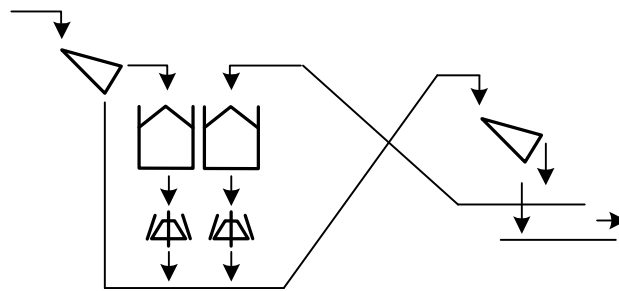

Figure 51. A closed loop secondary crushing circuit.

The DES represents the events in the process that can only change at a discrete point in time. Each event has specific attributes that determine duration of each event or activity. All DES models are considered to be mutually exclusive events. Events such as upstream, downstream and maintenance were given static deterministic behaviour, while mechanical failure will be stochastic and determined by the selected maintenance strategy.

The production simulation was given three different probabilities of mechanical failure: low, medium and high risk, see the illustration of the low and high risk in Figure 52. This will depend on how the operators maintain the process. For a preventive maintenance strategy large time and cost is spent on changing wear parts and adjusting the processes during predetermined service intervals with low risk of failure. During corrective maintenance however, less time is set up for service intervals and higher failure rate since the equipment is not changed until it breaks or is close to failing. An optimum solution is usually a combination of both strategies [99] since frequently changing wear parts prematurely and process stops due to unforeseen equipment failure are both detrimental for the process efficiency.

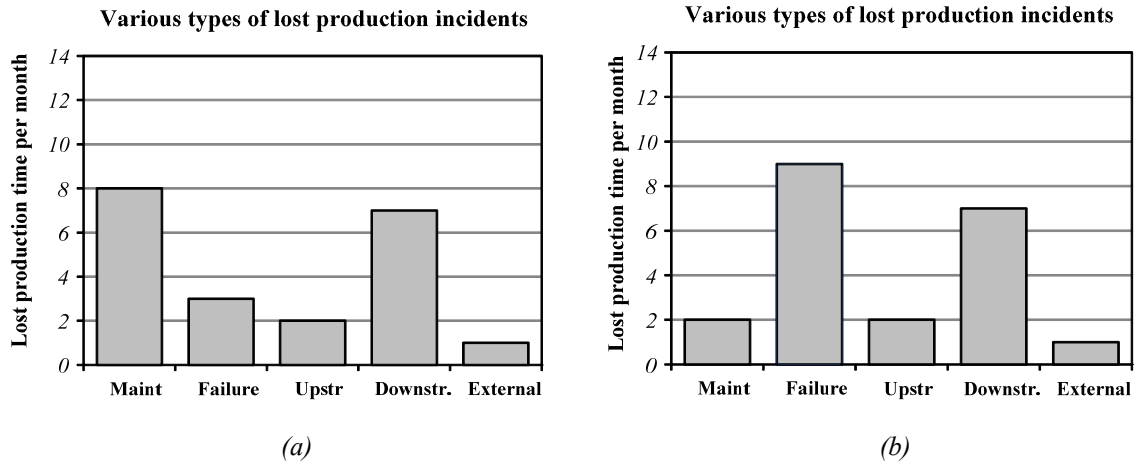

Figure 52. Illustration of the downtimes for preventive (a) and corrective maintenance (b).

Mechanical failures in the process are modelled as stochastic events with probability of failure as a function of maintenance. The three different failure modes were modelled as stochastic events depending on the severity of the failure. Short breakdowns that cause a DT of 30 min – 2 h were modelled with a Weibull distribution, Eq. 5.10. Medium long failures that take 2 – 4 h and long breakdown that take 4 – 12 h were modelled with an Exponential distribution, Eq. 5.11 and Figure 53. Each failure has a set WT of 15 min, which includes detection time and the time it takes to arrange needed maintenance.

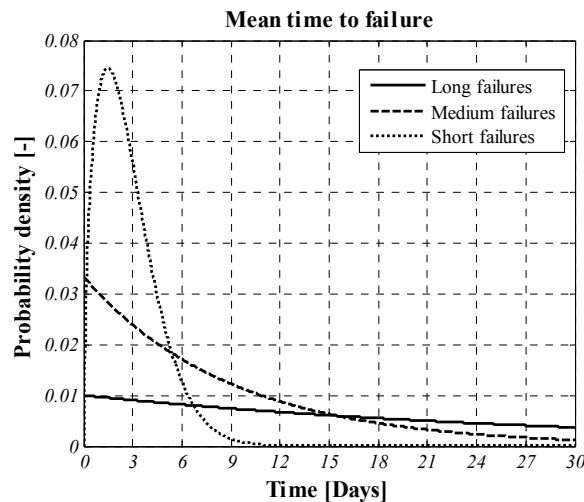

Figure 53. The different probability densities for failures.

The task was to optimize the production of sub 15 mm product ($\dot{m}_{Product}^*$). Variable x is a vector of design variables while p is a vector of fixed parameters for the plant model, Eq. 7.2. Inequality constraints include: the smallest CSS, the grizzly aperture and the crushers pressure limit. The second screen aperture, crushers' ET and ES are treated as equality constraint.

$$\max_{x \in P} \dot{m}_{product}(x) \quad (7.2)$$

8.2.1 OPERATIONAL OPTIMIZATION RESULTS

The average throughput from the circuit for 24 hours was 406.0 tph with standard deviation of 71.0 tph when no wear was estimated. The results from the first iteration are shown in Table 3. The second iteration included the wear rate in the crushing chamber which was set to constant. Each calibration was estimated to take 10 min and 50 hours of production was simulated. The average throughput from the circuit was 375.0 tph with standard deviation of 101.9 tph. The results from the second iteration are shown in Table 4.

Table 3. First optimization iteration – 8 hours base case scenario with no wear or events.

Variables	Primary screen	Crusher 1	Crusher 2
Limits	10-50 mm	20-40 mm	10-30 mm
x^*	Apert. – 20 mm	CSS – 28 mm	CSS – 19 mm

Table 4. Second optimization iteration - 50 hours with calibration.

Variables	Crusher 1	Crusher 2
Limits	2-50 h	2-50 h
x^*	Cal – 11054 s	Cal – 21656 s

Calibrating the crushers is essential in order to keep the process operating at the highest possible throughput. The difference in Overall Equipment Effectiveness (OEE) by calibrating the crusher with 10, 20 and 30 hours between calibrations (TBC) or at 20 hour intervals with continuous adjustment to keep a constant pressure is illustrated in Figure 54. The OEE for 10 hour TBC was calculated at 68.6 %, 66.9 % for the 20 hour TBC, 65.3 % for the 30 hour TBC and 71.4 % for the 20 hour TBC with pressure control. As illustrated in Table 4 the optimum calibration interval for Crusher 2 was around 6 h. Frequent calibrations will keep the crusher at a more stable load. Infrequent calibration will however increase the pressure distribution within the crusher chamber. Adjusting the crusher continuously can increase the performance of the crusher by 4.1-9.3 % instead of passively operating the crusher.

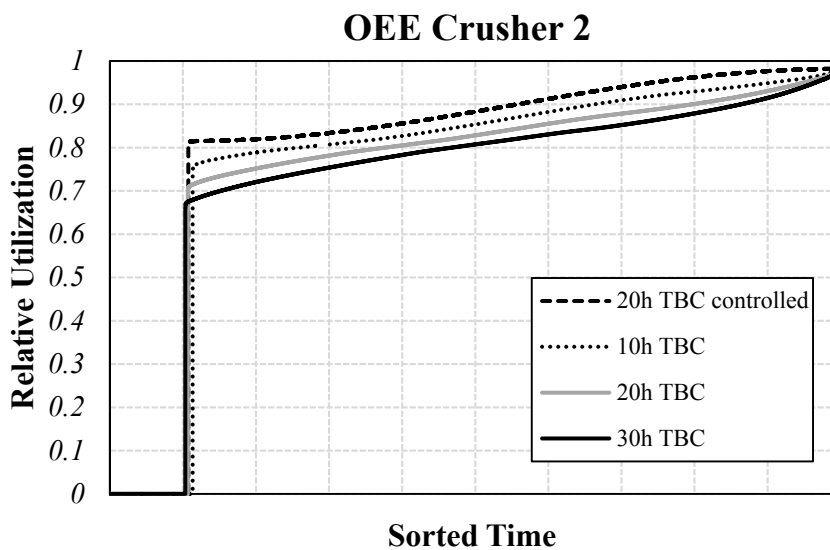

Figure 54. The difference in the crusher’s utilization if calibrated with 10, 20, 30 hour intervals or with 20 hour intervals while operating at a constant load.

9 OPERATOR TRAINING

The aim of this chapter is to:

- Describe the approach to operator training with dynamic simulation.
- Introduce a performance evaluation of operator performance.

Operators are responsible for managing the process in order to obtain a stable production of high quality products and high throughput. The operator's capability in making fast and effective decisions is therefore important. Operator training is often a manual process which is conducted by a verbal interaction between an experienced operator and an inexperienced operator. The operators' cognitive ability in detecting and analysing information from the process can therefore be limited for a novice operator. In Paper E and Paper G the aim was to develop a web based operator training environment with dynamic and discrete event simulation to support operators' cognitive capabilities.

9.1 SYSTEM STRUCTURE

The system structure utilized is a three-tiered distribution: Presentation layer, Application layer and Data management layer as illustrated in Figure 55. The presentation layer is a Thin-Client architecture where the operator or supervisor can access the HMI on a client's PC without an installation of an additional software. By using a standard web browser the operator and supervisor can access production reports, HMI graphics, historical trends and alarms in real-time from anywhere.

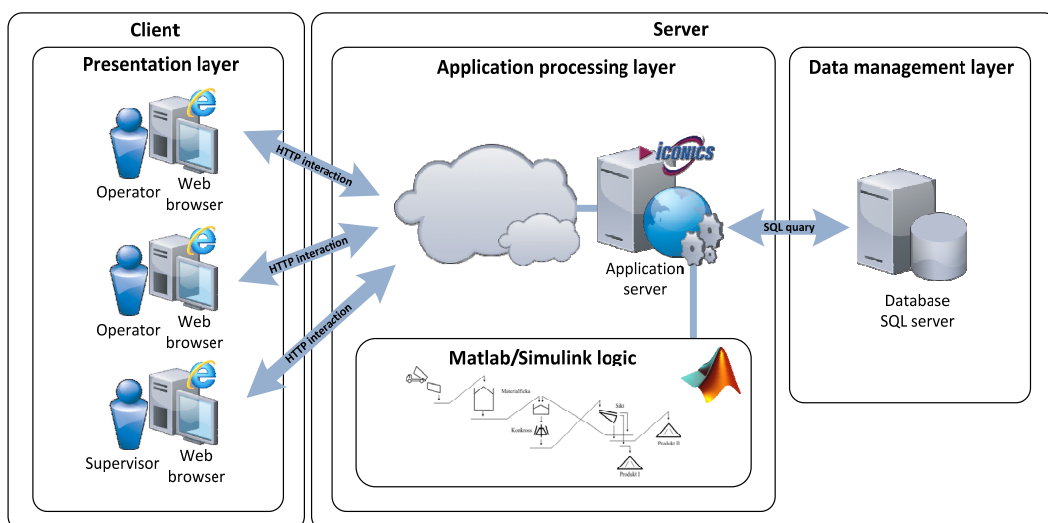

Figure 55. A schematic view over the three-tier application structure.

The process logic of the operator training is within the application process layer. Simulink runs continuous and discrete simulations and the output is dependent on the operator’s setup of the process and his interaction with it.

The data management layer allows for data storage of selected OPC tags with a SQL server. This enables information transfer of historical trends between the HMI and the Simulink model.

The HMIs were developed in ICONICS GENESIS 64 which is a Windows based application, see Figure 56. Three different process layouts were created in Paper G. The process layouts aimed to represent a mobile aggregates application, a stationary two stage aggregates application and a mining application.

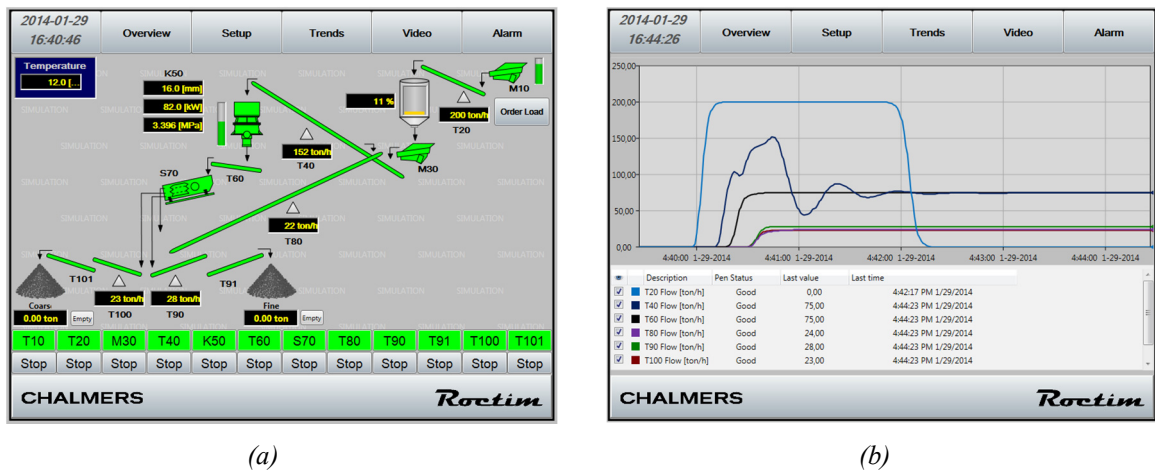

Figure 56. An overview interface developed to illustrate the status of the process (a) and process data display page (b) created for visualizing process data.

9.2 USABILITY STUDY

A usability study was performed to evaluate simulation performance, HMI arrangement and selected process tasks. The tasks were divided up into specific moments where the participants interacted with the process simulation to be able to evaluate the simulation and the HMI arrangement. The study was divided up into the following sections:

- Navigating the display
- Setting up the processes with regards to set quality requirements for:
 - Particle size distributions
 - Shape
- Manually operating the processes
- Automatic regulatory controllers
- Real-time Optimization
- Handling of disturbances
- Calibration routines
- Troubleshooting alarms

The participants started by selecting an appropriate setup for the process to produce 11/16 product according to Gc80/20 requirements [87], given a certain crusher performance, shown in Figure 57.

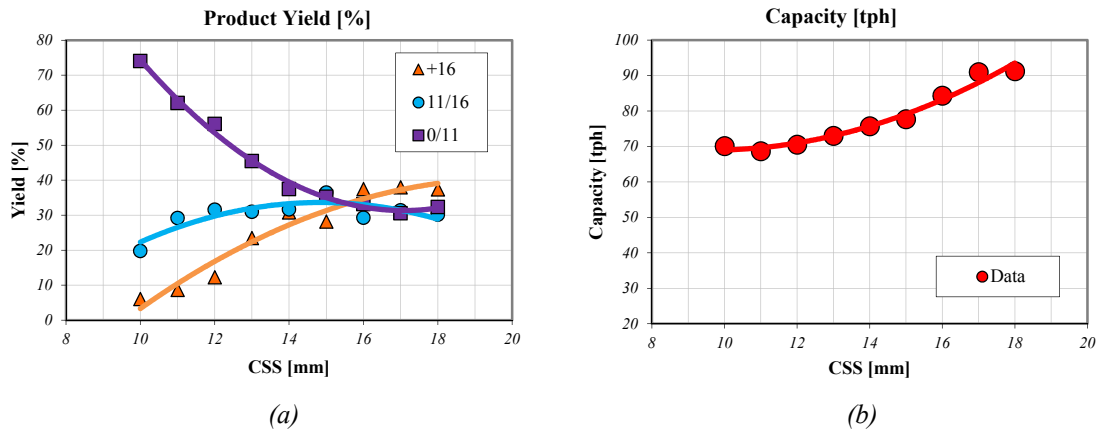

Figure 57. Particles size distribution (a) and capacity (b) under different CSS. Data collected from a H36 cone crusher.

9.2.1 SIMULATION RESULTS

The participants were instructed to operate the process manually and maintain stable production for a specific time period by adjusting the feed rate into the circuit, example shown in Figure 58. T40 being the circuit feed rate and T60 is the crusher throughput. By operating the process with the automatic regulatory control the participants adjusted the set point for the PI controller, instead of trying to maintain constant level in the crusher manually. In Figure 59 a result from an imposed disturbance is shown which caused the mantle to move down and increase the CSS at time 3200 s and up again at time 3350 s. Fluctuation on T40 are caused by the PI controller and the change in T60 is due to changed CSS.

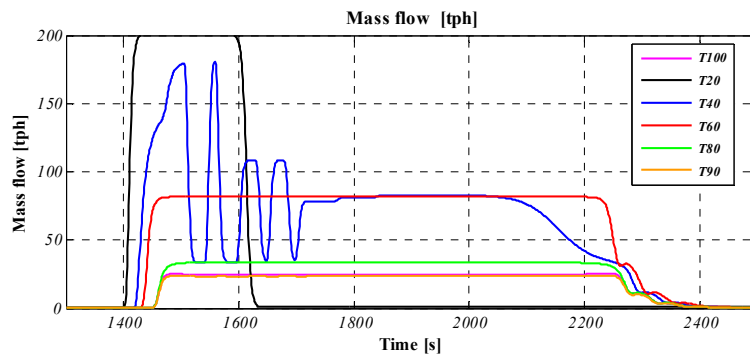

Figure 58. Mass flow manually stabilized by altering feeder frequency.

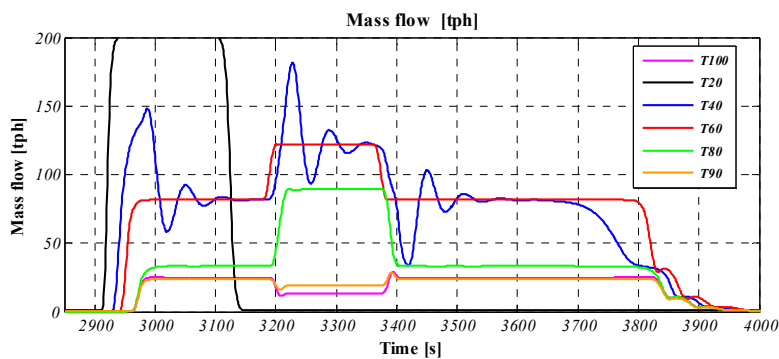

Figure 59. Operating the process with the PI controller active and adjusting CSS.

9.3 OPERATOR EVALUATION

Each group was allowed to vary the feed rate into the circuit, the CSS on the crusher and the apertures on the screens during manual operation of the process. The participants were instructed to find the best possible solution for their capabilities by reading the crusher's performance map in Figure 57 and evaluating the process during operation. A performance function was formulated to evaluate the operators' performance shown in Eq. 9.1.

$$Performance = \frac{m_p (1 - \bar{q}_{shape}) \sum_{t_1=0}^{t_2} (t_{psd})}{t_{total}} \quad (9.1)$$

The variable m_p is the total amount of material produced during the exercise while q_{shape} and t_{PSD} are product quality when it comes to the particle shape and the amount of over- and undersize. The development of the amount of undersize during the training period is illustrated in Figure 60. A penalty function was formulated to estimate the reduced performances of quality requirements where the set requirement was violated. With a performance function the operator performance during the training can be assessed and the improvement over time evaluated.

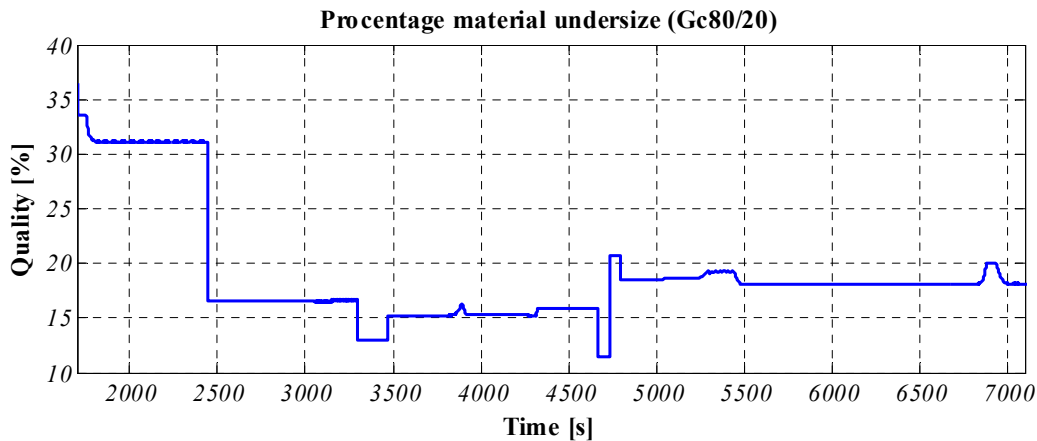

Figure 60. Percentage oversize in the product.

During the usability studies a number of different aspects appeared regarding the arrangement of the simulation based operator training. Aspects such as: direct feedback regarding the quality of the product which is important for the operator to evaluate their performance, understanding the importance of process optimization for process efficiency, increasing process awareness in a complex system and designing the process layout in the HMI in a way that minimizes mental load on operators. The information collected during the usability study gave valuable feedback regarding the development of a web based operator training environment and how to evaluate operators' development.

10 DISCUSSION & CONCLUSIONS

The aim of this chapter is to:

- *Present the most important conclusions drawn in this thesis.*
- *Discuss the validity of the research.*
- *Answer the research questions stated in Chapter 2.*
- *Discuss the future work.*

The aim of this work was to understand how crushing plants perform under different conditions over time and to develop methods and tools for improving plant operation and production yield. During the development of the simulation platform different applications areas were tested for the implementation of the dynamic simulations.

10.1 GENERAL

Dynamic simulation of production processes has the ability to provide the user with in-depth understanding about the process behaviour and response. The details provided are usually not available with traditional steady-state simulations. However, the purpose of the simulation needs to be clear in order to obtain relevant information regarding the process.

As depicted in Figure 14 in Chapter 5 there are a number of factors that can affect plant performance. How some factors affect the process is clear, for example changing the aperture size on a screen will give a different cut point for the mass flow. However, other factors are more difficult to interpret and predict, such as feed material variations, unit failures and operator decisions.

Plant performance is not only affected by the selected production units and changes in the material properties but also by the configuration of the units and the applied control strategy. In a circuit with parallel flows the discrete operation of different units can cause the process to become unstable and in some cases lock itself during an overload. In Paper C it was demonstrated that a plant reaches performance saturation under a specific load. By simulating and evaluating process modification the plant performance could be increased. The empirical test revealed lower process variation and higher process throughput with an improved unit configuration.

One of the main sources of dynamics within the process is caused by material flow and material handling in bins. In Paper B, C and Paper F a large proportion of the reduced process performance originated from inadequate material handling. If not simulated properly multiple unexpected operational issues can occur such as process fluctuation and reduced unit performance.

Process performance will change during operation due to wear in production units (as illustrated in Paper A and H). If left unattended the performance will be reduced. To compensate for wear production units need to be maintained, calibrated and adjusted regularly. However, during each stop for correction the process performance is reduced and process variation is increased, since the process is not producing a product during that period. The choice between preventive and corrective maintenance is a balance of costs. Change of a wear part prematurely involves increased cost for the production since a part may have longer operational time left however, with more controlled DT. Waiting until the parts are worn out or broken can drastically reduce the productivity of the plant. Plant operators need to be attentive to the condition of the process and prepared for sudden failures.

Process optimization is an important issue for every process and organisation where the focus needs to be on maximizing the value for the customer while minimizing the used resources over time. In Paper D and Paper H a systematic approach to optimizing different aspects of the process was illustrated. Optimizing the process entails correct parametric configuration of the production units to maximize throughput, tuning and optimization of the control algorithm, the regulatory and supervisory controller, selecting appropriate operational approach, selecting appropriate maintenance strategy and operators' commitment and understanding of the process.

How the information and where the information is presented is essential for operators' cognitive capability. The interface that the operator has towards the process should support the operator in detection, analysis, action and evaluation of the process, not increase the mental load. Too much information on a small display can have negative effects. By performing operator training, the operators' capability in reacting to changes in the process increases and becomes more effective. With an operator training simulator the operator is able to interact with the process without risking any potential damage to the actual equipment, thus providing the operator with valuable hands-on experience.

10.2 VALIDATION

Validity concerns the integrity of the conclusions that are generated from the conducted research [34]. Validation of the research is the process of determining the degree of fidelity of the system from the perspective of its intended purpose [35].

Structural validity refers to the system's background information which is the foundation for the constructed system and the appropriateness of the selected examples to illustrate the problem. With each study, in the appended papers, the aim has been to solve an existing and generic industrial problem regarding process operation, process optimization, process control and operator training. Every problem in the process discussed in this thesis has a generic form and can have either high or low influence on the process. The example processes and cases used in this thesis are aimed to emphasize these particular phenomena.

Theoretical structural validity has been achieved through the use of standardized and accepted models as the fundamental base for size reduction and separation. Each model is complemented with additional sub-models which enable an estimation of the transition from one state to another in a time dependant environment. These complementary sub models have been adapted from applied models from related fields within minerals processing, powder technology, control theory and chemical engineering to capture the process dynamics.

The performance validity states that the simulated system produces satisfactory accuracy and that the results are useful and consistent within its domain of application. Each study has been aimed to capture the dynamics that can cause the process to alter performance. In Paper C the estimated performance was compared to an empirical experiment for similar condition for

performance validation. In Paper F a user acceptance test was used and the process adjusted until it gave an acceptable response. In Papers E and G a usability study was performed for operator training to provide feedback for further development. Papers A, B and H are focused on capturing a specific aspect that causes the process to change state. Papers E, G and H more conceptual than Papers A, C, D, and F that are aimed to mimic specific process plants.

Each paper was based on sampled data from specific plants or arbitrary processes with similar production units and configurations. Taking samples from a process however only provides a snapshot of the process at a particular place and at a particular time. According to Åström [97], a model is only valid at the time the experiment is performed. If the process dynamics change with time, it may not be valid at a later time. Empirical models are dependent on empirical data from a particular process and production unit to accurately represent the system. These models have a weak congruence since they need to be adjusted for every application. Mechanistic models are however based on the Newtonian mechanics within the unit and do often have a stronger congruence. In Papers A-F the models were empirical while in Paper H and I the simulation is based on the mechanistic models developed for cone crushers and screens.

10.3 ANSWERS TO RESEARCH QUESTIONS

The following answers are given to the research questions stated in this thesis:

RQ1. What methods and techniques can be used to satisfactory simulate dynamic crushing plant behaviour?

Traditional steady-state simulations are not adequate to represent time dependent behaviour properly. However, there have been a number of attempts to compensate for the lack of time perspective in steady-state simulation in order to represent the dynamics. In Svedensten et al. [16] the effect of wear and process variation on production was estimated by running steady-state simulation together with Monte Carlo simulation, which was used to estimate the performance distribution of the plant. In King et al. [100] the step changes in the process were evaluated by running multiple steady-state simulations in a sequence.

Dynamic simulation is defined in this thesis as continuous simulations with sets of differential equations together static equations to reproduce the dynamic performance of a system. The fundamental parts of dynamic systems are described in Chapter 5 - Modelling of Crushing Plants. Different modelling principles can be applied to estimate the different dynamics in a system, such as: first principle models, state-space models, transfer functions and differential equations. The material flow in a dynamic system is not constrained by the instantaneous mass balance in contrast to steady-state simulations for example. Instead it follows the principle of conservation of mass, which is described with a differential equation in Eq. 4.6.

When simulating long term conditions, the implementation of DESs is necessary in order to obtain reliable results. With a DES the simulation is not continuous any more. Instead the change in state is initiated at a specific time, making it discrete. With SimEvents a discrete event perspective can be added in the modelling environment making the plant simulation a hybrid one i.e. a combination of discrete and continuous simulation.

Different platforms exist that support the modelling of dynamic systems. During the work in this thesis two different platforms have been used and validated, SysCAD (Kenwalt) and Simulink (Mathworks). Both platforms are highly capable of simulating the dynamic behaviour that occurs in a crushing plant. Even though SysCAD is able to deliver a built-in equipment library Simulink provides more flexibility and better integration capabilities of the modelling environment in the development of a dynamic simulator.

RQ2. What physical principles and phenomena can cause dynamic behaviour in crushing plants?

Multiple factors affect the performance of a crushing plant, according to Figure 14. On a production unit level the internal dynamics within the fundamental level of each unit are essential for achieving high fidelity process simulations, Figure 15. Accurate representation of the unit and process level can be achieved with a bottom-up fundamental approach to the modelling when the models structure has been defined. Such has been the approach in the crushers in Paper H, screen in Paper I and material handling in Papers B, E and F.

The process is affected by gradual and discrete changes. The changes are usually caused by a change in operating conditions or unit condition. Wear on components happens gradually over a long time perspective while the unit response has a much shorter time constant. Changes in set points, calibrations, interlocks and failures are examples of factors that create discrete changes in the process. How the process responds to gradual and discrete changes is dependent on the configuration and the characteristics of the each individual production unit. Stochastic and systematic variations also contribute to the dynamic behaviour of the process and should not be neglected as observed in Paper A.

In dynamic simulations the transport and storage of material within time dependent equipment can cause process fluctuation if the design of the plant or the control system is not adequate to keep the process stable. When the material is transported with conveyors between different production units the process experiences a time delay and if the storage capacity is small in the subsequential production unit the control system needs to be able to take that into consideration and regulate the flow in order to keep the process stable. Studying the example in Chapter 7.1, the plant experiences a steady-state operation up to a certain target feed rate, after that the average plant throughput levels out due to process dynamics as illustrated in Figure 61.

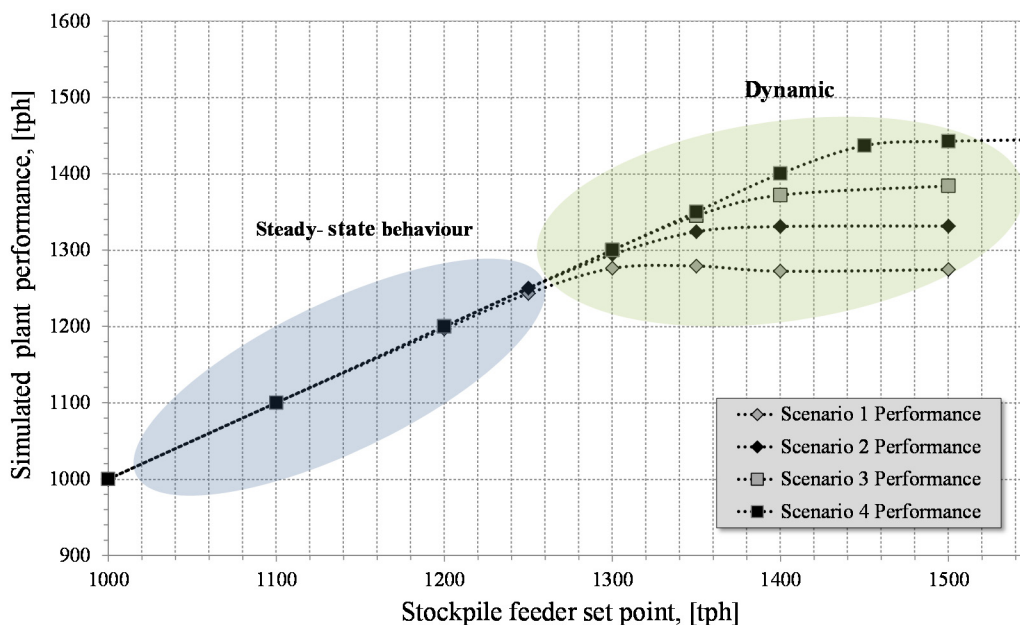

Figure 61. Plant's average production performance. In the blue area the plant operates in steady-state while in the green area the plant experiences fluctuation and limited throughput.

RQ3. What are the main applications for a dynamic simulation platform?

The main areas of application for dynamic simulation for industrial purposes that have been identified in this thesis are:

- Process simulation
- Evaluation of plant design
- Control development
- Process optimization
- Operational planning
- Maintenance planning
- Operator training

In all of these areas the use of dynamic simulation has shown to be essential. How the dynamic simulation is applied varies between each area and also within each area, depending on the general purpose of the simulation.

RQ4. What process related characteristics must be included in the process model to simulate the process performance and achieve useful information?

Which models are used and how the process model is configured is dependent on what the purpose of the simulation is, listed in the previous question. Some applications require higher level of fidelity while others require faster computational time in respect to each other. From a generic perspective the process needs to be able to accurately capture every possible source of dynamics in the process to supply relevant information for the selected purpose.

During operation the process will experience different performance over time. Each production unit may be subjected to substantial wear, changing the performance of the unit and possibly affecting the whole process. To maintain a highly efficient and productive process the process needs to be stopped for maintenance, calibrations and adjustments at regular intervals. The amount of wear is determined by how the units are operated and the material properties. The material properties are not constant but are usually within an interval depending on the source of the material and utilized pre-process. In order to minimize the effects from variation the control system regulates the flow which in turn maintains high throughput and safe operation. The operators are finally responsible for monitoring the process and evaluate if the process parameters need to be adjusted to increase production of a certain product or product quality depending on predefined product requirements, if not taken care of by a supervisory regulatory control system.

RQ5. How can suitable control strategies for crushing plants be developed with dynamic simulations?

The development of suitable control strategies is recommended according to the following path:

- Understand the process
- Identify control and manipulative variables
- Formulate the control objective
- Select appropriate candidates for control strategies
- Design the control algorithms
- Tune the algorithms
- Implement control algorithms in the process model
- Simulate and evaluate plant performance under different conditions
- Compare

Well defined production unit models support the understanding of the process and the identification of what variables can be considered to be control or manipulative variables and how they will affect the process.

The fundamental design and development of a control system starts by defining the control objective. This can be to control a certain level or mass flow within the process. An appropriately designed control system should provide a stable operation, an acceptable response to input commands, be insensitive to system parameter change, minimize steady-state error to input commands and reduce the effects of undesired disturbances [13].

Dynamic modelling is essential when it comes to developing, tuning and evaluation of control algorithms. Tuning can be achieved with a linear approximation of the process around the operational condition as illustrated in Paper H. While evaluating the process performance under different conditions, a complete process simulation with superimposed control algorithm is recommended. This can be achieved either by implementing the control algorithm in the model (Paper B and C) or through a third party software (Paper F).

RQ6. What aspects of using dynamic simulations for operator training should be utilized to improve operators' capability to maintain a safe and productive process?

For operator training, as illustrated in Paper E and Paper G, the operator needs to be able to interact with the process and make process changes in real-time. With a dynamic simulation running in real-time connected to an HMI this becomes possible, thus minimizing the need of interfering with or interrupting the actual production.

The operator needs to be able to select appropriate process parameters from a crusher performance mapping and be aware of the process conditions. The operator needs to understand how the crusher is operated, what are the operational limits of the crusher and its load history. The operator needs to recognize that the performance of the circuit often depends on how fast they can make the necessary decision and adjust the process accordingly.

How the information and where the information is presented is essential for operators cognitive capability. The interface that the operator has towards the process should support the operator in detection, analysis, action and evaluation of the process, not increase the mental load.

10.4 FUTURE WORK

The work presented in this thesis has been focused mainly on modelling and exploratory studies of different applications for implementation of dynamic simulation. With dynamic simulation new applications become possible compared to the use of steady-state simulations, applications such as operator training and control algorithm development. Each application is relatively time consuming to setup. A more easy-to-use graphical user interface and refined model structure would reduce the configuration time.

Cost is the largest drive of the process. Increasing the value of the product and striving to reduce the needed resources is necessary to secure business profit. An aggregates production each product has a different market value while cost of producing these products are directly related to energy consumption, source of energy, wear on components, process selection, human resources and product logistics. In order to optimize the efficiency of the process the cost needs to be clearly defined.

Environmental impact from quarries and mines is an important issue from a sustainable perspective. The material flow carries with it a footprint of consumed energy, hazardous chemicals and water. Estimating the environmental impact for each unit, such as water and oil use, as well energy and resource consumption is essential for estimating the accumulated environmental impact of the processed product.

The development and tuning of a control system is essential for ensuring safe and robust operation while striving for high product quality and high production throughput. There are multiple solutions available for regulatory and supervisory control systems, each with a number of advantages and disadvantages and applicability to certain process configuration. A detailed framework of available solutions for different objectives and configuration with the state of the art from academia and industrial applications would be valuable for future applications.

Operator training needs to be easily accessible and provide useful information for the participants. A site-specific process layout and operational specific aspects could provide the user with relevant information to use in daily operation. Such as how to configure the process with regards to market demand and available product to optimize process profit.

Many of the aspects that were illustrated in the Ishikawa-diagram in Figure 14 have been covered in this thesis. Segregation in bulk material is an operational issue that reduces overall unit performance and can increase localized wear in crushers and screens. Quantifying misaligned feed and segregation at different transfer points can provide a more accurate estimation of the process performance.

The efficiency of crushing and screening processes are essential for a sustainable operation and organisation. Understanding the process and process dynamics opens up for possibilities to improve the production in multiple aspects of the operation. The development of dynamic simulation and its related applications will continue as there is a need for engineering tools to be used both within academia and in the industry.

REFERENCES

1. Blatt, H., R. Tracy, and B. Owens, *Petrology : Igneous, Sedimentary and Metamorphic*. 3rd ed. 2010, New York: W. H. Freeman.
2. Hultkvist, L., *Berg för Byggande*. 2nd ed. 2007, Stockholm: The Swedish Aggregates Producers Association.
3. SGU, *Grus, sand och krossberg 2013*. 2013, Uppsala: Geological Survey of Sweden.
4. SGU, *Bergverksstatistik 2013*. 2013, Uppsala: Geological Survey of Sweden.
5. Wills, B. and T.J. Napier-Munn, *Wills' Mineral Processing Technology: an introduction to the practical aspects of ore treatment and mineral recovery*. 7th ed. 2011, London: Elsevier Ltd.
6. Evertsson, M., *Cone Crusher Performance*, in *Department of Machine and Vehicle Design*. 2000, PhD Thesis from Chalmers University of Technology: Gothenburg.
7. Lee, E., *Optimization of Compressive Crushing*, in *Department of Product and Production Development*. 2012, PhD Thesis from Chalmers University of Technology: Gothenburg.
8. Bengtsson, M., *Quality-Driven Production of Aggregates in Crushing Plants*, in *Department of Product and Production Development*. 2009, PhD Thesis from Chalmers University of Technology.
9. Stafhammar, M.S., *Screening of Crushed Rock Material*, in *Department of Machine and Vehicle Systems*. 2002, PhD Thesis from Chalmers University of Technology: Gothenburg.
10. Johansson, R., *Air Classification of Fine Aggregates*, in *Department of Product and Production Development*. 2015, PhD Thesis from Chalmers University of Technology: Gothenburg.
11. Narasimha, M.a., et al., *A semi-mechanistic model of hydrocyclones - Developed from industrial data and inputs from CFD*. International Journal of Mineral Processing, 2014. 133: p. 1-12.
12. Hulthén, E., *Real-Time Optimization of Cone Crushers*, in *Department of Product and Production Development*. 2010, PhD Thesis from Chalmers University of Technology: Gothenburg.

13. Dorf, R.C. and R.B. Bishop, *Modern Control Systems*. 9th ed. 2001, Upper Saddle River: Prentice Hall, cop.
14. Bainbridge, L., *Ironies of Automation*. *Automatica*, 1983. 19(6): p. 775-779.
15. Ljung, L. and T. Glad, *Modelling of Dynamic Systems*. 2002, Upper Saddle River: Pearson Prentice Hall.
16. Svedensten, P., *Crushing Plant Performance*, in *Department of Applied Mechanics*. 2005, PhD Thesis from Chalmers University of Technology: Gothenburg.
17. Herbst, J., et al., *Mineral Processing Plant/Circuit Simulators: An Overview*. Mineral Processing Plant Design, Practice, and Control Proceedings. Vol. 1. 2002, New York: Society for Mining, Metallurgy, and Exploration (SME).
18. Napier-Munn, T.J., et al., *Mineral Comminution Circuits - Their Operation and Optimisation*. 2005, Brisbane: Julius Kruttschnitt Mineral Research Centre.
19. King, R.P., *Modelling and Simulation of Mineral Processing Systems*. 1st ed. 2001, Oxford: Butterworth-Heinemann.
20. Morrison, R.D. and J.M. Rickardson, *JKSimMet: A Simulator for Analysis, Optimization and Design of Comminution Circuits*. Mineral Processing Plant Design, Practice, and Control Proceedings. Vol. 1. 2002, New York: Society for Mining, Metallurgy and Exploration (SME).
21. Outotec. *Outotec – Virtual Experience Training*. 2015.
22. Honeywell. *Rio Tinto Alcan Gove Improves Operator Training and Startup Time with UniSim*. 2015.
23. MetDynamics. *Operator Training*. 2015.
24. Li, X., M.S. Powell, and T. Horberry, *Human Factor in Control Room Operations in Mineral Processing: Elevating Control From Reactive to Proactive*. *Journal of Cognitive Engineering and Decision Making*, 2012. 6: p. 88-111.
25. Lindqvist, M., *Wear in Cone Crusher Chambers*, in *Department of Applied Mechanics*. 2005, PhD thesis from Chalmers University of Technology: Gothenburg.
26. Crotty, M.J., *The Foundations of Social Research - Meaning and Perspective in the Research Process*. 1998, Australia: Allen & Unwin
27. Williamsson, K., *Research methods for students, academics and professionals*. 2nd ed. 2002, Wagga Wagga: Centre for Information Studies.
28. Kossiakoff, A., et al., *System Engineering Principles and Practice*. 2nd ed. Systems engineering and management. 2011, New Jersey: John Wiley & Sons, Inc.
29. Blanchard, B.S. and W.J. Fabrycky, *System Engineering and Analysis*. 4th ed. 2006, Upper Saddle River: Pearson Prentice Hall.

30. NASA, *NASA System Engineering Handbook*. 2007, Washington, USA: National Aeronautics and Space Administration.
31. Dormand, J.R. and P.J. Prince, *A family of embedded Runge-Kutta formulae*. Journal of Computational and Applied Mathematics, 1980. 6(1): p. 19-26.
32. Chapra, S.C. and R.P. Canale, *Numerical Methods for Engineers*. 6th ed. 2010, New York: McGraw-Hill.
33. Shampine, L.F., *Interpolation of Runge-Kutta Methods*. SIAM Journal on Numerical Analysis, 1985. 22(5): p. 1014-1027.
34. Bryman, A. and E. Bell, *Business research methods*. 2nd ed. 2007, Oxford: Oxford University Press.
35. Oberkampf, W.L., T.G. Trucano, and C. Hirsch, *Verification, Validation and Predictive Capability in Computer Engineering and Physics*. Applied Mechanics Reviews, 2004. 57(5): p. 345-384.
36. Pedersen, K., et al. *Validating Design Methods & Research: The Validation Square*. in *ASME Design Engineering Technical Conferences 2000* 2000. Baltimore.
37. Quist, J., *Discrete Element Modelling and Simulation of Compressive Crushing*, in *Department of Product and Production Development*. 2015, Licentiate thesis from Chalmers University of Technology: Gothenburg.
38. Hofmann, M., *On the Complexity of Parameter Calibration in Simulation Models*. The Journal of Defense Modelling and Simulation, 2005. 2(4): p. 217-226.
39. Rittinger, R.P., *Lehrbuch der Aufbereitungskunde*. 1867, Berlin: Ernst and Korn.
40. Kick, F., *Das Gesetz der proportionalen Widerstände und seine anwendung felix*. 1885, Leipzig.
41. Bond, F.C., *The third theory of comminution*. Trans. AIME, 1952. 193: p. 484-494.
42. Lindqvist, M., *Energy considerations in compressive and impact crushing of rock*. Minerals Engineering, 2008. 21(9): p. 631-641.
43. Walker, W.H., et al., *Principles of Chemical Engineering*. 1937, New York: McGraw-Hill.
44. Hukki, R.T., *Proposal for a Solomonic Settlement Between the Theories of von Rittinger, Kick and Bond*. AIME Transaction, 1962. 223: p. 403-408.
45. Epstein, B., *The mathematical description of certain breakage mechanisms leading to the logarithmic-normal distribution*. J. Franklin inst., 1947. 244: p. 471-477.
46. Whiten, W.J., *The Simulation of Crushing Plants with Models Developed using Multiple Spline Regression*, in *10th International Symposium on the Application of Computer Methods in Mineral Industry*. 1972.

47. Dundar, H., A.H. Benzer, and N. Aydogan, *Application of population balance model to HPGR crushing*. Minerals Engineering, 2013. 50-51: p. 114-120.
48. Whiten, W.J., *Ball Mill Simulation Using Small Calculators*, in *AusIMM proc.* 1976. p. 47-53.
49. Valery, W. and S. Morrell, *The Development of a Dynamic Model for Autogenous and Semi-Autogenous Grinding*. Minerals Engineering, 1995. 8(11): p. 1285-1297.
50. Valery, W., *A model for dynamic and steady-state simulation of autogenous and semi-autogenous mills*, in *School of Engineering*. 1998, PhD thesis from University of Queensland: Brisbane.
51. Tavares, L.M. and R.M. Carvalho, *A Mechanistic Model of Batch Grinding in Ball Mills*, in *XXV International Mineral Processing Congress*. 2010: Brisbane.
52. Newton, I., *Philosophiæ Naturalis Principia Mathematica*. 1687.
53. Evertsson, M. and M. Lindqvist, *Pressure Distribution and Power Draw in Cone Crushers*, in *Minerals Engineering '02*. 2002: Perth.
54. Sbárbaro, D., *Control of Crushing Circuit with Variable Speed Drives*, in *16th IFAC World Congress*. 2005: Prague.
55. Plitt, L.R., *The Analysis of Solid-Solid Separations in classifiers*. CIM Bulletin, 1971.
56. Reid, K.J., *Derivation of an equation for classifier -reduced performance curves*. Can Metall Quart, 1971. 10: p. 253-254.
57. Rosin, P. and E. Rammler, *The Laws Governing the Fineness of Powdered Coal*. Journal of the Institute of Fuel, 1933. 7: p. 29-36.
58. Hatch, C.C. and A.L. Mular, *Simulation of the Brenda Mines Ltd secondary crushing plant*. AIME Transactions Volume 272, 1982.
59. Karra, V.K., *Development of a Model for Predicting the Screening Performance of a Vibrating Screen*. CIM Bulletin, 1979.
60. Lynch, A.J., *Mineral Crushing and Grinding Circuits: Their Simulation, Optimisation, Design and Control* Developments in Mineral Processing. Vol. 1. 1977: Elsevier Scientific Publishing Company.
61. Csöke, B., et al., *Optimization of stone-quarry technologies*. International Journal of Mineral Processing, 1996. 44-45: p. 447-459.
62. Powell, M.S., B. Foggiatto, and M.M. Hilden, *Practical simulation of FlexiCircuit processing options*, in *XXVII International Mineral Processing Congress*. 2014: Santiago.
63. Powell, M.S., et al., *Optimisation Opportunities for HPGR Circuits*, in *11th AusIMM Mill Operators' 2012*. 2012: Hobart.

64. Whiten, W.J., *Models and Control Techniques for Crushing Plants*, in *Control '84 Mineral/Metallurgical Processing 1984*, AIME.
65. Herbst, J. and A. Oblad, *Modern control theory applied to crushing. part 1: Development of a dynamic model for cone crusher and optimal estimation of crusher operating variables.*, in *Proceedings of IFAC symposium on Automation for Mineral Resource Development*. 1985: Queensland. p. 301-307.
66. Sbárbaro, D., *Advanced Control and Supervision of Mineral Processing Plants - Dynamic Simulation and Model-based Control System Desing for Comminution Circuits*. 2010, New York: Springer-Verlag London Limited.
67. Liu, Y. and S. Spencer, *Dynamic simulation of grinding circuits*. *Minerals Engineering*, 2004. 17(11-12): p. 1189-1198.
68. Itävuo, P., A. Jaatinen, and M. Vilkkko, *Simulation and advanced control of transient behaviour in gyratory cone crushers*, in *8th Seminario Internacional de Procesamiento de Minerales*. 2011: Santiago.
69. Ruuskanen, J., *Influence of Rock Properties in Compressive Crusher Performance*. 2006, PhD thesis from Tampere University of Technology: Tampere.
70. Airikka, P., *Plant-wide process control design for crushing and screening processes*, in *Procemin 2013*. 2013: Santiago, Chile.
71. Itävuo, P., et al. *Tight feed-hopper level control in cone crushers*. in *XXVII International Mineral Processing Congress*. 2014. Santiago.
72. Atta, K.T., A. Johansson, and T. Gustafsson, *Control oriented modelling of flow and size distribution in cone crushers*. *Minerals Engineering*, 2014. 56: p. 81-90.
73. Itävuo, P., M. Vilkkko, and A. Jaatinen, *Indirect Particle Size Distribution Control in Cone Crushers*, in *16th IFAC Symposium on Automation in Mining, Mineral, and Metal Processing*. 2013: San Diego.
74. Bolander, A. and S. Lindstedt, *Automation and Optimization of Primary Gyratory Crusher Performance for Increased Productivity*, in *Department of Product and Production Development*. 2015, MSc thesis from Chalmers University of Technology: Gothenburg.
75. Atta, K.T., A. Johansson, and T. Gustafsson, *On-Line Optimization of Cone Crushers using Extremum-Seeking Control*, in *IEEE Multi-conference on System and Control*. 2013: Hyderabad.
76. Huband, S., et al., *Maximising overall value in plant design*. *Minerals Engineering*, 2006. 19(15): p. 1470-1478.
77. While, L., et al., *A multi-objective evolutionary Algorithm approach for crusher optimisation and flowsheet design*. *Minerals Engineering*, 2004. 17(11-12): p. 1063-1074.
78. MathWorks. *MATLAB - Global Optimization Toolbox*. 2015.

79. Box, G.E., J.S. Hunter, and W.G. Hunter, *Statistics for Experimenters - Design, Innovation, and Discovery*. 2nd ed. 2005, Hoboken: John Wiley & Sons.
80. Li, X., et al., *The control room operator: The forgotten element in mineral process control*. Minerals Engineering, 2011. 24(8): p. 894-902.
81. Toro, R., J.M. Ortiz, and I. Yutronic, *An Operator Training Simulator System for MMM Cominution and Classification Circuits*, in *IFAC Workshop on Automation in the Mining, Mineral and Metal Industries*. 2012: Gifu.
82. Toro, R., J.M. Ortiz, and C. Zamora, *An Integrated Simulation-Based Solution for Operator Effectiveness*, in *16th IFAC Symposium in Automation in Mining, Mineral, and Metal Processing*. 2013: San Diego.
83. Andersen, J.S. and T.J. Napier-Munn, *The Influence of Liner Condition on Cone Crusher Performance*. Minerals Engineering, 1990. 3(1-2): p. 105-116.
84. Morrison, R.D. and P.W. Cleary, *Towards a virtual comminution machine*. Minerals Engineering, 2008. 21(11): p. 770-781.
85. Moshgbar, M., R. Parkin, and R.A. Bearman, *Application of fuzzy logic and neural network technologies in cone crusher control*. Minerals Engineering, 1995. 8(1-2): p. 41-50.
86. Bearman, R.A. and C.A. Briggs, *The active use of crushers to control product requirements*. Minerals Engineering, 1998. 11(9): p. 849-859.
87. Swedish Standards Institute, S.S., *SS-EN 13242+A1:2007*, in *Ballast för obundna och hydrauliskt bundna material till väg- och anläggningsbyggande*. 2007.
88. Powell, M.S., et al., *Transforming the Effectiveness of a HPGR Circuit at Anglo Platinum Mogalakwena*, in *SAG Conference*. 2011: Vancouver.
89. Quist, J., *Cone Crusher Modelling and Simulation*, in *Department of Product and Production Development*. 2012, MSc thesis from Chalmers University of Technology: Gothenburg.
90. Evertsson, M., et al. *Control Systems for Improvement of Cone Crusher Yield and Operation*. in *Comminution '14*. 2014. Cape Town.
91. Robinson, G.K., *Predicting variation in planned mineral processing plants*. Minerals Engineering, 2003. 16(3): p. 179-186.
92. Guyot, O., et al., *VisioRock, an integrated vision technology for advanced control of comminution circuits*. Minerals Engineering, 2004. 17(11-12): p. 1227-1235.
93. Engblom, N., et al., *Effects of process parameters and hopper angle on segregation of cohesive ternary powder mixtures in a small scale cylindrical silo*. Advanced Powder Technology, 2012. 23(5): p. 566-579.
94. Banks, J., et al., *Discrete-event system simulation*. 5th ed. 2010, Upper Saddle River: Pearson Prentice Hall.

95. Marlin, T.E., *Process Control - Designing Processes and Control Systems for Dynamic Performance*. 2nd ed. 2000, New York: McGraw-Hill Chemical Engineering.
96. Sanchidrián, J.A., et al., *Size Distribution Function for Rock Fragments*. *International Journal of Rock Mechanics & Mining Science*, 2014. 71: p. 381-394.
97. Åström, K.J. and T. Hägglund, *PID controllers: Theory, Design and Tuning*. 2nd ed. 1995, Research Triangle Park: Instrument Society of America.
98. Papalambros, P.Y. and D.J. Wilde, *Principles of Optimal Design: Modeling and Computation*. 2nd ed. 2000, Cambridge: Cambridge University Press.
99. Kenne, J.P. and L.J. Nkenungoue, *Simultaneous control of production, preventive and corrective maintenance rates of failure-prone manufacturing system*. *Applied Numerical Mathematics*, 2008. 58: p. 180-194.
100. King, H., et al., *Development of a dynamic simulator for modelling complex flows in mineral processing circuits*, in *Comminution '12*. 2013: Cape Town.

MODELLING AND DYNAMIC SIMULATION OF GRADUAL
PERFORMANCE DETERIORATION OF A CRUSHING CIRCUIT –
INCLUDING TIME DEPENDENCE AND WEAR

Asbjörnsson, G., Hulthén, E., Evertsson, M., Modelling and Dynamic Simulation of Gradual Performance Deterioration of a Crushing Circuit – Including Time Dependence and Wear, Presented at the 3rd International Computational Modelling Symposium, 20-22 June 2011, Falmouth, UK, Published in Minerals Engineering (Journal), 2012, Volume 33, pp 13-19.



Modelling and dynamic simulation of gradual performance deterioration of a crushing circuit – Including time dependence and wear

Gauti Asbjörnsson*, Erik Hulthén, Magnus Evertsson

Chalmers Rock Processing Research, Chalmers University of Technology, SE41296 Gothenburg, Sweden

ARTICLE INFO

Article history:

Available online 4 March 2012

Keywords:

Dynamic simulation
Crushing
Modelling
SysCAD
Wear

ABSTRACT

The use of steady-state models in process simulation is a well-established method in many process industries. Designing a large crushing plant by relying on steady-state simulations alone will not generally provide the full picture of possible operational performance. The dynamics and variation between equipment and stochastic events can significantly reduce predicted plant performance. In order to dynamically simulate the crushing circuit, models for process equipment need to be further developed.

The purpose of this paper is to create a wear function for an existing Particle Size Distribution model (i.e., a *Swabrec-function*) with data obtained from a real crusher operating at gradually increasing closed side settings. This is done to create an accurate and updated model of the crusher in which the transient consequences of wear are captured. The *Swabrec-function* and correlation model were implemented into simulation software with simulated events; this simulation was validated with actual process readings. Improved simulations were then attained with the developed functions.

© 2012 Elsevier Ltd. All rights reserved.

1. Introduction

Modelling and simulation are important tools for many process industries. These tools are used to simulate a process to predict process behaviour under different conditions and constraints. Simulation results can be utilised for plant design and plant optimisation. For accurate simulations, it is essential that a model represents the reality of a process as closely as possible.

1.1. Comminution

Comminution is a process of progressively reducing particle size of rock material (Wills, 2006). The mining and aggregates industry utilise crushing plants to reduce the size of blasted rock from quarries into aggregate products or ores. A crushing plant is a configuration of different production units. These production units consist of crushers, screens, conveyors and bins. The number and configuration of units is dependent on the preferred performance for which that the plant and equipment were designed. The final product or products are produced by multiple reduction stages, the configuration of each depending on feed from the quarry and the purpose of the material. This can range from a single crusher with a pair of conveyors to several crushers in combination with a complex system of screens and conveyors.

In the aggregate industry, cone crushers are traditionally used in the last stages of the crushing plant to produce the final product. In cone crushers, the rock material is crushed a number of times by compressive crushing before it leaves the crushing chamber (Evertsson, 2000). This compressive crushing is made possible by an eccentrically rotating mantle within a concave. The smallest distance between the mantle and the concave during crushing operation is referred to as the *Closed Side Setting* (CSS) (Fig. 1), while the largest distance is the *Open Side Setting* (OSS). The difference between the CSS and the OSS varies between different mantle types and is often called the *Stroke*; it represents the eccentric throw of the mantle.

A cone crusher can be operated both at different CSS and at different eccentric speeds. CSS can be altered using a Crusher Control Unit (CCU) by changing, depending on the design of the crusher, either the vertical position of the mantle or the concave. Most crushers operate at a constant eccentric speed, but controlling the eccentric speed continuously during operation can have several benefits (Hulthén and Evertsson, 2010b).

1.2. Plant performance

Crushing plant performance is usually defined by the terms *Plant Capacity* and *Particle Size Distribution* (PSD), but additional terms such as cost can be used (Svedensten and Evertsson, 2005). In this paper, plant performance will refer to either capacity or PSD. Plant design and selected production units will have a

* Corresponding author. Tel.: +46 708 876 867.

E-mail address: gauti@chalmers.se (G. Asbjörnsson).

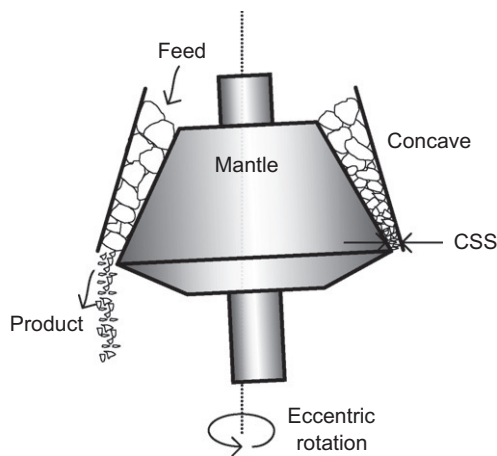

Fig. 1. Fundamental picture of a cone crusher.

dominating influence on plant performance, although plant performance is still far from predictable during an operation.

Overall plant performance is affected by several factors that can change during operation; these factors include machine settings and material properties. Changes in machine parameters can cause a change in plant performance (i.e., decreasing CSS will cause an immediate change in plant performance). Variations in feed material are caused by geological variation and depend primarily on the source of the material but how it affects the production is often unclear and hard to monitor continuously.

Plants are affected by gradually deteriorating performance over time in a form of wear. Wear results from abrasion between rock particles and the crushing chamber. The wear mechanics in compressive crushing is a complex phenomenon where the wear rate is affected by a number of factors, such as the properties of the incoming feed, motion of the particles, the PSD and more (Lindqvist and Evertsson, 2005). Due to wear the crusher properties will change, causing the CSS to gradually increase, i.e., the void ratio between the mantle and chamber will change. This will affect the shape of the PSD curve. During this study, the increase in CSS during a period of 4 h was observed in relation to change in the plant performance. Due to the relative shortness of the test compared to the overall lifetime of the mantle, changes in the mantle profile in this paper have been considered to be too small to contribute to any significant change in PSD.

1.3. Crushing plant simulation

Crushing plant simulations are used to predict plant performance by using flow sheets, as illustrated in Fig. 2. Most sim-

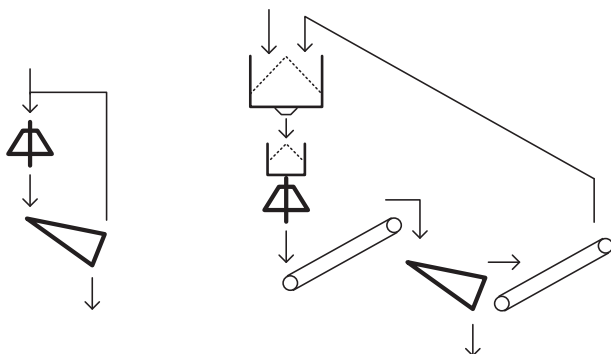

Fig. 2. Fundamental difference between steady-state and dynamic simulations – the dynamic simulation takes into consideration residence and lag time, while the steady-state simulation does not.

ulations perform steady-state simulations to evaluate plant design according to chosen setup (Svedensten and Evertsson, 2005; Whiten, 1974). Examples of available software packages that perform steady-state simulations are PlantDesigner (Sandvik), Aggflow (Bedrock Software), JKSimMet (JKMRC) and USIM PAC (Caspeo). In steady-state simulations, the plant is simulated until equilibrium is achieved.

In recent years, an interest in more dynamic simulations has been growing (Liu and Spencer, 2004; Napier-Munn and Lynch, 1992; Smith, 2005). Examples of available software that can perform dynamic simulations include SysCAD (Kenwalt), Aspen Dynamics (Aspentech) Simulink (Matlab) and Dymola (Dassault Systèmes). Even though plants experience a steady-state condition under certain circumstances, it is inaccurate to assume that the system is steady under all circumstances. Crushing is a continuous process; as a continuous system ($\dot{x}(t)$), equipment is subjected to variations (u_0) and changes over time (t).

$$\dot{x}(t) = f(x(t), u_0, t)$$

Given the initial condition,

$$x(t_0) = x_0$$

In a previous project at a crushing plant near Gothenburg, the change in plant performance was identified to be caused by wear in the crusher (Hulthén and Evertsson, 2010a). The studied circuit was quite stable and insensitive to stochastic changes in the upstream or downstream processes. The loss in production due to wear is illustrated in Fig. 3. The triangles represent the gradual decrease in the amount of finished product exiting the circuit, while the marked squares represent a loss of production due to adjustments of the mantle. Crusher throughput is not noticeably affected by short-time wear.

Both steady-state and dynamic simulations struggle to replicate this behaviour. Most dynamic simulations are based on steady-state models that do not consider wear to be significant factors in plant performance. Dynamic simulations are able to simulate events that can be used to represent disturbances caused by the calibration sequence. If the crusher is adjusted frequently, the time needed for calibrations can be up to 5% of the crusher's available time.

The purpose of the present study was to develop a wear function based on the parameters in the Swebrec-function (Ouchterlony, 2005) that can mimic the short-term wear for dynamic simulations. This would also create a correlation between machine parameters and the parameters included in the Swebrec-function. All simulations in this paper were performed with the simulation software SysCAD, which is capable of performing both steady-state and dynamic simulations.

2. Material and methods

To determine the correlation between time dependence and wear, a set of measurements were conducted at an aggregate plant in Uddevalla, 80 km north of Gothenburg. The crushing plant is owned and operated by NCC Roads. In its tertiary crushing stage, the plant produces high-quality aggregate products, ranging in size from 0–2 mm to 16–32 mm (see Fig. 4). The crusher is a Metso Nordberg HP4 cone crusher equipped with a medium chamber; the feed size to the tertiary crushing stage is 8–80 mm.

2.1. The test site

Due to the design of the crusher, the crushing chamber needed to run empty before the CSS could be adjusted to compensate for wear. The CSS was altered manually with an Original Equipment

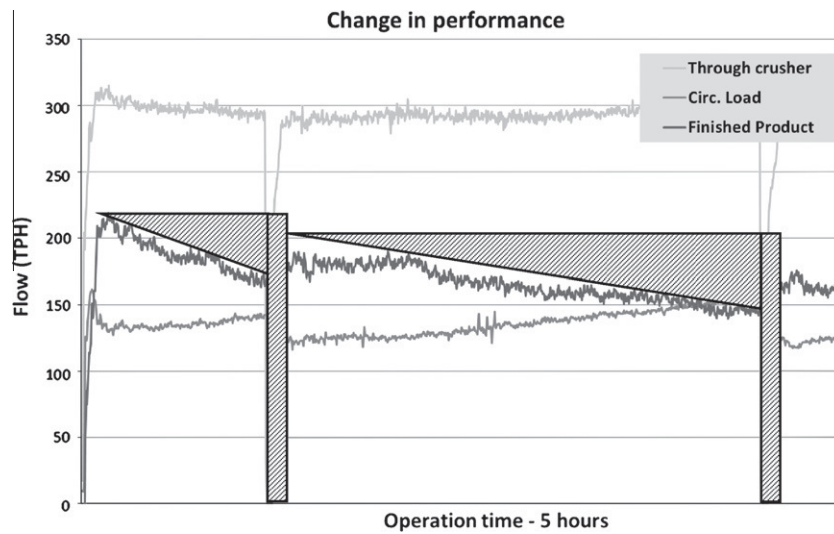

Fig. 3. Loss of production during operation marked with striped triangles; loss of production due to adjustment of the mantle marked with striped squares.

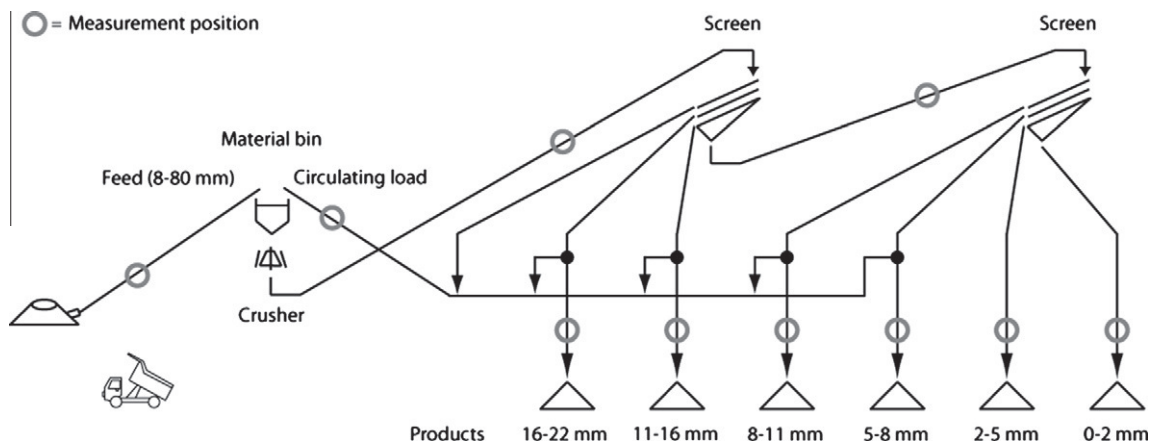

Fig. 4. Flow sheet over the tertiary phase of the test site. Belt scales are marked with a circle.

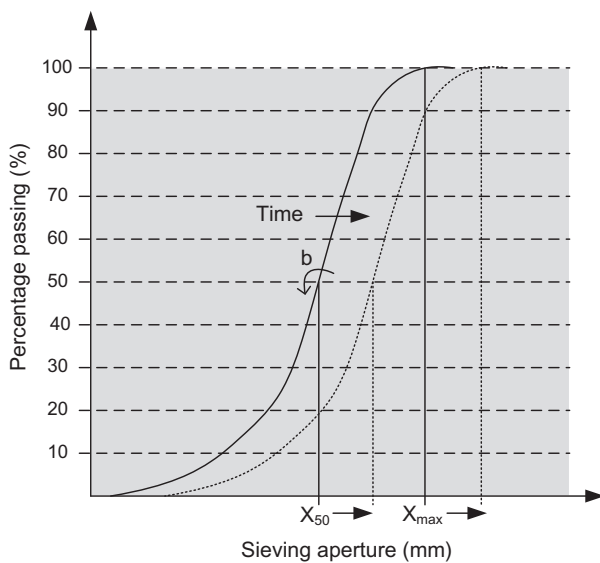

Fig. 5. Representation of parameters in the Swebrec function and how they are affected by time.

Manufacturer system by stopping the feed, unclamping the tread, rotating the upper shell and clamping the tread again. To compensate for wear and guarantee product quality, this manoeuvre was performed manually in 2- to 3-h intervals and took approximately 4–6 min. Although a frequency converter was installed on the crusher that allowed changes to be made to the eccentric speed in real time, the speed was kept constant during tests. All 10 conveyors in the tertiary phase were equipped with power meters that monitored and logged electrical power draw. From these data, the actual mass-flow could be calculated (Hulthén and Evertsson, 2006).

2.2. Experiment procedures

In order to measure the gradual changes in the PSD in comparison to changes in the crusher, the CSS was measured. Lead cubes were lowered down into idling crushing chambers to be deformed to the actual CSS. This procedure was repeated a number of times with certain time intervals. During the tests and crushing operation, plant performance, production output and power drawn by the crusher were monitored and logged. From the plant data, the change in the plant output could be mapped.

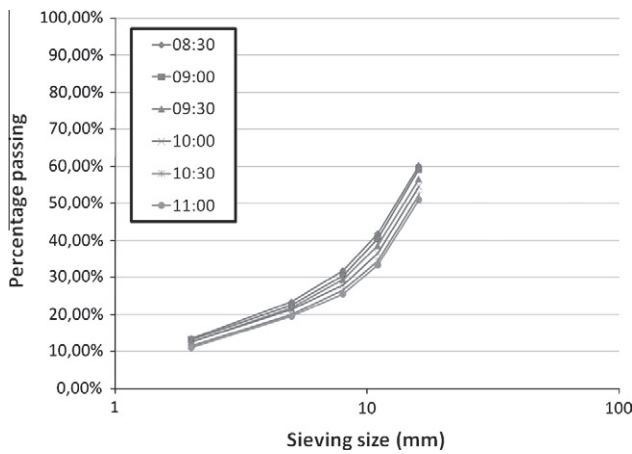

Fig. 6. Change in the calculated PSD from belt scales over time.

3. Mathematical modelling

For a better understanding of the process dynamics, the product should be considered to be a time-dependent vector ($P(t)$). The values will therefore change over time due to various factors.

$$\frac{\partial P}{\partial t} = P(t) = \begin{bmatrix} P_1(t) \\ P_2(t) \\ \vdots \\ P_{n-1}(t) \\ P_n(t) \end{bmatrix}$$

To improve the dynamic simulation, the plant's gradually decreasing performance needs to be modelled with the existing

crusher model. In previous work, the Swebrec-function has been studied to approximate the PSD from the crusher with dynamic simulations (Asbjörnsson, 2011). The Swebrec function, depicted below, was developed to describe the PSD of blasted rock (Ouchterlony, 2005) but can be applied to crushed rock (Svedensten and Evertsson, 2005) with certain accuracy. The Swebrec function is depicted as:

$$P(x) = 1 - \left(\frac{\ln\left(\frac{X_{max}}{X}\right)}{\ln\left(\frac{X_{max}}{X_{50}}\right)} \right)^b$$

where X_{50} represents the aperture point for 50% of the cumulative weight, X_{max} represents the largest particle in the PSD, b is the slope of the curve and X is the defined PSD interval (see Fig. 5). During this study, the simplest form of the Swebrec function was used. One of the drawbacks with this form is the inability to predict fines accurately. To represent the fine tail in this process, the smallest fraction has been set to 2 mm, which is the finest product screened out by the plant.

4. Results

From the process reading, the PSD could be estimated while parameters could be derived from the data collected. Each belt scale can be considered to hold a certain size interval. From this assumption, an approximation of the PSD curve can be fitted with the Swebrec function. The PSD curve was changed over time due to abrasion between the crushing chamber and the rock material. As more material goes through the crusher, wear gradually moves the PSD curve in the horizontal direction, as can be observed in Fig. 6. To compensate for this development, the crusher is calibrated, which restores it to a narrower CSS.

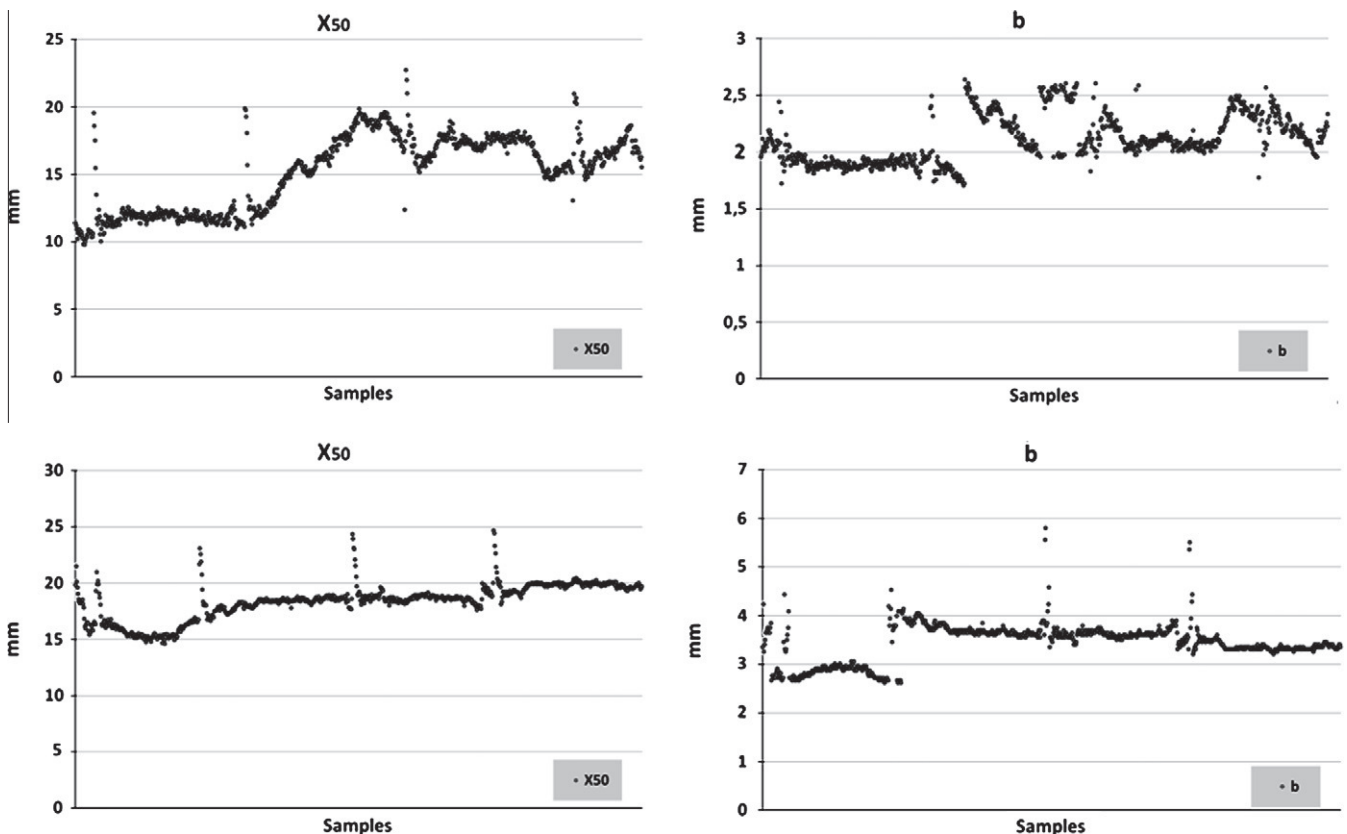

Fig. 7. Calculating X_{50} (left figures) and b (right figures) from the process readings at two of the test periods.

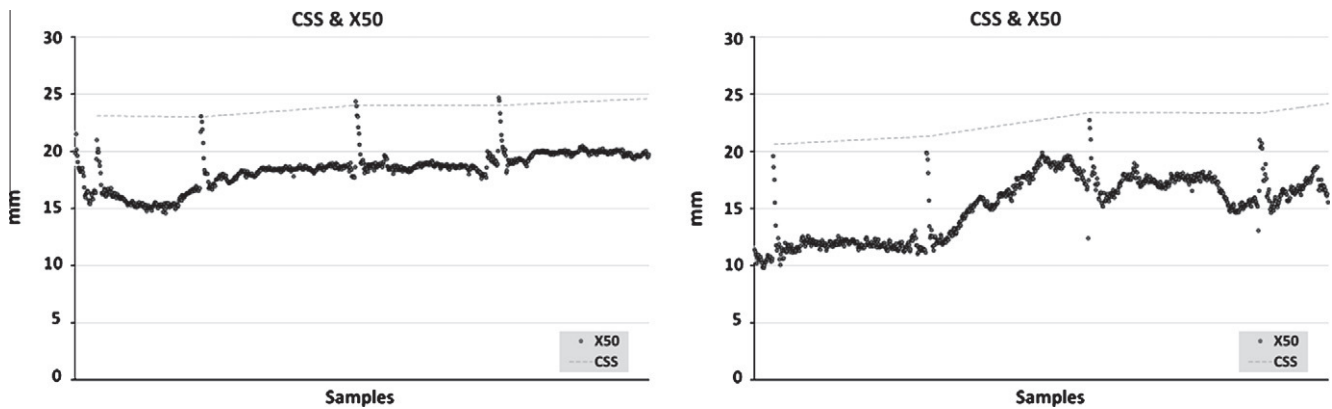

Fig. 8. The trend of CSS (dotted grey line – interpolated between tests) and X_{50} (black dots – process readings) as a function of material flow through the crusher at two of the test periods (approximately 4 h). The results are close to parallel. Spikes in the X_{50} curve indicate an interruption in the process due to calibrations or mechanical failure.

The Swebrec-function was fitted to the PSD of the belt scales by interpolating X_{50} from the process readings. X_{max} was estimated by adding the calculated change in X_{50} to the defined OCC. Finally, b was iterated out by comparing the Root Mean Square (RMS) error of the results from every b and the actual PSD for that moment. RMS error was calculated as:

$$RMS = \sqrt{\frac{\sum (PSD_{calculated,i} - PSD_{BeltScales,i})^2}{n}}$$

By calculating the change in the three parameters, X_{50} , X_{max} and b , the wear function could be created. The data from the calculation are presented in Fig. 7. Fig. 7 shows how X_{50} gradually increases during the test period, while b is inconsistent with a small localised decrease which varies within a certain interval. Spikes in the diagrams are due to disturbances in the process from measuring the CSS.

Fig. 8 presents the results from two of the calibrations combined with the calculation of X_{50} during these test periods. The correlation between the measured CSS and the calculation of X_{50} was between 0.6 and 0.8, with the average of all of the test periods being 0.71. Because the measured CSS and calculated change is close to parallel, it can be presumed that the wear was concentrated near the point of the CSS. Between some calibrations, the CSS seems to decrease. This could be caused by many factors, such as uneven wear on the mantle or inaccurate measurements. To minimise the risk of uneven measurements, the same procedure was performed at every test.

By analysing the change in the predefined parameters, the wear function was generated. Fig. 9 shows the collected data, which are presented as a change at defined intervals, from the calibration. This gives a simplified indication of the wear trend that occurred during the tests.

Equations were formulated for the Swebrec parameters to approximate the product change over time. This was done to create a wear function based on the amount of crushed material between mantle adjustments.

$$X_{50} = a_1 * CSS_0 + a_2 \int_0^t m dt$$

The parameter a_1 represents the ratio between the initial CSS and X_{50} after a mantle adjustment while a_2 represents the wear rate depending on the amount of crushed material per hour. X_{max} was considered to be directly proportional to the OSS, as the size fraction will be approximately as large as the largest settings. The OSS increases the same amount as the CSS during drift, with the average rate shown in Fig. 9. The change in CSS will follow the same

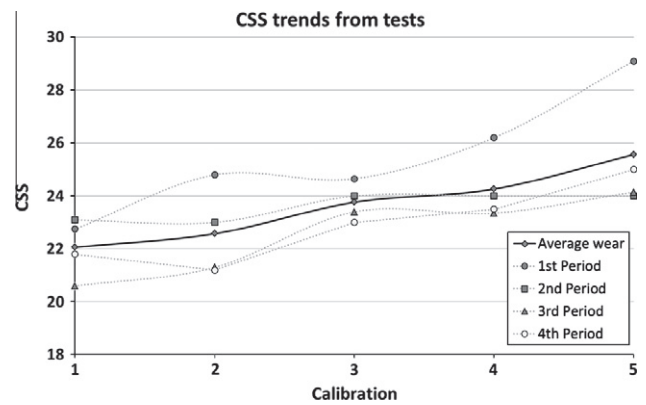

Fig. 9. Wear trend (black line) generated from the calibration results.

rate as the change in X_{50} during operation. Parameter b was later considered to be constant during the drift as the b parameter in the data was inconsistent and only varied within a small interval.

5. Application of wear function

To validate the developed wear function, the plant was modelled with the SysCAD simulation software package. Both steady-state and dynamic simulations were performed and compared to real-time data. The Swebrec function was modified to include the wear function for the defined parameters, and a simplified version of the plant controllers was created. All simulations were initiated with the same PSD and CSS. The steady-state simulation was run until equilibrium was achieved; dynamic simulations were run for the same duration as the real crushing operation. All disturbances during testing were logged and entered as events in the simulation. To not affect the full-scale test, the starting CSS was estimated for the simulation by calculating the X_{50} parameter. In Fig. 10, the flow sheet of the test plant can be viewed.

The results from the simulation and the test can be viewed in Fig. 11. No variation was added to the simulation. Although there are many similarities between the simulated process and the actual process, there are some distinct differences. By analysing the actual process readings, it became evident that one or more belt scales needed to be calibrated. This is because, according to the process readings, more material enters the system than is being produced. As can be observed in the simulated results, the lines *From secondary* and *Product* should be in line with each other, not parallel. Also, the amount of *Product* and *Circulating Load*

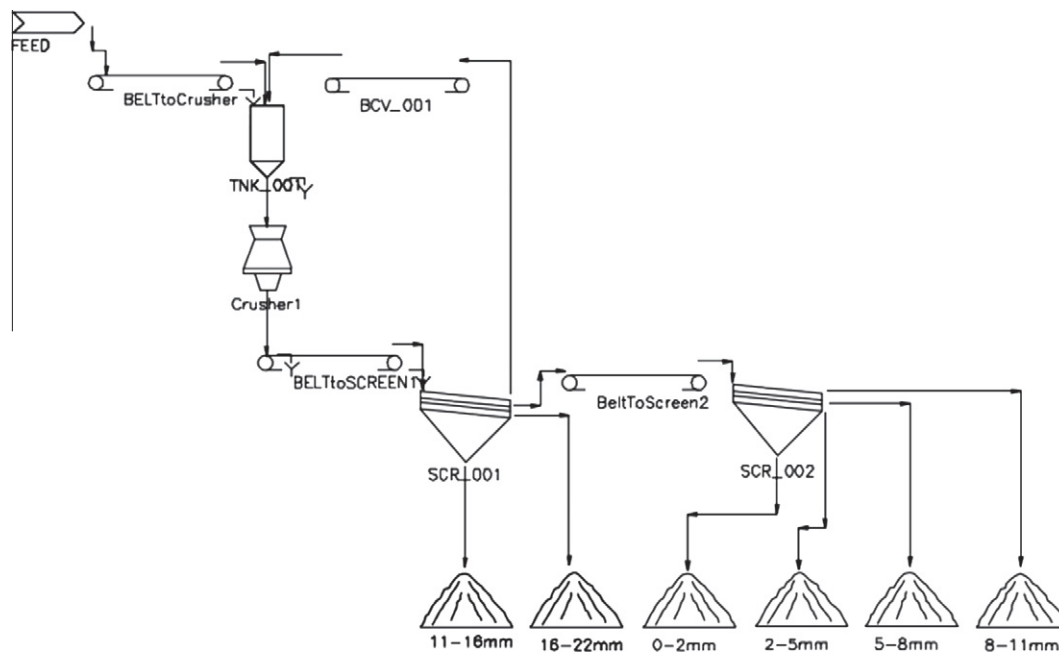

Fig. 10. Flow sheet of the modelled plant in SysCAD.

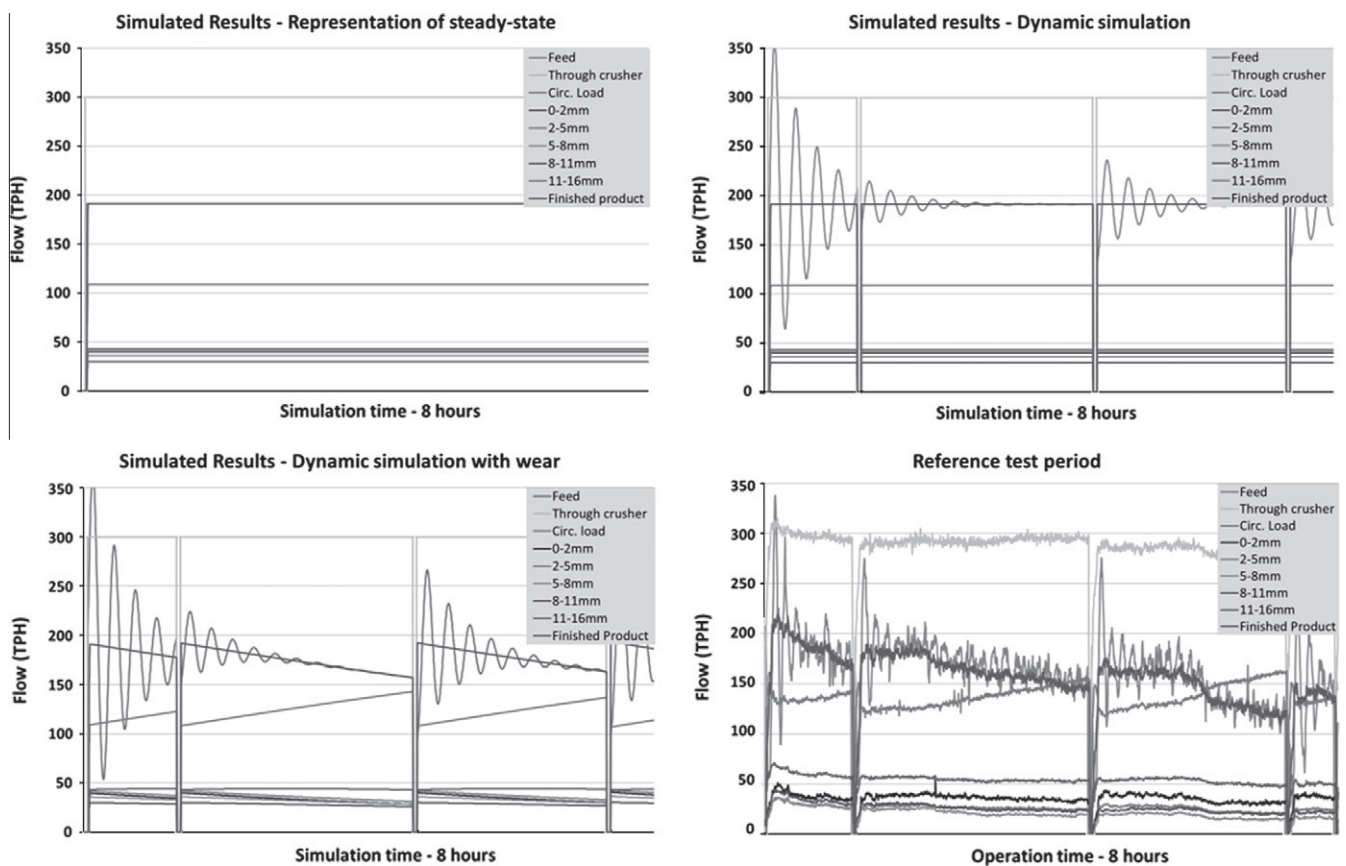

Fig. 11. Representation of steady-state simulation results (upper-left), dynamically simulated flow with calibration events (upper-right), dynamic simulation with events and wear function implemented (lower-left) and actual reference flow after modification to compensate for un-calibrated belt scales (lower-right).

should equal the *Material through crusher*, which is, in other words the crusher capacity. By studying the process readings while the

plant was idling (i.e., at startups or during calibration), the error due to un-calibrated belt scales could be minimised.

Table 1

Comparing the error of the product produced from dynamic and steady-state simulations to the actual flow.

Process	Average performance (TPH)	Error (%)
Actual	161.0	–
Dynamic simulation with wear function	172.6	7.2
Dynamic simulations without wear function	185.2	15.0
Steady-state simulation	189.2	17.5

By comparing the dynamic simulation, the steady-state simulation and the process data, the error could be calculated. By analysing the amount of product produced during the production and the simulated time, the simulation error could be calculated, as illustrated in Table 1.

As can be seen the dynamic simulation Fig. 11- Finished Product and Table 1), the wear function shows significant improvement in representing the actual process when compared to the steady-state simulation, showing only a 7.2% deviation from the actual process. The error for the dynamic simulation without the wear function is not much greater than the steady-state simulation with interruptions. The dynamic simulation with implemented wear function resulted in a 10.3% improvement over the steady-state simulation. Due to the manual nature of the procedure, the CSS will never return to the initial CSS value. Thus, additional improvement could be achieved by running the simulation at the same CSS after each mantle adjustment.

6. Conclusions and future work

In this paper, a wear function for dynamic plant simulations was presented that is capable of improving dynamic simulations. Full-scale tests were performed both to collect data and to validate the wear function. During validations, it has been shown that dynamic simulations can be improved to better represent the actual process. These types of simulations, which work to improve dynamic simulation in plant design, can serve to increase plant insensitivity to variations, such as wear and malfunctions.

Although these tests gave a clear indication that there is a correlation between a change in the PSD and changes in the CSS, it is not possible to say a definite correlation exists between the PSD and the CSS from these data alone. As stated in the introduction, several other factors, such as degree of reduction and material properties, can contribute to wear. These factors were close to constant during the testing as the material came from the same source, and it was crushed and screened in the secondary stage. The purpose of this paper is not to create a general wear function

for all crushers or processes but rather to identify a way to better represent the production process with dynamic simulation.

When comparing the dynamic simulation with the actual process, it was possible to identify belt scales that needed to be calibrated. By running dynamic simulations in parallel with the production it was possible to identify malfunctions before they could cause severe problems, such as failures on the conveyors.

The next step is to study data from various periods in a mantle's lifecycle to identify how long-term wear affects the PSD and crusher capacity for the purpose of dynamic plant simulation.

Acknowledgements

This work has been performed within the Sustainable Production Initiative and the Production Area of Advance at Chalmers; this support is gratefully acknowledged.

The authors wish to thank the Hesselman Foundation for Scientific Research and the Swedish national research program MinBaS (Minerals, Ballast and dimensional Stone) for its financial support.

NCC Roads and their personnel in Glimmingen, Uddevalla, are gratefully acknowledged for all of their support and efforts to make this work possible.

References

- Asbjörnsson, G., 2011. Modelling och simulering av dynamiskt beteende i krossanläggningar. MinBaS.
- Evertsson, C.M., 2000. Cone Crusher Performance, PhD Thesis. Chalmers University of Technology, Gothenburg, Sweden.
- Hulthén, E., Evertsson, C.M., 2006. A cost effective conveyor belt scale. In: 11th European Symposium on Comminution. The Hungarian Chemical Society (MKE), Budapest, Hungary.
- Hulthén, E., Evertsson, C.M., 2010a. Real-Time Optimization of Cone Crushers, PhD Thesis. Chalmers University of Technology, Gothenburg, Sweden.
- Hulthén, E., Evertsson, C.M., 2010b. Two variable real-time algorithm for cone crusher control. In: Proceedings of XXV International Mineral Processing Congress. Brisbane, Australia.
- Lindqvist, M., Evertsson, C.M., 2005. Wear in Cone Crusher Chambers, PhD Thesis. Chalmers University of Technology, Gothenburg, Sweden.
- Liu, Y., Spencer, S., 2004. Dynamic simulation of grinding circuits. Minerals Engineering 17 (11–12), 1189–1198.
- Napier-Munn, T.J., Lynch, A.J., 1992. The modelling and computer simulation of mineral treatment processes – current status and future trends. Minerals Engineering 5 (2), 143–167.
- Ouchterlony, F., 2005. The Swedbrec function: linking fragmentation by blasting and churning. Mining Technology 114, A29–A44.
- Smith, H., 2005. Process simulation and modelling. In: Mike, D.A., Wills, B.A. (Eds.), Developments in Mineral Processing. Elsevier, London, pp. 109–121.
- Svedensten, P., Evertsson, C.M., 2005. Crushing plant optimisation by means of a genetic evolutionary algorithm. Minerals Engineering 18, 473–479.
- Whiten, W.J., 1974. A matrix theory of comminution machines. Chemical Engineering Science 29 (2), 589–599.
- Wills, B.A., 2006. Mineral Processing Technology: An Introduction to the Practical Aspects of Ore Treatment and Mineral Recovery. Elsevier, London.

MODELLING DYNAMIC BEHAVIOUR OF STORAGE BINS FOR MATERIAL HANDLING IN DYNAMIC SIMULATIONS

Asbjörnsson, G., Hulthén, E. and Evertsson, C. M., Modelling Dynamic Behaviour of Storage Bins for Material Handling in Dynamic Simulations, Presented at the XXVI International Mineral Processing Congress, 24-28 September 2012, New Delhi, India, Published in the conference proceedings.

MODELLING DYNAMIC BEHAVIOUR OF STORAGE BINS FOR MATERIAL HANDLING IN DYNAMIC SIMULATIONS

Gauti Asbjörnsson^{1,*}, Erik Hulthén² and Magnus C Evertsson³

ABSTRACT

Material handling is an essential part of the aggregate and mining industries. Mixing and blending of granular material can affect the grading and particle size distribution of the material leaving the system. Segregation and variability can cause problems in the downstream process while insufficient capacity will disturb upstream processes.

Process plants utilize surge bins for handling recycle streams of material and act as a buffer for the process. The flow through the surge bin is usually controlled by a simple PID controller or PID controller in combinations with a plant-wide controller. Even though the surge bins play an important role of smoothing out the plant and creating a steady operating condition they are seldom included in plant simulations. This can lead to a number of problems in the form of decreased plant capacity, plant lockdown, and even operation units malfunctioning.

The main objective of this study is to investigate the dynamic behavior in surge bins and develop a model more suitable for representing this behavior, which can occur during operation, for dynamic simulations. The proposed model adopts vertical layers which allow for flows between segments depending on the level of neighboring segments. This enables both the representing of segregation within the system and gives an indication on the effects from different inlet- and outlet placements. The proposed model was developed in MATLAB/Simulink and validated against an actual bin with the total capacity of 660 m³ in platinum ore application. With the new bin model significantly higher fidelity and more accurate dynamic, simulation results were achieved.

Keywords: Simulation, Modeling, Segregation, Material handling, MATLAB/Simulink

INTRODUCTION

Crushing plant simulations are currently used to predict plant performance. By being able to predict the plant performance, the plant design or configuration can be optimized to maximize production and improve profitability. Usually these simulations are done by state-state simulations which do not take into perspective factors such as time delay, residence time or plant controls. Plants operate at various conditions where the state is only determined by the momentary condition of each individual operation unit and interactions within the entire system

Surge bins play an important role in every process for mixing the material, handling recycled material or acts as a buffer, for the process to keep it at a steady conditions. Due to the fact that the surge bins are not included in the traditional plant simulations, they are sometimes overlooked, and the necessary capacity and characteristics are underestimated. Bigger is not necessary better in all cases as the economical constraints often drive the developers to keep the designed capacity just above the necessary requirements. Variations and transients events will cause a momentary change in the system, and if the operation units and the control system are not designed for the handling the changes it can result in restricted plant performance and product quality.

Simulations software's aimed for dynamic simulations have the capability to simulate the dynamic behavior that occur in a process plant to some extent such as calculating cumulative volume in the surge bins and estimating the delay-time

1. Chalmers University of Technology, SE-41296 Gothenburg, Sweden. gauti@chalmers.se

2. Chalmers University of Technology, SE-41296 Gothenburg, Sweden. erik.hulthen@chalmers.se

3. Chalmers University of Technology, SE-41296 Gothenburg, Sweden. magnus.evertsson@chalmers.se

of conveyors and other operation units. In the case of the bins models, the models used for plants simulations are only a rough estimation of reality and are derived from first-order system which is solved by a differential equation (ODE). This means that the particles within the system are perfectly mixed, and the material has an even surface bed over the entire bin.

The main objective of this study is to investigate the dynamic behavior in surge bins and develop a model more suitable for representing this behavior, which can occur during operation, for dynamic simulations. The proposed model adopts vertical layers which allow for flows between segments depending on the level of neighboring segments. Enabling both the representing of segregation within the system and identifying the effects from different inlet- and outlet placements. The proposed model was developed in MATLAB/Simulink and validated against an actual bin with the total capacity of 660 m³ in a platinum ore application.

EARLIER WORK

In the authors earlier work the focused was on representing the effects from wear in an aggregate plant in commercial dynamic plant simulation software. An improved fidelity in the simulation was achieved compared to regular steady, state and unmodified dynamic simulation (Asbjörnsson *et al*, 2012). In the following work, the authors used MATLAB/Simulink to develop a simulator capable of evaluating plant performance. The developed bin model in this paper was used during that study. The simulation revealed that the plant reached performance saturation before it was able reach the set target production. By evaluating and simulating different configuration, the simulation showed a potential production increase of 13.3%. Validation trails with selected suggested modification showed 4.9% production increase while the plant was in full operation (Asbjörnsson *et al*, 2012).

MODELING BACKGROUND

In a crushing circuits, bulk material handling is essential. Buffers of material are strategically placed within the circuit to guarantee the sufficient material is always available for the production downstream. Buffers can be considered as stockpiles or surge bins. In process simulations, these surge bins are usually consider being mixed or non-mixed integrated tanks where the accumulation granular material is either modeled as perfectly mixed or considered to follow the Principle of First-In-First-Out (FIFO). Both systems follow the principle of a first order differential system which is essential when calculating the accumulation of mass.

As discussed described in the introduction, this is not sufficient for the fidelity of the simulations. Flow of granular particles can be rather complex and disturb the process throughput and as well as the quality of the product which is being produced. Plants sometime struggle reaching their set throughput during the start-up phase and can require modifications to the layout and machinery to reach their set target. Often this could be avoided with deeper analyzes of the process prior to actual construction and initiation of the plant with tools such as Discrete Element Method (DEM) and Dynamic simulations. During a plant survey, at a plant struggle to reach their set production target the authors noticed that the problem to the instability of the plant partly originated in the surge bin, due to the design of the surge bin within the process and control of the plant, see Figure 1.

This bin measured 16.5x5.5x7.5 m, which gives the overall capacity 660 m³. By estimating the amount of dead volume, (volume not possible to utilize during operation) this could be reduced to approximately 600 m³. The bin is supposed to assure a steady supply of material to the three CH880 cone crushers, see Figure 1 and Figure 2 **Error! Reference source not found.** The material fed to the crushers can be considered to be coarse and fine. The coarser fraction is the grizzly oversize from the primary crusher and is approximately 80-300 mm while the fine fraction is the re-circulating load and should be approximately 45-80 mm.

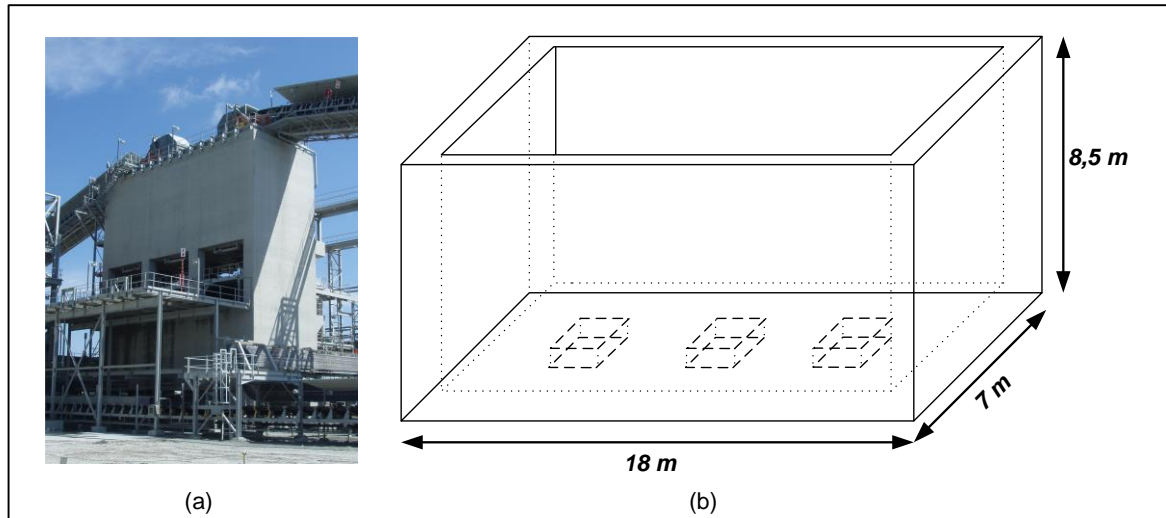

Figure 1. The actual bin (a) with a schematic picture of the bin (b) with the opening for the feeders below.

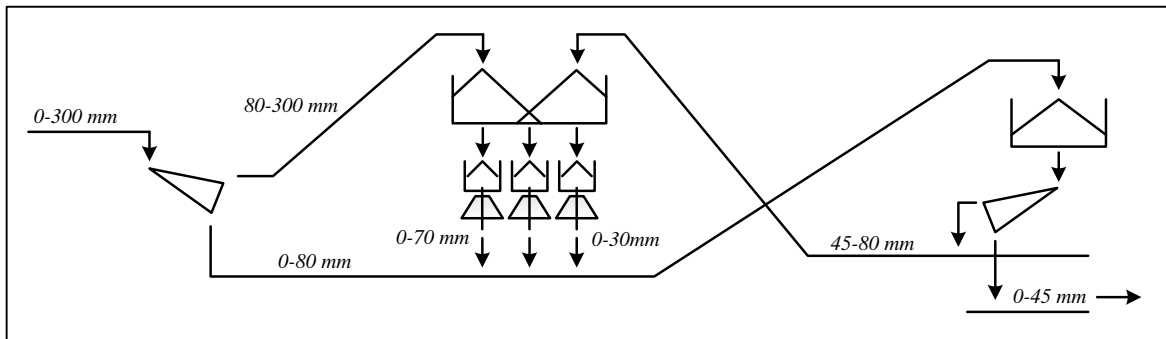

Figure 2. Part of the plant flowsheet illustrating the layout, together with the estimated interval of the particle size distribution across the plant.

Due to the distance between the incoming feeds, and the particle size distribution the material will not mix sufficiently and result in a vertical segregation within the bin. The consequence of this is that crusher 1 (coarse crusher) only gets coarse material, crusher 3 (fine crusher) only gets fine material, and crusher 2 (intermediate crusher) gets a combination of fine and coarse material depending on flow and the level in the bin. This increases the risk of fatigue problem in crusher 2 as it will experience increased pressure fluctuations within the crushing chamber due to the fact that it will have coarse material one side of the cone while the finer material is on the other side.

Three level meters are placed above the bin to monitor the height of the material within the bin, these are placed near each crusher. Studying the data from the level meters and observing the bulk surface it is clear that the surface are being far from even and that there is a pile-up of material underneath the conveyors with a certain angle of repose (see Figure 3). On the other hand, of no or little new material was fed to the bin while the crusher were operating that angle would become negative.

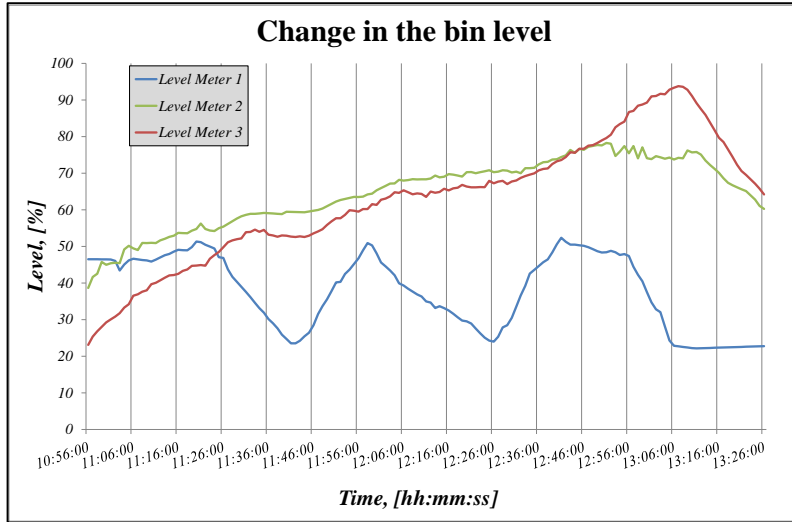

Figure 3. Level readings from the plant SCADA system.

In order to estimate the live capacity of the crusher, a bin residence time test was performed. A total of 20 tracers were dropped into the flow coming into the bin while the level was at 51% above the fine crusher (crusher 3) and the time it took for material to travel through the bin and feeder pan was measured. The tracers used were a batch of 10 at two different size fractions, approximately 45mm and 150mm. The smaller fraction was chosen according to size fraction in the material flow while the other was chosen to be relatively larger than the surrounding particles. The results from the residence time test can be observed in Figure 4 where the average time for the smaller tracer to travel through was 290 seconds or 4:50 minutes while the average residence time for the larger particles was 314 seconds or 5:14 minutes.

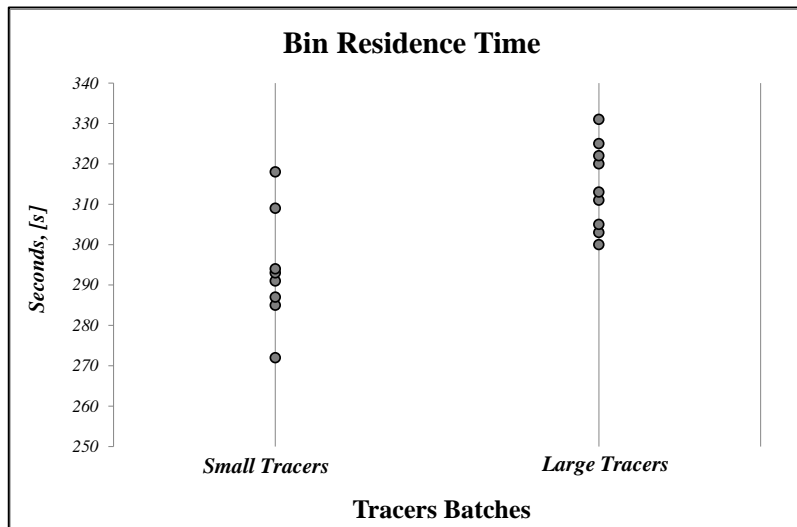

Figure 4. Results from residence time test performed on the bin.

Calculating out the live capacity from the residence time test with the approximate time it took for the material to travel over the feeder pan withdrawn, revealed that the live capacity of the crusher bin was only 37 m³, taken into account that the level at the start of the test was 51%. This is too far from the measured capacity of 600 m³ for the 3 sections. This deviation can be explained by a funnel flow in the material. According to Schulze (Schulze, 2008) and Engblom (Engblom *et al*, 2011) is the risk funnel flow highly dependent on the angle of the bottom surface of the bin or silo. Where a flat-bottom bin increases the risk for creating a funnel in the material compared to a bin with a bottom with a steep angle.

BIN MODELING

The developed model is divided into several segments to be able to represent the actual process closer and to approximate the natural behavior which occurs within the bin. Instead of approximating the system as an either layered or un-layered non-mixing section, vertical section were adapted where the section(s) corresponding to the outflow section act semi-independent from the performance of the other outflow sections, See Figure 5.

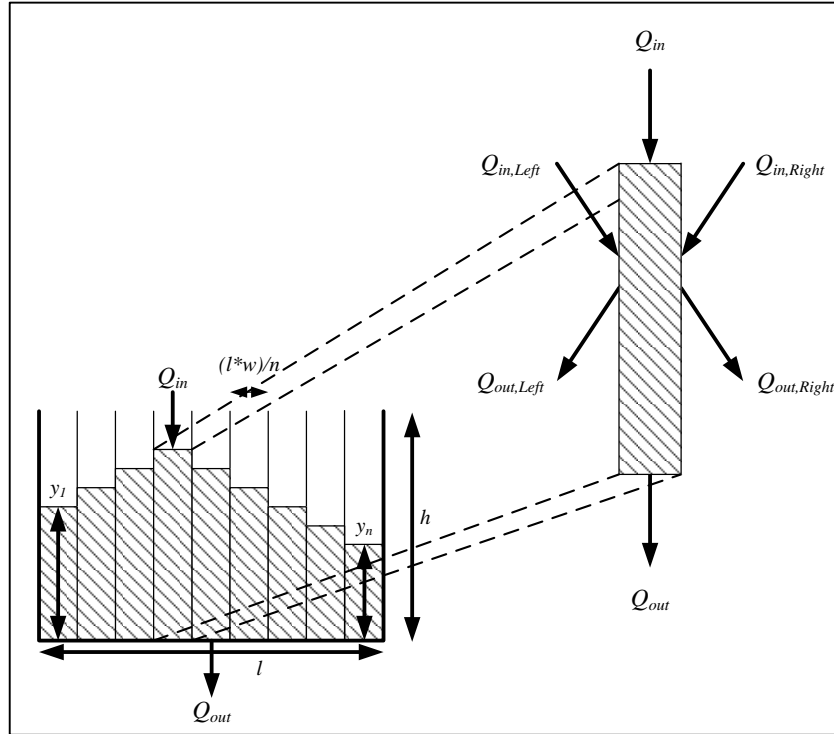

Figure 5. Principle idea with the developed bin model.

The model is defined by the number of layers (y_1, y_2, \dots, y_n) within the system and the feed (Q_{in}) and product (Q_{out}) placement are positioned in an appropriate section according to the reference bin. The basic measurements for the bin are entered, length (l), width (w) and height (h) in order to estimate the available space within the system. Looking closer into a single segment the flow within that particular segment, flow in (Q_{in} , $Q_{in,Right}$ and $Q_{in,Left}$) and flow out (Q_{out} , $Q_{out,Right}$ and $Q_{out,Left}$) can be described by the following equation (Eq. 1), given the initial condition at the time $t = t_0$.

$$y_i(t) = \int_{t_0}^t (Q_{in}(t) + Q_{in,Left}(t) + Q_{in,Right}(t) - Q_{out}(t) - Q_{out,Left}(t) - Q_{out,Right}(t)) dt + y_i(t_0) \quad (1)$$

During operation as well as with simulations, the material focus is always on the total mass of the transported material. This is easy to measure during operation with belt scales, but this has to be changed into volumetric flow to be able to calculate the amount of space that specific mass occupies. Volumetric flow (Q) rate is defined as (Eq. 2).

$$Q = \frac{\Delta V}{\Delta t} = \frac{\Delta m}{\Delta t \cdot \rho_{bulk}} \quad (2)$$

Where ΔV and Δm equals the change in volume respective mass, Δt is the time interval for the mass and ρ_{bulk} is the density of the bulk material which will be described in detail later.

Flow model

How the material flow within the system is fundamental for the fidelity of the model. The model has been developed so it takes into account the number of segments within the system (n), feed and product placements (F_i resp. P_i), geometry of the bin (l , w and h) and the angle of repose (α). According to Metcalf (Metcalf, 1966) the angle of repose varies between 30 – 40 degrees for stockpiles depending on the material and the internal friction of the material. But due to the flow of material from beneath the material bed and the wall interaction this will be somewhat lower within the bin.

In Figure 6, few different possible flow scenarios are illustrated. The flow will depend on the level in the neighbouring segments. If the level is below the critical overflow level, the material will spill over to the neighbouring segment or segments depending on the momentary levels.

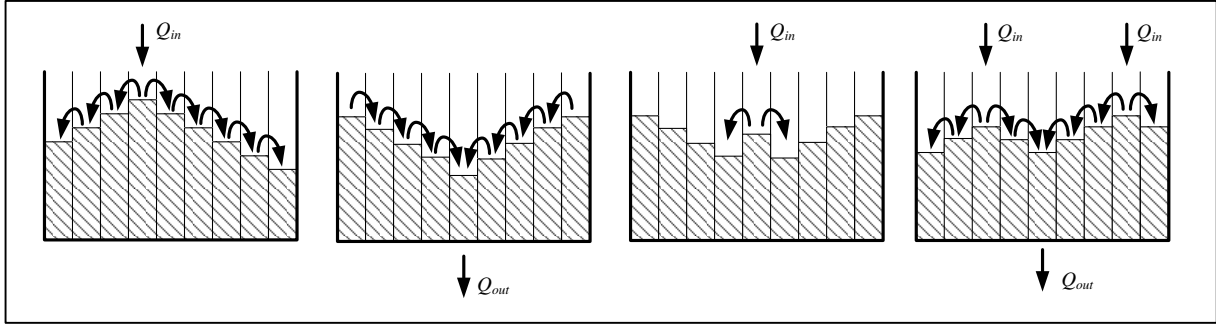

Figure 6. Representing different scenarios that can occur during loading (Q_{in}) and unloading (Q_{out}) of a bin.

Bulk density Model

The packing of the material bed is highly dependent on the particle size distribution. A narrow size fraction will result in a large amount of voids in the material bed between particles and therefore, decrease the volume density. For a wider distribution, the smaller particle is able to move between the larger particles and fill in those voids creating more dense material bed. To determine the volume of the accumulated mass it is therefore, necessary to know the bulk density. Evertsson (Evertsson, 2000) proposed a method for approximating bulk density with respect to particle size distribution and the actual solid density (Eq. 3).

$$\rho_{\kappa} = D_1\sigma_{\kappa}^3 + D_2\sigma_{\kappa}^2 + \rho_{\kappa,mono} \quad (3)$$

A dimensionless measure of the actual density is defined by the parameter ρ_{κ} , where the lowest possible normalized bulk density for a mono fraction is $\rho_{\kappa,mono}$. The spread in the particle size distribution is described by parameter σ . Parameters D_1 and D_2 are empirically fitted constants. This is calculated using standardized statistical analyses for calculating the standard deviation of a sample where the observations x_1, x_2, \dots, x_n occur with the frequencies f_1, f_2, \dots, f_n the variance σ^2 with N number of observations and the standard deviation is defined by Eq. 4-6 :

$$\sigma^2 = \frac{1}{N-1} \sum_{i=0}^n f_i (x_i - \bar{x})^2 \quad (4)$$

$$\bar{x} = \frac{1}{N} \sum_{i=0}^n f_i x_i \quad (5)$$

$$N = \sum_{i=0}^n f_i \quad (6)$$

Experiments have been performed on different particle size distributions, and Eq. 3 fitted to the data to represent altered bulk density from a mono fraction to an evenly spread size distribution, see Evertsson (Evertsson, 2000). A maximal and minimal theoretical normalized density was also calculated in order to estimate the interval in which the bulk density is within, the parameters $\rho_{\kappa,mono}$ and $\rho_{\kappa,max}$ are therefore, 0.55 resp. 0.71. From the data fitting, the following parameters were attained.

$$D_1 = -0.062277 \qquad D_2 = 0.24758$$

Simulink Model

In **Figure 7**, a part of the developed model is illustrated, the model was developed in MATLAB/Simulink. The models input modules includes mass flow(s) (Q_{in} and Q_{out}) and particle size distribution(s) defined by the top size ($F100$) and the 50 percent cumulative passing size ($F50$) of the incoming feed as well as all the important system parameters. These factors are imported into the calculations and will produce outputs which consist out of particle size distribution(s) and levels (y_i) in sections where level meters have been positioned. Mass flows from the bin (Q_{out}) are not an output from the calculation as it is usually controlled by a feeder that supplies the crushers with material.

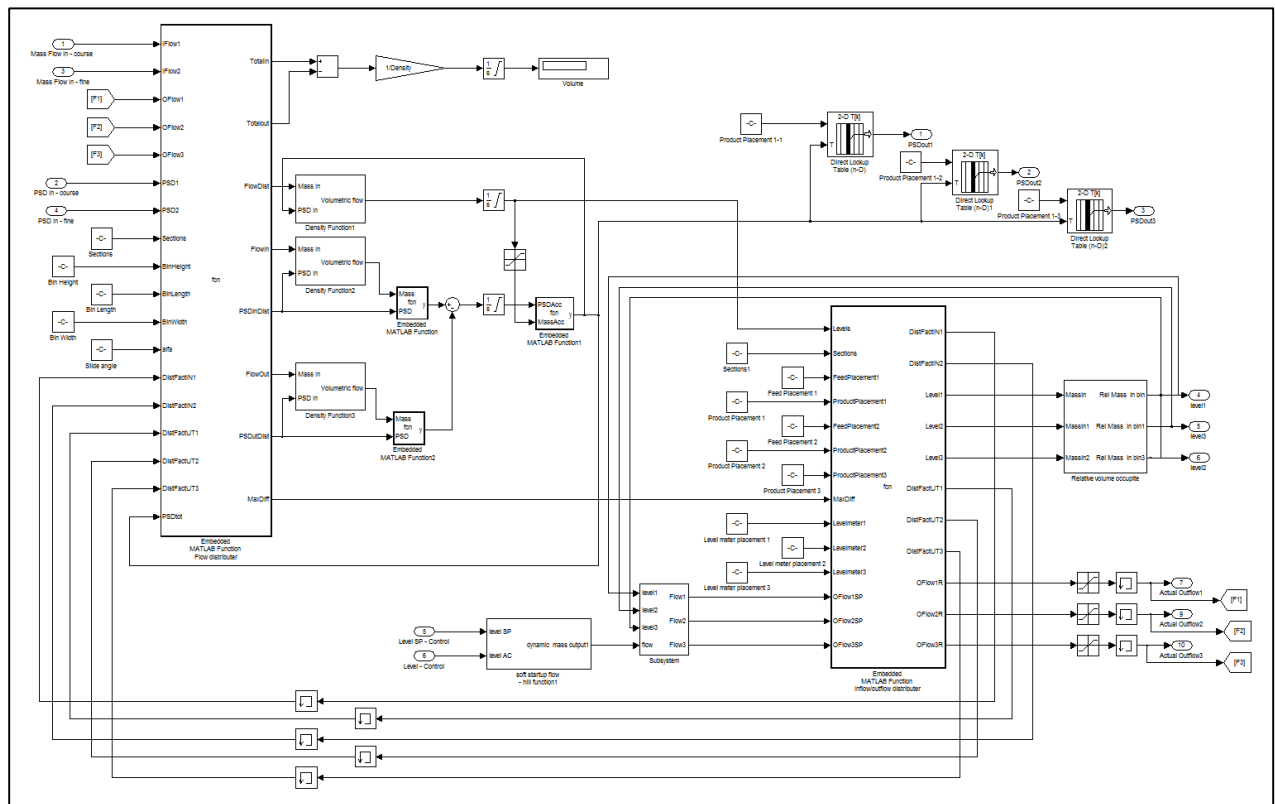

Figure 7. Overview of a part of the model in MATLAB/Simulink.

SIMULATIONS

In order to illustrate the functionality of the developed model two different scenarios have been simulated. The first one represents the level increase for all segments in a stockpile and the second one is an implementation of the bin in dynamic simulations.

Stockpile simulation

To demonstrate the model simulations were setup to represent the increase in level in each segment for a stockpile. At the start of the simulation, the level increases relatively rapidly until it reaches the critical level and starts to flow over to the neighboring segments where the feed rate becomes distributed over more segments, see Figure 8a. Every time a new segment is commenced the rate that the level is increasing will decrease because the feed rate into individual segment is decreased as illustrated in Figure 8b.

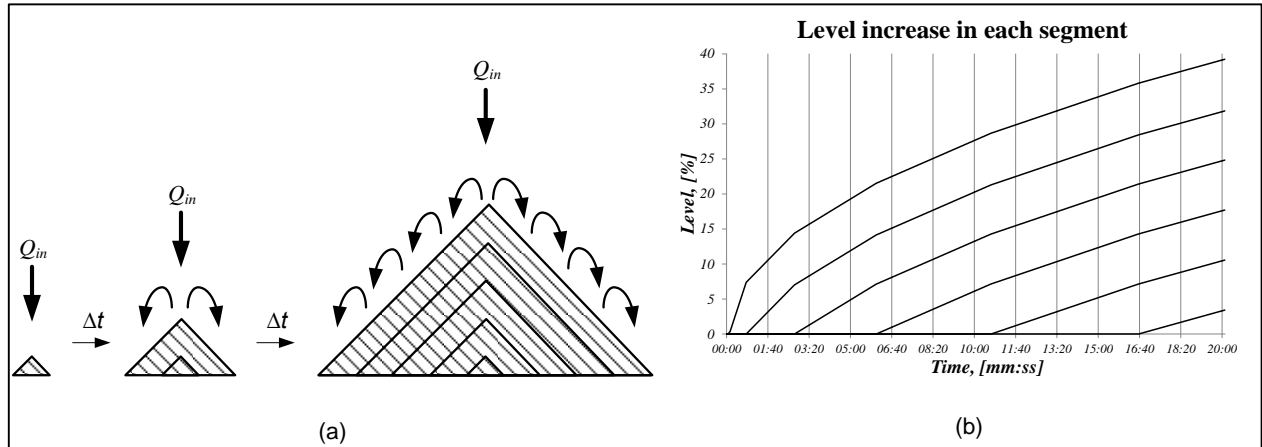

Figure 8. Visual increase in a stockpile at different time steps (Δt) at a constant mass flow (Q_{in}) (a) and data from the simulation given as change in level (y_i) in each section (b).

Plant simulations scenario

To illustrate how the proposed model can be used for dynamic plant simulation a part of an actual platinum plant has been modeled and data from that the plant has been gathered from relevant parameters. The part in question is illustrated in Figure 1 and Figure 2. The bin is a part of the tertiary stage of the crushing plant where it is fed with the coarse material from the grizzly and by the finer re-circulating load. Input variables to the model are based on measured data and can be seen in Table 1

Table 1. Input variables for the model.

Model Specification	Parameter	Value	Unit
Bin Spec	Height - h_a	16.4	m
	Length - l	5.5	m
	Width - w	7.5	m
	Sections - n	10	
	Feed Placement (fine) - $F_{i,1}$	6	
	Feed Placement (Coarse) - $F_{i,2}$	10	
	Product Placement 1 - $P_{i,1}$	3	
	Product Placement 2 - $P_{i,2}$	8	
Material Spec	Product Placement 3 - $P_{i,3}$	13	
	Material Density - ρ	3.21	kg/m ³
	Feed Size Fine - F_{100}	110	mm
	Feed Size Fine - F_{50}	55	mm
	Feed Size Coarse - F_{100}	300	mm
	Feed Size Coarse - F_{50}	160	mm
	Angle of Repose - α	35	degree

A scenario was setup where the three crushers were first run in a sequence and then all together when the bin was at a fairly high level. The level which was logged by the control system can be seen in Figure 9a, as dotted lines.

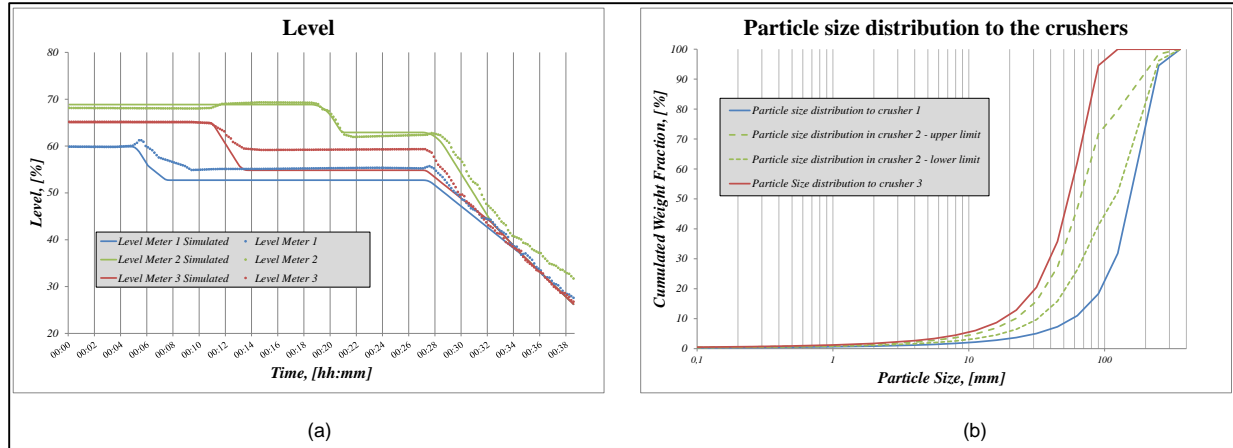

Figure 9. Results from the simulations (solid line) of the change in level (y_i) in sections 3, 8 and 13, together with the corresponding data from the level meters (dots) (refer figure a). The resulting particle size distribution from the bin where crusher 1 and crusher 3 got stable coarse respective fine material (blue and red lines in figure b) while crusher 2 got different composition of the two curves depending on the flow (green dashed line).

In order to simulated this sequences the process readings from the belt scales were copied and imported into the MATLAB/Simulink simulation as well as initial levels at $t=0$. The output used during the simulation is shown in Figure 10.

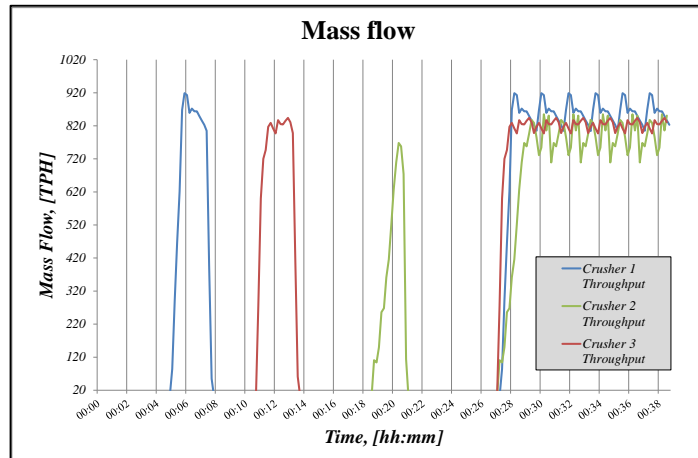

Figure 10. The mass flow (Q_{in}) through the three crushers from the experiment which were imported into the simulation.

The simulated results (solid lines in Figure 9a) correlate well to the logged signals (dotted line in Figure 9 **Error! Reference source not found.**) from the level meters, specially the results from the change in level above crusher 2, red line. The simulation overestimates the change in the level above crusher 1 and 3. This can be due the fact the level meters are not placed directly above the outlet for crushers 1 and 3, but a bit to the side so the change in level will not be as responsive as it were placed directly above the outlet an additional dimension would increase the fidelity of the model. The particles size distribution coming from the bin model will depend on several factors: such as the current levels, the amount of mass coming in and the different feed/product placement. In this scenario, crusher 1 and crusher 3 got the same particle size distribution as was defined into the model. But crusher 2 will have different composition of the two particle size distribution depending on the situation. In Figure 9b the Interval of the feed to crusher 2 is depicted with two green dashed lines, while the particle size distributions for crushers 1 and 3 is constant.

CONCLUSIONS

In this paper, a fundamental model for representing bin behavior has been presented with the aim of being used in dynamic plant simulations. The developed model shows a good potential in mimicking the behavior that can occur in stockpiles and in larger surge bins which are quite usual in a crushing plants where it is a high demand on throughput. Further work is needed to improve the model where factors such as the segregation of the incoming material flow and additional dimension included.

The model implemented into dynamic simulation has proved useful in evaluating possible plant expansion project, where a redesign of a comminution part was commissioned. Different plant setups were simulated under different condition to evaluate the robustness of the future plant

ACKNOWLEDGEMENT

This work has been performed within the Sustainable Production Initiative, and the Production Area of Advance at Chalmers; this support is gratefully acknowledged.

The authors wish to thank the Hesselman Foundation for Scientific Research and the Swedish national research program MinBaS (Minerals, Ballast and dimensional Stone) for its financial support.

Special thanks to Johannes Quist at Chalmers University of Technology and Angus Morrison at University of Cape Town for data collecting, bin measurements and flow analyses used during the model development.

Anglo Platinum and their personnel at Mogalakwena are gratefully acknowledged for all of their support and efforts to make this work possible

REFERENCES

- Asbjörnsson, G., E. Hulthén, *et al* (2012). "Modelling and dynamic simulation of gradual performance deterioration of a crushing circuit – Including time dependence and wear." *Minerals Engineering*(0).
- Asbjörnsson, G., E. Hulthén, *et al* (2012). "Modelling and simulation of dynamic crushing behavior." in a review.
- Engblom, N., H. Saxén, *et al* (2011). "Effects of process parameters and hopper angle on segregation of cohesive ternary powder mixtures in a small scale cylindrical silo." *Advanced Powder Technology* In Press, Corrected Proof.
- Evertsson, C. M. (2000). *Cone Crusher Performance*. Department of Machine and Vehicle Systems. Gothenburg, PhD thesis from Chalmers University of Technology.
- Metcalf, J. R. (1966). "Angle of repose and internal friction." *International Journal of Rock Mechanics and Mining Sciences & Geomechanics Abstracts*3(2): 155-161.
- Schulze, D., Ed. (2008). *Powder and Bulk Solids*, Berlin Heidelberg.

**MODELLING AND SIMULATION OF DYNAMIC CRUSHING PLANT
BEHAVIOUR WITH MATLAB/SIMULINK**

Asbjörnsson, G., Hulthén, E., Evertsson, M., Modelling and Simulation of Dynamic Crushing Plant Behavior with MATLAB/Simulink, Presented at the 8th International Comminution Symposium, 17-20 April 2012, Cape Town, South Africa, Published in Minerals Engineering (Journal), 2013, Volume 43-44, pp 112-120.



Modelling and simulation of dynamic crushing plant behavior with MATLAB/Simulink

Gauti Asbjörnsson*, Erik Hulthén, Magnus Evertsson

Chalmers Rock Processing Research, Chalmers University of Technology, SE41296 Gothenburg, Sweden

ARTICLE INFO

Article history:

Available online 6 November 2012

Keywords:

Modelling
Simulation
Ore handling
Crushing
Screening

ABSTRACT

Every process is subjected to changes in performance and efficiency over time. These dynamics can originate upstream and be inherent through the process or occur anywhere in the downstream process. Traditional plant simulations are performed with steady-state simulation, which are limited to give the performance in an ideal situation. However, plant performance usually tends to deviate away from the predicted plant performance. These dynamics are usually consequences of an altered state of the plant due to factors such as natural variation, unmatched, inappropriate or degrading equipment performance and/or stochastic events.

This paper presents a novel approach for simulating dynamic plant behavior and evaluating effects from process modification through dynamic simulations with MATLAB/Simulink. An example of an existing crushing circuit is used to illustrate the functionality and the advantage of using a dynamic simulator. The results and knowledge gained from the simulation can provide a base for optimizing a robust production output in the form optimal utilization, energy efficiency or higher product quality.

© 2013 Published by Elsevier Ltd.

1. Introduction

Crushing plant's design rely on accurate plant simulations. Crushing plants are designed to be able to produce certain throughput on predefined specification (i.e. a certain particle size distribution) and a certain particle size distribution while operating at a reasonable cost and at efficient energy consumption.

Equipment manufactures as well as plant designers use software packages for predicting the plant performance. There are a number of software packages available that are able to predict plant performance. The most widely used type of simulations is steady state simulations, meaning that the system is considered to be at equilibrium with all time derivatives exactly zero. Examples of steady state simulation packages include: Plantdesigner (Sandvik), Bruno (Metso), JKSimMet (JKSimMet), Aggflow (BedRock Solution) and UsimPac (Caspeo).

An interest in more dynamic simulations has been growing in minerals processing (Napier-Munn and Lynch, 1992; Liu and Spencer, 2004; Smith, 2005; Reynolds, 2010). Examples of available software that can perform dynamic simulations include Simulink (Mathworks) SysCAD (Kenwalt), Aspen Dynamics (Aspentech) and Dymola (Dassault Systèmes). Even though plants experience a steady-state condition under certain circumstances, it is inaccurate to assume that the system is steady under all circumstances. It

is the authors' opinion that crushing plants seldom operate under steady conditions during longer time periods. Crushing is a continuous process; as a continuous system, equipment is subjected to variations and changes over time. These variations can be caused by: natural variation, unmatched, inappropriate or degrading equipment performance, stochastic events and more which are common in daily operations.

A development of a simulator which is capable of representing the dynamic behavior in crushing plant is ongoing at Chalmers University of Technology. The purpose of the simulator is to get more detailed simulation tool which can be used for: evaluating plant performance, control development and operator training. This paper aims to describe the developed simulator and the methodology for evaluating dynamic plant performance by introducing mechanical process modifications. All models and layouts have been modelled using the MATLAB/Simulink software.

2. Method

Crushing plants like any other production process are affected by changes over time. To be able to predict the dynamic behavior of any system an understanding about the entities and interaction there in between is essential. System complexity is depending on the level of detail. Simple models are single input single output (SISO) but that is seldom the case in reality, actual systems are often complex with multiple input, where an output (variable x) is linked to multiple input variables (u_1, \dots, u_n) and internal

* Corresponding author. Tel.: +46 708 876 867.

E-mail address: gauti@chalmers.se (G. Asbjörnsson).

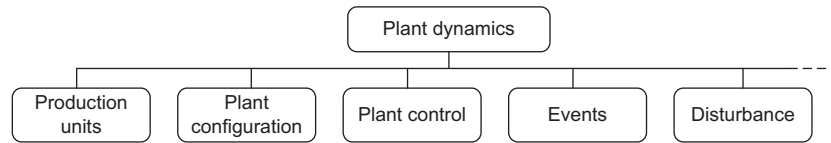

Fig. 1. Factor influencing plant dynamics.

variables (x_1, \dots, x_n) which are time dependent (t) , (Ljung and Glad, 2002) (Eq. (1)).

$$\frac{dx}{dt} = f(x_1(t), \dots, x_n(t), u_1(t), \dots, u_n(t)) \quad (1)$$

Plant dynamics is a complex phenomenon where correlation and casualization can be vague. To simulate plant dynamics mathematical models for every production unit, e.g. crushers, screens, conveyors, silos, etc., has to be created. The models describe the changes in flow and particle size of the material traveling through the plant. Plant simulations generally only focus on the production unit and plant configuration, but due to accumulation of material the flow needs to be controlled in dynamic simulations. Additionally the process can be sensitive to startups, discrete events, wear, segregation, natural variation and more which is not uncommon in operation, all depending on interaction between single production units, plant configuration, plant control and diverse events and disturbances that can influence the process, see Fig. 1.

2.1. Frame of references

Factors that influence production unit performance are well documented both for specific production units and for material handling. According to Svedensten (2007) the change in performance due to wear differs greatly depending on the application, feed material and equipment. Any material that comes in contact with another material experiences wear in one form or another. Crushing performance and the effects of wear on cone crusher have been described in detail by Evertsson (2000) and Lindqvist (2005). Due to wear the geometry of the liner will change gradually during the lifetime of the liners, causing changes in crusher capacity and particle size distribution of the crushed material. Related studies have been performed for primary crushers, both Jaw crushers Lindqvist (2005), and gyratory crushers Rosario et al. (2004).

Screen performance has been described by Stafhammar (2002) and Karra (1979) but not with any specific focus on wear. Screen decks are constantly subjected abrasive wear due to the relative motion of the rock material. The wear rate on the screening media all depends on what type of screening media is used and the characteristics of the rock. Over time the aperture of the screening media will increase due to wear and by that enabling larger rock to travel through the screening decks.

Another factor that can decrease predicted plant performance is inadequate bulk material handling. Material flows in bins where there are multiple inflows and multiple outflows can cause problem in the downstream process due to segregation within the bin. There are documented cases (Powell et al., 2011) where realigning and redistributing of material entering larger bins have resulted in a higher plant capacity and more even operation.

Predict variations in a dynamic plant simulations is difficult and the variations are everywhere, both in the production units and the rock material itself (Robinson, 2003). The properties and characteristics of the rock material entering the circuit will affect the plant performance depending on the situation. Changes in mineral content, particle size distribution and moisture have been document to have a direct influence on the wear rate and performance in crushers and screens (Stafhammar, 2002; Lindqvist, 2005).

Variations also make it difficult for validating plant simulations results to plant measurements. Continuous monitoring can provide helpful information about the process variation but certain information can still only be gathered with manual sampling from the process. This is not ideal as the samples are relatively small compared to the amount of processed material and only reflects a momentary state at a certain part of the process.

Every production process experiences dynamic behavior as a result from the process control counteracting the effects from dynamic disturbances. The level of control is depending on the complexity of the process and the control system designer's ability in providing appropriate solution to the task. Most crushing plants are equipped with some sort of basic regulatory control operating under a supervisory control. Dynamic simulators have been used for years in control development and verification in many industries (Rajamani and Herbst, 1991; Marlin, 2000).

3. Modelling

In order to simulate an entire system, a plant, the models are connected together according to the user preference and configured with a set of defined parameters. The models share the same type of connection, so any unit can be connected together with ease and material properties are inherent for subsequent units. The modelling has been done by using MATLAB/Simulink.

Simulink is a commercial simulation software developed for simulating and analyzing dynamic and discrete systems, which is widely used within industry as well as within academia for representing process behavior and control systems. Simulink provides a graphical programming user interface for block-oriented modelling. A custom library has been developed, by the authors, for equipment representation, see Fig. 2.

Any equipment is subjected to change in performance in way or another and in many cases it is due to accumulation of mass and change of settings. Every process unit model is therefore equipped with ordinary differential equation (ODE) for keeping track of the material in the process (Eq. (2)).

$$x(t) = x_{t_0} + \int_{t_0}^t (u_{in}(t) - u_{out}(t)) dt \quad (2)$$

Due to this the material travelling through the plant will experience delays in all equipment, as described by Sbarbaro (2010). The conveyors are modelled as pure delays (t_{delay}) , which is dependent on conveyor length and speed (Eq. (3)). Screens were modelled with a constant delay which depends on the size of the screen.

$$x(t) = u(t - t_{delay}) \quad (3)$$

In the crushers the material accumulates in a perfect-mixed model where the level is function of crusher geometry and mass flow. In larger bins, due to the bin geometry of the bins, the material can be segregated between coarser and finer particles. Vertically separated section in bins was modelled with flow distributed depending on the level in each section and angle of repose to enable vertical segregation within the bin. The accumulated material is perfectly mixed in each section.

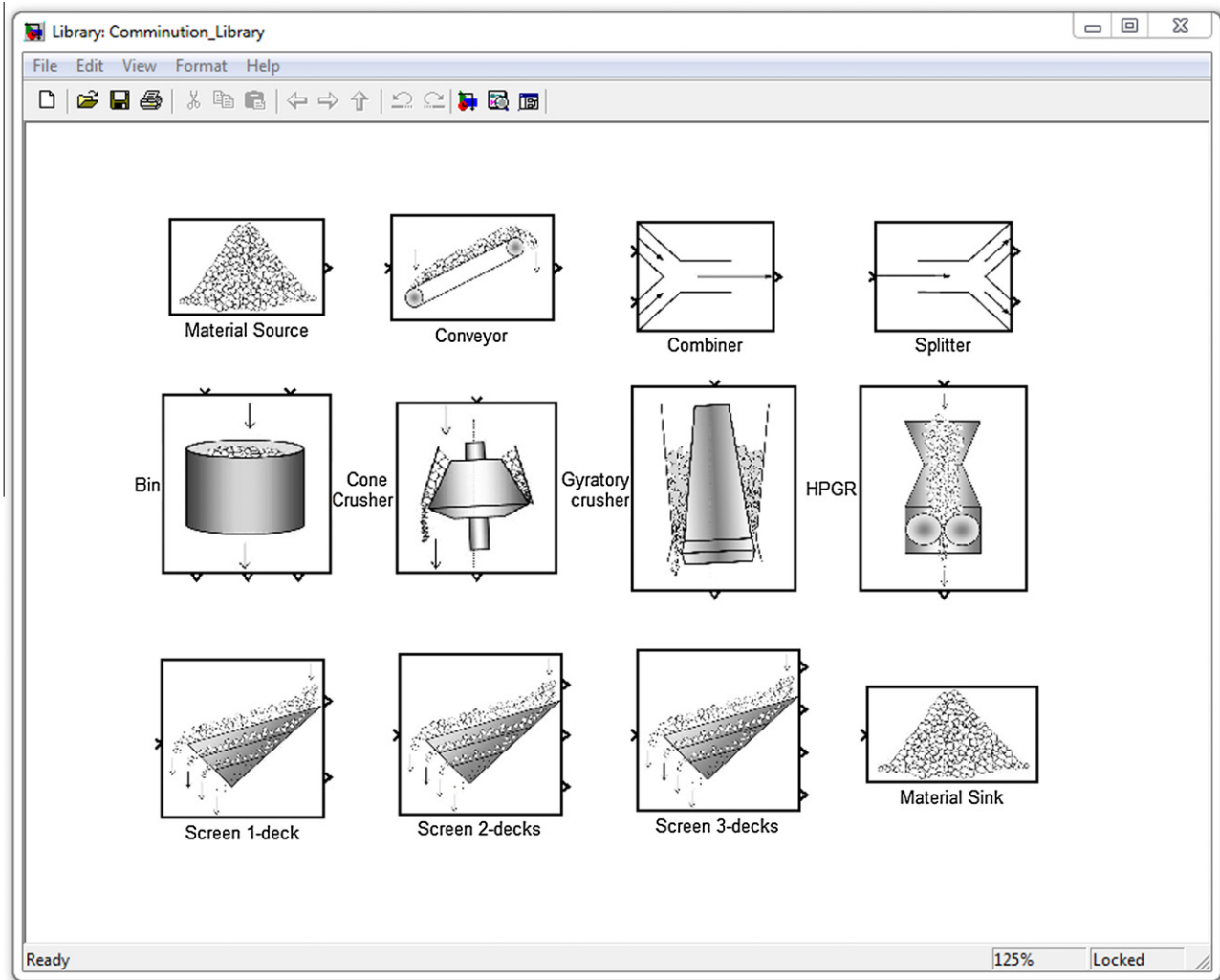

Fig. 2. Custom library in Simulink developed by the authors.

The crusher will not operate efficiently until it has achieved choking condition. The transient response behavior in the crusher throughput is modelled as a function of the level in the hopper and the estimated maximum capacity ($Capacity_{max}$) under given operating condition. Estimation of the actual capacity with regards to level of the accumulated mass in the hopper is given by Eq. (4), where $u(t)$ is a variable representing the level in the hopper, $Level_{choke}$ is a parameter where the capacity of the crusher is at maximum above that level and $Capacity_{max}$ is the crusher's maximum capacity.

$$y(t) = Capacity_{max}(1 - e^{Level_{choke} * u(t)}) \quad (4)$$

First order transfer functions ($G(s)$) were implemented in the feeder models to model feeder response to change in operation (Eq. (5)). The feeder models are a sub-system to the bin and material source models shown in Fig. 2. Where T is the time constant and s is the Laplace operator.

$$G(s) = \frac{Y(s)}{U(s)} = \frac{1}{Ts + 1} \quad (5)$$

The crusher performance used in this study is based on the crusher performance at survey performed prior to the simulation study at the reference plant. The gathered data was empirically fitted to a modified Swabrec function which has been used in previous project (Asbjörnsson et al., 2012) to enable interpolation of the

data sets and to characterize the change in breakage with regards to changed feed size composition and machine settings. The screen model used in this study is the Karra model which has been used in both dynamic and steady state process simulations (Lynch, 1977), with an empirically fitted efficiency curve.

Different types of regulatory controllers are used throughout comminution plants depending on the plant layout, operation and objectives. The general purpose of any control system is to manipulate variables to compensate for the changes in the process due to effects from disturbances, see Fig. 3. The regulatory control

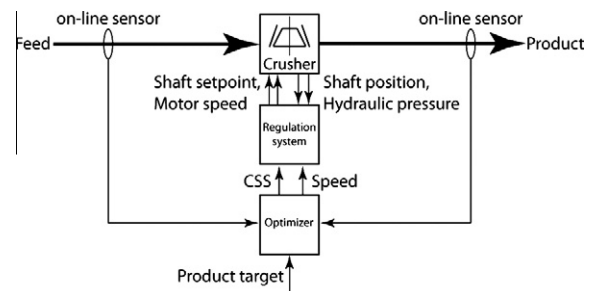

Fig. 3. A closed loop process control for cone crusher as presented by Hulthén (2010).

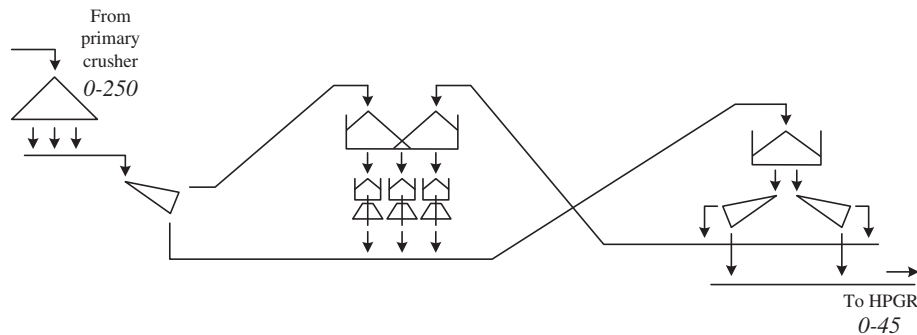

Fig. 4. The dry section of a large mineral processing plant.

was modelled into simulation with built-in blocks from the Simulink library for overseeing the material flow.

4. Simulation

To illustrate the possibilities with dynamic simulation a reference plant was modelled. This particular section shown in Fig. 4 displays the dry section of an actual platinum plant. This plant was designed to be able to handle 1400 TPH but due to number of factors the plant is only able to handle in average 700–1200 TPH. A steady-state simulation did not give any indication of problems with the process, probably since the three crushers are all fed from the same source of material and even distribution assumed to be the crushers. The modelled section is equipped with three Sandvik CH880 cone crusher, single vibrating grizzly with slot width from 80 mm, two double deck Vibromech screens with top deck at 85×85 mm and bottom deck at 40×52 mm and two bins that are approximately 660 m^3 and 300 m^3 , respectively. The purpose of the simulation is to validate how different configuration of selected production units can increase the maximum overall capacity.

4.1. Identifying bottlenecks

General aspects that can cause discrete or gradual changes in the process are summarized in Fig. 5. This is although not a complete list and aspects are not ranked in any specific order. How these aspects affect the production units and/or the process itself is application dependent.

Identifying problems and debottlenecking an existing process is challenging and requires detailed information from the process and how it is controlled. In an open circuit the bottleneck is usually the last production unit to ensure constant output from the plant but with closed circuit the configuration can cause problems. Identifying problems can often be done by manually studying the raw data from the plant's SCADA system, but this is although time consuming process and will not always guarantee results.

The underlying reasons for the low throughput were identified to originate in the stockpile feeders located on the far left in Fig. 4. First the feeders under the stockpile have the maximum capacity around 1400 TPH but they are often regulated down to even out the flow and secondly the feeders are shut off, which is a bigger problem. The feeders can be manually shutoff from the plant SCADA system or by the interlock in the control system. Processing the data from the plant and control algorithms from that plant revealed that the surge bin capacity plays an important role for plant as when the bins reach high level the interlock shuts off the feeders. Due to a combined problem caused by the bin geometry, control and variations the crusher bin (located in the middle in Fig. 4) it is unable to uphold a stable process and act as an appropriate buffer for the process. Due to length of the plant and configuration the

plant wide control system shuts off the feed into the circuit to avoid overflow in the two bins.

4.2. Modelling the plant

The initial phase is to model the plant using the custom build blocks and connect in an appropriate way, see Fig. 6. Plant model was populated using data from a crushing survey performed at this particular plant. Crushers, screens, grizzly and bins were calibrated to represent the process behavior as close as possible.

In order to regulate the plant, single unit controllers and plant wide control were set up. PID controllers were modelled in the feeders above the screens that were regulated with the level in the screen bin and in the feeders above the crusher to regulate the level in the crusher hopper, PID controller were calibrated to react in the same manner as the actual PID's. All interlocks and control limits for this particular section were programmed for the plant to avoid overloading.

4.3. Configuring the simulation

As the purpose of the simulation is to validate if different configuration of selected production units could increase the maximum overall capacity the simulations were configured with regards to these constraints. A reference plant simulation was configured to represent the performance of the actual process. No events were included in these particular scenarios as it would not contribute to any significant difference between the scenarios. The variation in the incoming feed was analyzed; both varying particle size distribution and the total amount of material and included in the simulation as disturbances. The feed size distribution can be seen in Fig. 7.

Four different scenarios were simulated to evaluate if the overall capacity could be increased by altering the plant configuration. All four scenarios were simulated under different loads to evaluate when the plant would reach performance saturation. The manipulating variables were selected from systematically valuating the effort of change and probability of increased output with the support of data from the crushing survey, equipment specification and the diagrams illustrated in Figs. 4 and 6. The factors varied in the simulation scenarios were following:

- Varying the mass and particle size distribution of the incoming material into the circuit.
- Reducing the Closed Side of the coarse crusher (located on the far left in Fig. 4), from 55 mm to 40 mm.
- Increasing the throw in fine crusher (located on the far right in Fig. 4) from 38 mm to 44 mm.

Additional factors were considered but these were considered to have the largest probability in increasing the throughput with-

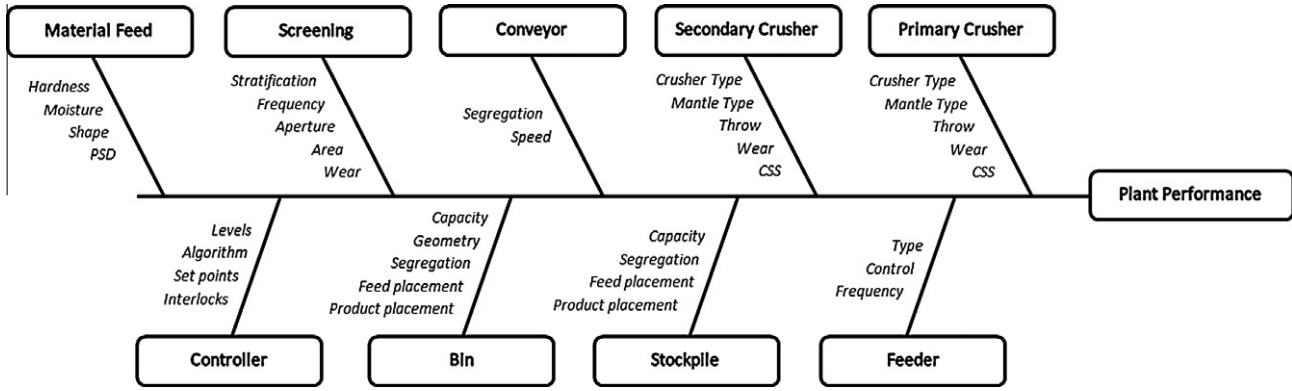

Fig. 5. Illustrating factors that can cause changes in plant performance.

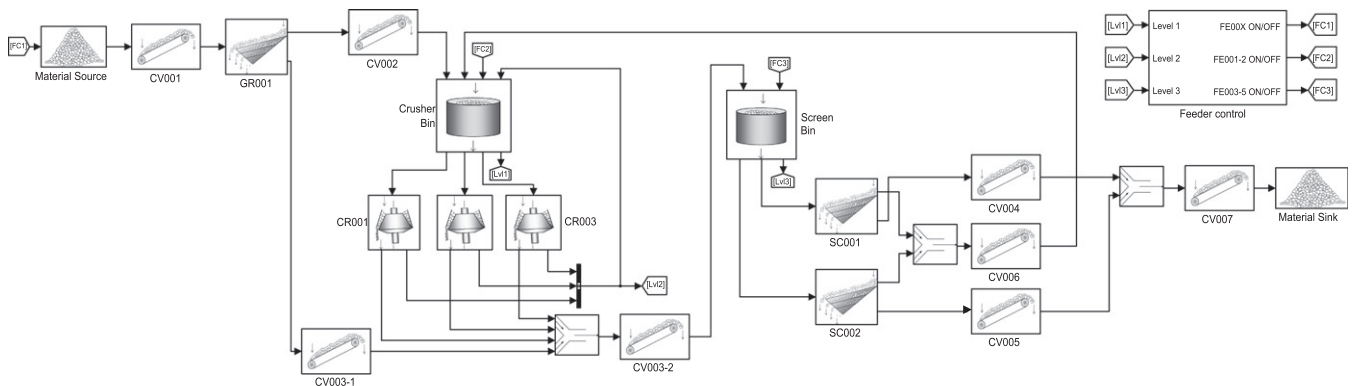

Fig. 6. The section from Fig. 6 modelled in MATLAB/Simulink.

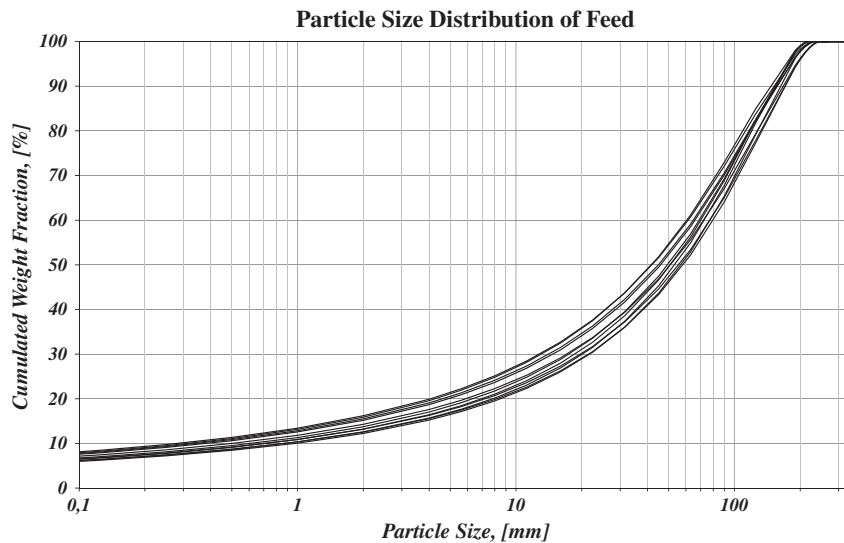

Fig. 7. Generated feed curves to the plant simulation. F_{100} is varied between 210 and 250 mm while F_{50} is varied between 40 and 60 mm.

out affecting the downstream process in a negative way. The scenarios were set up as following:

- Scenario 1. Reference simulation, only amount of incoming feed varied.
- Scenario 2. Feed varied and CSS on coarse crusher reduced.
- Scenario 3. Feed varied and the throw on the fine crusher increased.

Scenario 4. Feed varied, CSS on the coarse crusher reduced and throw on the fine crusher increased.

4.4. Simulation results

The simulations show that the plant operates in efficiently during a lower load (1250 TPH shown in Fig. 8 for Scenario 1), making it easier for the control system to keep the process stable. When

the mass flow, fed into the circuit, is increase the plant starts to experiencing fluctuation (1500 TPH shown in Fig. 9 for scenario 1).

The first graph in Figs. 8 and 9 shows the mass flow after the stockpile. The second graph is the mass flow after the three crushers. The third and the fourth graph is the mass flow after the screen, for over respective under size. Fifth graph illustrates the different levels in the crusher bin (above the fine crusher and the coarse crusher) and the sixth graph is the change in level for the screen bin.

The simulations revealed that the plant reaches performance saturation at a particular point depending on how it is configured, see Fig. 10. In a simple open circuit system increasing the capacity of the production unit causing the bottleneck would directly correlate to increase in the plant performance but as for Scenario 2 by reducing the capacity of the course crusher by reducing the CSS the overall plant performance is increased by 4.7%. Due to the configuration of production units and the control system the effects of manipulating the configuration is hard to predict in advance.

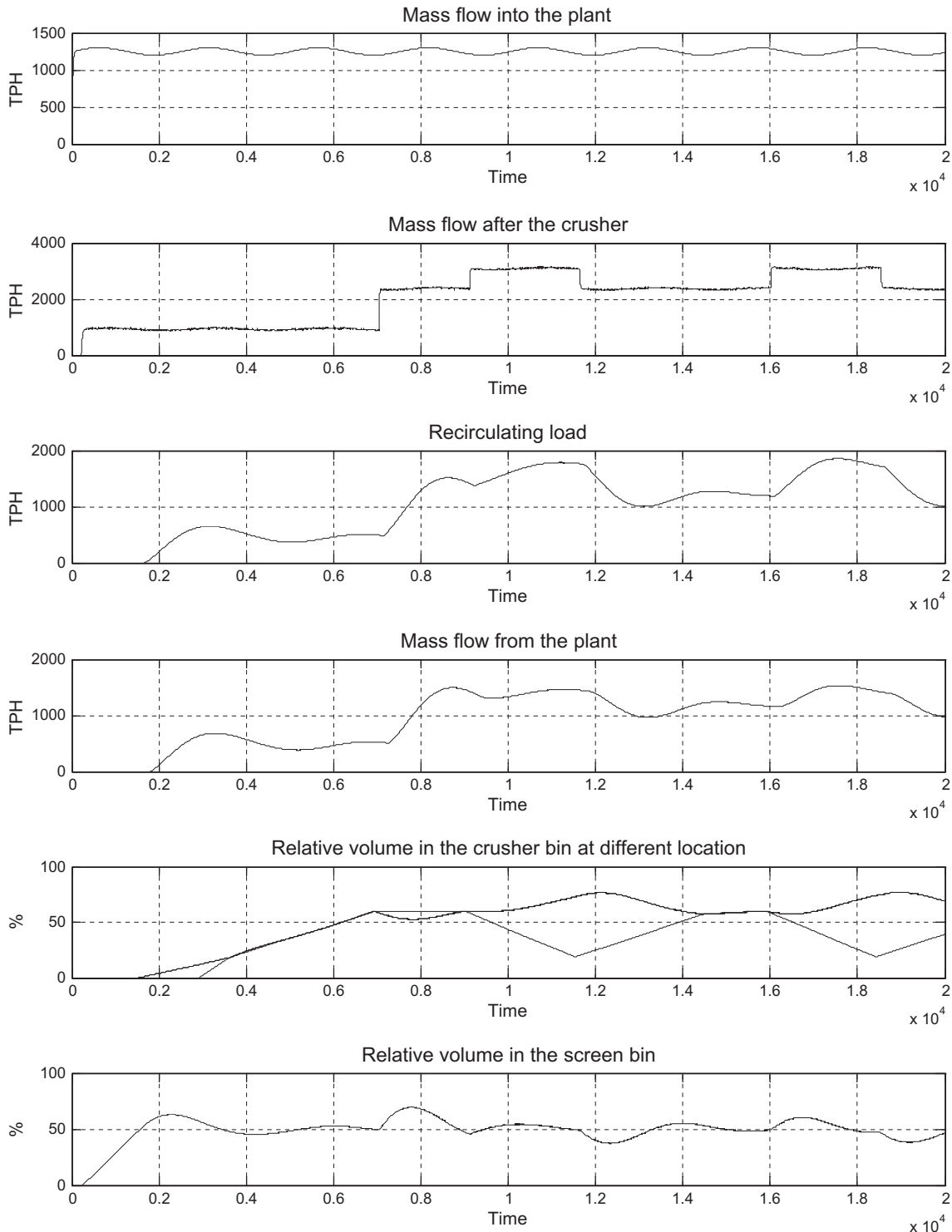

Fig. 8. Simulation results from simulating 1250 TPH in scenario 1.

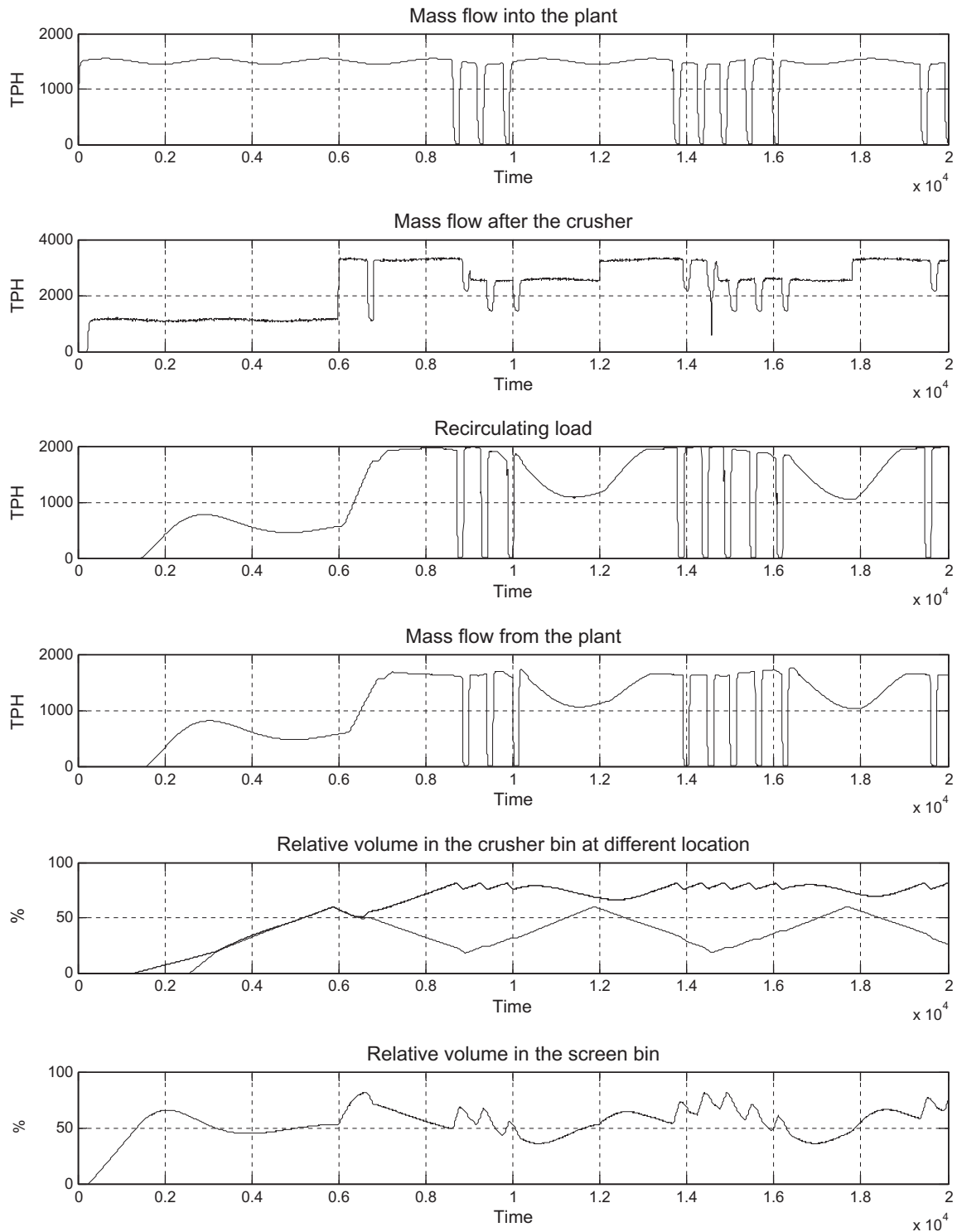

Fig. 9. Simulation results from simulating 1500 TPH in scenario 1.

The simulation scenarios in Fig. 10 illustrate how the process is at a stable condition until it reaches a critical saturation point. This is where the interlocks start interrupting the process and cutting of the incoming feed into the circuit. Upper and lower variation lines represent one standard deviation of the plant performance. The reference scenario (scenario 1) was able to produce approximately 1275 TPH in an uninterrupted operation. Scenarios 2 and scenario 3 were able to increase the overall capacity with 4.7% resp. 8.2%. The combined factors in Scenario 4 revealed a possible 13.3% increase in plant capacity.

5. Validation

The simulation results were validated with actual process modifications with the suggested changes. The process modifications were made and the process allowed to normalize. The process performance was later analyzed from when the process is operating. Increasing the throw of crusher 3 from 38 mm to 44 mm, enabled higher capacity of that particular crusher and better equipped it to handle the amount of recirculating load. By increasing the throw the plant was able to process approximately 1351

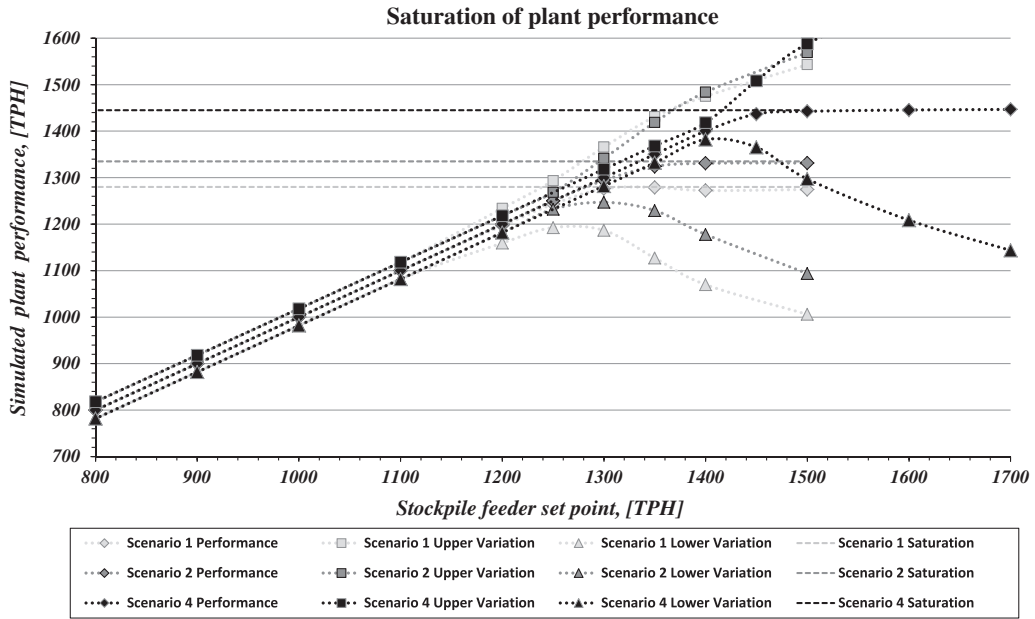

Fig. 10. Performance saturation under different conditions.

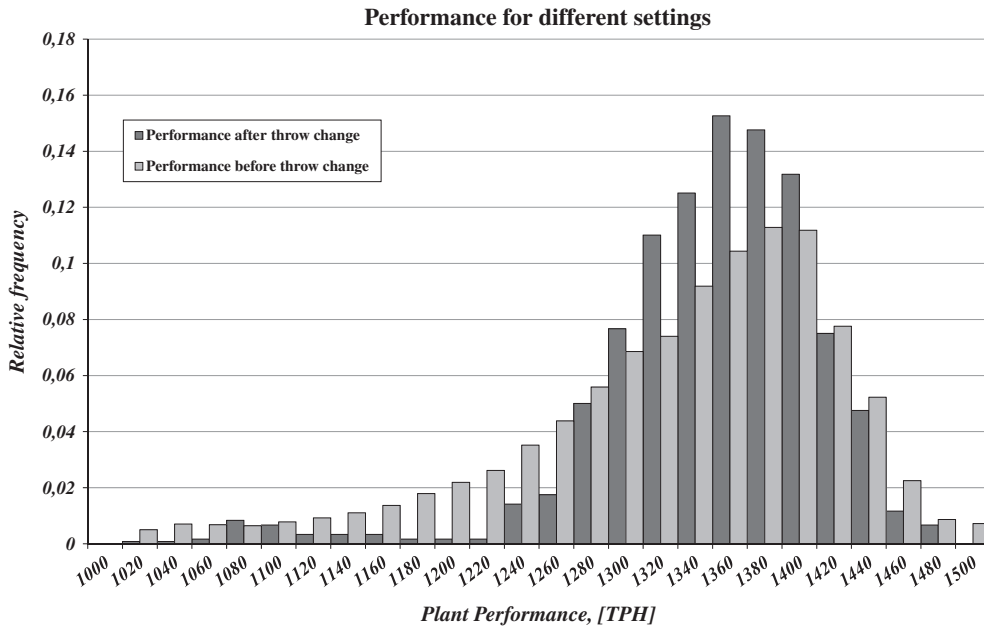

Fig. 11. The plant operating under similar condition at two different throws for crusher 3.

TPH on average from a previously 1330 TPH, an increase of 1.6% while operating the crusher at the same close site settings (see Fig. 11). The tail of the histogram in Fig. 11 is a clear indication of the effect from the control system regulating down the flow to relieve pressure from the circuit to minimize the risk of overload. It is although difficult to prove the significance of these results as the two tests were performed with a month in between so while the crusher are operating at a similar settings other factor in the process have changed.

Operating the crushers 1 and 3 at different close side settings, from larger settings at 65 mm resp. 25 to smaller settings at 50 mm resp. 20 mm for crushers 1 and 3 (see Fig. 12) showed an increase in the plant performance. An increase of approximately

4.9% was achieved, from 1291 TPH to 1354 TPH. At larger settings the amount of circulating load is enough to cause the control system to actively interfere with the stockpile feeders.

6. Conclusions

As can be seen in the plant example it was demonstrated that for this particular plant the plant reaches performance saturation under specific load. By evaluating and simulating process modification the theoretical plant performance was increased by up to 13.3%. The empirical test revealed increased plant performance of the magnitude of 1.6% resp 4.9% for the two different scenarios, increasing the actual maximum plant performance.

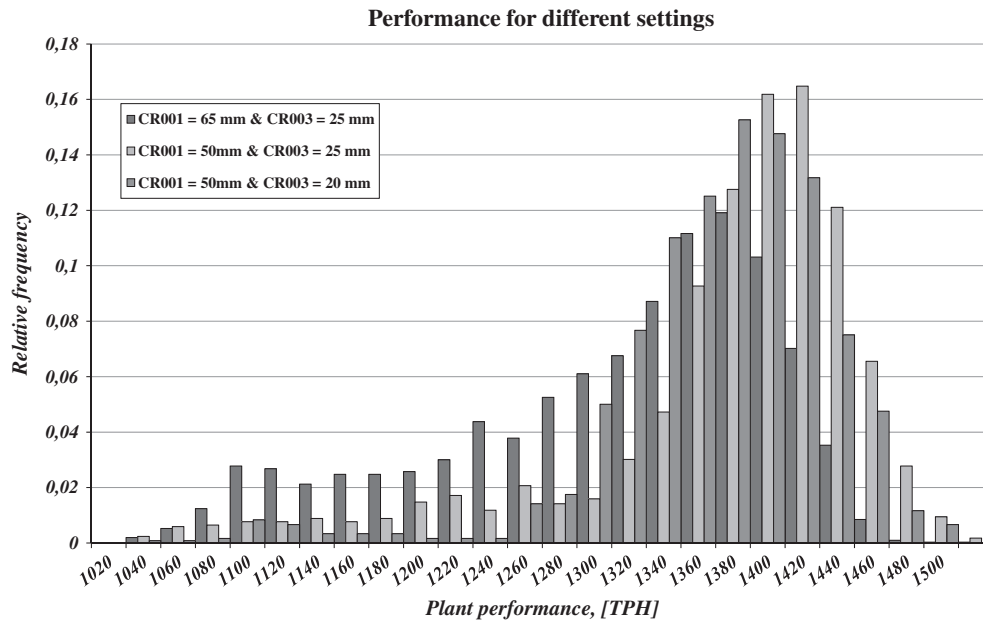

Fig. 12. The plant operated under similar conditions while crushers 1 and 3 are at different close side settings.

One of the main sources of dynamics in the simulation was caused by material flow in the bin above the crushers, which was also observed in the production data. In the scope of this work the focus was to simulate these dynamic effects in the production by mechanical process modifications. Further analyses should be done with a focus on the control loops where regulatory control loops are tuned, different supervisory control algorithms tested and more disturbances included.

In this paper, it has been demonstrated how dynamic plant simulations can be utilized for representing dynamic plant performance and for evaluating effects from process modification. Even though dynamic plant simulations are more complicated than a steady state simulation, they do have a higher potential in predicting the actual plant performance. The developed simulator used during this work has proven useful in giving more comprehensive information about the process to the user.

Acknowledgements

This work has been performed within the Sustainable Production Initiative and the Production Area of Advance at Chalmers; this support is gratefully acknowledged.

The authors wish to thank the Hesselman Foundation for Scientific Research and the Swedish national research program MinBaS (Minerals, Ballast and dimensional Stone) for its financial support.

Anglo Platinum and their personnel at Mogalakwena are gratefully acknowledged for all of their support and efforts to make this work possible.

References

Asbjörnsson, G.E., Hulthén, et al., 2012. Modelling and dynamic simulation of gradual performance deterioration of a crushing circuit – including time dependence and wear. *Minerals Engineering* (0).

- Evertsson, C.M., 2000. Cone Crusher Performance. Department of Machine and Vehicle Systems. Gothenburg, PhD Thesis from Chalmers University of Technology.
- Hulthén, E., 2010. Real-Time Optimization of Cone Crushers. Department of Product and Production Development. Gothenburg, PhD Thesis from Chalmers University of Technology.
- Karra, V.K., 1979. Development of a model for predicting the screening performance of a vibrating screen. *CIM Bulletin* 72, 167–171.
- Lindqvist, M., 2005. Wear in Cone Crusher Chambers. Department of Applied Mechanics. Gothenburg, PhD Thesis from Chalmers University of Technology.
- Liu, Y., Spencer, S., 2004. Dynamic simulation of grinding circuits. *Minerals Engineering* 17 (11–12), 1189–1198.
- Ljung, L., Glad, T. (Eds.), 2002. *Modelling of Dynamic Systems*. Prentice Hall Information and System Sciences, Prentice Hall Inc.
- Lynch, A.J. (Ed.), 1977. *Mineral Crushing And Grinding Circuits – Their Simulation, Optimisation, Design and Control*, Developments in Mineral Processing. Elsevier Scientific Publishing Company.
- Marlin, T.E. (Ed.), 2000. *Process Control – Designing Processes and Control Systems for Dynamic Performance*. McGraw-Hill Chemical Engineering, McGraw-Hill Inc.
- Napier-Munn, T.J., Lynch, A.J., 1992. The modelling and computer simulation of mineral treatment processes – current status and future trends. *Minerals Engineering* 5 (2), 143–167.
- Powell, M.S., Benzer, H., et al., 2011. Transforming the Effectiveness of a HPCR Circuit at Anglo Platinum Mogalakwena. SAG.
- Rajamani, R.K., Herbst, J.A., 1991. Optimal control of a ball mill grinding circuit—I. Grinding circuit modeling and dynamic simulation. *Chemical Engineering Science* 46 (3), 861–870.
- Reynolds, B., 2010. Dynamic Simulation of an Alumina Refinery XXV International Mineral Processing Congress. Brisbane, Australia.
- Robinson, G.K., 2003. Predicting variation in planned mineral processing plants. *Minerals Engineering* 16 (3), 179–186.
- Rosario, P.P., Hall, R.A., et al., 2004. Liner wear and performance investigation of primary gyratory crushers. *Minerals Engineering* 17 (11–12), 1241–1254.
- Sbarbaro, D., 2010. Dynamic simulation and model-based control system design for comminution Circuits. *Advanced Control and Supervision of Mineral Processing Plants*. Springer, London, pp. 213–247.
- Smith, H., 2005. Process Simulation and Modelling. *Developments in Mineral Processing*. In: Mike, D.A., Wills, B.A. (Eds.), 15. Elsevier, pp. 109–121.
- Staffhammar, M.S., 2002. Screening of Crushed Rock Material. Department of Machine and Vehicle Systems. Gothenburg, PhD thesis from Chalmers University of Technology.
- Svedensten, P., 2007. Crushing Plant Performance. Department of Applied Mechanics. Gothenburg, PhD thesis from Chalmers University of Technology.

TUNING OF REAL-TIME ALGORITHM FOR CRUSHING PLANT USING A DYNAMIC CRUSHING PLANT SIMULATOR

Hulthén, E., Asbjörnsson, G. and Evertsson, C. M., Tuning of Real-Time Algorithm for Crushing Plants Using a Dynamic Crushing Plant Simulator. Presented at the 8th International Comminution Symposium, 17-20 April 2012, Cape Town, South Africa, Published in the conference proceedings.

TUNING OF REAL-TIME ALGORITHM FOR CRUSHING PLANTS USING A DYNAMIC CRUSHING PLANT SIMULATOR

Erik Hulthén, PhD., Gauti Asbjörnsson, M.Sc., Magnus Evertsson, PhD.*

Chalmers Rock Processing Research, Chalmers University of Technology, SE-41296 Gothenburg, Sweden

**Corresponding author: erik.hulthen@chalmers.se*

Abstract

Real-time algorithms have earlier been successfully implemented in crushing plants for the selection of set-points. The algorithms build on principle models of how the on-line adjustable parameters affect the process. The dynamics in a crushing plant are usually consequences of altered states of the plant due to factors such as natural variation of the processed material, degrading equipment performance and more or less stochastic discrete events. Although the real-time algorithms are carefully designed in order to optimize the process, they are not fine-tuned themselves.

In this paper a method for tuning real-time algorithms using a dynamic crushing plant simulator is presented. With the plant realistically modeled in a dynamic simulator the constants of the real-time algorithm can be selected before the algorithm is implemented in a real plant. Thus the algorithm can optimize the plant better and quicker. The method is demonstrated with a simulation of a real crushing plant.

Keywords: Real-Time algorithm, Dynamic simulation, Modeling, Comminution

Introduction

In crushing plants, both in the mining, minerals and aggregates industries, cone crushers are used for size reduction of rock materials into finer fractions. Their main operating principle is the same today as when first developed over a century ago. A mantle rotates and moves eccentrically in the crushing chamber and the rock material is crushed between the mantle and the concave several times while falling downwards through the crusher. As the mantle and concave surfaces become worn, the distance between them must be adjusted to maintain the reduction ratio and control the top size of the product. This distance is measured at the outlet of the crushing chamber and is called Closed Side Setting (CSS). Another parameter of a cone crusher, the eccentric speed, has a great impact on the product properties. The explanation is that the speed affects the number of compressions that the material is exposed to and thus the particle-size distribution of the product. Capacity is affected by the speed, especially on the Simons type of crushers. Whereas changing the CSS moves the product cumulative particle-size-distribution curve horizontally, changing the eccentric speed tends to rotate it. The eccentric speed of a cone crusher can be changed continuously and easily by applying a frequency converter. These have decreased in cost in recent years, making them more available for use in standard crushing applications.

Practical crushing operations encounter a wide range of variables: natural variations of the rock-material properties in the feed, wear of the equipment, weather, unwanted stops, etc. So, when implementing

real-time control of several parameters on a crushing plant, monitoring of the status of the actual process is crucial. A standard conveyor-belt scale, for instance, can easily transmit information about the mass flow to a computer. A more cost-effective way of measuring the current capacity is to measure the power draw on a conveyor belt that is performing a lifting work (Hulthén and Evertsson 2006). Such a measurement device can be obtained for a tenth of the cost of a traditional belt scale.

Earlier work

The authors previously showed that a crusher with an automatic-setting regulation can be improved by implementing a closed-loop feedback from the process; this was done with a Finite State Algorithm (FSM) and the improvement was 3.5% (Hulthén and Evertsson 2009). In a following work, the authors implemented a real-time optimization of a cone crusher without a control system for CSS by instead controlling the eccentric speed dynamically (Hulthén and Evertsson 2008), still with an FSM. This improved the output from the crushing stage by 4.2%. In a subsequent study, the setting and the eccentric speed parameters were combined and formed a model which predicts the output from the crushing stage (Hulthén and Evertsson 2010). The model was then used in designing an algorithm which improved the process by 6.9%. However, this algorithm assumes that the constants of the model are kept updated. It cannot be assumed that the constants have the same values on other crushing stages, thus it must be re-fitted again and again.

The authors have successfully modelled the dynamic behaviour in crushing plants. In (Asbjörnsson, Hulthén et al. 2012) a wear function was introduced in a dynamic simulation of a Symon's type of crusher with deteriorating performances due to wear and lack of adjustment possibilities. In (Asbjörnsson, Hulthén et al. 2012) a crushing section including PID control loops and interlocks of a minerals processing plant was modelled for investigating potential process improvements. Empirical experiment at the plant confirmed the simulated process adjustments with good accuracy.

Problem

Control of eccentric speed is motivated by the non-fixed conditions under which a crusher operates. The crusher can be operated at different eccentric speeds in order to compensate for wear (when there is no crusher setting control), raw material variations, and wear-related crushing chamber changes during its lifetime. A Finite State Machine (FSM) algorithm has been developed. A simple variant of FSM called the Mealy machine (Mealy 1955) is used, in which actions only take place on the entry of a state. The exit of a state is conditioned but brings no actions. The FSM was developed manually (in contrast to a computer-generated algorithm) in (Hulthén and Evertsson 2008) to find a speed close to the optimal value and to stay at that speed for a time period. The structure of the developed FSM is shown in Figure 1.

The design and tuning of the FSM algorithm is done manually. This is a time consuming work in itself, but bearing in mind that the algorithm needs to be tuned at each plant makes it even more time consuming. There is a desire for the tuning, and hopefully also the design in the future, to automatic. The question in this paper is therefore, is it possible to tune an FSM algorithm effectively and automatically?

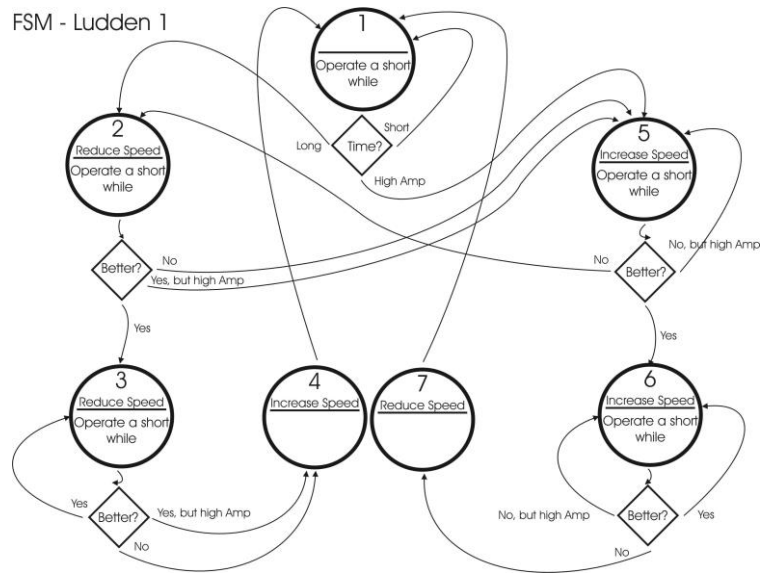

Figure 1. The Finite State Machine (FSM) which is used for selecting the speed on the crusher.

Method

Dynamic Simulator for Crushing Plants

The Dynamic Simulator used in this study was developed in MaATLAB/Simulink by the authors in earlier papers. The simulator was developed to represent the process more accurately than traditional simulation software in order to study the dynamics of the process. Each production unit is defined with multiple mathematical equations to describe how it affects the material, how material accumulates within the system and to describe equipment's transient behaviour.

A plant is modelled by arranging different equipment models in an appropriate sequence and connecting them together, as illustrated in Figure 3. Implementing controllers are essential for the process simulation as the material will continue to accumulate even after it has reached the volume capacity of that particular production unit. This can be done by adding a PID controller on the feeders for regulating the mass flow from the units.

The main reason why fixed settings are not optimal is that several factors in crushing plants vary with time. In addition to the short-term wear period of the crushing chamber discussed above, the factors that are beyond operator control are raw-material variation, screen-cloth wear, and total crushing-chamber wear over its useful lifetime.

Optimization with a genetic algorithm

For the optimization of the FSM algorithm an evolutionary algorithm called genetic algorithm (GA) is used. In a GA, a candidate solution to the problem at hand is represented as a fixed-length string of digits known as a chromosome. The chromosome, when decoded, generates an individual (in this case the parameter values in the FSM), which can be evaluated and assigned a fitness score based on its performance. In the evolution of the optimal settings for an FSM for a specific crushing plant, the fitness measure can be taken as the mass output of a desired product from the crushing. In a GA, a population consisting of M individuals is maintained. All individuals are evaluated and assigned fitness scores, and new individuals are then formed through the procedures of fitness-proportional selection, crossover, and mutation (i.e. small random variations in the network). The process, which is inspired by Darwinian evolution, is repeated until a satisfactory solution to the problem has been found. GAs will not be

described in detail in this paper. For detailed information concerning such algorithms, see e.g. (Holland 1992).

Encoding and Settings

Each chromosome consists of n genes, one gene for each FSM parameter. Each gene consists of 15 binaries (0 or 1). The parameters of the GA can be found in Table 1.

Table 1. Parameters of the GA.

Parameter	Value
Number of individuals	100
Number of generations	500
Probability for mutation of a gene	0.03
Probability for crossover between two individuals	0.3
Mutation type	Bit flip
Selection ranking	Roulette wheel

Fitness

When the FSM parameters are calculated, the plant is simulated with these settings for three operation hours. This corresponds to the time between two CSS adjustments. The fitness for each individual is then taken as cumulated tonnes out of the crushing circuit from the simulation. This fitness function will reward the solution with the highest net outcome.

Case

The plant and equipment

Both the earlier developed algorithm (Hulthén and Evertsson 2008) were tested (Hulthén and Evertsson 2010) and the ground work for the dynamic simulations (Asbjörnsson, Hulthén et al. 2012) was performed at a crushing plant in Uddevalla, 80 km north of Gothenburg. Selecting this plant for this case optimization is good from a reference point of view, but also for future full scale validation.

The crushing plant is owned and operated by NCC Roads. The plant produces high-quality aggregate products ranging in size from 0–2 mm to 16–32 mm in its tertiary crushing stage. The crusher is a Metso Nordberg HP4 equipped with a fine chamber. The feed size to this tertiary crushing stage is 16–70 mm. The crusher is equipped with a system for manual adjustment of the CSS. The cone crusher has been equipped with a Control Techniques Unidrive SP frequency converter, which allowed step less changes of the eccentric speed of the crusher in real-time. The pulleys were configured so that the nominal net frequency, 50 Hz, which then corresponds to 1500 rpm on the motor, would give 952 rpm on the crusher's drive shaft.

After the crusher, a series of two classifying screens sort the product into size fractions of 0–2 mm, 2–5 mm, 5–8 mm, 8–11 mm, 11–16 mm, 16–22 mm and +22 mm. The +22 mm material is always returned

to the crusher in a closed circuit. All products at sizes of 5 mm and larger can be returned in a closed circuit at 0, 50 or 100% re-crushing rates. During the final test runs, 100% of the 8-11 mm product was re-circulated back to the crusher.

An outline of the plant is shown in Figure 2. In total, ten conveyor belts had mass-flow meters monitoring the electrical power draw. The power was measured with power transducers, which can deliver real-time information to a computer, where the actual capacities are calculated.

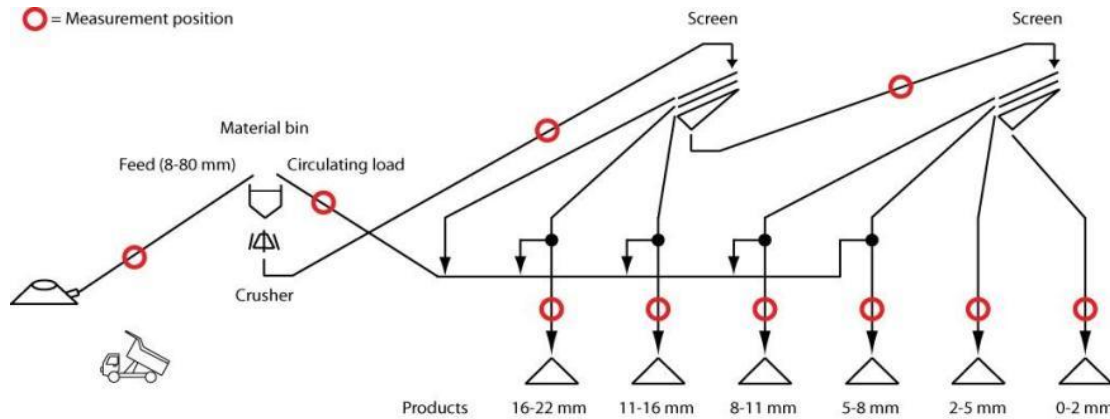

Figure 2. Tertiary crushing stage at NCC Roads' plant in Uddevalla. The plant produces six profitable products from the tertiary stage. The oversize particles are re-circulated to the crusher.

Modelling the Plant

The plant was modeled using the custom build blocks in MATLAB/Simulink and connected in an appropriate way, see Figure 3. Plant model was populated using data from a crushing survey performed at this particular plant. Crushers, screens, and bins were calibrated to represent the process behavior as closely as possible.

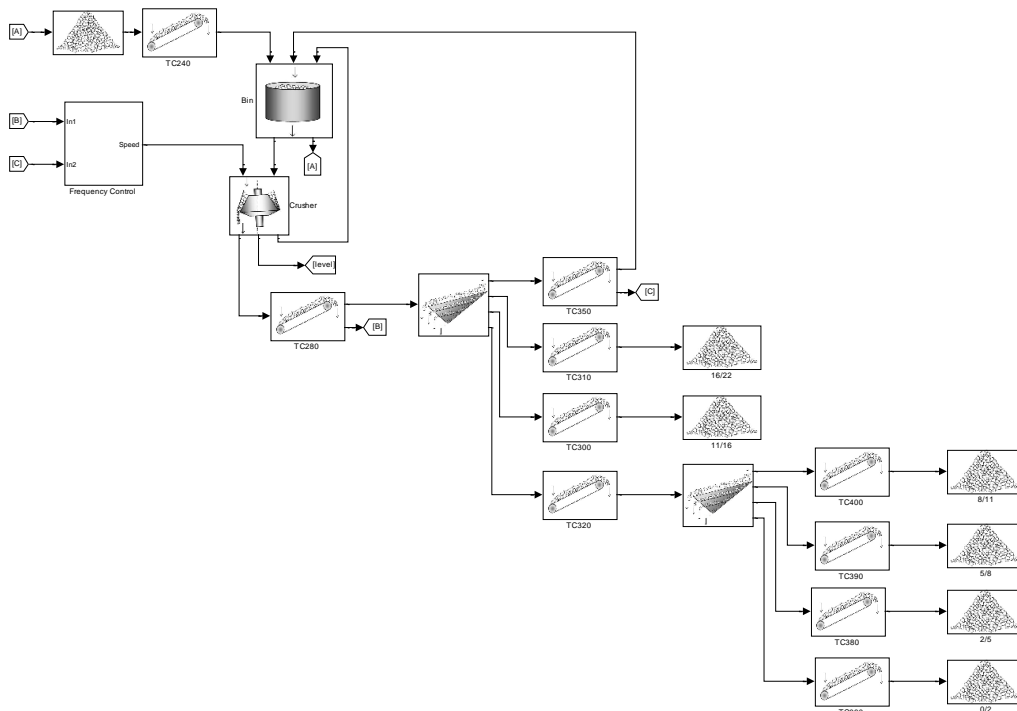

Figure 3. The modelled plant in MATLAB/Simulink. The FSM is in the subsystem located left from the crusher.

The algorithm was implemented in MATLAB together with the dynamic model. The mass flows from the simulated plant could be connected directly into the FSM algorithm. The output from the FSM was the set-point speed which was fed back to the simulated process. Thus a simulator for the algorithm development has been created. The performance of the plant is here defined as the net crushing-stage throughput, i.e. the crusher throughput minus the circulating load, measured in tph.

Results

The first result is that the simulation of the dynamic behaviour in a crushing plant now has been shown capable of simulating a real-time algorithm for crusher parameter selection. The selected speed in one simulation can be seen in Figure 4.

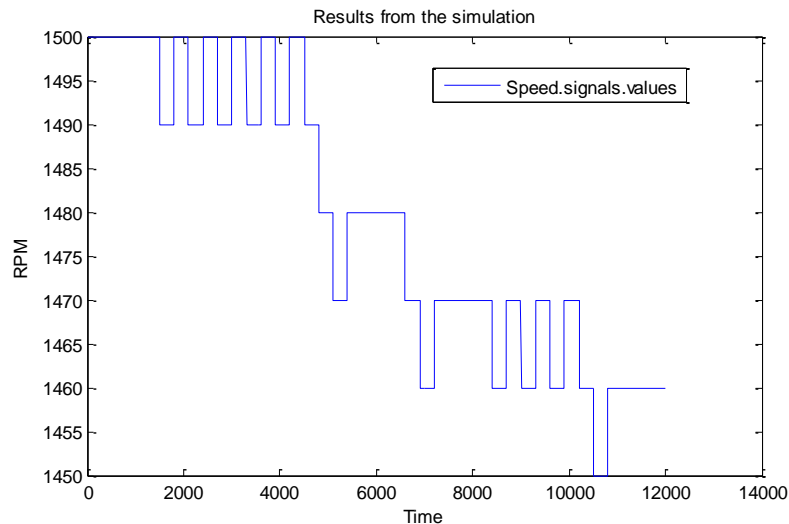

Figure 4. Results from one of the simulations.

The second result, which will be presented at the conference in April, is the values of the optimized parameters and foremost what effect this will have on the simulated plant.

Discussion and conclusions

A simulator for the algorithm development has been created. This simulator can be used when real-time algorithm is to be installed on new crushing plants for the tuning of the parameters. It can also be used if the conditions at a plant have been or will change, in order to see what effect this will have on the optimization algorithm. The expected result is also that this simulator can be used for optimizing the optimization algorithm. If conditions change at a crushing plant, it is important to update the models in the dynamic simulator.

Acknowledgements

This work has been performed within the Sustainable Production Initiative and the Production Area of Advance at Chalmers; this support is gratefully acknowledged.

The authors wish to thank the Development Fund of the Swedish Construction Industry (SBUF), the Swedish Mineral Processing Research Association (MinFo), the Hesselman Foundation for Scientific Research and the Swedish national research program MinBaS (Minerals, Ballast and dimensional Stone) for their financial support.

References

- Asbjörnsson, G., E. Hulthén, et al. (2012). Modelling & Simulation of Dynamic Crushing Plant Behaviour with MATLAB/Simulink. Comminution '12. Cape Town, South Africa.
- Asbjörnsson, G., E. Hulthén, et al. (2012). "Modelling and dynamic simulation of gradual performance deterioration of a crushing circuit – Including time dependence and wear." Minerals Engineering 33: 13-19.
- Holland, J. (1992). Adaptation in natural and artificial systems, MIT Press.
- Hulthén, E. and C. M. Evertsson (2006). A Cost Effective Conveyor Belt Scale. 11th European Symposium on Comminution. Budapest, The Hungarian Chemical Society (MKE).
- Hulthén, E. and C. M. Evertsson (2008). On-line Optimization of Crushing Stage using Speed regulation on Cone Crushers. XXIV International Mineral Processing Congress, Beijing, China.
- Hulthén, E. and C. M. Evertsson (2009). "Algorithm for dynamic cone crusher control." Minerals Engineering 22(3): 296-303.
- Hulthén, E. and C. M. Evertsson (2010). Two Variable Real-Time Algorithm for Cone Crusher Control. XXV International Mineral Processing Congress, Brisbane, Australia.
- Mealy, G. H. (1955). "A Method for Synthesizing Sequential Circuits." Bell System Technical Journal 34: 1045–1079.

AN ON-LINE TRAINING SIMULATOR BUILT ON DYNAMICS
SIMULATIONS OF CRUSHING PLANTS

Asbjörnsson, G., Hulthén, E. and Evertsson, C.M., An On-line Training Simulator Built on Dynamic Simulations of Crushing Plants, Presented at the 15th IFAC symposium on Control, Optimization and Automation in Mining, Mineral and Metal Processing., San Diego, USA, 25-28 August 2013, Published in the conference proceedings.

AN ON-LINE TRAINING SIMULATOR BUILT ON DYNAMIC SIMULATIONS OF CRUSHING PLANTS

G Asbjörnsson*, E. Hulthén** and C.M. Evertsson***

*Chalmers University of Technology, SE-41296 Gothenburg, Sweden. (gauti@chalmers.se)

**Chalmers University of Technology, SE-41296 Gothenburg, Sweden. (erik.hulthen@chalmers.se)

***Chalmers University of Technology, SE-41296 Gothenburg, Sweden. (magnus.evertsson@chalmers.se)

Abstract: Crushing plants are widely used around the world as a pre-processing step in the mineral and mining industries or as standalone processing plants for final products in the aggregates industry. Despite automation and different types of advanced model predictive control, many the processes are still managed by operators. The skill of the operators influences the process performance and thus production yield. Therefore, it is important to train the operators so they know how to behave in different situations and to make them able to operate the process in the best possible way.

Different types of models for crushers and other production units have been developed during the years and the latest improvement is the addition of dynamic behavior which gives the crushing plants a time dependent behavior and performance. This can be used as a simulator for operators training. By connecting an Internet based Human Machine Interface (WebHMI) to a dynamic simulator with the models incorporated, an on-line training environment for operators can be achieved.

In this paper, a dynamic crushing plant simulator implemented in MATLAB/SIMULINK has been connected to a WebHMI. The WebHMI is accessible via the Internet, thus creating a realistic control room for operators' training. In the created training environment, the operators can be trained under realistic conditions. Simple training scenarios and how they could be simulated are discussed. Apart from the increased level of knowledge and experience among the operators, the time aspect is an important factor. While a real crushing plant is still being built, the operators to be can already be trained, saving a lot of the commissioning and ramp up time.

Keywords: Crushing, Cone Crusher, Simulator, Operator, Training, on-line

INTRODUCTION

Crushing plants are widely used around the world as a pre-processing step in the mineral and mining industries and as standalone processing plants in the aggregates industry. In crushing plants as well as in every other process industry, the process relies on operators to make decisions in order to keep the process running smoothly, despite of increased demand on automation and different advanced model predictive control. The operators make these decisions depending on their previous experience and training. In Figure 1 three operators at a real crushing plant, discussing an appropriate response to certain process behavior can be seen.

According to Bainbridge (Bainbridge, 1983) the development in control systems and increase automation leaves the operator in a dilemma. On one hand, the development of the control strategy is left to the system designer, who develops the system to

minimize the need for the operators, while on the other hand the system designer leaves tasks, which he is unable to automate to the operators. The operator is therefore left with specific tasks to manage. Due to this, the operators can lose important knowledge of the process.



Figure 1. Operators interacting with the process via HMI/SCADA.

Operators mostly rely on their knowledge gained from previous experience. Therefore, new operators often

lack the prerequisite knowledge when it comes to critical scenarios. Training of new operators takes time where the new operator is under guidance from a more experienced operator under particular time.

This type of knowledge transfer is highly individual and depends on the more experienced operator's capability in transferring the knowledge. A better way of gaining this necessary knowledge is with a hands-on experience but that is usually not possible or feasible due to risk of disturbing the process or due to high cost. According to Li (Li, McKee *et al*, 2011) the lack of systematic training for operator is a bottleneck when it comes to enhancing the operator's capability in interacting with the control system.

In this paper, a dynamic crushing plant simulator implemented in MATLAB/SIMULINK has been connected to a WebHMI. The WebHMI is accessible via the Internet, thus creating a realistic control room for operators' training. In the created training environment, the operators can be trained under realistic conditions. Simple training scenarios and how they could be simulated are discussed. Apart from the increased level of knowledge and experience among the operators, the time aspect is an important factor. While a real crushing plant is still being built, the operators to be can already be trained, saving a lot of the commissioning and ramp up time.

THEORY

In the authors' earlier work, the focus has been on modeling of single machines, modeling of plants and on real-time optimization. The latter has included automation, HMI and the operators' process interaction, with the purpose to increase plant performance. During the past few years, the authors have been focusing on representing the dynamic effects in a crushing process with the purpose of improving dynamic simulation. These studies include representation of wear in dynamic simulations (Asbjörnsson *et al*, 2012) and development of a bin model for better representing the dynamic consequences which arise in the process and in turn increase the fidelity of the simulations (Asbjörnsson *et al*, 2012). In connection with previous projects, the authors have developed a simulator in MATLAB/Simulink, which is capable of evaluating plant performance. This simulator has been used to explore and validate possible process adjustment to achieve higher production throughput (Asbjörnsson *et al*, 2012).

Already in the early 90s, there were a number of papers discussing the potential benefits of developing

dynamic simulator for the use of operator training (McKee and Napier-Munn, 1990; Napier-Munn and Lynch, 1992). However, due to usual lack of computer power these simulations were too slow to run in real-time.

Studies have been done in the area of minerals processing and in related areas, e.g. chemical and electric processes, which state the benefits of training operators prior to introducing them to the actual system or even supply ongoing training. The benefits may include improved performance in making faster and more appropriate decisions, more effective hands-on experience, cost effective training with no unnecessary production interruption (Shepherd, 1986; Dougall, 1997; Bessiris *et al*, 2011). The operator training setup can also be used to evaluate the human machine interface (HMI) or control system before installation (Dougall, 1997).

SYSTEM STRUCTURE

The system structure used in this study is a development of a previously developed operator room that was design and built at Chalmers University of Technology (Hulthén *et al*, 2012). The system has been changed in order to allow users to connect to the virtual crushing plant vid the Internet. The system is implemented on a central computer which runs the simulated process and communicates the data between the simulated process and the WebHMI with an OPC server, se Figure 2. The data is logged to enable post-processing of the run training scenarios.

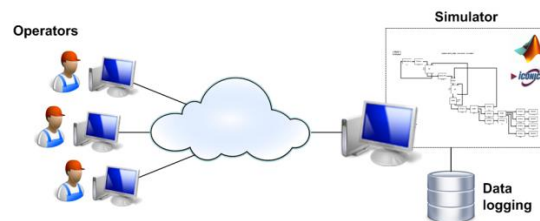

Figure 2. The system structure for the operator training

Simulator in MATLAB/Simulink

Plant dynamics is a complex phenomenon where correlation and casualization can be vague. To simulate plant dynamics mathematical models for every production unit, e.g. crushers, screens, conveyors, silos, etc., has been created. The models describe the changes in flow and particle size of the material traveling through the plant. Arranging and setting up the production line to produce a particular fraction in the simulation should represent the actual

process as the production line can often be affected by upstream and/or downstream factors, due to particular production units.

The simulator used during this study is being developed in MATLAB/Simulink at Chalmers University of Technology. The simulator has previously been used to validate dynamic plant performance at a large mineral plant struggling to keep a stable process (Asbjörnsson *et al*, 2012).

Since each equipment model is an independent entity, the communication between models needs to be standardized. The data flows from one model to another and is transformed as it moves through the plant model. This data contains important information about the material which determines the performance of the system. This includes information about the particle size distribution ($PSD_i(t)$), the mass-flow ($\dot{m}(t)$) and properties of the material ($\gamma_i(t)$) as illustrated in Eq. 1. Each model's output is bundled together into a single vector which is communicated to the next model which in turn extracts the necessary information.

$$Model\ input = \begin{bmatrix} PSD_i(t) \\ \dot{m}(t) \\ \gamma_i(t) \end{bmatrix} \quad (1)$$

One of the fundamental principles of simulating dynamic systems is the conservation of mass. In a dynamic simulation, the constrain for mass-balance is solved with the accumulate of material according to Eq. 2. The mass in the system, $m(t)$, is therefore a result of the mass-flow into the system ($m_{i,in}(t)$), the mass-flow out of the system ($m_{j,out}(t)$) and the mass that was in the system at the start of the simulation ($m(t_0)$).

$$m(t) = \int_{t_0}^t (m_{i,in}(t) - m_{j,out}(t)) dt + m(t_0) \quad (2)$$

The volume and level of material within each equipment is calculated by Eq. 3 where $V(t)$ is the volume occupied by the material, $m(t)$ equals the total mass in the system, ρ_{Bulk} is the density of the bulk material, A is the bottom area of the unit and $y(t)$ is the resulting level of the material.

$$V(t) = \frac{m(t)}{\rho_{Bulk}} \Rightarrow y(t) = \frac{m(t)}{A\rho_{Bulk}} \quad (3)$$

The properties of the material ($\gamma_i(t)$) and particle size distribution ($PSD_i(t)$), are retained within the bulk material with a perfect mix model that is dependent on

the accumulation of material $m(t)$ and the mass-flow into the system ($m_{i,in}(t)$) as illustrated in Eq. 4.

$$\frac{d\gamma_i(t)}{dt} = \frac{m_{i,in}(t)}{m(t)} (\gamma_{i,in}(t) - \gamma_i(t)) \quad (4)$$

The feeders in the system are modelled as a first order system, see Eq. 5. The feeders are equipped with both an ON/OFF control and a proportional–integral–derivative controller (PID controller) which the operator can switch between for more process interaction.

$$G(s) = \frac{Y(s)}{U(s)} = \frac{K_p}{\tau s + 1} \quad (5)$$

Two different conveyors models are utilized in this study. The majority of the conveyors are modeled as constant dead time as illustrated with Eq. 6. One of the conveyors is equipped with a variable speed conveyor model, Eq. 7. This model keeps tracks of the material on the conveyor, allowing the user to manipulate the speed of the conveyor and enable the stopping of the conveyor without deleting material. m is the flow of material which is a function of the speed of the conveyor, the length L , the width w and the number of section (n) the conveyor is divided into.

$$G(s) = \frac{Y(s)}{U(s)} = e^{-\theta s} \quad (6)$$

$$\begin{bmatrix} \dot{x}_1 \\ \dot{x}_2 \\ \vdots \\ \dot{x}_n \end{bmatrix} = \begin{bmatrix} -m & 0 & \dots & 0 & 0 \\ m & -m & \dots & 0 & 0 \\ \vdots & \vdots & \ddots & \vdots & \vdots \\ 0 & 0 & \dots & m & 0 \\ 0 & 0 & \dots & m & -m \end{bmatrix} \begin{bmatrix} x_1 \\ x_2 \\ \vdots \\ x_n \end{bmatrix} + \begin{bmatrix} n / (L \cdot w) \\ 0 \\ \vdots \\ 0 \end{bmatrix} \cdot Q_{in} \quad (7)$$

The crusher model used in this study is a semi-empirical one. The crusher performance is estimated with a fitted Swebrec function which was developed in previous studies (Asbjörnsson *et al*, 2012). In this function (Eq. 8.) the x_{max} represents the top size of the material, i.e. the size of the largest particle, x_{50} the size of the 50 % passing, x defines the size intervals and b defines the shape of the curve. The capacity of the crusher ($\dot{m}_{Capacity}$) is estimated with a simplified version of the mechanical model developed by Evertsson (Evertsson, 2000), See Eq. 9. The radius $R_i(\alpha)$ is the radius from which a particle with speed originates. The bulk density of the aggregate is

denoted ρ . When a free falling particle achieves contact with the mantle, at eccentric angle α_c , the inner radius is R_{i, α_c} .

$$f_i(x) = \left(\frac{\ln\left(\frac{x_{\max}}{x_i}\right)}{\ln\left(\frac{x_{\max}}{x_{50}}\right)} \right)^b \quad (8)$$

$$\dot{m}_{Capacity} = \int_0^{\alpha_c} \int_{R_i(\alpha)}^{R_0} \rho(a)v(a)rdrd\alpha \quad (9)$$

The screen model is a material splitter with a constant delay. The split is determined by the set aperture on the screen, the mass flow and the particle size distribution of the incoming feed. The model, shown in Eq. 10., determines the split of the material mass flow and particle size distribution, where \mathbf{S} is a diagonal matrix with the values determined by the screen aperture and an efficiency curve.

$$m_{i,ut}(t) = \mathbf{S}m_{i,in}(t - \theta) \quad (10)$$

The simulated process used in this study consists of a single crusher, two screens, 10 conveyors and a material source. The process was aimed to represent a secondary or tertiary crushing stage in a medium sized aggregate production which produces 5 different products. The implementation in MATLAB/Simulink can be seen in Figure 3. An overview of the process is more easily seen in Figure 4.

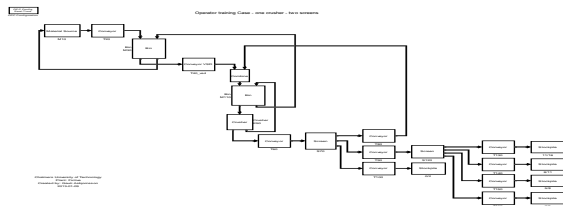

Figure 3. The simulated process in MATLAB/Simulink.

Human-Machine interface

The operators interact with the process usually through HMI/SCADA system from the control room. How the information from the process is visualized is important for the operator, who needs to be able to interpret what the system is trying to communicate. The WebHMI for the operators training simulator is created in Iconics Genesis software. The WebHMI illustrated in Figure 4 was developed for this study. Here the operator can start and stop different units, change from different control on the feeders, change the operating

parameters on the crusher and initiate different malfunctions in the process.

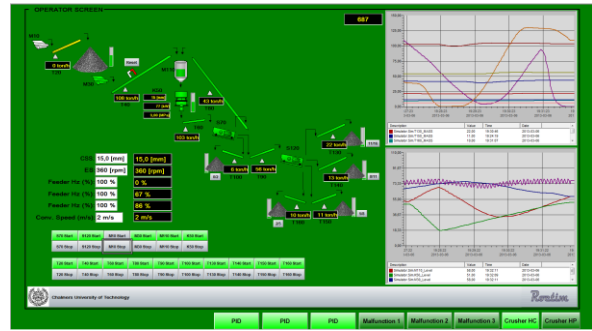

Figure 4. The HMI developed for the configuration using ICONCS to enable the operator to interact with the simulation.

CASE STUDY

A case study was performed for the Swedish aggregate industry (SBMI) as a complementary training in their standard introduction course in aggregate production. The course aims to give newly employed personnel information about different aspects of crushing rocks for aggregate production, e.g. machines, quality, legislation, and the process. There were 22 participants from different companies with different backgrounds, ranging from accounting to actual operators. A photo from the course held in January 2012 can be seen in Figure 5.



Figure 5. Performing one of the scenarios at the course.

As an exercise the course participants were asked to plan their production with regards to preferred product request from a fictive customer. Wear was included on crusher and screens that the participants needed to take into consideration while planning their production. Each calibration caused a predetermined downtime for the production. By working with two different lengths of the down-time, five minutes respectively 10 minutes, the participants could see how this moved the

optimal number of calibrations on a crusher during a week, see Figure 6.

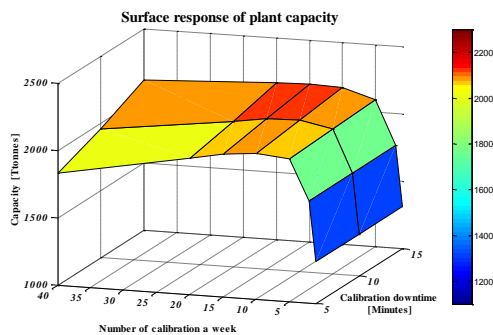

Figure 6. Results from simulation to find the optimum numbers of calibrations during a week's operation.

Additional to the production planning with regards to wear the course participants were asked to identify anomalies in the process as a consequence of malfunction or breakdown in the different production units. Four different event-driven scenarios were created for the course participants to identify potential origin of the problems from information visualized on the WebHMI. The following scenarios were created:

- Scenario 1: Clogging on the screen causing the screen to fill.
- Scenario 2: Magnetic sensors causing the conveyor to stop.
- Scenario 3: Malfunction in one of the conveyors causing an increased power draw.
- Scenario 4: Overfilling the crusher causing material spill

In the first two scenarios, scenario 1 and 2, the process would eventually stop after initiating the breakdown, while for scenario 3 and 4 the production continued. In scenarios 1 and 3 the process was slowly affected and if aware of the process the potential operators could identify the anomalies in the process before it causes considerable damage. The course participants were able to identify the changes in the process after relatively short time, since it was the focus of the exercise. A discussion about the cause and the origin of the problems was conducted with the participants to get them involved in process of solving the simulated breakdown.

CONCLUSION

In this paper the fundamental base for an online operator training has been presented. With this system structure operators or people involved in the process, such as it was during the case study, are able to interact with the process without risking disturbing the actual process.

In this environment different configuration setup can be available for operators to better prepare them for infrequent events, such as conveyor malfunction or for planning the operation better to faster respond to changes in incoming customer request.

As mentioned in the introduction, performing operator training can increase operators' capability in reacting to changes in the process faster and in a more appropriate way. With operator, training simulator the operator is able to interact with the process without risking any potential damage to the actual equipment, giving the operator a valuable hands-on experience.

The possibilities for improvement in this very early stage of web-based operator training in the aggregate and mining industry are enormous. Introducing hidden faults, letting the participants practice in their home plant configuration and the ever on-going model improvements being some of them.

ACKNOWLEDGEMENT

This work has been performed within the Sustainable Production Initiative and the Production Area of Advance at Chalmers; this support is gratefully acknowledged.

The authors wish to thank the Hesselman Foundation for Scientific Research and the Swedish national research program MinBaS (Minerals, Ballast, and dimensional Stone) for its financial support.

Special Thanks to Christian Ankarbranth and Martin Mårtensson at Chalmers university of Technology for doing the ground work in connecting the dynamic simulator to the HMI and PLC to enable to operator training.

REFERENCES

- Asbjörnsson, G., Hulthén, E., Evertsson, C.M. (2012). "Modeling and dynamic simulation of gradual performance deterioration of a crushing circuit – Including time dependence and wear." *Minerals Engineering* (33) pp 13-19.
- Asbjörnsson, G., Hulthén, E., Evertsson, C.M. (2012). "Modeling and simulation of dynamic crushing behavior." in review.
- Asbjörnsson, G., Hulthén, E., Evertsson, C.M. (2012). Modeling Dynamic Behavior of Storage Bins for Material Handling in Dynamic simulations. IMPC. New Delhi.
- Bainbridge, L. (1983). "Ironies of automation." *Automatica* 19(6): 775-779.
- Bessiris, Y., D. Kyriakopoulou, et al (2011). Long Distance Operator Training. Computer Aided Chemical Engineering. M. C. G. E.N. Pistikopoulos and A. C. Kokossis, Elsevier. Volume 29: 1115-1119.
- Dougall, D. J. (1997). "Applications and benefits of real-time IO simulation for PLC and PC control systems." *ISA Transactions* 36(4): 305-311.
- Evertsson, C.M., Cone Crusher Performance, in Department of Machine and Vehicle Systems. 2000, PhD thesis from Chalmers University of Technology: Gothenburg.
- Hulthén, E., Asbjörnsson, G., Evertsson, C.M. (2012). A Training Simulator for Crushing Plant Operators. IMPC. New Delhi
- Li, X., D. J. McKee, et al. (2011). "The control room operator: The forgotten element in mineral process control." *Minerals Engineering* 24(8): 894-902.
- McKee, D. J. and T. J. Napier-Munn (1990). "The status of comminution simulation in Australia." *Minerals Engineering* 3(1-2): 7-21.
- Napier-Munn, T. J. and A. J. Lynch (1992). "The modeling and computer simulation of mineral treatment processes -- current status and future trends." *Minerals Engineering* 5(2): 143-167.
- Shepherd, A. (1986). "Issues in the training of process operators." *International Journal of Industrial Ergonomics* 1(1): 49-64.

IMPLEMENTATION OF DYNAMIC SIMULATION AT ANGLO PLATINUM

Asbjörnsson, G., Muller, D., Hulthén, E. and Evertsson, C. M., Implementation of Dynamic Simulation at Anglo Platinum, Presented at the 9th International Comminution Symposium, Cape Town, South Africa, 17-20 April 2014, Published in the conference proceedings.

Implementation of Dynamic Simulation at Anglo Platinum

Gauti Asbjörnsson, M.Sc. , Erik Hulthén, Ph.D. & Magnus Evertsson, Ph.D.
Chalmers Rock Processing Research, Chalmers University of Technology, Gothenburg, Sweden.
Corresponding author: gauti@chalmers.se

*D Muller**
Lead Process Control Engineer, Anglo Platinum, Control and Instrumentation Department, Johannesburg,
South Africa
**Second corresponding author: mullerd@angloplat.com*

Abstract

The dynamics of process operation can be overlooked in design; often with considerable loss of throughput resulting from dynamic fluctuation and mismatch of units across a circuit. As a consequence, higher demand is on design of different control strategies. Designing a circuit with consideration of the implications an operation and control strategies have on the process is essential.

The aim of this paper is to describe the modelling work done for this application and give an overview of the implementation of dynamic simulation platform at Anglo Platinum to support future debugging and tuning of the Advanced Process Control for a planned expansion. This paper builds on previous dynamic modelling work done at the Mogalakwena North Concentrator. The work is focused on system identification and the implementation of the Advanced Process Control algorithm in the dynamic plant model. The dynamic model of the plant was connected to the Advanced Process Control system and the response of the model validated against the behaviour of the plant.

1. Introduction

Crushing plant's design rely on accurate plant simulations. Crushing plants are designed to be able to produce certain throughput on predefined specification (i.e. a certain particle size distribution) while operating at a reasonable cost and at efficient energy consumption.

The dynamics of process operation can be overlooked in design; often with considerable loss of throughput resulting from dynamic fluctuation and mismatch of units across a circuit. As a consequence, higher demand is on design of different control strategies. Designing a circuit with consideration of the implications an operation and control strategies have on the process is essential.

The aim of this paper is to describe the modelling work done for this application and give an overview of the implementation of dynamic simulation platform at Anglo Platinum to support future debugging and tuning of the Advanced Process Control (APC) for a planned expansion. This paper builds on previous dynamic modelling work done at the Mogalakwena North Concentrator (MNC), see Figure 1. The work is focused on system identification and the implementation of the APC algorithm in the dynamic plant model. The dynamic model of the plant was connected to the control system via Object linking and embedding for Process Control (OPC) and the response of the model validated against the behaviour of the plant

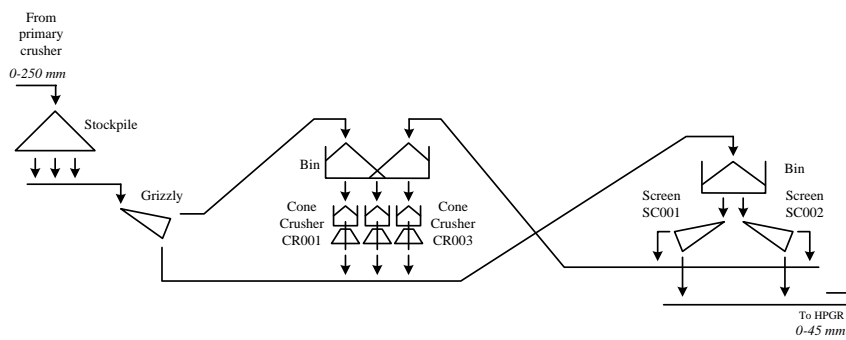

Figure 1. Overview of the circuit at MNC.

2. Modelling

Crushing plants like any other production process are affected by changes over time. To be able to predict the dynamic behavior of any system an understanding about the entities and interaction there in between is essential. System complexity is depending on the level of detail. Simple models are single input single output but that is seldom the case in reality, actual systems are often complex with multiple input, where an output (x) is a function (f) of multiple input variables (u_1, \dots, u_n) and internal variables (x_1, \dots, x_n) which are time dependent (t) [1] (Eq. 1).

$$\frac{dx}{dt} = f(x_1(t), \dots, x_n(t), u_1(t), \dots, u_n(t)) \quad (1)$$

FIFO bin model

In a previous work by Asbjörnsson et al.[2] the basis for the modeling is described. In this paper the focus is on the model development since the original work. One of the critical factors for the performance of the circuit is the material handling. In Asbjörnsson et al. [3] a bin model was proposed to represent the uneven mass accumulation $y_i(t)$ in the crusher bin located in the middle of Figure 1,

which takes into account segregation, angle of repose, the geometry of the bin (length l , width w , segments n and height h) and the volumetric flow rate (Q) at different location, see Figure 2 and Eq. 2.

$$\frac{dy_i(t)}{dt} = \frac{n}{wl} (Q_{in}(t) + Q_{in,Left}(t) + Q_{in,Right}(t) - Q_{out}(t) - Q_{out,Left}(t) - Q_{out,Right}(t)) \quad (2)$$

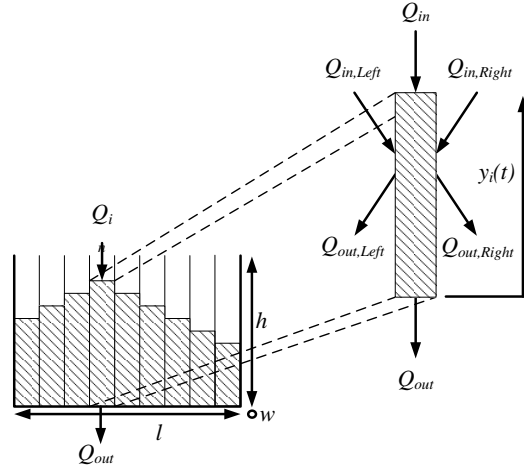

Figure 2. Bin model for the crusher bin.

For the second bin the material properties ($\gamma_i(t)$) were estimated with a perfect mix model (Eq. 3), taking into consideration mass flow rate in ($\dot{m}_{i,in}(t)$), accumulated material ($m(t)$), and the actual value of the material properties coming in ($\gamma_{i,in}(t)$) to the bin.

$$\frac{d\gamma_i(t)}{dt} = \frac{\dot{m}_{i,in}(t)}{m(t)} (\gamma_{i,in}(t) - \gamma_i(t)) \quad (3)$$

To better represent the rapid change in material properties due to operating condition a First-In-First-Out (FIFO) model with a set number of discrete vertical layers was developed for the screen bin, see Figure 3. The model assumes perfect mix within each layer. The model works as a queue for the material that is travelling through the bin which depends on the time step, bin geometry (length, width, and height) number of layers (n) and flow rates (\dot{m}_1 , \dot{m}_2 and \dot{m}_{out}).

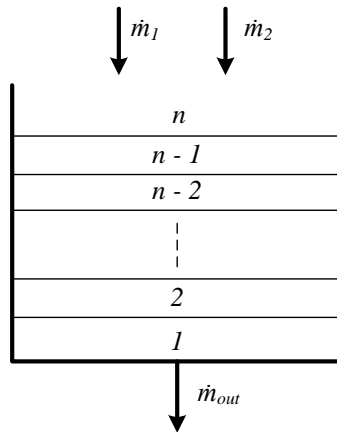

Figure 3. Representation of the FIFO bin model.

Conveyor model

Since the control system adjusts the process with respect to the current on different conveyors a power draw model was implemented, Figure 4. The model is based on the mass-flow meter equation proposed by Hulthén and Evertsson [4]. In their work the purpose was to estimate the mass-flow from the power draw by calculating the material potential energy, moment and the efficiency of the different machine components, Eq. 4.

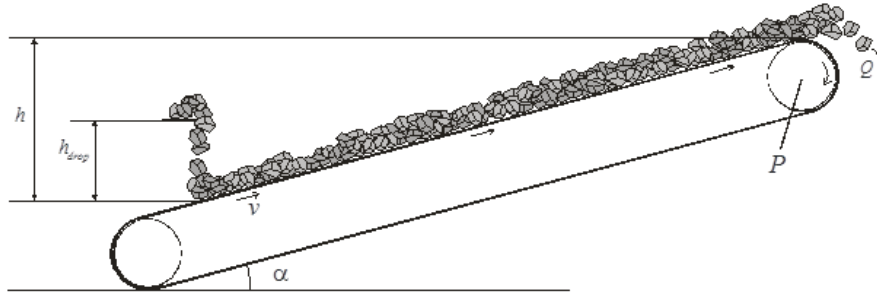

Figure 4. The principles of a conveyor lifting the material a height h .

$$\dot{m} = \frac{P_{load} \eta_{tot}}{gh + v^2 + v\sqrt{2gh_{drop}} \sin(\alpha)} \quad (4)$$

Where P_{load} is the load dependant electrical power, η_{tot} is the total efficiency of the machine components, g is the gravitational constant, h is the height difference of the conveyor, h_{drop} is the height of the material being drop onto the conveyor, v is the speed and α is the angle of the conveyor inclination. By rearranging the equation proposed by Hulthén and Evertsson, the power draw can be estimated for a given mass flow \dot{m} instead. The idling power of the conveyors was estimated using the empirical data collected on site.

The current for a three-phase system can be expressed by Eq. 5. Where I_{load} is the load dependant electrical current, U is the line-to-line voltage and $\cos(\varphi)$ is the power factor.

$$I_{load} = \frac{P_{load} + P_{idle}}{\sqrt{3}U \cos(\varphi)} \quad (5)$$

System Identification

Dynamic modeling is often represented with Figure 5, where the system is described with a set of differential and algebraic equation [5]. How the system react to impulses and step change is essential for the representation of the process. In Figure 6 an alternative representation of the dynamic modelling by taking a Laplace transform of the differential equation in the system.

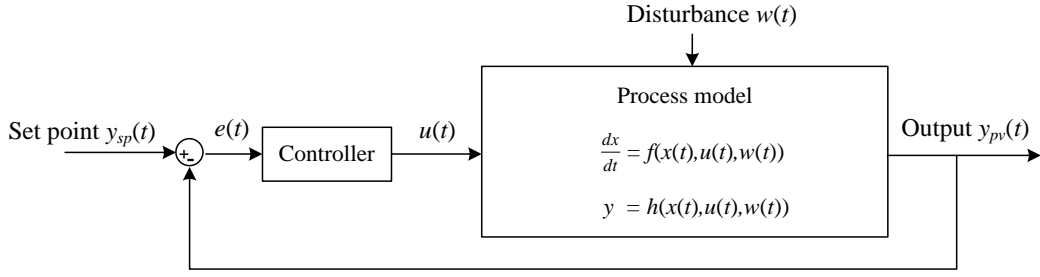

Figure 5. A principle overview of a dynamic system loop.

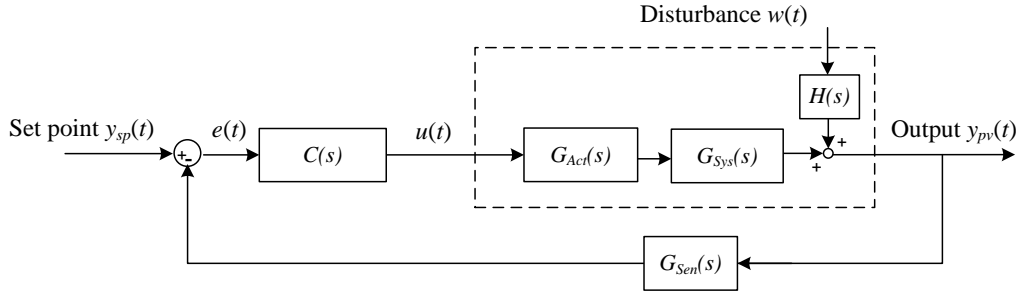

Figure 6. A principle overview of the dynamic modelling as block diagram.

Continuous-time transfer functions ($G_i(s)$ in Figure 6 and Eq. 6) were implemented in the feeder models to model feeder response to change in operation (Eq. 6) in Asbjörnsson et al [2].

$$G(s) = \frac{Y(s)}{U(s)} = \frac{1}{Ts + 1} \quad (6)$$

Where $U(s)$ is the Laplace transform of the input, $Y(s)$ is the Laplace transform of the output (as shown in Eq. 7), T is the time constant and s is the Laplace variable.

$$\begin{aligned} U(s) &= L\{u(t); t \rightarrow s\} \\ Y(s) &= L\{y(t); t \rightarrow s\} \end{aligned} \quad (7)$$

In this work system identification has been used to identify the response of the actuators used to control the mass-flow from the feeders. System identification constructs mathematical models of dynamic systems from measured input-output data and can be used on both linear and nonlinear systems [6]. The system identification is used to determine the relationship, given by for example Eq. 6.

The Laplace transform function $G(s)$ from an input $U(s)$ to an output $Y(s)$ is calculated by continuously minimizing the error between the measured output $y(t)$ and the modelled output $\hat{y}(t)$ by altering parameter ϕ over a time interval $1 \leq t \leq n$. The value ϕ that minimizes Eq. 8. is denoted with $\hat{\phi}_n$ [7].

$$\hat{\phi}_n = \arg \min_{\theta} \frac{1}{n} \sum_{t=1}^n (y(t) - \hat{y}(t | \phi))^2 \quad (9)$$

3. Advanced Process Controller

The primary objective of the crushing plant is the effective utilization of energy in reducing either the top size (typical for secondary crushing plants) or the fraction of critically sized material (typical for in-circuit crushing plants) in order to optimize and balance the overall comminution capability between the crushing and grinding circuit operations. Sustainable control of yield and quality of crusher product requires the use of automated control strategies [8]. Anglo American Platinum's (Amplats) crusher circuit control strategy employs a layered approach that includes both basic control (interlocks, sequences and regulatory control) and supervisory control, consisting of fuzzy logic, rule-based and model predictive control (MPC). This layered approach to the control schema provides a robust and holistic approach to optimization.

Each layer of the control schema contributes in a unique manner to the overall control performance, each having its own associated benefits. The control schema is made up of hierarchical control layers and the effective functioning of each layer is dependent on the performance of the layer feeding into it.

The basic layer of the control schema is implemented within a programmable logic controller (PLC) using interlocks, sequences and feedback control loops (PID algorithms). The primary objective of the basic control layer is to ensure safe operation with appropriate equipment protection, while also stabilizing important process variables such as the fresh feed rate and storage bin levels. The basic control layer handles process upset conditions, equipment failures and implements operator actions. This control layer is a pre-requisite for the advanced process control (APC) layer.

Implementing control on a crushing circuit such as that depicted in Figure 1, using a basic control schema that primarily consists of feedback type controllers, often results in several difficulties which manifest because of the limitations of the control schema to deal effectively with the interactions between the processing units. These limitations include the following:

- Stand alone control of a specific process unit to a fixed setpoint (SP), usually set by the process operator, with
- little or no feed-forward control inputs from its upstream or downstream process units which minimizes the potential to cater for possible constraints in these units.
- Due to the time horizon typically considered by the basic control layer, it is difficult to predict constraints that can develop over longer time periods, and across the various process units where multiple interactions may exist.
- In addition, unmeasured disturbances such as changes in the ore feed size distribution and/or ore hardness, can have a significant impact on the performance and ability of the basic control schema to handle and reject process disturbances resulting from these changing characteristics.

Given the limitations listed above, it is evident that a more advanced control strategy is better suited to optimize the crushing circuit.

Amplats has a well developed supervisory control layer (APC layer) that is tightly integrated into the basic control schema. By combining best-of-breed features from various technologies, Amplats has developed an integrated suite of APC tools that provides engineers with the ability to design, deploy and support an ever growing APC footprint. The suite is centered on a G2 based Expert System and is known as the Anglo Platinum Expert Toolkit (APET). The supervisory control layer (APC layer) consists of a fuzzy logic, rule-based expert system with both model based and model predictive control (MPC)

capability for optimization. The fuzzy logic and rules provides for a robust and non-linear control algorithm to be implemented, which delivers improved stability by de-coupling potentially highly non-linear and interactive process variables.

For the crushing circuit under consideration, optimization was implemented using QPrime, an MPC platform developed by Randburg Control Solutions (RCS), a South African company. By design, the APET platform integrates easily with almost any 3rd party control software, which allows Amplats to evaluate and select appropriate control technology from various suppliers in the industry to achieve the goal of optimal plant performance.

Various process states are derived, prioritized and used to influence the controller action to best deal with the prevailing process upset condition/state. Depending on the active process state, the frequency and/or magnitude of the control actions are adjusted, or an alternative control algorithm (MPC) is implemented.

The APC layer also implements an operational objective in the form of a set process recipe. The most basic form of process recipe setting is achieved by setting ranges (process limits) for the critical CVs and MVs used by the APC. In addition to the set recipe, state control is also included within the supervisory control layer. When calculating the required SP values for the various manipulated variables (these MV's are typically the PID controller SP values), the supervisory control layer takes into account the different process states, as well as the set process recipe - this allows the controller to drive process stability and optimization at the same time.

Several APC controllers were deployed in the crushing circuit's supervisory layer in order to achieve the set objectives. One of these APC controllers targeted stabilization of the secondary screen feed bin levels. Acceptable level stability in these bins could not be achieved with conventional feedback control algorithms (PID) in the basic control layer. After APC implementation, the bin levels were kept within an optimum range, while taking constraints (such as screen and conveyor belt overloading) into account. A significant stability and throughput benefit was achieved with APC alone in the form of increased equipment run time (bin feeders and conveyors) through the elimination of high and low bin level interlock control activating when the bin levels reached extremes.

In order to drive maximum throughput, a "push-pull" control philosophy was introduced within the supervisory control layer. The "push" effect is achieved by introducing as much fresh feed into the circuit as the process states and limits allow by controlling the feed to the circuit. The "pull" effect is achieved by controlling the various feeder speeds withdrawing material out of the screen bins within the circuit, again subject to the process states and limits imposed by the equipment. This is achieved by using the the weigtometer on the crusher discharge conveyor belt as both a MV and a CV. Using the discharge weight as an intermediate variable (both a CV and MV) enables accurate discharge weight control and as a result the disturbances affecting the screen bin level are minimised, and improved screen bin level control is achieved. An overview of the model predictive control paramenters are shown in Figure 7.

It is important to implement an appropriate process "recipe" on both the crusher feed bin and secondary screen feed bin by setting appropriate high and low bin level limits (CVs used by the APC). These bin levels must be maintained and balanced within an optimum range and this is critical to the operation of this circuit. Upstream equipment will be automatically stopped (interlock control in the basic control layer)should the bin levels reach extreme high or low values to prevent overflowing from the bin and equipment damage from ore impacting directly onto the feeders respectively.

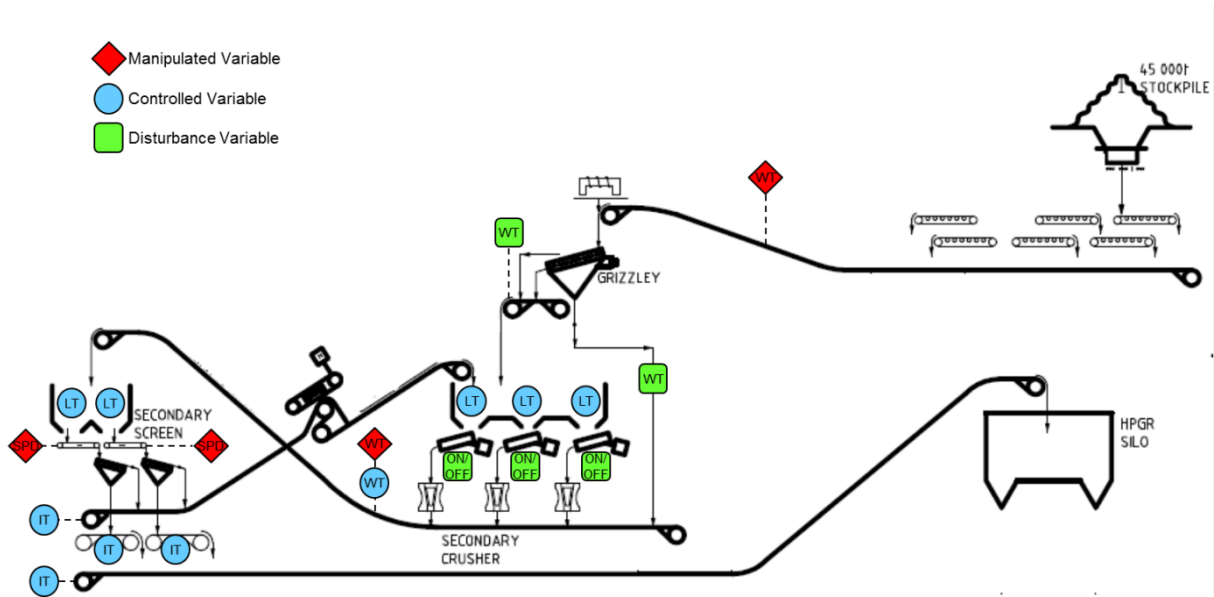

Figure 7. An overview of the model predictive control parameters.

The supervisory control layer includes model based and model predictive control capability for optimization purposes. The MPC calculates the various set point values for many of the basic control layer PID controllers, and sets limits for some of the fuzzy logic rule-based controllers based on the economic objective function. The objective function is geared to maximize the production of crushed material, while at the same time ensuring that the various bin levels, mechanical, process, and safety constraints are not exceeded.

Examples of these constraints are:

- Physical constraints on bin levels (not overflowing nor running empty),
- Conveyor capacity constraints (volume fill and/or installed motor power constraints),
- Screening capacity constraints (e.g. remaining within the installed motor power limit),
- Equipment duty cycles (e.g. limiting the number of starts per period to prolong service life)

Significant process and transport (conveyor) lags exacerbate the effect of process disturbances on the overall circuit stability. Together with the recycle stream, these result in a highly dynamic and non-linear response to disturbances, which is further complicated by the equipment constraints. The MPC algorithm is capable of dealing with the complexity resulting from the modest residence times in the crusher and screen bins, the process lags, the transport lags (stemming from long conveyor runs), and the variability introduced by feed fragmentation, ore characteristics and internal recycle. This would not be possible using only basic PLC layer control.

4. Results

System identification

System identification was performed on the stockpile and screen feeders the in section 405, the crushing section shown in Figure 1. The simplified model structure is shown in Figure 8.

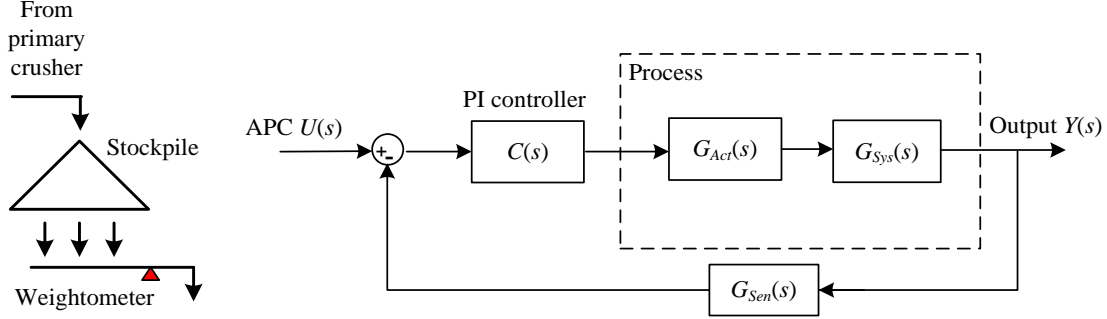

Figure 8. The configuration of the stockpile control loop.

Stochastic disturbances ($w(t)$ in Figure 6) were identified in the measured signal as a random noise with expected zero mean value and with a variance λ , creating an error, $e(t)$, described by Eq. 10. Since the $C(s)$ is the configuration of the controller which in this case is a PID controller the controller's transfer function is known and given by Eq. 11. Values were extracted from the process configuration data.

$$e(t) \in N(0, \lambda) \quad (10)$$

$$C(s) = K_p + \frac{K_i}{s} + K_d s \quad (11)$$

The overall model from Figure 8, without the disturbance, can be simplified to Eq. 12:

$$\frac{Y(s)}{U(s)} = \frac{C(s)G_{Acr}(s)G_{Sys}(s)}{1 + C(s)G_{Acr}(s)G_{Sys}(s)G_{Sen}(s)} \quad (12)$$

For the purpose of this project there was made no distinction between the effects from different components, i.e. the actuator ($G_{Acr}(s)$) and the system itself ($G_{Sys}(s)$). The response of the sensor ($G_{Sen}(s)$) is presumed to be faster than the frequency in the logged data (0.1 Hz) and will therefore be excluded as well since it can not be measured. The response of the process model has therefore been simplified to Eq. 6.

Under the stockpile there are 4 feeders that run one at the time. They are placed in a series along the conveyor and therefore creating a varying distance between the feeder and the weightometer. Multiple sets of data were collected for the model estimation and validation. The data was collected from different stockpile feeders to see if there was any difference lag and dead-time. Six different linear models were estimated to be able to represent the system dynamics. These are first, second and third order response models with dead time θ , lag-time τ_i , and with and without zeros τ_i , Eq. 13 - Eq. 18.

$$G(s) = \frac{Y(s)}{U(s)} = \frac{K_p}{1 + \tau_1 s} e^{-\theta s} \quad (13)$$

$$G(s) = \frac{Y(s)}{U(s)} = \frac{K_p}{(1 + \tau_1 s)(1 + \tau_2 s)} e^{-\theta s} \quad (14)$$

$$G(s) = \frac{Y(s)}{U(s)} = \frac{K_p}{(1 + \tau_1 s)(1 + \tau_2 s)(1 + \tau_3 s)} e^{-\theta s} \quad (15)$$

$$G(s) = \frac{Y(s)}{U(s)} = \frac{K_p(1 - \tau_z s)}{1 + \tau_1 s} e^{-\theta s} \quad (16)$$

$$G(s) = \frac{Y(s)}{U(s)} = \frac{K_p(1 - \tau_z s)}{(1 + \tau_1 s)(1 + \tau_2 s)} e^{-\theta s} \quad (17)$$

$$G(s) = \frac{Y(s)}{U(s)} = \frac{K_p(1 - \tau_z s)}{(1 + \tau_1 s)(1 + \tau_2 s)(1 + \tau_3 s)} e^{-\theta s} \quad (18)$$

Each of the models was run in system identification toolbox in Matlab[®] together with the controller transfer function, to obtain appropriate model parameter. The model outputs followed the measured output closely, capture the main system dynamics. Linear model is therefore sufficient in representing the dynamics of the system. The results from a calculation period and a corresponding validation period can be seen in Figure 9 and in Table 1.

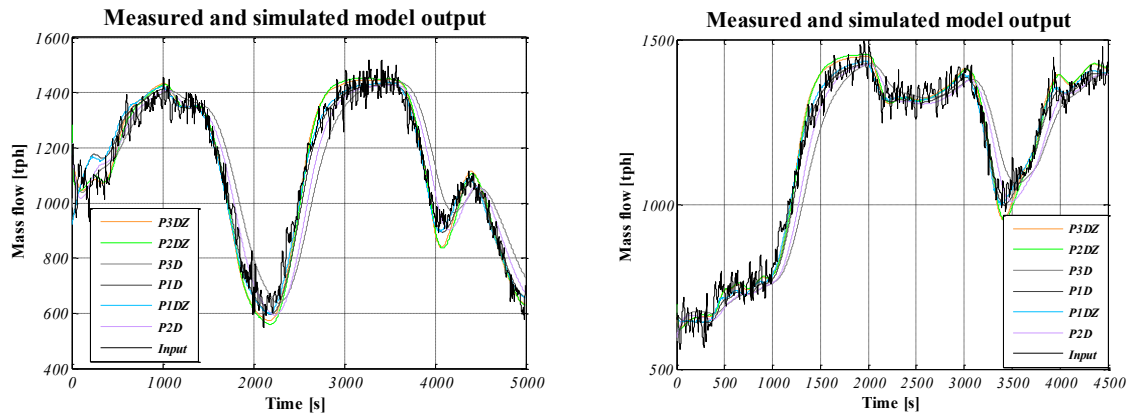

Figure 9. Measured and modelled response of the stockpile feeder for model fitting period and validation period.

In this case the best fit was for the first order model with zero in both cases with best fit of 80.46 resp. 88.54. The first order model with zero is there most suited for the modelling work. Visual results of the step response for the stockpile feeders are shown in Figure 10-12 and the error between the measured response and the simulated response in Table 1.

Table 1. Simulation results for best fit

Response model	Best fit: Empirical data	Best fit: Validation
1 st order with zero	80.46	88.54
2 nd order with zero	77.53	84.04
3 rd order, with zero	78.96	84.70
1 st order	79.63	86.91
2 nd order	70.78	78.86
3 rd order	58.76	72.57

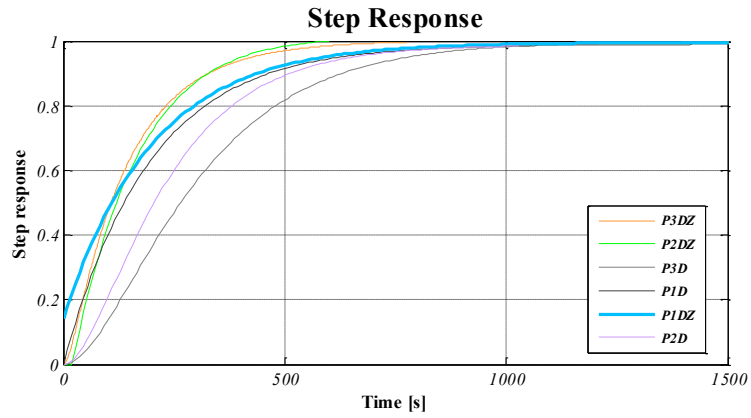

Figure 10. The step response of the different functions. The best results were obtained with a first order transfer function with a zero (marked with a tick blue line).

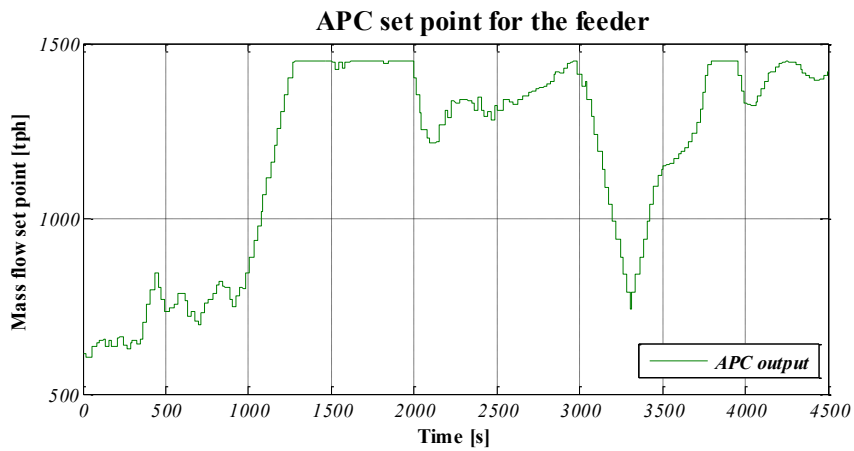

Figure 11. The APC set point for the feeder.

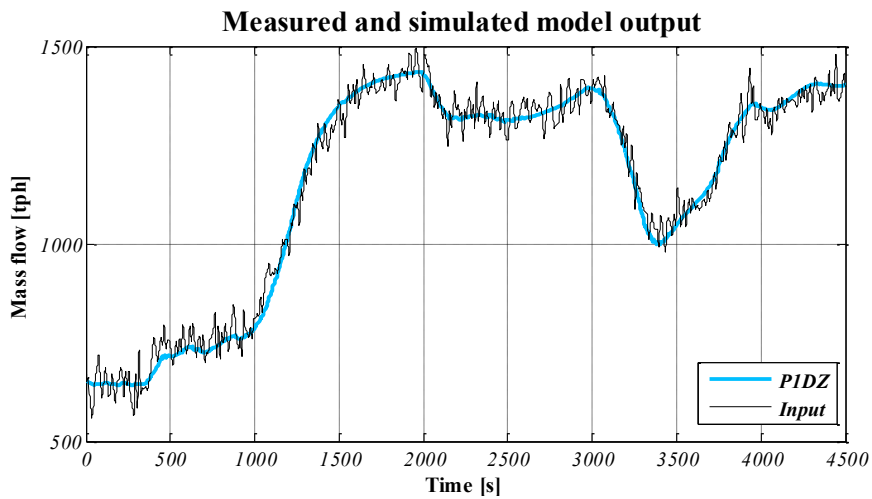

Figure 12. The measured and simulated response of the feeder with a first order response model with zero.

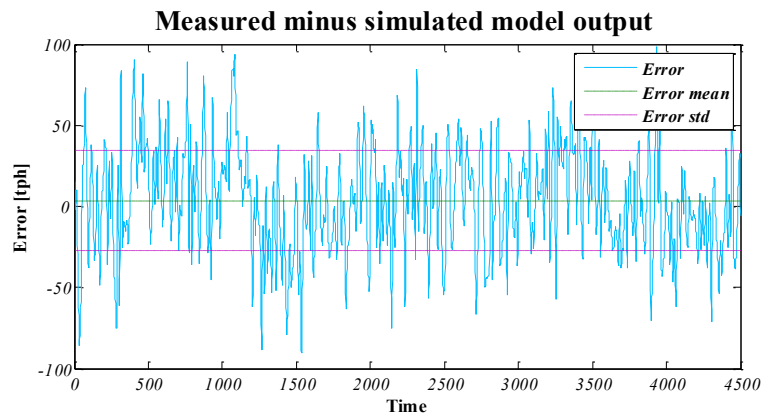

Figure 13. The error between the measured output and the simulated output, with the mean error and the standard deviation calculated.

Implementation

The implementation was conducted at Anglo Platinum. The implementation is a part of performance testing of the simulation platform to verify system performance characteristics. The objective was to perform a visual verification of the start-up sequences of the plant and simulate different operating conditions with the same APC as the actual process.

The proposed system structure for the performance testing is illustrated in Figure 14. The MNC plant model was designed to represent the 405 section of the plant which is control by the APC. The APC acts as supervisory controller, consisting of fuzzy logic, rule-based and model predictive control (MPC) as described earlier. The APC calculates the required SP values for the various manipulated variables (typically the PID controller SP values), taking into account the different process states, as well as the set process recipe.

The APC supplies therefore set points for the regulatory PID controllers in the circuit. The regulatory PID controllers were implemented in the simulation model. The data from the simulation was transferred to the APC via OPC tags in the model and logged.

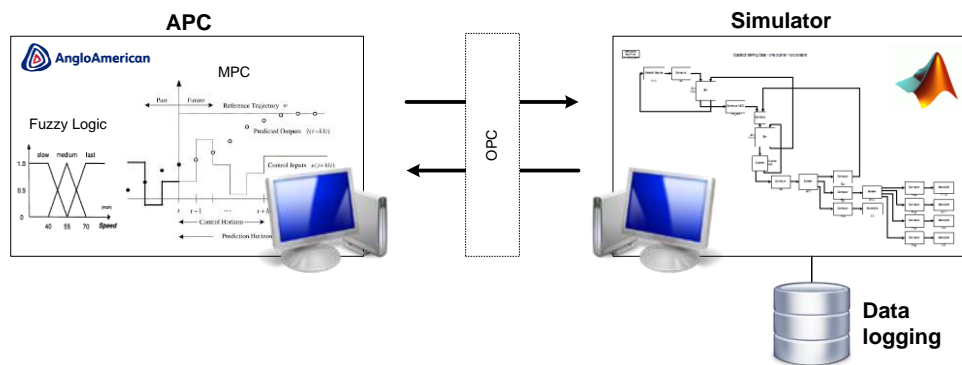

Figure 14. System structure for the implementation.

The step-time of the simulation was synchronized to the control system and ran at 10 times real-time for enabling observation while the simulations were running. An in-house developed HMI was used to observe the process during simulations.

The process simulation was run for 8 hours while under the simulation period no external disturbances were included. Between each simulation the simulation conditions were changed slightly to assess the respond of each run, visual validations were performed with an experienced control engineer from Anglo American’s Process Control and Instrumentation Department. Figure 15 illustrates the change in mass flow into the circuit section 405 (a), The mass flow on conveyor 405CV001 after the crushers (b), The mass flow for the circulating load on conveyor 405CV003 (c) and mass flow on conveyor 405CV006 out from the circuit section 405 (d), during one of these simulated cases. For this period the plant average performance was on average at 1455 tph while the set point for the plant was at 1500 tph.

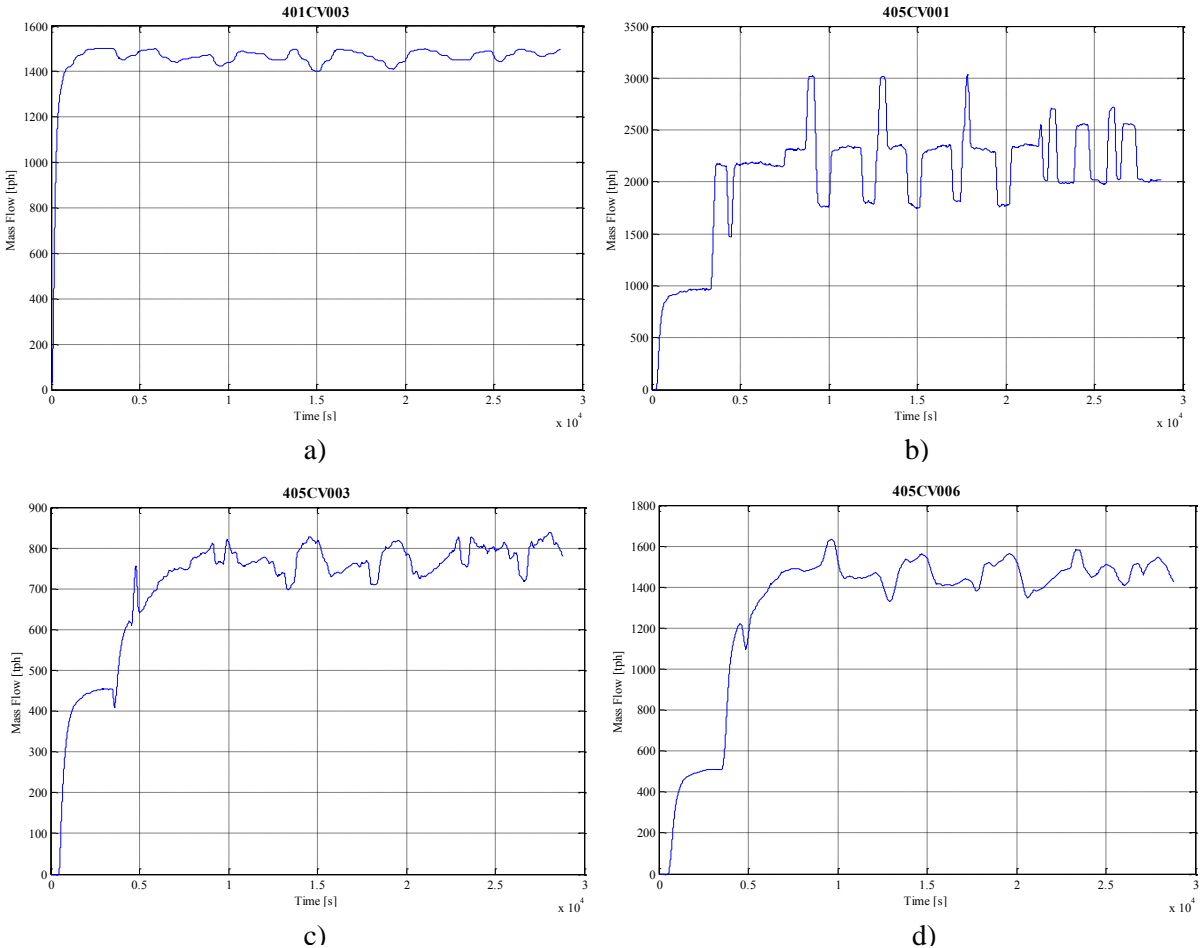

Figure 15. Data from the process simulation, mass flow into the circuit section 405 (a), The mass flow on conveyor 405CV001 after the crushers (b), The mass flow for the circulating load on conveyor 405CV003 (c) and mass flow on conveyor 405CV006 out from the circuit section 405 (d).

5. Conclusion

In this paper the foundation for an engineer support tool that can be used while designing and tuning the plant controller for a planned expansion has been illustrated

Running process simulation prior to commission of production processes is generally considered to increase reliability of the process and speed up the ramp-up time needed to reach predicted plant performance. The modelled plant respondent accurately to the implemented APC, according to visual comparison with the actual process. Connecting the plant model to the control system is although a time consuming and repetitive task for engineers.

System Identification provides a fast estimation of the possible response models for feeders. For the stockpile feeders the System Identification gave a highly accurate responds model by utilizing a first order responds model with zero. The reliability of the response model depends on the sampled period: for the screen feeders the data was questionable due to the configuration circuit, measured points and constantly changing conditions.

6. Acknowledgement

This work has been performed within the Sustainable Production Initiative and the Production Area of Advance at Chalmers; this support is gratefully acknowledged.

The authors wish to thank the Hesselman Foundation for Scientific Research and the Swedish national research program MinBaS (Minerals, Ballast and dimensional Stone) for its financial support.

Anglo Platinum and their personnel at Mogalakwena and at the Control and instrumentation department in Johannesburg are gratefully acknowledged for all of their support and efforts to make this work possible

7. Reference

1. Ljung, L. and T. Glad, eds. *Modelling of Dynamic Systems*. Prentice Hall Information and System Sciences, ed. T. Kailath2002, Prentice Hall Inc.
2. Asbjörnsson, G., E. Hulthén, and M. Evertsson, *Modelling and simulation of dynamic crushing plant behavior with MATLAB/Simulink*. Minerals Engineering, 2013. **43–44**(0): p. 112-120.
3. Asbjörnsson, G., E. Hulthén, and M. Evertsson, *Modelling Dynamic Behaviour of Storage Bins for Material Handling in Dynamic simulations*, in *XXVI International Mineral Processing Congress (IMPC)2012*: New Delhi, India.
4. Hulthén, E. and M. Evertsson. *A Cost Effective Conveyor Belt Scale*. in *11th European Symposium on Comminution*. 2006. Budapest, Hungary.
5. Marlin, T.E., *Process Control - Designing Processes and Control Systems for Dynamic Performance*. 2nd ed2000: McGraw-Hill Chemical Engineering.
6. Mathworks. *System Identification Toolbox*.
7. Ljung, L., *System Identification - Theory for the user*, ed. T. Kailath2012: Prentice-Hall, Inc.
8. Hulthén, E. and M. Evertsson, *Algorithm for dynamic cone crusher control*. Minerals Engineering, 2008.

DEVELOPMENT OF AN OPERATOR TRAINING FOR THE SWEDISH
AGGREGATES INDUSTRY

Asbjörnsson, G., Hulthén, E. and Evertsson, C. M., Development of an Operator Training for the Swedish Aggregates Industry, Presented at the 14th European Symposium on Comminution and Classification, Gothenburg, Sweden, 10-12 September 2015, Published in the conference proceedings.

Development of Operator Training for the Swedish Aggregates Industry

M.Sc. G. Asbjörnsson, Dr. E. Hulthén, Prof. M. Evertsson

Department of Product and Production Development, Chalmers University of Technology, Gothenburg, Sweden,

Abstract. In aggregates production and mining the operators are responsible for controlling and monitoring the process to maintain high plant throughput and safe operation. Operators have to make different decisions to control the process due to changed demand on the operation from both management and conditions of the process. The quality of the response and the time it takes for an operator to respond to altered demand relies on what information is available and the experience of the operator.

In this work a dynamic simulation platform has been developed to be used for operator training. Models for representing production units and process control for plant simulations have been developed and implemented in MATLAB/SIMULINK to simulate time-dependent plant behavior. Stochastic and scheduled events are included. The human-machine interface was developed using the human-machine interface software ICONICS.

The operators' cognitive process, in interpreting the plants semantic, has been studied by observations and with informal interviews with operators. This was done to get information about the daily operation and the problems that occur in the process. By interacting with operators that experience different physical interactions with the process; more qualitative e-learning software for supporting operator training in a dynamic operator environment could be developed. The quality of the operator training environment was evaluated with a usability study that was performed with operators and others within the production. The process performance was evaluated with a proposed performance function to compare different operation setups.

Keywords: Dynamic Simulation, Operator Training, Information system, Human-machine interface, Process control

INTRODUCTION

In aggregate production and mining the operators are responsible for controlling and monitoring the process to maintain high plant throughput and safe operation. Operators have to make different decisions to control the process due to changed demand on the operation from both management and conditions of the process. The quality of the response and the time it takes for an operator to respond to altered demand relies on what information is available and the experience of the operator.

In this work a dynamic simulation platform has been developed to be used for operator training for the Swedish Aggregate Producers Association (SBMI). Models for representing production units and process control for plant simulations have been developed and implemented in MATLAB/SIMULINK to simulate time-dependent plant behavior. Stochastic and scheduled events are included. The human-machine interface was developed using the human-machine interface software ICONICS.

The operators' cognitive process, in interpreting the plants semantic, has been studied by observations and with informal interviews with operators. This was done to get information about the daily operation and the problems that occur in the process. By interacting with operators that experience different physical interactions with the process; more qualitative e-learning software for supporting operator training in a dynamic operator environment could be developed.

Human Factors in the Process

In crushing plant like other complex production systems the operator can interact in different ways with the physical system. For a control room operator, the operator interacts with the process through the operator-interactive computer, where the operator interacts with the system using the human-machine interface (HMI) or Supervisory Control And Data Acquisition (HMI/SCADA), which in turn communicates with the process-interactive computer (Stahre, 1995).

In Bainbridge (Bainbridge, 1983) the dilemmas are discussed that faces the operator when it comes to higher degree of automation. When the level of automation increases, the role and responsibilities of operators' changes. With high level of automation the operator role becomes more supervisory and monitoring. These arguments supports the importance of maintain manual skills, as well as the cognitive skills for scheduling and diagnosis,

In Li, et al. (Li, Powell, & Horberry, 2012) the limitations regarding HMI are described using a simplified human supervisory model. The model consists of four different phases of human interaction with displays: detection, analysis, action and evaluation. In this study the authors identified several limitations when it comes to operator interacting with the process, one of the being operator training. Li states that the lack of systematic training is probably the key bottleneck for enhancing the capacity of the human operator when it comes to control needs of the automation system.

METHOD

The simulator used during this study has been developed in MATLAB/SIMULINK at Chalmers University of Technology. The simulator has previously been used to validate dynamic plant performance at a large mineral plant struggling to keep a stable process (Asbjörnsson, Hulthén, & Evertsson, 2013), for process Optimization (Hulthén, Asbjörnsson, & Evertsson, 2012) and for Operator training. (Asbjörnsson, Hulthén, & Evertsson, 2012)

Process Model

Each equipment model is an independent entity; the communication between models is therefore standardized. The data flows from one model to another and is transformed as it moves through the plant model. This data contains important information about the material which determines the performance of the system. This includes information about the particle size distribution ($PSD_i(t)$), the mass-flow ($\dot{m}(t)$) and properties of the material ($y_i(t)$). Each model's output is bundled together into a single vector which is communicated to the next model which in turn extracts the necessary information.

One of the fundamental principles of simulating dynamic systems is the conservation of mass. In a dynamic simulation, the constraint for mass-balance is solved with the accumulation of material according to Eq. 1. The time derivative of the mass in the system, $dm(t)$, is therefore a result of the difference of the mass-flow into the system ($\dot{m}_{i,in}(t)$) and the mass-flow out of the system ($\dot{m}_{j,out}(t)$).

$$\frac{dm(t)}{dt} = (\dot{m}_{i,in}(t) - \dot{m}_{j,out}(t)) \quad (1)$$

The performance of the screens is modelled with a Reid-Plitt efficiency curve and the performance of the crushers was empirically mapped. The quality of the aggregates is important for aggregate producers. To model the form factor of the aggregate a model proposed by Bengtsson was implemented, Eq 2. (Bengtsson, 2009). Where the shape F is a function of CSS , x average particle size and product size p .

$$F(\bar{x}, CSS, p) = \frac{\alpha_1}{\bar{x}} \left(\frac{\alpha_2 \bar{x} + \alpha_3}{CSS} \right) p^2 - \left(\frac{\alpha_2 \bar{x} + \alpha_4}{CSS} \right) p + \alpha_2 \bar{x} \quad (2)$$

The simulated processes used in this study consists of a tree different plants layouts. Two layouts are traditional for aggregate production and one aims the represent a mining application, see FIGURE 1-3. Most focus was on a single stage crushing in a small sized aggregate production which produces 2 different products: a coarse product and a fines product. The process consisted of a single crusher (36" Hydrocone), single screen, 8 conveyors and a material source. An overview of the process can be seen in Figure 3.

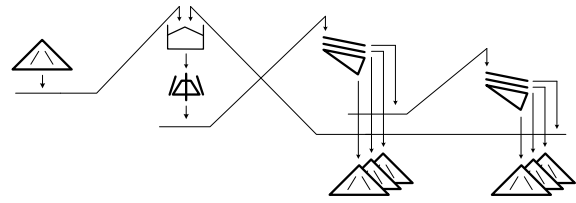

FIGURE 1. Layout of a stationary crushing process.

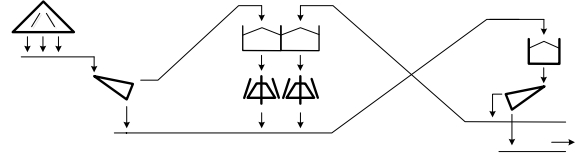

FIGURE 2. Process layout for a mining application.

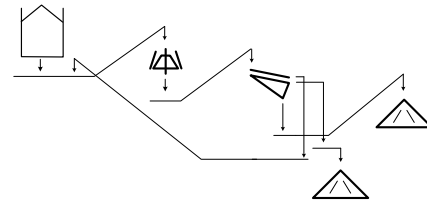

FIGURE 3 Process layout for a single stage aggregate production.

Human-Machine Interface

Multiple Human-Machine-Interfaces (HMIs) were developed in ICONICS GENESIS 64 which is a windows based application. The HMI communicates with the MATLAB/SIMULINK process model via Open Platform Communications (OPC) and sends the data to a SQL server.

All HMI's were published using HTTP and are therefore accessible with a standard web browser. FIGURE 4 and FIGURE 5 shows two of the HMI that were developed for the purpose of this study (ICONICS, 2012).

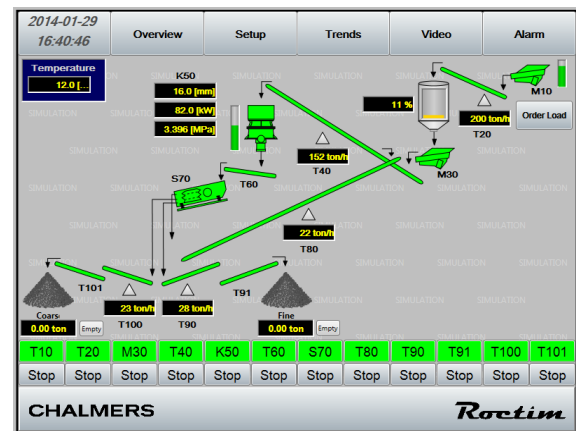

FIGURE 4. An overview interface developed to illustrate the status of the process.

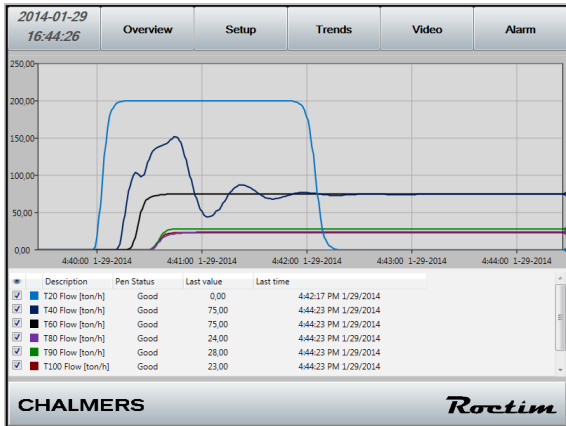

FIGURE 5. A process data interface developed to visualize the flow in the process.

The HMI includes an overview, setup, process data logger, CCTV and an alarm page. Drop down menus from setup and the data logger page provided the operator with more specific information, such as calibration routines.

System structure

The system structure utilized is a three-tiered distribution: Presentation layer, Application layer and Data management layer, FIGURE 6.

In the presentation layer is a Thin-Client architecture, the operator or supervisor can access the HMI on a client's PC without an installation of a third-party software. By using a standard web browser the operator can access production reports, HMI graphics, historical trends and alarms in real-time from anywhere. The accessibility is dependent on set security level for the user which is different between the operator and the supervisor of the training.

The process logic of the operator training is within the application process layer. MATLAB/SIMULINK runs continuous and discrete simulations and the output is dependent on the operator's setup of the process and his interaction with it.

The data management layer allows for data storage of the selected OPC tags that is communicated between the HMI and the MATLAB/SIMULINK model.

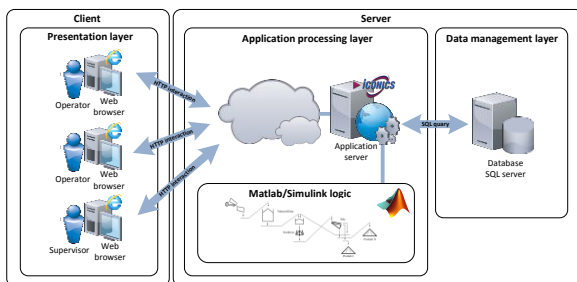

FIGURE 6. A schematic view over the three-tier application structure.

USABILITY STUDY

A usability study was conducted at the Swedish Aggregate Producers Association course "Production I" which offers training for operator and management. The third iteration of operator training was conducted with 18 participants with different backgrounds, including, but not limited to: operators, plant managers and truck drivers. The study was divided up into following sections:

- Navigating the display
- Setting up the processes with regards to set quality requirements
 - Particle size distribution
 - Shape
- Manually operating the processes
- Using automatic regulatory controllers
- Real-time Optimization
- Handling disturbances
- Calibration routines
- Troubleshooting alarms

Training overview

The participants were instructed to start by selecting appropriate setup for the process to produce 11/16 product according to Gc80/20 requirements (Swedish Standards Institute, 2007), given a certain simplified crusher performance, shown in FIGURE 7 and FIGURE 8.

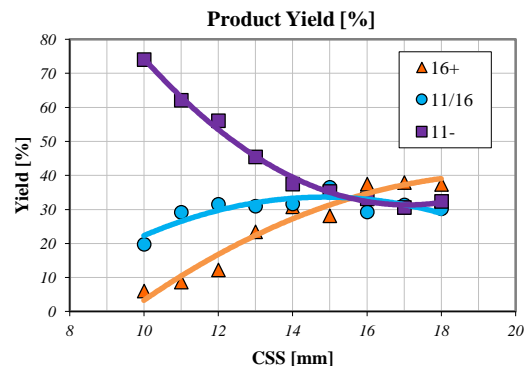

FIGURE 7. Product yield under different CSS.

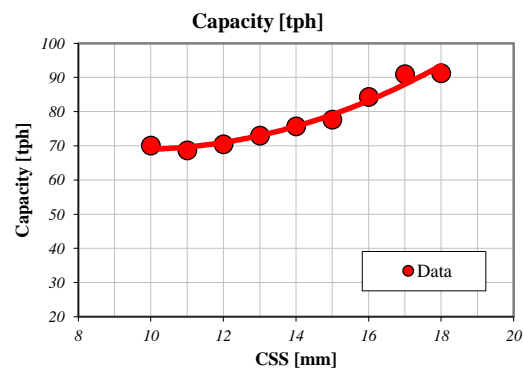

FIGURE 8. Capacity under different CSS.

Only selecting the best possible solution using the particle size distribution, FIGURE 7, would suggest that 15 mm CSS would produce largest amount of 11/16 product but putting in crusher capacity, FIGURE 8, as a second variable gives an optimum around 17 mm.

The participants were instructed to start up the process manually and maintain stable production for specific time period by adjusting the fed rate into the circuit. An example is shown in FIGURE 9 where after approximately 1800 sec the process as reach stable operation. If however, it was left unattended the crusher would fill or run empty over a time and then initiate an alarm.

By operating the process with the automatic regulatory control activated instead of manually the participants can adjust the set point for the PI controller, compared to trying to maintain constant level manually. In FIGURE 10 a results from a disturbance is depicted which caused the mantle to move down and increase the CSS for a short time.

The process from FIGURE 2 is used due to the unstable nature of the process layout. Standard configuration of PID loops and interlock cause the process to fluctuate. Different setup will however change the frequency of fluctuation. In FIGURE 11 typical fluctuation for the process in FIGURE 2 is illustrated.

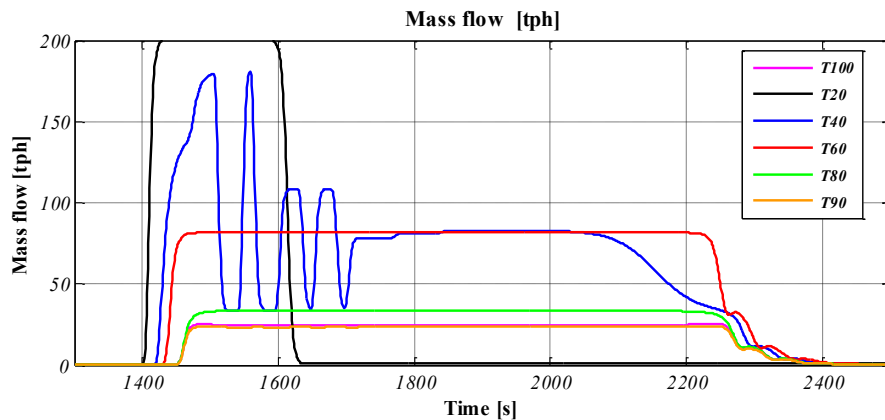

FIGURE 9. Mass flow manually stabilized by altering feeder frequency.

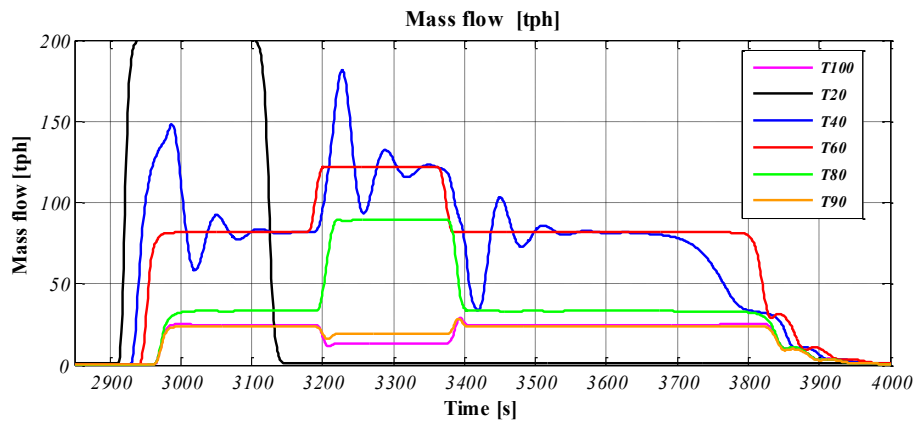

FIGURE 10. Operating the process with the PI controller active and adjusting CSS.

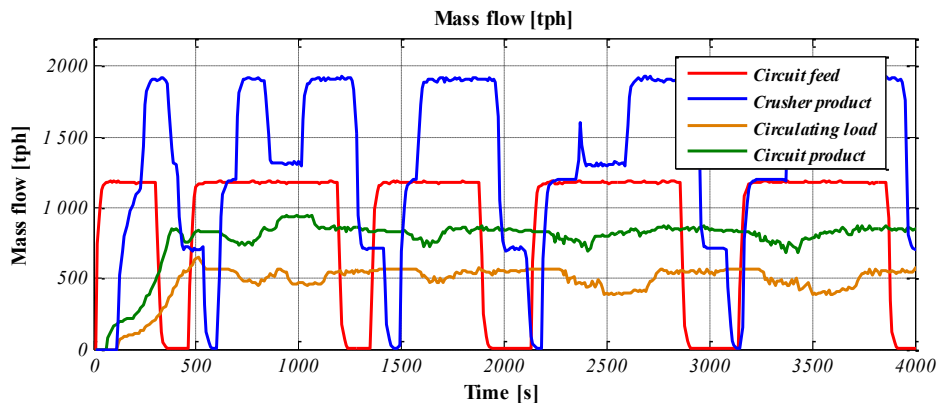

FIGURE 11. Process fluctuation in minerals processing plant illustrated in Figure 2.

OPERATOR PERFORMANCE EVALUATION

Each run was logged for comparison of individual groups. Since each groups was allowed to vary the feed into the circuit as well as settings on crusher and screens the participants could find a best possible solution to their capabilities in reading the datasheets and evaluating the process while operating, Eq 3.

$$Performance = \frac{m_p(1 - \bar{q}_{shape}) \sum_{t_1=0}^{t_2} (t_{psd})}{t_{total}} \quad (3)$$

The variable m_p is the total amount of material produced during the exercise while q_{shape} and t_{psd} are product quality when it come the particle shape and the amount of over- and undersize. A penalty function was formulated to estimate the reduced performances of quality requirements were violated.

Group 1 produced in total 35.35 tons in 1 hour and 30 minutes, which is 23.56 tph on average. During that time the had an average shape quality of 5 % and were within the set requirement 84 % of the time as illustrated in FIGURE 12 and FIGURE 13. Giving the performance value of 18.8 tph.

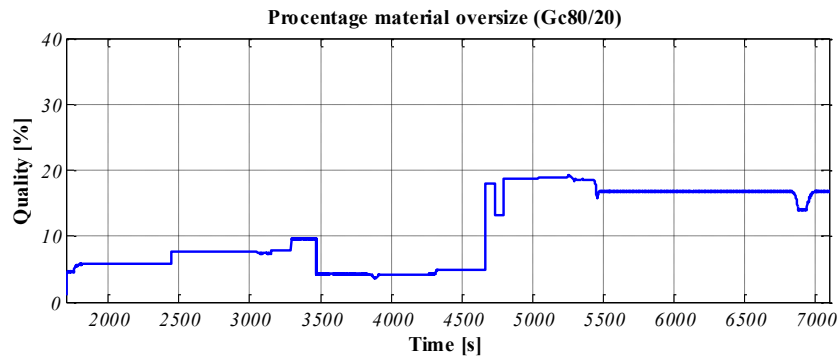

FIGURE 12. Percentage oversize in the product

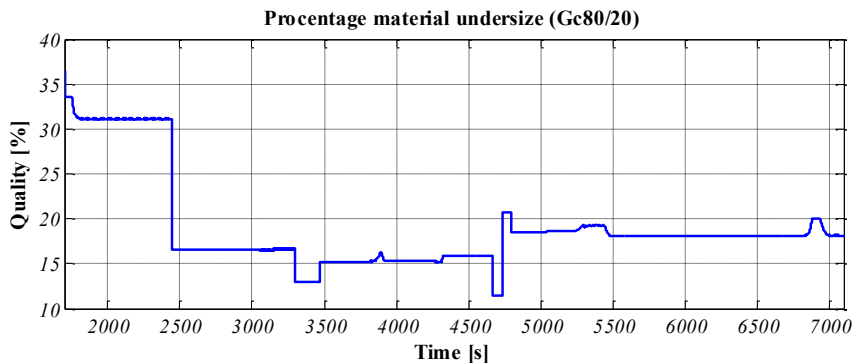

FIGURE 13. Percentage undersize in the product.

CONCLUSIONS

The operators' capacity to ensure safe and an efficient production is of high importance. In this study vital information for further development of qualitative e-learning software for supporting operator training in a dynamic operator environment has been collected.

From previous operator training cases the following aspects were addressed

- Quality factor – Feedback to operator about the quality of the product being produced, *i.e.* the amount of over- and undersize and an indication of the shape of the material.
- Process Optimization – Introducing process optimization and visualize the process while the algorithm is locating of optimum process parameters.
- Complex systems – Introducing more complex systems for a deeper understanding of operating a large scale system
- Daily operation issues such as: selecting appropriate unit configuration, calibration, handling feed to the circuit and handling alarms

For the latest iteration the three areas that were identified as being insufficient in the overall impression were:

- Navigating the HMI
- The selection of tasks
- Running the process manually

The low impression on navigating the HMI and running the process manually were highly correlated in the course evaluation. Running the process manually requires the participants to switch frequently between the Overview window, the Configuration window and the Trend window. In Watts-Perotti and Woods (Watts-Perotti & Woods, 1999) this is described as “getting lost phenomenon” and “display thrashing”. Keeping information separately increases the demand on interface management from the participants. The focus on the task itself is therefore reduced since part of the participants’ memory and attention is on locating information and finding out how to interact with the process

How the information and where the information is presented is essential for operators cognitive capability. The interface that the operator has towards the process should support the operator in detection, analysis, action and evaluation of the process, not increase the mental load. Locating more of the essential tabs and variables in the main display menu would reduce the need of navigating through the menus to find relevant information. Too much information on a small display can however also have negative effects

The information collected during the usability study gave a valuable feedback regarding the development of the operator training. The development will continue in creating an easily accessible operator training that support and trains the operators’ cognitive capabilities in operating crushing plants.

ACKNOWLEDGMENTS

This work has been performed within the Sustainable Production Initiative and the Production Area of Advance at Chalmers; this support is gratefully acknowledged. The authors wish to thank the Hesselman Foundation for Scientific Research and the Swedish national research program MinBaS (Minerals, Ballast, and dimensional Stone) for its financial support. Special Thanks to Anton Hjalmarsson at Chalmers University of Technology.

REFERENCES

- Asbjörnsson, G., Hulthén, E., & Evertsson, M. (2012). *An On-line Training Simulator Built on Dynamic Simulations of Crushing Plants*. Paper presented at the 15th IFAC symposium on Control, Optimization and Automation in Mining, Mineral and Metal Processing., San Diego, USA.
- Asbjörnsson, G., Hulthén, E., & Evertsson, M. (2013). Modelling & Simulation of Dynamic Crushing Plant Behaviour with MATLAB-Simulink. *Minerals Engineering* 43-44, 112-120.
- Bainbridge, L. (1983). Ironies of Automation. *Automatica*, 19(6), 775-779.
- Bengtsson, M. (2009). *Quality-Driven Production of Aggregates in Crushing Plants*. PhD, Chalmers University of Technology.
- Hulthén, E. (2010). *Real-Time Optimization of Cone Crushers*. PhD, Chalmers University of Technology, Göteborg.
- Hulthén, E., Asbjörnsson, G., & Evertsson, M. (2012). *Tuning of real-time algorithm for crushing plants using a dynamic crushing plant simulator*. Paper presented at the Comminution '12, Cape town, South Africa.
- ICONICS. (2012). GENESIS64 Standard Training Manual.
- Li, X., Powell, M. S., & Horberry, T. (2012). Human Factor in Control Room Operations in Mineral Processing: Elevating Control From Reactive to Proactive. *Cognitive Engineering and Decision Making*, 6, 88-111.
- Plitt, L. R. (1971). The analysis of solid-solid separations in classifiers. *CIM Bulletin*.
- Reid, K. J. (1971). Derivation of an equation for classifier -reduced performance curves. *Can Metall Quart*, 10, 253-254.
- Rosin, P., & Rammler, E. (1933). The Laws Governing the Fineness of Powdered Coal. *Journal of the Institute of Fuel*, 7, 29-36.
- Stahre, J. (1995). *Towards Human Supervisory Control in Advanced Manufacturing Systems*. Chalmers University of Technology - Production Development, Chalmers University of Technology - Production Development.
- Swedish Standards Institute, S. S. (2007). SS-EN 13242+A1:2007 *Ballast för obundna och hydrauliskt bundna material till väg- och anläggningsbyggande* (Vol. SS-EN 13242+A1:2007).
- Swedish Standards Institute, S. S. (2008). Ergonomic design of control centres - Part 5 (Vol. ISO 11064-5:2008).
- Watts-Perotti, J., & Woods, D. D. (1999). How Experienced Users Avoid Getting Lost in Large Display Networks. *INTERNATIONAL JOURNAL OF HUMAN-COMPUTER INTERACTION*, 11(4), 269-299.

MODELLING OF DISCRETE DOWNTIME IN CONTINUOUS CRUSHING
OPERATION

Asbjörnsson, G., Bengtsson, M., Hulthén, E. and Evertsson, C. M., Modelling of Discrete Downtime in Continuous Crushing Operation, Presented at the 5th International Computational Modelling Symposium, 9-10 June 2015, Falmouth, UK, Submitted to Minerals Engineering (Journal), July 2015.

Modelling of Discrete Downtime in Continuous Crushing Operation

Gauti Asbjörnsson MSc, Magnus Bengtsson Ph D, Erik Hulthén Ph D, and Magnus Evertsson Ph D
Product and Production Development, Chalmers University of Technology, SE-412 96 Göteborg, Sweden
Email: gauti@chalmers.se

Abstract

Crushing is a harsh process and production units are subjected to wear and failure over time which will reduce the overall performance of the plant. To achieve optimum process performance, both time dependant process dynamics and operating conditions should be taken into account.

In this paper the aim is to create a framework for simulating the process from a more operational perspective to evaluate process performance and process optimum for different operational scenarios. The objective is to model and simulate the discrete phenomena that can cause the process to alter performance and implement it with dynamic process simulations. A method for combining discrete probability simulations with time-continuous simulations for process evaluation and optimization is presented.

The proposed framework demonstrates a systematic approach to evaluate the process performance and locating optimum process configuration, for a given condition. The developed models can be used to optimize different aspects of the operation depending on the defined objective function and the system boundaries. Optimization of process throughput by manipulating configuration of both the grizzly and the crushers, as well as the time between calibrations has been illustrated in this paper. Adjusting the process continuously and calibrating it at the appropriate time can have major benefits when it comes to the process availability and utilization, increasing performance by 4.1-9.3 % in these cases. Evaluation of process robustness with regards to different maintenance strategies and process variation gave an indication of the process and unit performance under a long operating period. By combining discrete and dynamic simulation, a higher simulation fidelity can be achieved to provide a more operational perspective to the optimization and process analysis.

Keywords: Dynamic Simulation, Discrete event simulation, Optimization

1. Introduction

Crushing is a harsh process and production units are subjected to wear and failure over time which will reduce the overall performance of the plant. To achieve optimum process performance, both time dependant process dynamics and operating conditions should to be taken into account when modelling. According to Svedensten the change in performance due to wear differs greatly depending on the application, feed material and equipment (Svedensten, 2005). In Svedensten's work the wear in a crushing process was presumed to create a normal distribution of the process performance. To estimate the variation in process performance Monte-Carlo simulations were run for selected parameters and a steady-state process model was used to estimate the process performance for each condition (Svedensten, 2004). Inadequate bulk material handling in bins crushers and screens will affect the process performance as well. Material flows in bins where there are multiple inflows and multiple outflows can cause problems in the downstream process due to segregation within the bin. There are documented cases where realigning and redistributing of material entering larger bins has resulted in a higher plant capacity and more stable operation (Powell et al., 2011). In Evertsson et al. a classical fatigue life theory was used to illustrate the importance of actively monitoring the crushers operating conditions. If not monitored appropriately the consequence will be a high probability of a reduced service life, i.e. equipment failure (Evertsson et al., 2014). From Evertsson et al. and Quist, it is clear that the nominal pressure in the crushing chamber is a function of the compression ratio and the width of the particle size distribution (Evertsson et al., 2014; Quist and Evertsson, 2010). There will however always exist some pressure fluctuation which is dependent on the distribution and the segregation in the crushing chamber.

Overall Equipment Effectiveness (OEE) originates as part of Total Productive Maintenance (TPM). The OEE method is a measure of process effectiveness and gives a good indication of the state of the process performance

by dividing the process effectiveness in availability, utilization and quality, Eq (1)-(3). In Kullh and Älmegran the process metric is described and the how different downtimes quantifying the OEE (Kullh and Älmegran, 2013). In Powell M.S. et al. the OEE was used to indicate crusher performance in a platinum production. (Powell et al., 2012). The OEE provides a qualitative indicator that can be used to evaluate different process configurations and operational approaches.

$$OEE = Availability \cdot Utilization \cdot Quality \quad (1)$$

$$Availability = \frac{Net\ available\ time - downtime\ losses}{Net\ available\ time} \quad (2)$$

$$Utilization = \frac{Net\ operation}{Gross\ operation} \quad (3)$$

The changes within the process can be considered to be stochastic or deterministic depending on the phenomenon. Stochastic events are unplanned and undesirable, such as equipment failure. Deterministic events are planned and scheduled such as breaks, shifts, and maintenance which aim to maintain a reliable and productive process. Discrete events are usually described by different phases: time between failures (TBF), time to failure (TTF), downtime (DT), Waiting time (WT) and time to repair (TTR) (Banks et al., 2010). The maintenance strategies in crushing are dominated by corrective maintenance and preventive maintenance. Corrective maintenance means repairing the machine or component at the time of failure. While preventive maintenance stands for periodic maintenance to avoid failure, i.e. components are changed before they break (Kenne and Nkenungoue, 2008). Additional approaches include: Predictive maintenance, Opportunistic maintenance and Condition-based maintenance (Bevilacqua and Braglia, 2000). The use of discrete event models in mining and comminution simulations has been proposed to represent different discrete operations. These discrete operations include dispatching of trucks, truck and shovel operation, truck dumps, batch processes, conveying, feeder and bin interlocks, process variations, expert system rules and scheduled and unscheduled downs. (Herbst et al., 2012; Reynolds, 2010; Salama et al., 2015). Optimization of discrete system in mining is traditionally focused on equipment selection and selection of equipment quantity by defining equipment operation specification such as: average frequency of arrival, queue time, loading time, hauling time and dumping time (Salama et al., 2015). (Hashemi and Sattarvand, 2014).

The use of discrete event simulation incorporated in continuous simulation in crushing is steadily increasing. According to Herbst the combination of discrete event simulation and continuous simulation is essential to evaluate the overall production, since maintenance, downtime events, geometallurgy, plant performance and plant design are intimately linked (Herbst et al., 2012). Reynolds claims that changes in process configuration or operational mode can have significant impact on the process and the inability to assess process dynamics and variability will lead to reliance on a judgement availability figure, historical sources and re-rated nominal plant performance (Reynolds, 2010). Dynamic process models provide a higher fidelity of the process and can expose discrepancies, over/under design of units, abnormal operating modes and other shortcomings that are time dependant (Jonas, 2004) ,while the discrete event simulation can uncover process over/under utilization of equipment and improve maintenance scheduling.

In this paper the aim is to create a framework for simulating the process from an operational perspective to evaluate process performance and process optimum for different operational scenarios. The traditional use of a hybrid discrete-dynamic simulation has been to evaluate different what-if scenarios with predefined cases, not to find an optimum configuration or the most profitable operational approach. The objective is to model and simulate the discrete phenomena that can cause the process to alter performance and implement it with dynamic process simulations. By combining discrete and dynamic simulation the aim is to increase the fidelity of the simulation and be able to provide a more operational perspective to the optimization and process analysis.

2. Modelling

The objective of this study is to create a framework for modelling the process from a more operational perspective to evaluate process performance and process optimum for different operational scenarios by integrating discrete event based and continuous time based models. This is achieved by running a probabilistic discrete event simulation to provide input into a continuous time based crushing plant model that represents a conceptual closed-loop circuit configuration containing feeders, two bins, conveyors, two CH660 hydrocone crushers with medium and fine crushing chambers, a grizzly and a single deck screen, as shown in Figure 1. The following sections will describe the dynamic modelling and the discrete event modelling in detail. The modelling work in this study has been done using MATLAB/Simulink and SimEvents.

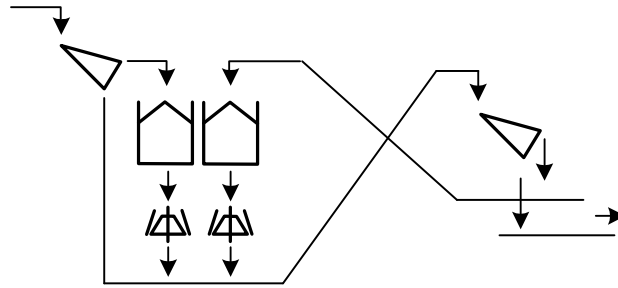

Figure 1. A closed loop secondary crushing circuit.

Dynamic process modelling

Crushing plants like any other production process are affected by changes over time. To be able to model the dynamic behaviour of any system an understanding of the entities and interaction is essential. System complexity is dependent on the level of detail. Simple models are single input single output (SISO) but that is seldom the case in reality, actual systems are often complex with multiple input, where an output (y) is a function of multiple input variables (u_1, \dots, u_n) and internal state variables (x_1, \dots, x_n) which are time dependent (t), Eq. (4) (Ljung and Glad, 2002).

$$\begin{aligned} \frac{dx_i}{dt} &= f_i(x_1(t), \dots, x_n(t), u_1(t), \dots, u_m(t)) \\ y_i(t) &= h_i(x_1(t), \dots, x_n(t), u_1(t), \dots, u_m(t)) \end{aligned} \quad (4)$$

To be able to simulate plant dynamics, mathematical models for every production unit, e.g. crushers, screens, conveyors, silos, etc., has to be created. The models describe the changes in flow and particle size of the material travelling through the plant. Plant modelling generally focuses on single production unit and plant configuration, but due to accumulation of material the flow needs to be controlled in dynamic modelling. Additionally the process can be sensitive to start ups, discrete events, wear, segregation, natural variation and other effects not uncommon in daily operation, all depending on interaction between single production units, plant configuration, plant control and diverse events and disturbances that can influence the process, Figure 2. In order to model an entire plant, the unit models are connected together according to the user preference and configured with a set of defined parameters. The models share the same type of connections. i.e. any unit can be connected together with ease and material properties are inherent for subsequent units.

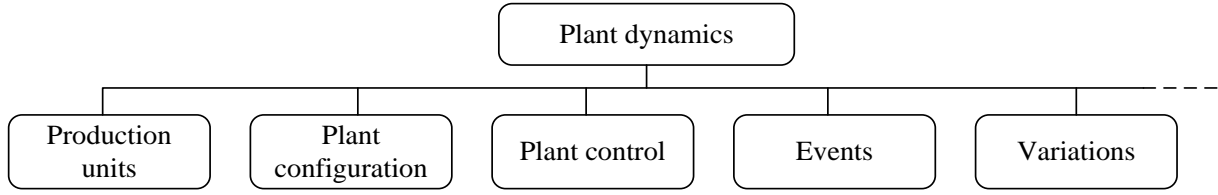

Figure 2. Factors influencing plant dynamics (Asbjörnsson et al., 2012).

The model for size reduction used in this study is defined as mechanistic model or semi-empirical, i.e. the aim is to describe the physical phenomena of the system together with empirically fitted parameters. The crusher model is based on the crusher model presented by Evertsson (Evertsson, 2000). The size reduction process is broken down into a finite number of compressions which is a static nonlinear function of crusher geometry, closed side settings, eccentric throw, eccentric speed and material properties. The change in the crushers CSS is represented with the linear displacement model. The change in crusher hopper level is modelled as a non-linear function estimated from the crusher geometry (Sbárbaro, 2005). The function used to describe the level in the crusher (x) is a function of available crusher hopper volume (V), material density ρ , the nonlinear function representing the geometry of the crusher ($f(x)$) and the accumulation of the mass flow in to the crusher (\dot{m}_{in}) and the mass flow out from the crusher (\dot{m}_{out}), Eq. (5) and Figure 3. The supporting beams for the upper shell are not included in the figure. The bins were modelled as perfectly mixed tanks, Eq. (8).

$$x(t) = x(t_0) + \frac{f(x)}{V\rho} \int_{t_0}^t (\dot{m}_{in}(t) - \dot{m}_{out}(t)) dt \quad (5)$$

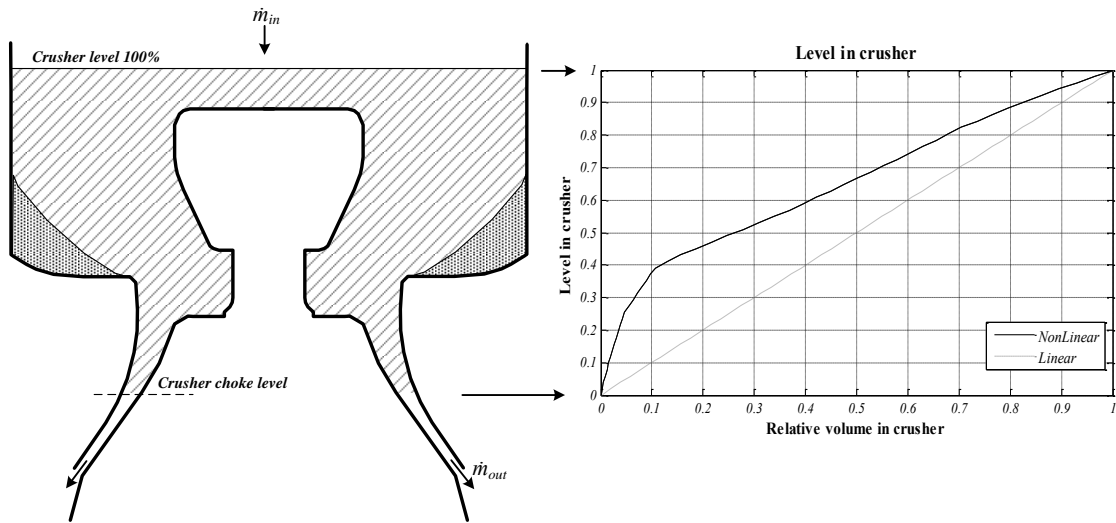

Figure 3. The relation between occupied volume and level in the crusher. The available volume is marked as the stripped area while dead volume is marked as the spotted area.

The crusher capacity is estimated with Evertsson's crusher flow model. Eq. (6). The flow model uses the bulk density (ρ), utility (η) and by integrating the velocity v and area A at the crusher's smallest cross-sectional area (between the angle 0 and α_c and radii R_0 and $R_i(\alpha)$) at the choke point, shown in Figure 3, the crusher capacity can be calculated. The transient behaviour of crusher capacity as it is filling is given by Eq. (7). Where $x(t)$ is the level in the crusher and a is the parameter characterising the response.

$$Capacity_{max} = \eta\rho_{Bulk} vA = \eta\rho_{Bulk} \int_0^{\alpha_c} \int_{R_i(\alpha)}^{R_0} v(\alpha) r dr d\alpha \quad (6)$$

$$Capacity(t) = Capacity_{max} (1 - e^{-ax(t)}) \quad (7)$$

The residence time of the material properties ($\gamma_i(t)$) is directly related to the mixing of the material $m(t)$ in the hopper, the flow of incoming feed $\dot{m}_{i,in}$, Eq. (8), the crusher's capacity and the time it takes the material to travel through the crusher chamber, which is a function of particle average vertical velocity and mantle height.

$$\frac{d\gamma_i(t)}{dt} = \frac{\dot{m}_{i,in}(t)}{m(t)}(\gamma_{i,in}(t) - \gamma_i(t)) \quad (8)$$

The pressure distribution on mantle is estimated using a function derived by Evertsson and Lindqvist (Evertsson and Lindqvist, 2002), Eq. (9). The wear rate in the crusher models is set as proportional to the compressive pressure Eq. (10) and no sliding motion of the particles is assumed. (Lindqvist et al., 2006). Where a_i are fitted parameters, σ is the distribution of the particle feed size, s_x is the compression ratio in every crushing zone, p is the pressure, W is the wear resistance coefficient and w is the wear rate. The crusher pressure will always vary depending on the quality of the feeding condition. A sinusoid pressure fluctuation with the amplitude of 0.5 MPa was added to the nominal pressure in the crusher model.

$$p(s_x, \sigma_x) = a_1 s_x^2 \sigma_x^2 + a_2 s_x^2 \sigma_x + a_3 s_x^2 + a_4 s_x \sigma_x^2 + a_5 s_x \sigma_x + a_6 s_x \quad (9)$$

$$\Delta w = \frac{P}{W} \quad (10)$$

The mechanical principles of a screen have been described in detail by Stafhammar (Stafhammar, 2002). The model describes the material stratification and probabilistic passage of the rock material along the screen deck. The screen and grizzly model used in this study is a Plitt-Reid efficiency curve (E_i) over the defined size fractions (x_i), Eq. (11). The transport delay (t_{screen}) of the material is however the length of the screen (L_{screen}) divided by the transport velocity, proposed by Stafhammar, which defines the average particle velocity as a function of screen frequency (f), screen throw (R) and screen slope (β) in Eq. (12). No wear is estimated for the grizzly or screen.

$$E_i = 1 - e^{-0.693 x_i^{5.846}} \quad (11)$$

$$t_{screen} = L_{screen} / (0.064\beta + 0.2)(380R - 0.18)(0.095f\beta^{-0.5} + 0.018\beta - 0.38) \quad (12)$$

The conveyors have been modelled with a constant time delay θ which depends on the conveyor velocity and length, Eq. (13).

$$y(t) = u(t - \theta) \quad (13)$$

To evaluate the stability of the process under different feeding conditions a wide variation of the feed size distribution for the process was modelled, Eq. (14) and Figure 4. The top size (x_{max}) and the 50% passage (x_{50}) of the material were varied between 25% below and above the defined size distribution. The slope b was kept constant. The defined particle size distribution was used as a reference in each optimization.

$$f(x) = \left(\frac{\ln\left(\frac{x_{max}}{x}\right)}{\ln\left(\frac{x_{max}}{x_{50}}\right)} \right)^b \quad (14)$$

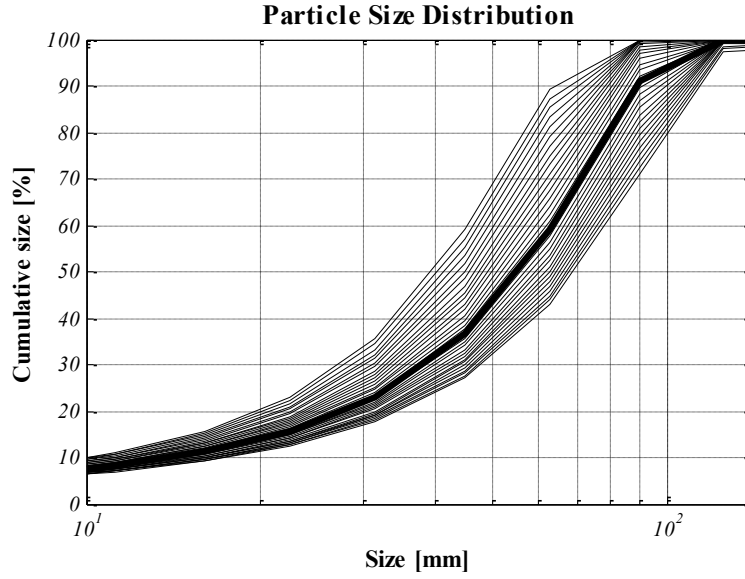

Figure 4. Systematic variation in the incoming feed to evaluate process stability. The thick line represents the particle size distribution that was used during the optimizations.

The process control is designed to ensure safe operation while striving for high product quality and high production throughput by keeping the process stable. The level of control is dependent on the complexity of the process and the control system designer’s ability to provide an appropriate solution to the task. Most crushing plants are usually equipped with some sort of feedback control to stabilize the material flow in the process. In order to design a PI controller for the process a linear approximation was done around the operational condition. Linear approximation has been used by Sbarbaro (Sbárbaro, 2005), Itävuo (Itävuo et al., 2014) and Airikka (Airikka, 2013) in their controller tuning. The controller in this study is designed to maintain a certain level in the bin above the coarse crusher. A linear approximation for that part of the circuit is shown in Figure 5.

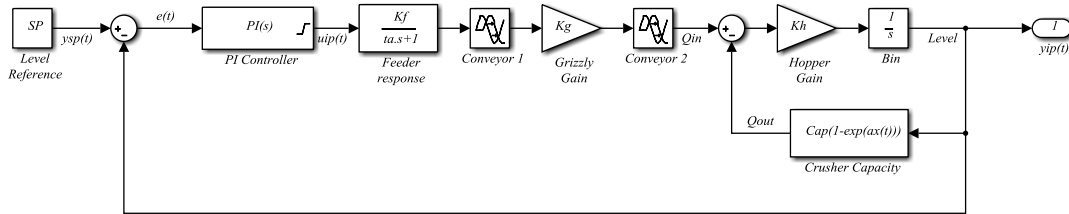

Figure 5. Linear approximation of the controlled part of the process.

The transient behaviour of the feeder is expressed with the following first order transfer function $G(s)$ in Eq. (15). The parameter s is the Laplace operator, θ is the delay, the time constant, which is denoted with a τ , is the time which the system takes to reach 63.2% of the final steady-state value $y(t)$, which is equal to the steady-state process gain K and the difference in the forcing input $u(t)$, shown in Eq. (15). In reality the feeders, especially vibrating feeders, are nonlinear and unsymmetrical when it comes to process behaviour (Itävuo et al., 2014).

$$G(s) = \frac{Y(s)}{U(s)} = \frac{K}{\tau s + 1} e^{-\theta s} \quad (15)$$

A large majority of industrial controllers are proportional-integral-derivative (PID) controllers and as high as 90-95 % of industrial controls are PID based (Airikka, 2013; Itävuo et al., 2014). However, the derivative term is usually not included as pointed out by Itävuo (Itävuo et al., 2014). PI controllers utilize the proportional and integral action, Eq. (17), to eliminate the error e between the set point y_{sp} and the process value y_{pv} , Eq. (16). PI controllers are adequate for first order processes (Åström, 1995), Eq. (15).

$$e(t) = y_{sp}(t) - y_{pv}(t) \quad (16)$$

$$u(t) = K_p e(t) + K_i \int e(t) dt \quad (17)$$

Multiple controller tuning methods have been described by Åström (Åström, 1995). The K_p and K_i parameters were automatically tuned using a Simulinks tuning toolbox. The model-based approach uses the defined transient response to estimate the controller's gains (K_p and K_i).

Discrete event modelling

A discrete event simulation (DES) model is used to simulate systems that only change at a discrete point in time. Each discrete event has specific attributes that determine the TBF and DT of each event or activity. All DES models are considered to be mutually exclusive events. Events such as upstream, downstream and maintenance are given static deterministic behaviour and will therefore not vary between each simulation. While mechanical failure is given a probability of failure determined by the maintenance strategy. In Figure 6 the principle for event generation, sorting and queuing with respect to TTF and DT is shown. The occurrences of the event are mutually exclusive and cannot happen at the same time. If an event is ongoing the event will be queued until the maintenance is available.

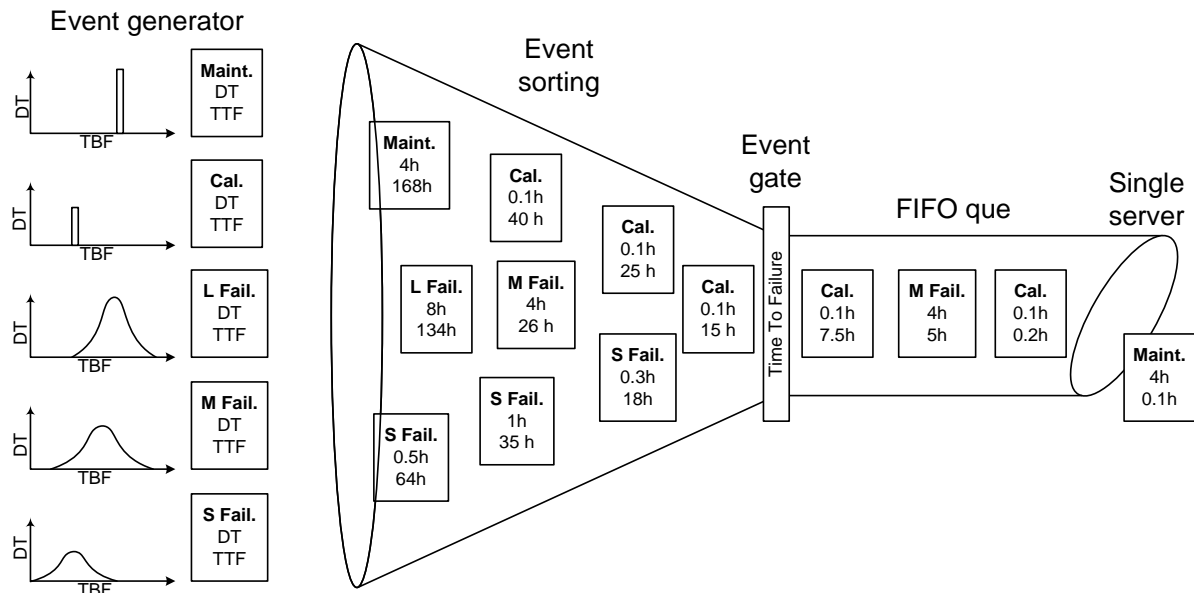

Figure 6. The principles of discrete event modelling for the process.

The following definitions and examples were used to define different discrete event in Table 1:

Table 1. Categorising the discrete events in the process.

Type	Probability	Description
External	Stochastic	Uncontrollable events outside the process
Upstream	Deterministic/Stochastic	Operational stops or standby due to lack of feed upstream
Downstream	Deterministic/Stochastic	Operational stops due to downstream process full or down
In-stream	Deterministic/Stochastic	Delay or standby due to lack of control
Failure	Stochastic	Break down that requires unscheduled maintenance
Maintenance	Deterministic	Scheduled maintenance

These disturbances will reduce the overall utilization of the process. To obtain a better prediction of a monthly operation the production is reduced with regards to upstream and downstream disturbance. In stream, mechanical and maintenance events are included in the simulation.

The production simulation is given three different probabilities of mechanical failure: low, medium and high risk. Figure 7 illustrates the difference in DT incidents that have occurred over one month. Upstream, downstream and external incidents are identical while the maintenance and failure are varied depending on how the operators maintain the process. For a preventive maintenance strategy large time and cost is spent on changing wear parts and adjusting the processes during predetermined service intervals with low risk of failure. During corrective maintenance however, less time is set up for service intervals and higher failure rate since the equipment is not changed until it breaks or is close to failing. An optimum solution is usually a combination of both strategies (Kenne and Nkenungoue, 2008) since frequently changing wear parts prematurely and process stops due to unforeseen equipment failure, are both detrimental for the process efficiency.

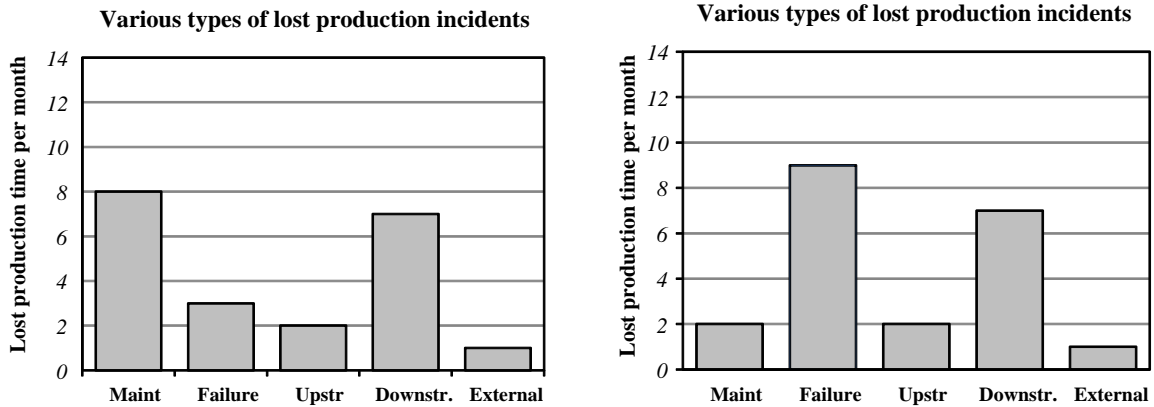

Figure 7. Illustration of the downtimes for corrective and preventive cases.

Mechanical failures in the process are included as stochastic events with probability of failure as a function of maintenance. The failure probability is modelled as Weibull distribution in Eq. (18) and Exponential distribution in Eq. (19) with SimEvents. The parameters k and λ describe the form of the distributions.

$$f(x, k, \lambda) = \frac{k}{\lambda} \left(\frac{x}{\lambda} \right)^{k-1} e^{-(x/\lambda)^k} \quad (18)$$

$$f(x, \lambda) = \lambda e^{-\lambda x} \quad (19)$$

Three different failure modes were modelled as stochastic events depending on the severity of the failure. Short breakdowns that cause a DT of 30 min – 2h were modelled with a Weibull distribution with MTBF, medium failures that take 2h – 4h and long breakdowns that take 4h – 12h were modelled with an Exponential distribution. Each failure has a set waiting time of 15 min, which includes detection time and time it takes to arrange the required maintenance. The distribution is illustrated in Figure 8.

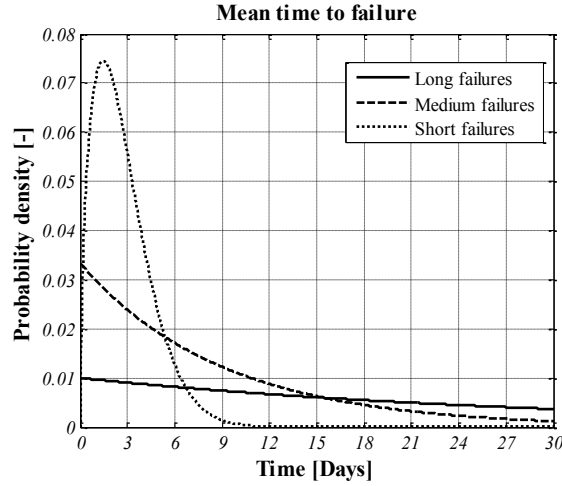

Figure 8. The different probability densities for failures.

3. Optimization

The production will be optimized for a maximum process throughput with regards to changes in the operating condition and discrete events. The optimization statement can be written in the following way, Eq. (20):

$$\begin{aligned}
 & \max_{x \in P} m_{product,h}(x, p) \\
 & \text{s.t.} \quad g_1(x) = Cr1_{Pres} - Cr_{Max} \leq 0 \\
 & \quad \quad g_2(x) = Cr2_{Pres} - Cr_{Max} \leq 0 \\
 & \quad \quad g_3(x) = 20 - Cr1_{CSS} \leq 0 \\
 & \quad \quad g_4(x) = 10 - Cr2_{CSS} \leq 0 \\
 & \quad \quad g_5(x) = 10 - Sc1_{Ap} \leq 0 \\
 & \quad \quad g_6(x) = 7200 - Cr1_{Cal} \leq 0 \\
 & \quad \quad g_7(x) = 7200 - Cr2_{Cal} \leq 0
 \end{aligned} \tag{20}$$

The optimization will give the optimum solution (x^*) for maximizing the production of material below 15 mm ($m_{product,h}^*$) which is the set requirement for the sub-sequential circuit. Parameter x is a vector of design variables while p is a vector of fixed parameters for the plant model. Inequality constraints $g_i(x)$ include the smallest close side settings ($Cr1_{CSS}$ and $Cr2_{CSS}$), the grizzly aperture ($Sc1_{ap}$), the crusher pressure ($Cr1_{pres}$ and $Cr2_{pres}$) and the shortest time between calibrations (TBC) ($Cr1_{Cal}$ and $Cr2_{Cal}$). The second screen aperture, the crushers' eccentric throw and crushers' eccentric speed are treated as equality constraints which are equal to 15 mm for the aperture, 44 resp. 40 mm for the eccentric throw and 300 rpm for the eccentric speed. For the second optimization routine the minimum time between calibrations is set to 2 hours.

For the optimization an evolutionary algorithm called genetic algorithm (GA) was used. The GA is a stochastic algorithm which has a high probability of locating a solution close to the global optimum. In a GA, a candidate solution to the problem at hand is represented as a fixed-length string of digits known as a chromosome. The chromosome, when decoded, generates an individual (in this case the process parameters x_i , Eq. (22)), which can be evaluated and assigned a fitness score based on its performance (Process performance). A population consisting of M individuals is maintained. All individuals are evaluated and assigned fitness scores, and new individuals are then formed through the procedures of fitness-proportional selection, crossover, and mutation (i.e. small random variations in the network, Eq. (21).

$$x_i = \text{random value } x(x_{i,\min} \leq x \leq x_{i,\max}) \tag{21}$$

The process, which is inspired by Darwinian evolution, is repeated until a satisfactory solution to the problem has been found. The number of chromosomes was set to 20 and target generations to 100. GAs will not be described in more detail in this paper. For detailed information concerning the use of GA in comminution, see Svedensten, Lee and Hulthén et al.(Hulthén et al., 2012; Lee and Evertsson, 2011; Svedensten and Evertsson, 2005)

4. Results

First simulation did not include any wear. This was to create a reference point for the rest of the simulation scenarios and to further tune the controllers around the operational condition. The average throughput from the circuit for 24 hours was 406 tph with standard deviation of 71 tph. The results from the first iteration are shown in Table 2.

Table 2. First optimization iteration – 8 hours base case scenario with no wear or events.

Variables	Grizzly	Crusher 1	Crusher 2
Limits	10-50 mm	20-40 mm	10-30 mm
x^*	Apert. – 20 mm	CSS – 28 mm	CSS – 19 mm

The process is under continuous variations in the incoming feed size distribution. To evaluate process robustness and the process ability in maintaining high process performance while operating at a constant CSS the feed size distribution was varied. In Figure 9 the mass flow per size class is illustrated. After a 10% increase in the size distribution, at a top size of 132 mm, the pressure limit in crusher 1 was violated resulting in an increased CSS for the larger feed size distributions. The crusher 1 will not be able to operate at a constant CSS if the feed size distribution will become too large. At a smaller particle size distribution the crusher could be operated at a smaller CSS.

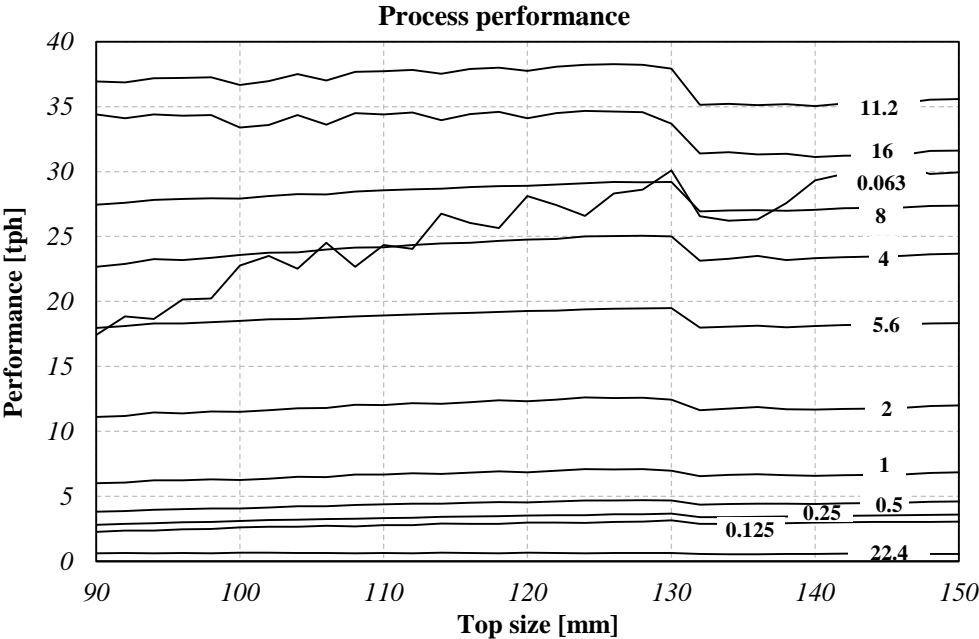

Figure 9. The process performance during different feed size distribution.

The second iteration included a wear rate in the crushing chamber. Each calibration was estimated to take 10 minutes and 50 h of production was simulated. The CSS for each crusher and the aperture for the grizzly from the previous optimization was used, since both crushers were close to their boundary condition regarding maximum allowed pressure and no wear is estimated on the grizzly. If the boundary condition had not been active it might have been beneficial to start with a smaller CSS. The average throughput from the circuit was 375.0 tph with standard deviation of 101.9 tph. The results from the second iteration are shown in Table 3.

Table 3. Second optimization iteration - 50 hours with 10 min calibration.

Variables	Crusher 1	Crusher 2
Limits	2-50 h	2-50 h
x^*	Cal – 11054 s	Cal – 21656 s

The third iteration includes a month of operation with calibrations and internal mechanical failure depending on the maintenance strategy. In Figure 10 the discrete incidents are illustrated for one of the scenarios. The different strategies are compared on the average throughput, the standard deviation of the production, the total DT of the process and the availability of the process, shown in Table 4. Each production is simulated to represent 30 days of continuous production or 720 hours. During the production external events, upstream production stops and downstream production stops count for 10 days of interrupted production DT, a total of 80 hours. This reduces the process availability to 89 %.

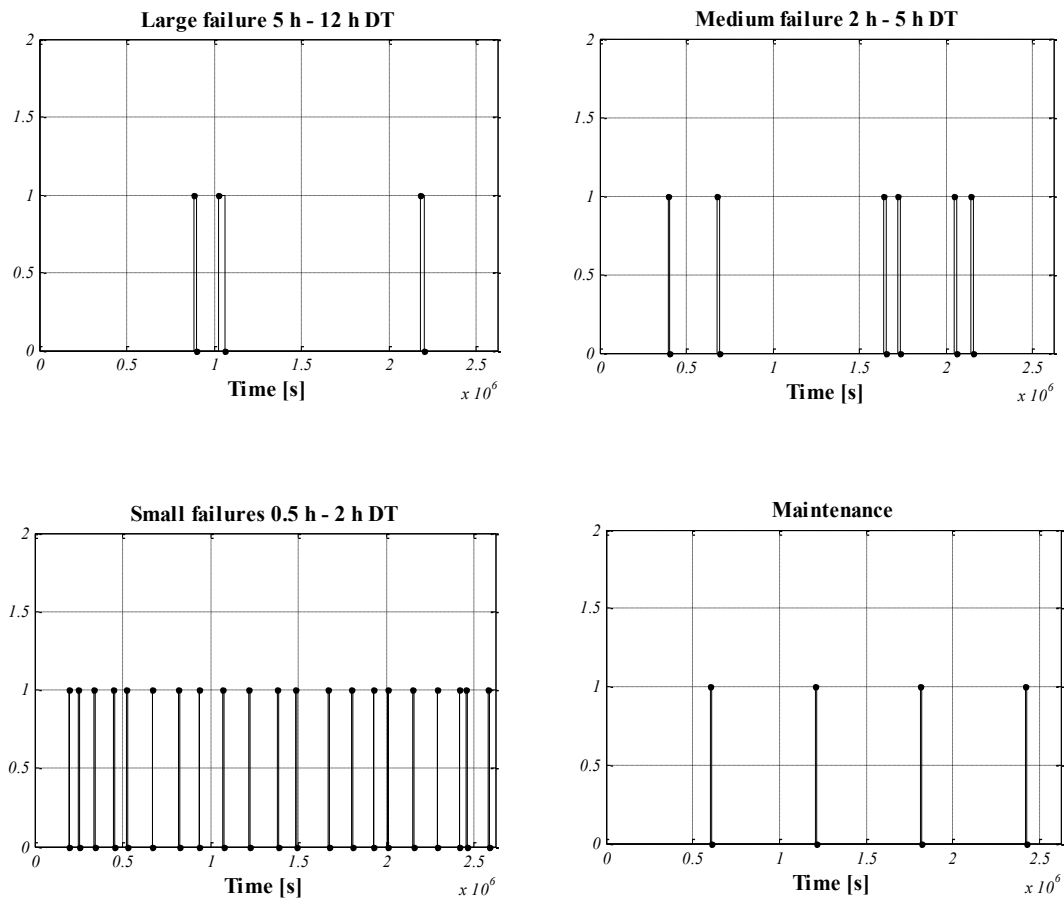

Figure 10. Discrete incidents during operation in the form of maintenance and failures.

For the simulated month of operation the start CSS for crusher one was set to 28 mm and to 19 mm for crusher two. 20 mm was set as the aperture of the primary screen. The calibrations were set to an interval of 14500 s for crusher 1 and 22000 s for crushers 2. Preventive approach achieved highest average throughput of 338.8 tph with process variation of 142.9 tph with total DT of 16.6 %. For corrective resp. combined approach the average throughput resulted in 325.7 tph resp. 333.2 tph. Shifting the focus from preventive maintenance to corrective maintenance the total DT of the process changed from 16.6 % to 20.3 %, as shown in Table 4. The cost of maintenance is not included in the simulation. Changing a wear part before its economical optimum will result in increased operational cost. The availability of the process is calculated by comparing the process gross operating time to the unplanned DT.

Table 4. Comparison of the different maintenance strategies for a one month simulation.

Strategy	Average Throughput	Standard deviation	Total downtime	Unplanned downtime
Preventive	338.8 tph	142.9 tph	16.6 %	6.5 %
Combination	333.2 tph	148.1 tph	18.1 %	8.9 %
Corrective	325.7 tph	154.4 tph	20.3 %	11.7 %

Calibrating the crushers is essential in order to keep the process operating at the highest possible throughput. The difference in OEE by calibrating the crusher at 10h, 20h and 30h TBC is best illustrated by sorting the pressure values during the operation, see Figure 11. The OEE is calculated by measuring the process availability and utilization during a defined time interval. The OEE for 10h calibration intervals was calculated at 68.6 %, 66.9 % for the 20 h calibration interval and 65.3 % for the 30 h calibration interval. Having an active control on the crusher can increase the performance of the circuit even more. For hydrocone crushers the mantle position can be adjusted during operation thereby further decreasing the need for calibrations. The crusher will however still need calibration to avoid violation of boundary conditions for the minimum allowed CSS, but not as often. The OEE for 30 hour calibration intervals with active control was calculated at 71.4 %, see Figure 11. The product quality is set to 100 %.

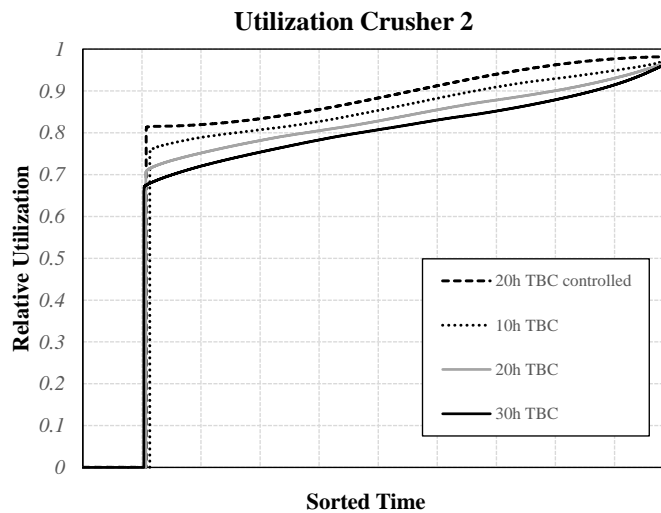

Figure 11. The difference in the crusher’s utilization if calibrated with 10, 20, 30 hour intervals or with 20 hour intervals while operating at a constant load.

Frequent calibrations will keep the crusher at a higher but more stable load. Infrequent calibration will however increase the pressure distribution within the crusher chamber. Adjusting the crusher during operation will maintain a stable operation until minimum CSS is detected by the system. Highest efficiency is achieved with a balance between wear, adjustments and calibrations.

5. Conclusions

This paper has shown a systematic approach to evaluating production performance with simulations over a long time perspective, taking into consideration adjustments, calibrations, failures and maintenance strategies. Process performance will change during operation due to wear and changes in the composition of the incoming feed. If left unattended the performance will diminish. To compensate for wear production units need to be maintained, calibrated and adjusted. However, during each stop the process performance is reduced, since the process is not producing a product during that period, calibrating the process regularly will however reduce pressure variation and increase the performance of the process. Adjusting the process continuously can have major benefits when it comes to the process availability and utilization, increasing performance by 4.1-9.3 % in these cases. The selection between preventive and corrective maintenance is balance of cost. Changing a wear part prematurely involves increased cost for the production since the part may have longer operational time left however, with more

controlled DT. Waiting until the parts are worn or broken can drastically reduce the productivity of the plant. Cost of changing a wear part is reduced but the cost of lost production is increased. Plant operators need to be attentive to the condition of the process and prepared for sudden failure. A detailed estimation of the different costs during the operation will be included in the future work.

6. Acknowledgment

This work has been performed within the Sustainable Production Initiative and the Production Area of Advance at Chalmers; this support is gratefully acknowledged. The authors wish to thank the Hesselman Foundation for Scientific Research, the Swedish national minerals and aggregate research program MinBaS (Minerals, Ballast, and dimensional Stone) and the construction industry's organisation for research and development (SBUF) for its financial support.

Reference

- Airikka, P., 2013. Plant-wide process control design for crushing and screening processes, Procemin 2013, Santiago, Chile.
- Asbjörnsson, G., Hulthén, E., Evertsson, M., 2012. Modelling and Dynamis Simulation of Gradual Performance Deterioration of a Crushing Plant - Including Time Dependance and Wear. *Minerals Engineering* 33, 13-19.
- Banks, J., Carson, J.S., Nelsson, B.L., Nicol, D.M., 2010. *Discrete-event system simulation*, 5. ed. ed. Upper Saddle River, N.J.
- Bevilacqua, M., Braglia, M., 2000. The Analytic Hierarchy Process Applied to Maintenance Strategy Selection. *Reliability Engineering and System Safety* 70, 71-83.
- Evertsson, M., 2000. *Cone Crusher Performance*, Department of Machine and Vehicle Design. Chalmers University of Technology.
- Evertsson, M., Bengtsson, M., Hulthén, E., Quist, J., 2014. Control Systems for Improvement of Cone Crusher Yield and Operation, *Comminution 14*, Cape Town, South Africa.
- Evertsson, M., Lindqvist, M., 2002. Pressure Distribution and Power Draw in Cone Crushers, *Minerals Engineering '02*, Perth, Australia.
- Hashemi, A.S., Sattarvand, J., 2014. Application of Arena Simulation Software for Evaluation of Open Pit Mining Transport Systems - A Case Study, 12th International Symposium Continuous Surface Mining, Aachen, Germany.
- Herbst, J.A., Mular, M.A., Pate, W.T., Song, M., 2012. The next step in minerals processing plant dynamic simulation to achieve the necessary standard for prefeasibility and feasibility studies - Modelling with discrete event for maintenance combined with accurate continuous process modelling, XXVI International Mineral Processing Congress, New Delhi, India.
- Hulthén, E., Asbjörnsson, G., Evertsson, M., 2012. Tuning of real-time algorithm for crushing plants using a dynamic crushing plant simulator, *Comminution '12*, Cape town, South Africa.
- Itävuori, P., Väyrynen, T., Vilkkö, M., Jaatinen, A., 2014. Tight feed-hopper level control in cone crushers, XXVII International Mineral Processing Congress, Santiago, Chile.
- Jonas, R.K., 2004. Design and Training Improvements Through the Use of Dynamic Simulation, *Light Metals 2004*.
- Kenne, J.P., Nkenungoue, L.J., 2008. Simultaneous control of production, preventive and corrective maintenance rates of failure-prone manufacturing system. *Applied Numerical Mathematics* 58, 180-194.
- Kullh, A., Älmegran, J., 2013. Efficiency and Productivity Tool to Measure and Monitor OEE and Process Pain, Product and Production development. Chalmers University of Technology.
- Lee, E., Evertsson, M., 2011. A Comparative Study Between Cone Crusher and Theoretical Optimal Crushing Sequences. *Minerals Engineering* 24, 188-194.
- Lindqvist, M., Evertsson, M., Chenje, T., Radziszewski, P., 2006. Influence of particle size on wear rate in compressive crushing. *Minerals Engineering* 19.
- Ljung, L., Glad, T., 2002. *Modelling of Dynamic Systems*. Prentice Hall Information.

- Powell, M.S., Benzer, H., Mainza, A.N., Evertsson, C.M., Taveres, L.M., Potgieter, M., Davis, B., Plint, N., Rule, C., 2011. Transforming the Effectiveness of a HPGR Circuit at Anglo Platinum Mogalakwena, SAG.
- Powell, M.S., Hilden, M.M., Evertsson, M., Asbjörnsson, G., Benzer, A.H., Mainza, A.N., Tavares, L.M., Davis, B., Plint, N., Rule, C., 2012. Optimisation Opportunities for HPGR Circuits, 11th AusIMM Mill Operators' 2012, Hobart, Tasmania
- Quist, J., Evertsson, M., 2010. Application of Discrete Element Method for Simulating Feeding Conditions and Size Reduction in Cone Crushers, XXV International Mineral Processing Congress 2010, Brisbane, Australia.
- Reynolds, B., 2010. Dynamic Simulation of an Alumina Refinery, XXV International Minerals Processing Congress, Brisbane, Australia.
- Salama, A., Greberg, J., Schunnesson, H., 2015. The Use of Discret Event Simulation for Underground Haulage Mining Equipment Selection. International Journal of Mining and Minerals Engineering 5.
- Sbárbaro, D., 2005. Control of Crushing Circuit with Variable Speed Drives, 16th IFAC World Congress, Prague, Czech Republic.
- Stafhammar, M.S., 2002. Screening of Crushed Rock Material, Department of Machine and Vehicle Systems. Chalmers University of Technology.
- Svedensten, P., 2005. Crushing Plant Performance, Applied Mechanics. Chalmers University of Technology, Göteborg.
- Svedensten, P., Evertsson, M., 2005. Crushing Plant Optimization by a Means of a Genetic Evolutionary Algorithm. Minerals Engineering 18, 473-479.
- Åström, K., 1995. PID controllers: Theory, Design and Tuning.

MODEL OF BANANA SCREEN FOR ROBUST PERFORMANCE

Asbjörnsson, G., Bengtsson, M., Hulthén, E. and Evertsson, C. M., Model of Banana Screen for Robust Performance, Presented at the 4th Physical Separation Symposium, Falmouth, UK, 11-12 June 2015, Submitted to Minerals Engineering (Journal), July 2015.

MODEL OF BANANA SCREEN FOR ROBUST PERFORMANCE

Gauti Asbjörnsson MSc, Magnus Bengtsson Ph D, Erik Hulthén Ph D, and Magnus Evertsson Ph D
Product and Production Development, Chalmers University of Technology, SE-412 96 Göteborg, Sweden
Email: magnus.bengtsson@chalmers.se

ABSTRACT

Screens are an important production unit in crushing plants. The performance of the screen is essential to the performance of the crushing plant. In this paper a mechanistic model of a banana screen is described and a novel model for screen deck configuration is presented. The developed model can be used for optimisation of a screen so that it has the best possible performance with respect to different feeding conditions, in order to obtain a desired separation. The simulation results were compared to full scale test data and the conclusions from this comparison is that the screen model needs further parameters to handle the necessary screen deck configuration. An initial static model was derived to explain how the screen deck configuration will affect the screen efficiency. The modification of the screen deck parameters resulted in a better correlation both regarding size distribution and predicted capacity.

1. INTRODUCTION

Screens are commonly used in both aggregate and mining industry with the purpose to separate and classify different products. The design of the screen varies depending on application and the setting of the screen may vary during its life time. It is often the case that settings of a screen need to be adjust, e.g. change aperture size or shape. Traditionally empirical studies can give some guidance how to change settings but in most cases there will be a risk of ending up with time consuming testing. In order to minimize this risk and to better reach an optimal setting mathematical model can be used. There are a wide range of screen models and it reaches from pure experimental models to fully mechanistic models. This paper continues the modelling work from Monica Solding Stafhammar [1]. The model is classified as a semi mechanistic model since it is based on mechanistic principles and also have some parameters that is based on experiments. The mechanistic part is based on the law of preservation and only the mass flow is modelled. The forces caused by the movement of the particle is not modelled e.g. as would be the case in DEM. The benefit of using a semi mechanistic model is that is fairly accurate when predicting both particle size distribution and capacity. It is also quite fast when it comes to computing; hence the model is suitable for optimizing screen settings.

The original version of the screen has shown to be quite slow to be suitable for optimisation, the reason for this is that the model originally was programmed to demonstrate the performance of the model and had a very high resolution in the representation of the particle size- The discrete incremental size was originally 0.01mm and this generated very large matrixes within the model. In the new version of the screen model the incremental size was increased to 1 mm. The modified screen model was validated against the original model and the change in resolution did not affect the model performance. The only disadvantage with using lower resolution is that the particle size distribution curve becomes more discontinuous since the simulated data between two points will be represented by straight lines. However this will be the same as when conducting sampling with laboratory sieving, i.e. the model becomes only valid for those fraction sizes one wishes to simulate. This model is as mentioned more efficient then earlier versions and even though the model only uses 2 stratification layers it has a very good performance compared to the original screen model. The reason for limiting the number of stratification layers is that in the simulations of screens with large angle of incline the bed thickness becomes so low that only on or perhaps two layers becomes active. The model is developed in Matlab/Simulink and can be implemented as an object in a larger program structure, the implementation has improved the performance a lot but the real change in the model is that the algorithm structure has been revised and made more efficient, e.g. redundant structures like time consuming for loops was rewritten. The generic approach used in the model makes it easy to configure the most commonly used screens within coarse comminution. Previous work on modelling banana screens has been conducted by Cleary et al. [2], where DEM was used to predict the performance of the screen.

There is however a need to investigate what parameters in a screen that will influence the performance of the screen. The aim with this paper is to present a novel way of determining how screen media properties can be modelled. And put into context of larger existing mechanistic models.

2. MODELLING THE BANANA SCREEN

The flow of material on the screen deck is modelled by introducing small discrete zones, see Figure 1. In order to model the mass flow the particle size distribution is divided in small sub fractions j , in every sub fraction all particles are assumed to be of equal size. Between the discrete zones mass is transferred as a mass flow. The mass flow is governed by Eq. (4).

Every zone i is divided into two layers (k), an upper and a lower layer. Between these layers material are also exchange through stratification. From the lower of these layers material can also pass through the screen apertures. The mass passing the aperture will be added to the zone below or added to the total mass passing all decks if there are no decks below the current one. Every zone contains only two layers and along the screen there will be numerous zones working in series, i.e. the mass flow moves from one zone to the next as a function of time. For each section there will be a set of zones. The approximated time step for good resolution is 0.01 s for each zone. Each zone has a bed thickness H , see Eq. (2). The zone moves with the velocity v shown in Eq. (1).

The major changes in the model are that only two layers are used, this increases the calculation speed. One aim of this model is to use in simulation and optimisation software's, it is therefore crucial to minimize the calculation speed.

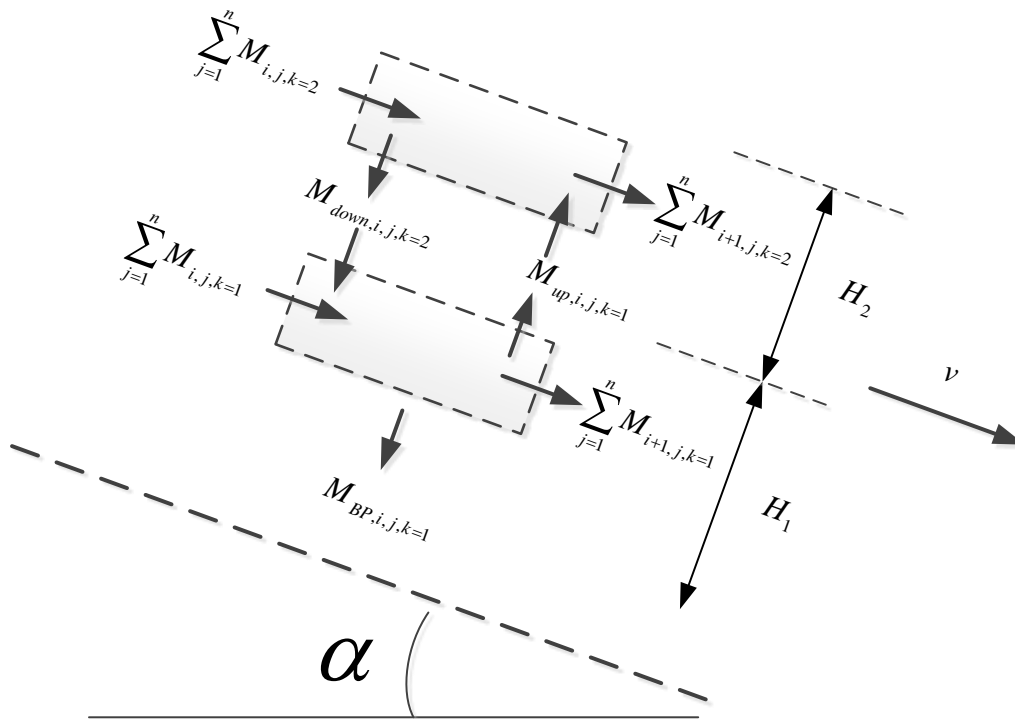

Figure 1 A schematic view of the equations that governs the mass flow in a screen.

As seen in Figure 2 there is an incline on the screen deck. The model is able to simulate a screen that has several panels with different inclines along a screen deck denoted α . The most common screen with this feature is the so called banana screen. The input to the model is the angle α for every screen cloth or section. In the model the incline of the screen will change the transport velocity of the rock material. Since a higher velocity will make the layers thinner it will also change the stratification and the passage through the screen decks. A principal view of the mass flow simulated by the model is shown in Figure 2.

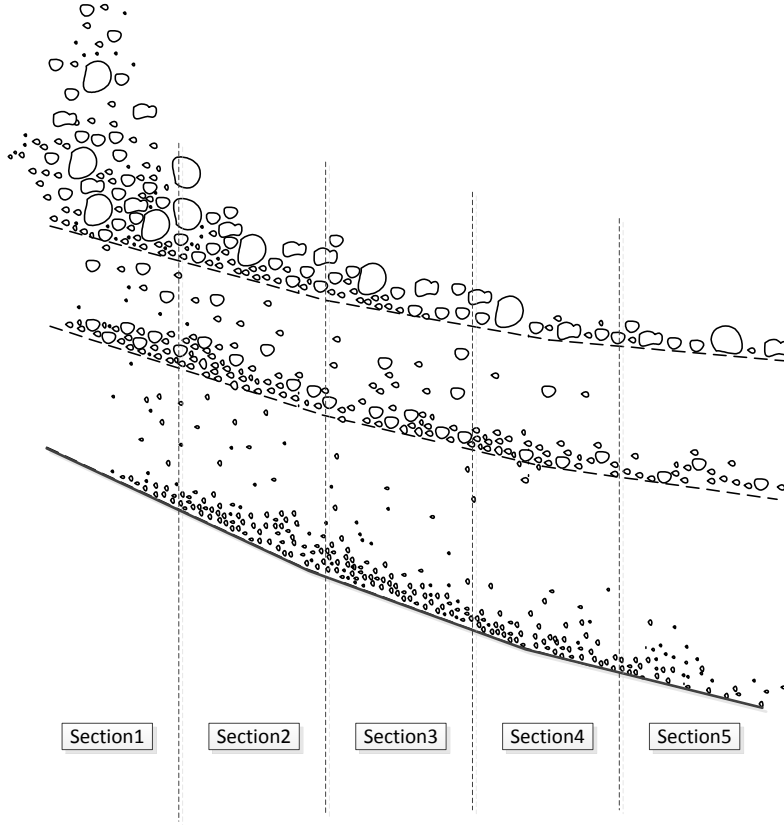

Figure 2 An example of how and what type of screen the model can simulate

$$v = (0.064\alpha + 0.2)(380R - 0.18)(0.095f\alpha^{(-0.5)} + 0.018\alpha - 0.38) \quad (1)$$

$$H_k = \frac{M_{i,j,k}}{Wv\rho} \quad (2)$$

$$M_{i+1,j,2} = M_{i,j,2} - M_{down,i,j,2} + M_{up,i,j,1} \quad (3)$$

$$M_{i+1,j,1} = M_{i,j,1} + M_{down,i,j,2} - M_{up,i,j,1} - M_{BP,i,j}k_j\Delta t \quad (4)$$

$$k_{a,j} = 11.5e^{-5.1(d_j/a_{ap})^3} \quad (5)$$

$$k_{b,j} = 1.5(d_j/a_{ap})e^{(d_j/a_{ap})^{15}} \quad (6)$$

$$k_j = k_{a,j}(a_{max}/g - 0.4)^{0.6} e^{-k_{b,j}(a_{max}/g - 0.4)^{0.5}} ; a_{max} \geq 0.4g \quad (7)$$

In a comparison between a screen with only one angle of incline in this paper referred to as a reference screen (with constant angle of incline set to 15 degrees) and a banana screen it can be shown that the screening efficiency is higher for the banana screen. In Figure 3 a principal comparison is shown between the mentioned screen configurations. The reason for choosing the latter configuration becomes evident when looking at the comparison shown in Figure 3, however the use of different screen media and aperture shape may in reality result in other outcome. The Figure 3 shows the cumulative flow rate for a specific fraction, this representation was also used in the work by [1] and may seem confusing at first glance but as a fraction becomes more and more separated it will eventually stop flowing through the screen and the asymptotic value will represent the actual capacity for that specific fraction. This plot is a good measurement in proving if the screen is configured properly, e.g. if a short screen where to be chosen the mass flow rate would not be converging to a horizontal asymptotic value. There are also cases where some fractions may be difficult to separate and this can also be seen with these type of figures.

It is a common fact that the banana screen increases the passage rate of fine fractions and the screening model makes it possible to simulate the behaviour in a certain screen. The down side with an increase in passage of material is that the local wear on the screen cloth increases. In a macroscopic perspective this model provides a good understanding of the fundamental functions in a real operating screen in the sense that the model can simulate the degree of separation along the screen deck depending on how the screen is configured and the screen is fed.

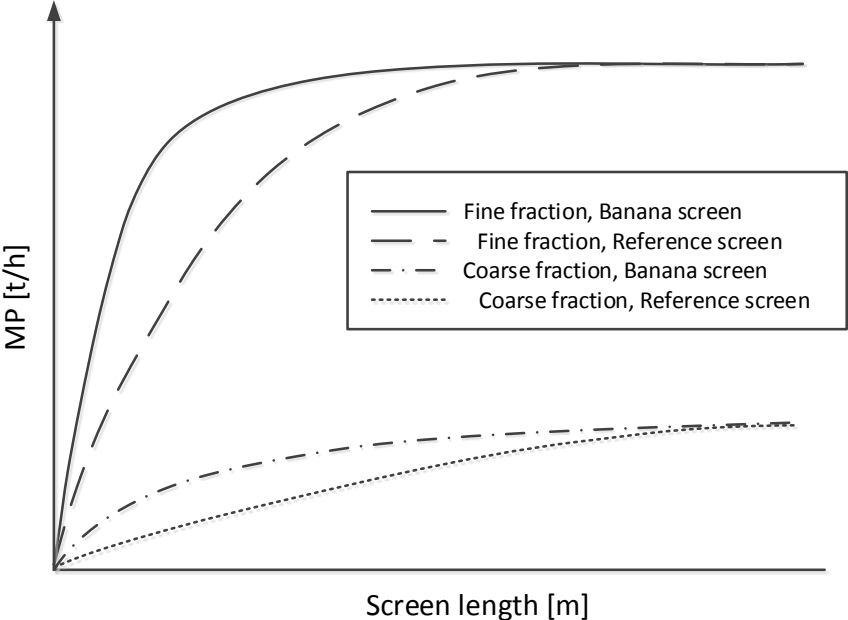

Figure 3 Mass rate passing (MP) of a banana screen (solid) compared with the reference screen (dashed).

3. METHODOLOGY

In this paper we have divided the experimental parts in two sections and included a modelling section following these parts. The reason for doing this is that the initial screen model used in this experiment was originally design for aggregate production where screens with fixed incline and steel screen media is used. The modelling of a banana screen with rubber or polyurethane media stretches the boundaries for the original model and therefore the initial experiment aims to show how the original model performs without changing any empirical parameters. The result from that experiment in combination from earlier research showed the need for additional modelling and the final experiment shows the impact of the updated model.

4. EXPERIMENTAL SETUP

Full scale validation with survey data from Anglo Gold Ashanti’s mine Sunrise Dam have been carried out. A survey was performed at Sunrise Dam at the coarse crushing section and at the mill section in March 2014. The screen in the coarse section is a Schenck SLD-3676 Double Deck Banana Screen. In Figure 4 the sample data from the survey, for the screen feed and product is illustrated. Blue, red and magenta lines are the three screen products; the green curve is the measured feed curve from before the screen while the black curve is calculated from the three screening products to ensure mass balance.

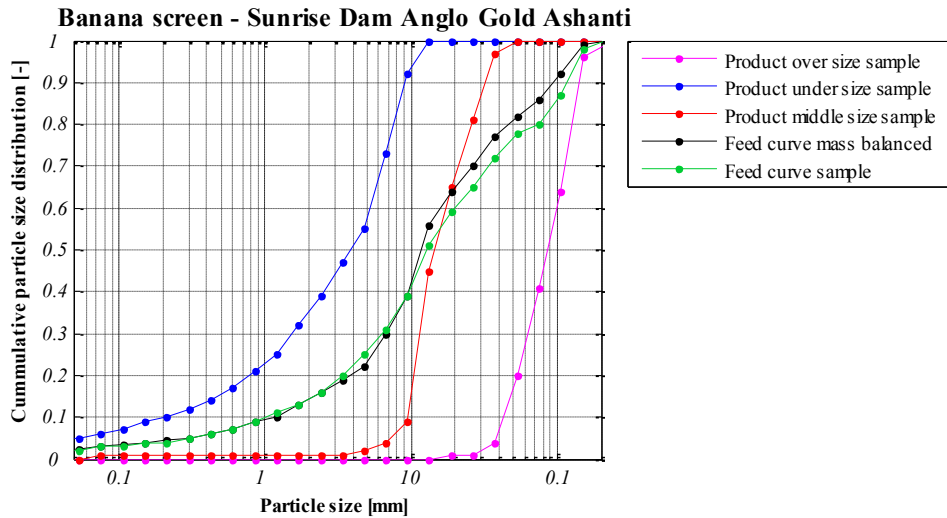

Figure 4 Particle size distribution of the samples taken from Anglo Gold Ashanti at Sunrise Dam.

4.1. Simulation setup

The input parameters for the example simulation demonstrated in this report are shown in Table 1 – 3. The Media in the banana screen is Polyurethane however the original screen model is only validated for steel media so the initial setup will not have a parameter for changing media. The original screen model was also validated for screen slopes between 10-20 degrees and this may also affect the performance of the model.

Table 1: Screen configuration

parameter	value
Number of decks	2
Number of sections	5
Frequency	18.3 Hz
Throw	9 mm
Width	3.6 m
Length	7.3 m
Media	Polyurethane

Table 2: Deck slope angle

Deck	Section 1	Section 2	Section 3	Section 4	Section 5
Deck 1	28	23	18	13	8
Deck 2	29	25	21	17	13

Table 3: Deck aperture

Deck	Section 1	Section 2	Section 3	Section 4	Section 5
Deck 1	40	40	40	40	40
Deck 2	10	10	10	12	12

5. RESULTS FROM FIRST EVALUATION

In the first evaluation of the screen model the simulated product had a lower top size for all simulated products. The reason for this discrepancy is that the model has a strict definition of aperture size which means that if the aperture is set to e.g. 40 mm in the model there will be a larger aperture value in the real screen. And the screen model also assumes that the particle shape is fairly cubical, which is not always the case. The first comparison is shown in Figure 5. In the case with the banana screen the screen deck was also consistent of Polyurethane and it had also rectangular apertures. So with this in consideration the model needed an adjustment to better handle these conditions.

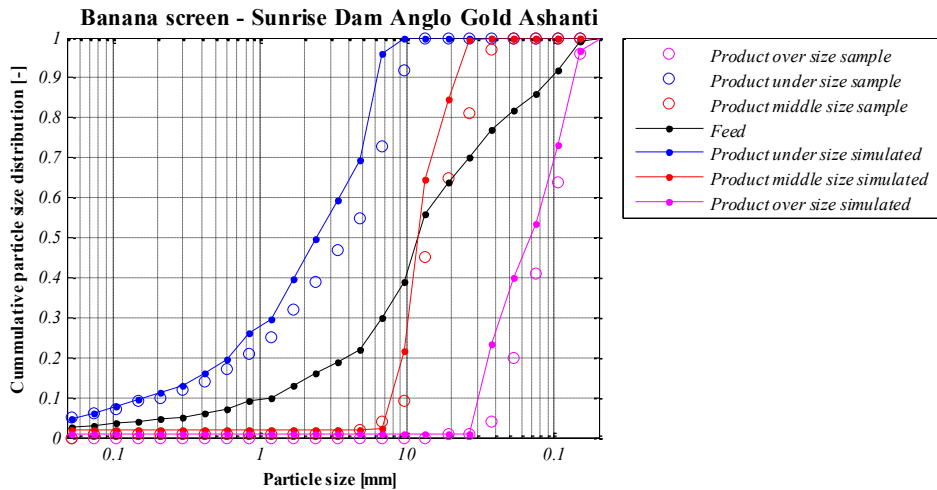

Figure 5 Particle size distribution of the sample (circles) and simulated particle size distribution (lines).

With the aid of efficiency curves the performance of both screen and model can be evaluated. The aim with this comparison is partially to see how well the actual screen configuration can achieve a desired product distribution and it also gives an indication how well the model can predict this hence be useful for configure screens from a design perspective. In Figure 6 the comparison shows that there is a discrepancy between model and measured data.

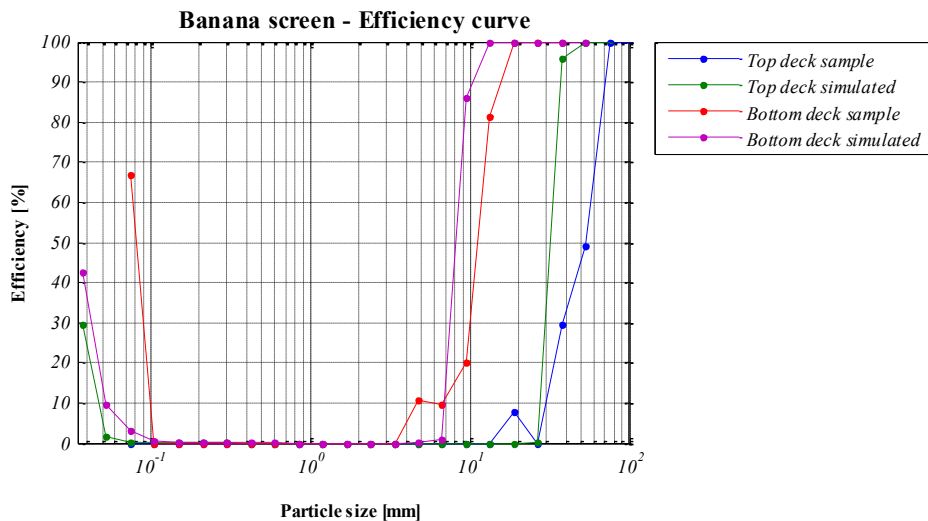

Figure 6 The efficiency curve for the top and bottom deck for both the sample and simulated results.

As stated earlier the banana screen had a deck configuration that was somewhat different from the initial validated screen model. The original screen model was validated for screens with steel decks and quadratic apertures. So the model need to be adapted and developed further to handle other types of screen decks. For the full scale tests conducted on the banana screen the screen deck configuration is shown in Figure 7 and table 4. By estimating a correction factor for rectangular slots the models aperture size was increased by 30% of the smaller aperture of each slot, the corrected aperture sizes are shown in Table 5. In section 6 an initial investigation is done to elaborate on how this correction factor can be estimated.

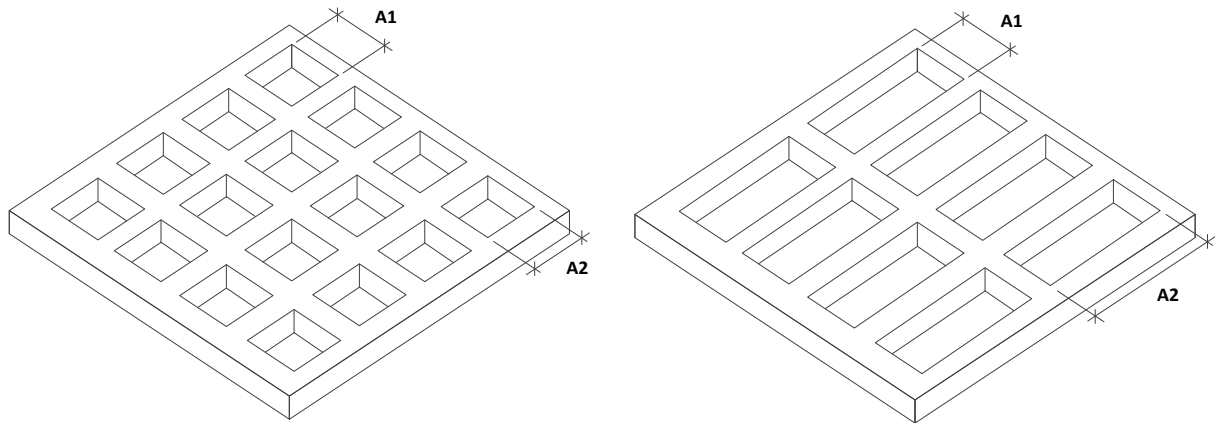

Figure 7 The difference between squared aperture and rectangular slots.

Table 4: Actual deck aperture

	Section 1	Section 2	Section 3	Section 4	Section 5
Deck 1	40x100	40x100	40x100	40x40	40x40
Deck 2	10x35	10x35	10x35	12x50	12x50

Table 5: Estimated deck aperture

	Section 1	Section 2	Section 3	Section 4	Section 5
Deck 1	52	52	52	40	40
Deck 2	13	13	13	16	16

6. RESULTS FROM SECOND EVALUATION

A better fit was achieved by increasing the theoretical aperture size of the deck by 30 % compared to previous configuration, see Figure 9 and Figure 10. It can be noted that the efficiency curve has a better correlation between measured and simulated data.

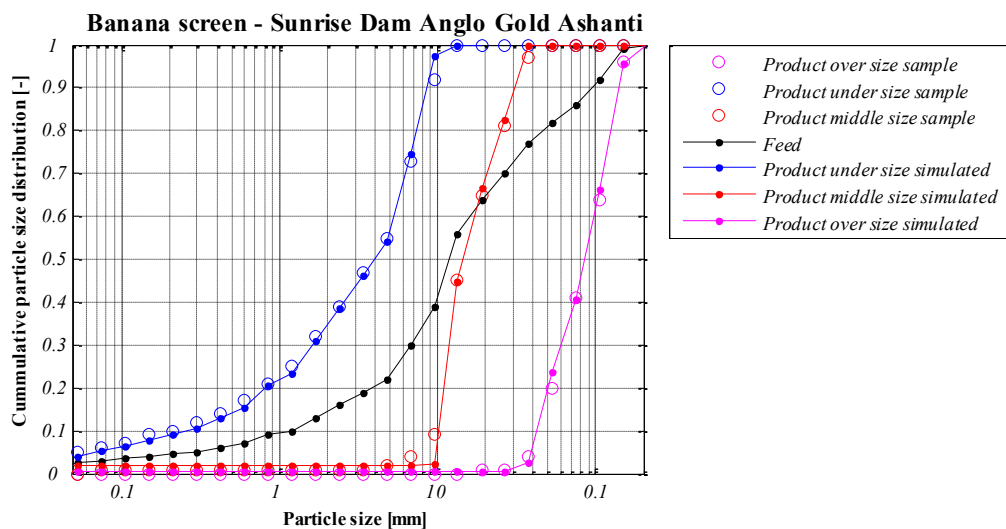

Figure 8 Particle size distribution of the sample (circles) and simulated particle size distribution (lines).

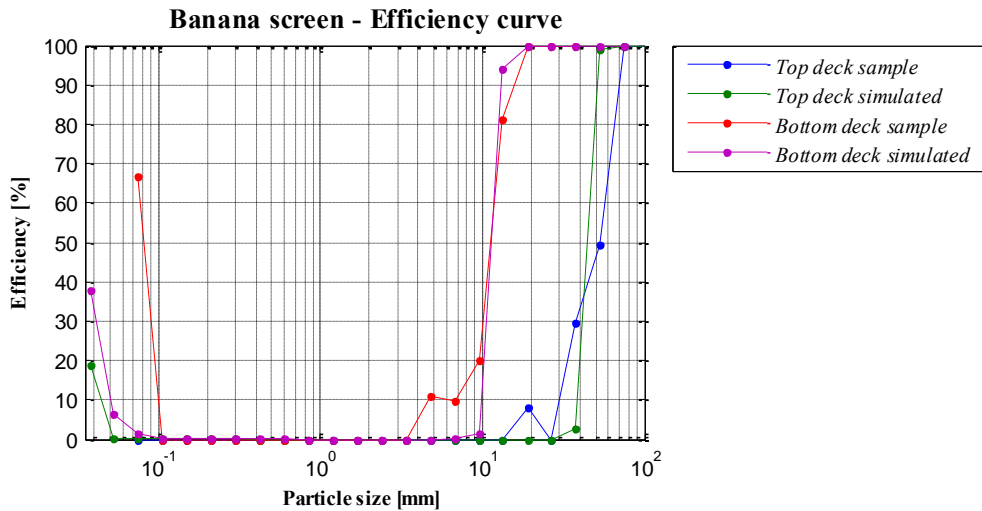

Figure 9 The efficiency curve for the top and bottom deck. For both the sample and the simulated results.

In order to understand how the geometry of the screen deck affects the screening a performance an initial analysis of the geometry need to done since it is not likely that the assumed value of 1.3 for the correction factor will always be true.

7. MODELLING RECTANGULAR APERTURE

In the previous chapters it was concluded that the original model was limited to fully predict the outcome when the screen deck configuration changed dramatically. In order to improve the model in the future an additional model has been derived that more adequately can describe how the screen deck geometry will affect the screen performance. In Figure 10 the width of the aperture is denoted f and the length of the aperture is denoted b . The thickness of the screen deck is denoted c and the thickness of the ribs is denoted a .

In the work by Bengtsson and Hulthén [3] there where tests made on different screen media to determine how the passage rate will be affected. The result from that report concluded that the open screen area have a dominating effect on the passage rate. In the work by [1] the mass flow through the screen deck as a function of an imperial passage parameter k is defined. This passage parameter is shown in Eq. (7). As can be seen the passage parameter is a function of average fraction size d , particle acceleration a_{max} and gravity constant g .

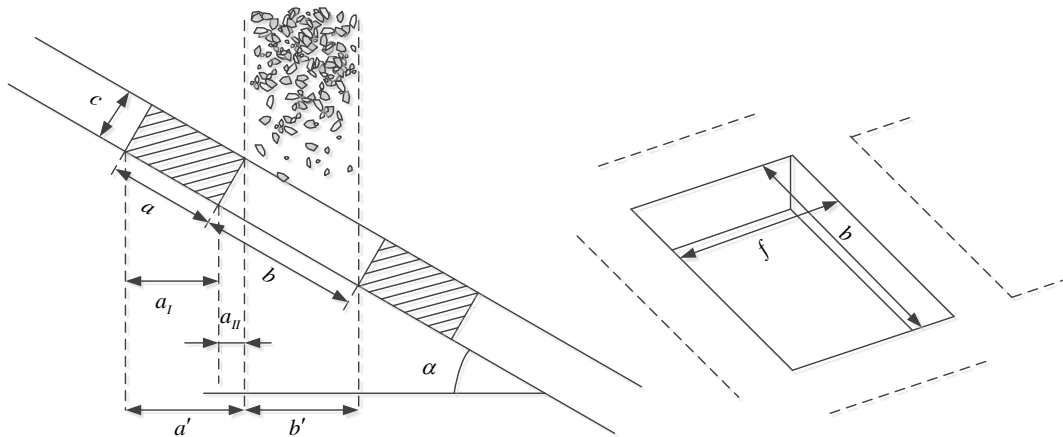

Figure 10 Geometry of the screen deck will affect the open area hence the mass flow through the screen.

By analyzing the geometry of the screen deck a relationship can be established that describes how the open area will depend on the given parameters in the geometry. In the general case the open area is calculated in Eq. (8). Since the original screen model was validated for screen decks consisting of steel and with quadratic aperture the open area for the original model need to be determined in Eq. (9). The use of rectangular aperture will affect the maximum particle size of particles passing the screen deck. Since the original passage parameter is calibrated for an open area of a steel wire screen cloth the aperture is only valid for steel screens. An expression for how the passage rate depends on the geometry of the screen cloth is shown in Eq. (10). The value η represents the quote between arbitrary deck geometry and the original open area for steel screens. Since the original screen model does not address the open area as a parameter there must be a relative perspective regarding how the average aperture should be estimated since it affects the probability of particles passing the screen deck. In Eq. (11) the geometry corrected aperture is defined. The geometry defined aperture value shown in Eq. (5) and (6) will replace the original aperture value in Eq. (12) and (13).

$$\gamma' = \frac{(b \cos \alpha - c \sin \alpha) f}{(a + b)(a + f) \cos \alpha} \quad (8)$$

$$\gamma'_{steel} = \frac{(b_{steel} \cos \alpha - c_{steel} \sin \alpha) f}{(a_{steel} + b_{steel})(a_{steel} + f_{steel}) \cos \alpha} \quad (9)$$

$$\eta = \frac{\gamma' \sqrt{(b^2 + f^2)}}{\gamma'_{steel} \sqrt{(b_{steel}^2 + f_{steel}^2)}} \quad (10)$$

$$a_{cap} = \eta a_{ap} \quad (11)$$

$$k_{ca,j} = 11.5 e^{-5.1(d_j/a_{cap})^3} \quad (12)$$

$$k_{cb,j} = 1.5(d_j/a_{cap}) e^{(d_j/a_{cap})^{15}} \quad (13)$$

The estimate of η described in chapter 5 can be calculated as a function of the slope of the screen deck. The initial estimate of η of 30% that was made in chapter 5 seem to correlate with the predicted η . Figure 9 shows how the η depends on the angle of incline. By studying Figure 8 it can be shown that e.g. an increase in angle in combination with increased deck thickness will affect the open area negatively. So since the Eq. (10) is a function of both angle of incline and screen deck geometry the open area will change dramatically in the case of the banana screen. As can be seen in the table 4 in the first section a rectangular aperture is used, and the Eq. (10) reveals the reason why the screen is configured in this manner. An example if a quadratic aperture with the diameter 40 mm was used instead the open area would decrease dramatically and particles in that size range would be hitting on inside of the aperture in such a way that it would increase the risk of bouncing upwards instead of passing through.

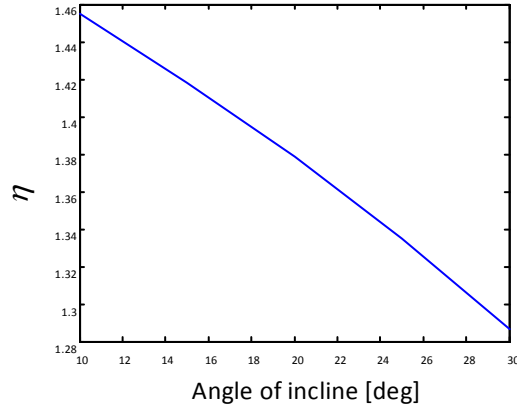

Figure 11 η as a function of slope angle.

In order to evaluate Eq. (10) a new aperture table was calculated with the calculated η see Table 6 and 7.

Table 6. Calculated η

	Section 1	Section 2	Section 3	Section 4	Section 5
Deck 1	1.3	1.35	1.39	0.62	0.64
Deck 2	0.9	1.04	1.17	1.25	1.39

Table 6. Calculated deck aperture

	Section 1	Section 2	Section 3	Section 4	Section 5
Deck 1	52	54	56	25	26
Deck 2	9	10	12	15	17

In

Figure 12 the result from the simulation is shown. As can be seen in table 6 the η value varies and most interesting is the fact that the 2 last sections on the upper deck has remarkably low open area. In this application the these two sections has quadratic apertures and in the simulation these two show that there still is a separation and due to the low value on that angle of incline the residence time in these sections become longer which gives more time for the final separation, i.e. the increased residence time is a consequence of decreased velocity, see Eq. (1) .

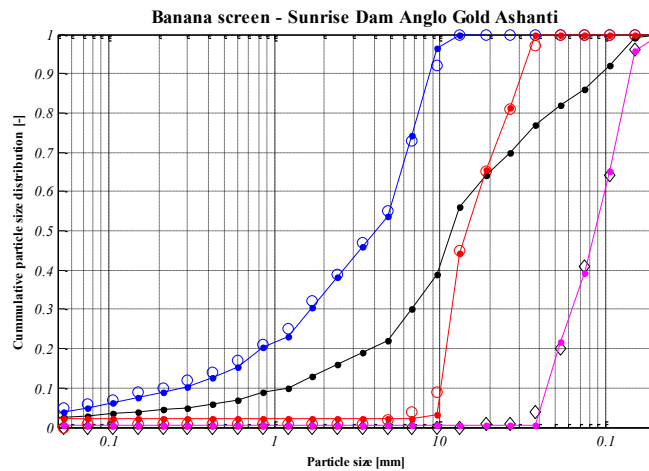

Figure 12 Final result from the simulation with the η as a function of angle of incline and screen deck geometry.

8. DISCUSSION

The contributions have been a more precise flow model for screens in general and for banana screens in particular. A good fit was established with a theoretical aperture size from rectangular slot apertures, enabling a larger top size of the material that falls through the deck.

9. CONCLUSIONS

The first attempt on validating the screen model against survey data showed fairly good correlation with measured data; however the screen model has no parameter for handling the shape of the aperture hole which suggests further investigation on possible model improvements. The original representation of the aperture size has been successfully updated so that the aperture geometry for arbitrary rectangular geometries can be modelled.

10. FUTURE WORK

The result from the initial evaluation and the additional screen deck model presented in the paper raises question on what phenomenon there are that affects the mass flow through the screen, Future work will focus on setting up a DEM simulation that will use the model parameters defined in chapter 6. The advantage of DEM is that the mechanistic approach will increase the resolution of the screen model and will also in a controlled manner simulate a range of conditions that might take time to setup in a real experiment in a laboratory.

11. ACKNOWLEDGMENTS

The authors would like to thank Amira P9P sponsors and especially the persons involved in the survey at Sunrise Dam and the responsible personnel at Anglo Gold Ashanti's mine Sunrise Dam.

12. NOMENCLATURE

$M_{i,j,k}$	Mass flow from one element	$\left[\frac{kg}{s} \right]$
M_{up}	Mass flow upwards between layers	$\left[\frac{kg}{s} \right]$
M_{down}	Mass flow downwards between layers	$\left[\frac{kg}{s} \right]$
M_{BP}	Mass flow through the screen deck	$\left[\frac{kg}{s} \right]$
k	Passage parameter	$\left[\frac{1}{s} \right]$
a_{max}	Acceleration	$\left[\frac{m}{s^2} \right]$
g	Standard acceleration due to gravity	$\left[\frac{m}{s^2} \right]$
a_{ap}	Aperture diameter	$[m]$
d_j	Particle diameter	$[m]$
α	Angle of incline	$[deg]$
R	Throw	$[m]$
f	Frequency	$[Hz]$
H	Bed thickness layer k	$[m]$

13. REFERENCES

- [1] Soldinger Stafhammar M. Screening of Crushed Rock Material: Institutionen för maskin- och fordonssystem, Chalmers tekniska högskola,; 2002.
- [2] Cleary PW, Sinnott MD, Morrison RD. Separation performance of double deck banana screens – Part 1: Flow and separation for different accelerations. *Minerals Engineering* 2009;22:1218-29.
- [3] Bengtsson M, Hulthén E. Passage parametrar vid siktning 2004.
- [4] Li J, Webb C, Pandiella SS, Campbell GM. Discrete particle motion on sieves—a numerical study using the DEM simulation. *Powder Technology* 2003;133:190-202.
- [5] Soldinger M. Influence of particle size and bed thickness on the screening process. *Minerals Engineering* 2000;13:297-312.
- [6] Soldinger M. Transport velocity of a crushed rock material bed on a screen. *Minerals Engineering* 2002;15:7-17.
- [7] Soldinger M. Interrelation of stratification and passage in the screening process. *Minerals Engineering* 1999;12:497-516.

