



Politecnico di Torino

## Porto Institutional Repository

[Proceeding] INNOVATIVE ELECTRIC POWER SUPPLY SYSTEM FOR NANO-SATELLITES

*Original Citation:*

Anwar Ali; M. Rizwan Mughal; Haider Ali; Leonardo M. Reyneri (2013). *INNOVATIVE ELECTRIC POWER SUPPLY SYSTEM FOR NANO-SATELLITES*. In: International Astronautical Congress, Beijing. pp. 1-7

*Availability:*

This version is available at : <http://porto.polito.it/2530690/> since: February 2014

*Publisher:*

International Astronautical Federation (IAF)

*Terms of use:*

This article is made available under terms and conditions applicable to Open Access Policy Article ("Public - All rights reserved") , as described at [http://porto.polito.it/terms\\_and\\_conditions.html](http://porto.polito.it/terms_and_conditions.html)

Porto, the institutional repository of the Politecnico di Torino, is provided by the University Library and the IT-Services. The aim is to enable open access to all the world. Please [share with us](#) how this access benefits you. Your story matters.

(Article begins on next page)

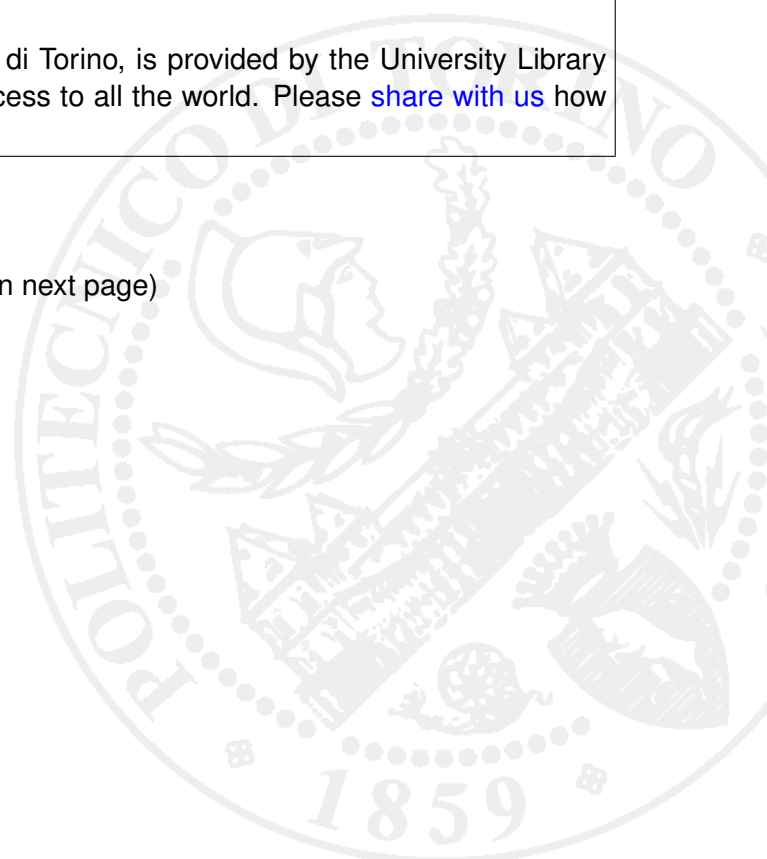

IAC-13,C3.4,5x19111

## INNOVATIVE ELECTRIC POWER SUPPLY SYSTEM FOR NANO-SATELLITES

**Anwar Ali**

Department of Electronics and Telecommunications, Politecnico di Torino, Torino, Italy. [anwar.ali@polito.it](mailto:anwar.ali@polito.it)

M. Rizwan Mughal, Haider Ali Leonardo M. Reyneri

**Abstract**—This paper discusses modular electric power system (EPS) unit for different size of nano-satellites. Energy harvesting, battery charging and voltage regulation units for different architectures have been analyzed and developed on a single tile. Power generation for nano-satellites is usually distributed over a number of solar panels. Solar panels consist of different number of solar cells connected in various (series, parallel & mixed) configurations may be prone to different types of faults. Simple fault tolerance analysis of different configurations of various numbers of solar cells has been done. Boost power converter required for specific amount of power has been designed and implemented. Normally power conversion, storage and management is concentrated in a single point. This is a typical point of failure. We have developed a modular distributed EPS which consists of a number of small modular power converter, storage and distribution subsystems on single tile for different architecture of nano-satellites. This reduces harness complexity, the overall mass and removes the single point of failure. Power budget and performance dependent on specific mission requirements and design have been analyzed.

### I. INTRODUCTION

Nano-satellite systems based on rad-hard components are most feasible for space environment. But the major problems with these components are their cost and unavailability in the market for the universities and SMEs (small and medium enterprises) [1]. This problem was solved due to the availability of COTS (Commercial Off The Shelf) components and already designed subsystems in the market. Nano-satellites design, development and operation are the major research areas for many Universities these days. The main objective of these projects is to train the researcher and students and to provide technical expertise to the companies working in this area. In this regard Department of Electronics and Telecommunications (DET) at Politecnico di Torino also started development of nano-satellites [2]. Many professors, researchers and students from different departments of Politecnico di Torino are involved in the development of these projects. They worked on various projects and developed nano-satellites of different sizes and standard. They developed their first nano-satellite called PiCPoT (Piccolo Cubo del Politecnico di Torino) with size 13cm×13cm×13cm and a mass of 2.5kg [3]. PiCPoT was intended to be launched together with other university satellites on July, 26, 2006, from Baykonour. Unfortunately a failure of the launcher has forced its destruction before being released on its orbit. After that DET started work on another project called AraMiS and developed nano-satellites of different sizes and shapes. ARAMIS general architecture has dimensions 16.5cm×16.5cm×16.5cm.

subsystem, attitude determination and control subsystem, telecommunication subsystem etc; all are

modular and developed on separates tiles which can be replaced separately without troubling the other subsystems.

The design process of AraMiS is based on tiles. Tiles or panel bodies are printed circuit board with solar panel on exterior side and other electronic subsystems on interior side. The feature of AraMiS design approach is its modularity. Utilizing the COTS approach, AraMiS extends modularity in two directions. First hardware modularity is achieved through utilizing individual blocks for each subsystem. Second software modularity is obtained by using separate coding for each subsystem. These modules can be reused for multiple missions which helps in significant reduction of the overall budget, development and testing time. One has just to reassemble the required subsystems to achieve the targeted specific mission. On the basis of AraMiS approach DET developed its third nano-satellite of CubeSat standard called AraMiS\_C1. It has dimensions equal to CubeSat 10cm×10cm×10cm and weight less than 1.33kg [4]. Fig.1 shows photographs of different dimensions nano-satellites developed by DET at Politecnico di Torino.

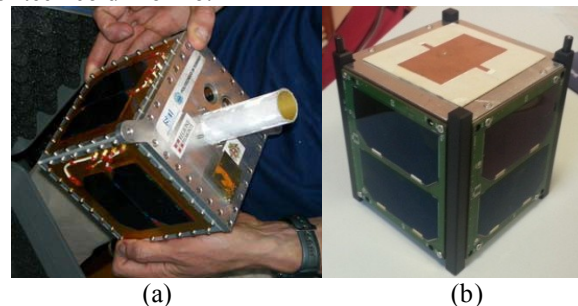

Fig. 1: Photographs of (a) PiCPoT (b) AraMiS\_C1 CubeSat standard

All the subsystems of these satellites have modular architecture based on tiles. Electric power supply Electric Power Supply (EPS) systems of the two architectures are also developed on separate power management tiles. Each power management tile has solar panels on the exterior face and all other electronics on the interior side. These tiles are of different sizes relative to specific satellite architecture. The solar panel side photographs of two types of power management tiles are shown in Fig. 2.

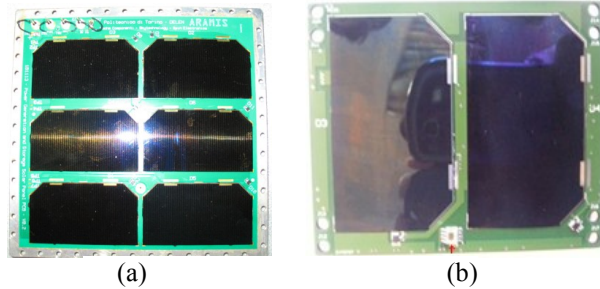

Fig. 2: Solar panel side view of the power management tiles for (a) PiCPoT (b) AraMiS\_C1 CubeSat standard

## II. SYSTEM DESCRIPTION

Electric Power Supply (EPS) system of AraMiS is responsible for power generation, optimization and control, conversion to different voltage levels and storage. Modular EPS are developed on various sizes of power management tiles for different AraMiS satellites. They have solar panels on the outer face and other electronics on the inner face. The main power sources are four or five solar panels mounted around the satellite. Each solar panel consists of different number of solar cells connect in series or in parallel depends on the power requirement of the specific AraMiS architecture. Solar cells of AraMiS are triple junction, GaAs and space qualified devices. A detailed Fault tolerance analysis was performed for different number of solar cells either connected in series, parallel or hybrid combination. The power generated by solar panels is normally either above or below the Power Distribution Bus (PDB) level. In case, if power generated by solar panels is below the PDB level, a boost converter is used to convert it to the PDB level, vice versa a buck converter is used. Suppose a specific number of solar cells generate power equal to the PDB level but still a system is required in between the solar panel output and PDB in order to operate the panels at their Maximum Power Point (PPT) which is called Maximum Power Point Tracker (MPPT) [5]. In AraMiS EPS, batteries are charged from PDB. In case of a simple boost or buck converter between solar panel and PDB, they just connect the solar panel module directly

to the battery. This forces solar panels to follow the battery voltage, which is not the suitable operating point and results in less efficient system. MPPT with boost or buck converter step up or step down the solar panel voltage to PDB level extracting maximum power from solar panel according to environmental conditions. Each of these converters has a particular MPPT made with an hysteretic switching power converter, designed with small number of required components. Bipolar devices are not sensitive to latch-up, therefore only bipolar devices were used in the implementation of EPS system. Redundancy is a key feature in the development of AraMiS EPS: there are four independent converters to allow the system to provide power to all the subsystem components of the satellite. If three or four of them get damaged, one is enough to provide power to the whole satellite, although with reduced performances. EPS of AraMiS uses different number of Ni-Cd batteries divided into various groups. Different linear and switching regulators are used to convert the PDB voltage to low voltage levels. Load switches at the input of each subsystem supply and cutoff power from the respective subsystem. Current, voltage and temperature sensors are employed at different points of the EPS for housekeeping purposes. Tile processor is used to perform the power management operations. Fig. 3 shows EPS block diagram of AraMiS\_C1.

### II.1 Solar Panel

Solar panel consists of triple junction GaAs solar cells with an efficiency of 26%. Each solar cell generates 2.2V. PiCPoT and AraMiS\_C1 projects solar panels have two solar cells connected in series while ARAMIS general architecture uses six solar cells on a single panel assembled on the outer surface of each Power Management Tile. Four solar panels are mounted on as many external faces of these projects. At a time a single or two solar panels will be exposed to the sun. When single solar panel is exposed to the sun, it will be at right angle and will generate the maximum power. In case two solar cells are exposed, they will be at 45° angle to the sun. There is a single pack of ten NiCd batteries store the extra power from all the four power management tiles. In case when two solar panels are generating at a time, batteries will be charged from both solar panels.

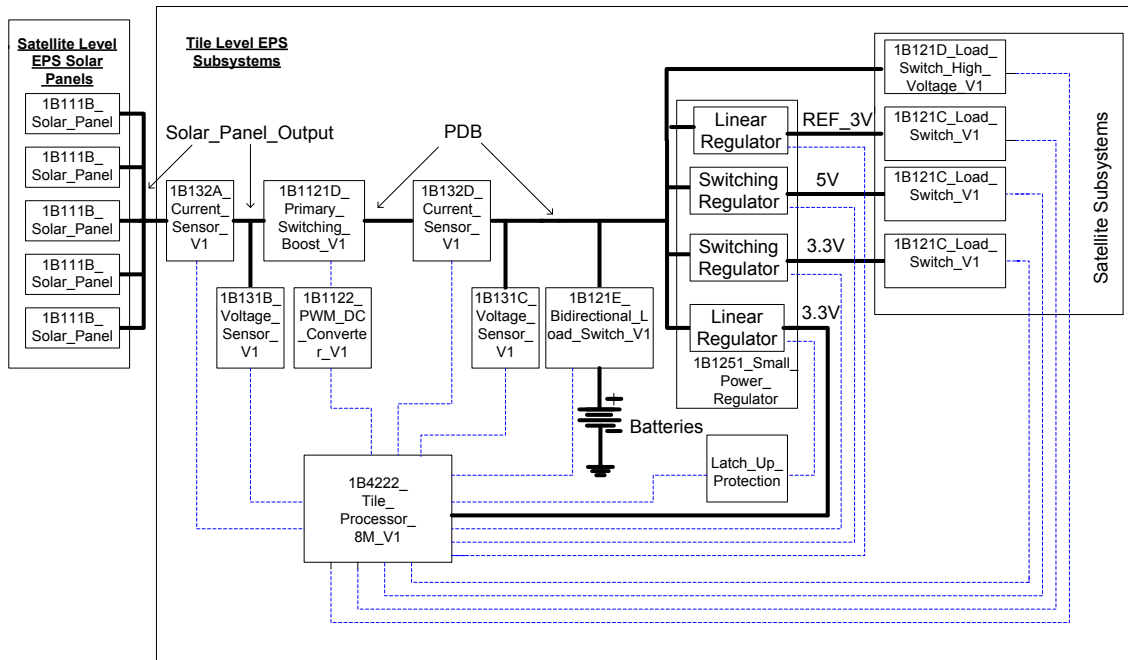

Fig. 3: EPS block diagram of AraMiS\_C1.

### II.II Solar Panel Fault Tolerance Analysis

Simple fault tolerance analyses have been performed for two series connected solar cells (PiCPoT and AraMiS\_C1) and six series connected solar cells (AraMiS general architecture). In this analysis, a case of short and open circuits of a single solar cell (single fault) is considered. The simulation circuit [6] of a single solar cell is shown in Fig. 4.

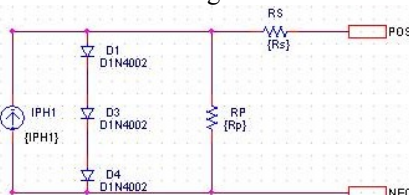
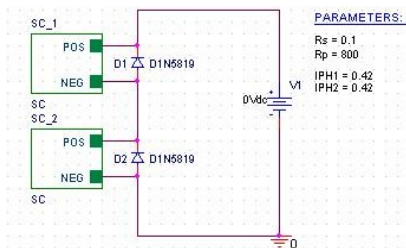
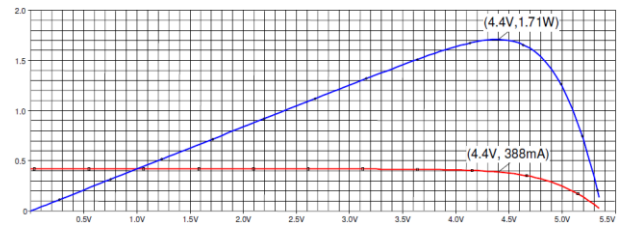

Fig. 4: Simulation circuit of a single solar cell.

In Fig. 4 IPH, RS and RP are solar current, series and parallel resistor parameters respectively. By changing the values of these parameters one can easily simulate solar cells with different behaviour.



(a)



(b)

Fig. 5: Two solar cells in series (a) schematic (b) plots of voltage, current and power

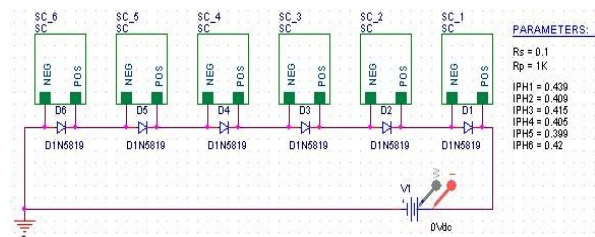

(a)

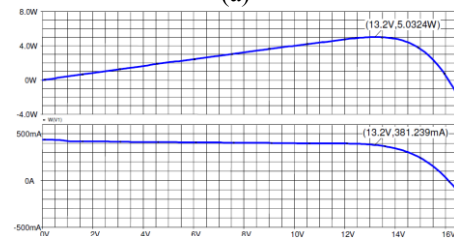

(b)

Fig. 6: Six solar cells in series (a) schematic (b) plots of voltage, current and power

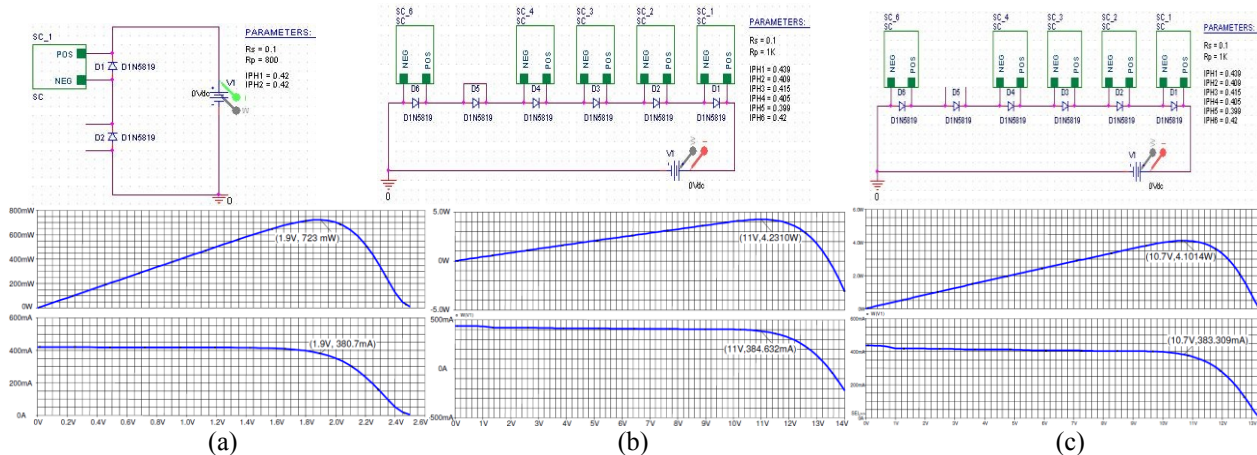

Fig. 7: Schematic and plots (output voltage, current and power) of (a) two series connected solar cells with one cell open circuit (b) six solar cells in series with one cell short circuit (c) six solar cells in series with one cell open circuit

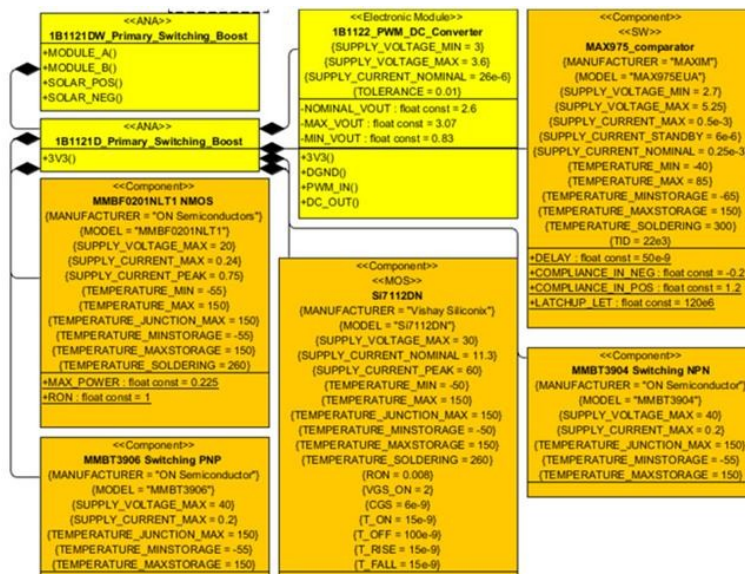

Fig. 8: UML class diagram of EPS AraMiS\_C1 boost converter

Fig. 5 and Fig. 6 shows output current, voltage and power waveforms for the solar panels of AraMiS\_C1, PiCPoT and AraMiS general architecture. The output voltage and current for two solar cells connected in series are 4.4V and 388mA while in case of six solar cells connected in series, output voltage and current are 13.2V and 381.2mA respectively at their maximum power point (MPP). In Fig. 7 schematic and plots are shown (output voltage, current and power) for two series connected solar cells with one cell open circuit and six solar cells in series with one cell short/open circuit respectively.

## II.II Switching Converters

Different switching converters have been designed and implemented for the EPS of AraMiS\_C1, PiCPoT and AraMiS general architecture, in order to convert the

solar panel voltage to PDB level. In case of EPS for AraMiS\_C1 and PiCPoT solar panel voltage is less than the PDB level, therefore a boost converter is used. While for AraMiS general architecture a buck converter is used. In order to get maximum power from the solar cells they should be operated at its maximum power point (MPP). Normally, MPP is not fixed and varies with environment conditions. For this variable MPP a boost converter along with Maximum Power Point Tracker (MPPT), operate the two solar panels at its maximum power point. Comparator hysteresis loop is used to get the maximum power from the series connections of the two solar cells. PWM\_DC\_Converter fixes the reference voltage for the comparator of boost converter. UML class diagram of AraMiS\_C1 boost converter is shown in Fig. 8.

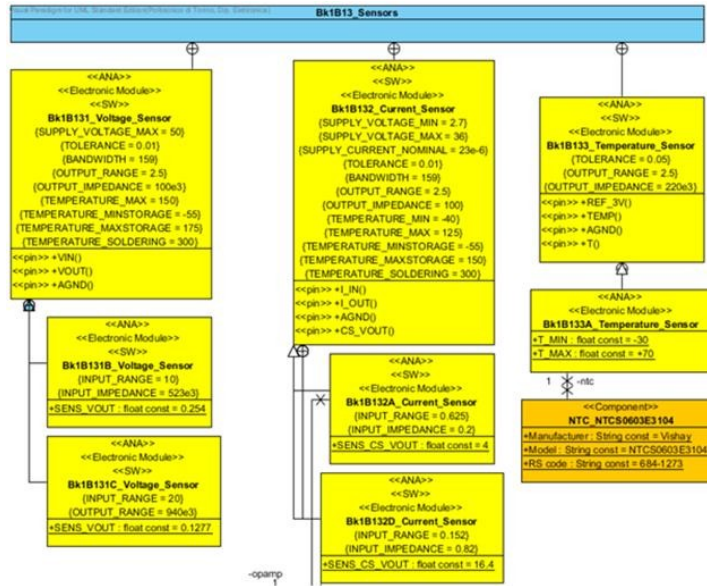

Fig. 9: UML class diagram of EPS AraMiS\_C1 housekeeping sensors

### II.III Housekeeping sensors

Housekeeping sensors keep the EPS within operations limits. There are two voltage, two current and one temperature sensor. Two voltage sensors with input voltage range of 10V and 20V monitors solar panel and PDB voltage levels respectively. Output voltage range of the voltage sensor is given by (1).

$$V_{OUTPUT\_RANGE} = SENS\_VOUT \times INPUT\_RANGE \quad (1)$$

In order to maintain the maximum current value within the operation limit of the EPS system, it also contains two current sensors. These sensors have input current ranges of 625mA and 152mA, mounted on output of solar panel and boost converter. Output current range of the current sensor is given by (2).

$$I_{OUTPUT\_RANGE} = SENS\_CS\_VOUT \times INPUT\_RANGE \quad (2)$$

EPS has one temperature sensor which is a glass protected NTC thermistor and has a temperature range from -30°C to 70°C. UML class diagram of EPS AraMiS\_C1 housekeeping sensors is shown in Fig. 9.

### II.IV Bidirectional Load Switch

Bidirectional switch is used to charge the batteries from power distribution bus (PDB) in presence of solar power while in absence of solar power, it is used to supply power to the PDB. Schematic of bidirectional switch is shown in Fig. 10.

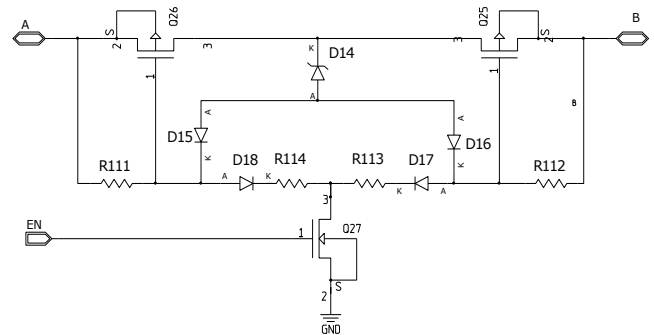

Fig. 10: Schematic of bidirectional switch

## III. ARAMIS-C1 POWER BUDGET

### III.I Power Sources

The only power source of AraMiS-C1 are the four solar panels, which cover as many faces of the satellite. Each solar panel is about 2×70×40mm<sup>2</sup> that is 5600mm<sup>2</sup>.

Sun power density at LEO is about 1362 W/m<sup>2</sup>, and the average persistence of satellite in the day is about 60%. By taking into account that only one or at most two panels are exposed at a time at sunlight.

- When one panel, it is perpendicular to sunlight and has an equivalent panel surface of 5600mm<sup>2</sup>, average power from sun is about 7.63W. Average efficiency of the solar cell is 26% which gives 1.98W power at output terminal.
- When two panels are 45° from sunlight, the total equivalent panel surface, taking into account their size and their average inclination is about 7840mm<sup>2</sup>. Optical power from the sun is 10.678W. Average efficiency of the solar cell

is 26% which gives 2.77W power at output terminal.

### III.II Energy Storage

Energy is stored on a single pack of NiCd rechargeable batteries [7]. This pack contains ten NiCd element each 1.2V, for a total of 12V. Battery capacity of each NiCd is 0.9Ah. Max. available energy is then 10.8Wh, equivalent to 38.9kJ.

All these batteries are charged from the power distribution bus which in turn is charged from the four solar panels via an hysteretic switching boost converter. Efficiency of the boost converter is 93%, therefore **1.84W** is the expected average power available at the PDB, which is used to recharge batteries. Expected recharge time is therefore for the single cell is 5.8h for the whole system is 58h. Worst case efficiency (discharge energy/charge energy) of battery, over the

temperature range and radiation environment is 80%. It results an average power available for all electronic systems of **8.64W**.

### III.III Power Sinks

AraMiS-C1 is designed for low power consumption. All components have been chosen in commercial low-power domain. Typical power consumption of on-board systems (power management tile, communication tile and payload) is summarized in Table 1, where both peak and average power are measured respectively. Subsystem that consume high power such as in the case of magnetorquer subsystem given in table 2, the solution is to keep the other subsystem either in idle state or completely switched off when magnetorquer subsystem is active.

Subsystems	Power sink	Duty cycle (%)	Power when active (mW)	Number of Subsystems	Total active Power (mW)	Avg. power (mW)
Power Management Tile	Magnetometer	1	89.3	4	357.2	3.572
	Gyroscope	5	45	4	180	9
	Housekeeping Sensors	5	5	4	20	1
	Tile Processor	100	5.5	4	22	22
Communication Tile	UHF Communication (Receive Mode)	8.33	50	1	50	5
	S-Band Communication 2.4GHz receiver	8.33	50	1	50	5
	Standard telemetry transmission, 435MHz: active max. 2s every minute	3.33	5600	1	5600	185
	Standard telemetry transmission, 2.4GHz: active max. 2s every minute	3.33	3000	1	3000	100
Payload		100	5	1	5	5

Table 1: Peak and average power of AraMiS-C1 subsystems

Magnetorquer System	Power Sink (W)	Activation time per month (sec)	Energy (joule)
Magnetic Torque Actuator	0.254	21	5.59
Magnetorquer Coil (Four coils in series)	1.35	21	83.7

Table 2: Energy per maneuver for the magnetorquer system of AraMiS-C1

Peak Power Consumed ( $P_{peak}$ )	5.627W
Average Power Consumed ( $P_{avg}$ )	335.57mW
Energy/night ( $E_{night}$ )	1.19kJ
Peak Solar Power ( $P_{solar\_peak}$ )	2.77W
Average Solar Power ( $P_{solar\_avg}$ )	1.98W
Battery Energy Storage ( $E_{store}$ )	38.9kJ
Battery Maximum Power ( $P_{max\_bat}$ )	10.8W
Battery Energy Life Cycle ( $LC_{battery}$ )	4.3years (500cycles)
Packet Energy (S-band @ 500kbps, 256 Bytes)	4.096mJ
Packet Energy (UHF @ 9600bps, 256 Bytes)	213.3mJ

Table 3: Power Budget of AraMiS-C1

Maximum power (5.6W) is consumed during active UHF transmission. During this stage all other subsystems are switched off except tile processor and payload. The power consumed during this stage is peak power given in the above table. Satellite orbit period is 100 minutes, and about 40% of the total time, it remains in dark zone. The energy consumed per night is 1.19kJ. Battery energy storage is 38.9kJ which results in battery energy life cycle of 4.3 years.  $P_{peak}$ ,  $P_{avg}$  and  $E_{night}$  should always be less than  $P_{max\_bat}$ ,  $P_{solar\_avg}$  and  $E_{store}$  respectively. Power budget calculated in table 3 satisfy the above criteria. Which means that EPS of AraMiS-C1 will guarantee nominal operation without troubles.

### CONCLUSION

The EPS presented in this paper represents a fully functional system which can fulfill the power requirement of a CubeSat standard nano-satellite. The system also has different sensors in order to guarantee reliable and safe operation. A detailed solar panels fault tolerance analysis has been performed. Finally power budget is calculated in order to evaluate the EPS performance for the satellite.

### REFERENCES

- [1] Michael Dowd, How Rad Hard Do You Need? The Changing Approach To Space Parts Selection?, Marketing and Sales, Maxwell Technologies Microelectronics
- [2] Stefano Speretta, Leonardo M. Reyneri, Claudio Sanso' e,

Maurizio Tranchero, Claudio Passerone, Dante Del Corso, "Modular Architecture for Satellites". 58th IAC , Hyderabad, India, 24 - 28 September 2007.

- [3] Claudio Passerone, Maurizio Tranchero, Stefano Speretta, Leonardo Reyneri, Claudio Sanso' e, Dante Del Corso, "Design Solutions for a University Nano-satellite", IEEEAC paper #1164, Version 2, Updated January 15, 2008.
- [4] "CubeSats Design Specifications" Rev.12, California State Polytechnic University.
- [5] Anwar Ali, Leonardo M. Reyneri and M. Rizwan Mughal, "Components selection for a simple boost converter on the basis of power loss analysis" 63<sup>rd</sup> IAC 2012 Naples Italy.
- [6] Elliott Ivan Gurrola, Sourabh Dongaonkar, "SPICE Simulation of Thin-Film Solar Cell Modules" Network for Computational Nanotechnology, NCN.
- [7] NiCd rechargeable batteries, "<http://media.digikey.com/pdf/Data%20Sheets/Sanyo%20Energy/KR-900AAEC.pdf>".