

**The role of HKT transporters in salinity
tolerance of tomato**

The candidate was financially supported by a scholarship from ENZA Zaden, and research was carried out at Department of Structural Biology, Vrije Universiteit, Amsterdam, The Netherlands, and at Laboratory of Molecular Biology, ENZA Zaden, Enkhuizen, The Netherlands.

Cover photo: Tomato plants growing in the greenhouse at the Vrije Universiteit, Amsterdam, The Netherlands. Photograph by the author.

VRIJE UNIVERSITEIT

The role of HKT transporters in salinity
tolerance of tomato

ACADEMISCH PROEFSCHRIFT

ter verkrijging van de graad Doctor aan
de Vrije Universiteit Amsterdam,
op gezag van de rector magnificus
prof.dr. F.A. van der Duyn Schouten,
in het openbaar te verdedigen
ten overstaan van de promotiecommissie
van de Faculteit der Aard- en Levenswetenschappen
op dinsdag 1 april 2014 om 11.45 uur
in de aula van de universiteit,
De Boelelaan 1105

door

Pedro Miguel Fidalgo de Almeida

geboren te Murtosa, Portugal

promoter: prof.dr. H. Lill

copromoter: dr.ir. A.H. de Boer

Contents

Chapter 1	
General introduction. Salt tolerance mechanisms	1
Chapter 2	
Na ⁺ leaf concentration as a criterion for selection of tomato accessions with different capacities to control Na ⁺ accumulation in leaf tissue	19
Chapter 3	
Analysis of physiological and genetic parameters in the salinity tolerance of 24 tomato accessions	50
Chapter 4	
Differences in shoot Na ⁺ accumulation between two tomato species are due to differences in ion affinity of HKT1;2	89
Chapter 5	
Assessment of SIHKT1;2 natural variation and characterization of mutated versions of SIHKT1;2 expressed in <i>Xenopus laevis</i> oocytes	114
Chapter 6	
<i>HKT1;1</i> from <i>Arabidopsis thaliana</i> or <i>HKT1;2</i> from <i>Solanum lycopersicum</i> expressed under the endogenous <i>AtHKT1;1</i> promoter complement the <i>athkt1;1</i> mutant	140
Chapter 7	
HKT transporters – State of the art	161
Chapter 8	
General Discussion	195
Summary	199
Nederlandse samenvatting	202
Acknowledgements	205

Chapter 1

General Introduction: salt tolerance mechanisms

Pedro Almeida¹ and Albertus H. de Boer¹

¹Vrije Universiteit Amsterdam, Faculty Earth and Life Sciences, Department of Structural Biology, NL-1081 HV Amsterdam, the Netherlands

Abstract

During their life cycle, plants face several biotic and abiotic stresses. Amongst abiotic stresses, salinity is one of the most widely spread causing enormous losses in plant yield and revenue. Here we review the causes of salinity stress, the effects of salinity on several plant physiological processes and different strategies used by plants to face the excess of Na⁺ in the soil and in the plant. The question of how Na⁺ enters the plant root, how it moves throughout the plant, how it is sequestered in specific structures is also addressed. The membrane transporters involved in the Na⁺ movement in the plant are discussed as well as the production and detoxification of ROS in several structures and the production and accumulation of osmolytes. Last we present an overview of what is known on the salinity tolerance of tomato and how culturing and genetic strategies may assist in making tomato plants more tolerant to salinity stress.

The problem of salinity worldwide – primary and secondary salinity

Among all abiotic stresses that plants face during their life cycle, salinity stress is most widespread and the most severe [1]. More than 800 million hectares worldwide, representing more than 6% of world's land area, are affected by salinity [2]. Besides naturally occurring salinization, poor irrigation practices can increase soil salinity [1,3-5]. This can have dramatic consequences as irrigated land (accounting only for 15% of total agricultural land) generates one third of all food produced worldwide due to its high productivity [4].

Salinization of soils can have natural or anthropogenic causes. Natural salinity is often called primary salinization and occurs via mineral weathering releasing soluble salts, and/or wind and rain deposition of oceanic water over a long period of time in arid and semi arid

regions [2,4]. Inland salt lakes and soils formed from saline parent material are examples of this. Secondary salinity is the term given to agricultural land recently affected by salinity due to the action of man. Tree clearing and over-irrigation or irrigation with saline water [4,5] often in combination with poor drainage of the soils are the main causes for secondary salinity. The combination of more water entering the soil and poor drainage practice causes the ground water table to rise, what leads to the concentration of salts in the root zone [4,6]. This poses a serious problem since, 20% of the world's irrigated land is currently suffering from salinity stress [7]. This decrease in arable land, combined with an increase in the world population poses a challenge in food productivity and growth sustainability [5].

Effects of salinity on plants

Although different salts are found at high concentrations in saline soils, NaCl is the dominant salt [8]. Due to this, the negative effects on the growth of the majority of plants caused by osmotic and ionic stresses are mainly due to the excess of Na⁺ ions [4,9,10]. Although for some plants from the genera *Vitis* and *Citrus* excess Cl⁻ is the main cause of toxicity [11], most of the research is focussed on Na⁺ and its entry point in the plant and not on Cl⁻.

From all the stresses that salinity poses on plants, osmotic and ionic stresses are the two most important ones. The first symptom observed when plants are subjected to salinity stress is a strong reduction in the growth rate. This is caused by the salt around the roots, which inhibits water uptake and affects water loss from the leaves [5]. Although the loss of cell volume and turgor is transient [4], the reduction in cell elongation and cell division during long periods of salinity are the causes of slower leaf appearance and smaller final size [1,4,5]. The reduction of lateral shoot formation and the earlier flowering with reduced florets occur also during long periods of salinity [5].

ROS formation due to high Na⁺ accumulation

Na⁺ toxicity is caused mainly by the problem of discrimination between K⁺ and Na⁺ ions for plant ion transporters and enzymes [12]. Due to excessive Na⁺ present in the soil, K⁺ uptake by roots can be disrupted, leading to the replacement of K⁺ by Na⁺ inside the cells as enzymatic co-factor, causing the loss of protein function [5,12]. Besides the toxic effects imposed on enzymes, membranes, acquisition of nutrients and in photosynthetic rate by high Na⁺ concentrations in the cytosol of plant cells, an increase in the production of reactive oxygen species (ROS) is also observed [12-14]. Hydroxyl radical (*OH), superoxide (O₂^{*-}), hydrogen peroxide (H₂O₂) [15], and singlet oxygen (¹O₂) [16] are the ROS produced. Due to

photosynthesis, the oxygen concentration in the chloroplasts is high and electrons can be abundant, what makes chloroplasts main producers of reactive oxygen species [17]. To cope with the negative effects of ROS, plants possess several detoxifying enzymes. Superoxide dismutase (SOD) converts O^{*2-} to H_2O_2 and catalase (CAT) and several peroxidases (-PX) break down H_2O_2 [3]. Plants also have several antioxidant compounds present close to the chloroplasts [18], such as ascorbate, glutathione, α -tocopherol [3,19], which reduce ROS by turning them into less harmful compounds.

Salinity stress effect on ROS scavenging in tomato

Environmental stresses like salinity disrupt the balance between the production and quenching of ROS resulting in oxidative stress [20]. To overcome this excessive production of ROS, plants induce the activity of the antioxidant enzymes [3]. Reports of increased activity of antioxidative enzymes exist for wheat [21], rice [22], radish [23], barley [24], pea [25], and tomato [26]. The antioxidant response of chloroplasts of *S. lycopersicum* and *S. pennellii* treated with NaCl were studied [27] and this showed that *S. lycopersicum* has increased levels of H_2O_2 and membrane lipid peroxidation in contrast to *S. pennellii* which has decreased levels when treated with NaCl. Salt induced damage of *S. pennellii* chloroplasts is alleviated due to increased activities of SOD, APX, MDHAR, GST PHGPX and other non-specific peroxidases of *S. pennellii* chloroplasts [27]. The antioxidative system of *S. lycopersicum* and *S. pennellii* peroxisomes and mitochondria were studied as well [28]. Mitochondria and peroxisomes of *S. pennellii* did not show any oxidative stress and this correlated with an increase in the activity of SOD, APX, MDHAR, dehydroascorbate reductase, and glutathione-dependent peroxidase. In peroxisomes of *S. lycopersicum* these enzymes remained at control levels during salinity stress treatments, what resulted in increased levels of lipid peroxidation and H_2O_2 and a reduced level of ascorbate [28].

Salinity stress and photosynthesis

Salinity affects photosynthesis by decreasing the water potential of the leaves [29]. Both aspects of salinity stress, i.e., total concentration of salt and ionic composition reduce the photosynthesis rate. On the one hand, high salinity reduces water potential in the soil, making water absorption by the roots more difficult. Less availability of water in the plant causes osmotic stress and inactivates photosynthetic electron transport [30]. On the other hand, high Na^+ uptake competes with the uptake of K^+ , leading to K^+ deficiency followed by a reduction in quantum yield of oxygen evolution as malfunctioning of photo-system II occurs [31]. Less

water available to the plant causes reductions in stomatal conductance, which results in less CO₂ availability for carboxylation reactions [32].

Different plant strategies for salinity tolerance

Munns and Tester [4], identify three categories of mechanisms of salinity tolerance:

- Tolerance to osmotic stress, reducing immediately cell expansion in root tips and young leaves and causing stomatal closure;
- Na⁺ exclusion by the roots, thus avoiding the accumulation of toxic Na⁺ concentrations in the leaves;
- Tissue tolerance due to the compartmentalization of Na⁺ and Cl⁻ in the vacuoles, what prevents the accumulation of high Na⁺ concentrations in the cytoplasm.

How Na⁺ enters the cells and is transported throughout the plant

A large portion of ion uptake in plants occurs via root hairs [33] as they form most of the root surface area. Ca²⁺ seems to have a crucial role in Na⁺ uptake by the roots since Ca²⁺ sensitive and Ca²⁺ insensitive Na⁺ uptake appears to be present in the roots [34]. Na⁺ enters the cytoplasm of epidermal and cortical root cells driven by the negative membrane potential of these cells [34]. Non-selective cation channels (NSCC) are assumed to be involved in the Ca²⁺ sensitive Na⁺ influx [10,35] although the genetic nature of these channels is still not clear [34]. Cyclic nucleotide-gated channels (CNGCs) [36], and glutamate-activated channels (GLRs) [37] are likely candidates for NSCC. Several other transporters might be involved in Ca²⁺-insensitive Na⁺ uptake like the transporters of the *HKT* gene family [38] and LCT1 [39]. In the *Arabidopsis* genome only one member of the *HKT* gene family is present [40]. No significant differences were observed between the total levels of Na⁺ in the wild type plants and *athkt1;1* mutants suggesting that, in *Arabidopsis*, HKT1;1 is not involved in Na⁺ uptake from the medium [41,42]. In contrast to *Arabidopsis*, rice has nine members of the *HKT* gene family [43]. The expression of *OsHKT2;1* [44] and *OsHKT2;2* [45] is consistent with a possible role in Na⁺ uptake [33] from the external medium [33]. In wheat, the reduction of wheat *TaHKT2;1* expression was accompanied by a reduction in the Na⁺ accumulation in roots and by an improved tolerance to stress [46], showing that the wheat HKT2;1 is likely involved in Na⁺ uptake from the external medium.

Radial transport of Na⁺ in the root

After entering the root, water and Na⁺ can follow two different pathways before reaching the xylem stream. In one pathway, called symplastic pathway, water and Na⁺ move radially from the cortical cells to the stele cells via plasmodesmata of adjacent cells [47]. After reaching the symplast of stelar cells Na⁺ ions need to pass the plasma membrane of xylem parenchyma cells (XPC) to be loaded into the xylem [34]. Protein mediated Na⁺ transport also occurs between adjacent cells where ions released by one cell in the apoplast is taken up by a neighbouring cell [48]. In the other pathway, called apoplastic, water and dissolved ions move through the apoplast space (cell walls) between adjacent cells until they reach the endodermis where the Casparian band poses a barrier to further flow. To overcome this barrier, water and ions have to pass the plasma membrane of endodermal cells to enter the symplast. From hereon they follow the symplast pathway.

In *Arabidopsis*, the expression of *CHX21* (member of the putative Na⁺/H⁺ antiporter family) in the plasma membrane of endodermal cells is consistent with a role in ion selectivity [49]. The *Arabidopsis atchx21* mutant shows lower xylem Na⁺ concentration as well as lower Na⁺ accumulation in leaves when compared to wild type plants, suggesting that AtCHX21 has a role in Na⁺ efflux from the endodermal cells into the stele [49]. Nevertheless, more studies are still necessary to evaluate the salinity tolerance of this mutant [33].

Loading of Na⁺ into the xylem

Transport of Na⁺ across the plasma membrane of xylem parenchyma cells (XPCs) is the last step in radial ion movement from soil to the transpiration stream. Between 10 to 15% of the xylem elements are in contact with XPCs [50]. The estimated electrical membrane potential difference between XPCs and the xylem is -100 mV [51]. This makes the export of Na⁺ into the xylem a secondary active process in situations of no salinity stress. However, in situations of moderate to high salinity stress, xylem loading might happen passively, down the electrochemical potential of Na⁺. A high cytosolic Na⁺ concentration in XPCs that have a depolarized plasma membrane facilitates the movement of Na⁺ into the xylem [52,53].

It has been hypothesized that in *Arabidopsis* the Na⁺/H⁺ antiporter SOS1 has a role in the loading of Na⁺ into the xylem [52]. This hypothesis is supported by the observation that SOS1 is expressed in stelar cells of the roots and also by the fact that *sos1* mutants accumulate less Na⁺ in the shoots as compared to wild-type plants [52]. Besides, the acidification of the xylem of *Plantago maritima* and barley also resulted in a higher accumulation of Na⁺ in the xylem

sap [54]. In contrast, in *Solanum lycopersicum* plants grown at low (25 mM) and high (100 mM) NaCl, low *SISOS1* expression levels correlate with high concentrations of NaCl in the leaves (but not stems) in comparison with wild-type plants [55]. Although SOS1 does seem to have a role in Na⁺ xylem loading, other proteins involved in this process are important as well. The observation that ABA can stimulate the extrusion of H⁺ into the xylem and that this in turn stimulates the Na⁺/H⁺-mediated transport of Na⁺ into the xylem [56] points to a role for plasma membrane H⁺-ATPases in Na⁺ xylem loading [57].

Unloading of Na⁺ from the xylem - HKT genes and models of action

Many articles have been published on the role of AtHKT1;1 in Na⁺ homeostasis in saline conditions [40,58-64]. *athkt1;1* mutant plants show increased accumulation of Na⁺ in the shoots but decreased Na⁺ accumulation in the roots when compared to wild-type plants [41,65-67]. Two models were proposed to explain the mode of action of HKT1;1 in *Arabidopsis* [41,64]. The first model proposed [41] is based on the observation that EMS *athkt1;1* mutants show less Na⁺ accumulation in the phloem sap and no differences in Na⁺ accumulation in the xylem when compared to wild-type plants. Combined with the phloem specific *AtHKT1;1* gene expression pattern, a model was presented where AtHKT1;1 has a role in the reduction of the net influx of Na⁺ in the shoots by xylem unloading, followed by transport to the phloem where it is transported back to the roots [41]. This model is called the “recirculation model”. Later, a different model was proposed where AtHKT1;1 acts by unloading Na⁺ from the xylem into the XPCs of the roots [64]. This model is supported by the observations that both T-DNA and fast neutron *athkt1;1* mutants show a significant increase in the concentration of Na⁺ present in the xylem sap and in the shoots as compared to the wild type plants [64]. Moreover, immuno-staining with an anti-AtHKT1;1 antibody showed that AtHKT1;1 is localized at the plasma membrane of the XPCs [64]. This model is called “exclusion model” and is supported by other studies [59,61].

Studies into the role of HKT1 genes/proteins in rice OsHKT1;5 [68], wheat TaHKT1;4 [69] and TaHKT1;5 [70] point to a role comparable to that of the *Arabidopsis* AtHKT1;1. The fact that *Arabidopsis*, rice and wheat possess HKT transporters with a similar function in Na⁺ unloading from the xylem does not invalidate [71] the recirculation model postulated for AtHKT1;1 [41]. Although the Na⁺ movement via the phloem is assumed to be negligible [50], studies carried out with lupin [72], sweet pepper [73], maize [74] and *Solanum pennellii* [75], show that recirculation via the phloem might occur [34]. The fact that species as different as *Arabidopsis*, rice and wheat show this HKT-based Na⁺ detoxification mechanism in the

xylem points out to a conserved Na⁺ tolerance mechanism in glycophytes [71]. An in-depth review on HKT transporters can be found in Chapter 7.

Efflux of Na⁺ back to the external medium

The mechanism of Na⁺ extrusion has extreme importance in salinity tolerance as it prevents the accumulation of high concentrations of Na⁺ in the cytosol and the translocation of Na⁺ to the shoots. A role of the plasma membrane located Na⁺/H⁺-antiporter SOS1 in the extrusion of Na⁺ to the outer environment at the root tip [52] and from mature epidermal zones of *Arabidopsis* roots [76] has been proposed. A recent paper [60] showed that in four *Arabidopsis thaliana* ecotypes, the lower Na⁺ shoot concentration was due to a higher *AtSOS1* expression in the roots. This is in line with previous reports where the constitutive over-expression of *AtSOS1* was shown to reduce total Na⁺ accumulation in the whole plant by 50% [77], and the hyperaccumulation of Na⁺ and reduced survival of *atsos1* knockout mutants [52]. These results indicate that the main function of SOS1 is pumping Na⁺ from the root cytoplasm back to the growth medium. This conclusion is supported by the fact that the *SOS1* expression was observed also in epidermal tissues, first only at the root tip [52] but later also along the whole root [76].

In addition to these results, the analysis of *AtSOS1::GUS* or *-GFP* reporter gene fusions showed that *SOS1* is also expressed along the vascular tissue [52]. This expression pattern leads to the assumption that SOS1 also pumps Na⁺ into the xylem resulting in increased shoot Na⁺ accumulation, unless some unknown mechanism would target the protein towards the side of the cell opposite to the xylem [60]. Although Na⁺-efflux from the root into the medium and loading of Na⁺ into the xylem may be carried out simultaneously by SOS1 in order to keep root Na⁺ concentrations low, further studies are necessary to investigate how the tissue specific expression and regulation of SOS1 occurs.

Ion compartmentalization.

The actual rise in Na⁺ concentration in the cytosol under salinity stress is still controversial [10]. Tester and Davenport have reviewed this topic and state that the Na⁺ concentration in the cytosol does not seem to exceed 30 mM [50]. It is widely accepted that during salinity stress the excess Na⁺ ions present in the cytoplasm interact with cytosolic enzymes and have a negative effect of their function. According to Munns and Tester, the critical threshold for cytosolic Na⁺ is close to 100 mM because Na⁺ concentrations above 100 mM are toxic for the majority of cytosolic enzymes [4]. So, there is a gap between the estimated levels of Na⁺ in

the cytosol under salt stress (30 mM) and the critical threshold for Na⁺ concentrations that enzymes can cope with (100 mM) of about 70 mM. This illustrates how much is still unknown in terms of plant salinity tolerance. Nevertheless, Na⁺ ions have to be retrieved from the cytosol during salinity stress [34], either via efflux or compartmentalization in the vacuole [12]. Compartmentalization in the vacuole of Na⁺ ions is an effective mechanism to avoid the toxic effects of Na⁺ in the cytosol [33]. The transport of Na⁺ from the cytoplasm into the vacuole occurs via NHX Na⁺-H⁺-antiporters. These antiporters work in close relation with the V-H⁺-ATPase and the H⁺-PPase which create the proton motive force to energize the ‘uphill’ transport of Na⁺ ions mediated by the NHX transporters. NHX transporters were first discovered in *Arabidopsis thaliana* (who comprises six isoforms) [78]. AtNHX1 mediates, in plant vacuoles, both Na⁺/H⁺ and K⁺/H⁺ exchange [79,80] and it is possible that the SOS pathway has a role in NHX regulation [81]. When over-expressed, NHX confers increased salinity tolerance to a plethora of plants including *Arabidopsis* [79], *Brassica napus* [82]; *Beta vulgaris* [83], rice [84]; maize [85], wheat [86]; cotton [87] and also tomato [88].

Besides their role in vacuolar Na⁺ sequestration, other functions for NHX transporters have been reported as well: cellular K⁺ homeostasis and cell expansion [89,90], vesicular trafficking and protein targeting [91,92], as well as endosomal pH regulation [93]. The tomato SINHX2 protein was shown to be involved in K⁺ but not Na⁺ homeostasis [90]. SINHX2 is a K⁺/H⁺ antiporter and enables the maintenance of high K⁺ concentrations in intracellular compartments during salinity stress when expressed in yeast [90]. *SINHX3* was recently mapped to a QTL related to leaf Na⁺ accumulation [94], whereas *SINHX1* was associated with a QTL for Cl⁻ concentration in young leaves [95]. All these results show that plants have different *NHX* genes with different ion specificities, regulating K⁺, Na⁺ and H⁺ homeostasis in intra-cellular compartments [90,96]

Synthesis of compatible osmolites

With increased salinity in the growth medium, the water potential tends to become more negative. Water uptake by the roots becomes more difficult at more negative medium water potential and at very high salinity the water potential may become so negative that the plant roots lose water. One strategy employed by plants to face this problem is the synthesis of compatible solutes. Compatible solutes accumulate, at high concentrations, in the cytoplasm of stressed cells without disturbing intracellular biochemistry [5,97,98]. Most of the compatible solutes are also called osmoprotectants [12], as they act both by maintaining cell turgor and are involved in antioxidant and chaperoning via stabilization of biological

membranes and proteins [99-101]. The pH of the cytoplasm and luminal compartments of plant organelles is not disturbed by the presence of compatible solutes [3]. A common compatible solute in plants is proline [12]. The importance of proline in maintaining the water balance of the plant was shown by increasing proline synthesis through genetic engineering of tobacco, *Arabidopsis* and rice [102-105].

Besides proline, sugars - sucrose, glucose and fructose - are used for osmotic adjustment or protective mechanisms [106]. When tomato plants are treated with NaCl, glucose and fructose [107-110], as well as sucrose [107,109] concentrations increased. High sucrose concentrations have been correlated with higher salinity tolerance of some tomato cultivars [111]. Sucrose is not a reducing sugar, as it does not contain any anomeric hydroxyl groups. Glucose and fructose both contain these groups and are reducing sugars with an important role in protective mechanisms [110].

Salinity tolerance in *S. lycopersicum* – what is known and what we would like to know.

Tomato is a model crop to test marker-assisted selection and introduction of genes by transformation [112]. In relation to other dicotyledonous crops, its genetics are well known, it has the advantage that it can be transformed by several methodologies and its physiology in saline and non-saline conditions have been studied thoroughly [112]. Improvements in salinity tolerance of tomato have been achieved through two different general strategies: genetic transformation and culturing techniques.

Genetic transformation

Several studies have shown that over-expression of trans-genes [88,113-121] or expression of endogenous genes involved in the tolerance process [119,122-126] result in enhanced salinity tolerance. However, these positive results do not ensure that these improvements in salinity tolerance shown by tomato plants are good enough from an agronomic point of view [112,127].

Culturing techniques to improve salt tolerance

Priming of tomato seeds with 35 and 70 mM NaCl in irrigation water resulted in higher fruit yields when compared to non-primed seeds [128],[129]. Enhanced salt tolerance can also be achieved by priming at the seedling stage [130]. Five-leaf stage seedlings from a salt-sensitive tomato genotype primed with 35 mM NaCl for 15 days, had up to 29% higher yields than non-treated plants.

Drought pre-treatment also makes tomato plants more tolerant to salt stress [131]. Tomato plants treated with drought stress showed improved salt tolerance during a subsequent three week salt treatment in comparison to plants not exposed to a dry period [131]. Positive effects on the salinity tolerance were also observed in tomato plants grown from seedlings pre-treated with PEG [132].

The modification of the relative humidity around the plants can also be used to alleviate the water shortage created by salinity [133]. This was tested in tomato and proved to be efficient in counteracting the negative effects of salinity stress as misted plants treated with salt showed no weight reduction in comparison to non-misted plants treated with salt [133].

Grafting is also a technique used to enhance salinity stress in tomato plants. Experiments using the commercial tomato cultivar Jaguar as a scion grafted onto roots of Jaguar (control), Radja and Volgogradsjik showed that, in the presence of 50 mM NaCl, fruit yield was more than 60% higher in both grafting combinations when compared to the control grafting [112]. Grafting experiments with these same cultivars and the cultivar Pera showed increases in yield of 80% [134]. Changes in xylem ionic and hormonal status in a *S. lycopersicum* scion grafted onto a rootstock from a population of recombinant inbred lines (derived from a *S. lycopersicum* x *S. cheesmaniae*), correlated with increased crop productivity in tomato plants treated with salt [135].

Treating tomato plants with other compounds can also increase salinity tolerance. For instance, tomato plants under salinity stress (90 mM NaCl dissolved in Hoagland's Solution), treated with 2.18 μ M of adipic acid monoethylester and 1.75 μ M of 1,3-diaminepropane (known as inducers of the resistance against biotic stresses in tomato and pepper), showed faster and more efficient osmoregulation, reduced oxidative stress, reduced toxic ion uptake and growth enhancement under salinity, in comparison with tomato plants treated only with 90 mM NaCl [136]. The addition of 2.5 mM silicon to the growth medium of tomato plants treated with 80 mM NaCl proved to reduce the deleterious effects of salinity [137]. Although silicon treatment did not change Na^+ concentrations within plant parts nor water uptake, in comparison to non-silicon supplemented plants, water content was 40%, leaf turgor potential 42%, net photosynthesis 20% and water use efficiency 17% higher than that in non-silicon supplemented plants. Reduction in plant dry weight and total plant leaf area was only 31% and 22%, respectively, in comparison with control (not treated with NaCl) plants, whereas non-silicon supplemented plants showed a 55% and 58% reduction, respectively [137]. Although tomato plants do not produce glycine betaine (GB), they can take it up when exogenously applied [138] and use it to alleviate the negative effects of salinity [139]. Tomato

seedlings of two tomato cultivars (Patio and F144) irrigated with Hoagland's solution supplemented with 120 mM NaCl and 5 mM GB showed alleviated growth inhibition [139].

Tomato genome project

With the publication of the Tomato Genome in May 2012, the complete tomato genome sequence became available to the public. The availability of this information speeds up the map based cloning in tomato facilitating the functional analysis of tomato genes.

Outline of this thesis

In Chapter 1, an overview of the salt tolerance mechanisms relevant for the research questions addressed in this thesis are presented. The main aim of the research was to study the mechanisms of salinity tolerance in plants of the genus *Solanum* with special focus on the *HKT1;2* gene.

In Chapter 2, ninety-three different tomato accessions were compared for their Na⁺ accumulation in the leaves and twenty-four accessions were selected and used in a more in-depth study presented in Chapter 3.

In Chapter 3, different tissues of twenty-four accessions were analysed for physiological and genetic parameters known to have important roles in ion homeostasis and salinity stress adaptation.

In Chapter 4, *S. lycopersicum* and *S. pennellii* plants were treated with NaCl and their Na⁺ and K⁺ content analysed. *HKT1;2* expression analysis was correlated to the ion accumulation shown in both species. *SIHKT1;2* and *SpHKT1;2* were isolated and expressed in *Xenopus laevis* oocytes and their ion affinity and kinetics were studied.

In Chapter 5, *Solanum sp. HKT1;2*, isolated from all accessions used in Chapter 1, was used in a high resolution DNA melting (HRM) study to determine the presence of natural variance in the coding sequence of *HKT1;2*. Besides, several mutations were introduced in *SIHKT1;2* and their influence on the transport characteristics were tested by expressing these versions of *SIHKT1;2* in *Xenopus laevis* oocytes.

In Chapter 6, *athkt1;1* mutant plants were transformed with several WT and mutated *HKT1;2* genes from tomato and *Arabidopsis* (described in Chapter 5), as well as *SIHKT1;1*, and their role in ion homeostasis was assessed by analysing the Na⁺ and K⁺ accumulation in these plants.

In Chapter 7, a review on the state of the art of HKT transporters is presented.

In Chapter 8, the results of the work reported in this thesis are discussed within a broader context, and directions for future research are given.

References

1. Tuteja N (2007) Mechanisms of high salinity tolerance in plants. Osmosensing and Osmosignaling. San Diego: Elsevier Academic Press Inc. pp. 419-436.
2. FAO (2009) FAO land and plant nutrition management service. www.fao.org/ag/agl/agll/spush/.
3. Parida AK, Das AB (2005) Salt tolerance and salinity effects on plants: a review. *Ecotoxicology and Environmental Safety* 60: 324-349.
4. Munns R, Tester M (2008) Mechanisms of salinity tolerance. *Annual Review of Plant Biology* 59: 651-681.
5. Jawell MC, Campbell BC, Godwin ID (2010) Transgenic plants for abiotic stress resistance. In *Transgenic Crop Plants*, Kole, C., Michler, C., Abbot, A. G., Hall, T. C. (Eds.).
6. Rengasamy P (2006) World salinization with emphasis on Australia. *Journal Experimental Botany* 57: 1017-1023.
7. FAO (2008) FAO land and plant nutrition management service. www.fao.org/ag/agl/agll/spush/.
8. Zhang B, Wang H, Wang P, Zhang H (2010) Involvement of nitric oxide synthase-dependent nitric oxide and exogenous nitric oxide in alleviating NaCl induced osmotic and oxidative stress in *Arabidopsis thaliana*. *African Journal of Agricultural Research* 5: 1713-1721.
9. Blumwald E, Aharon GS, Apse MP (2000) Sodium transport in plant cells. *Biochimica et Biophysica Acta* 1465: 140-151.
10. Kronzucker HJ, Britto DT (2011) Sodium transport in plants: a critical review. *New Phytologist* 189: 54-81.
11. White PJ, Broadley MR (2001) Chloride in soils and its uptake and movement within the plant: A review. *Annals Botany* 88: 967-988.
12. Conde A, Chaves MM, Geros H (2011) Membrane transport, sensing and signaling in plant adaptation to environmental stress. *Plant and Cell Physiology* 52: 1583-1602.
13. Cheeseman JM (1988) Mechanism of salinity tolerance in plants. *Plant Physiology* 87: 547-550.
14. Skopelitis D, Paranychianakis N, Paschalidis K, Pliakonis E, Delis L, et al. (2006) Abiotic stress generates ROS that signal expression of anionic glutamate dehydrogenases to form glutamate for proline synthesis in tobacco and grapevine. *Plant Cell* 18: 2767-2781.
15. Halliwell B, Gutteridge JMC (1985) *Free Radicals in Biology and Medicine*. Oxford: Clarendon Press.
16. Elstner EF (1987) *Metabolism of activated oxygen species.*; Davies DD, editor. San Diego, CA: Academic Press.
17. Asada K, Takahashi M (1987) Production and scavenging of active oxygen radicals in photosynthesis. In: Kyle DJ, Osmond CB, Arntzen CJ, editors. *Photoinhibition*. Amsterdam: Elsevier. pp. 227-288.
18. Halliwell B (1982) The toxic effects of oxygen on plant tissues. Oberly LW, editor. Boca Raton, FL: CRC Press.
19. Foyer CH, Lelandais M, Edwards EA, Mullineaux PM (1991) The role of ascorbate in plants, interactions with photosynthesis and regulatory significance. In *Active oxygen/ oxidative stress and plant metabolism*. Pell, E., Steffen, K. (Eds). America Society of Plant Physiology, Rockville, MD.
20. Spychalla JP, Desborough SL (1990) Superoxide dismutase, catalase, and alpha-tocopherol content of stored potato tubers. *Plant Physiology* 94: 1214-1218.
21. Hernandez J, Jimenez A, Millineaux P, Sevilla F (2000) Tolerance of pea plants (*Pisum sativum*) to long-term salt stress is associated with induction of antioxidant defences. *Plant Cell and Environment* 23: 853-862.
22. Lee DH, Kim YS, Lee CB (2001) The inductive responses of the antioxidant enzymes by salt stress in the rice (*Oryza sativa* L.). *Journal Experimental Botany* 158: 737-745.

23. Muthukumarasamy M, Gupta SD, Pannerselvam R (2000) Enhancement of peroxidase, polyphenol oxidase and superoxide dismutase activities by triadimefon in NaCl stressed *Raphanus sativus* L. *Biologia Plantarum* 43: 317-320.
24. Liang YC (1999) Effects of silicon on enzyme activity and sodium, potassium and calcium concentration in barley under salt stress. *Plant and Soil* 209: 219-224.
25. Hernandez. J. A., Campillo A, Jimenez A, Alacon JJ, Sevilla F (1999) Response of antioxidant systems and leaf water relations to NaCl stress in pea plants. *New Phytologist* 141: 241-251.
26. Rodriguez-Rosales MP, Kerkeb L, Bueno P, Donaire JP (1999) Changes induced by NaCl in lipid content and composition, lipoxygenase, plasma membrane H⁺-ATPase and antioxidant enzyme activities of tomato (*Lycopersicon esculentum*, Mill) calli. *Plant Science* 143: 143-150.
27. Mittova V, Tal M, Volokita M (2002) Response of the cultivated tomato and its wild salt-tolerant relative *Lycopersicon pennellii* to salt-dependent oxidative stress: increased activities of antioxidant enzymes in root plastids. *Free Radicals Research* 36: 195-202.
28. Mittova V, Tal M, Volokita M, Guy M (2003) Up-regulation of the leaf mitochondrial and peroxisomal antioxidative systems in response to salt-induced oxidative stress in the wild salt-tolerant tomato species *Lycopersicon pennellii*. *Plant Cell and Environment* 26: 845-856.
29. Iyengar ERR, Reddy MP (1996) Photosynthesis in high salt tolerant plants. In *Hand Book of Photosynthesis*. Pesserkali, M. (Eds) Baten Rose, USA.
30. Allakhverdiev SI, Sakamoto A, Nishiyama Y, Inaba M, Murata N (2000) Inactivation of photosystems I and II in response to osmotic stress in *Synechococcus*, contribution of water channels. *Plant Physiology* 122: 1201-1208.
31. Ball MC, Chow WS, Anderson JM (1987) Salinity induced potassium deficiency causes a loss of functional photosystem II in leaves of grey mangroves, *Avicennia marina*, through depletion of the atrazine-binding polypeptide. *Australian Journal of Plant Physiology* 14: 351-361.
32. Brugnoli E, Bjorkman O (1992) Growth of cotton under continuous salinity stress: influence on allocation pattern, stomatal and non-stomatal components of photosynthesis and dissipation of excess light energy. *Planta* 187: 335-347.
33. Apse MP, Blumwald E (2007) Na⁺ transport in plants. *Febs Letters* 581: 2247-2254.
34. Plett DC, Moller IS (2010) Na plus transport in glycophytic plants: what we know and would like to know. *Plant Cell and Environment* 33: 612-626.
35. Demidchik V, Maathuis FJM (2007) Physiological roles of nonselective cation channels in plants: from salt stress to signalling and development. *New Phytologist* 175: 387-404.
36. Kaplan B, Sherman T, Fromm H (2007) Cyclic nucleotide-gated channels in plants. *FEBS Letters* 581: 2237-2246.
37. Davenport RJ (2002) Glutamate receptors in plants. *Annals of Botany* 90: 549-557.
38. Platten JD, Cotsaftis O, Berthomieu P, Bohnert H, Davenport RJ, et al. (2006) Nomenclature for HKT transporters, key determinants of plant salinity tolerance. *Trends in Plant Science* 11: 372-374.
39. Amtmann A, Fischer M, Marsh EL, Stefanovic A, Sanders D, et al. (2001) The wheat cDNA *LCT1* generates hypersensitivity to sodium in a salt-sensitive yeast strain. *Plant Physiology* 126: 1061-1071.
40. Uozumi N, Kim EJ, Rubio F, Yamaguchi T, Muto S, et al. (2000) The *Arabidopsis HKT1* gene homolog mediates inward Na⁺ currents in *Xenopus laevis* oocytes and Na⁺ uptake in *Saccharomyces cerevisiae*. *Plant Physiology* 122: 1249-1259.
41. Berthomieu P, Conejero G, Nublat A, Brackenbury WJ, Lambert C, et al. (2003) Functional analysis of AtHKT1 in *Arabidopsis* shows that Na⁺ recirculation by the phloem is crucial for salt tolerance. *Embo Journal* 22: 2004-2014.
42. Essah PA, Davenport R, Tester M (2003) Sodium influx and accumulation in *Arabidopsis*. *Plant Physiology* 133: 307-318.
43. Garciadeblas B, Senn ME, Banuelos MA, Rodriguez-Navarro A (2003) Sodium transport and HKT transporters: the rice model. *Plant Journal* 34: 788-801.
44. Horie T, Yoshida K, Nakayama H, Yamada K, Oiki S, et al. (2001) Two types of HKT transporters with different properties of Na⁺ and K⁺ transport in *Oryza sativa*. *Plant Journal* 27: 129-138.

45. Kader MA, Seidel T, Golldack D, Lindberg S (2006) Expressions of *OsHKT1*, *OsHKT2*, and *OsVHA* are differentially regulated under NaCl stress in salt-sensitive and salt-tolerant rice (*Oryza sativa* L.) cultivars. *Journal of Experimental Botany* 57: 4257-4268.
46. Laurie S, Feeney KA, Maathuis FJM, Heard PJ, Brown SJ, et al. (2002) A role for HKT1 in sodium uptake by wheat roots. *Plant Journal* 32: 139-149.
47. Pickard WF (2003) The role of cytoplasmic streaming in symplastic transport. *Plant, Cell and Environment* 26: 1-5.
48. Plett DC, Moller IS (2010) Na⁺ transport in glycophytic plants: what we know and would like to know. *Plant Cell and Environment* 33: 612-626.
49. Hall D, Evan A, Newbury H, Pritchard J (2006) Functional analysis of CHX21: a putative sodium transporter in *Arabidopsis*. *Journal of Experimental Botany* 57: 1201-1210.
50. Tester M, Davenport R (2003) Na⁺ tolerance and Na⁺ transport in higher plants. *Annals of Botany* 91: 503-527.
51. De Boer AH (1999) Potassium translocation into the root xylem. *Plant Biology* 1: 36-45.
52. Shi HZ, Quintero FJ, Pardo JM, Zhu JK (2002) The putative plasma membrane Na⁺/H⁺ antiporter SOS1 controls long-distance Na⁺ transport in plants. *Plant Cell* 14: 465-477.
53. Wegner LH, Sattelmacher B, Lauchli A, Zimmermann U (1999) Trans-root potential, xylem pressure, and cortical membrane potential of "low-salt" maize as influenced by nitrate and ammonium. *Plant, Cell and Environment* 22: 1549-1558.
54. De Boer AH, Volkov V (2003) Logistics of water and salt transport through the plant: structure and functioning of the xylem. *Plant, Cell and Environment* 26: 87-101.
55. Olias R, Eljakaoui Z, Li J, De Morales PA, Marin-Manzano MC, et al. (2009) The plasma membrane Na⁺/H⁺ antiporter SOS1 is essential for salt tolerance in tomato and affects the partitioning of Na⁺ between plant organs. *Plant Cell and Environment* 32: 904-916.
56. Clarkson DT, Hanson JB (1986) Proton fluxes and the activity of a stelar proton pump in onion roots. *Journal of Experimental Botany* 37: 1136-1150.
57. Vitart V, Baxter I, Doerner P, Harper JF (2001) Evidence for a role in growth and salt resistance of a plasma membrane H⁺-ATPase in the root endodermis. *The Plant Journal* 27: 191-201.
58. Baek D, Jiang JF, Chung JS, Wang BS, Chen JP, et al. (2011) Regulated *AtHKT1* gene expression by a distal enhancer element and DNA methylation in the promoter plays an important role in salt tolerance. *Plant and Cell Physiology* 52: 149-161.
59. Davenport RJ, Munoz-Mayor A, Jha D, Essah PA, Rus A, et al. (2007) The Na⁺ transporter AtHKT1;1 controls retrieval of Na⁺ from the xylem in *Arabidopsis*. *Plant Cell and Environment* 30: 497-507.
60. Jha D, Shirley N, Tester M, Roy SJ (2010) Variation in salinity tolerance and shoot sodium accumulation in *Arabidopsis* ecotypes linked to differences in the natural expression levels of transporters involved in sodium transport. *Plant Cell and Environment* 33: 793-804.
61. Moller IS, Gilliam M, Jha D, Mayo GM, Roy SJ, et al. (2009) Shoot Na⁺ exclusion and increased salinity tolerance engineered by cell type-specific alteration of Na⁺ transport in *Arabidopsis*. *Plant Cell* 21: 2163-2178.
62. Rus A, Baxter I, Muthukumar B, Gustin J, Lahner B, et al. (2006) Natural variants of AtHKT1 enhance Na⁺ accumulation in two wild populations of *Arabidopsis*. *PloS Genetics* 2: 1964-1973.
63. Rus A, Yokoi S, Sharkhuu A, Reddy M, Lee BH, et al. (2001) AtHKT1 is a salt tolerance determinant that controls Na⁺ entry into plant roots. *Proceedings of the National Academy of Sciences of the United States of America* 98: 14150-14155.
64. Sunarpi, Horie T, Motoda J, Kubo M, Yang H, et al. (2005) Enhanced salt tolerance mediated by AtHKT1 transporter-induced Na⁺ unloading from xylem vessels to xylem parenchyma cells. *Plant Journal* 44: 928-938.
65. Maser P, Eckelman B, Vaidyanathan R, Horie T, Fairbairn DJ, et al. (2002) Altered shoot/root Na⁺ distribution and bifurcating salt sensitivity in *Arabidopsis* by genetic disruption of the Na⁺ transporter AtHKT1. *Febs Letters* 531: 157-161.
66. Nelson DE, Koukoumanos M, Bohnert HJ (1999) *Myo*-inositol-dependent sodium uptake in ice plant. *Plant Physiology* 119: 165-172.

67. Horie T, Horie R, Chan WY, Leung HY, Schroeder JI (2006) Calcium regulation of sodium hypersensitivities of *sos3* and *athkt1* mutants. *Plant and Cell Physiology* 47: 622-633.
68. Ren ZH, Gao JP, Li LG, Cai XL, Huang W, et al. (2005) A rice quantitative trait locus for salt tolerance encodes a sodium transporter. *Nature Genetics* 37: 1141-1146.
69. Huang SB, Spielmeyer W, Lagudah ES, James RA, Platten JD, et al. (2006) A sodium transporter (HKT7) is a candidate for *Nax1*, a gene for salt tolerance in durum wheat. *Plant Physiology* 142: 1718-1727.
70. Byrt CS, Platten JD, Spielmeyer W, James RA, Lagudah ES, et al. (2007) HKT1;5-like cation transporters linked to Na⁺ exclusion loci in wheat, *Nax2* and *Kna1*. *Plant Physiology* 143: 1918-1928.
71. Horie T, Hauser F, Schroeder JI (2009) HKT transporter-mediated salinity resistance mechanisms in *Arabidopsis* and monocot crop plants. *Trends in Plant Science* 14: 660-668.
72. Munns R, Tonnet L, Shennan C, Gardner PA (1988) Effect of high external NaCl concentration on ion transport within the shoot of *Lupinus albus*. II. Ions in phloem sap. *Plant, Cell and Environment* 11: 291-300.
73. Blom-Zandstra M, Vogelzang S, Veen B (1998) Sodium fluxes in sweet pepper exposed to varying sodium concentrations. *Journal of Experimental Botany* 49: 1863-1868.
74. Qing DJ, Lu HF, Li N, Dong HT, Dong DF, et al. (2009) Comparative profiles of gene expression in leaves and roots of maize seedlings under conditions of salt stress and the removal of salt stress. *Plant and Cell Physiology* 50: 889-903.
75. Perez-Alfocea F, Balibrea MC, Alarcon JJ, Bolarin MC (2000) Composition of xylem and phloem exudates in relation to the salt-tolerance of domestic and wild tomato species. *Plant Physiology* 156: 367-374.
76. Shabala L, Cuin TA, Newman IA, Shabala S (2005) Salinity-induced ion flux patterns from the excised roots of *Arabidopsis sos* mutants. *Planta* 222: 1041-1050.
77. Shi HZ, Lee BH, Wu SJ, Zhu JK (2003) Overexpression of a plasma membrane Na⁺/H⁺ antiporter gene improves salt tolerance in *Arabidopsis thaliana*. *Nature Biotechnology* 21: 81-85.
78. Gaxiola R, Rao R, Sherman A, Grisafi P, Alper SL, et al. (1999) The *Arabidopsis thaliana* proton transporters, AtNHX1 and AVP1, can function in cation detoxification in yeast. *Proceedings of the National Academy of Sciences USA* 96: 1480-1485.
79. Ape MP, Aharon GS, Snedden WA, Blumwald E (1999) Salt tolerance conferred by overexpression of a vacuolar Na⁺/H⁺ antiport in *Arabidopsis*. *Science* 285: 1256-1258.
80. Venema K, Quintero FJ, Pardo JM, Donaire JP (2002) The *Arabidopsis* Na⁺/H⁺ exchanger AtNHX1 catalyzes low affinity Na⁺ and K⁺ transport in reconstituted liposomes. *Journal of Biological Chemistry* 277: 2413-2418.
81. Qiu Q, Guo Y, Quintero F, Pardo J, Schumaker K, et al. (2002) Regulation of vacuolar Na⁺/H⁺ exchange in *Arabidopsis thaliana* by the SOS pathway. *Journal of Biological Chemistry* 279: 107-125.
82. Zhang HX, Hodson JN, Williams JP, Blumwald E (2001) Engineering salt-tolerant *Brassica* plants: characterization of yield and seed oil quality in transgenic plants with increased vacuolar sodium accumulation. *Proceedings of the National Academy of Sciences USA* 98: 12832-12836.
83. Liu H., Wang Q.Q., Yu M.M., Zhang Y.Y., Wu Y.B., et al. (2008) Transgenic salt-tolerant sugar beet (*Beta vulgaris* L.) constitutively expressing an *Arabidopsis thaliana* vacuolar Na⁺/H⁺ antiporter gene, AtNHX3, accumulates more soluble sugar but less salt in storage roots. *Plant Cell and Environment* 31: 1325-1334.
84. Ohta M, Hayashi Y, Nakashima A, Hamada A, Tanaka A, et al. (2002) Introduction of a Na⁺/H⁺ antiporter gene from *Atriplex gmelini* confers salt tolerance to rice. *FEBS Letters* 532.
85. Yin XY, Yang AF, Zhang KW, Zhang JR (2004) Production and analysis of transgenic maize with improved salt tolerance by the introduction of *AtNHX1* gene. *Acta Botanica Sinica* 46: 854-861.
86. Xue ZY, Zhi DY, Xue GP, Zhang H, Zhao YX, et al. (2004) Enhanced salt tolerance of transgenic wheat (*Triticum aestivum* L.) expressing a vacuolar Na⁺/H⁺ antiporter gene with improved grain yields in saline soils in the field and a reduced level of leaf Na⁺. *Plant Science* 167: 849-859.

87. He C, Yan J, Shen G, Fu L, Holaday AS, et al. (2005) Expression of an *Arabidopsis* vacuolar sodium/proton antiporter gene in cotton improves photosynthetic performance under salt conditions and increases fiber yield in the field. *Plant and Cell Physiology* 46: 1848-1854.
88. Zhang HX, Blumwald E (2001) Transgenic salt-tolerant tomato plants accumulate salt in foliage but not in fruit. *Nature Biotechnology* 19: 765-768.
89. Apse MP, Sottosanto JB, Blumwald E (2003) Vacuolar cation/H⁺ exchange, ion homeostasis, and leaf development are altered in a T-DNA insertional mutant of AtNHX1, the *Arabidopsis* vacuolar Na⁺/H⁺ antiporter. *Plant Journal* 36: 229-239.
90. Venema K, Belver A, Marin-Manzano MC, Rodriguez-Rosales MP, Donaire JP (2003) A novel intracellular K⁺/H⁺ antiporter related to Na⁺/H⁺ antiporters is important for K⁺ ion homeostasis in plants. *The Journal of Biological Chemistry* 278: 22453-22459.
91. Bowers K, Boaz PL, Patel FI, Stevens TH (2000) The Na⁺/H⁺ exchanger Nhx1p is required for endosomal protein trafficking in the yeast *Saccharomyces cerevisiae*. *Molecular Biology of the Cell* 11: 4277-4294.
92. Brett CL, Tukaye DN, Mukherjee S, Rao R (2005) The yeast endosomal Na⁺(K⁺)/H⁺ exchanger Nhx1 regulates cellular pH to control vesicle trafficking. *Molecular Biology of the Cell* 16: 1396-1405.
93. Yamaguchi T, Fukada-Tanaka S, Inagaki Y, Saito N, Yonekura-Sakakibara K, et al. (2001) Genes encoding the vacuolar Na⁺/H⁺ exchanger and flower coloration. *Plant and Cell Physiology* 42: 451-461.
94. Villalta I, Reina-Sanchez A, Bolarin MC, Cuartero J, Belver A, et al. (2008) Genetic analysis of Na⁺ and K⁺ concentrations in leaf and stem as physiological components of salt tolerance in tomato. *Theoretical and Applied Genetics* 116: 869-880.
95. Villalta I, Bernet GP, Carbonell EA, Asins JM (2007) Comparative QTL analysis of salinity tolerance in terms of fruit yield using two *Solanum* populations of F7 lines. *Theoretical and Applied Genetics* 114: 1001-1017.
96. Pardo J, Cubero B, Leidi EO, Quintero FJ (2006) Alkali cation exchangers: roles in cellular homeostasis and stress tolerance. *Journal Experimental Botany* 57: 1181-1199.
97. Chen THH, Murata N (2002) Enhancement of tolerance of abiotic stress by metabolic engineering of betaines and other compatible solutes. *Current Opinion Plant Biology* 5: 250-257.
98. Bohnert HJ, Jensen RG (1996) Strategies for engineering water-stress tolerance in plants. *Trends in Biotechnology* 14: 89-97.
99. Hare PD, Cress WAJ, Staden V (1998) Dissecting the roles of osmolyte accumulation during stress. *Plant Cell and Environment* 21: 535-554.
100. Diamant S, Eliahu N, Rosenthal D, Goloubinoff P (2001) Chemical chaperones regulate molecular chaperones in vitro and in cells under combined salt and heat stresses. *Journal of Biological Chemistry* 276: 39586-39591.
101. McNeil SD, Nuccio ML, Hanson AD (1999) Betaines and related osmoprotectants. Targets for metabolic engineering of stress resistance. *Plant Physiology* 120: 945-949.
102. Roosens N, Hal Bitar F, Loenders K, Angenon G, Jacobs M (2002) Overexpression of ornithine- α -aminotransferase increases proline biosynthesis and confers osmotolerance in transgenic plants. *Molecular Breeding* 9: 73-80.
103. Valliyodan B, Nguyen H (2006) Understanding regulatory networks and engineering for enhanced drought tolerance in plants. *Current Opinion Plant Biology* 9: 189-195.
104. Yamada M, Morishita H, Urano K, Shiozaki N, Yamaguchi-Shinozaki K, et al. (2005) Effects of free proline accumulation in petunias under drought stress. *Journal of Experimental Botany* 56: 1975-1981.
105. Kavi Kishore PB, Sangam S, Amrutha RN, Laxmi PS, Naidu KR, et al. (2005) Regulation of proline biosynthesis, degradation, uptake and transport in higher plants: its implications in plant growth and abiotic stress tolerance. *Current Science* 88: 424-438.
106. Khelil A, Menu T, Ricard B (2007) Adaptive response to salt involving carbohydrate metabolism in leaves of a salt-sensitive tomato cultivar. *Plant Physiology and Biochemistry* 45: 551-559.
107. Schauer N, Zamir D, Fernie AR (2005) Metabolic profiling of leaves and fruit of wild species tomato: a survey of the *Solanum lycopersicum* complex. *Journal of Experimental Botany* 56: 297-307.

108. Sacher RF, Staples RC (1985) Inositol and sugars in adaptation of tomato to salt. *Plant Physiology* 77: 206-210.
109. Gao Z, Sagi M, Lips SH (1998) Carbohydrate metabolism in leaves and assimilate partitioning in fruits of tomato (*Lycopersicon esculentum* L.) as affected by salinity. *Plant Science* 135: 149-159.
110. Sgherri C, Kadlecova Z, Pardossi A, Navari-Izzo F, Izzo R (2008) Irrigation with diluted seawater improves the nutritional value of cherry tomatoes. *Journal of Agricultural and Food Chemistry* 56: 3391-3397.
111. Juan M, Rivero RM, Romero L, Ruiz JM (2005) Evaluation of some nutritional and biochemical indicators in selecting salt-tolerant tomato cultivars. *Environmental and Experimental Botany* 54: 193-201.
112. Cuartero J, Bolarin MC, Asins MJ, Moreno V (2006) Increasing salt tolerance in the tomato. *Journal of Experimental Botany* 57: 1045-1058.
113. Goel D, Singh AK, Yadav V, Babbar SB, Bansal KC (2010) Overexpression of osmotin gene confers tolerance to salt and drought stresses in transgenic tomato (*Solanum lycopersicum* L.). *Protoplasma* 245: 133-141.
114. Leidi EO, Barragan V, Rubio L, El-Hamdaoui A, Ruiz MT, et al. (2010) The AtNHX1 exchanger mediates potassium compartmentation in vacuoles of transgenic tomato. *Plant Journal* 61: 495-506.
115. Dong Q-L, Liu D-D, An X-H, Hu D-G, Yao Y-X, et al. (2011) *MdVHPI* encodes an apple vacuolar H⁺-PPase and enhances stress tolerance in transgenic apple callus and tomato. *Journal of Plant Physiology* 168: 2124-2133.
116. Seong ES, Cho HS, Choi D, Joung YH, Lim CK, et al. (2007) Tomato plants overexpressing *CaKRI* enhanced tolerance to salt and oxidative stress. *Biochemical and Biophysical Research Communications* 363: 983-988.
117. Goel D, Singh AK, Yadav V, Babbar SB, Murata N, et al. (2011) Transformation of tomato with a bacterial *codA* gene enhances tolerance to salt and water stress. *Journal of Plant Physiology* 168: 1286-1294.
118. Munoz-Mayor A, Pineda B, Garcia-Abellan J. O., Garcia-Sogo B, Moyano E, et al. (2008) The HAL1 function on Na⁺ homeostasis is maintained over time in salt-treated transgenic tomato plants, but the high reduction of Na⁺ in leaf is not associated with salt tolerance. *Physiology Plantarum* 133: 288-297.
119. Zhang C, Liu J, Zhang Y, Cai X, Gong P, et al. (2011) Overexpression of *SIGMEs* leads to ascorbate accumulation with enhanced oxidative stress, cold, and salt tolerance in tomato. *Plant Cell Reports* 30: 389-398.
120. Moghaieb REA, Nakamura A, Saneoka H, Fujita K (2011) Evaluation of salt tolerance in ectoine-transgenic tomato plants (*Lycopersicon esculentum*) in terms of photosynthesis, osmotic adjustment and carbon partitioning. *GM Crops* 2: 58-65.
121. Moghaieb REA, Tanaka N, Saneoka H, Hussein HA, Yousef SS, et al. (2000) Expression of betaine aldehyde dehydrogenase gene in transgenic tomato hairy roots leads to the accumulation of glycine betaine and contributes to the maintenance of osmotic potential under salt stress. *Soil Science and Plant Nutrition* 46: 873-883.
122. Galvez FJ, Baghour M, Hao G, Cagnac O, Rodriguez-Rosales MP, et al. (2012) Expression of *LeNHX* isoforms in response to salt stress in salt sensitive and salt tolerant tomato species. *Plant Physiology and Biochemistry* 51: 109-115.
123. Yanez M, Caceres S, Orellana S, Bastias A, Verdugo I, et al. (2009) An abiotic stress-responsive bZIP transcription factor from wild and cultivated tomatoes regulates stress-related genes. *Plant Cell Reports* 28: 1497-1507.
124. Pan Y, Seymour GB, Lu C, Hu Z, Chen X, et al. (2012) An ethylene response factor (ERF5) promoting adaptation to drought and salt tolerance in tomato. *Plant Cell Reports* 31: 349-360.
125. Munoz-Mayor A, Pineda B, Garcia-Abellan JO, Anton T, Garcia-Sogo B, et al. (2012) Overexpression of dehydrin *tas14* gene improves the osmotic stress imposed by drought and salinity in tomato. *Journal of Plant Physiology* 169: 459-468.

126. Orellana S, Yanez M, Espinoza A, Verdugo I, Gonzalez E, et al. (2010) The transcription factor SIAREB1 confers drought, salt stress tolerance and regulates biotic and abiotic stress-related genes in tomato. *Plant, Cell and Environment* 33: 2191-2208.
127. Flowers TJ (2004) Improving crop salt tolerance. *Journal Experimental Botany* 55.
128. Cano E, Bolarin MC, Perez-Alfocea F, Caro M (1991) Effects of NaCl priming on increased salt tolerance in tomato. *Journal of Horticultural Science* 66: 621-628.
129. Nakaune M, Hanada A, Yin YG, Matsukura C, Yamaguchi S, et al. (2012) Molecular and physiological dissection of enhanced seed germination using short-term low-concentration salt seed priming in tomato. *Plant Physiology and Biochemistry* 52: 28-37.
130. Cayuela E, Estan MT, Parra M, Caro M, Bolarin MC (2001) NaCl pretreatment at the seedling stage enhances fruit yield of tomato plants irrigated with salt water. *Plant and Soil* 230: 231-238.
131. Gonzalez-Fernandez JJ (1996) Tolerancia a la salinidad en tomate en estado de plantula y en planta adulta. Cordoba: Cordoba University.
132. Balibrea ME, Parra M, Bolarin MC, Perez-Alfocea F (1999) Cytoplasmic sucrolytic activity controls tomato fruit growth under salinity. *Australian Journal of Plant Physiology* 26: 561-568.
133. Li YL, Marcelis LFM, Stranghellini C (2004) Plant water relations as affected by osmotic potential of the nutrient solution and potential transpiration in tomato (*Lycopersicon esculentum* L.). *Journal of Horticultural Science and Biotechnology* 79: 211-218.
134. Estan MT, Martinez-Rodriguez MM, Perez-Alfocea F, Flowers T. J., Bolarin MC (2005) Grafting raises the salt tolerance of tomato through limiting the transport of sodium and chloride to the shoot. *Journal of Experimental Botany* 46: 703-712.
135. Albacete A, Martinez-Andujar C, Ghanem M, E, Acosta M, Sanchez-Bravo J, et al. (2009) Rootstock-mediated changes in xylem ionic and hormonal status are correlated with delayed leaf senescence, and increased leaf area and crop productivity in salinized tomato. *Plant Cell and Environment* 32: 928-938.
136. Flors V, Paradis M, Garcia-Andrade J, Cerezo M, Gonzales-Bosch C, et al. (2007) A tolerant behavior in salt-sensitive tomato plants can be mimicked by chemical stimuli. *Plant Signaling and Behaviour* 2: 50-57.
137. Romero-Aranda MR, Jurado O, Cuartero J (2006) Silicon alleviates the deleterious salt effect on tomato plant growth by improving plant water status. *Journal of Plant Physiology* 163: 847-855.
138. Makela P, Peltonen-Sainio P, Jokinen K, Pehu E, Setala H, et al. (1996) Uptake and translocation of foliar-applied glycinebetaine in crop plants. *Plant Science* 121: 221-230.
139. Chen S, Gollop N, Heuer B (2009) Proteomic analysis of salt-stressed tomato (*Solanum lycopersicum*) seedlings: effect of genotype and exogenous application of glycinebetaine. *Journal of Experimental Botany* 60: 2005-2019.

Chapter 2

Na⁺ leaf concentration as a criterion for selection of tomato accessions with different capacities to control Na⁺ accumulation in leaf tissue

Pedro Almeida^{1*}, Gert-Jan de Boer² and Albertus H. de Boer¹

¹Vrije Universiteit Amsterdam, Faculty Earth and Life Sciences, Department of Structural Biology, NL-1081 HV Amsterdam, the Netherlands

²Enza Zaden, Research and Development, Haling 1/E, 1602 DB Enkhuizen

*Corresponding author: p.m.fidalgodealmeida@vu.nl

Abstract

Plant growth and yield are strongly affected by abiotic stresses in general and salinity in particular. The excess of salts, particularly NaCl, in the growth medium can result in excessive accumulation of Na⁺ in the plant tissues. Excessive accumulation of Na⁺ in the photosynthetic tissues disrupts the ion balance in the cells causing the disturbance of several physiological processes. In this study we analysed the Na⁺ and K⁺ concentrations in leaf, stem and root tissue of 93 different tomato accessions. Results showed a high variation of Na⁺ accumulation in all the tissues analysed. This variation was also observed within accessions belonging to the same species. Based on the variation in Na⁺ accumulation in the leaves we decided to choose accessions, within species, showing contrasting behaviour in Na⁺ accumulation to be re-analysed in a more in-depth study shown on Chapter 3. Accessions LA 1959, LA 1938, LA 1325, LA 2695, GI 568, PI 126443, LA 0532, LA 0317, G 1560, LA 2167, PI 126449, LA 2860, LA 3320, Abigail, LA 2194, LA 1522, LA 1340, LA 2548, LA 3218, LA 1245, OT 2209, LA 2711, LA 1302 and Arbasson F1 were selected.

Introduction

Soil salinity is a major abiotic stress imposing limitations to agricultural and horticultural production [1,2]. These limitations result in significant losses in crop yields. The most common effect of salinity stress is the inhibition of growth [3,4]. This reduction in growth is often correlated with high concentrations of Na⁺ ions [4], especially in the shoots [5,6].

Among horticultural crops, tomato is one of the most important, and in many countries its fruits are an important source of vitamins, minerals and antioxidant compounds in human food [7]. However, due to the progressive salinization of irrigated land, areas for optimal growth of tomato are being reduced all over the world. To overcome this problem several attempts have been made to increase the salinity tolerance of cultivated plants [8]. In the case of tomato, wild species are a useful source of genes involved in salinity tolerance that can be transferred to cultivated tomato lines [7,9,10]. Although halophytic species exist in the tomato gene pool, the development of salt-resistant cultivars via conventional or biotechnological breeding has been a slow process [11,12]. Tomato wild accessions and cultivated *Solanum lycopersicum* have a contrasting behaviour in terms of Na⁺ accumulation. Whereas *S. lycopersicum* generally excludes Na⁺ ions [13,14] the majority of wild accessions behave as “includers” [15]. This is the case with *S. peruvianum* [16], *S. cheesmaniae* [17], *S. pimpinelifolium*, *S. hirsutum* and *S. pennellii* [18]. Nevertheless, the “includer” or “excluder” behaviour *per se*, does not define a tolerant or sensitive behaviour of tomato plants. The ecotypes Edkawi (LA6111) and Pera show a relatively salt tolerant behaviour despite having a higher “includer” capacity than other cultivars [13,19]. On the other hand, the cultivar Radja F1 combines a very efficient “excluder” capacity with a relatively salt-tolerant behaviour [20]. This example shows that, more important than the “includer” or “excluder” strategy, the maintenance of the concentration of toxic ions as close as possible to the physiological homeostatic capacity is of crucial importance to avoid negative toxic effects [15]. In other species, like *Arabidopsis* [1], and wheat [21], this lack of correlation between Na⁺ accumulation and salinity sensitivity was also observed.

The exclusion of Na⁺ from the shoots is still often being cited and used as an important mechanism to generate plant salinity tolerance [5,6]. A solid consensus exists about water and ion homeostasis being of extreme importance for plant survival and Na⁺ and K⁺ status being useful selection criteria for salinity tolerance [7,10,20]. The exclusion of Na⁺ from leaves is one strategy used by non-halophytes to improve their tolerance to salinity [22]. Unlike *Solanum lycopersicum*, several accessions of wild species like *S. pennellii*, have a halotolerant behaviour and can withstand high concentrations of Na⁺ in the shoots. This makes tomato species with different shoot and particularly leaf Na⁺ accumulation a model crop for comparative studies on the mechanisms of salt tolerance [23]. Maintaining a high cellular K⁺ content in the presence of excess Na⁺ is also critical for plant growth under saline conditions [22]. A high concentration of K⁺ in the cytosol when plants experience salinity stress contributes to a low Na⁺/K⁺ ratio. This ratio has a crucial role since in plants the cytosolic

ratio of K^+ and Na^+ is an important determinant of Na^+ toxicity [22]. In a recent study on salinity tolerance of several accessions of *S. lycopersicum*, those considered to be more salt tolerant were associated with low accumulation of Na^+ and lower Na^+/K^+ ratios [24].

As referred above, wild tomato species are of paramount importance in the development of new cultivars since these wild species possess an enormous genetic variation. Traits of existing cultivars can also be improved by the introduction of wild species genes. *Solanum lycopersicum* can easily be crossed with other *Solanum* species of the *Solanum lycopersicum* complex. This complex is formed by *S. pimpinellifolium*, *S. neorickii*, *S. chmielewskii* and *S. pennellii*. Developing salt-tolerant plant material via selection and genetic modification relies on the heritable variation that exists within crop species in response to salinity stress [24]. Fortunately, there is extensive information reported on tolerance to salinity both between and within plant species [24]. For instance, tomato [25] and rice [26], among other species, exhibit variance in salinity tolerance. However, studies in elite varieties have found little variation in the extent to which they can withstand salt stress [27]. The major reason is that the normal breeding target trait corresponds to increased yield only under optimal growing conditions. Therefore elite tomato cultivars contain only 10% of the total genetic variability amongst all tomato species [28]. Because tolerance means adaptation, modern breeding programs should take advantage of wild *Solanum* species since they are adapted to marginal environments [7]. Several wild alleles have been identified and several traits have been successfully integrated [29]. Such examples include commercial hybrids containing different combinations of up to 15 disease-resistance genes from wild species [30] and the introgression of *S. pennellii* genes to increase the soluble solids content of fruits [31], and β -carotene levels more than 15-fold [32].

In this study, 93 tomato accessions were salt treated and their tissue concentrations of Na^+ and K^+ were measured. Our results show that a great variation in ion accumulation exists between all accessions tested. This variation was also observed within plants belonging to the same species. From all accessions tested, 24 accessions that showed either a high or a low accumulation of Na^+ in the leaves were selected for a more in depth analysis of salt sensitivity, ion and solute accumulation and gene expression, as described in Chapter 3.

Material and methods

Plant material

Seeds of each tomato accession (Table 1) were surface sterilized by soaking in 1% (V/V) commercial sodium hypochlorite solution for 15 min and rinsed with sterile water 3 times.

After sterilization, seeds were sown in rock wool plugs soaked with half-strength Hoagland solution (one seed per rock wool plug). Plugs were covered with dry vermiculite to avoid dehydration. The experiment was designed in a randomised design consisting of one NaCl treatment, three biological replicates of 93 different accessions. Each biological replicate consisted of a pool of 7 to 10 plants. On alternate days plants were irrigated with half-strength Hoagland solution. Plants were kept in a climate chamber under a 14/10 hours photoperiod and a 20/18°C day/night temperature. Two weeks after sowing, salt treatment started. Salt-treated plants were irrigated, with half-strength Hoagland solution supplemented with 50 mM NaCl and the excess solution was allowed to drain. Control plants were irrigated with half-strength Hoagland's solution. Two days later, salt-treated plants were irrigated with half-strength Hoagland supplemented with 100 mM NaCl. Control plants were irrigated with half-strength Hoagland solution. Plants were irrigated every two days during three weeks with half-strength Hoagland solution or with half-strength Hoagland solution supplemented with 100 mM NaCl. After three weeks plants were harvested. Root, stem and leaf tissue of the biological replicates of each accession were harvested (roots were rinsed with demineralised water to remove Na⁺ from the medium), put in Greiner tubes, snap frozen in liquid nitrogen and transferred to an ultra freezer where they were kept at -80 °C. Frozen samples were dried using a freeze dryer (Christ Alpha 1-4 LD plus, Germany), for one week. When completely dry, samples were ground into a fine powder and stored in closed tubes at room temperature.

Na⁺ and K⁺ measurements

For the quantification of Na⁺ and K⁺ in the different tissues, between 50 and 100 mg of dried material was weighed in 2 ml tubes. 1 ml of water for trace analysis (Fluka Analytical, Sigma-Aldrich, USA) was added and the tubes were boiled for 10 min at 100 °C. Samples were then filtered in a 96 wells filter plate (Thermo Scientific, Rochester, USA) through centrifugation at 3,000 rpm for 3 min. For Na⁺ and K⁺ measurements 6 µl of the filtrate was diluted in 6 ml of ultrapure water (Fluka Analytical, Sigma-Aldrich, USA), and the resulting solution was analysed for Na⁺ and K⁺ concentrations using an atomic absorption spectrometer (AAAnalyst 200, PerkinElmer AAS). The AAS was calibrated using sodium and potassium atomic spectroscopy standard concentrate (Fluka Analytic, Sigma-Aldrich, USA), and the average of three technical replicas was used for the ion concentration calculations.

Statistical analysis

To assess the effect of salt treatment on Na^+ , K^+ and Na^+/K^+ per accession, we used the Student's t test. If the values were not normally distributed or if the assumption of homogeneity of variance was violated, the data was transformed. A Pearson's correlation was performed between the different accessions or in case of rank transformed data, a Spearman's rank correlation was performed. All analyses were conducted using SPSS 17.0.

Table 1: Names of all accessions tested in experiment 1.

Accession	Source	Species/Name	Acc. number
Arbasson F1	ENZA Zaden	<i>S. lycopersicum</i>	1
Elpida F1	ENZA Zaden	<i>S. lycopersicum</i>	2
Estrella F1	ENZA Zaden	<i>S. lycopersicum</i>	3
Hybrid		<i>S. lycopersicum</i>	4
Hybrid		<i>S. lycopersicum</i>	4
Newton F1		<i>S. lycopersicum</i>	5
G 1560	IVT	<i>S. habrochaites</i>	6
LA 2194	TGRC	<i>S. neorickii</i>	7
LA 2774	TGRC	<i>S. chilense</i>	8
LA 0247	TGRC	<i>S. neorickii</i>	9
OT.2209	IVT	<i>S. pimpinellifolium</i>	10
PI 128653	Vavilov	<i>S. peruvianum</i>	11
PI 247087	INRA	<i>S. habrochaites</i>	12
PI 126440	USDA	<i>S. corneliomuelleri</i>	13
LA 1401	TGRC	<i>S. galapagense</i>	14
LA 1028	TGRC	<i>S. chmielewskii</i>	15
LA 1316	TGRC	<i>S. chmielewskii</i>	16
GI 568	IVT	<i>S. corneliomuelleri</i>	17
LA 1938	TGRC	<i>S. chilense</i>	18
LA 1959	TGRC	<i>S. chilense</i>	19
PI 128659	USDA	<i>S. peruvianum</i>	20
LA 1508	TGRC	<i>S. galapagense</i>	21
LA 1412	TGRC	<i>S. cheesmaniae</i>	22
LA 1248	TGRC	<i>S. pimpinellifolium</i>	23
LA 1259	TGRC	<i>S. pimpinellifolium</i>	24
LA 1243	TGRC	<i>S. pimpinellifolium</i>	25
LA 1306	TGRC	<i>S. chmielewskii</i>	26
LA 2917	TGRC	<i>S. neorickii</i>	27
LA 1319	TGRC	<i>S. neorickii</i>	28
LA 1325	TGRC	<i>S. chmielewskii</i>	29
LA 2639B	TGRC	<i>S. chmielewskii</i>	30
LA 2678	TGRC	<i>S. chmielewskii</i>	31
LA 2681	TGRC	<i>S. chmielewskii</i>	32
LA 2695	TGRC	<i>S. chmielewskii</i>	33
LA 0531	TGRC	<i>S. cheesmaniae</i>	34
LA 0532	TGRC	<i>S. galapagense</i>	35
LA 0317	TGRC	<i>S. galapagense</i>	36
LA 1961	TGRC	<i>S. chilense</i>	37
LA 2747	TGRC	<i>S. chilense</i>	38
LA 3320	TGRC	<i>S. lycopersicum</i>	39

LA 2662	TGRC	<i>S. lycopersicum</i>	40
LA 3120	TGRC	<i>S. lycopersicum</i>	41
LA 1363	AVRDC	<i>S. habrochaites</i>	42
PI 126443	USDA	<i>S. corneliomuelleri</i>	43
PI 407543	USDA	<i>S. pimpinellifolium</i>	44
PI 407546	USDA	<i>S. pimpinellifolium</i>	45
PI 134417	USDA	<i>S. habrochaites glabratum</i>	46
CGN19145	IVT	<i>S. minutum</i>	47
LA 2744	TGRC	<i>S. peruvianum</i>	48
LA 1033	TGRC	<i>S. habrochaites</i>	49
LA 1223	TGRC	<i>S. pimpinellifolium</i>	50
PI 126935	USDA	<i>S. peruvianum</i>	51
LA 2981A	TGRC	<i>S. chilense</i>	52
LA 1245	TGRC	<i>S. pimpinellifolium</i>	53
Abigail	Hazera Genetics	<i>S. lycopersicum</i>	54
Daniela	Hazera Genetics	<i>S. lycopersicum</i>	55
EZ-8	ENZA Zaden	<i>S. lycopersicum</i>	56
LA 1302	TGRC	<i>S. pennellii puberulum</i>	57
LA 1340	TGRC	<i>S. pennellii</i>	58
LA 1522	TGRC	<i>S. pennellii</i>	59
LA 1624	TGRC	<i>S. habrochaites glabratum</i>	60
LA 1965	TGRC	<i>S. chilense</i>	61
LA 1971	TGRC	<i>S. chilense</i>	62
LA 2167	TGRC	<i>S. habrochaites</i>	63
LA 2548	TGRC	<i>S. peruvianum</i>	64
LA 2560	TGRC	<i>S. pennellii</i>	65
LA 2748	TGRC	<i>S. chilense</i>	66
LA 2750	TGRC	<i>S. chilense</i>	67
LA 2860	TGRC	<i>S. habrochaites glabratum</i>	68
LA 2879	TGRC	<i>S. chilense</i>	69
LA 2931	TGRC	<i>S. chilense</i>	70
964750062	Hortus Botanicus Nijmegen	<i>S. neorickii</i>	71
CGN15879	CGN	<i>S. habrochaites glabratum</i>	72
PI 126449	USDA	<i>S. habrochaites glabratum</i>	73
LA 1910	TGRC	<i>S. peruvianum</i>	74
LA 2773	TGRC	<i>S. chilense</i>	75
PI 126435	USDA	<i>S. peruvianum</i>	76
LA 0462	TGRC	<i>S. peruvianum</i>	77
LA 3218	TGRC	<i>S. peruvianum</i>	78
LA 1930	TGRC	<i>S. chilense</i>	79
LA 2711	TGRC	<i>S. lycopersicum</i>	80
LA 1278	TGRC	<i>S. peruvianum</i>	81
LA 1310	TGRC	<i>S. lycopersicum cerasiforme</i>	82
LA 1393	TGRC	<i>S. habrochaites</i>	83
LA 1579	TGRC	<i>S. pimpinellifolium</i>	84
LA 2874	TGRC	<i>S. lycopersicum cerasiforme</i>	85
LA 2880	TGRC	<i>S. chilense</i>	86
EZ-1	ENZA Zaden	<i>S. lycopersicum</i>	87
EZ-2	ENZA Zaden	<i>S. lycopersicum</i>	88
EZ-3	ENZA Zaden	<i>S. lycopersicum</i>	89
EZ-4	ENZA Zaden	<i>S. lycopersicum</i>	90
EZ-5	ENZA Zaden	<i>S. lycopersicum</i>	91
EZ-6	ENZA Zaden	<i>S. lycopersicum</i>	92
EZ-7	ENZA Zaden	<i>S. lycopersicum</i>	93

Results

Geographic distribution of all accessions

For this study we used tomato accessions collected in South America (Fig. 1). These accessions cover a wide area comprising the South of Ecuador, the whole territory of Peru, Northern Chile and Western Bolivia. Accessions from Galapagos Islands were also used in this study.

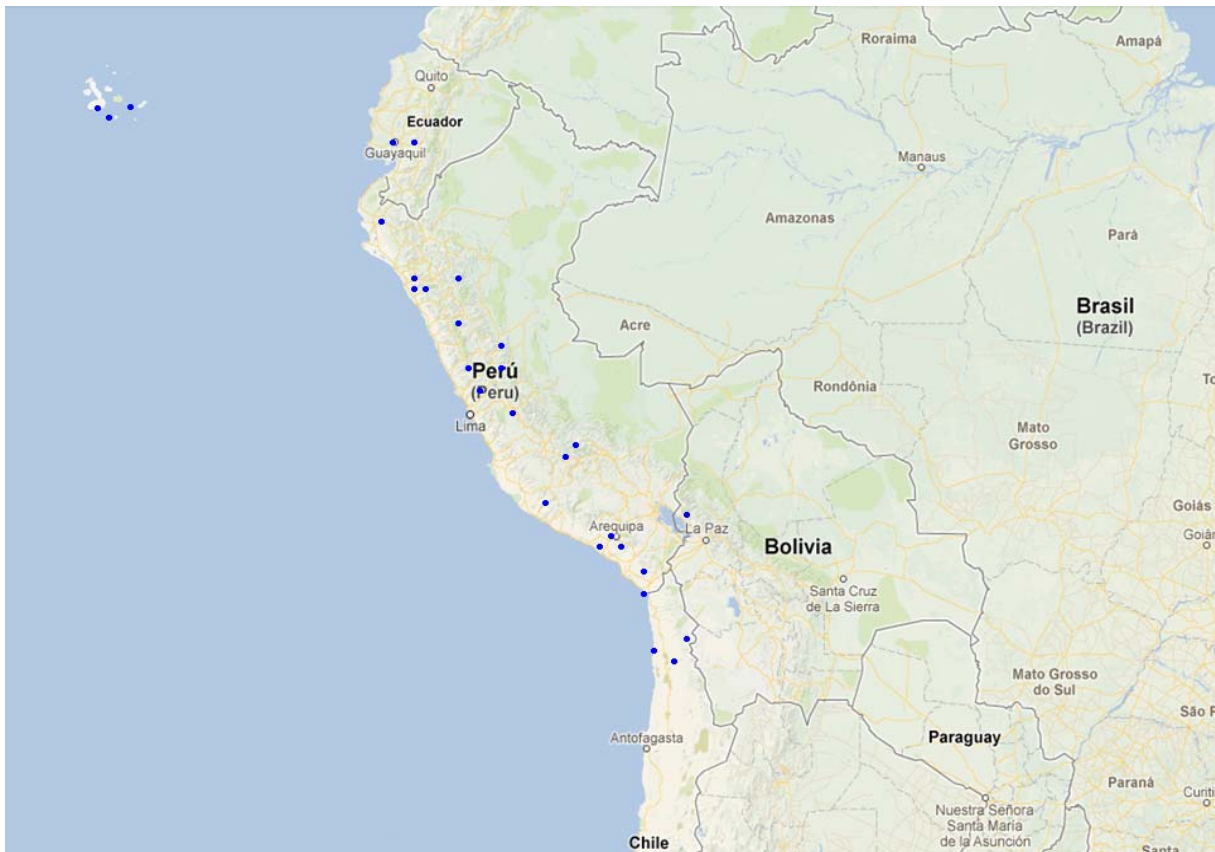

Figure 1: Tomato accessions used in this study were originated from an extensive area of South America comprising countries like Ecuador, Peru, Bolivia and Chile and the Galapagos Islands (<http://tgrc.ucdavis.edu/>. Adapted from <https://maps.google.com/maps?hl=pt-PT>

Ion quantification

Tomato accessions were grown for 3 weeks in rock wool plugs irrigated with half-strength Hoagland solution every two days. After three weeks two groups were created. One group was kept irrigated with half-strength Hoagland solution while the second group was irrigated with half-strength Hoagland solution supplemented with 50 mM NaCl and two days later supplemented with 100 mM NaCl. This level of Na⁺ was maintained for the remaining duration of the experiment. This experiment was used to select a restricted number of

accessions for a second experiment based on their different Na⁺ and K⁺ accumulation in the leaves.

Na⁺ concentration in leaves varied over three-fold amongst the 93 accessions (Fig. 2A), ranging from 0.60 mmol/g DW in *S. lycopersicum* Abigail to 1.93 mmol/g DW in *S. pennellii puberulum* LA 1302. Similar to differences in Na⁺ levels, variation in the K⁺ concentration was also observed (Fig. 2B). K⁺ concentrations ranged between 0.74 mmol/g DW in *S. neorickii* LA 1319 to 1.94 mmol/g DW in *S. peruvianum* LA 3218. The Na⁺ and K⁺ variation was reflected in the large degree of variation found in the Na⁺/K⁺ ratio (Fig. 2C).

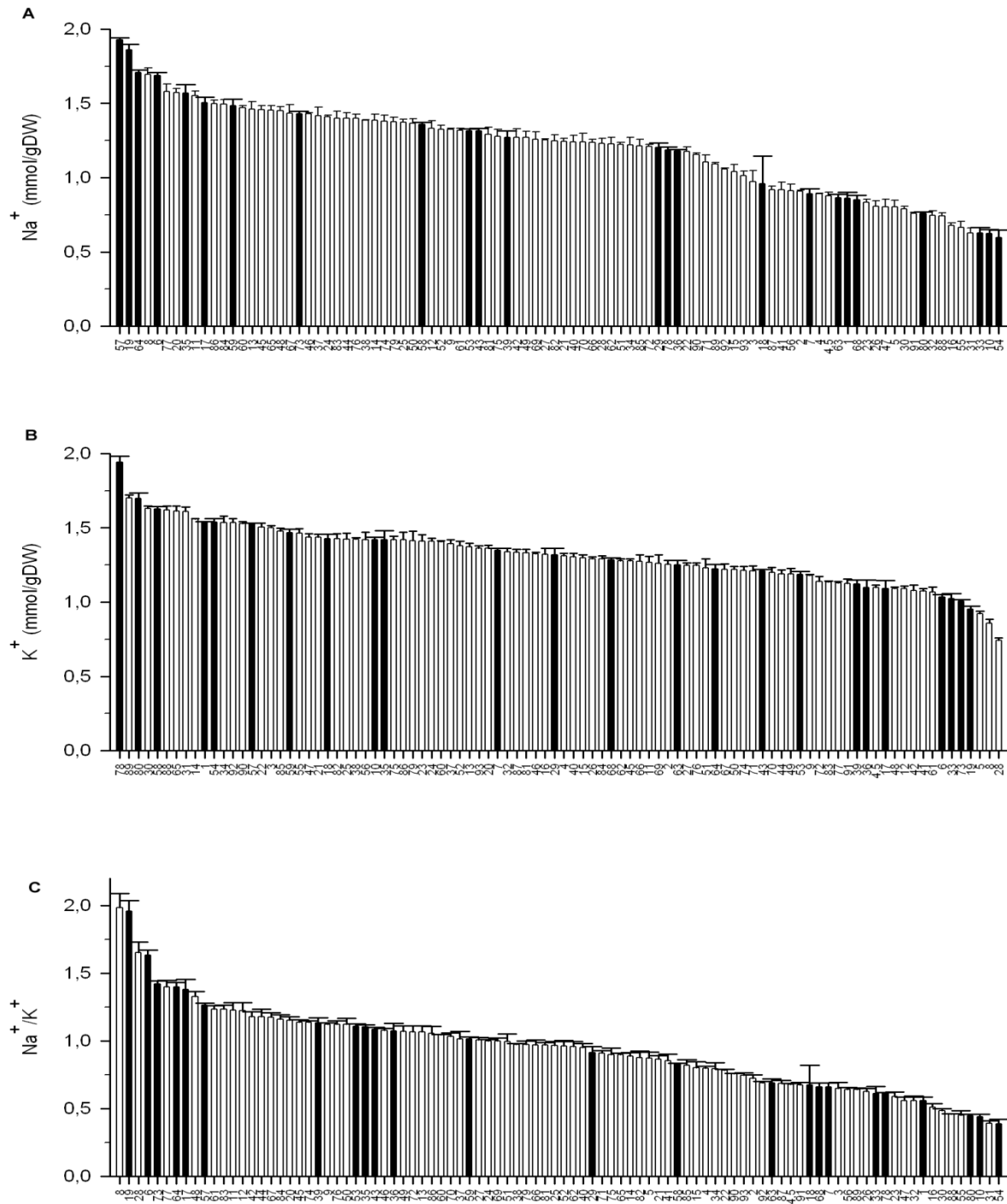

Figure 2: Responses to salt treatment of 93 tomato accessions showing (A) the range in leaf Na^+ concentration, (B) the range in leaf K^+ concentration and (C) the range in leaf Na^+/K^+ ratio of plants grown for 2 weeks at 100 mM NaCl. Black bars represent accessions chosen for a second experiment (see Chapter 3). Numbers on the x-axis represent all accessions tested according to the list shown in Table 2. Results are the means \pm SE of three biological replicas.

Table S1 shows the absolute concentrations of Na^+ , K^+ and Na^+/K^+ ratios measured in the (A) roots, (B) stems and (C) leaves of all accessions studied. Accessions are organised by species, and within species, by the amount of Na^+ accumulated in the leaves. A comparison of the Na^+ and K^+ values in the three tissues analysed showed that ions accumulated to higher concentrations in the stems as compared to roots and leaves. Nevertheless, a large variation in ion accumulation was observed between all accessions studied and also between accessions belonging to the same species. This variation was observed for both Na^+ and K^+ ion accumulation, in all tissues analysed.

The observed variation among accessions in Na^+ and K^+ concentrations in leaves were related, as can be seen in Fig. 3. Higher Na^+ concentrations correlated with lower K^+ concentrations in the leaves and vice-versa. Interestingly, this same analysis revealed no correlation between Na^+ and K^+ concentrations measured in the stems and in the roots.

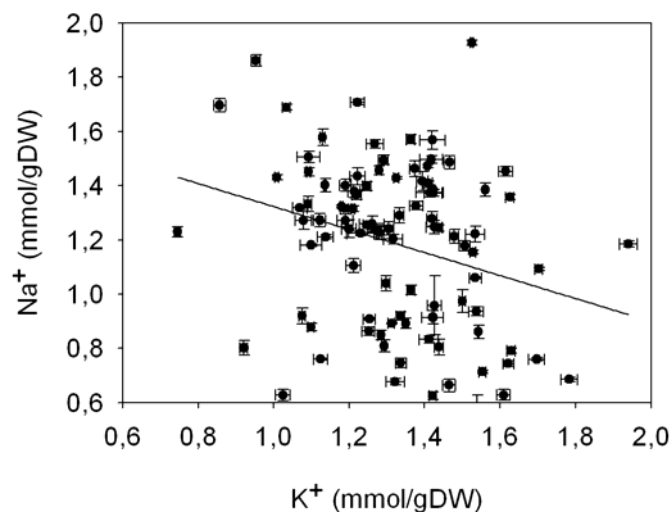

Figure 3: Relationship between Na^+ and K^+ accumulation in the leaves of all accessions used in this study treated with 100 mM NaCl for two weeks. Values indicate the means \pm SE of three biological replicas. Correlation analysis using Pearson correlation coefficient showed a significant correlation ($p < 0.05$).

Accessions chosen for further analysis

Figure 4 shows the leaf Na^+ concentrations of accessions grouped by species. Black bars represent accessions chosen for a subsequent experiment in which a more in depth physiological and genetic analysis was performed (Chapter 3). Table 3 lists the 24 accessions chosen for this experiment. The selected accessions tend to have contrasting behaviours in their leaf Na^+ accumulation. Although accessions PI 126449 and LA 1245 within their species

do not show the highest Na⁺ accumulation, they were selected on basis of the K⁺ level. Both accessions have a similar level of Na⁺ accumulation in the leaves when compared to those that showed the higher accumulation, but their K⁺ level is substantially different. In these two cases our selection was based on the similar Na⁺ but different K⁺ accumulation in the leaves.

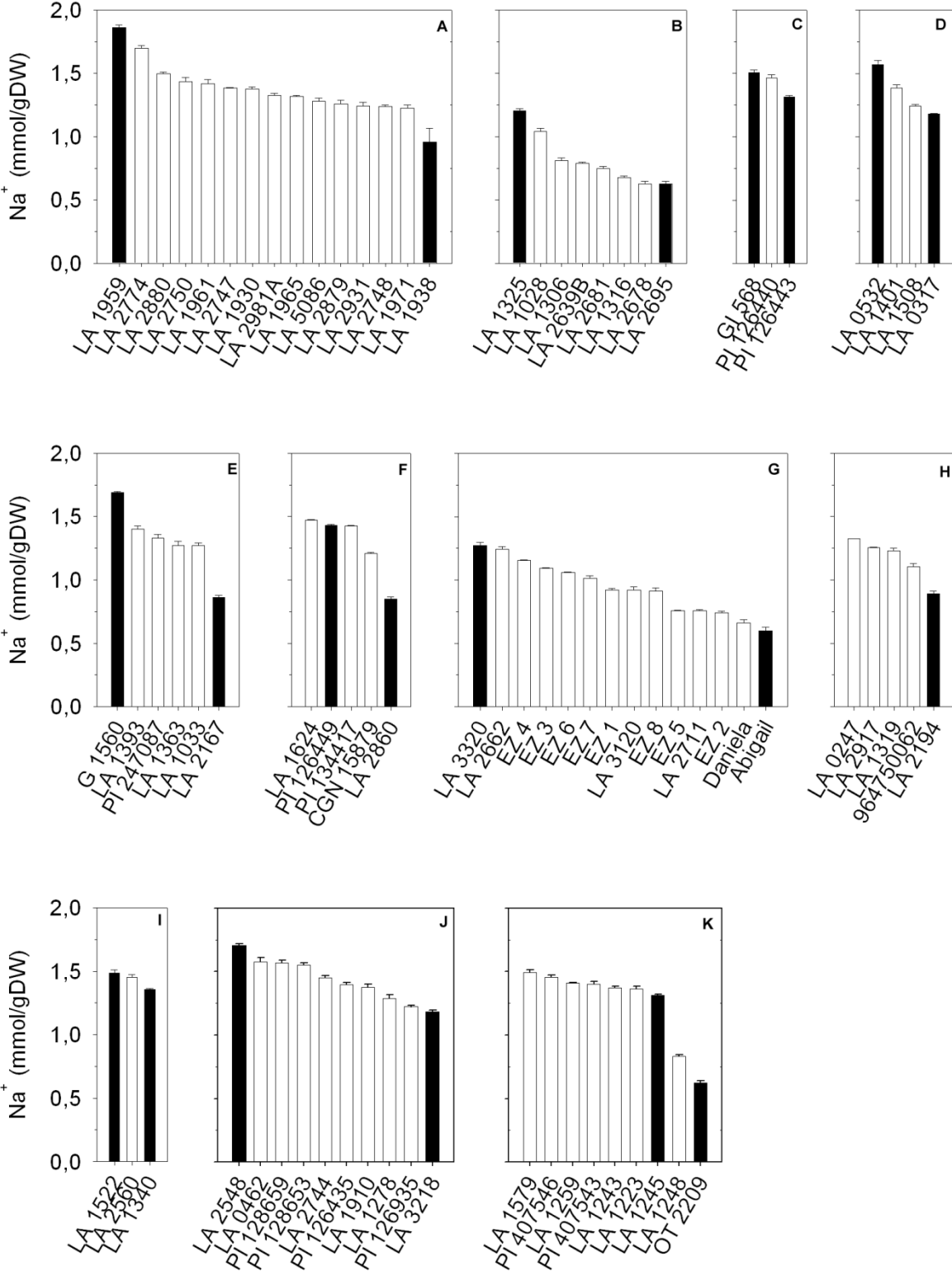

Figure 4: Grouped by species, selected accessions (black bars) show how they behave in comparison with other accessions from the same species. A) *S. chilense*; B) *S. chmielewskii*; C) *S. corneliomuelleri*; D) *S. galapagense*; E) *S. habrochaites*; F) *S. habrochaites glabratum*; G) *S. lycopersicum*; H) *S. neorickii*; I) *S. pennellii*; J) *S. peruvianum*; K) *S. pimpinellifolium*. Na⁺ accumulation in the leaves of 21 of the 24 accessions chosen to be used in experiment 2 grouped by species. 21 out of the total 24 accessions are represented here. *Solanum pennellii puberulum* LA 1302 was not plotted in a bar graph as it was the only accession from this species present in this study. Arbasson and Edkawi LA 2711 were both chosen as controls. Numbers on the x-axis represent ID numbers from the accessions as shown in Table 2.

Table 3: List of the accessions chosen from experiment 1 to be used in experiment 2.

Species	Accession number	ID
<i>S. chilense</i>	18	LA 1938
<i>S. chilense</i>	19	LA 1959
<i>S. chmielewskii</i>	29	LA 1325
<i>S. chmielewskii</i>	33	LA 2695
<i>S. corneliomuelleri</i>	17	GI 568
<i>S. corneliomuelleri</i>	43	PI 126443
<i>S. galapagense</i>	35	LA 0532
<i>S. galapagense</i>	36	LA 0317
<i>S. habrochaites</i>	6	G 1560
<i>S. habrochaites</i>	63	LA 2167
<i>S. habrochaites glabratum</i>	68	LA 2860
<i>S. habrochaites glabratum</i>	73	PI 126449
<i>S. lycopersicum</i>	54	Abigail F1
<i>S. lycopersicum</i>	39	LA 3320
<i>S. lycopersicum</i>	80	LA 2711
<i>S. neorickii</i>	7	LA 2194
<i>S. pennellii</i>	58	LA 1340
<i>S. pennellii</i>	59	LA 1522
<i>S. pennellii puberulum</i>	57	LA 1302
<i>S. peruvianum</i>	78	LA 3218
<i>S. peruvianum</i>	64	LA 2548
<i>S. pimpinellifolium</i>	10	OT 2209
<i>S. pimpinellifolium</i>	53	LA 1245
<i>S. lycopersicum</i>	1	Arbasson F1

Discussion

Several studies comparing the salinity tolerance of different accessions of *Arabidopsis* [40-43], wheat [2,44] and tomato [24,45] have been performed. For most of these studies the focus has been on the Na⁺ accumulation/exclusion from the shoots [46,47], but also on the tolerance to high internal levels of Na⁺, commonly known as tissue tolerance [48,49].

Working with tomato, Saeed et al. referred that accessions showing lower accumulation of Na^+ and higher Na^+/K^+ ratios were those showing higher tolerance to salinity stress [24]. On the other hand, a study performed with two tomato cultivars tolerant to salinity showed that both cultivars displayed opposite responses when treated with NaCl [50]. Whereas the tolerance observed in the cultivar Pera was associated with a higher Na^+ and lower K^+ content in the shoot, in the cultivar GC-72 this same tolerance was associated with the retention of Na^+ in the root and restriction of translocation to the shoot [50]. Also in wheat the physiological differences in Na^+ exclusion, seen in different shoot or leaf Na^+ concentration, can be demonstrated although the relationship with salinity tolerance is not consistent [2].

In a study of the salinity tolerance of 349 *Arabidopsis thaliana* accessions a large variability in the leaf Na^+ accumulation was observed [40]. A Genome Wide Association (GWA) study performed on a subset of 337 *Arabidopsis accessions* revealed an SNP associated with leaf Na^+ accumulation that centred on *AtHKT1;1* [40]. Accessions with a T at position *Chr4:6392276* showed high foliar accumulation of Na^+ but also higher salinity tolerance, whereas accessions with a C at this same position showed low foliar accumulation of Na^+ and reduced salinity tolerance [40]. Several studies done with different plant species revealed that HKT1;1 acts by unloading Na^+ from the xylem into the xylem parenchyma cells (XPC) in the roots [39,51-53]. In view of its function, HKT1;1 transporters can balance the accumulation of Na^+ in the shoots of plants during periods of salinity stress [35,54]. Due to this function, HKT1;1 transporters are also responsible for the differences in Na^+ accumulation observed in the stems and leaves of plants. Although a consensus exists regarding the fact that HKT1;1 transporters are not involved in K^+ transport, some results still need to be clarified as a K^+ uptake *E. coli* mutant cells, expressing *AtHKT1;1*, grew in the presence of low concentrations of K^+ [39].

In this study, and based on the fact that Na^+ exclusion from the leaves is not always correlated with salinity tolerance [2,50,55], we decided to test 93 different tomato accessions (Table 2). These accessions were treated with 100 mM NaCl during two weeks in order to select a group of 24 accessions, based mainly on their Na^+ accumulation in the leaves but also on the K^+ accumulations in the leaves in some accessions. These genotypes were a selection of different species originated over a broad area of South America and the Galapagos Islands, and are representative for the range of genetic material that has been used in salinity studies. After measuring Na^+ and K^+ concentrations in the three tissues analysed, accessions were grouped by species, with those accumulating more Na^+ in the leaves ranking first. Interestingly, Na^+ and K^+ concentration in the stems of the majority of the accessions

analysed were higher than in roots and leaves what shows that tomato plants favour the accumulation of these ions in this tissue [55,56].

The ability of excluding Na^+ from the photosynthetic tissues has been associated with salt tolerance in monocotyledonous plants [5], although a report by Genc et al. [2] showed that the salt tolerance of several bread wheat genotypes did not correlate with Na^+ exclusion [2]. Dicotyledonous species show a broad variation between the tissue levels of Na^+ and salinity tolerance [6]. Villalta et al. reported that in both *S. pimpinellifolium* and *S. cheesmaniae* the tolerant phenotype lacked correlation with lower Na^+ concentrations in the leaf and stem as compared with those in the less salt tolerant *S. lycopersicum* [7]. Also in tomato, as previously referred, the accumulation of Na^+ in the leaves does not always correlate with salinity sensitivity [50,55]. In general, the wild tomato species are more salt tolerant than the cultivated ones where this trait is related to enhanced accumulation of Na^+ in the above-ground parts [56]. For example, the wild tomato genotype *S. pimpinellifolium* “PI365697” is significantly more salt tolerant than the *S. lycopersicum* “Moneymaker” cultivar. The “PI365697” genotype displays a lower inhibition of growth and a higher survival rate at the vegetative stage [23]. Due to this higher salinity tolerance shown by wild tomato species, it was proposed to use the wild species as donors of genes in breeding programs [56]. In order to find the most suitable mechanism to improve the salinity tolerance of tomato, the closely related wild species showing high salinity tolerance might be the of choice [23].

In view of the variation in Na^+ accumulation observed in all tissues analysed and the fact that Na^+ exclusion from the shoots *per se* does not seem to confer salinity tolerance to tomato plants, we decided to select tomato accessions within the same species showing the most contrasting Na^+ accumulation in the leaves for further analysis. The selected 24 accessions will be used in a new experiment (see Chapter 3), in which plants will be submitted to the same treatment as applied here, but a more in depth analysis, studying growth effects in combination with the analysis of other biochemical and molecular parameters, will be done. This experiment may give more insight into the mechanisms that tomato plants from different origin have developed to adapt to grow under saline conditions. These mechanisms may be further developed and used as markers for breeding efforts to improve salt tolerance of commercial tomato varieties.

Supplemental Information

Table S1: Na⁺ and K⁺ concentration and Na⁺/K⁺ ratio measured in the (A) leaves, (B) in the stems and (C) in the roots of salt treated tomato plants. Tomato accessions are grouped by species. The order within species was determined by the Na⁺ accumulation in the leaves; accessions accumulating more Na⁺ rank higher within a species group.

A)

Accession Number	Accession	Na ⁺		K ⁺		Na ⁺ /K ⁺	
		Mean	SE	Mean	SE	Mean	Se
1	Arbasson F1	0.86	0.02	1.54	0.00	0.56	0.02
2	Elpida F1	0.91	0.00	1.25	0.02	0.72	0.01
3	Estrella F1	0.94	0.02	1.54	0.02	0.61	0.02
4	Hybrid	0.89	0.00	1.31	0.01	0.68	0.00
4	Hybrid	0.88	0.01	1.10	0.01	0.80	0.01
5	Newton F1	0.80	0.03	0.92	0.01	0.87	0.03
34	LA 0531	1.22	0.03	1.53	0.03	0.80	0.02
22	LA 1412	1.18	0.02	1.51	0.01	0.78	0.01
19	LA 1959	1.86	0.02	0.95	0.01	1.96	0.05
8	LA 2774	1.70	0.02	0.86	0.02	1.98	0.06
86	LA 2880	1.50	0.01	1.42	0.03	1.06	0.03
67	LA 2750	1.43	0.03	1.22	0.02	1.17	0.02
37	LA 1961	1.42	0.03	1.39	0.02	1.02	0.03
38	LA 2747	1.39	0.00	1.42	0.01	0.97	0.00
79	LA 1930	1.38	0.02	1.41	0.04	0.97	0.02
52	LA 2981A	1.33	0.02	1.38	0.02	0.96	0.02
61	LA 1965	1.32	0.01	1.07	0.02	1.23	0.01
75	LA 2773	1.28	0.03	1.42	0.01	0.90	0.03
69	LA 2879	1.26	0.03	1.26	0.03	1.00	0.01
70	LA 2931	1.24	0.03	1.20	0.02	1.03	0.01
66	LA 2748	1.24	0.01	1.28	0.03	0.97	0.02
62	LA 1971	1.23	0.02	1.28	0.01	0.96	0.02
18	LA 1938	0.96	0.11	1.43	0.02	0.67	0.09
29	LA 1325	1.20	0.02	1.32	0.03	0.91	0.03
15	LA 1028	1.04	0.03	1.30	0.01	0.80	0.03
26	LA 1306	0.81	0.02	1.29	0.01	0.63	0.01
30	LA 2639B	0.79	0.01	1.63	0.01	0.49	0.01
32	LA 2681	0.75	0.02	1.34	0.01	0.56	0.02
16	LA 1316	0.68	0.01	1.32	0.02	0.51	0.01
31	LA 2678	0.63	0.02	1.61	0.02	0.39	0.01
33	LA 2695	0.63	0.02	1.02	0.02	0.61	0.03
17	GI 568	1.51	0.02	1.09	0.03	1.38	0.04
13	PI 126440	1.46	0.03	1.37	0.01	1.06	0.03
43	PI 126443	1.31	0.01	1.21	0.01	1.09	0.01
35	LA 0532	1.57	0.03	1.42	0.03	1.10	0.01
14	LA 1401	1.38	0.02	1.56	0.00	0.89	0.01
21	LA 1508	1.24	0.01	1.44	0.01	0.87	0.01
36	LA 0317	1.18	0.01	1.10	0.03	1.08	0.03
6	G 1560	1.69	0.01	1.03	0.01	1.63	0.02
83	LA 1393	1.40	0.03	1.14	0.00	1.23	0.02
12	PI 247087	1.33	0.03	1.09	0.01	1.22	0.04

42	LA 1363	1.27	0.03	1.08	0.02	1.18	0.02
49	LA 1033	1.27	0.02	1.19	0.02	1.07	0.02
63	LA 2167	0.86	0.01	1.25	0.02	0.69	0.02
60	LA 1624	1.47	0.01	1.41	0.00	1.05	0.00
73	PI 126449	1.43	0.01	1.01	0.00	1.42	0.01
46	PI 134417	1.43	0.00	1.32	0.01	1.08	0.01
72	CGN 15879	1.21	0.01	1.14	0.02	1.07	0.03
68	LA 2860	0.85	0.02	1.28	0.01	0.66	0.02
39	LA 3320	1.27	0.02	1.12	0.02	1.13	0.02
40	LA 2662	1.24	0.02	1.31	0.01	0.95	0.02
90	EZ 4	1.15	0.01	1.53	0.01	0.76	0.00
89	EZ 3	1.09	0.01	1.70	0.01	0.64	0.01
92	EZ 6	1.06	0.00	1.53	0.02	0.69	0.01
93	EZ 7	1.01	0.02	1.36	0.01	0.74	0.01
87	EZ 1	0.92	0.01	1.34	0.01	0.69	0.01
41	LA 3120	0.92	0.03	1.08	0.01	0.85	0.03
56	EZ 8	0.91	0.02	1.42	0.03	0.64	0.01
91	EZ 5	0.76	0.00	1.12	0.02	0.68	0.01
80	LA 2711	0.76	0.01	1.70	0.02	0.45	0.01
88	EZ 2	0.74	0.01	1.62	0.01	0.46	0.00
55	Daniela F1	0.66	0.02	1.46	0.02	0.45	0.02
54	Abigail F1	0.60	0.03	1.54	0.01	0.39	0.02
82	LA 1310	1.25	0.02	1.43	0.02	0.88	0.03
85	LA 2874	1.21	0.03	1.48	0.01	0.82	0.02
47	CGN 19145	0.80	0.03	1.44	0.01	0.56	0.02
9	LA 0247	1.32	0.00	1.18	0.00	1.12	0.01
27	LA 2917	1.25	0.00	1.25	0.01	1.01	0.01
28	LA 1319	1.23	0.02	0.74	0.01	1.65	0.04
71	964750062	1.10	0.03	1.21	0.02	0.91	0.01
7	LA 2194	0.89	0.02	1.35	0.01	0.66	0.02
59	LA 1522	1.49	0.02	1.47	0.01	1.01	0.01
65	LA 2560	1.45	0.02	1.61	0.02	0.90	0.01
58	LA 1340	1.36	0.01	1.63	0.01	0.83	0.00
57	LA 1302	1.93	0.01	1.53	0.00	1.26	0.01
64	LA 2548	1.71	0.01	1.22	0.02	1.40	0.02
77	LA 0462	1.58	0.03	1.13	0.01	1.40	0.03
20	PI 128659	1.57	0.02	1.36	0.01	1.15	0.01
11	PI 128653	1.55	0.02	1.27	0.02	1.23	0.03
48	LA 2744	1.45	0.02	1.09	0.01	1.33	0.02
76	PI 126435	1.40	0.02	1.25	0.01	1.12	0.02
74	LA 1910	1.38	0.02	1.21	0.02	1.14	0.01
81	LA 1278	1.29	0.03	1.33	0.01	0.97	0.01
51	PI 126935	1.22	0.01	1.23	0.04	1.00	0.03
78	LA 3218	1.18	0.01	1.94	0.02	0.61	0.01
84	LA 1579	1.49	0.02	1.29	0.01	1.16	0.02
45	PI 407546	1.46	0.02	1.28	0.01	1.14	0.01
24	LA 1259	1.41	0.01	1.41	0.01	1.00	0.00
44	PI 407543	1.40	0.02	1.19	0.02	1.18	0.03
25	LA 1243	1.37	0.01	1.42	0.02	0.96	0.02
50	LA 1223	1.37	0.02	1.22	0.01	1.12	0.03
53	LA 1245	1.32	0.01	1.19	0.01	1.11	0.01
23	LA 1248	0.83	0.01	1.41	0.02	0.59	0.02
10	OT 2209	0.62	0.01	1.42	0.01	0.44	0.01

Table S1: continuation.

B)

Accession Number	Accession	Na ⁺		K ⁺		Na ⁺ /K ⁺	
		Mean	SE	Mean	SE	Mean	SE
1	Arbasson F1	1.91	0.03	2.07	0.03	0.93	0.02
2	Elpida F1	1.57	0.02	1.63	0.01	0.96	0.01
3	Estrella F1	2.26	0.04	1.95	0.01	1.16	0.03
4	Hybrid	1.31	0.00	1.50	0.01	0.87	0.01
4	Hybrid	1.94	0.01	1.91	0.01	1.02	0.01
5	Newton F1	1.86	0.06	0.81	0.41	1.51	0.06
34	LA 0531	2.81	0.01	1.86	0.02	1.51	0.02
22	LA 1412	2.61	0.03	1.90	0.01	1.38	0.01
19	LA 1959	3.60	0.01	2.11	0.04	1.71	0.03
8	LA 2774	2.75	0.01	2.40	0.04	1.14	0.02
86	LA 2880	3.34	0.03	1.68	0.01	1.99	0.03
67	LA 2750	3.17	0.03	1.61	0.02	1.97	0.04
37	LA 1961	3.25	0.02	1.94	0.00	1.68	0.01
38	LA 2747	2.29	0.01	1.81	0.01	1.27	0.01
79	LA 1930	2.83	0.03	1.98	0.01	1.43	0.02
52	LA 2981A	2.23	0.02	1.77	0.03	1.26	0.02
61	LA 1965	2.64	0.03	1.77	0.03	1.49	0.02
75	LA 2773	2.43	0.02	1.91	0.01	1.27	0.02
69	LA 2879	2.02	0.02	1.89	0.02	1.07	0.01
70	LA 2931	2.34	0.04	1.78	0.03	1.31	0.02
66	LA 2748	2.52	0.03	1.79	0.03	1.41	0.03
62	LA 1971	2.92	0.01	1.73	0.03	1.69	0.03
18	LA 1938	3.30	0.02	1.83	0.03	1.80	0.02
29	LA 1325	2.09	0.02	2.45	0.02	0.85	0.00
15	LA 1028	1.95	0.02	1.04	0.02	1.87	0.05
26	LA 1306	1.35	0.03	1.71	0.02	0.79	0.02
30	LA 2639B	1.91	0.01	2.12	0.02	0.90	0.01
32	LA 2681	1.80	0.04	1.97	0.02	0.92	0.01
16	LA 1316	1.75	0.04	2.38	0.03	0.74	0.03
31	LA 2678	1.81	0.00	1.94	0.02	0.93	0.01
33	LA 2695	1.76	0.02	2.92	0.01	0.61	0.01
17	GI 568	2.41	0.03	1.69	0.01	1.43	0.02
13	PI 126440	2.62	0.05	1.88	0.02	1.39	0.03
43	PI 126443	2.41	0.03	1.75	0.01	1.38	0.01
35	LA 0532	2.62	0.01	1.44	0.03	1.82	0.05
14	LA 1401	2.29	0.01	1.64	0.01	1.40	0.01
21	LA 1508	2.41	0.05	2.55	0.06	0.94	0.00
36	LA 0317	2.38	0.05	1.59	0.01	1.50	0.03
6	G 1560	2.47	0.00	2.56	0.00	0.96	0.00
83	LA 1393	2.80	0.01	2.69	0.05	1.04	0.01
12	PI 247087	1.76	0.01	1.90	0.02	0.93	0.01
42	LA 1363	2.47	0.00	1.98	0.03	1.25	0.02
49	LA 1033	2.57	0.03	2.44	0.02	1.06	0.01
63	LA 2167	1.40	0.02	2.30	0.03	0.61	0.00
60	LA 1624	2.48	0.03	2.37	0.03	1.05	0.00
73	PI 126449	2.66	0.03	2.12	0.02	1.26	0.01

46	PI 134417	1.98	0.03	2.14	0.04	0.92	0.03
72	CGN 15879	1.73	0.02	2.10	0.03	0.83	0.02
68	LA 2860	1.22	0.01	2.12	0.02	0.57	0.00
39	LA 3320	2.06	0.03	2.07	0.02	1.00	0.01
40	LA 2662	1.74	0.02	0.97	0.01	1.79	0.04
90	EZ 4	2.43	0.01	1.84	0.02	1.33	0.01
89	EZ 3	2.06	0.02	0.96	0.00	2.15	0.02
92	EZ 6	2.71	0.01	2.24	0.03	1.21	0.02
93	EZ 7	1.78	0.02	1.86	0.01	0.95	0.01
87	EZ 1	2.44	0.03	1.89	0.01	1.29	0.03
41	LA 3120	1.60	0.00	2.26	0.04	0.71	0.01
56	EZ 8	2.25	0.01	2.05	0.03	1.10	0.02
91	EZ 5	1.96	0.02	1.43	0.02	1.37	0.03
80	LA 2711	2.04	0.01	2.13	0.02	0.96	0.01
88	EZ 2	1.91	0.02	2.27	0.03	0.84	0.01
55	Daniela F1	1.92	0.01	2.11	0.03	0.91	0.01
54	Abigail F1	2.14	0.02	2.14	0.02	1.00	0.01
82	LA 1310	2.51	0.03	2.08	0.04	1.21	0.04
85	LA 2874	2.21	0.03	2.20	0.03	1.00	0.00
47	CGN 19145	1.63	0.02	2.25	0.02	0.72	0.00
9	LA 0247	1.89	0.04	2.45	0.01	0.77	0.02
27	LA 2917	2.08	0.03	1.37	0.01	1.52	0.04
28	LA 1319	1.84	0.02	1.43	0.02	1.29	0.03
71	964750062	1.57	0.01	2.19	0.02	0.72	0.01
7	LA 2194	1.40	0.01	2.83	0.01	0.50	0.01
59	LA 1522	3.92	0.02	1.95	0.03	2.01	0.04
65	LA 2560	3.79	0.02	2.25	0.02	1.69	0.01
58	LA 1340	3.75	0.01	1.16	0.02	3.23	0.04
57	LA 1302	4.46	0.02	2.32	0.01	1.92	0.00
64	LA 2548	2.92	0.02	2.05	0.01	1.43	0.02
77	LA 0462	2.92	0.03	1.77	0.03	1.65	0.01
20	PI 128659	2.67	0.03	1.26	0.01	2.13	0.04
11	PI 128653	2.71	0.00	1.69	0.02	1.60	0.02
48	LA 2744	2.33	0.01	1.54	0.02	1.51	0.02
76	PI 126435	2.18	0.02	1.61	0.03	1.36	0.01
74	LA 1910	2.04	0.01	1.56	0.02	1.31	0.01
81	LA 1278	2.54	0.02	1.90	0.02	1.34	0.01
51	PI 126935	2.39	0.04	1.39	0.03	1.72	0.00
78	LA 3218	2.49	0.02	1.65	0.00	1.51	0.01
84	LA 1579	2.45	0.02	1.95	0.03	1.26	0.02
45	PI 407546	2.41	0.03	2.19	0.01	1.10	0.02
24	LA 1259	2.60	0.04	2.10	0.03	1.24	0.03
44	PI 407543	2.41	0.02	1.73	0.03	1.39	0.03
25	LA 1243	1.63	0.02	1.81	0.00	0.90	0.01
50	LA 1223	3.03	0.02	1.93	0.02	1.57	0.02
53	LA 1245	2.87	0.02	1.92	0.01	1.49	0.02
23	LA 1248	2.04	0.01	2.08	0.03	0.98	0.01
10	OT 2209	1.52	0.01	1.72	0.02	0.88	0.02

Table S1: continuation.

C)

Accession Number	Accession	Na ⁺		K ⁺		Na ⁺ /K ⁺	
		Mean	SE	Mean	SE	Mean	SE
1	Arbasson F1	2.04	0.02	0.86	0.01	2.38	0.05
2	Elpida F1	1.98	0.08	1.44	0.02	1.37	0.08
3	Estrella F1	1.86	0.07	0.91	0.02	2.05	0.11
4	Hybrid	2.10	0.01	1.34	0.00	1.56	0.01
4	Hybrid	2.06	0.01	1.45	0.01	1.42	0.01
5	Newton F1	1.88	0.04	1.06	0.02	1.77	0.04
34	LA 0531	1.67	0.03	0.89	0.02	1.87	0.06
22	LA 1412	1.41	0.05	1.20	0.04	1.17	0.01
19	LA 1959	2.43	0.01	1.26	0.01	1.92	0.02
8	LA 2774	1.75	0.03	1.80	0.01	0.97	0.01
86	LA 2880	2.01	0.01	1.09	0.02	1.85	0.04
67	LA 2750	2.11	0.05	1.41	0.02	1.50	0.05
37	LA 1961	1.81	0.02	0.96	0.02	1.88	0.03
38	LA 2747	1.72	0.02	1.13	0.01	1.52	0.02
79	LA 1930	1.65	0.01	1.24	0.00	1.33	0.01
52	LA 2981A	1.41	0.03	1.17	0.02	1.21	0.03
61	LA 1965	1.55	0.02	0.98	0.02	1.59	0.05
75	LA 2773	1.42	0.02	1.45	0.02	0.98	0.01
69	LA 2879	1.32	0.02	1.23	0.01	1.07	0.02
70	LA 2931	1.39	0.02	1.31	0.00	1.06	0.01
66	LA 2748	1.24	0.03	1.08	0.01	1.16	0.03
62	LA 1971	1.46	0.03	1.15	0.02	1.27	0.02
18	LA 1938	1.50	0.05	1.16	0.00	1.29	0.04
29	LA 1325	2.20	0.04	1.24	0.01	1.77	0.04
15	LA 1028	2.15	0.03	1.73	0.02	1.24	0.02
26	LA 1306	1.88	0.02	1.30	0.01	1.44	0.01
30	LA 2639B	2.01	0.01	0.88	0.02	2.28	0.05
32	LA 2681	1.75	0.02	0.92	0.02	1.91	0.06
16	LA 1316	2.36	0.03	1.09	0.02	2.16	0.02
31	LA 2678	2.05	0.03	1.47	0.02	1.40	0.03
33	LA 2695	1.96	0.01	1.58	0.02	1.25	0.01
17	GI 568	1.43	0.03	1.09	0.03	1.32	0.06
13	PI 126440	1.42	0.02	1.20	0.01	1.18	0.02
43	PI 126443	1.29	0.01	1.07	0.01	1.22	0.02
35	LA 0532	2.24	0.03	1.34	0.02	1.67	0.04
14	LA 1401	2.07	0.00	1.54	0.00	1.34	0.00
21	LA 1508	2.09	0.04	1.41	0.01	1.48	0.01
36	LA 0317	1.69	0.03	1.22	0.01	1.38	0.03
6	G 1560	1.36	0.02	1.26	0.01	1.08	0.01
83	LA 1393	1.69	0.01	1.13	0.01	1.50	0.02
12	PI 247087	1.86	0.01	1.44	0.02	1.29	0.03
42	LA 1363	1.84	0.02	1.33	0.03	1.39	0.05
49	LA 1033	1.12	0.01	1.18	0.01	0.95	0.00
63	LA 2167	1.72	0.02	1.11	0.00	1.55	0.02
60	LA 1624	1.72	0.04	1.02	0.01	1.68	0.06
73	PI 126449	2.42	0.02	1.28	0.02	1.89	0.01
46	PI 134417	1.38	0.02	1.23	0.02	1.13	0.00

72	CGN 15879	1.56	0.01	1.36	0.01	1.15	0.02
68	LA 2860	1.40	0.02	1.27	0.02	1.10	0.01
39	LA 3320	1.69	0.02	0.90	0.01	1.87	0.02
40	LA 2662	2.16	0.03	1.20	0.01	1.81	0.02
90	EZ 4	1.65	0.02	1.38	0.01	1.19	0.00
89	EZ 3	1.59	0.02	1.53	0.01	1.04	0.02
92	EZ 6	1.60	0.01	0.79	0.01	2.03	0.04
93	EZ 7	1.30	0.02	1.21	0.01	1.08	0.02
87	EZ 1	1.91	0.00	1.21	0.00	1.58	0.01
41	LA 3120	2.38	0.02	1.25	0.02	1.90	0.04
56	EZ 8	1.83	0.03	1.41	0.01	1.30	0.02
91	EZ 5	1.93	0.03	1.26	0.02	1.53	0.04
80	LA 2711	1.70	0.03	0.85	0.02	2.00	0.01
88	EZ 2	1.69	0.01	1.07	0.02	1.58	0.04
55	Daniela F1	1.74	0.02	1.51	0.02	1.15	0.02
54	Abigail F1	1.55	0.02	0.85	0.00	1.82	0.02
82	LA 1310	0.94	0.02	1.14	0.01	0.82	0.02
85	LA 2874	1.11	0.01	1.23	0.02	0.90	0.01
47	CGN 19145	1.07	0.01	0.73	0.01	1.45	0.01
9	LA 0247	1.69	0.02	0.86	0.00	1.97	0.02
27	LA 2917	1.78	0.03	0.65	0.00	2.76	0.04
28	LA 1319	1.43	0.02	0.65	0.02	2.19	0.09
71	964750062	1.40	0.01	1.11	0.02	1.26	0.03
7	LA 2194	1.99	0.01	0.98	0.03	2.04	0.07
59	LA 1522	1.19	0.02	1.40	0.04	0.85	0.04
65	LA 2560	1.31	0.02	1.37	0.02	0.95	0.03
58	LA 1340	1.87	0.00	2.08	0.02	0.90	0.01
57	LA 1302	1.53	0.01	1.57	0.01	0.98	0.00
64	LA 2548	2.06	0.02	1.21	0.01	1.71	0.02
77	LA 0462	1.68	0.00	1.09	0.03	1.54	0.04
20	PI 128659	2.04	0.03	1.40	0.02	1.46	0.03
11	PI 128653	2.18	0.03	1.37	0.01	1.58	0.01
48	LA 2744	1.92	0.03	1.44	0.01	1.33	0.03
76	PI 126435	1.97	0.02	0.77	0.02	2.57	0.07
74	LA 1910	1.38	0.03	1.50	0.02	0.92	0.01
81	LA 1278	1.77	0.02	1.15	0.00	1.54	0.02
51	PI 126935	2.07	0.01	1.23	0.02	1.68	0.04
78	LA 3218	1.99	0.01	1.17	0.02	1.70	0.02
84	LA 1579	1.47	0.02	1.05	0.01	1.41	0.03
45	PI 407546	1.50	0.01	1.24	0.02	1.22	0.02
24	LA 1259	1.33	0.02	1.22	0.01	1.09	0.02
44	PI 407543	1.45	0.03	1.23	0.02	1.18	0.04
25	LA 1243	1.63	0.02	1.25	0.01	1.30	0.02
50	LA 1223	1.73	0.02	1.17	0.01	1.48	0.03
53	LA 1245	1.42	0.02	1.11	0.02	1.28	0.04
23	LA 1248	1.44	0.03	1.49	0.01	0.97	0.03
10	OT 2209	1.76	0.02	1.27	0.02	1.38	0.04

Table S2: Na⁺ and K⁺ concentration and Na⁺/K⁺ ratio measured in the (A) leaves, (B) stems and (C) roots of control tomato plants. Tomato accessions are grouped by species. The order within species is according to the Na⁺ accumulation in the leaves of the salt treated plants shown on Table 1; accessions accumulating more Na⁺ rank higher within a species group.

A)

Accession Number	Accession	Na ⁺		K ⁺		Na ⁺ /K ⁺	
		Mean	SE	Mean	SE	Mean	SE
1	Arbasson F1	0.24	0.02	1.41	0.03	0.17	0.01
2	Elpida F1	0.42	0.03	1.52	0.09	0.28	0.03
3	Estrella F1	0.34	0.03	1.42	0.05	0.24	0.02
4	Hybrid	0.28	0.02	1.40	0.03	0.20	0.02
4	Hybrid	0.41	0.02	1.57	0.03	0.26	0.01
5	Newton F1	0.41	0.04	1.50	0.07	0.27	0.02
34	LA 0531	0.47	0.00	1.51	0.08	0.31	0.02
22	LA 1412	0.36	0.01	1.49	0.08	0.24	0.01
19	LA 1959	0.42	0.06	1.32	0.05	0.32	0.05
8	LA 2774	0.60	0.09	1.75	0.07	0.34	0.05
86	LA 2880	0.80	0.07	1.74	0.04	0.46	0.04
67	LA 2750	0.37	0.03	1.79	0.07	0.21	0.02
37	LA 1961	0.51	0.06	1.64	0.00	0.31	0.03
38	LA 2747	0.74	0.04	1.75	0.04	0.42	0.03
79	LA 1930	0.42	0.04	1.58	0.04	0.27	0.02
52	LA 2981A	0.33	0.04	1.38	0.01	0.24	0.03
61	LA 1965	0.53	0.07	1.42	0.02	0.37	0.04
75	LA 2773	0.40	0.05	1.54	0.04	0.26	0.03
69	LA 2879	0.46	0.07	1.50	0.04	0.31	0.05
70	LA 2931	0.44	0.04	1.60	0.06	0.28	0.02
66	LA 2748	0.39	0.04	1.47	0.08	0.27	0.03
62	LA 1971	0.38	0.02	1.41	0.07	0.27	0.02
18	LA 1938	0.36	0.03	1.57	0.05	0.23	0.02
29	LA 1325	0.42	0.09	1.84	0.03	0.23	0.05
15	LA 1028	0.30	0.12	1.60	0.08	0.19	0.07
26	LA 1306	0.44	0.03	1.66	0.04	0.27	0.01
30	LA 2639B	0.24	0.02	1.33	0.02	0.18	0.02
32	LA 2681	0.73	0.03	1.84	0.03	0.40	0.02
16	LA 1316	0.33	0.05	1.66	0.06	0.20	0.02
31	LA 2678	0.36	0.04	1.91	0.05	0.19	0.02
33	LA 2695	0.54	0.06	1.92	0.04	0.28	0.03
17	GI 568	0.62	0.04	1.34	0.07	0.46	0.01
13	PI 126440	0.49	0.03	1.27	0.03	0.38	0.02
43	PI 126443	0.57	0.05	1.31	0.03	0.44	0.03
35	LA 0532	0.59	0.02	1.64	0.01	0.36	0.01
14	LA 1401	0.46	0.05	1.53	0.02	0.30	0.03
21	LA 1508	0.35	0.02	1.54	0.01	0.23	0.01
36	LA 0317	0.45	0.01	1.60	0.05	0.28	0.02
6	G 1560	0.75	0.06	1.33	0.03	0.57	0.04
83	LA 1393	0.61	0.02	1.50	0.02	0.41	0.01
12	PI 247087	0.82	0.03	1.63	0.03	0.50	0.03
42	LA 1363	0.50	0.05	1.58	0.06	0.32	0.04
49	LA 1033	0.71	0.00	1.30	0.03	0.54	0.01

63	LA 2167	0.36	0.02	1.40	0.04	0.26	0.01
60	LA 1624	0.79	0.03	1.79	0.03	0.44	0.02
73	PI 126449	0.81	0.06	1.95	0.04	0.42	0.03
46	PI 134417	0.66	0.01	1.73	0.06	0.38	0.02
72	CGN 15879	0.53	0.04	2.03	0.05	0.26	0.03
68	LA 2860	0.29	0.04	1.65	0.05	0.17	0.02
39	LA 3320	0.54	0.04	1.54	0.01	0.35	0.03
40	LA 2662	0.54	0.07	1.61	0.01	0.33	0.04
90	EZ 4	0.40	0.01	1.39	0.03	0.29	0.02
89	EZ 3	0.45	0.02	1.53	0.02	0.29	0.01
92	EZ 6	0.44	0.02	2.01	0.04	0.22	0.01
93	EZ 7	0.35	0.03	1.46	0.03	0.24	0.02
87	EZ 1	0.50	0.02	1.54	0.02	0.32	0.02
41	LA 3120	0.37	0.01	1.35	0.02	0.27	0.01
56	EZ 8	0.34	0.04	1.49	0.06	0.23	0.02
91	EZ 5	0.34	0.02	1.62	0.04	0.21	0.01
80	LA 2711	0.39	0.02	1.56	0.06	0.25	0.01
88	EZ 2	0.32	0.02	1.55	0.01	0.20	0.01
55	Daniela F1	0.27	0.03	1.48	0.03	0.18	0.01
54	Abigail F1	0.36	0.03	1.44	0.04	0.25	0.02
82	LA 1310	0.44	0.05	1.44	0.02	0.30	0.04
85	LA 2874	0.47	0.03	1.61	0.03	0.29	0.01
47	CGN 19145	0.34	0.01	1.46	0.05	0.23	0.01
9	LA 0247	0.62	0.01	1.15	0.06	0.54	0.02
27	LA 2917	0.47	0.05	1.61	0.04	0.29	0.02
28	LA 1319	0.43	0.04	1.28	0.02	0.33	0.03
71	964750062	0.39	0.05	1.34	0.04	0.29	0.03
7	LA 2194	0.44	0.02	1.54	0.05	0.29	0.02
59	LA 1522	0.53	0.05	1.59	0.04	0.34	0.03
65	LA 2560	0.57	0.06	1.47	0.02	0.39	0.04
58	LA 1340	0.57	0.03	1.47	0.04	0.39	0.03
57	LA 1302	1.18	0.02	1.92	0.03	0.61	0.01
64	LA 2548	0.87	0.05	1.74	0.05	0.50	0.04
77	LA 0462	0.52	0.05	1.40	0.01	0.37	0.04
20	PI 128659	0.61	0.03	1.12	0.02	0.54	0.04
11	PI 128653	0.55	0.03	1.23	0.06	0.45	0.01
48	LA 2744	0.49	0.01	1.37	0.01	0.35	0.01
76	PI 126435	0.57	0.03	1.50	0.06	0.38	0.01
74	LA 1910	0.74	0.05	1.93	0.05	0.38	0.03
81	LA 1278	0.48	0.02	1.44	0.03	0.33	0.01
51	PI 126935	0.55	0.03	1.59	0.03	0.35	0.03
78	LA 3218	0.44	0.05	1.59	0.04	0.28	0.02
84	LA 1579	1.19	0.05	1.38	0.05	0.86	0.05
45	PI 407546	0.46	0.02	1.59	0.03	0.29	0.01
24	LA 1259	0.55	0.06	1.48	0.06	0.37	0.05
44	PI 407543	0.56	0.07	1.46	0.03	0.38	0.04
25	LA 1243	0.50	0.10	1.34	0.03	0.37	0.07
50	LA 1223	0.55	0.08	1.55	0.05	0.36	0.04
53	LA 1245	0.49	0.03	1.35	0.00	0.37	0.02
23	LA 1248	0.41	0.03	1.51	0.04	0.27	0.01
10	OT 2209	0.26	0.04	1.46	0.05	0.17	0.02

Table S2: continuation.

B)

Accession Number	Accession	Na ⁺		K ⁺		Na ⁺ /K ⁺	
		Mean	SE	Mean	SE	Mean	SE
1	Arbasson F1	0.79	0.02	2.46	0.01	0.32	0.01
2	Elpida F1	1.00	0.07	2.73	0.14	0.37	0.04
3	Estrella F1	1.06	0.06	2.64	0.09	0.40	0.04
4	Hybrid	0.80	0.02	2.19	0.07	0.37	0.02
4	Hybrid	0.92	0.02	3.00	0.04	0.31	0.01
5	Newton F1	0.85	0.05	2.57	0.04	0.33	0.02
34	LA 0531	0.89	0.05	2.34	0.06	0.38	0.01
22	LA 1412	0.98	0.01	2.32	0.03	0.42	0.00
19	LA 1959	1.14	0.04	2.24	0.06	0.51	0.02
8	LA 2774	1.35	0.08	3.31	0.08	0.41	0.01
86	LA 2880	1.08	0.13	2.59	0.07	0.42	0.06
67	LA 2750	1.50	0.05	2.88	0.07	0.52	0.01
37	LA 1961	1.34	0.11	2.81	0.06	0.48	0.03
38	LA 2747	1.18	0.03	2.58	0.04	0.46	0.01
79	LA 1930	0.96	0.08	2.39	0.01	0.40	0.03
52	LA 2981A	1.10	0.09	2.25	0.10	0.49	0.02
61	LA 1965	1.17	0.05	2.18	0.05	0.54	0.01
75	LA 2773	0.86	0.03	2.23	0.07	0.38	0.00
69	LA 2879	1.14	0.02	2.38	0.12	0.48	0.03
70	LA 2931	1.01	0.07	2.26	0.04	0.45	0.04
66	LA 2748	1.03	0.03	2.32	0.16	0.45	0.02
62	LA 1971	1.04	0.06	2.42	0.12	0.43	0.02
18	LA 1938	1.04	0.02	1.93	0.00	0.54	0.01
29	LA 1325	0.66	0.07	2.34	0.05	0.28	0.03
15	LA 1028	1.49	0.15	2.89	0.02	0.52	0.05
26	LA 1306	0.57	0.05	3.69	0.13	0.16	0.01
30	LA 2639B	0.50	0.06	1.56	0.03	0.32	0.04
32	LA 2681	0.84	0.06	2.99	0.14	0.28	0.03
16	LA 1316	0.43	0.08	2.96	0.03	0.15	0.03
31	LA 2678	0.59	0.03	2.65	0.05	0.22	0.01
33	LA 2695	0.55	0.06	3.37	0.00	0.16	0.02
17	GI 568	1.16	0.00	2.16	0.05	0.53	0.01
13	PI 126440	1.14	0.00	2.68	0.04	0.43	0.01
43	PI 126443	1.17	0.03	2.27	0.09	0.52	0.03
35	LA 0532	1.73	0.06	2.80	0.03	0.62	0.02
14	LA 1401	1.56	0.02	2.46	0.10	0.63	0.02
21	LA 1508	0.95	0.02	2.45	0.06	0.39	0.02
36	LA 0317	1.38	0.04	2.56	0.03	0.54	0.01
6	G 1560	1.20	0.02	2.86	0.11	0.42	0.01
83	LA 1393	1.08	0.05	2.78	1.11	0.45	0.25
12	PI 247087	0.70	0.02	3.33	0.05	0.21	0.00
42	LA 1363	1.21	0.07	2.58	0.08	0.47	0.04
49	LA 1033	1.10	0.02	2.54	0.05	0.43	0.03
63	LA 2167	0.76	0.03	2.39	0.06	0.32	0.00
60	LA 1624	0.77	0.03	3.17	0.08	0.24	0.01
73	PI 126449	1.34	0.02	2.67	0.04	0.50	0.01
46	PI 134417	1.22	0.05	2.28	0.05	0.53	0.01

72	CGN 15879	1.01	0.04	3.21	0.02	0.31	0.01
68	LA 2860	0.42	0.06	2.39	0.16	0.18	0.03
39	LA 3320	0.93	0.05	2.45	0.11	0.38	0.04
40	LA 2662	0.79	0.05	2.63	0.07	0.30	0.02
90	EZ 4	0.87	0.01	2.72	0.03	0.32	0.00
89	EZ 3	1.07	0.02	1.78	0.01	0.60	0.01
92	EZ 6	1.10	0.01	2.87	0.03	0.38	0.01
93	EZ 7	0.85	0.02	2.94	0.01	0.29	0.01
87	EZ 1	1.15	0.01	3.23	0.04	0.36	0.00
41	LA 3120	0.76	0.01	2.53	0.06	0.30	0.01
56	EZ 8	0.85	0.02	2.40	0.10	0.35	0.00
91	EZ 5	0.68	0.03	2.76	0.05	0.25	0.01
80	LA 2711	0.90	0.03	2.57	0.05	0.35	0.01
88	EZ 2	0.72	0.02	2.18	0.04	0.33	0.01
55	Daniela F1	0.86	0.06	2.63	0.09	0.33	0.02
54	Abigail F1	0.70	0.03	2.70	0.12	0.26	0.00
82	LA 1310	1.44	0.06	2.07	0.02	0.69	0.02
85	LA 2874	1.27	0.05	2.36	0.08	0.54	0.03
47	CGN 19145	0.68	0.06	2.15	0.05	0.32	0.03
9	LA 0247	1.14	0.07	2.32	0.04	0.49	0.03
27	LA 2917	0.57	0.06	2.80	0.02	0.20	0.02
28	LA 1319	0.79	0.05	2.98	0.01	0.26	0.01
71	964750062	0.60	0.02	2.46	0.04	0.25	0.00
7	LA 2194	0.64	0.03	2.72	0.03	0.24	0.01
59	LA 1522	1.65	0.00	2.92	0.01	0.57	0.00
65	LA 2560	1.63	0.07	2.74	0.01	0.59	0.02
58	LA 1340	1.55	0.01	2.69	0.01	0.58	0.01
57	LA 1302	1.76	0.02	2.94	0.04	0.60	0.01
64	LA 2548	1.07	0.07	2.53	0.09	0.42	0.04
77	LA 0462	1.04	0.05	2.26	0.05	0.46	0.02
20	PI 128659	1.12	0.03	1.99	0.03	0.56	0.01
11	PI 128653	1.09	0.03	2.03	0.05	0.54	0.00
48	LA 2744	1.11	0.02	2.05	0.00	0.54	0.01
76	PI 126435	1.28	0.02	2.59	0.07	0.49	0.00
74	LA 1910	0.94	0.08	2.42	0.03	0.39	0.03
81	LA 1278	1.55	0.07	2.08	0.07	0.75	0.02
51	PI 126935	0.85	0.06	2.04	0.06	0.42	0.02
78	LA 3218	1.13	0.07	3.04	0.03	0.37	0.03
84	LA 1579	1.39	0.03	2.73	0.11	0.51	0.01
45	PI 407546	1.28	0.03	2.30	0.04	0.56	0.02
24	LA 1259	1.37	0.06	2.83	0.06	0.48	0.03
44	PI 407543	1.20	0.03	2.47	0.07	0.48	0.00
25	LA 1243	0.78	0.03	2.75	0.03	0.28	0.01
50	LA 1223	1.66	0.01	1.80	0.01	0.92	0.01
53	LA 1245	1.46	0.05	2.49	0.05	0.59	0.03
23	LA 1248	1.08	0.02	2.41	0.07	0.45	0.02
10	OT 2209	0.78	0.04	2.02	0.03	0.39	0.03

Table S2: continuation.

C)

Accession Number	Accession	Na ⁺		K ⁺		Na ⁺ /K ⁺	
		Mean	SE	Mean	SE	Mean	SE
1	Arbasson F1	0.77	0.06	1.20	0.03	0.64	0.03
2	Elpida F1	0.81	0.05	1.22	0.06	0.66	0.04
3	Estrella F1	0.71	0.01	1.24	0.02	0.57	0.02
4	Hybrid	0.56	0.01	1.28	0.01	0.44	0.01
4	Hybrid	0.89	0.00	1.24	0.02	0.72	0.01
5	Newton F1	0.86	0.05	1.36	0.06	0.63	0.01
34	LA 0531	1.13	0.06	1.75	0.05	0.65	0.05
22	LA 1412	0.97	0.01	1.73	0.08	0.56	0.03
19	LA 1959	0.76	0.05	1.28	0.02	0.60	0.05
8	LA 2774	0.79	0.01	1.15	0.01	0.69	0.02
86	LA 2880	1.01	0.04	1.84	0.04	0.55	0.02
67	LA 2750	1.31	0.10	1.80	0.09	0.73	0.03
37	LA 1961	1.26	0.04	1.04	0.03	1.21	0.07
38	LA 2747	0.78	0.02	1.33	0.03	0.58	0.02
79	LA 1930	0.51	0.03	1.41	0.07	0.37	0.04
52	LA 2981A	0.52	0.01	1.04	0.02	0.50	0.01
61	LA 1965	1.06	0.03	1.38	0.07	0.77	0.04
75	LA 2773	0.53	0.03	1.50	0.05	0.35	0.03
69	LA 2879	0.67	0.06	1.42	0.08	0.47	0.02
70	LA 2931	0.50	0.04	1.39	0.07	0.36	0.03
66	LA 2748	0.58	0.08	1.23	0.02	0.48	0.07
62	LA 1971	0.49	0.01	1.03	0.04	0.47	0.03
18	LA 1938	0.52	0.08	1.20	0.01	0.43	0.07
29	LA 1325	0.94	0.03	1.23	0.05	0.76	0.02
15	LA 1028	0.86	0.18	1.65	0.02	0.52	0.11
26	LA 1306	1.38	0.10	0.86	0.02	1.61	0.11
30	LA 2639B	1.04	0.06	1.58	0.01	0.66	0.03
32	LA 2681	1.38	0.07	1.30	0.11	1.06	0.08
16	LA 1316	1.13	0.05	1.33	0.07	0.85	0.02
31	LA 2678	1.45	0.05	1.90	0.06	0.76	0.03
33	LA 2695	1.17	0.00	1.16	0.21	1.02	0.18
17	GI 568	0.57	0.03	1.27	0.04	0.45	0.01
13	PI 126440	0.43	0.00	1.39	0.06	0.31	0.01
43	PI 126443	0.38	0.02	1.05	0.03	0.36	0.03
35	LA 0532	1.15	0.06	1.51	0.04	0.76	0.02
14	LA 1401	0.53	0.02	2.17	0.06	0.25	0.00
21	LA 1508	0.46	0.06	1.67	0.02	0.28	0.04
36	LA 0317	0.76	0.06	1.75	0.07	0.43	0.02
6	G 1560	0.61	0.05	1.28	0.03	0.48	0.05
83	LA 1393	0.96	0.05	1.32	0.06	0.73	0.01
12	PI 247087	1.00	0.04	1.55	0.00	0.65	0.02
42	LA 1363	0.77	0.05	1.50	0.03	0.51	0.05
49	LA 1033	0.56	0.02	1.16	0.04	0.49	0.03
63	LA 2167	0.85	0.00	1.21	0.07	0.70	0.04
60	LA 1624	1.39	0.08	1.94	0.02	0.71	0.04
73	PI 126449	0.95	0.06	1.68	0.02	0.57	0.03
46	PI 134417	0.56	0.04	1.73	0.04	0.32	0.01

72	CGN 15879	1.02	0.02	2.07	0.03	0.49	0.01
68	LA 2860	0.89	0.07	1.73	0.04	0.51	0.03
39	LA 3320	0.50	0.08	1.17	0.04	0.42	0.06
40	LA 2662	0.85	0.06	1.24	0.04	0.69	0.04
90	EZ 4	0.81	0.01	1.41	0.02	0.58	0.01
89	EZ 3	0.85	0.02	1.29	0.01	0.66	0.02
92	EZ 6	0.83	0.01	1.66	0.02	0.50	0.00
93	EZ 7	0.80	0.00	1.74	0.02	0.46	0.01
87	EZ 1	0.96	0.02	1.54	0.01	0.62	0.02
41	LA 3120	0.77	0.05	1.49	0.04	0.52	0.04
56	EZ 8	1.11	0.04	1.52	0.03	0.73	0.04
91	EZ 5	0.69	0.02	1.37	0.02	0.51	0.01
80	LA 2711	0.58	0.05	1.10	0.01	0.53	0.05
88	EZ 2	0.72	0.02	1.46	0.02	0.49	0.01
55	Daniela F1	0.73	0.05	1.48	0.03	0.50	0.04
54	Abigail F1	0.56	0.01	1.46	0.04	0.38	0.02
82	LA 1310	0.48	0.07	1.45	0.08	0.34	0.05
85	LA 2874	0.53	0.04	1.27	0.01	0.41	0.03
47	CGN 19145	0.49	0.05	1.48	0.02	0.33	0.03
9	LA 0247	1.23	0.04	1.22	0.02	1.01	0.01
27	LA 2917	1.39	0.01	1.47	0.05	0.95	0.03
28	LA 1319	1.40	0.04	1.30	0.01	1.07	0.03
71	964750062	1.19	0.02	1.56	0.02	0.76	0.02
7	LA 2194	0.89	0.07	1.56	0.04	0.57	0.03
59	LA 1522	0.69	0.02	1.81	0.06	0.38	0.01
65	LA 2560	0.78	0.01	1.42	0.05	0.55	0.01
58	LA 1340	0.52	0.02	1.44	0.05	0.36	0.02
57	LA 1302	1.42	0.18	1.79	0.03	0.80	0.11
64	LA 2548	0.91	0.06	1.39	0.05	0.65	0.04
77	LA 0462	1.20	0.03	1.35	0.02	0.89	0.03
20	PI 128659	0.50	0.05	1.20	0.01	0.42	0.04
11	PI 128653	0.46	0.03	1.05	0.06	0.44	0.05
48	LA 2744	0.54	0.04	1.21	0.02	0.45	0.03
76	PI 126435	0.68	0.06	1.52	0.02	0.45	0.04
74	LA 1910	0.83	0.06	1.68	0.04	0.49	0.02
81	LA 1278	0.68	0.02	1.57	0.02	0.43	0.02
51	PI 126935	0.47	0.04	1.43	0.05	0.33	0.04
78	LA 3218	0.68	0.01	1.56	0.06	0.44	0.01
84	LA 1579	1.15	0.05	1.41	0.01	0.82	0.04
45	PI 407546	0.54	0.06	1.44	0.02	0.38	0.04
24	LA 1259	0.74	0.07	1.46	0.07	0.51	0.04
44	PI 407543	0.41	0.04	1.08	0.04	0.38	0.04
25	LA 1243	0.60	0.02	1.36	0.02	0.44	0.01
50	LA 1223	0.47	0.03	0.94	0.04	0.50	0.05
53	LA 1245	0.53	0.02	1.21	0.02	0.43	0.02
23	LA 1248	0.74	0.05	1.39	0.05	0.53	0.03
10	OT 2209	0.46	0.05	1.20	0.02	0.38	0.04

Table S3: K^+ control/ K^+ salt in the three tissues analysed. The order within species is according to the Na^+ accumulation in the leaves of the salt treated plants shown on Table 1; accessions accumulating more Na^+ rank higher within a species group.

Accession Number	Accession	K^+ control/ K^+ salt		
		Leaves	Stems	Roots
1	Arbasson F1	0.92	1.19	1.40
2	Elpida F1	1.21	1.68	0.85
3	Estrella F1	0.92	1.35	1.37
4	Hybrid	1.06	1.46	0.95
4	Hybrid	1.43	1.57	0.85
5	Newton F1	1.62	3.17	1.28
34	LA 0531	0.98	1.26	1.95
22	LA 1412	0.99	1.22	1.44
19	LA 1959	1.39	1.06	1.01
8	LA 2774	2.04	1.38	0.64
86	LA 2880	1.23	1.54	1.69
67	LA 2750	1.46	1.79	1.28
37	LA 1961	1.18	1.45	1.08
38	LA 2747	1.23	1.42	1.18
79	LA 1930	1.12	1.20	1.14
52	LA 2981A	1.00	1.27	0.89
61	LA 1965	1.33	1.23	1.41
75	LA 2773	1.09	1.17	1.03
69	LA 2879	1.19	1.26	1.16
70	LA 2931	1.33	1.27	1.06
66	LA 2748	1.15	1.29	1.14
62	LA 1971	1.10	1.40	0.89
18	LA 1938	1.10	1.06	1.03
29	LA 1325	1.40	0.95	0.99
15	LA 1028	1.23	2.78	0.95
26	LA 1306	1.29	2.16	0.66
30	LA 2639B	0.81	0.74	1.79
32	LA 2681	1.37	1.52	1.42
16	LA 1316	1.25	1.24	1.22
31	LA 2678	1.19	1.37	1.29
33	LA 2695	1.87	1.16	0.74
17	GI 568	1.23	1.28	1.17
13	PI 126440	0.93	1.42	1.16
43	PI 126443	1.08	1.30	0.99
35	LA 0532	1.16	1.94	1.12
14	LA 1401	0.98	1.50	1.41
21	LA 1508	1.07	0.96	1.18
36	LA 0317	1.46	1.62	1.43
6	G 1560	1.29	1.11	1.01
83	LA 1393	1.32	1.03	1.17
12	PI 247087	1.49	1.75	1.07
42	LA 1363	1.47	1.30	1.13
49	LA 1033	1.09	1.04	0.98
63	LA 2167	1.12	1.04	1.09
60	LA 1624	1.27	1.33	1.90
73	PI 126449	1.93	1.26	1.32

46	PI 134417	1.31	1.06	1.41
72	CGN 15879	1.78	1.53	1.52
68	LA 2860	1.29	1.13	1.36
39	LA 3320	1.37	1.19	1.29
40	LA 2662	1.24	2.71	1.04
90	EZ 4	0.91	1.48	1.02
89	EZ 3	0.90	1.86	0.85
92	EZ 6	1.31	1.28	2.10
93	EZ 7	1.07	1.58	1.44
87	EZ 1	1.15	1.71	1.27
41	LA 3120	1.26	1.12	1.19
56	EZ 8	1.05	1.17	1.08
91	EZ 5	1.44	1.92	1.09
80	LA 2711	0.92	1.21	1.29
88	EZ 2	0.95	0.96	1.36
55	Daniela F1	1.01	1.24	0.98
54	Abigail F1	0.94	1.27	1.71
82	LA 1310	1.01	0.99	1.27
85	LA 2874	1.09	1.07	1.03
47	CGN 19145	1.01	0.96	2.02
9	LA 0247	0.98	0.95	1.43
27	LA 2917	1.29	2.04	2.27
28	LA 1319	1.72	2.09	1.99
71	964750062	1.11	1.12	1.40
7	LA 2194	1.14	0.96	1.60
59	LA 1522	1.09	1.49	1.29
65	LA 2560	0.91	1.22	1.04
58	LA 1340	0.90	2.32	0.69
57	LA 1302	1.26	1.26	1.14
64	LA 2548	1.42	1.24	1.15
77	LA 0462	1.24	1.27	1.24
20	PI 128659	0.82	1.58	0.86
11	PI 128653	0.97	1.20	0.76
48	LA 2744	1.26	1.33	0.84
76	PI 126435	1.20	1.61	1.98
74	LA 1910	1.59	1.55	1.12
81	LA 1278	1.08	1.09	1.37
51	PI 126935	1.29	1.47	1.16
78	LA 3218	0.82	1.84	1.33
84	LA 1579	1.07	1.40	1.35
45	PI 407546	1.24	1.05	1.17
24	LA 1259	1.05	1.35	1.19
44	PI 407543	1.23	1.42	0.88
25	LA 1243	0.94	1.52	1.08
50	LA 1223	1.27	0.93	0.80
53	LA 1245	1.14	1.29	1.09
23	LA 1248	1.07	1.16	0.93
10	OT 2209	1.03	1.17	0.94

References

1. Jha D, Shirley N, Tester M, Roy SJ (2010) Variation in salinity tolerance and shoot sodium accumulation in *Arabidopsis* ecotypes linked to differences in the natural expression levels of transporters involved in sodium transport. *Plant Cell and Environment* 33: 793-804.
2. Genc Y, McDonald GK, Tester M (2007) Reassessment of tissue Na⁺ concentration as a criterion for salinity tolerance in bread wheat. *Plant, Cell and Environment* 30: 1486-1498.
3. Munns R, Tester M (2008) Mechanisms of salinity tolerance. *Annual Review of Plant Biology* 59: 651-681.
4. Zhang J-L, Flowers TJ, Wang S-M (2010) Mechanisms of sodium uptake by roots of higher plants. *Plant Soil* 326: 45-60.
5. Munns R, Hare RA, James RA, Rebetzke GJ (2000) Genetic variation for improving the salt tolerance of durum wheat. *Australian Journal of Agricultural Research* 51: 69-74.
6. Tester M, Davenport R (2003) Na⁺ tolerance and Na⁺ transport in higher plants. *Annals of Botany* 91: 503-527.
7. Villalta I, Reina-Sanchez A, Bolarin MC, Cuartero J, Bolver A, et al. (2008) Genetic analysis of Na⁺ and K⁺ concentrations in leaf and stem as physiological components of salt tolerance in tomato. *Theoretical and Applied Genetics* 116: 869-880.
8. Estan MT, Martinez-Rodriguez MM, Perez-Alfocea F, Flowers T. J., Bolarin MC (2005) Grafting raises the salt tolerance of tomato through limiting the concentration of sodium and chloride to the shoot. *Journal of Experimental Botany* 56: 703-712.
9. Flowers TJ (2004) Improving crop salt tolerance. *Journal Experimental Botany* 55.
10. Foolad MR (2004) Recent advances of salt tolerance in tomato. *Plant cell Tissue and Organ Culture* 76: 101-119.
11. Cuartero J, Fernandez-Munoz R (1999) Tomato and salinity. *Scientia Horticulturae* 78: 83-125.
12. Cuartero J, Bolarin MC, Asins MJ, Moreno V (2006) Increasing salt tolerance in the tomato. *Journal of Experimental Botany* 57: 1045-1058.
13. Perez-Alfocea F, Estan MT, Santa CA, Bolarin MC (1993) Effects of salinity on nitrate, total nitrogen, soluble protein and free amino acid levels in tomato plants. *Journal of Horticultural Science* 68: 1021-1027.
14. Martinez-Rodriguez MM, Estan MT, Moyano E, Garcia-Abellan JO, Flores FB, et al. (2008) The effectiveness of grafting to improve salt tolerance in tomato when an "excluder" genotype is used as scion. *Environmental and Experimental Botany* 63: 392-401.
15. Albacete A, Martinez-Andujar C, Ghanem M, E., Acosta M, Sanchez-Bravo J, et al. (2009) Rootstock-mediated changes in xylem ionic and hormonal status are correlated with delayed leaf senescence, and increased leaf area and crop productivity in salinized tomato. *Plant Cell and Environment* 32: 928-938.
16. Tal M (1971) Salt tolerance in the wild relatives of the cultivated tomato: responses of *Lycopersicon esculentum*, *L. peruvianum* and *L. esculentum minor* to sodium chloride solution. *Australian Journal of Agricultural Research* 22: 631-638.
17. Rush DW, Epstein E (1981) Breeding and selection for salt tolerance by the incorporation of wild germplasm into a domestic tomato. *Journal American Society Horticultural Science* 106: 699-704.
18. Bolarin MC, Gernandez FG, Cruz V, Cuartero J (1991) Salinity tolerance in four wild tomato species using vegetative yield-salinity response curves. *Journal American Society Horticultural Science* 116: 286-290.
19. Shannon MC (1997) Adaptation of plants to salinity. *Advances in Agronomy* 60: 75-120.
20. Perez-Alfocea F, Balibrea ME, Santa-Cruz A, Estan MT (1996) Agronomical and physiological characterization of salinity tolerance in a commercial tomato hybrid. *Plant and Soil* 180: 251-257.
21. Genc Y, Oldach K, Verbyla A, Lott G, Hassan M, et al. (2010) Sodium exclusion QTL associated with improved seedling growth in bread wheat under salinity stress. *TAG Theoretical and Applied Genetics*.

22. Fairbairn DJ, Liu WH, Schachtman DP, Gomez-Gallego S, Day SR, et al. (2000) Characterisation of two distinct HKT1-like potassium transporters from *Eucalyptus camaldulensis*. *Plant Molecular Biology* 43: 515-525.
23. Sun W, Xu X, Zhu H, Liu A, Liu L, et al. (2010) Comparative transcriptomic profiling of a salt-tolerant wild tomato species and a salt-sensitive tomato cultivar. *Plant and Cell Physiology* 51: 997-1006.
24. Saeed A, Shahid MQ, Anjum SA, Khan AA, Shakeel A, et al. (2011) Genetic analysis of NaCl tolerance in tomato. *Genetics and Molecular Research* 10: 1756-1776.
25. Shaaban MM, El-Fouly MM, Zanaty EL, El-Nour AAA, Abdel-Maguid A-WA (2004) Halophytes and foliar fertilization as a useful technique for growing processing tomatoes in the saline affected soils. *Pakistan Journal of Biological Sciences* 7: 503-507.
26. Gain P, Mannan MA, Pal PS, Hossain MM (2004) Effect of salinity on some yield attributes of rice. *Pakistan Journal of Biological Sciences* 7: 760-762.
27. Agong SG, Yoshida Y, Yazawa S, Masuda M (2004) Tomato response to salt stress. *Advances in vegetable breeding. XXVI International horticultural congress. International Society for Horticultural Science. Acta Horticulturae* 637: 93-97.
28. Miller JC, Tanksley SD (1990) RFLP analysis of phylogenetic relationships and genetic variation in the genus *Lycopersicon*. *Theoretical and Applied Genetics* 80: 437-448.
29. Schauer N, Zamir D, Fernie AR (2005) Metabolic profiling of leaves and fruit of wild species tomato: a survey of the *Solanum lycopersicum* complex. *Journal of Experimental Botany* 56: 297-307.
30. Pan Q, Liu YS, Budai-Hadrian O, Sela M, Carmel-Goren L, et al. (2000) Comparative genetics of nucleotide binding site-leucine rich repeat resistance gene homologues in the genomes of two dicotyledons: tomato and *Arabidopsis*. *Genetics* 155: 309-322.
31. Fridman E, Pleban T, Zamir D (2000) A recombination hotspot delimits a wild-species quantitative trait locus for tomato sugar content to 484 bp within an invertase gene. *Proceedings of the National Academy of Sciences USA* 97: 4718-4723.
32. Ronen G, Carmel-Goren L, Zamir D, Hirschberg J (2000) An alternative pathway to beta carothene formation in plant chromoplasts discovered by map-based cloning of beta and old-gold color mutations in tomato. *Proceedings of the National Academy of Sciences USA* 97: 11102-11107.
33. Baek D, Jiang JF, Chung JS, Wang BS, Chen JP, et al. (2011) Regulated *AtHKT1* gene expression by a distal enhancer element and DNA methylation in the promoter plays an important role in salt tolerance. *Plant and Cell Physiology* 52: 149-161.
34. Davenport RJ, Munoz-Mayor A, Jha D, Essah PA, Rus A, et al. (2007) The Na⁺ transporter AtHKT1;1 controls retrieval of Na⁺ from the xylem in *Arabidopsis*. *Plant Cell and Environment* 30: 497-507.
35. Moller IS, Gilliam M, Jha D, Mayo GM, Roy SJ, et al. (2009) Shoot Na⁺ exclusion and increased salinity tolerance engineered by cell type-specific alteration of Na⁺ transport in *Arabidopsis*. *Plant Cell* 21: 2163-2178.
36. Rus A, Baxter I, Muthukumar B, Gustin J, Lahner B, et al. (2006) Natural variants of AtHKT1 enhance Na⁺ accumulation in two wild populations of *Arabidopsis*. *PloS Genetics* 2: 1964-1973.
37. Rus A, Yokoi S, Sharkhuu A, Reddy M, Lee BH, et al. (2001) AtHKT1 is a salt tolerance determinant that controls Na⁺ entry into plant roots. *Proceedings of the National Academy of Sciences of the United States of America* 98: 14150-14155.
38. Sunarpi, Horie T, Motoda J, Kubo M, Yang H, et al. (2005) Enhanced salt tolerance mediated by AtHKT1 transporter-induced Na⁺ unloading from xylem vessels to xylem parenchyma cells. *Plant Journal* 44: 928-938.
39. Uozumi N, Kim EJ, Rubio F, Yamaguchi T, Muto S, et al. (2000) The *Arabidopsis HKT1* gene homolog mediates inward Na⁺ currents in *Xenopus laevis* oocytes and Na⁺ uptake in *Saccharomyces cerevisiae*. *Plant Physiology* 122: 1249-1259.
40. Baxter I, Brazelton JN, Yu DN, Huang YS, Lahner B, et al. (2010) A Coastal cline in sodium accumulation in *Arabidopsis thaliana* is driven by natural variation of the sodium transporter AtHKT1;1. *PloS Genetics* 6.

41. Galpaz N, Reymond M (2010) Natural variation in *Arabidopsis thaliana* revealed a genetic network controlling germination under salt stress. PLoS One 5: e15198.
42. Katori T, Ikeda A, Iuchi S, Kobayashi M, Shinozaki K, et al. (2010) Dissecting the genetic control of natural variation in salt tolerance of *Arabidopsis thaliana* accessions. Journal of Experimental Botany 61: 1125-1138.
43. Vallejo AJ, Yanovsky JM, Botto FJ (2010) Germination variation in *Arabidopsis thaliana* accessions under moderate osmotic and salt stresses. Annals of Botany 106: 833-844.
44. Khan MIR, Iqbal N, Masood A, Khan NA (2012) Variation in salt tolerance of wheat cultivars: role of glycinebetaine and ethylene. Pedosphere 22: 746-754.
45. Oztekin GB, Tuzel Y (2011) Comparative salinity responses among tomato genotypes and rootstocks. Pakistan Journal of Botany 43: 2665-2672.
46. Munns R, James RA (2003) Screening methods for salinity tolerance: a case study with tetraploid wheat. Plant and Soil 253: 201-218.
47. Colmer TD, Flowers TJ, Munns R (2006) Use of wild relatives to improve salt tolerance in wheat. Journal of Experimental Botany 57: 1059-1078.
48. Colmer TD, Munns R, Flowers TJ (2005) Improving salt tolerance of wheat and barley: future prospects. Australian Journal of Experimental Agriculture 45: 1425-1443.
49. Munns R, James RA, Lauchli A (2006) Approaches to increasing the salt tolerance of wheat and other cereals. Journal of Experimental Botany 57: 1025-1043.
50. Alfocea FP, Estan MT, Caro M, Bolarin MC (1993) Responses of tomato cultivars to salinity. Plant and Soil 150: 203-211.
51. Ren ZH, Gao JP, Li LG, Cai XL, Huang W, et al. (2005) A rice quantitative trait locus for salt tolerance encodes a sodium transporter. Nature Genetics 37: 1141-1146.
52. Munns R., James RA, Xu B, Athman A, Conn JS, et al. (2012) Wheat grain yield on saline soils is improved by an ancestral Na⁺ transporter gene. Nature Biotechnology 30: 360-364.
53. Cotsaftis O, Plett D, Shirley N, Tester M, Hrmova M (2012) A two-staged model of Na⁺ exclusion in rice explained by 3D modeling of HKT transporters and alternative splicing. PLoS One 7: e39865.
54. Plett D, Safwat G, Gilliam M, Moller IS, Roy S, et al. (2010) Improved Salinity Tolerance of Rice Through Cell Type-Specific Expression of *AtHKT1;1*. PloS One 5.
55. Guerrier G (1996) Fluxes of Na⁺, K⁺ and Cl⁻, and osmotic adjustment in *Lycopersicon pimpinellifolium* and *L. esculentum* during short- and long-term exposures to NaCl. Physiology Plantarum 97: 583-591.
56. Galvez FJ, Baghour M, Hao G, Cagnac O, Rodriguez-Rosales MP, et al. (2012) Expression of *LeNHX* isoforms in response to salt stress in salt sensitive and salt tolerant tomato species. Plant Physiology and Biochemistry 51: 109-115.

Chapter 3

Analysis of physiological and genetic parameters in the salinity tolerance of 24 tomato accessions

Pedro Almeida^{1*}, Richard Feron², Gert-Jan de Boer² and Albertus H. de Boer¹

¹Vrije Universiteit Amsterdam, Faculty Earth and Life Sciences, Department of Structural Biology, NL-1081 HV Amsterdam, the Netherlands

²Enza Zaden, Research and Development, Haling 1/E, 1602 DB Enkhuizen

*Corresponding author: p.m.fidalgodealmeida@vu.nl

Abstract

Tomato is one of the most important horticultural crops. However, elite varieties can withstand salinity stress poorly. A feasible way of improving yield in conditions of salinity stress is to breed for improved tolerance. In this study we analysed physiological and genetic parameters of 24 tomato accessions previously selected based on their differences in Na⁺ accumulation. Although a wide range of Na⁺ concentrations within the leaves, stems and roots was observed, the maintenance of growth in the presence of 100 mM NaCl was not correlated with the exclusion or accumulation of Na⁺. Nor was the growth correlated with the accumulation of sugars or proline or with the expression of any gene involved in the homeostasis of Na⁺ in the plant. However, several significant correlations between the expression of genes and Na⁺ accumulation were observed. For instance, both Na⁺ concentrations in the leaves and stems were positively correlated with *SIHKT1;2* expression in the roots and Na⁺ concentration measured in the roots was positively correlated with *SIHKT1;1* expression also in the roots. Higher and lower Na⁺ accumulations in the roots and leaves were significantly correlated with higher *NHX3* and *NHX1* expression in the roots, respectively. The results presented in this Chapter suggest that Na⁺ exclusion or inclusion and tissue tolerance evolved independently in tomato plants. In consequence, salinity tolerance can be achieved due to different combinations of Na⁺ concentrations and tissue tolerance in tomato plants.

Introduction

One of the major abiotic stresses that agriculture faces nowadays is salinity [1,2]. An excessive amount of salt in the soil negatively affects plant germination, growth, development, and productivity [3]. A very important mechanism of salinity tolerance is the ability to minimize the amount of Na^+ entering the plant via the roots [1,4,5]. The control of Na^+ transport at the cellular level by secreting and sequestering it in tissues, cells or organelles, where less harm is caused, is also critical to the achievement of salinity tolerance [6,7]. In fact, a great contributor to salinity stress is the accumulation of high concentrations of Na^+ in the leaf cell cytoplasm [8]. In some species, however, Cl^- is the main stressful ion [9]. This does not mean that Cl^- has a higher metabolic toxicity than Na^+ , but that these species are better at excluding Na^+ than Cl^- [1]. Interestingly, several studies show that, besides Na^+ exclusion, also tissue tolerance to high Na^+ concentrations plays an important role in salinity tolerance [8,10,11]. In this way, the understanding of the mechanisms involved in the uptake and movement of Na^+ throughout the plant and the genes involved is crucial [8] in the improvement of the salinity tolerance of current crop varieties.

This study analyzed 24 tomato accessions, selected from the previous Chapter, aiming to find a trait or gene(s) that breeders can use to select for in new breeding programs. In this analysis we hope to couple gene expression to variation in levels of ions and organic molecules. In this way, we do not only have a parameter like Na^+ or proline accumulation, but also a link with genes that are responsible for variations in the levels of these parameters.

Studies done with *Arabidopsis* [12-15], rice [16-18], *Eucalyptus* [19], barley [20], and *Thellungiella* [21] showed that *HKT* genes are involved in the control of the Na^+ movement throughout the plant. The *HKT* gene family encodes proteins that are responsible for the influx of Na^+ into the cells [12,15]. This family is divided into two subfamilies depending on the nucleic acid sequences and protein structure of their members [22]. Members of subfamily 1 have an important role in salinity tolerance [12,16]. *athkt1;1* mutants have no *HKT1;1* expression and the *Arabidopsis* ecotypes Tsu1 and Ts1 have 10 times lower *HKT1;1* expression in the roots in comparison to Col-0 [23]. This absence/low root expression correlates with hyper-accumulation of Na^+ in the shoots and reduced accumulation in the roots [23]. Cell-type specific overexpression of *AtHKT1;1* in the root stele of *Arabidopsis* plants [15], and in the root cortex of rice plants [24] results in a significant decrease of Na^+ accumulation in the shoots and in the increase of tolerance to salinity in these plants. Studies performed with *atsos1* mutant plants suggest that the efflux of Na^+ from the cells is mainly

done by the plasma membrane Na^+/H^+ antiporter AtSOS1 [25]. SOS1 is part of the SOS signal transduction pathway [26,27]. This pathway is crucial for ion homeostasis and salt tolerance in plants [26,27]. In this pathway, changes in cytosolic calcium due to salt stress, are sensed by a calcium-binding protein, SOS3 [28]. SOS3 interacts with and activates the serine/threonine protein kinase SOS2 [29] after which the SOS3/SOS2 kinase complex phosphorylates and activates SOS1 [30]. Shi et al. show that over-expression of *AtSOS1* in *Arabidopsis* improves its salt tolerance through the limitation of Na^+ accumulation in plant cells [31]. Another ion transport protein with a very important role in salinity tolerance is the vacuolar Na^+/H^+ antiporter AtNHX1. This transporter is responsible for the detoxification of the cytoplasm by pumping Na^+ into the vacuole [32]. Several studies show that over-expression of *AtNHX* or its homologs from other species improve the salt tolerance of plants [33-37]. Many transport processes occurring in plants are directly or indirectly energized by the proton gradient across membranes produced by H^+ -pumping ATPases [38]. At the plasma membrane, the *LHA* gene family encodes P-type ATPases, that create a H^+ gradient used to energise, among other processes, the extrusion of Na^+ [35], via SOS1. High *LHA* expression levels are always observed in cells where intense active transport takes place [39,40]. *AtAVPI* encodes a vacuolar H^+ -translocating pyrophosphatase (H^+ -PPase) that transports H^+ across the tonoplast [6]. This proton motive force across the tonoplast provides the energy for the transport of Na^+ into the vacuoles through Na^+/H^+ antiporters like AtNHX1 [41]. When *AtAVPI* is over-expressed in *Arabidopsis* an increase in salinity tolerance is observed through a better sequestration of Na^+ in the vacuole [41].

In plants suffering from salinity stress, the production of compatible solutes has also shown to be an effective mechanism protecting plants. Both amino acids and sugars are non-toxic compounds that accumulate, preferentially in the cytoplasm, helping not only to maintain the turgor and osmotic balance but also to protect the cell structure from stress [42]. Salinity stress induces the accumulation of proline in several plant species including tomato [43]. Proline functions both as an osmolyte and osmoprotectant [42]. Proline can be synthesised via two different pathways from either glutamate or ornithine [44]. However, the glutamate pathway seems to be the predominant pathway in conditions of osmotic stress [45]. The first two steps of proline biosynthesis from glutamate are catalysed by the enzyme Δ^1 -pyrroline-5-carboxylate synthetase P5CS [46]. The *P5CS* gene was isolated in several species including rice [47], *Arabidopsis* [48] and tomato [43] and its induction and the accumulation of proline were shown to correlate in rice and *Arabidopsis* [47,48]. Salinity stress also causes the accumulation of sucrose [49]. Sucrose is not toxic in the cytoplasm and allows turgor

maintenance as well as it protects the structure of molecules against the deleterious effects of water scarcity [49-51].

Tomato is one of the most important horticultural crops [52]. However, elite varieties can withstand salinity stress poorly. This is a result of the usual breeding strategies where the breeding target trait is yield increment in optimal conditions [52]. This is the reason why only 10% of all genetic variability amongst all tomato species is present in elite tomato varieties [53]. The enormous genetic variation present in the tomato wild species is very important in the development of new salinity tolerant cultivars. The introduction of genes from wild species of tomato can be achieved by simply crossing *S. lycopersicum* with other *Solanum* species of the *Solanum lycopersicum* complex. *Solanum pimpinellifolium*, *Solanum neorickii*, *Solanum chmielewskii* and *Solanum pennellii* constitute this complex. Tolerance means adaptation and wild *Solanum* species are adapted to marginal environments. In this way, modern breeding programs should take advantage of this adaptation shown by wild *Solanum* species [52].

In this study, 24 tomato accessions were salt treated for two weeks after which the concentration of Na^+ , K^+ and Cl^- was measured in leaf, stem and root tissues. Proline and sucrose were measured only in leaf tissue. RNA was extracted from root and leaf tissue and used to produce cDNA. cDNA was used in gene expression analysis of genes involved in Na^+ homeostasis and proline synthesis. Our results showed that, based on the Plant Tolerance Index scores, LA 1245 and OT 2209 were the most tolerant and sensitive accessions, respectively. Na^+ , K^+ , Cl^- , proline or sucrose concentrations did not correlate with salt sensitivity or tolerance. Nevertheless, several significant correlations between the expression of genes and Na^+ accumulation were observed. For instance, both Na^+ concentrations in the leaves and stems were positively correlated with *SIHKT1;2* expression in the roots and Na^+ concentration measured in the roots correlated positively with *SIHKT1;1* expression also in the roots. Higher and lower Na^+ accumulations in the roots and leaves were significantly correlated with higher *NHX3* and *NHX1* expression in the roots, respectively. The results presented in this Chapter suggest that Na^+ exclusion or inclusion and tissue tolerance evolved independently in tomato plants. In consequence, salinity tolerance can be achieved with different combinations of Na^+ concentrations and tissue tolerance in tomato plants.

Material and methods

Plant material

Growth conditions and salinity treatments were performed as described in Chapter 2. Tomato accessions used in this experiment were: *Solanum chilense* LA 1938 and LA 1959; *Solanum chmielewskii* LA 1325 and LA 2695; *Solanum corneliomuelleri* GI 568 and PI 126443; *Solanum galapagense* LA 0532 and LA 0317; *Solanum habrochaites* G1560 and LA 2167; *Solanum habrochaites glabratum* LA 2860 and PI 126449; *Solanum lycopersicum* Abigail F1, LA 3320, LA 2711 and Arbasson F1; *Solanum neorickii* LA 2194; *Solanum pennellii* LA 1340 and LA 1522; *Solanum pennellii puberulum* LA 1302; *Solanum peruvianum* LA 3218 and LA 2548; *Solanum pimpinellifolium* OT 2209 and LA 1245.

Na⁺, K⁺ and Cl⁻ measurements

Na⁺ and K⁺ measurements were performed as described in Chapter 2. Cl⁻ ions were measured directly on the filtered samples also used for Na⁺ and K⁺ measurements on a chloride meter (MKII Chloride Analyzer 926, Sheerwood, UK). Calibration was done using 10 ml of Combined Acid Buffer (Sheerwood, UK) where 500 µl of Chloride Meter Standard (Sheerwood, UK) was diluted.

Soluble sugars

10 mg of dried leaf material was weighed and inserted in 2 ml tubes. 1 ml of 80% ethanol was added to each sample and the tubes were incubated for 90 min at 70 °C in a water bath. Samples were regularly vortexed to assure an efficient ethanol extraction of sugars. After incubation, samples were centrifuged at full speed (14,000 RPM) for 10 min at room temperature. 800 µl of the supernatant was transferred to a new 2 ml tube and 800 µl of Milli-Q water was added. 10 µl of this solution was used with the Sucrose/D-Glucose/D-Fructose–UV test Kit (R-Biopharm, Germany) to quantify sugars according to the manufacturer's protocol. For the calibration, 250 mg of glucose, sucrose and fructose were dissolved in a 250 ml volumetric flask containing 40% ethanol. A dilution series was made (0, 2, 4, 8, 16 times dilution) and used for the standard curve. Two technical replicates, per each analysed sample, were used for the calculations.

Proline

For the quantification of proline, between 20 and 30 mg dry leaf material from control and salt treated plants were used. Extraction and quantification were made according to Bates et al. [54].

RNA extraction, complementary DNA synthesis and quantitative PCR

For the extraction of RNA, 30 mg of frozen material (root and leaf) was used. A NucleoSpin 96 RNA Kit (Macherey-Nagel) was used and the RNA was extracted according to the manufacturer's protocol. After extraction, 5 µl of RNA were incubated at 37 °C for 10 min and tested in an agarose gel to check for the quality. The concentration was measured using a NanoDrop (ThermoScientific). First strand cDNA was synthesized using 1 µg of total RNA, 200 Units of SuperScript II Reverse Transcriptase (Invitrogen Life Technologies), 1 mM dNTPs, 100 mM DTT, 5x First Strand Buffer and 10 µM oligo dT primer, at 37 °C for 50 minutes. cDNA was used as a template for quantitative real-time PCR (qRT-PCR) according to Livak and Schmittgen [55]. Public available primers were used in this experiment with the exception of *SIP5CS* primer pair (Table S1). *SIP5CS* primers were designed and blasted against the whole tomato genome using SOL Genomics Network (www.solgenomics.net). One single hit was produced for both primers showing that this primer pair was specific for this gene. Quantitative PCR was performed using a Fluidigm Biomark™ system (, USA) according to the manufacturer's manual (<http://www.fluidigm.com/product-documents.html>).

Statistical analysis

To assess the effect of salt treatment on Na⁺, K⁺, Na⁺/K⁺ and Cl⁻ levels per accession, we used the Student's *t* test. If the values were not normally distributed or if the assumption of homogeneity of variance was violated, we transformed the data. We performed Pearson's correlations between the different accessions or in the case of rank transformed data, we performed Spearman's rank correlations. All analyses were conducted using SPSS 17.0.

Results

Fig. 1 shows representative photographs of all accessions used at the moment of harvesting. We started this experiment with 24 different accessions, but because several plants from accession LA 3218 did die (both control and treated plants) during the growth period, not

enough plant material was available to perform all analysis with this accession. Therefore, all the results presented were obtained from experiments using 23 accessions.

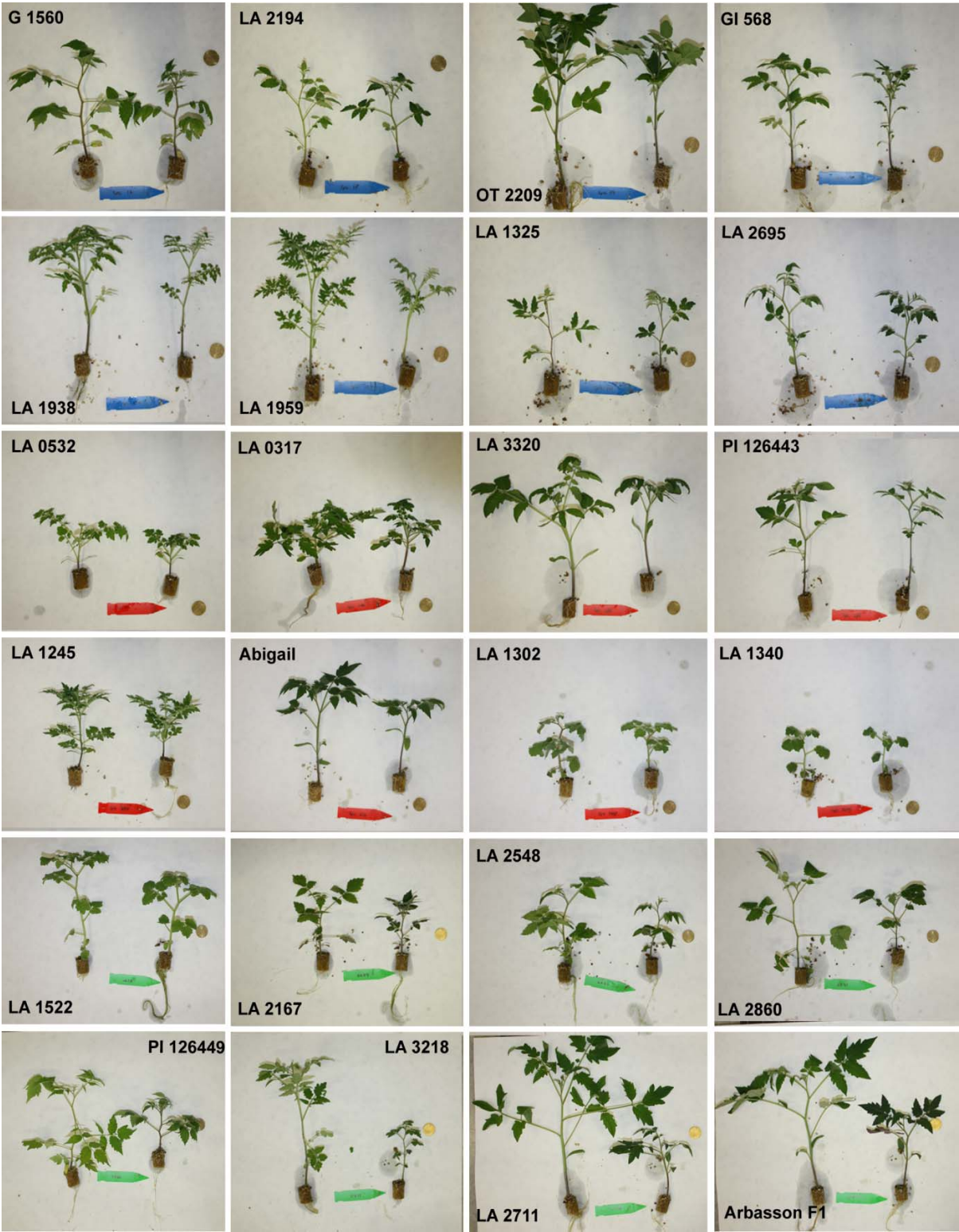

Figure 1: Representative photographs of the 24 accessions used in this study at the day of harvest. The plant on the left of each photograph is a representative of control plants, whereas the plant on the right is a representative for all salt treated plants of that accession.

Tomato salinity tolerance does not correlate to Na⁺ concentration

Several salt stressed plants showed a significant reduction in the amount of shoot fresh weight after the two week period of the salt treatment compared to that of control plants (Table 1). However, *S. corneliomuelleri* GI 568, *S. chmielewskii* LA 1325, *S. corneliomuelleri* PI 126443, *S. pimpinelifolium* LA 1245, *S. lycopersicum* Abigail F1, and *S. pennellii* LA 1340 and LA 1522 showed no significant reduction in shoot fresh weight produced when treated with NaCl. With the exception of *S. lycopersicum* Abigail F1, accessions without a significant reductions in shoot FW in the presence of salt, when treated with NaCl, were the same accessions that performed well according to the Plant Tolerance Index (PTI) (see [8] (Table 2). In this study, we defined PTI as the ratio between the FW of salt treated shoots / FW of control shoots. We did not use total plant FW because it was not possible to harvest the total amount of roots produced by each individual plant. Based on the PTI, the most salt sensitive accession was *S. chilense* LA 1938 (PTI=0.37) and the most salt tolerant accession was *S. pimpinelifolium* LA 1245 (PTI = 0.98).

Table 1: Tolerance to salinity of 23 tomato accessions grown in rockwool plugs soaked with Hoagland's solution and treated with either 0 or 100 mM NaCl for 2 weeks. Values indicate the means±SE of three biological replicates. The asterisks indicate significant differences according to Student's t-Test (* p <0.05).

Accession	Species	Treatment (mM NaCl)	Shoot Fresh Weight (g)	PTI (FWshoots salt/ FWshoots control)
Arbasson F1	<i>S. lycopersicum</i>	0	5.24±1.38 *	0.46±0.06
		100	2.36±0.54	
LA 1938	<i>S. chilense</i>	0	2.47±0.87 *	0.37±0.05
		100	0.89±0.25	
LA 1959	<i>S. chilense</i>	0	2.00±0.13 *	0.48±0.08
		100	0.97±0.29	
LA 1325	<i>S. chmielewskii</i>	0	0.59±0.01	0.71±0.14
		100	0.42±0.14	
LA 2695	<i>S. chmielewskii</i>	0	1.10±0.10 *	0.53±0.06
		100	0.59±0.16	
GI 568	<i>S. corneliomuelleri</i>	0	2.31±0.60 *	0.66±0.12
		100	1.44±0.21	
PI 126443	<i>S. corneliomuelleri</i>	0	1.78±0.21	0.71±0.13
		100	1.23±0.26	
LA 0532	<i>S. galapagense</i>	0	1.30±0.16 *	0.50±0.06
		100	0.65±0.09	
LA 0317	<i>S. galapagense</i>	0	2.77±0.14 *	0.50±0.06
		100	1.37±0.23	
G 1560	<i>S. habrochaites</i>	0	2.81±0.28 *	0.60±0.09
		100	1.67±0.25	
LA 2167	<i>S. habrochaites</i>	0	1.34±0.16 *	0.67±0.08
		100	0.89±0.13	
LA 2860	<i>S. habrochaites glabratum</i>	0	2.85±0.27 *	0.56±0.05
		100	1.60±0.31	
PI 126449	<i>S. habrochaites glabratum</i>	0	2.20±0.21 *	0.65±0.08
		100	1.41±0.21	
LA 3320	<i>S. lycopersicum</i>	0	6.65±1.10 *	0.39±0.08
		100	2.52±0.73	
Abigail	<i>S. lycopersicum</i>	0	4.17±1.84	0.57±0.13
		100	1.71±0.03	
LA 2711	<i>S. lycopersicum</i>	0	5.33±0.33 *	0.43±0.07
		100	2.27±0.55	
LA 2194	<i>S. neorickii</i>	0	1.60±0.42 *	0.54±0.11
		100	0.82±0.05	
LA 1340	<i>S. pennellii</i>	0	0.87±0.08	0.77±0.12
		100	0.65±0.11	
LA 1522	<i>S. pennellii</i>	0	3.32±0.49	0.76±0.12
		100	2.46±0.30	
LA 1302	<i>S. pennellii puberulum</i>	0	1.78±0.29 *	0.57±0.16
		100	0.96±0.29	
LA 2548	<i>S. peruvianum</i>	0	2.09±0.54 *	0.44±0.04
		100	0.90±0.11	
OT 2209	<i>S. pimpinellifolium</i>	0	4.31±0.24 *	0.44±0.05
		100	1.92±0.39	
LA 1245	<i>S. pimpinellifolium</i>	0	1.26±0.22	0.98±0.11
		100	1.25±0.44	

Variation could also be observed in the concentrations of Na^+ , K^+ and Cl^- and Na^+/K^+ ratio measured in the three tissues analysed of all accessions (Table S1A to S1C). All accessions showed significant increases in Na^+ and Cl^- concentrations and Na^+/K^+ ratios, in all tissues, when treated with 100 mM NaCl. Interestingly, the accumulation of Na^+ in the different tissues showed no correlation with the PTI values (Fig. 2). In salt treated plants, not all accessions showed a significant reduction in K^+ concentrations. Chloride measurements in all tissues analysed showed significant increases in Cl^- concentrations when plants were treated with 100 mM NaCl.

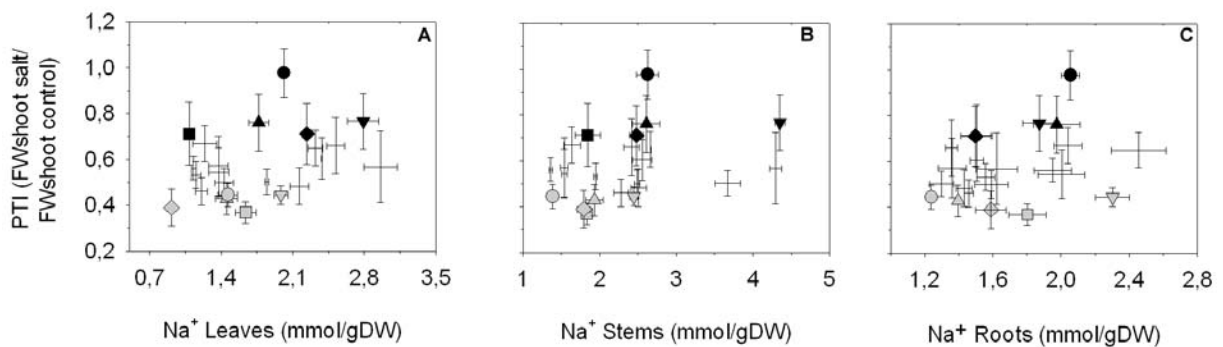

Figure 2: Relationship between Plant Tolerance Index (PTI) and Na^+ accumulation in the (A) leaves, (B) stems and (C) roots of tomato plants treated with 100 mM NaCl for two weeks before being harvested. Black symbols represent the five accessions with higher PTI values: LA 1325 (■), PI 126443 (◆), LA 1522 (▲), LA 1340 (▼) and LA 1245 (●). Grey symbols represent the five accessions with lower PTI values: LA 1938 (■), LA 3320 (◆), LA 2711 (▲), LA 2548 (▼) and OT 2209 (●). Values indicate the means \pm SE of three biological replicas. No statistically significant correlation was found for any of the three correlations. PTI vs $[\text{Na}^+]$ leaves and PTI vs $[\text{Na}^+]$ roots were tested using the Pearson correlation coefficient whereas PTI vs $[\text{Na}^+]$ stems was tested using the Spearman correlation coefficient.

“Includer” vs “excluder” strategy

Plots of Na^+ and K^+ measured in leaves, stems and roots (Fig. S1), show the pattern of accumulation in the accessions under study. When Na^+ accumulation in control and treated plants was plotted for leaves (Fig. S2A), stems (Fig. S2D) and roots (Fig. S2G), an interesting result was observed. Shoots (leaves and stems) but not roots showed a significant correlation between Na^+ accumulation in control and treated plants. “Includer” and “excluder” plants could be distinguished as those that accumulate more Na^+ when submitted to NaCl treatment are also those that accumulated more Na^+ under control conditions. K^+ accumulation also

showed a significant correlation between control and treated plants, in this case for leaves (Fig. S1B), stems (Fig. S1E) and roots (Fig. S1H). Accessions accumulating more K^+ in the control situation were also able to maintain higher K^+ concentrations when treated with 100 mM NaCl. Na^+/K^+ ratio only showed significant correlations for leaves (Fig. S1C) and stems (Fig. S1F). Similar to Na^+ and K^+ accumulation, no clear correlation between Na^+/K^+ ratio and salinity tolerance of these tomato accessions was observed.

Distribution of Na^+ , K^+ and Cl^- within the plant

To better understand how Na^+ and K^+ and Na^+/K^+ ratio are distributed within the plant, we plotted these values measured in the leaves against those measured in the stems (Fig. S2A to S2C) and in the roots (Fig. S2D to S2F) and those measured in the stems against those measured in the roots (Fig. S2G to S2I). Plants that showed higher Na^+ accumulation in the leaves were also those that showed higher Na^+ accumulation in the stems (Fig. S2A). Interestingly, this accumulation in the shoots happened independently from the Na^+ accumulation in the roots, as no correlation existed between Na^+ accumulation in the leaves (Fig S2D), or in the stems (Fig. S2G) vs Na^+ accumulation in the roots. For K^+ concentration, no correlation existed between accumulations in any of the plant tissues analysed (Figs. S2B, S2E, S2H). Regarding Na^+/K^+ ratios, only Na^+/K^+ ratio in the leaves and in the stems showed a statistically significant correlation (Fig. S2C).

The correlation of Na^+ and Cl^- concentrations measured in the leaves, stems and roots (Fig. S3) revealed statistically significant correlations in the leaves and in the stems but not in the roots. This result is in line with the results shown in Fig S2A, as plants accumulating higher amounts of Na^+ do also accumulate higher amounts of Cl^- .

Proline and Sucrose accumulation in the leaves

Among all compatible compounds produced by plants when in stress situations, proline is perhaps the most studied one. Under hyperosmotic conditions, proline plays a major role in several plant species. In these conditions, sucrose accumulated as well [49], and is also involved in turgor maintenance as well as protection of the structures of molecules against the scarcity of water [49-51]. For these reasons, in this study, proline and sucrose concentrations in the leaves of both control and salt treated plants were measured. All tomato plants treated with 100 mM NaCl for three weeks showed a significant increase in the concentration of both proline and sucrose measured in the leaves (Table 2, See Figs. S4 and S5 for graphs). Correlations between either Na^+ (Fig. S6A), K^+ (Fig. S6B), or Cl^- (Fig. S6C), and proline

concentration measured in the leaves of salt treated plants were not statistically significant. The relationship between sucrose and, either Na⁺, K⁺ or Cl⁻, all measured in the leaves, or PTI, was also analysed and did not show a significant correlation either (data not shown).

Table 2: Content of proline and sucrose (mM) measured in leaf tissue of control and salt treated plants. Values indicate the means±SE of three biological replicas. Smaller concentration values have a green background, whereas higher concentration values have a red background. All increases in both proline and sucrose in salt treated plants are statistically significant according to Student's t-test ($p < 0.05$).

Accession	Species	Proline		Sucrose	
		0 mM	100 mM	0 mM	100 mM
Arbasson F1	<i>S. lycopersicum</i>	6.24±0.89	47.79±4.66	20.87±2.48	37.54±2.32
LA 1938	<i>S. chilense</i>	14.94±0.96	43.13±2.08	24.73±1.24	60.49±2.48
LA 1959	<i>S. chilense</i>	12.23±0.32	52.20±0.89	26.92±1.28	62.35±1.96
LA 1325	<i>S. chmielewskii</i>	4.99±0.66	29.81±1.74	15.28±1.61	43.93±1.87
LA 2695	<i>S. chmielewskii</i>	15.97±1.17	52.65±2.53	16.44±1.58	47.19±1.38
GI 568	<i>S. corneliomuelleri</i>	24.22±1	34.11±1.3	17.20±1.42	39.21±2.71
PI 126443	<i>S. corneliomuelleri</i>	30.51±0.28	55.64±2.25	26.44±1.34	56.92±7.09
LA 0532	<i>S. galapagense</i>	6.55±2.15	38.88±1.67	14.31±1.07	54.22±3.83
LA 0317	<i>S. galapagense</i>	7.58±0.17	65.28±0.9	14.77±3.13	33.06±5.92
G 1560	<i>S. habrochaites</i>	19.58±1.87	50.2±8.15	14.17±1.88	54.16±1.98
LA 2167	<i>S. habrochaites</i>	6.11±0.02	37.22±3.78	16.04±2.82	48.57±4.59
LA 2860	<i>S. habrochaites glabratum</i>	9.52±1.63	47.76±0.93	13.91±2.19	54.26±0.85
PI 126449	<i>S. habrochaites glabratum</i>	8.15±0.43	57.58±2.52	16.46±1.85	58.54±1.18
LA 3320	<i>S. lycopersicum</i>	10.65±0.1	91.06±5.97	24.19±0.59	35.32±2.09
Abigail F1	<i>S. lycopersicum</i>	9.76±1.02	62.18±2.68	27.58±0.7	40.38±0.12
LA 2711	<i>S. lycopersicum</i>	9.39±0.85	43.56±1.6	23.27±4.71	51.11±0.76
LA 2194	<i>S. neorickii</i>	4.22±0.59	31.55±4.43	11.47±0.27	24.12±0.32
LA 1340	<i>S. pennellii</i>	1.76±0.35	25.77±2.85	8.75±1.43	36.40±1
LA 1522	<i>S. pennellii</i>	1.66±0.02	32.15±0.94	6.89±0.59	47.26±0.13
LA 1302	<i>S. pennellii puberulum</i>	8.32±0.61	36.86±0.8	13.07±1.28	27.71±1.63
LA2548	<i>S. peruvianum</i>	4.91±1.24	35.34±0.37	13.46±0.64	53.87±2.42
OT 2209	<i>S. pimpinellifolium</i>	12.76±1.9	54.31±2.22	17.88±5.60	55.58±1.7
LA 1245	<i>S. pimpinellifolium</i>	4.95±0.63	36.80±2.79	35.70±0.98	55.39±1.5

Gene expression analysis of transporters involved in Na⁺ homeostasis

The variation observed in the growth and in the ion accumulation between the accessions under study was also observed at the gene expression level. In this study we analysed several genes involved in the Na⁺ homeostasis throughout the plant and we tried to correlate their

expression patterns with Na⁺ and proline accumulation. Large differences were observed, both in accessions classified as tolerant and in accessions classified as sensitive to salinity. Tables 3 and 4 show the expression results of several genes involved in the Na⁺ homeostasis in the plant.

Table 3: Fold increase in gene expression of several genes involved in Na⁺ homeostasis measured in the roots. Smaller values have a green background, whereas higher values have a red background. Values indicate the means±SE of three biological replicas. Expression results were obtained using the $\Delta\Delta$ Ct method.

Accession	<i>HKT1;2</i>	<i>NHX1</i>	<i>NHX2</i>	<i>NHX3</i>	<i>NHX4</i>	<i>AVP3</i>	<i>SOS1</i>	<i>LHA2</i>
Arbasson F1	1.49±0.00	2.16±0.01	2.19±0.12	1.29±0.08	7.67±0.01	1.51±0.15	1.55±0.09	0.73±0.10
LA 1938	4.22±0.04	1.40±0.06	1.22±0.26	1.06±0.02	5.17±0.17	1.45±0.09	1.27±0.07	0.71±0.03
LA 1959	3.90±0.14	1.10±0.04	1.58±0.35	1.25±0.10	3.09±0.01	1.54±0.16	1.14±0.06	1.13±0.20
LA 1325	1.14±0.10	1.42±0.05	0.50±0.05	0.87±0.06	2.18±0.12	0.91±0.03	0.95±0.00	1.45±0.05
LA 2695	0.52±0.03	1.35±0.08	0.76±0.07	0.93±0.07	2.79±0.03	0.97±0.09	1.02±0.21	0.80±0.05
GI 568	5.80±0.43	1.07±0.07	1.21±0.23	1.12±0.12	3.01±0.01	1.48±0.07	1.50±0.12	1.12±0.07
PI 126443	2.86±0.43	1.12±0.05	0.85±0.35	1.22±0.00	3.98±0.39	1.04±0.03	1.25±0.04	0.69±0.06
LA 0532	4.78±0.09	1.35±0.03	0.64±0.08	0.73±0.00	3.08±0.00	0.69±0.07	1.03±0.12	0.90±0.08
LA 0317	1.82±0.40	1.41±0.13	0.24±0.03	0.86±0.06	2.54±0.14	0.89±0.01	1.18±0.04	0.94±0.08
G 1560	4.01±0.90	0.67±0.04	0.55±0.01	0.43±0.00	1.46±0.15	0.62±0.07	1.46±0.16	0.41±0.00
LA 2167	1.30±0.32	1.81±0.16	0.39±0.01	1.00±0.14	5.19±0.28	1.52±0.03	1.39±0.30	1.43±0.18
LA 2860	0.42±0.15	0.81±0.04	2.67±0.09	1.32±0.03	3.66±0.03	1.23±0.01	1.54±0.01	1.96±0.09
PI 126449	2.26±0.01	0.90±0.08	0.91±0.08	1.20±0.11	3.55±0.21	1.01±0.02	1.41±0.12	1.27±0.07
LA 3320	1.10±0.07	1.56±0.07	1.16±0.29	0.85±0.02	3.87±0.02	0.90±0.12	1.23±0.03	0.83±0.13
Abigail F1	0.76±0.22	1.16±0.07	1.10±0.18	0.82±0.07	2.69±0.71	0.88±0.08	1.49±0.07	0.84±0.08
LA 2711	0.44±0.20	2.84±0.14	0.83±0.14	0.90±0.06	1.73±1.20	1.18±0.05	1.46±0.09	1.16±0.10
LA 2194	4.60±0.92	1.44±0.13	1.72±0.10	0.82±0.02	2.12±0.06	1.17±0.09	1.60±0.06	1.19±0.22
LA 1340	3.33±0.76	1.03±0.01	0.63±0.00	1.60±0.17	2.57±0.15	0.87±0.04	1.11±0.01	1.27±0.20
LA 1522	3.22±0.19	1.70±0.32	0.33±0.14	1.35±0.53	5.14±0.80	1.26±0.13	1.45±0.25	1.30±0.31
LA 1302	3.36±0.83	1.21±0.05	0.39±0.11	0.95±0.04	2.82±0.42	0.95±0.04	1.16±0.02	1.11±0.13
LA2548	3.24±0.38	1.30±0.02	0.66±0.20	1.79±0.22	2.89±0.03	1.13±0.09	1.66±0.02	2.61±0.04
OT 2209	2.63±0.15	1.03±0.11	0.55±0.12	1.15±0.01	3.05±0.05	1.07±0.05	1.11±0.02	0.90±0.14
LA 1245	2.84±0.10	1.27±0.02	0.76±0.08	1.58±0.09	3.76±2.03	1.17±0.03	1.36±0.02	1.18±0.11

Table 4: Leaf expression results of several genes involved in Na⁺ homeostasis measured in salt treated plants. Smaller values have a green background, whereas higher values have a red background. Values indicate the means±SE of three biological replicas. Expression results were obtained using the ^{ΔΔ}Ct method.

Accession	Species/Name	P5CS	AVP3	AVP4	NHX1	NHX2
Arbasson F1	<i>S. lycopersicum</i>	1.35±0.15	1.09±0.05	1.18±0.08	2.30±0.31	0.86±0.23
LA 1938	<i>S. chilense</i>	0.57±0.05	0.78±0.13	0.98±0.17	1.28±0.38	0.63±0.11
LA 1959	<i>S. chilense</i>	0.86±0.03	1.50±0.08	1.00±0.00	1.14±0.06	2.22±0.12
LA 1325	<i>S. chmielewskii</i>	1.18±0.03	1.36±0.13	0.98±0.08	1.25±0.23	2.36±0.50
LA 2695	<i>S. chmielewskii</i>	1.08±0.12	1.28±0.01	1.20±0.08	2.52±0.00	2.30±0.11
GI 568	<i>S. corneliomuelleri</i>	1.02±0.20	1.32±0.05	1.47±0.05	1.61±0.16	4.06±0.36
PI 126443	<i>S. corneliomuelleri</i>	1.26±0.05	1.15±0.11	1.49±0.13	2.44±0.23	2.36±0.81
LA 0532	<i>S. galapagense</i>	1.22±0.05	1.44±0.35	1.70±0.08	2.76±0.69	1.22±0.16
LA 0317	<i>S. galapagense</i>	1.71±0.26	1.20±0.02	1.62±0.24	2.66±0.26	1.82±0.90
G 1560	<i>S. habrochaites</i>	0.79±0.06	1.60±0.32	1.47±0.02	1.58±0.26	3.32±0.93
LA 2167	<i>S. habrochaites</i>	1.04±0.20	0.85±0.06	0.96±0.17	1.71±0.26	0.48±0.05
LA 2860	<i>S. habrochaites glabratum</i>	1.46±0.05	1.48±0.06	1.20±0.11	1.71±0.00	1.12±0.05
PI 126449	<i>S. habrochaites glabratum</i>	1.50±0.11	1.19±0.18	1.77±0.01	2.88±0.41	3.33±0.27
LA 3320	<i>S. lycopersicum</i>	1.24±0.11	0.96±0.01	1.17±0.09	2.79±0.01	1.75±0.07
Abigail F1	<i>S. lycopersicum</i>	1.02±0.03	0.84±0.04	1.25±0.16	1.91±0.09	1.32±0.01
LA 2711	<i>S. lycopersicum</i>	1.12±0.03	0.95±0.04	1.18±0.02	1.32±0.17	3.18±0.19
LA 2194	<i>S. neorickii</i>	1.11±0.00	1.55±0.07	1.53±0.04	1.73±0.17	1.62±0.62
LA 1340	<i>S. pennellii</i>	0.58±0.03	0.99±0.23	1.10±0.06	1.48±0.03	0.68±0.06
LA 1522	<i>S. pennellii</i>	0.93±0.05	1.10±0.09	1.37±0.11	2.37±0.13	0.64±0.09
LA 1302	<i>S. pennellii puberulum</i>	0.53±0.05	0.92±0.14	1.30±0.34	2.01±0.57	0.61±0.01
LA2548	<i>S. peruvianum</i>	1.13±0.20	1.36±0.04	1.59±0.26	1.61±0.01	1.84±0.63
OT 2209	<i>S. pimpinellifolium</i>	1.43±0.02	1.32±0.03	1.41±0.01	1.43±0.04	1.69±0.20
LA 1245	<i>S. pimpinellifolium</i>	0.92±0.05	1.47±0.04	1.10±0.02	0.98±0.03	1.53±0.44

Both NHXs expression and Na⁺ accumulation and NHXs and AVPs expression are correlated

NHX transporters have a very important role in salinity tolerance. In tomato, these transporters are responsible for the detoxification of the cytoplasm by pumping Na⁺ into the vacuole [32], for osmotic adjustment by Na⁺ or K⁺ accumulation, or retention of high concentrations of K⁺ in the cell [56]. In conditions of salinity stress, and in the same tissue, higher expression of NHX genes is normally correlated with higher accumulation of ions. And that was also observed in our results. In the roots, higher NHX3 expression was significantly and positively correlated with higher accumulation of Na⁺ (Fig. S8). On the other hand, lower

Na⁺ accumulation in the leaves was correlated with higher *NHX1* expression in the roots (Table 5 and Fig. S8). The results obtained in this study showed some statistically significant positive correlations between *NHX* and *AVP* gene expression (Table 5 and Fig. S9).

***P5CS* expression related to Na⁺ and proline content in the leaves**

As discussed above, proline is an osmolyte of crucial importance during salinity stress events. Consequently, genes involved in the synthesis of proline are obvious targets to be analysed in plant salinity tolerance studies. Here we analysed the Δ^1 -pyrroline-5-carboxylate synthetase (*P5CS*) expression and we compared its expression to both Na⁺ (Fig. S10A) and proline (Fig. S10B) accumulation in the leaves. In the leaves there was a clear link between *P5CS* gene expression, accumulation of proline and accumulation of Na⁺. Higher *P5CS* expression correlated with higher accumulation of proline, and surprisingly, with lower accumulation of Na⁺. This correlation, however, was not observed in the roots (data not shown). As shown in Table 2, all accessions show an increase in proline accumulation when treated with NaCl.

Na⁺ accumulation in the leaves and *HKT1;2* expression in the roots positively correlated

Tomato has two HKT transporters, namely SIHKT1;1 and SIHKT1;2. Both transporters have a serine in the first pore domain which indicates that both transporters are likely involved in Na⁺ transport [22,75]. Interesting, when expressed in yeast cells only SIHKT1;1 was able to deplete Na⁺ from the growth medium [75]. Nevertheless, in this study Na⁺ accumulation in both leaves and stems correlated with *HKT1;2* expression in the roots (Table 5). Figure 3 shows in more detail the correlation between Na⁺ accumulation in the leaves and the expression of *HKT1;2* in the roots (done using the $\Delta\Delta$ Ct protocol). From the 23 accessions studied, LA 2695, LA 2860, Abigail and LA 2711 showed a reduction in the root *HKT1;2* expression when treated with NaCl (Table 3). In the leaves, *HKT1;2* expression and Na⁺ accumulation was not correlated (data not shown). In contrast to *HKT1;2*, both *HKT1;1* and *SOS1* expression significantly and positively correlated with Na⁺ accumulation in the roots (Fig. S7C and S7D). *SOS1* and *LHA7* (Fig. S7D) but not *LHA2* and *LHA9* (data not shown) expression in the roots were correlated (Table 5). This is interesting because, although no clear correlation existed between *SOS1* and *LHA2* or *LHA7* and Na⁺ accumulation in the roots, a significant and positive correlation existed between the accumulation of Na⁺ and *LHA2* expression in the roots (Fig. S7E).

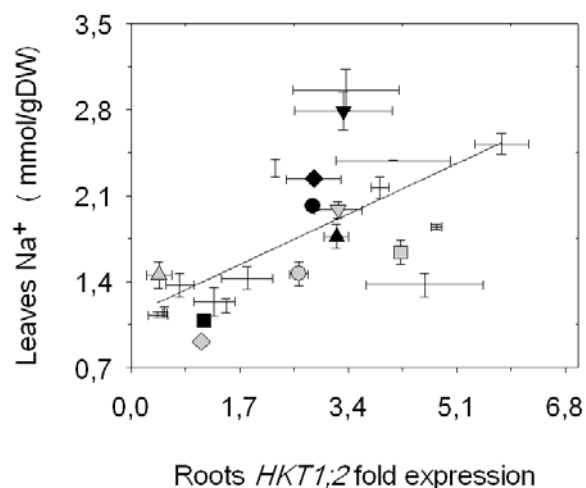

Figure 3: Na⁺ accumulation in the leaves and its correlation with *HKT1;2* expression in the roots. Black symbols represent the five accessions with higher PTI values: LA 1325 (■), PI 126443 (◆), LA 1522 (▲), LA 1340 (▼) and LA 1245 (●). Grey symbols represent the five accessions with lower PTI values: LA 1938 (■), LA 3320 (◆), LA 2711 (▲), LA 2548 (▼) and OT 2209 (●). Values indicate the means±SE of three biological replicas. The Spearman correlation coefficient was used. This correlation is statistically significant.

Correlation analysis and PCA

Due to the great variation observed in all parameters measured in the accessions studied and also to the statistically significant correlations observed among some of these parameters (Table 5) we decided to perform a Principal Component Analysis (PCA), shown in Fig. 4. With this analysis we aimed to reveal the real contribution of these correlations to the difference in salinity tolerance observed in Table 1.

Table 5: Linear correlation coefficients between different ion concentrations measured in leaf, stem and root tissue of salt treated plants, proline concentration measured in the leaves of salt treated plants, and gene expression of several genes involved in the transport of Na⁺ in the cells. Ion and proline concentrations used in these correlations were measured only in salt treated samples. Proline was only measured in leaf tissue. Asterisks show statistically significant correlations, $p < 0.05$.

	Leaf Na ⁺	Stem Na ⁺	Root Na ⁺	Proline	Root <i>LHA7</i>	Leaf <i>AVP4</i>	Leaf <i>AVP3</i>	Root <i>AVP3</i>
Leaf Cl ⁻	0.419*							
Stems Cl ⁻		0.493*						
Root <i>HKT1;2</i>	0.414*	0.188*						
Root <i>HKT1;1</i>			0.308*					
Root <i>SOS1</i>					0.230*			
Root <i>LHA2</i>			0.363*					
Root <i>NHX1</i>	0.189*							
Root <i>NHX3</i>			0.259*					0.181*
Root <i>NHX2</i>								0.200*
Root <i>NHX4</i>								0.363*
Leaf <i>NHX1</i>						0.313*		
Leaf <i>NHX2</i>								0.163*
Leaf <i>P5CS</i>	0.271*			0.205*				

The patterns of the variables co-variation are shown by PCA and eigenvectors representing the strength (shown by the length of the vector) and direction of the trait correlation in relation to the first two principal components (PCs) (Fig. 4). Both principal components accounted for 44.7% of the total variance. Both Na⁺/K⁺ ratio and Na⁺ concentrations were explained by the major PC1. In this component sucrose, Cl⁻ and *HKT1;1* expression were also strongly associated. *SOS1*, *NHX1*, *P5CS* and *LHA2* expression and proline accumulation were explained by the PC2 as they did not significantly contribute to other PCs.

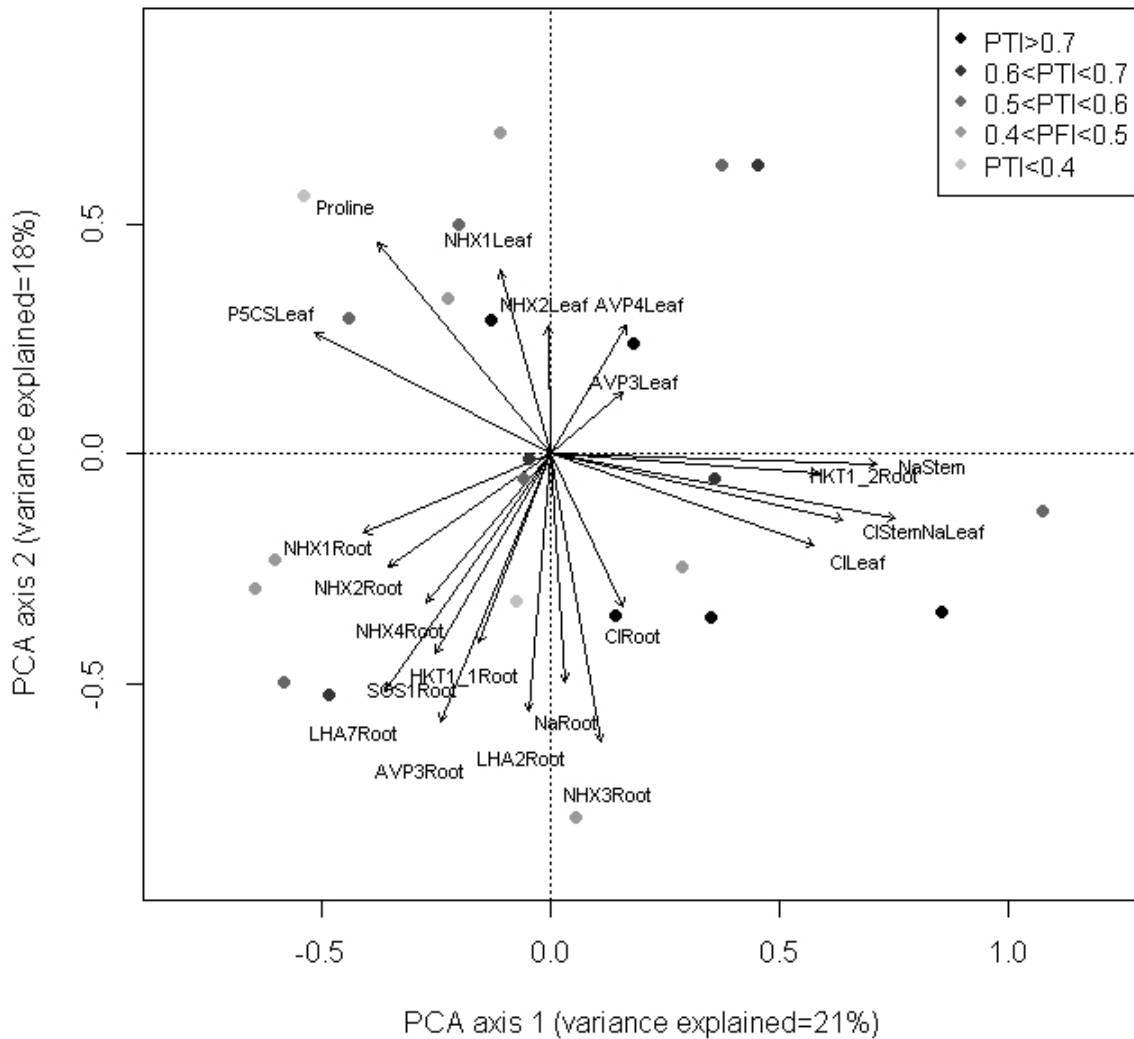

Figure 4: Two axes of a principal component (PC1 and PC2) analysis showing the position of several physiological parameters. Arrows indicate eigenvectors representing the strength and direction of the trait correlation relative to the first two principal components (PC1 and PC2). Dots indicate the PTI values of the accessions analysed in this study.

Discussion

Salinity tolerance does not correlate with Na⁺ exclusion in the shoots

Soil salinity is a worldwide problem affecting the yield of several crop species [1]. For several crop species, salinity tolerance has been linked to an effective Na⁺ exclusion from the shoots [6,57-61]. Accumulation or exclusion of Na⁺ from the shoots under saline conditions is based on the capacity of the plant to reduce the uptake of this ion [62]. Excessive accumulation of

Na⁺ in saline conditions results in the disruption of ion homeostasis *in planta* [49]. In tomato, the control of Na⁺ accumulation in the shoot may be important in enhancing salt tolerance [63,64]. Nevertheless, some studies have been published showing that the link between Na⁺ exclusion from the shoots and salinity tolerance is not as clear as previously thought. For instance, in wheat and *Arabidopsis* no clear relationship between Na⁺ exclusion and salinity tolerance exists [8,23,65]. In fact, two *Arabidopsis thaliana* ecotypes – Tsu1 and Ts – having low expression of *HKT1;1* accumulated more Na⁺ in the shoots than ecotypes with higher *HKT1;1* expression [23]. Nevertheless, Tsu1 and Ts ecotypes were more salt tolerant than the ecotypes that accumulated less Na⁺ in the shoots [23].

Similarly, in this study no correlation was observed between Na⁺ accumulation, in any of the tissues analysed, and tolerance to salt. These results showed that, at a given level of Na⁺ exclusion, a wide range of salinity tolerance can exist. Consequently, Na⁺ exclusion and similar levels of salinity tolerance among a range of genotypes can occur due to different combinations of tissue tolerance and Na⁺ exclusion [65]. From these results we conclude that in tomato the role of whole-plant Na⁺ exclusion in salinity tolerance is overrated in comparison to other cellular mechanisms. These mechanisms are most likely related to tissue tolerance [65]. It is likely that Na⁺-exclusion and tissue tolerance (i.e. the capacity to sequester Na⁺ in the vacuoles) work independently, making salinity tolerance depending on their relative effects [65], rather than on one of these mechanisms alone.

The division of shoots into stems and leaves and the independent analysis of Na⁺ and K⁺ concentrations in these tissues did not bring forward any relationship between higher salinity tolerance and any specific pattern of tissue specific Na⁺ and K⁺ accumulation. Interestingly, both accessions with high and low PTI scores were able to maintain concentrations of K⁺ when treated with NaCl in all tissues analysed. This was the case for LA 1325, LA 3320 and OT 2209. With the exception of Edkawi, which is able to maintain its K⁺ concentration, and *S. pennellii*, which even increases it under salt treatment, all other tomato accessions tend to show reduced concentrations of K⁺ when treated with NaCl [66].

In a study with *Arabidopsis* ecotypes, slower growth rates seem to correlate with increased salinity tolerance [8]. In this way, accessions with slower growth in control conditions show higher salinity tolerance when growing under salinity stress conditions [8]. This was also observed in this study. Almost all accessions showing high PTI values were slow growers (Table 1). LA 1522 was an exception as this accession is a fast grower and scored a high PTI value. Slow growth means reduced transpiration and reduced water and consequently, Na⁺ uptake via the roots, which might allow more time and better Na⁺ partitioning in the shoots.

This suggests that, more than Na⁺ exclusion, mechanisms involved in Na⁺ tissue tolerance might play an important role in salinity tolerance in tomato species. Among these mechanisms, efficient compartmentation in the vacuole and/or increased accumulation of osmoprotectant compounds [1] might have an important role in tomato salinity tolerance.

***P5CS*, proline and sucrose accumulation**

In this study a positive correlation between the expression of *P5CS* and the accumulation of proline in the leaves was observed. Analysis of the accessions individually, showed that both tolerant and sensitive accessions had the same amount of proline present in the leaves. This agrees with the literature. Both studies reporting high accumulation of proline in tolerant [49,67,68] and sensitive [69] accessions have been published. Proline accumulation was also related to lower concentrations of Na⁺ in the leaves. In situations of salinity stress, the normal plant response is to accumulate high concentrations of proline in response to high concentrations of Na⁺. In this study, however, the opposite was observed. As a compatible osmolyte, proline and its role in response to salinity stress is one of the most widely studied mechanisms [49]. For a long period, proline was considered to be a good trait in the selection of salt tolerant genotypes. Several studies showed that salt tolerant plants accumulated higher levels of proline in response to salinity treatments than salt sensitive ones [67,68]. Nowadays, this idea is not as widely accepted as it was previously. Some studies showed the opposite. Working with tomato, Aziz et al. [70] reported a negative correlation between salt tolerance and proline accumulation. Tal et al. [69] obtained similar results. Also Juan et al. [49] reported that proline accumulation and biomass production were not related. The same result was observed in our study. Despite the significant increase in proline accumulation due to the salinity treatment shown by all accessions studied, no correlation between proline and PTI was observed. This showed that, although proline accumulation is a common response to salinity stress, it is not, *per se*, the driving force for salinity tolerance in tomato.

There is also some controversy about the role of sugars in salinity tolerance [49]. Despite a reduction in net CO₂ assimilation during salinity stress [50,71], a higher accumulation of soluble sugars in stressed plants has been widely reported. Nevertheless, in a study by Ashraf [72], this was not confirmed. Juan et al. [49] showed that the highest and lowest accumulations of sucrose were observed in the most and in the least tolerant cultivars, respectively. The same authors referred that Na⁺ and Cl⁻ concentrations as well as biomass, correlated with the concentration of sucrose [49]. In our study, despite the significant increases in sucrose accumulation observed in all accessions, no correlation between sucrose

and PTI or Na⁺ or Cl⁻ was observed. In fact, both OT 2209 and LA 1245, which were the accessions with the lowest and highest PTI score, showed the same sucrose accumulation.

The role of genes involved in Na⁺ homeostasis

***HKT1;1, HKT1;2, SOS1 and LHA* genes**

Several studies showed the role of AtHKT1;1 in reducing the amount of shoot Na⁺ accumulation via the retrieval of Na⁺ from the xylem cells [14,15,24,73], and via the recirculation from the shoots to the roots via the phloem [13]. Overexpression of *AtHKT1;1* [15] as well as *athkt1;1* mutant plants [74] showed that HKT1;1 reduces the Na⁺ accumulated in the shoots.

In this study a positive relationship between root *HKT1;2* expression and the concentrations of Na⁺ measured in the leaves and in the stems but not roots was observed. In the roots, the expression of *HKT1;1* and the accumulation of Na⁺ were correlated. These results can be considered surprising as tomato *HKT1;2* sequence is more similar to *AtHKT1;1* than tomato *HKT1;1* [75]. And also because *AtHKT1;1* expression in the roots is associated with lower Na⁺ accumulation in the shoots [8,15]. Interestingly, both accessions with the highest and lowest PTI scores, LA 1245 and OT 2209, respectively, showed similar *HKT1;2* expression in the roots but different Na⁺ accumulation in the shoots. In the case of *HKT1;1* the two accessions with the higher PTI values showed reduced *HKT1;1* expression in the roots when treated with salt. Nevertheless, these two accessions showed different behaviours in terms of Na⁺ accumulated in the roots as LA 1245 accumulated more Na⁺ than PI 126443. In a work by Rus et al. [23] the correlation between weak *HKT1;1* alleles of two *Arabidopsis thaliana* ecotypes and higher Na⁺ accumulation in the shoots was described, although in this case these two ecotypes had also high Na⁺ accumulation [23] in contrast to the tomato ecotypes from this study which show low Na⁺ accumulation. However, the results obtained with *HKT1;1* have to be interpreted with care. When expressed in *Xenopus laevis* oocytes, SIHKT1;1 did not produce any measurable currents, in contrast to the results presented by Asins et al. [75] who reported that, when expressed in yeast cells, SIHKT1;1 but not SIHKT1;2, could deplete the Na⁺ present in the growing medium.

AtSOS1 is a plasma membrane located Na⁺/H⁺ antiporter transporting Na⁺ out of the cell [25] and expressed all over the epidermal root tissue [76]. *SOS1* is also expressed along the vascular tissue [25], allowing the pumping of Na⁺ into the transpiration stream. In comparison to *AtHKT1;1*, which high expression in the roots resulted in lower Na⁺ accumulation in the shoots [8], high expression of *SOS1* resulted in lower total plant Na⁺ [31]. In this study, in the

roots, higher *SOS1* expression correlated with higher Na^+ accumulation. Like the results for *HKT1;2* these results obtained for *SOS1* were also surprising. This might be explained by the need to pump more Na^+ out of the cells of stressed plants, via loading of Na^+ into the xylem.

At the plasma membrane, the presence of P-type ATPases, encoded by the *LHA* gene family, creates the proton motif force necessary to energise the extrusion of Na^+ [35], via *SOS1*. Here we observed a positive correlation between *SOS1* and *LHA7* expression in the roots as well as a positive correlation between *LHA2* and Na^+ accumulation in the roots. This suggests that *SOS1* is energized by *LHA7* but not *LHA2*. This is interesting in the context of a study by Maathuis et al. [38] who refer that the energization of Na^+/H^+ extrusion at the root soil boundary is likely to be driven by *LHA2*.

***NHXs* and *AVPs* genes**

In this study we observed that the higher expression, in the roots, of *NHX1* and *NHX3* correlated with the lower accumulation of Na^+ in the leaves and higher accumulation of Na^+ in the roots, respectively. This agrees with some previously published results as *NHX1* is involved in Na^+ sequestration in the vacuole [35], and *NHX3* being predominantly expressed in root tissue [38]. However, these results are contrasting to those obtained by Villalta et al. [52] who mapped *SINHX3* to a QTL related to Na^+ accumulation in the leaves. Although Villalta et al. [77] reported that *SINHX1* was associated with a QTL for Cl^- concentration in young leaves, we did not find a clear correlation between *SINHX1* expression and Cl^- accumulation in the leaves. This might have been due the fact that in this study we did not separate young from old leaves. Interesting was also the fact that *SINHX2* expression did not correlate with the K^+ concentration in any of the tissues analysed in this study, albeit its ubiquitous expression pattern [78]. *Solanum sp* *NHX2* did not contribute to Na^+ accumulation [78], although a weak, non-significant correlation between *NHX2* expression in the roots and Na^+ accumulation in the stems and leaves was observed (data not-shown). This might have happened due to some indirect effect of *NHX2* in K^+ accumulation, which in turn, affected Na^+ accumulation in the aerial parts of the plants. As expected, *NHXs* expression levels positively correlated with *AVPs* expression. Although *AVP* does not have a direct role in Na^+ homeostasis its ability to create a proton gradient between the vacuole and the cytosol [1] can fuel the activity of *NHX* [8,38,41].

In conclusion, the fact that several correlations between the different genes analysed and between different genes and ions and proline accumulation were observed, showed that plants share some general strategies to face salinity stress. However, when a more detailed analysis

was done it became clear that accessions with high and low PTI scores showed the same concentrations of ions and proline measured and the same gene(s) expression levels. This revealed that for a particular level of salinity tolerance a complex ratio between Na⁺ exclusion and tissue tolerance defines the salinity tolerance of individual tomato accessions.

Limitations of this study

In our study, the fact that several accessions from different species are being compared adds an extra degree of difficulty trying to understand common mechanisms of salinity tolerance. Besides, changes in gene expression are not always correlated with changes in the protein produced. Also, the fact that we used a long period of stress might have made it difficult to bring forward important differences in gene expression, as several genes return their gene expression levels to control levels after 4 days under salt stress. Like previously referred by Jha et al. the activity of individual transporters can not be explained by changes in gene expression, and it can happen that ecotypes have more effective versions of Na⁺ transporters, or regulators of these proteins. One such example might be the CBL/CIPK Ca²⁺ signalling pathway [8].

Supplemental information:

Table S1: Primers used in qRT-PCR studies.

Primer Name	Primer Sequence (from 5' to 3')
<i>SILHA2 F6</i>	AGAGAAGAGCAGAGATGGCA
<i>SILHA2 R6</i>	ACCTTTCAGCTTCACCACTGATT
<i>SILHA7 F4</i>	CTTGGTGGCTACTTGGCAAT
<i>SILHA7 R4</i>	GATAGTGCTTACTTGAAGGT
<i>SILHA9 F7</i>	GAGCTAATTGAAAAGGCAGATGG
<i>SILHA9 R7</i>	ATCATTCACTCCATCTCCTG
<i>SISOS1 F6</i>	CCAACCTGCTAAAGTCGTCATTG
<i>SISOS1 R6</i>	CTTGTCTTGTAATCGCGTGTGTG
<i>SINHX1 F7</i>	ACAGTGGTGTGTTGGGCTGATAAC
<i>SINHX1 R7</i>	TGAAACCTTGTGATGAAGGCAAC
<i>SLAVP2 F3</i>	GTGCAGCTTTGAAGATGGTTGAG
<i>SLAVP2 R3</i>	TTAGCATGACCTTCCATGAGACC
<i>SLAVP3 F3</i>	TGGAATGAGCCACAGAATCA
<i>SLAVP3 R3</i>	ATTGCACCGACTAGCAGACC
<i>SLAVP4 F1</i>	GCTACAACCAAGGGATTTGC
<i>SLAVP4 R1</i>	AGTTCGACCAACAGCTGCAC
<i>SINHX3 F2</i>	AGGGGAGGCCATACTCAGTT
<i>SINHX3 R7</i>	TACCCCTGTGCTGAAAAGGA
<i>SINHX4 F3</i>	CCACCACAGAGGCAATTGAG
<i>SINHX4 R7</i>	AGGAGTGGGGCTGTTAGAGA
<i>SINHX2 R7</i>	GGAGACGAAGATGAAGATG
<i>SINHX2 F7</i>	CCTTTGAGGGGAACAATGG
<i>SIHKT1 R7</i>	CCAGCATGCCTTGTATTAC
<i>Slβ-actine F</i>	AAAAGTGCGAGTGTCTGTCT
<i>Slβ-actine R</i>	TCAAAAAACAAATTGACTGG

Table S2: Table 4: Na⁺, K⁺, Cl⁻ and Na⁺/K⁺ and concentrations in the (A) roots, (B) stems and (C) leaves of 23 tomato accessions grown in rockwool plugs soaked with Hoagland's solution for 3 weeks before treated to either 0 or 100 mM NaCl for 2 weeks. Values indicate the means±SE of three biological replicas. The asterisks indicate significant differences according to One-way ANOVA (**p*<0.05).

A)

Accession	PTI (FWshoots salt/ FWshoots control)	Treat. (mM NaCl)	Roots [Na ⁺]	Roots [K ⁺]	Roots Na ⁺ /K ⁺	Roots [Cl ⁻]
Arbasson F1	0.46±0.06	0	0.50±0.01	1.44±0.01	0.35±0.01	0.39±0.03
		100	1.46±0.03*	1.06±0.01*	1.38±0.02*	1.57±0.01*
LA 1938	0.37±0.05	0	0.25±0.03	1.16±0.08	0.22±0.03	0.17±0.00
		100	1.80±0.11*	1.12±0.04	1.60±0.07*	1.32±0.17*
LA 1959	0.48±0.08	0	0.48±0.02	0.87±0.04	0.56±0.02	0.28±0.01
		100	1.43±0.05*	0.72±0.04	2.00±0.11*	1.75±0.11*
LA 1325	0.71±0.14	0	0.55±0.02	1.12±0.03	0.49±0.02	0.28±0.02
		100	1.50±0.09*	1.00±0.05	1.51±0.09*	0.80±0.05*
LA 2695	0.53±0.06	0	0.66±0.04	1.06±0.03	0.62±0.05	0.76±0.07
		100	1.56±0.05*	1.41±0.10*	1.11±0.06*	1.20±0.13*
GI 568	0.66±0.12	0	0.29±0.02	1.08±0.03	0.27±0.03	0.30±0.01
		100	1.36±0.04*	0.71±0.05*	1.93±0.17*	1.12±0.12*
PI 126443	0.71±0.13	0	0.42±0.01	1.20±0.04	0.36±0.01	0.43±0.00
		100	1.50±0.09*	1.35±0.07	1.11±0.07*	1.95±0.30*
LA 0532	0.50±0.06	0	0.38±0.02	1.23±0.04	0.31±0.02	0.13±0.03
		100	1.30±0.07*	1.96±0.11*	0.67±0.06*	1.13±0.01*
LA 0317	0.50±0.06	0	0.36±0.02	1.11±0.01	0.33±0.02	0.18±0.01
		100	1.59±0.10*	1.26±0.12	1.28±0.09*	0.78±0.11*
G 1560	0.60±0.09	0	0.39±0.04	1.53±0.02	0.25±0.03	0.33±0.04
		100	1.51±0.04*	0.84±0.06*	1.82±0.12*	1.42±0.08*
LA 2167	0.67±0.08	0	0.55±0.02	0.94±0.03	0.58±0.01	0.18±0.01
		100	2.04±0.08*	0.67±0.04*	3.05±0.21*	1.71±0.01*
LA 2860	0.56±0.05	0	0.44±0.00	1.06±0.02	0.42±0.00	0.28±0.00
		100	1.95±0.11*	0.97±0.05	2.02±0.19*	1.09±0.02*
PI 126449	0.65±0.08	0	0.37±0.01	1.12±0.04	0.33±0.01	0.15±0.02
		100	2.46±0.16*	1.48±0.10*	1.68±0.15*	0.81±0.09*
LA 3320	0.39±0.08	0	0.68±0.02	1.13±0.03	0.60±0.00	0.30±0.01
		100	1.59±0.09*	1.40±0.18	1.16±0.10*	1.27±0.04*
Abigail F1	0.57±0.13	0	0.39±0.04	1.13±0.04	0.34±0.04	0.45±0.00
		100	1.36±0.08*	1.23±0.06	1.11±0.02*	1.17±0.10*
LA 2711	0.43±0.07	0	0.58±0.05	1.28±0.04	0.46±0.05	0.35±0.02
		100	1.40±0.01*	1.49±0.09	0.94±0.06*	1.32±0.06*
LA 2194	0.54±0.11	0	0.49±0.05	0.87±0.06	0.56±0.02	0.40±0.06
		100	2.00±0.14*	0.97±0.06	2.08±0.12*	0.95±0.10*
LA 1340	0.77±0.12	0	0.23±0.02	1.20±0.03	0.19±0.02	0.24±0.04
		100	1.87±0.10*	1.50±0.11	1.25±0.05*	1.37±0.13*
LA 1522	0.76±0.12	0	0.44±0.02	1.35±0.05	0.33±0.02	0.21±0.02
		100	1.96±0.14*	1.56±0.12	1.27±0.07*	0.98±0.05*
LA 1302	0.57±0.16	0	0.27±0.01	1.54±0.04	0.18±0.01	0.50±0.04
		100	1.62±0.12*	1.49±0.08	1.08±0.03*	1.94±0.27*
LA 2548	0.44±0.04	0	0.59±0.04	1.54±0.08	0.38±0.01	0.29±0.04
		100	2.30±0.10*	1.49±0.08	1.55±0.02*	2.47±0.20*
OT 2209	0.44±0.05	0	0.44±0.02	0.87±0.02	0.50±0.02	0.38±0.03
		100	1.24±0.03*	0.71±0.09	1.79±0.23*	1.07±0.01*
LA 1245	0.98±0.11	0	0.32±0.02	1.15±0.04	0.28±0.03	0.40±0.01
		100	2.05±0.05*	1.68±0.10*	1.24±0.10*	0.80±0.01*

Table S2: Continuation.

B)

Accession	PTI (FWshoots salt/ FWshoots control)	Treat. (mM NaCl)	Stems [Na ⁺]	Stems [K ⁺]	Stems Na ⁺ /K ⁺	Stems [Cl ⁻]
Arbasson F1	0.46±0.06	0	0.92±0.02	2.72±0.01	0.34±0.01	0.52±0.02
		100	2.28±0.10*	2.10±0.08	1.08±0.03*	1.77±0.00*
LA 1938	0.37±0.05	0	1.06±0.03	2.37±0.11	0.45±0.03	0.35±0.02
		100	1.83±0.03*	1.90±0.07*	0.97±0.03*	1.96±0.04*
LA 1959	0.48±0.08	0	1.06±0.01	2.03±0.05	0.52±0.02	0.55±0.00
		100	2.51±0.10*	1.49±0.07*	1.68±0.04*	2.56±0.13*
LA 1325	0.71±0.14	0	0.60±0.02	1.94±0.08	0.31±0.01	0.25±0.04
		100	1.84±0.17*	1.86±0.06	0.99±0.06*	1.48±0.06*
LA 2695	0.53±0.06	0	0.50±0.05	2.81±0.04	0.18±0.01	0.13±0.02
		100	1.95±0.02*	2.87±0.12	0.68±0.03*	2.04±0.08*
GI 568	0.66±0.12	0	1.19±0.06	2.12±0.04	0.56±0.02	0.34±0.01
		100	2.42±0.10*	1.25±0.04*	1.94±0.04*	2.31±0.01*
PI 126443	0.71±0.13	0	0.96±0.01	1.64±0.03	0.58±0.01	0.41±0.04
		100	2.48±0.09*	1.44±0.06*	1.73±0.04*	1.77±0.05*
LA 0532	0.50±0.06	0	1.30±0.09	2.67±0.12	0.49±0.05	0.18±0.00
		100	3.67±0.17*	1.74±0.08*	2.11±0.15*	1.92±0.02*
LA 0317	0.50±0.06	0	1.17±0.05	2.40±0.09	0.49±0.00	0.60±0.07
		100	2.49±0.04*	2.16±0.05	1.15±0.04*	2.23±0.07*
G 1560	0.60±0.09	0	1.02±0.02	2.94±0.12	0.35±0.01	0.51±0.05
		100	2.55±0.13*	1.86±0.02*	1.37±0.07*	2.07±0.04*
LA 2167	0.67±0.08	0	0.61±0.05	2.46±0.08	0.25±0.02	0.42±0.01
		100	1.64±0.11*	1.46±0.09*	1.12±0.03*	1.66±0.21*
LA 2860	0.56±0.05	0	0.40±0.00	2.54±0.04	0.16±0.00	0.30±0.02
		100	1.36±0.02*	2.19±0.06*	0.62±0.01*	1.90±0.09*
PI 126449	0.65±0.08	0	0.83±0.00	2.21±0.04	0.37±0.00	0.32±0.03
		100	2.66±0.01*	2.35±0.07	1.14±0.03*	1.60±0.12*
LA 3320	0.39±0.08	0	0.78±0.03	2.47±0.07	0.32±0.01	0.47±0.01
		100	1.79±0.09*	2.36±0.03	0.76±0.04*	1.49±0.04*
Abigail F1	0.57±0.13	0	0.78±0.04	1.70±0.02	0.46±0.03	0.57±0.07
		100	1.54±0.05*	1.48±0.15	1.06±0.11*	1.49±0.12*
LA 2711	0.43±0.07	0	1.11±0.06	2.30±0.05	0.48±0.04	0.47±0.02
		100	1.93±0.11*	1.94±0.04*	1.00±0.06*	1.19±0.00*
LA 2194	0.54±0.11	0	0.56±0.03	2.95±0.05	0.19±0.01	0.38±0.02
		100	1.54±0.03*	2.38±0.10*	0.65±0.03*	2.03±0.06*
LA 1340	0.77±0.12	0	1.43±0.07	2.79±0.03	0.51±0.03	0.58±0.02
		100	4.35±0.06*	2.54±0.08*	1.72±0.03*	2.72±0.26*
LA 1522	0.76±0.12	0	1.56±0.04	2.38±0.05	0.65±0.02	0.22±0.08
		100	2.61±0.18*	1.69±0.10*	1.56±0.20*	2.69±0.14*
LA 1302	0.57±0.16	0	1.64±0.08	2.85±0.04	0.57±0.02	0.53±0.03
		100	4.30±0.08*	2.01±0.03*	2.14±0.05*	5.11±0.70*
LA 2548	0.44±0.04	0	0.83±0.05	2.29±0.02	0.36±0.02	0.29±0.02
		100	2.45±0.05*	1.59±0.02*	1.54±0.03*	1.97±0.05*
OT 2209	0.44±0.05	0	0.50±0.06	1.69±0.14	0.30±0.01	0.33±0.00
		100	1.39±0.06*	1.76±0.08	0.79±0.06*	1.33±0.10*
LA 1245	0.98±0.11	0	1.61±0.02	1.77±0.09	0.92±0.04	0.55±0.01
		100	2.62±0.14*	1.43±0.05*	1.84±0.08*	2.08±0.09*

Table S2: Continuation.

C)

Accession	PTI (FWshoots salt/ FWshoots control)	Treat. (mM NaCl)	Leaves [Na ⁺]	Leaves [K ⁺]	Leaves Na ⁺ /K ⁺	Leaves [Cl ⁻]
Arbasson F1	0.46±0.06	0	0.36±0.02	1.50±0.06	0.24±0.00	0.23±0.01
		100	1.21±0.06*	1.34±0.02*	0.90±0.03*	0.66±0.06*
LA 1938	0.37±0.05	0	0.34±0.03	1.62±0.06	0.21±0.01	0.26±0.04
		100	1.64±0.10*	1.31±0.04*	1.26±0.11*	0.88±0.01*
LA 1959	0.48±0.08	0	0.36±0.05	1.37±0.01	0.26±0.03	0.16±0.00
		100	2.16±0.09*	1.13±0.03*	1.91±0.07*	1.66±0.06*
LA 1325	0.71±0.14	0	0.22±0.00	1.48±0.02	0.15±0.00	0.09±0.01
		100	1.09±0.03*	1.53±0.10	0.72±0.05*	1.08±0.02*
LA 2695	0.53±0.06	0	0.22±0.00	1.13±0.01	0.20±0.00	0.24±0.00
		100	1.15±0.05*	1.22±0.02*	0.94±0.06*	0.67±0.10*
GI 568	0.66±0.12	0	0.54±0.03	1.39±0.10	0.39±0.02	0.22±0.01
		100	2.52±0.09*	1.27±0.04	1.98±0.04*	1.38±0.01*
PI 126443	0.71±0.13	0	0.60±0.02	1.29±0.02	0.47±0.02	0.23±0.04
		100	2.24±0.04*	1.22±0.04	1.83±0.05*	1.62±0.03*
LA 0532	0.50±0.06	0	0.41±0.05	1.36±0.06	0.31±0.05	0.16±0.02
		100	1.85±0.02*	0.93±0.07*	2.01±0.16*	1.07±0.00*
LA 0317	0.50±0.06	0	0.45±0.07	1.43±0.00	0.32±0.05	0.17±0.00
		100	1.43±0.09*	1.22±0.07*	1.17±0.07*	1.03±0.04*
G 1560	0.60±0.09	0	0.83±0.03	1.25±0.03	0.66±0.03	0.09±0.00
		100	2.38±0.00*	0.90±0.03*	2.65±0.09*	0.96±0.05*
LA 2167	0.67±0.08	0	0.35±0.02	1.60±0.03	0.22±0.02	0.18±0.01
		100	1.24±0.12*	1.23±0.04*	1.02±0.13*	0.75±0.02*
LA 2860	0.56±0.05	0	0.23±0.02	1.32±0.05	0.18±0.01	0.26±0.03
		100	1.13±0.02*	1.04±0.05*	1.10±0.05*	1.17±0.01*
PI 126449	0.65±0.08	0	0.72±0.02	1.28±0.07	0.57±0.04	0.21±0.00
		100	2.32±0.07*	0.93±0.01*	2.50±0.05*	1.35±0.03*
LA 3320	0.39±0.08	0	0.35±0.03	1.53±0.04	0.23±0.02	0.19±0.02
		100	0.91±0.02*	1.49±0.06	0.62±0.02*	0.84±0.02*
Abigail F1	0.57±0.13	0	0.30±0.02	1.39±0.04	0.21±0.02	0.11±0.01
		100	1.37±0.10*	1.55±0.03*	0.88±0.04*	0.55±0.01*
LA 2711	0.43±0.07	0	0.30±0.02	1.61±0.05	0.19±0.02	0.25±0.01
		100	1.45±0.11*	1.46±0.03	1.00±0.08*	1.02±0.00*
LA 2194	0.54±0.11	0	0.33±0.01	1.43±0.05	0.23±0.01	0.21±0.05
		100	1.37±0.10*	1.44±0.05	0.95±0.04*	1.12±0.00*
LA 1340	0.77±0.12	0	0.52±0.05	1.55±0.07	0.33±0.02	0.26±0.03
		100	2.79±0.15*	1.27±0.02*	2.20±0.11*	1.75±0.14*
LA 1522	0.76±0.12	0	0.62±0.04	1.31±0.07	0.47±0.02	0.27±0.02
		100	1.77±0.10*	1.13±0.03	1.56±0.09*	1.51±0.08*
LA 1302	0.57±0.16	0	0.58±0.03	1.35±0.02	0.43±0.02	0.10±0.00
		100	2.96±0.17*	1.33±0.07	2.23±0.11*	1.77±0.06*
LA 2548	0.44±0.04	0	0.53±0.03	1.22±0.01	0.43±0.02	0.17±0.01
		100	1.98±0.07*	0.92±0.03*	2.16±0.03*	0.69±0.04*
OT 2209	0.44±0.05	0	0.30±0.02	1.36±0.05	0.22±0.01	0.12±0.03
		100	1.46±0.10*	1.31±0.03	1.11±0.07*	0.90±0.05*
LA 1245	0.98±0.11	0	0.45±0.03	1.21±0.03	0.37±0.02	0.29±0.03
		100	2.02±0.02*	1.22±0.04	1.65±0.05*	2.30±0.00*

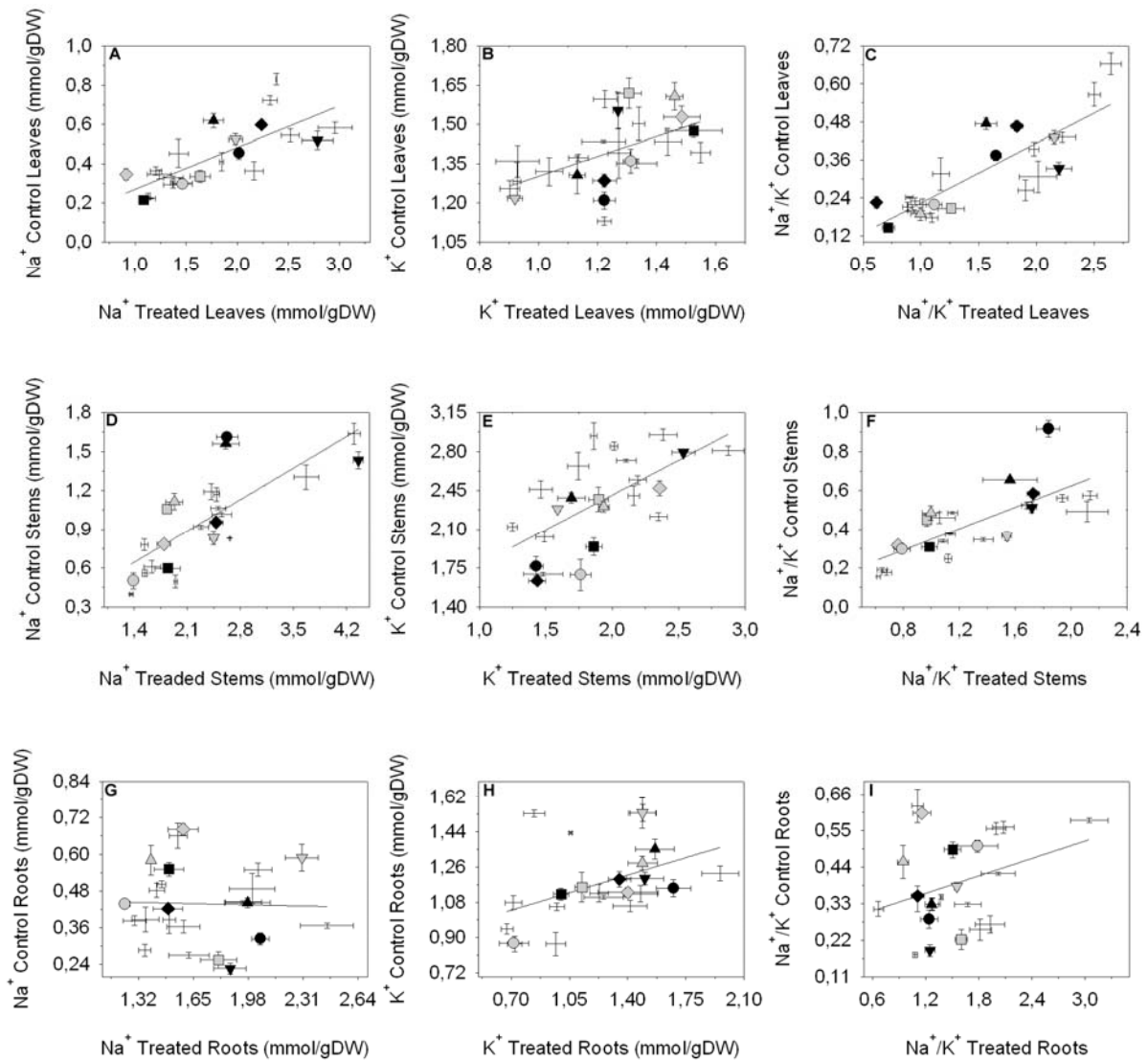

Figure S1: Correlation of Na^+ concentration (A, D, G), K^+ concentration (B, E, H) and Na^+/K^+ ratio (C, F, I) between control and salt treated leaves (A to C), stems (D to F) and roots (G to I). Black symbols represent the five accessions with higher PTI values: LA 1325 (■), PI 126443 (◆), LA 1522 (▲), LA 1340 (▼) and LA 1245 (●). Grey symbols represent the five accessions with lower PTI values: LA 1938 (■), LA 3320 (◆), LA 2711 (▲), LA 2548 (▼) and OT 2209 (●). Values indicate the means \pm SE of three biological replicates. Values indicate the means \pm SE of three biological replicates. With the exception of control stem [Na^+] vs salt treated stem [Na^+], which was tested using the Spearman correlation coefficient, all the other correlations were treated using the Pearson correlation coefficient. Except control root [Na^+] vs salt treated root [Na^+] and control root Na^+/K^+ vs salt treated root Na^+/K^+ , which did not show statistically significant correlations, all the other correlations were statistically significant.

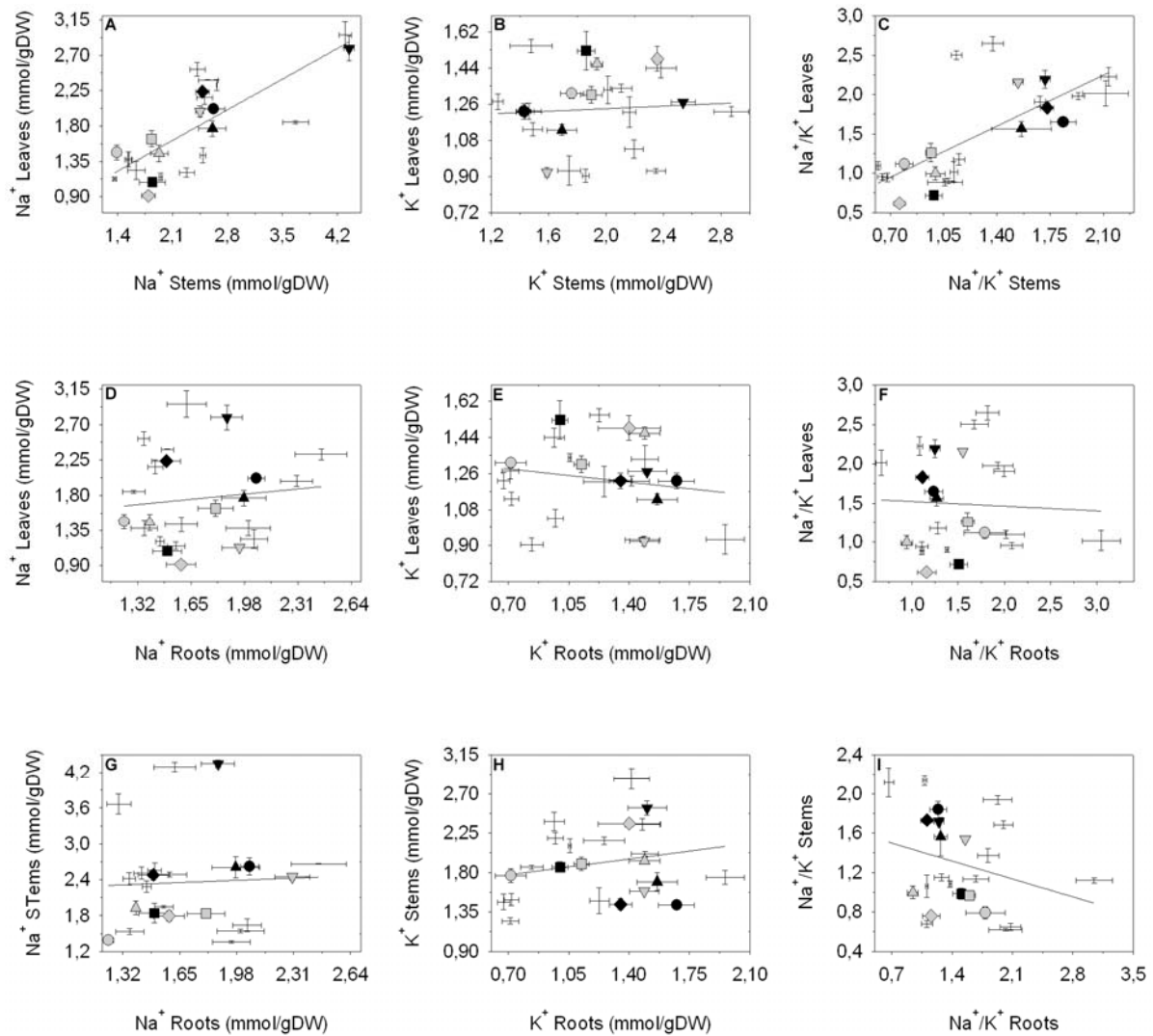

Figure S2: Correlation of Na⁺ concentration (A, D, G), K⁺ concentration (B, E, H) and Na⁺/K⁺ ratio (C, F, I) between salt treated leaves and salt treated stems (A to C), salt treated leaves and salt treated roots (D to F) and salt treated stems and salt treated roots (G to I). Black symbols represent the five accessions with higher PTI values: LA 1325 (■), PI 126443 (◆), LA 1522 (▲), LA 1340 (▼) and LA 1245 (●). Grey symbols represent the five accessions with lower PTI values: LA 1938 (■), LA 3320 (◆), LA 2711 (▲), LA 2548 (▼) and OT 2209 (●). Values indicate the means±SE of three biological replicas. Values indicate the means±SE of three biological replicas. With the exception of leaves [Na⁺] vs stems [Na⁺], leaves Na⁺/K⁺ vs stems Na⁺/K⁺ and stems Na⁺/K⁺ vs roots Na⁺/K⁺, which were tested using the Spearman correlation coefficient, all the other correlations were treated using the Pearson correlation coefficient.

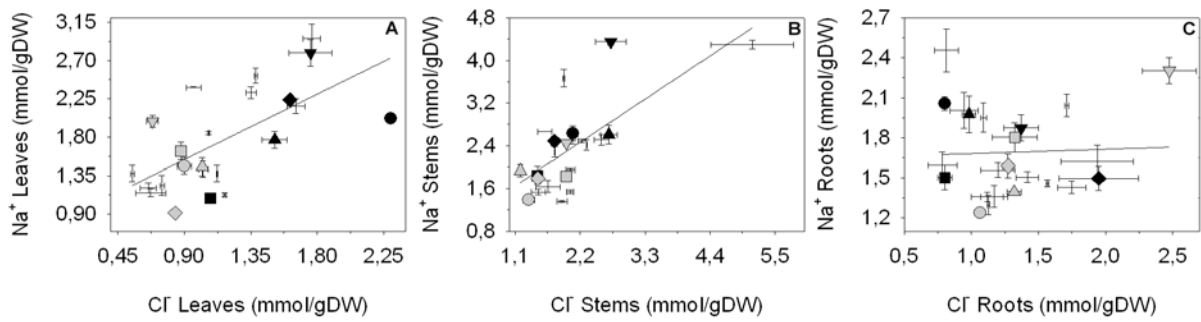

Figure S3: Correlation between the concentration of Na^+ and Cl^- in salt treated (A) leaves, (B) stems and (C) roots. Black symbols represent the five accessions with higher PTI values: LA 1325 (■), PI 126443 (◆), LA 1522 (▲), LA 1340 (▼) and LA 1245 (●). Grey symbols represent the five accessions with lower PTI values: LA 1938 (■), LA 3320 (◆), LA 2711 (▲), LA 2548 (▼) and OT 2209 (●). Values indicate the means \pm SE of three biological replicas. Values indicate the means \pm SE of three biological replicas. Leaves $[\text{Na}^+]$ vs leaves $[\text{Cl}^-]$ and stems $[\text{Na}^+]$ vs stems $[\text{Cl}^-]$ were tested using the Spearman correlation coefficient. Roots $[\text{Na}^+]$ vs roots $[\text{Cl}^-]$ was tested using the Pearson correlation coefficient. Leaves $[\text{Na}^+]$ vs leaves $[\text{Cl}^-]$ and stems $[\text{Na}^+]$ vs stems $[\text{Cl}^-]$ show statistically significant correlations. Roots $[\text{Na}^+]$ vs roots $[\text{Cl}^-]$ does not show statistically significant correlation.

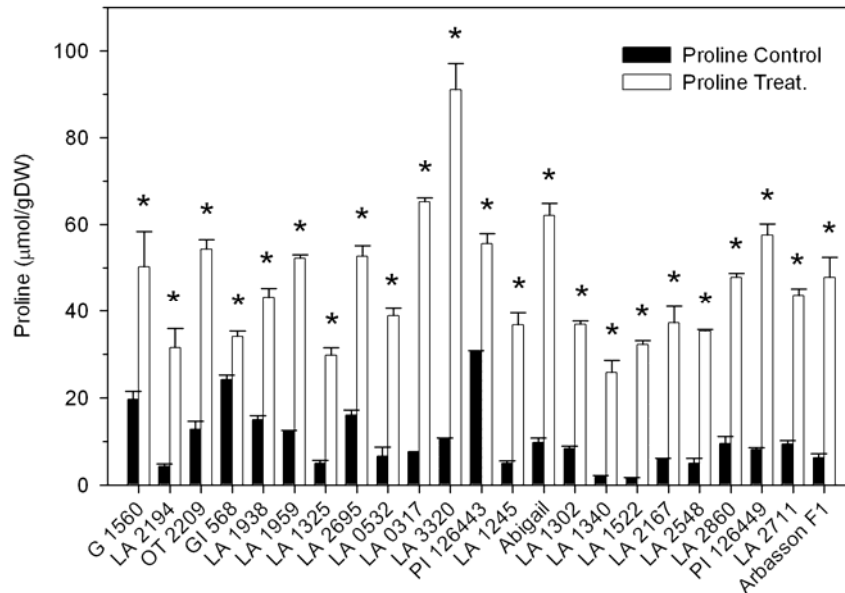

Figure S4: Proline accumulation shows significant increases between leaves of control plants (white bars) and leaves of salt treated plants (black bars). Values indicate the means \pm SE of three biological replicas. All increments in proline accumulation are significant according to Student's *t*-test ($p < 0.05$).

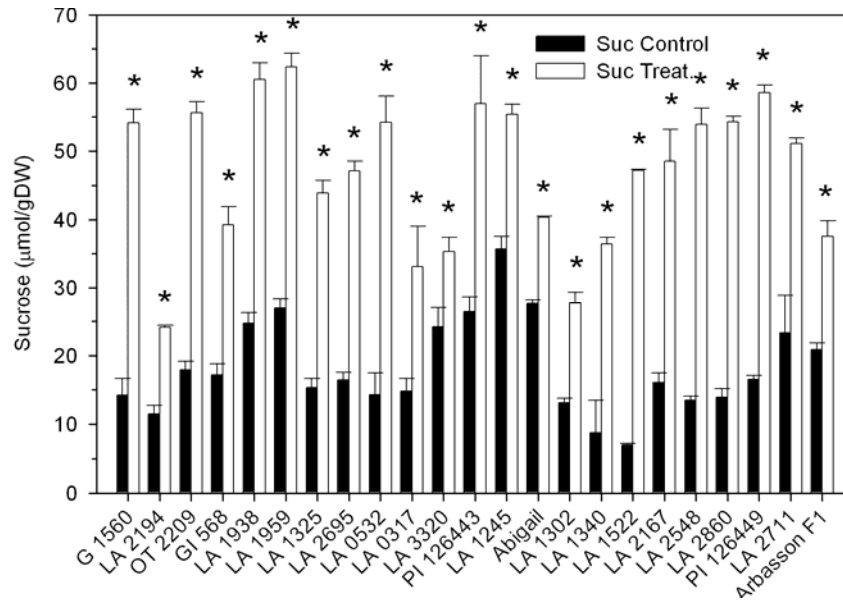

Figure S5: Tomato accessions treated with 100 mM NaCl for two weeks show an increase in concentration of sucrose in the leaves. Values indicate the means \pm SE of three biological replicas. All increments in sucrose accumulation are significant according to Student's *t*-test ($p < 0.05$).

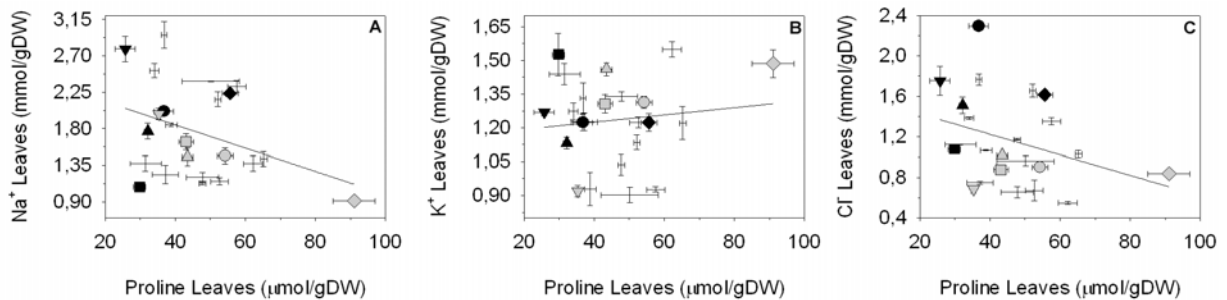

Figure S6: Correlation between (A) Na⁺, (B) K⁺, and (C) Cl⁻ and proline concentrations in leaves of tomato plants treated with 100 mM NaCl for two weeks. Black symbols represent the five accessions with higher PTI values: LA 1325 (■), PI 126443 (◆), LA 1522 (▲), LA 1340 (▼) and LA 1245 (●). Grey symbols represent the five accessions with lower PTI values: LA 1938 (■), LA 3320 (◆), LA 2711 (▲), LA 2548 (▼) and OT 2209 (●). Values indicate the means \pm SE of three biological replicas. All correlations tested using the Spearman correlation coefficient. No statistical significant correlations were found.

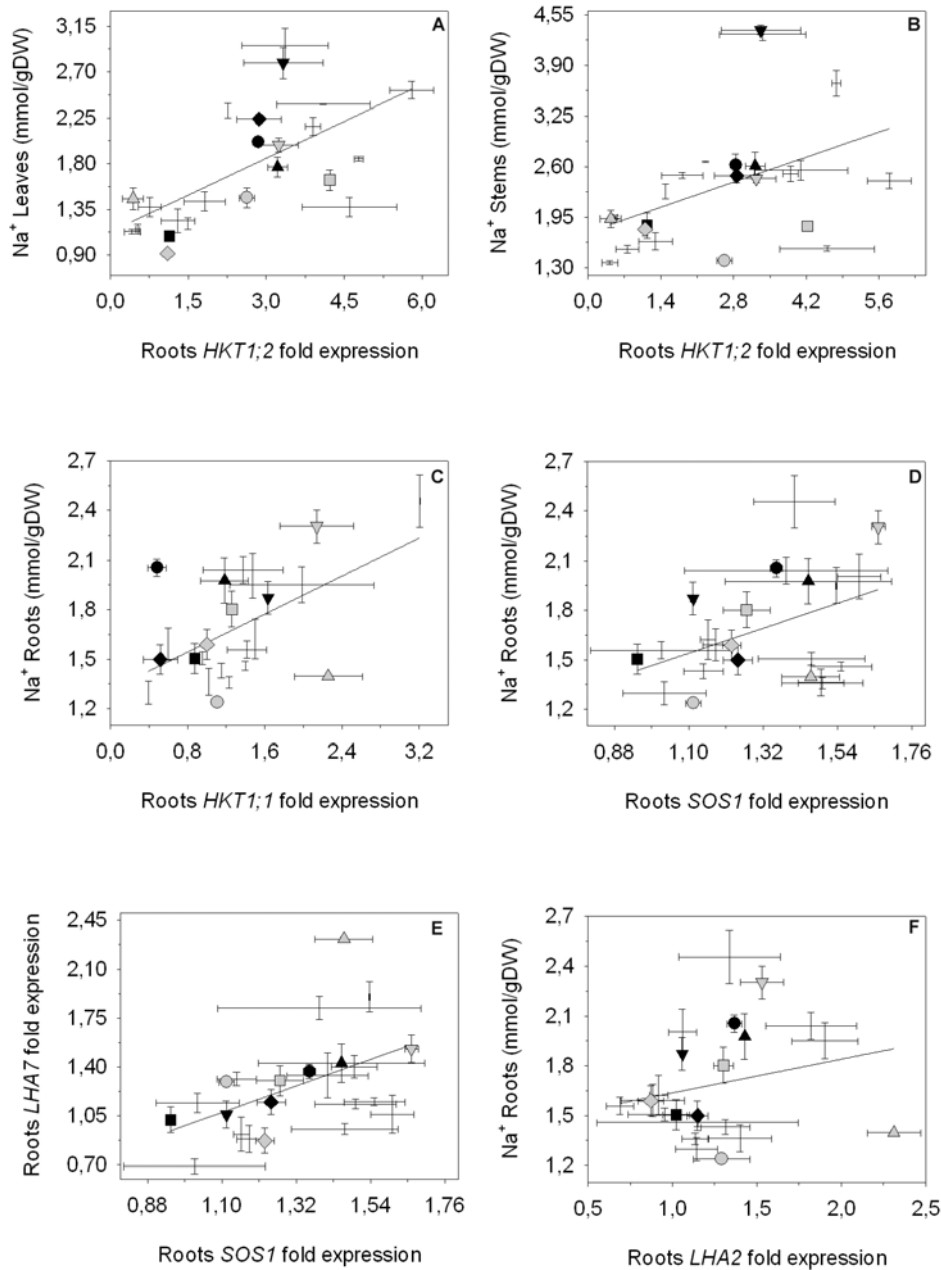

Figure S7: Na⁺ accumulation in the (A) leaves and (B) in the stems and its correlation with *HKT1;2* and (C) *HKT1;1* expression in the roots, (D) Na⁺ accumulation in the roots and its correlation with *SOS1* expression in the roots, (E) *LHA7* and *SOS1* expression in the roots, (F) Na⁺ accumulation and *LHA2* expression in the roots. Black symbols represent the five accessions with higher PTI values: LA 1325 (■), PI 126443 (◆), LA 1522 (▲), LA 1340 (▼) and LA 1245 (●). Grey symbols represent the five accessions with lower PTI values: LA 1938 (■), LA 3320 (◆), LA 2711 (▲), LA 2548 (▼) and OT 2209 (●). Values indicate the means±SE of three biological replicas. The Pearson correlation coefficient was used in (C) and (D) and the Spearman correlation coefficient was used in (A), (B) and (E). All correlation are statistically significant.

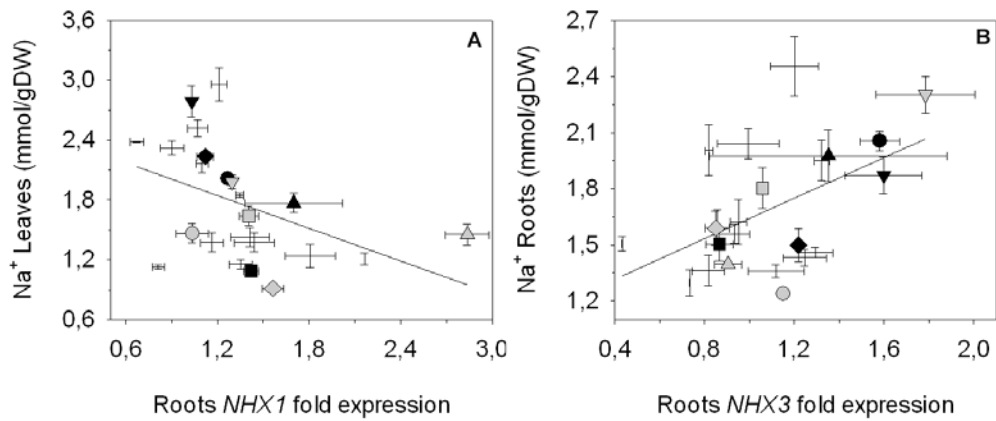

Figure S8: Correlations between (A) Na⁺ accumulation in the leaves and *NHX1* expression in the roots and (B) Na⁺ accumulation in the roots and *NHX3* expression in the roots. Black symbols represent the five accessions with higher PTI values: LA 1325 (■), PI 126443 (◆), LA 1522 (▲), LA 1340 (▼) and LA 1245 (●). Grey symbols represent the five accessions with lower PTI values: LA 1938 (■), LA 3320 (◆), LA 2711 (▲), LA 2548 (▼) and OT 2209 (●). Values indicate the means±SE of three biological replicates. Values indicate the means±SE of three biological replicates. Correlations (A) tested using the Spearman correlation coefficient. Correlations (D) tested using the Pearson correlation coefficient. Both correlations are statistical significant.

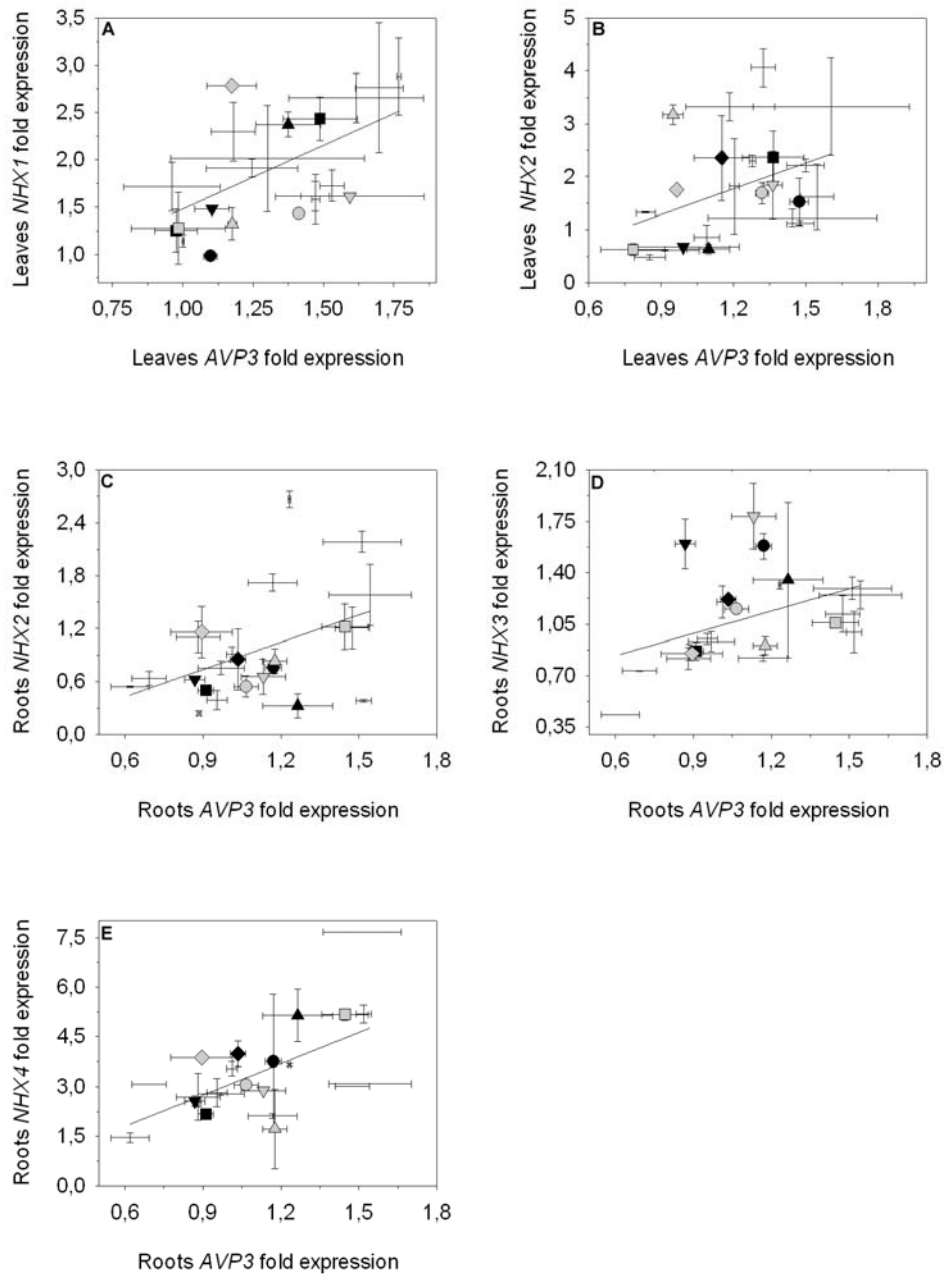

Figure S9: Correlations between the expression of (A) *NHX1* and *AVP4* in the leaves; (B) *NHX2* and *AVP3* in the leaves; (C) *NHX2* and *AVP3* in the roots; (D) *NHX3* and *AVP3* in the roots; and (E) *NHX4* and *AVP3* in the roots. Black symbols represent the five accessions with higher PTI values: LA 1325 (■), PI 126443 (◆), LA 1522 (▲), LA 1340 (▼) and LA 1245 (●). Grey symbols represent the five accessions with lower PTI values: LA 1938 (◻), LA 3320 (◊), LA 2711 (▲), LA 2548 (▼) and OT 2209 (●). Values indicate the means±SE of three biological replicas. Values indicate the means±SE of three biological replicas. All correlations tested using the Pearson correlation coefficient. All correlations are statistical significant.

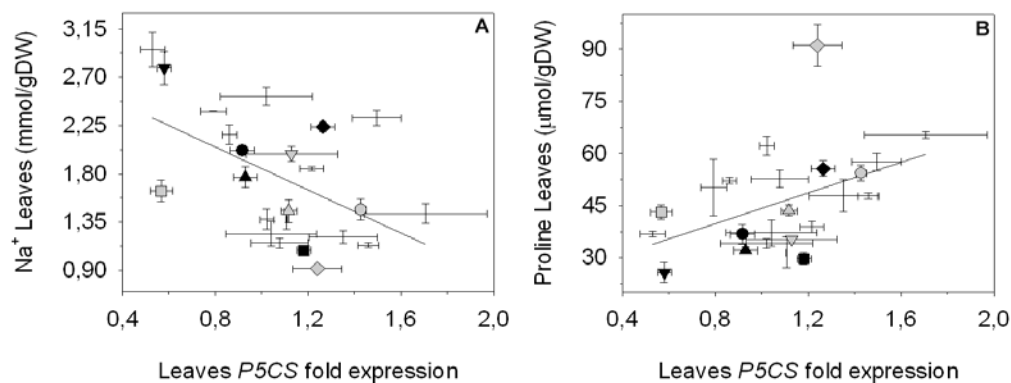

Figure S10: Relationship between the concentration of (A) Na⁺ and (B) proline and *P5CS* gene expression in the leaves. Black symbols represent the five accessions with higher PTI values: LA 1325 (■), PI 126443 (◆), LA 1522 (▲), LA 1340 (▼) and LA 1245 (●). Grey symbols represent the five accessions with lower PTI values: LA 1938 (■), LA 3320 (◆), LA 2711 (▲), LA 2548 (▼) and OT 2209 (●). Values indicate the means±SE of three biological replicates. Both correlations tested using the Pearson correlation coefficient. Both correlations are statistically significant.

References

- Munns R, Tester M (2008) Mechanisms of salinity tolerance. *Annual Review of Plant Biology* 59: 651-681.
- FAO (2009) FAO land and plant nutrition management service. www.fao.org/ag/agl/agll/spush/.
- Manaa A, Ahmed HB, Valot B, Bouchet JP, Aschi-Smiti S, et al. (2011) Salt and genotype impact on plant physiology and root proteome variations in tomato. *Journal of Experimental Botany* 62: 2797-2813.
- Tester M, Davenport R (2003) Na⁺ tolerance and Na⁺ transport in higher plants. *Annals of Botany* 91: 503-527.
- Laurie S, Feeney KA, Maathuis FJM, Heard PJ, Brown SJ, et al. (2002) A role for HKT1 in sodium uptake by wheat roots. *Plant Journal* 32: 139-149.
- Munns R, James RA (2003) Screening methods for salinity tolerance: a case study with tetraploid wheat. *Plant and Soil* 253: 201-218.
- Parida AK, Das AB (2005) Salt tolerance and salinity effects on plants: a review. *Ecotoxicology and Environmental Safety* 60: 324-349.
- Jha D, Shirley N, Tester M, Roy SJ (2010) Variation in salinity tolerance and shoot sodium accumulation in *Arabidopsis* ecotypes linked to differences in the natural expression levels of transporters involved in sodium transport. *Plant Cell and Environment* 33: 793-804.
- Prior LD, Grieve AM, Bevington KB, Slavich PG (2007) Long-term effects of saline irrigation water on "Valencia" orange trees: relationships between growth and yield, and salt levels in soil and leaves. *Australian Journal of Agricultural Research* 58: 349-358.
- El-Hendawy SE, Hu Y, Schmidhalter U (2004) Growth, ion content, gas exchange, and water relations of wheat genotypes differing in salt tolerances. *Australian Journal of Agricultural Research* 56: 123-134.
- Genc Y, McDonald GK, Tester M (2007) Reassessment of tissue Na⁺ concentration as a criterion for salinity tolerance in bread wheat. *Plant, Cell and Environment* 30: 1486-1498.
- Uozumi N, Kim EJ, Rubio F, Yamaguchi T, Muto S, et al. (2000) The *Arabidopsis* *HKT1* gene homolog mediates inward Na⁺ currents in *Xenopus laevis* oocytes and Na⁺ uptake in *Saccharomyces cerevisiae*. *Plant Physiology* 122: 1249-1259.

13. Berthomieu P, Conejero G, Nublat A, Brackenbury WJ, Lambert C, et al. (2003) Functional analysis of *AtHKT1* in *Arabidopsis* shows that Na⁺ recirculation by the phloem is crucial for salt tolerance. *EMBO Journal* 22: 2004-2014.
14. Davenport RJ, Munoz-Mayor A, Jha D, Essah PA, Rus A, et al. (2007) The Na⁺ transporter *AtHKT1;1* controls retrieval of Na⁺ from the xylem in *Arabidopsis*. *Plant Cell and Environment* 30: 497-507.
15. Moller IS, Gilliam M, Jha D, Mayo GM, Roy SJ, et al. (2009) Shoot Na⁺ exclusion and increased salinity tolerance engineered by cell type-specific alteration of Na⁺ transport in *Arabidopsis*. *Plant Cell* 21: 2163-2178.
16. Ren ZH, Gao JP, Li LG, Cai XL, Huang W, et al. (2005) A rice quantitative trait locus for salt tolerance encodes a sodium transporter. *Nature Genetics* 37: 1141-1146.
17. Jabnour M, Espeout S, Mieulet D, Fizames C, Verdeil JL, et al. (2009) Diversity in expression patterns and functional properties in the rice HKT transporter family. *Plant Physiology* 150: 1955-1971.
18. Yao X, Horie T, Xue SW, Leung HY, Katsuhara M, et al. (2010) Differential sodium and potassium transport selectivities of the rice *OsHKT2;1* and *OsHKT2;2* transporters in plant cells. *Plant Physiology* 152: 341-355.
19. Fairbairn DJ, Liu WH, Schachtman DP, Gomez-Gallego S, Day SR, et al. (2000) Characterisation of two distinct HKT1-like potassium transporters from *Eucalyptus camaldulensis*. *Plant Molecular Biology* 43: 515-525.
20. Mian A, Oomen RJ, Isayenkow S, Sentenac H, Maathuis FJ, et al. (2011) Overexpression of a Na⁺ and K⁺-permeable HKT transporter in barley improves salt tolerance. *Plant Journal* 68: 468-479.
21. Ali Z, Park HC, Ali A, Oh D-H, Aman R, et al. (2012) *TsHKT1;2*, a HKT1 homolog from the extremophile *Arabidopsis* relative *Thellungiella salsuginea*, shows K⁺ specificity in the presence of NaCl. *Plant Physiology* 158: 1463-1474.
22. Platten JD, Cotsaftis O, Berthomieu P, Bohnert H, Davenport RJ, et al. (2006) Nomenclature for HKT transporters, key determinants of plant salinity tolerance. *Trends in Plant Science* 11: 372-374.
23. Rus A, Baxter I, Muthukumar B, Gustin J, Lahner B, et al. (2006) Natural variants of *AtHKT1* enhance Na⁺ accumulation in two wild populations of *Arabidopsis*. *PloS Genetics* 2: 1964-1973.
24. Plett D, Safwat G, Gilliam M, Moller IS, Roy S, et al. (2010) Improved salinity tolerance of rice through cell type-specific expression of *AtHKT1;1*. *PloS One* 5.
25. Shi H, Ishitani M, Kim CS, Zhu JK (2000) The *Arabidopsis thaliana* salt tolerance gene *SOS1* encodes a putative Na⁺/H⁺ antiporter. *Proceedings of the National Academy of Sciences USA* 97: 6896-6901.
26. Zhu JK (2002) Salt and drought stress signal transduction in plants. *Annual Review in Plant Biology* 53: 247-273.
27. Zhu JK (2003) Regulation of ion homeostasis under salt stress. *Current Opinion Plant Biology* 6: 441-445.
28. Ishitani M, Liu J, Halfter U, Kim CS, Shi W, et al. (2000) SOS3 function in plant salt tolerance requires N-myristoylation and calcium binding. *The Plant Cell* 12: 1667-1678.
29. Halfter U, Ishitani M, Zhu JK (2000) The *Arabidopsis* SOS2 protein kinase physically interacts with and is activated by the calcium-binding protein SOS3. *Proceedings of the National Academy of Sciences USA* 97: 3735-3740.
30. Shi HZ, Quintero FJ, Pardo JM, Zhu JK (2002) The putative plasma membrane Na⁺/H⁺ antiporter *SOS1* controls long-distance Na⁺ transport in plants. *Plant Cell* 14: 465-477.
31. Shi HZ, Lee BH, Wu SJ, Zhu JK (2003) Overexpression of a plasma membrane Na⁺/H⁺ antiporter gene improves salt tolerance in *Arabidopsis thaliana*. *Nature Biotechnology* 21: 81-85.
32. Gaxiola R, Rao R, Sherman A, Grisafi P, Alper SL, et al. (1999) The *Arabidopsis thaliana* proton transporters, *AtNHX1* and *AVP1*, can function in cation detoxification in yeast. *Proceedings of the National Academy of Sciences USA* 96: 1480-1485.
33. Zhang HX, Blumwald E (2001) Transgenic salt-tolerant tomato plants accumulate salt in foliage but not in fruit. *Nature Biotechnology* 19: 765-768.

34. Xue Z-Y, Zhi D-Y, Xue G-P, Zhang H, Zhao Y-X, et al. (2004) Enhanced salt tolerance of transgenic wheat (*Triticum aestivum* L.) expressing a vacuolar Na⁺/H⁺ antiporter gene with improved grain yields in saline soils in the field and a reduced level of leaf Na⁺. *Plant Science* 167: 849-859.
35. Apse MP, Aharon GS, Snedden WA, Blumwald E (1999) Salt tolerance conferred by overexpression of a vacuolar Na⁺/H⁺ antiport in *Arabidopsis*. *Science* 285: 1256-1258.
36. He C, Yan J, Shen G, Fu L, Holaday AS, et al. (2005) Expression of an *Arabidopsis* vacuolar sodium/proton antiporter gene in cotton improves photosynthetic performance under salt conditions and increases fiber yield in the field. *Plant and Cell Physiology* 46: 1848-1854.
37. Chen H, An R, Tang JH, Cui XH, Hao FS, et al. (2007) Overexpression of a vacuolar Na⁺/H⁺ antiporter gene improves salt tolerance in an upland rice. *Molecular Breeding* 19: 215-225.
38. Maathuis FJ, Filatov V, Herzyk P, Krijger GC, Axelsen KB, et al. (2003) Transcriptome analysis of root transporters reveals participation of multiple gene families in the response to cation stress. *The Plant Journal* 35: 675-692.
39. Palmgren MG, Harper JF (1999) Pumping with plant P-type ATPases. *Journal of Experimental Botany* 50: 883-893.
40. Palmgren MG, Nissen P (2011) P-type ATPases. *Annual Review in Biophysics* 40: 243-266.
41. Gaxiola R, Li J, Undurraga S, Dang LM, Allen GJ, et al. (2001) Drought- and salt-tolerant plants result from overexpression of the AVP1 H⁺-pump. *Proceedings of the Natural Academy of Sciences, USA*: 11444-11449.
42. Conde A, Chaves MM, Geros H (2011) Membrane transport, sensing and signaling in plant adaptation to environmental stress. *Plant and Cell Physiology* 52: 1583-1602.
43. Fujita T, Maggio A, Garcia-Rios M, Bressan RA, Csonka LN (1998) Comparative analysis of the regulation of expression and structures of two evolutionary divergent genes for Δ 1-pyrroline-5-carboxylate synthetase from tomato. *Plant Physiology* 118: 661-674.
44. Hmida-Sayari A, Gargouri-Bouزيد R, Bidani A, Jaoua L, Savoure A, et al. (2005) Overexpression of Δ 1-pyrroline-5-carboxylate synthetase increases proline production and confers salt tolerance in transgenic potato plants. *Plant Science* 169: 746-752.
45. Silva-Ortega CO, Ochoa-Alfaro AE, Reyes-Aguero JA, Aguado-Santacruz GA, Jimenez-Bremont JF (2008) Salt increases the expression of *P5CS* gene and induces proline accumulation in cactus pear. *Plant Physiology and Biochemistry* 46: 82-92.
46. Hu CA, Delauney AJ, Verma DPS (1992) A bifunctional enzyme (Δ 1-pyrroline-5-carboxylate synthetase) catalyzes the first two steps in proline biosynthesis in plants. *Proceedings of the Natural Academy of Sciences USA* 89: 9354-9358.
47. Yoshida Y, Kiyosue T, Katagiri T, Ueda H, Mizoguchi T, et al. (1995) Correlation between the induction of a gene for Δ 1-pyrroline-5-carboxylate synthetase and the accumulation of proline in *Arabidopsis thaliana* under osmotic stress. *The Plant Journal* 7: 751-760.
48. Igarashi Y, Yoshida Y, Sanada Y, Yamaguchi-Shinozaki K, Wada K, et al. (1997) Characterization of the gene for Δ -pyrroline-5-carboxylate synthetase and correlation between the expression of the gene and salt tolerance in *Oryza sativa* L. *Plant Molecular Biology* 33: 857-865.
49. Juan M, Rivero RM, Romero L, Ruiz JM (2005) Evaluation of some nutritional and biochemical indicators in selecting salt-tolerant tomato cultivars. *Environmental and Experimental Botany* 54: 193-201.
50. Murakozy EP, Nagy Z, Duhaze C, Bouchereau A, Tuba Z (2003) Seasonal changes in the levels of compatible osmolytes in three halophytic species of inland saline vegetation in Hungary. *Journal of Plant Physiology* 160: 395-401.
51. Popp M, Smirnov N (1995) Polyol accumulation and metabolism during water deficit. In: Smirnov N, editor. *Environment and plant metabolism: flexibility and acclimation*. Oxford: Bios Scientific. pp. 199-215.
52. Villalta I, Reina-Sanchez A, Bolarin MC, Cuartero J, Belver A, et al. (2008) Genetic analysis of Na⁺ and K⁺ concentrations in leaf and stem as physiological components of salt tolerance in tomato. *Theoretical and Applied Genetics* 116: 869-880.
53. Miller JC, Tanksley SD (1990) RFLP analysis of phylogenetic relationships and genetic variation in the genus *Lycopersicon*. *Theoretical and Applied Genetics* 80: 437-448.

54. Bates LS, Waldren RP, Teare ID (1973) Rapid determination of free proline for water stress studies. *Plant and Soil* 39: 205-207.
55. Livak KJ, Schmittgen TD (2001) Analysis of relative gene expression data using real-time quantitative PCR and the 2- $\Delta\Delta$ CT method. *Methods* 25: 402-408.
56. Galvez FJ, Baghour M, Hao G, Cagnac O, Rodriguez-Rosales MP, et al. (2012) Expression of *LeNHX* isoforms in response to salt stress in salt sensitive and salt tolerant tomato species. *Plant Physiology and Biochemistry* 51: 109-115.
57. Gorham J, Bristol A, Young EM, Jones RGW, Kashour G (1990) Salt tolerance in the *Triticeae* - K^+/Na^+ discrimination in barley. *Journal of Experimental Botany* 41: 1095-1101.
58. Schachtman DP, Munns R (1992) Sodium accumulation in leaves of *Triticum* species that differ in salt tolerance. *Functional Plant Biology* 19: 331-340.
59. Forster B (2001) Mutation genetics of salt tolerance in barley: an assessment of Golden Promise and other semi-dwarf mutants. *Euphytica* 120: 317-328.
60. Zhu GY, Kinet JM, Lutts S (2001) Characterization of rice (*Oryza sativa* L.) F3 populations selected for salt resistance. I. Physiological behaviour during vegetative growth. *Euphytica* 121: 251-263.
61. Garthwaite AJ, von Bothmer R, Colmer TD (2005) Salt tolerance in wild *Hordeum* species is associated with restricted entry of Na^+ and Cl^- into the shoots. *Journal of Experimental Botany* 56: 2365-2378.
62. Koval VS, Koval SF (1996) Genetic analysis of salt tolerance in barley-identification of number of genes. *Genetica* 32: 1098-1103.
63. Perez-Alfocea F, Balibrea ME, Santa-Cruz A, Estan MT (1996) Agronomical and physiological characterization of salinity tolerance in a commercial tomato hybrid. *Plant and Soil* 180: 251-257.
64. Cuartero J, Fernandez-Munoz R (1999) Tomato and salinity. *Scientia Horticulturae* 78: 83-125.
65. Genc Y, Oldach K, Verbyla A, Lott G, Hassan M, et al. (2010) Sodium exclusion QTL associated with improved seedling growth in bread wheat under salinity stress. *Theoretical and Applied Genetics*.
66. Bolarin MC, Santa-Cruz A, Cayuela E, Perez-Alfocea F (1995) Short-term solute changes in leaves and roots of cultivated and wild tomato seedling under salinity. *Journal of Plant Physiology* 147: 463-468.
67. Jain S, Nainawatee HS, Jain RK, Chowdhury JB (1991) Proline status of genetically stable salt-tolerant *Brassica juncea* L. somaclones and their parent cv. "Parkash". *Plant Cell Reports* 9: 684-687.
68. Kirti PB, Hadi S, Chopra VL (1991) Seed transmission of salt tolerance in regenerants of *Brassica juncea* selected *in vitro*. *Cruciferae Newsletter* 85: 14-15.
69. Tal M, Katz A, Heiken H, Dehan K (1979) Salt tolerance in the wild relatives of the cultivated tomato: proline accumulation in *Lycopersicon esculentum* Mill., *L. peruvianum* Mill, and *Solanum pennellii* Cor. treated with NaCl and polyethyleneglycol. *New Phytologist* 82: 349-360.
70. Aziz A, Martin-Tanguy J, Larher F (1998) Stress-induced changes in polyamine and tyramine levels can regulate proline accumulation in tomato leaf discs treated with sodium chloride. *Physiology Plantarum* 104: 195-202.
71. Ashraf M, Harris PJ (2004) Potential biochemical indicators of salinity tolerance in plants. *Plant Science* 166: 3-16.
72. Ashraf M (1997) Changes in soluble carbohydrates and soluble proteins in three arid-zone grass species under salt stress. *Tropical Agriculture* 74: 234-237.
73. Sunarpi, Horie T, Motoda J, Kubo M, Yang H, et al. (2005) Enhanced salt tolerance mediated by AtHKT1 transporter-induced Na^+ unloading from xylem vessels to xylem parenchyma cells. *Plant Journal* 44: 928-938.
74. Rus A, Lee BH, Munoz-Mayor A, Sharkhuu A, Miura K, et al. (2004) AtHKT1 facilitates Na^+ homeostasis and K^+ nutrition in planta. *Plant Physiology* 136: 2500-2511.
75. Asins JM, Villalta I, Aly MM, Olias R, Morales PA, et al. (2012) Two closely linked tomato *HKT* coding genes are positional candidates for the major tomato QTL involved in Na^+/K^+ homeostasis. *Plant, Cell and Environment* 36: 1171-1191.

76. Shabala S, Cui TA (2008) Potassium transport and plant salt tolerance. *Physiologia Plantarum* 133: 651-669.
77. Villalta I, Bernet GP, Carbonell EA, Asins JM (2007) Comparative QTL analysis of salinity tolerance in terms of fruit yield using two *Solanum* populations of F7 lines. *Theoretical and Applied Genetics* 114: 1001-1017.
78. Venema K, Belver A, Marin-Manzano MC, Rodriguez-Rosales MP, Donaire JP (2003) A novel intracellular K^+/H^+ antiporter related to Na^+/H^+ antiporters is important for K^+ ion homeostasis in plants. *The Journal of Biological Chemistry* 278: 22453-22459.

Chapter 4

Differences in shoot Na⁺ accumulation between two tomato species are due to differences in ion affinity of HKT1;2

Pedro Almeida^{1*}, Gert-Jan de Boer² and Albertus H. de Boer¹

¹Vrije Universiteit, Faculty of Earth and Life Sciences, Department of Structural Biology Room H057, De Boelelaan 1081-1087, 1081HV Amsterdam, The Netherlands

²Enza Zaden, Oosterdijk Gebouw, P. O. Box 7, 1600 AA Enkhuizen, The Netherlands

*Corresponding author: p.m.fidalgodealmeida@vu.nl

Abstract

HKT1 has been shown to be essential in Na⁺ homeostasis in plants. In this Chapter, we report the analysis of Na⁺ accumulation in different plant organs of two tomato species with contrasting salt tolerances: *Solanum lycopersicum* and *Solanum pennellii*. Furthermore, we relate these differences in Na⁺ accumulation between the two species to the differences in HKT1;2 transport kinetics and *HKT1;2* expression. *S. lycopersicum* showed “Na⁺ excluder” behaviour, whereas *S. pennellii* showed “Na⁺ includer” behaviour. *SIHKT1;2* expression, in contrast to *SpHKT1;2* expression showed a significant effect of NaCl treatment, especially stems had a high increase in *SIHKT1;2* expression. *SIHKT1;2* promoter-*GUS* reporter gene analysis showed that *SIHKT1;2* is expressed in the vasculature surrounding the roots and shoots of transformed *Arabidopsis* plants. In this paper, we present HKT1;2 protein sequences of both tomato species and provide evidence that both *SIHKT1;2* and *SpHKT1;2* are Na⁺ transporters. Our kinetic studies showed that *SpHKT1;2*, in comparison with *SIHKT1;2*, had a lower affinity for Na⁺. This low affinity of *SpHKT1;2* correlated with higher xylem Na⁺ and higher accumulation of Na⁺ in stems and leaves of *S. pennellii*. Our findings demonstrate the importance of the understanding of transport characteristics of HKT1;2 transporters to improve the understanding of Na⁺ homeostasis in plants.

Introduction

Salinity is one of the major abiotic stresses resulting every year in substantial losses of crop yield [1,2]. One fifth of irrigated land worldwide is affected by salinity and this is predicted to become more in the future [3]. Most crop species are salt sensitive. Small amounts of NaCl (40 mM NaCl) can decrease plant growth or can be even lethal for salt sensitive plants like *Arabidopsis* or rice [3]. Deleterious effects of salinity on plant growth are caused mainly by three factors: osmotic stress, ion toxicity and nutrient deficiencies [3]. Osmotic stress occurs when the water potential of the soil is lower, due to the dissolved salts, compared to the water potential of the plant tissue, resulting in reduced water uptake of the plant. Second, ion toxicity caused by high concentrations of Na⁺ ions (>100 mM) in the cytoplasm can interfere with and disrupt enzyme functioning [3-5]. Finally, deficiencies of essential nutrients, e.g. K⁺, can occur [3]. To be able to cope with these negative effects of salinity, plants need to have tight control over the regulation of Na⁺-influx, -efflux, -allocation and -compartmentation. To achieve this, plants have a complex network of channels and transporters that are involved in ion uptake and compartmentation in their cells and tissues.

In several species, *High K⁺ Affinity Transporter (HKT)* genes have been shown to have a crucial role in Na⁺ movement throughout the plant [4,6-12]. HKT1 transporters are involved in retrieving Na⁺ from the transpiration stream [4,10-12] by mediating the influx of Na⁺ into the xylem parenchyma cells of roots [13]. Members of the HKT family can be divided in two subfamilies (HKT1 and HKT2) depending on their function as Na⁺ uniporter (HKT1) or Na⁺ and K⁺ symporter (HKT2) [14]. Although this classification in two subfamilies is widely accepted, recent studies have shown that this classification might be too simplistic [15,16]. Members of subfamily 1 have been shown to have an important role in salinity stress resistance [14]. AtHKT1;1 is localized to the plasma membrane of the xylem parenchyma cells in the shoot [10] and to the phloem tissues of both roots and shoots [8]. Therefore, it was proposed that AtHKT1;1 might be involved in Na⁺ recirculation from the shoots-to-roots via the phloem and/or Na⁺ unloading from the xylem into xylem parenchyma cells [8,10]. Using an enhancer trap system, Moller et al. [12] showed that the over-expression of *AtHKT1;1* in the mature root stele of *Arabidopsis* causes a decrease of 37 to 64 % in accumulation of Na⁺ in the shoot. This effect in the shoot is caused by augmented influx of Na⁺ into stellar root cells mediated by AtHKT1;1, which led to a reduction of root-to-shoot transfer of Na⁺ [12]. Furthermore, in rice plants the expression of *AtHKT1;1* in the root cortex was related to a lower concentration of Na⁺ in the shoots [17]. Interestingly, constitutive expression of *AtHKT1;1* in *Arabidopsis* under the cauliflower mosaic virus 35S promoter resulted in poor

growing plants accumulating high shoot Na^+ levels [12]. This might be attributed to expression of *AtHKT1;1* in cells where it is normally not expressed, leading to the disruption in the Na^+ balance between cells and tissues.

HKT genes are of crucial importance in crop plants. In hydroponic conditions, barley plants over-expressing *HvHKT2;1* show about 25 to 30% higher growth rates than wild type (WT) plants when grown in 50 or 100 mM Na^+ and 2 mM K^+ [18]. In rice, the improvement of salinity tolerance through cell specific expression of *AtHKT1;1* was also shown [17]. More recently, Munns et al. [19] published a break-through paper on the improvement of wheat salinity tolerance through the introgression of an ancestral Na^+ transporter from *Triticum monococcum* (*TmHKT1;5-A*) into the modern wheat cultivar Tamaroi. So far, all *HKT* genes shown to be involved in Na^+/K^+ homeostasis were isolated from monocotyledonous plants [9,20-22]. In addition, a study done with tomato plants suggest that this is also true for dicotyledonous plants [23]. Asins et al. [23] report that both *SlHKT1;1* and *SlHKT1;2* are located only 35 kb away from a quantitative trait loci (QTL) involved in control of shoot Na^+ accumulation. However, heterologous expression of *SlHKT1;1* and *SlHKT1;2* in yeast cells showed that only *SlHKT1;1* was able to deplete Na^+ from the growth medium [23].

Recently, several papers have shown that the correct functioning of HKT transporters relies on some specific amino acid residues and that changes in these amino acids residues can result in dramatic changes in the functioning of HKT transporters [9,24,25]. In rice, four amino acid substitutions (A140P, H184R, D332H and V395L) (alanine (A), proline (P), histidine (H), arginine (R), aspartic acid (D), valine, (V), leucine (L)) in *OsHKT1;5* were proposed by Ren et al. [9] as being responsible for the differences in functioning between rice cultivars with distinct salinity tolerance (Pokkallii and Nona Bokra-tolerant and Nipponbare sensitive). From these four amino acid substitutions Cotsaftis et al. [25] show that only amino acid substitution V395L was associated with the differences in whole plant Na^+ levels, Na^+ retention in the root, Na^+ transport rates between the rice cultivars and with salinity tolerance. Both salt tolerant rice cultivars, Nona Bokra and Pokkallii, have a V at position 395 and in comparison to the salt sensitive Nipponbare cultivar, which has a L at this same position, a lower total accumulation of Na^+ , higher retention of Na^+ in the roots and faster transport rates of Na^+ [25].

Thellungiella salsuginea is a relative of *Arabidopsis thaliana* that possesses two HKT transporters, namely *TsHKT1;1* and *TsHKT1;2*. Although, both *Thellungiella salsuginea* HKTs show a serine (S) in the first pore domain (PD), it was found that the *TsHKT1;2* is a K^+ specific transporter and that this specificity relies on the presence of two D's residues in the

second transmembrane PD of the transporter [24]. The single or double replacement of these two D by asparagine (N) residues present in AtHKT1;1, result in reduced growth of transformed CY162 yeast cells growing in the presence of Na⁺ and low K⁺ concentrations [24].

Tomato is an important model species for molecular and genetic studies and the most important vegetal crop in economic terms [26]. Tomato is considered moderately salt tolerant with a yield reduction of 50% under a moderate salinity of ~ 70 mM (8 dS/m) [27]. Among a dozen wild tomato species, *Solanum lycopersicum* is the only species being cultivated [28,29] and known to be relative salt sensitive compared to its wild relatives. *Solanum pennellii* is one of the wild relatives reported to be more salt and drought resistant [29].

In this study, we explored whether the differences in Na⁺ accumulation in the shoots of two close related tomato species are due to differences in expression levels of *HKT1;2* genes; or due to differences in the protein structures leading to altered transport properties.

Material and Methods

Plant material and growth conditions

Seeds of *Solanum lycopersicum* cultivar Arbasson and *Solanum pennellii* were obtained from Enza Zaden (Enkhuizen, the Netherlands). Before sowing, seeds were washed with 1% commercial bleach for 10 min and rinsed 3 times for 10 min with demineralised water. Seeds were germinated on wet paper and grown for 5 d before being transplanted to 2 L polyethelene pots containing half-strength Hoagland's solution. Plants were grown in a controlled growth chamber (20/15 °C; 14/10 h day/night, respectively, PAR 200 μmol.m⁻².s⁻¹) for 14 d after which salt treatments were started. Plants were randomly allocated to different salt treatments (3 replicate plants per treatment). For both *HKT1;2* gene expression and ion analysis (Na⁺ and K⁺), plants were treated with 0, 5 and 75 mM of NaCl in the root medium for 7 d. At harvest, individual plants were divided into roots, stems and leaves and plant material was either snap-frozen in liquid nitrogen and stored at -80 °C (for gene expression analysis and functional characterisation) or oven-dried for 48 h at 80 °C (for Na⁺ and K⁺ analysis). RNA extracted from plants of the 0 mM NaCl treatment served as template to produce complementary DNA and were used for functional characterization of SlHKT1;2 and SpHKT1;2 in a two electrode voltage clamping (TEVC) system using *Xenopus laevis* oocytes.

Na⁺ and K⁺ analysis

Na⁺ and K⁺ concentrations were determined in root, stem and leaf material and xylem sap using high performance liquid chromatography (HPLC). Oven dried plant material was ground into a powder with mortar and pestle. 20 mg of dried material was weighed and boiled in tubes containing 5 mL demineralised water for 1 h at 100 °C in a water bath. After boiling, samples were filtered and Na⁺ and K⁺ concentrations were determined by injecting 5 µL of sample in a Shimadzu HPLC system (10 Series, Shimadzu Corporation, Kyoto, Japan) equipped with an IC-YS50 column from Shimadzu, Shimadzu Corporation, Kyoto, Japan). HPLC calibration was made by injecting 1, 2, 5, 10 and 25 µL of standard solution containing 5 mM NaCl and 5 mM KCl. Equation derived from the standard curve was used to calculate the ion amounts measured.

Collection of xylem sap

Plants were treated with 5 or 25 mM NaCl in the root medium for 7 d because a concentration of 75 mM proved to be too high and caused plants to “bleed” very poorly preventing the collection of xylem sap. The main stem of all plants was cut 2 cm above the root-shoot line and rinsed immediately with demineralised water to wash any possible detritus present. After washing a plastic tube was attached to the shoot in order to collect the xylem sap. After 10 to 20 min the sap was transferred to a glass vial and immediately analysed for Na⁺ and K⁺ concentrations using an HPLC system as described above.

Gene expression analysis

Tomato *HKT1;2* isolation and cloning

In order to isolate the *HKT1;2* gene from tomato, the AtHKT1;1 nucleotide sequence, was blasted against the tomato genome sequence. The primers FW 5' AAGCGGCCGCATGAAGTCATCACTTTCAATTTCTTTC 3' and RV 5' GCTCTAGACGAACCTTTCATAATATT 3' were designed to isolate tomato *HKT1;2* from cDNA (see *Real-time PCR assay* for details). The full-length cDNA's were assembled and cloned into the pGEMT-Easy vector (Promega) and sequenced.

Real-time PCR assay

RNA was extracted from the same plants as used for Na⁺ and K⁺ concentration measurements. At the moment of harvest, the third leaf, a central portion of the stem and several root tips were collected and immediately frozen in liquid nitrogen, later these organs

were used for RNA extraction. RNA extraction was performed using the Innuprep Plant RNA kit (Westburg, the Netherlands). First strand cDNA was synthesized using one microgram of total RNA, random hexamers and SuperScript II Reverse Transcriptase (Invitrogen Life Technologies). First strand cDNA was used as a template for quantitative real-time PCR (qRT-PCR). Three biological samples were measured from each species in technical triplicates using a sequence detector system (7300 Real Time PCR System from Applied Biosystems). For normalization across samples within a qRT-PCR run *Slβ-actine* was used (FW 5' AAAAGTGCGAGTGTCTGTCT 3' and RV 5' TCAAAAAACAAATTGACTGG 3'). Expression of *Slβ-actine* was compared with expression of other tomato reference genes (*SICAC*, *SISAND*, *SIEF1-α* and *SITIP41*) (Almeida et al unpublished data), and was shown to be not influenced by NaCl treatment. For quantification of *Solanum lycopersicum* and *Solanum pennellii* *HKT1;2* the following primers were used: FW 5'GCATATGGGACAGTTGGATTG 3' and RV 5'GTAACATCCTTGCAATGACCA 3'. The mean normalized expression was calculated according the $2^{-\Delta\Delta C_T}$ method [30].

Generation of *Arabidopsis* transgenic lines and histochemical assays of GUS staining

A 3 Kb DNA fragment, upstream of the *ATG* start codon of the *SIHKT1;2* gene was isolated from genomic DNA and cloned into *pDONR221 P1-P2* (Invitrogen) using the primers *SIHKT1;2prom(attB1)*

GGGGACAAGTTTGTACAAAAAAGCAGGCTGTATGGGAAACTCTTTCTCGAGTC

and

SIHKT1;2prom(attB2)

GGGGACCACTTTGTACAAGAAAGCTGGGTAGCTTTAAATTAATCCCAATAAC

ATATGGTA. This construct was named *p1-2SIHKT1;2prom*. *p1-2SIHKT1;2prom* was incubated with *pKGWFS7* [31] in a LR reaction (Invitrogen) to create the *pKGWFS7+SIHKT1;2prom* construct. This construct was sequenced prior to transformation of *Arabidopsis* plants. The *pKGWFS7+SIHKT1;2prom* construct was introduced into *Agrobacterium tumefaciens* strain *GV3101pMP90*, and transformed into *Arabidopsis WT* plants. Negative control plants were transformed with *pKGWFS7* empty vector. Plant transformation was performed by flower dipping [32]. 4 weeks after transformation, seeds were harvested and surface sterilized. Surface sterilization was performed by washing seeds during 1 min with a 80 % ethanol solution supplemented with 0.1 % Tween 20, followed by a 20 min washing step with 1 % commercial bleach, and 3 washing steps with sterile MilliQ. MilliQ was then replaced by warm 0.5x MS medium supplemented with 1 % sucrose, 0.8 % agar and 50 mg/L kanamycin. Seeds were sown in round plates containing the solid MS

medium with the same composition. Seedlings showing kanamycin resistance were selected and transferred to pots containing a mix of soil and peat (1:1) and grown for 4 weeks under the same growing conditions until T2 seeds could be harvested. T2 seeds were tested for kanamycin resistance and used for GUS staining. Histochemical assays of GUS activity were conducted using samples that were stained according to the method of Jefferson et al [33]. 7 d old plantlets were incubated at 37 °C for 6h in the staining solution containing 0.5 mM X-Gluc (5-bromo-4-chloro-3-indolyl-b-D-glucuronide).

Heterologous expression in *Xenopus laevis* oocytes

Preparation of template DNA, in vitro transcription and capping of mRNA

Both tomato species *HKT1;2* cDNAs were cloned from pGEM-T Easy vector (Promega) into pGEM-HE vector [34] downstream from the T7 promoter and between 5' and 3' UTR regions of the *Xenopus beta-globin* gene. After sequencing, pGEM-HE+*SIHKT1;2* and pGEM-HE+*SpHKT1;2* were digested with *NheI* in order to make the vector linear downstream of 3'UTR region. Capped and polyadenylated cRNA was synthesized in vitro from a linearized vector using the mMACHINE T7 kit (Ambion Inc., USA).

Oocytes were obtained from Ecocyte Biosciences (Germany) and injected with either 46 ng of *SIHKT1;2* cRNA, *SpHKT1;2* cRNA (1µg/µL) or 46 nL of RNase free water. Oocytes injected with RNase free water were used as a negative control. After injection, oocytes were incubated at 16 °C in ND₉₆ solution supplemented with Na⁺-pyruvate and gentamycin for two days before electrophysiological recordings. Incubation medium was replaced every day.

Two-electrode voltage clamping of *Xenopus* oocytes

Oocytes injected with 46 ng of *Solanum lycopersicum* or *Solanum pennellii* *HKT1;2* were used 2 to 5 d after injection for recording currents induced by the expression of *HKT1;2* with the two-electrode voltage clamp technique. The voltage-clamp amplifier was an Axoclamp 2A (Axon Instruments). Voltage-pulse protocols, data acquisition, and data analyses were performed using pClamp9 (Jandel Scientific) software. Both membrane potential and current were recorded. Correction was made for voltage drop through the series resistance of the bath and the reference electrode using a voltage-recording reference in the bath close to the oocyte surface. The first electrode to be inserted in the oocyte was the voltage electrode and, after a stable membrane potential was reached, the current electrode was inserted. Electrodes were filled with a solution of 3 M KCl and microelectrodes resistances were between 0.5 and 2 MΩ. Oocytes were bathed according to the method of Uozumi et al [13]. Osmolality of all

solutions was kept between 240 and 260 mosmol/kg with D-mannitol. For I/V plots a ramp command was generated. The membrane potential was held at -60 mV and swept from -140 mV to +40 mV in 20 mV steps, 1 s duration. For selectivity curves the membrane potential was held constant at -120 mV during the duration of the experiment.

Sequence data

Sequence data from this article have been deposited at EMBL/GenBank data libraries under accession numbers: HG530659, HG530660 and HG530661.

Statistical analyses of data

Two-way ANOVA was used to assess the effect of NaCl treatment on *HKT1;2* expression and Na⁺ and K⁺ accumulation. Three-way ANOVA was used to assess the effect of NaCl treatment, organs and species on *HKT1;2* expression. Data were rank-transformed if normality or homogeneity assumptions were violated. If ANOVA was significant, a *post hoc* test (Tukey's test) was used to evaluate differences among treatments and species. All tests were performed using SPSS 17.0.

Results

Na⁺ and K⁺ measurements

The distribution of Na⁺ and K⁺ contents in leaves, stems and roots from *S. lycopersicum* and *S. pennellii* was analysed (Fig. 1). Although both *S. lycopersicum* and *S. pennellii* showed the same pattern in the increase of Na⁺ accumulation within the organ when treated with NaCl (0-75 mM), the extent of this pattern was different between these species. NaCl treatments (5 mM and 75 mM) resulted in a significant increase in Na⁺ content of leaves (Fig. 1A) and stems (Fig. 1D) of both species. However, *S. pennellii* accumulated Na⁺ to much higher levels in the stem and leaves than *S. lycopersicum* did. *S. pennellii* showed a two-fold increase in root Na⁺ accumulation when grown at 5 and 75 mM NaCl respectively, whereas *S. lycopersicum* showed an increase of almost 10-fold.

For K⁺ accumulation no significant differences were seen between the different NaCl treatments in the two species in any of the organs (Figs. 1B,E,H). The Na⁺/K⁺ ratio showed clear differences between the species: the ratios in both leaves and stems of *S. pennellii* were significantly higher than those in *S. lycopersicum* (Fig. 1C and F). In roots (Fig. 1I), *S. pennellii* showed a significantly higher Na⁺/K⁺ ratio for the 5 mM NaCl treatment, whereas at 75 mM NaCl treatment *S. lycopersicum* showed a significantly higher Na⁺/K⁺ ratio.

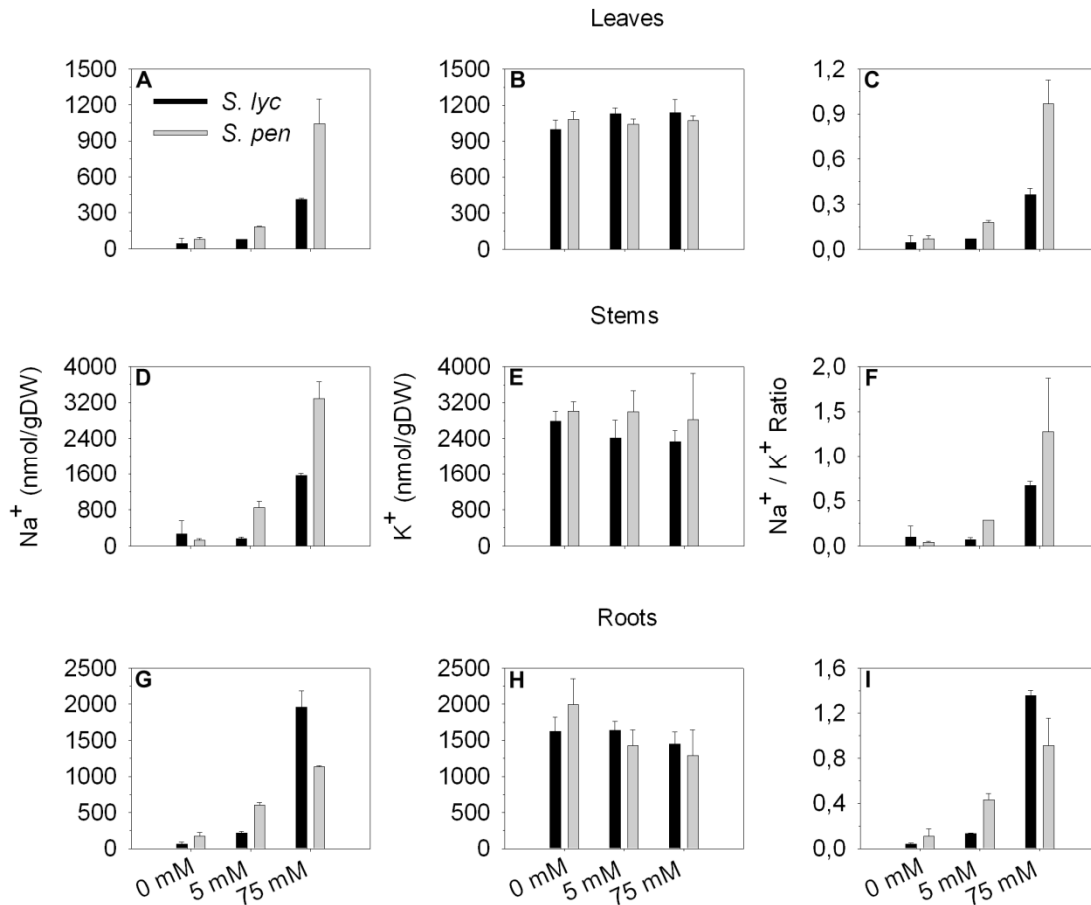

Figure 1: NaCl treatment affects the Na⁺ concentrations (A,D,G), K⁺ concentrations (B, E, H) and Na⁺/K⁺ ratio (C, F, I) of leaf (top row), stem (middle row) and root material (bottom row) of *S. lycopersicum* (black bars) and *S. pennellii* (grey bars) hydroponically grown at 0, 5, and 75 mM NaCl in the root medium for 7 d. Values are means±SE. of 3 replicates. (A, C, D) Treatment: $p<0.05$, species: $p<0.05$, treatment*species: $p<0.05$, two-way ANOVA (B) Treatment: n.s., species: n.s., treatment*species: $p<0.05$, two-way ANOVA (E, H) Treatment: n.s., species: n.s., treatment*species: n.s., two-way ANOVA (F) Treatment: $p<0.05$, species: n.s., treatment*species: n.s., two-way ANOVA (G, I) Treatment: $p<0.05$, species: n.s., treatment*species: $p<0.05$, two-way ANOVA.

Isolation of tomato *HKT1;2*

S. pennellii and *S. lycopersicum* *HKT1;2* sequences were obtained from plants grown in the absence of NaCl for 3 weeks. *HKT1;2* transcripts were detected in all organs analysed from both species. *S. pennellii* as well as *S. lycopersicum* had a *HKT1;2* gene containing an open reading frame of 1512 nucleotides encoding 504 amino acids (Fig. 2A). Both species *HKT1;2*'s show high homology: both proteins have a S in the pore of the first membrane-pore-membrane motif (MPM) and three G in the subsequent three PD. From the 13 different

amino acids between these two proteins, four of them are particularly interesting (Fig. 2B red letters). First, at position 17 *S. pennellii* has a G whereas *S. lycopersicum* has a R. This is an interesting change since G is a polar and hydrophilic amino acid, whereas R is positively charged. Second, at position 197 *S. pennellii* has an N which is a polar and hydrophilic amino acid and *S. lycopersicum* has a D which is negatively charged. Third, at position 221, only two amino acids further from the second PD, *S. pennellii* has an A and *S. lycopersicum* has a L which are both non polar amino acids. Finally, at position 344, which is the immediate amino acid after the G from the third PD, *S. pennellii* contains a glutamine (Q) which is polar and hydrophilic, whereas *S. lycopersicum* has a L which is a non-polar and hydrophobic amino acid. The hydrophobicity profiles of *S. pennellii* and *S. lycopersicum* HKT1;2 and AtHKT1;1 are very similar from the N till the C-terminus (data not shown).

A

<i>S. lycopersicum</i>	1	MKSSLSISFF	KIMMSL R VK P	FWIELGYFTT	LSLLGFLALN	YVSKPRTLPS	FRPQNLDVLF	TSVSSTTV S	MSTIEME V F S	80
<i>S. pennellii</i>	1	MKSSLSISFF	KIMMSL G VK P	FWIELGYFTT	LSLLGFLALN	YVSKPRTLPS	FRPQNLDVLF	TSVSSTTV S	MSTIEME V L S	80
<i>S. lycopersicum</i>	81	NVQLVFM T IL	MFLGGEA F T S	FL S P K L I R N K	E S K D K S F S N K	DYELGN V INV	DNKLEDV I II	NP I ED H I H D H	HDEI I K I K I S I	160
<i>S. pennellii</i>	81	NVQLVFM T IL	MFLGGEA F T S	FL S L K L I K I R N K	E N K D K S F S N K	DYELGN I INV	DNKLEDV I II	NP I ED H S H D H	HDEI I K I K I S I	160
<i>S. lycopersicum</i>	161	KLLSN V V F G Y	ILV V ILLG S S	LV S LY I I I L I P	SA K Q I L D Q K G	LN L H T F S L F T	TV S T F A N C G F	L P T N E N M M I F	K K NS G L L L L L	240
<i>S. pennellii</i>	161	KLLSN V V F G Y	ILV V ILLG S S	LV S LY I I I L I P	SA K Q I L N Q K G	LN L H T F S L F T	TV S T F A N C G F	A P T N E N M M I F	K K NS G L L L L L	240
<i>S. lycopersicum</i>	241	IP Q V L L G N T L	F A P C L R I V I M	FL W K I T R R H E	Y E Y I L K N S K	V G Y S H I F P S Y	E T I G I A I T V V	GL I V F Q F V M F	C S L E W N S E G T	320
<i>S. pennellii</i>	241	IP Q V L L G N T L	F A P C L R I V I M	FL W K I T R R H E	Y E Y I L K N S K	V G Y S H I F P S Y	E T I G I A I T V V	GL I V F Q F V M F	C S L E W N S E G T	320
<i>S. lycopersicum</i>	321	S G L S T Y E K I V	G S L F E V V N T R	H A G L S V F D L S	T F T P S I L V L F	A L M M Y L S S Y T	T F L P V D N Y E E	K S E K M K R K R G	R S L M E Y I S L S	400
<i>S. pennellii</i>	321	S G L S T Y E K I V	G S L F E V V N T R	H A G Q S V F D L S	T F T P S I L V L F	A L M M Y L S S Y T	T F L P V D N Y E E	K S E K M K R K R G	R S L M E Y I S L S	400
<i>S. lycopersicum</i>	401	Q P C C L V I F T I	L I C V E K D K M	K N D P L N F N V L	N I L F E V I S A Y	G T V G L S I G Y S	C A R Q I N P D G H	C K D V T Y G F A G	K W S N T G K F I L	480
<i>S. pennellii</i>	401	Q P C C L V I F T I	L I C V E K D K M	K N D P L N F N V L	N I L F E V I S A Y	G T V G L S I G Y S	C A R Q I N P D G H	C K D V T Y G F A G	K W S N T G K F I L	480
<i>S. lycopersicum</i>	481	I I V M F F G R S K	K Y N Q R G G K A W	500 K V L	503					
<i>S. pennellii</i>	481	I I V M F F G R L K	K Y N Q R G G K A W	500 K V L	503					

B

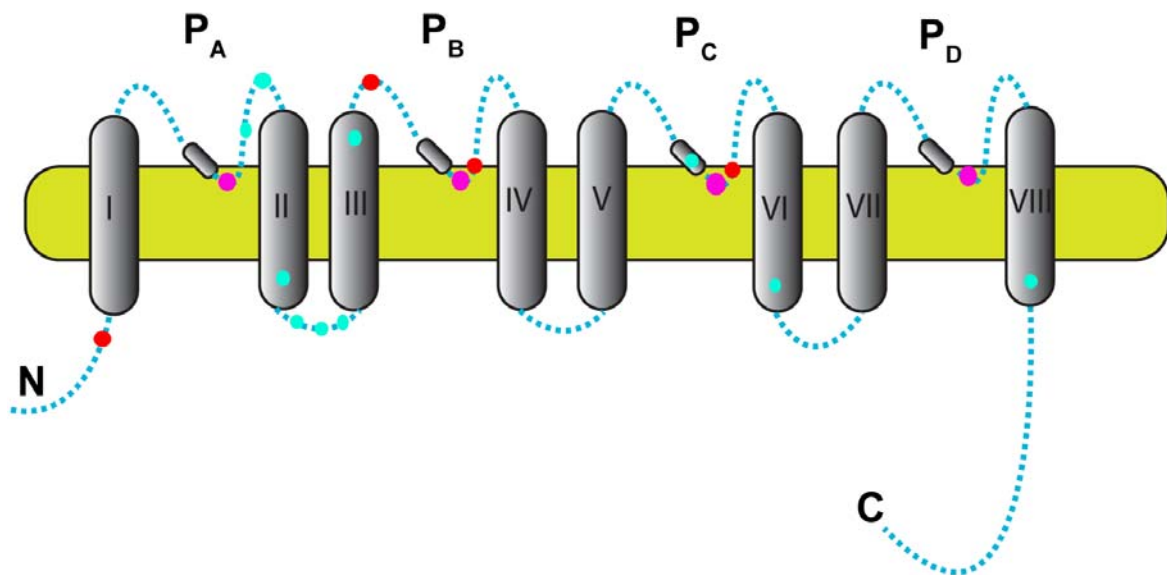

Figure 2: (A) Alignment of amino acid sequences of *HKT1;2* isolated from *S. lycopersicum* and *S. pennellii*. Amino acid sequences were deduced from nucleotide sequences of cDNA. Pore residues are shown in pink. Coloured letters point to differences between *S. lycopersicum* and *S. pennellii* amino acids. Three independent colonies per species were used for sequencing. (B) Cartoon of tomato *HKT1;2* showing where the amino acid differences between *S. lycopersicum* and *S. pennellii* are located. Red coloured letters identify amino acid differences at positions 17, 197, 221 and 344. Blue coloured letters identify amino

acid differences at positions 79, 104, 112, 127, 147, 188, 334, 368 and 489. Pink coloured letters identify the pore domains.

Expression of *HKT1;2* in planta

To understand the accumulation of Na⁺ and K⁺, *HKT1;2* transcripts were monitored organ specific (Fig. 3). *S. lycopersicum* (Fig. 3A) showed a significant effect of both NaCl treatments and organs analysed in *HKT1;2* expression. *HKT1;2* expression in organs treated with 5 mM NaCl was significantly higher than the expression in organs treated with 75 mM NaCl. Stem was the organ where the higher fold increase was observed with 3.8 and 2.2 for 5 mM and 75 mM NaCl treatment, respectively. The *HKT1;2* expression of *S. pennellii* (Fig. 3B) showed no significant effect of the NaCl treatment or organ nor an interaction effect between treatment and organ. A significant interaction effect between species and treatment was observed.

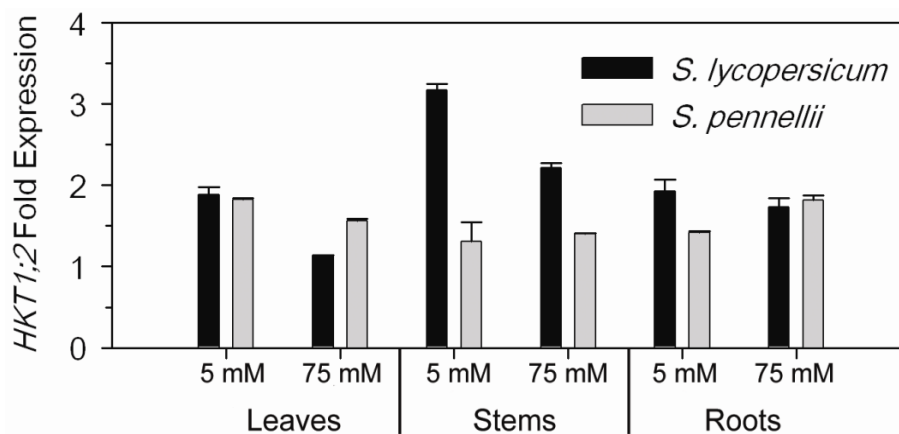

Figure 3: Organ specific expression of *HKT1;2* in *S. lycopersicum* and *S. pennellii*. Plants were treated with 5 mM NaCl (black bars) or 75 mM NaCl (grey bars) for 7 days. Values are means \pm S.E. of 3-4 replicates. *S. lycopersicum*; treatment: $p < 0.05$, organ: $p < 0.05$, two-way ANOVA. *S. pennellii*; treatment: n.s., organ: n.s., two-way ANOVA. Species*treatment: $p < 0.05$, three-way ANOVA.

Two-electrode voltage clamp

Cation selectivity

As shown above in Fig. 2, several allelic variations exist between the two tomato species in their *HKT1;2* gene. In particular the four allelic variations referred to before may be important for the transport properties of the proteins because these variations cause either changes in the

electrical properties of the amino acids, G17R and N197D, or are close to a PD, in this case the second PD A221L and third PD Q344L. To investigate the implication of the allelic differences in the tomato HKT1;2 proteins, we studied whether these allelic differences were responsible for any functional difference between the HKT1;2 transporters of *S. lycopersicum* and *S. pennellii*.

To investigate the ion selectivity properties of *S. lycopersicum* and *S. pennellii* HKT1;2 transporters, two electrode voltage clamp experiments using *Xenopus laevis* oocytes were performed (Fig. 4). Oocytes injected with 46 ng of complementary RNA from *S. lycopersicum* or *S. pennellii* HKT1;2 showed a high level of expression 2 to 3 d after injection. These oocytes were used to record HKT1;2 currents at a hyperpolarised membrane potential of -120 mV. *AtHKT1;1* injected oocytes were used as a positive control [13]. Oocytes were bathed in a solution supplemented consecutively with 100 mM monovalent chloride salts. Control water injected oocytes showed only small background currents (data not shown). Exposure of cRNA injected oocytes (*AtHKT1;1* or *SlHKT1;2* or *SpHKT1;2*) to Li^+ , Rb^+ , Cs^+ and K^+ , elicited no inward currents (Fig. 4). In contrast, when the bath solution was supplemented with Na^+ , cRNA injected oocytes from both species showed large inward currents. Oocytes injected with *SlHKT1;2* cRNA showed the highest inward currents when compared to *SpHKT1;2* or *AtHKT1;1* cRNA injected oocytes. Although HKT1;2 injected oocytes accumulate internal Na^+ through HKT1;2 [13] during the incubation in N96 solution, no positive (outward) background currents were recorded at a constant holding potential of -120 mV.

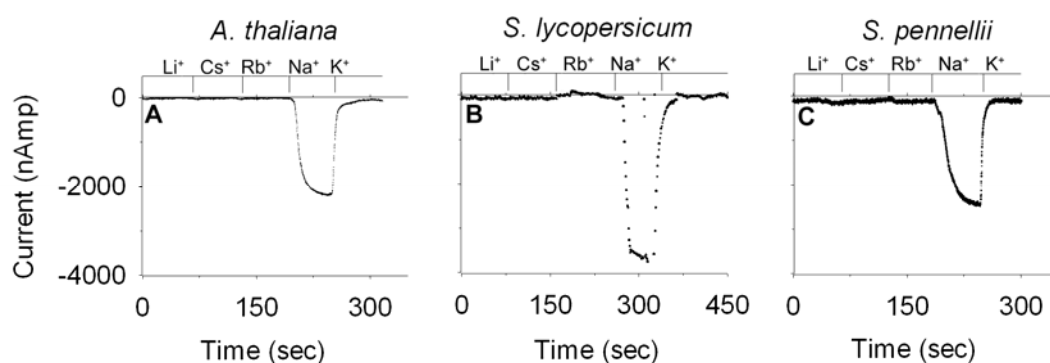

Figure 4: *AtHKT1;1*, *SlHKT1;2* and *SpHKT1;2* expressed in oocytes exhibit selectivity for Na^+ . *AtHKT1;1* (A), *SlHKT1;2* (B) and *SpHKT1;2* (C), showed only Na^+ inward currents. The bath was perfused with solutions containing 100 mM of different chloride salts, RbCl, LiCl, CsCl, KCl and NaCl, but only Na^+ produced inward currents. The membrane potential was

held at -120 mV. Each graph represents the results of at least 3 oocytes. *Arabidopsis HKT1;1* cRNA injected oocytes were used as a positive control.

Na⁺ conductance of SIHKT1;2 and SpHKT1;2

To study the effect of Na⁺ and K⁺ when applied together on SIHKT1;2 and SpHKT1;2-mediated currents (Fig. 5), oocytes were perfused with varying concentrations of K⁺ and Na⁺ according to Uozumi et al. [13]. For *AtHKT1;1*, *SIHKT1;2* and *SpHKT1;2* cRNA injected oocytes, the level of inward currents was at least 100 times larger than the current recorded in oocytes injected with water. Each of the HKT1;2 transporters studied was by far the main transport system active in the oocyte membrane. *AtHKT1;1* cRNA injected oocytes were used as a positive control [13], whereas water-injected oocytes were used as a negative control (data not shown). SIHKT1;2 or SpHKT1;2 mediated currents were measured in the presence of 0.3 mM Na⁺ with increasing K⁺ concentrations of 0.3 and 10 mM. Under these conditions the current-voltage relationship for *AtHKT1;1* cRNA injected oocytes did not change. In contrast, SIHKT1;2 or SpHKT1;2 mediated inward currents and outward currents were reduced by K⁺ although, the reversal potential of *SIHKT1;2* or *SpHKT1;2* cRNA injected oocytes was not affected. A clear blocking effect of K⁺ on the Na⁺ inward and outward currents was observed. Nevertheless, K⁺ was not transported via HKT1;2 in any of the two tomato species. *AtHKT1;1*, *SIHKT1;2* or *SpHKT1;2* mediated currents were also measured in the presence of 0.3 mM K⁺ with increasing Na⁺ concentrations of 0.3 and 10 mM. Increase of the Na⁺ concentration in the bath solution led to significant increases of inward currents as well as positive shifts in the reversal potentials of both tomato *HKT1;2* and *AtHKT1;1* injected oocytes. At hyperpolarized membrane potentials (for example -140 mV), the amplitude of inward current increased with the increase in Na⁺ concentration. Currents mediated by SIHKT1;2 or SpHKT1;2 in Na⁺-containing medium activated almost instantaneously and remained stable or slightly decreased over the range applied voltages (data not shown).

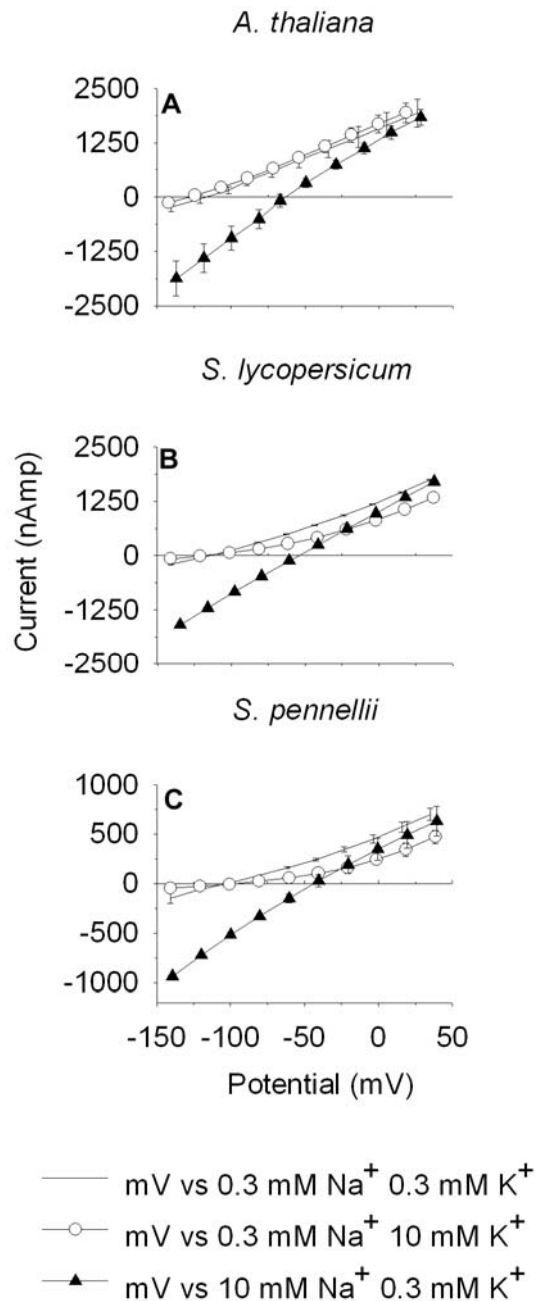

Figure 5. The Na⁺ conductance of *Arabidopsis* and tomato HKT1;2 transporters depends on Na⁺. AtHKT1;1 (A), SlHKT1;2 (B) and SpHKT1;2 (C) exhibit selectivity for Na⁺. cRNA injected oocytes were incubated for two days at 16°C in ND₉₆ solution (containing 96 mM NaCl). The membrane potential of oocytes was maintained at -60 mV and the bath solutions were prepared according to Uozumi et al. [13]. Note that both (A) and (B) show the same magnitude of the currents, whereas (C) shows much smaller currents. Data are means±SE (n=3 and represent experiments done with at least two different oocyte batches).

Affinity for Sodium

To predict an apparent affinity of AtHKT1;1, SlHKT1;2 and SpHKT1;2 for Na⁺, currents in cRNA injected oocytes were measured with different Na⁺ concentrations in the bath solution (Fig. 6). Na⁺ concentrations used in this assay were 0.3, 1, 3, 10, 30 and 100 mM. The increase of external Na⁺ concentration produced a saturable increase in inward conductance of the three HKT1 transporters studied. This increase in inward conductance was accompanied by a positive shift of the reversal potential. Regression analysis was performed for currents close to the reversal potential, and the resultant slope values were plotted. Fitting the inward conductance versus NaCl concentration in the bath solution with a Michaelis-Menten type kinetics function gave rise to the half-saturation constants ($K_{1/2}$) and maximum velocity (V_{max}) (as described in Jabnourne et al. [35]). AtHKT1;1 and SlHKT1;2 showed very similar $K_{1/2}$ and V_{max} values. The V_{max} describes the maximum velocity at which an enzyme catalyzes a reaction. The V_{max} values for AtHKT1;1 and SlHKT1;2 were 106.50 and 99.67, respectively. The $K_{1/2}$ describes a measure for the affinity of the enzyme for the substrate, and is defined as the concentration whereby the enzymatic velocity is half of the maximum enzymatic velocity (V_{max}). The $K_{1/2}$ values for AtHKT1;1 and SlHKT1;2 were 8.16 mM and 7.14 mM, respectively. The V_{max} value for SpHKT1;2 was similar to that of SlHKT1;2 (98.80), and the $K_{1/2}$ value was slightly higher (24.86 mM). These high $K_{1/2}$ values in both *S. lycopersicum* and *S. pennellii* indicate that both HKT1;2 transporters are low affinity Na⁺ transporters.

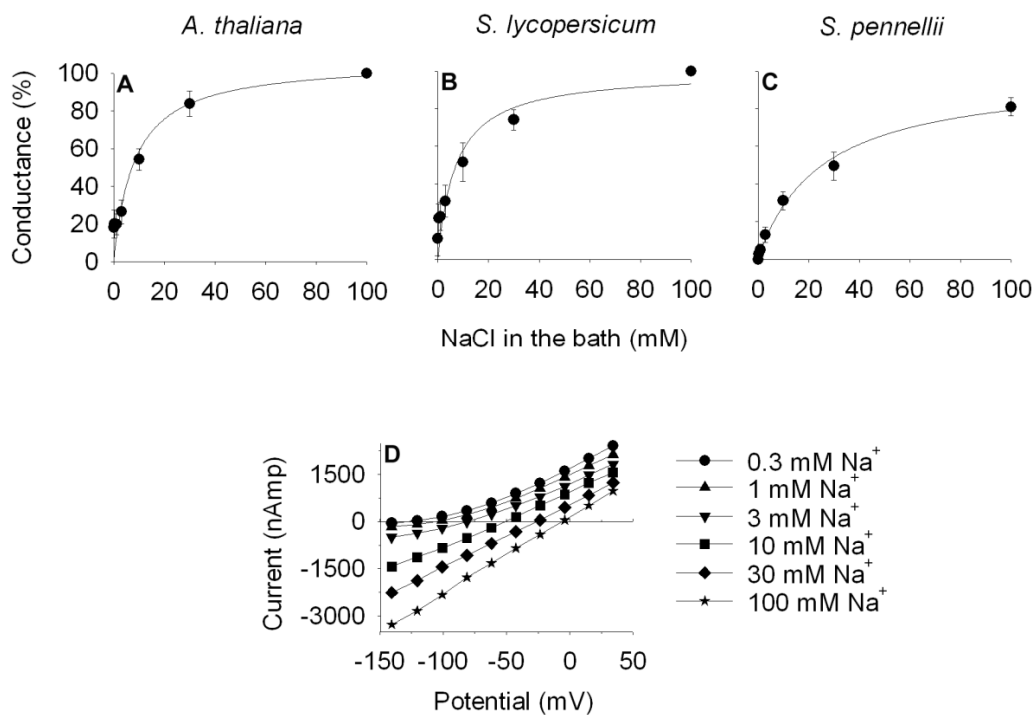

Figure 6: *Arabidopsis* and tomato HKT1;2 transporters differ in their affinity for Na⁺. AtHKT1;1 (A), SlHKT1;2 (B), SpHKT1;2 (C) inward conductance vs external Na⁺ concentration, and representative I/V plot used for the calculations of macroscopic conductances (D). Macroscopic conductances were defined as the slopes of IV plots close to reversal potentials of the transporters. Inward conductance values obtained using solutions with increasing concentrations of NaCl for each oocyte were plotted against the external NaCl concentrations and analysed according to the method of Jabnourne et al. [35]. Data are means±SE (n=7 and are representative of experiments done at least with two different oocyte batches).

GUS expression in *A. thaliana* under the *S. lycopersicum* HKT1;2 promoter

To test whether tomato HKT1;2 was expressed in the vasculature (Fig. 7), we analysed SlHKT1;2prom::*GUS* expression lines in transgenic *Arabidopsis thaliana*. We did not perform this same analysis with the SpHKT1;2 promoter because of the difficulty of to isolate a promoter fragment of the same size as the SlHKT1;2 promoter fragment. The SlHKT1;2 promoter was able to drive the *GUS* expression in the vascular tissues of both leaves (Fig. 7A) and roots (Fig. 7B) of transgenic *Arabidopsis* plants. Plants transformed with SlHKT1;2prom::*GUS* showed strongly stained cells adjacent to xylem vascular tubes (which were visible as spiral structures).

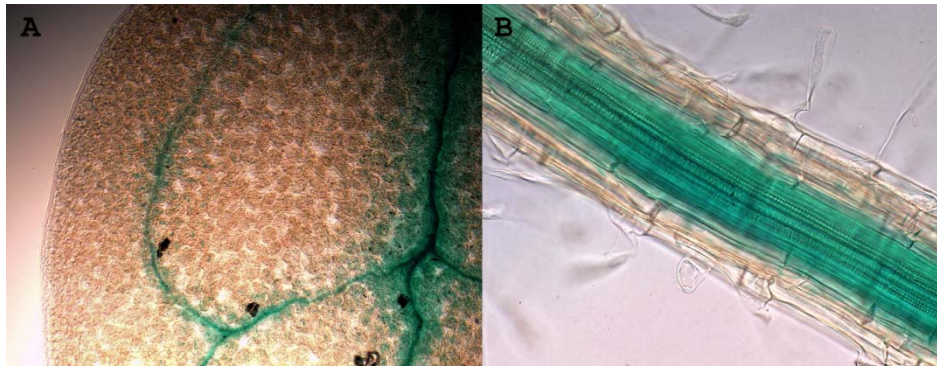

Figure 7: Detection of GUS activity in the vascular system of (A) leaves and (B) roots of *Arabidopsis thaliana*. *Arabidopsis thaliana* plants expressing the GUS gene under the control of the *SIHKT1;2* promoter were grown on 0.5 MS media containing 0.8% agar and 1% sucrose for 7 days. Strong blue GUS staining was detected in the vicinity of the xylem and phloem of both leaves and roots. Both photos were taken under a magnification of 60 times.

Xylem sap ion measurements

Due to the difference in Na^+ affinity observed between *S. lycopersicum* and *S. pennellii*, we decided to measure the Na^+ concentration of the xylem sap in plants of these two tomato species (Fig. 8). Both NaCl treatments resulted in a significantly higher Na^+ concentration in the xylem sap of *S. pennellii* compared to *S. lycopersicum* (Fig. 8A). Nevertheless, the increase in Na^+ accumulation between treatments was higher for *S. lycopersicum* with 3.1 fold increase, whereas *S. pennellii* showed only a 2.6 fold increase. The concentration of Na^+ in the xylem sap at 5 mM NaCl treatment, showed the excluding property of the roots of *S. lycopersicum*. However, at 25 mM NaCl the excluding capacity of the *S. lycopersicum* roots was overruled by the high NaCl concentration present in the medium resulting in this larger fold increase. Xylem K^+ concentrations (Fig. 8B) in *S. pennellii* were significantly higher compared to *S. lycopersicum*, although no NaCl treatment effect was observed. The Na^+/K^+ ratios were significantly higher in the xylem sap of *S. pennellii* for both NaCl treatments.

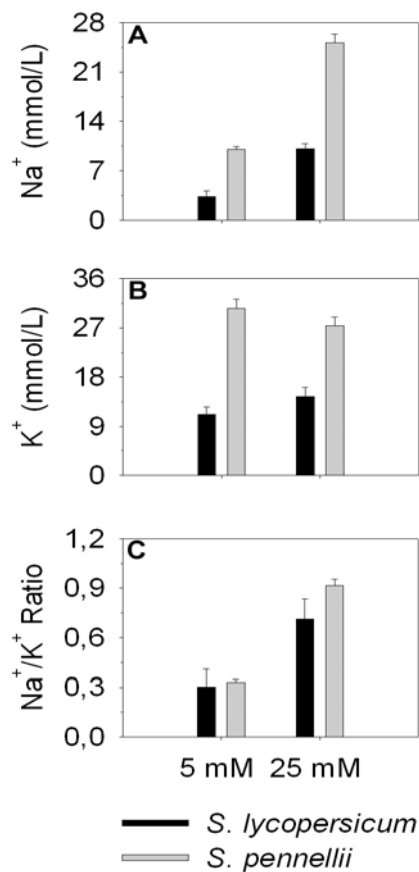

Figure 8: Na⁺ and K⁺ concentrations differ in the xylem sap of *S. lycopersicum* and *S. pennellii*. Na⁺ concentration (A), K⁺ concentration (B) and Na⁺/K⁺-ratio (C) in the xylem sap of *Solanum lycopersicum* (black bars) and *Solanum pennellii* (grey bars) treated with 5 mM NaCl or 25 mM NaCl for 7 days. Values are means±SE of 4 replicates. (A) and (C) Treatment: $p < 0.05$, species: $p < 0.05$ and treatment*species: $p < 0.05$ (B) Treatment: n.s., species: $p < 0.05$ and treatment*species: $p < 0.05$., two-way ANOVA.

Discussion

In this study, we showed that *S. lycopersicum* and *S. pennellii* have differences in Na⁺ accumulation in their roots, stems and leaves. Whereas *S. lycopersicum* showed an excluder behaviour [36–38] by excluding Na⁺ from the shoots, *S. pennellii* showed an “includer” behaviour by accumulating high concentrations of Na⁺ in the shoots [39]. The exclusion of Na⁺ from the leaves in *S. lycopersicum* is a common strategy used by non-halophytes to improve their salinity tolerance [40]. The halotolerant behaviour of *S. pennellii* is also commonly reported [41]. In contrast to the Na⁺ concentrations, both *S. lycopersicum* and *S. pennellii* were able to keep K⁺ concentrations constant in all organs throughout the duration of the NaCl treatment. However, the K⁺ concentration measured in the xylem sap was much

higher in *S. pennellii* than in *S. lycopersicum*. The maintenance of high cellular K^+ concentrations during salt stress is critical to normal plant functioning under saline conditions, since the cytosolic ratio of Na^+ and K^+ is an important determinant of Na^+ toxicity in plants [40]. Our study showed that *S. lycopersicum* was capable of keeping the Na^+/K^+ ratio in shoots lower than *S. pennellii*. Since *S. pennellii* is known to be a halotolerant species [41], this suggests that *S. pennellii* has an efficient system for Na^+ -sequestration into the vacuoles. In roots, *S. pennellii* showed a better control over maintaining a low Na^+/K^+ ratio than *S. lycopersicum*, especially when exposed to the highest salt treatment (75 mM NaCl). This agrees with the observation that salt tolerant species have better control over Na^+ -transport than salt sensitive species at relatively high Na^+ concentrations in the growth medium [42].

To be able to withstand salinity stress, it is crucial for plants to tightly regulate the amount of Na^+ present in their cells. One of the transport protein families involved in this Na^+ regulation is the HKT transport family [4,6-12,23]. The current body of literature on HKT transporters allows two conclusions [18]. First, HKT transporters are involved in Na^+ unloading from the xylem sap, they regulate the amount of Na^+ reaching the shoot [10,43]. Second, improved salinity tolerance, through genetic manipulation of HKT transport activity, correlates with a decrease in leaf Na^+ concentration [12,17]. In this study, the comparison of *HKT1;2* gene expression in different organs of *S. lycopersicum* and *S. pennellii* showed a pronounced and significant increase in *HKT1;2* expression in *S. lycopersicum* with increasing salinity, particularly in stems and roots, whereas *S. pennellii* showed a non-significant increase in *HKT1;2* expression. The higher *HKT1;2* expression in *S. lycopersicum* correlates with a lower Na^+ accumulation in the leaves. It was not possible to compare the *HKT1;1* gene expression of *S. lycopersicum* and *S. pennellii* as both plants showed extremely low *HKT1;1* expression. Furthermore, we were not able to record any currents in oocytes expressing *SIHKT1;1* or *SpHKT1;1*. Therefore, we expect the role of HKT1;1 in Na^+ transport in *S. lycopersicum* and *S. pennellii* to be trivial. Also, in a different study (Almeida et al. non published data) on the effect of salinity in Na^+ accumulation and gene expression of several genes involved in Na^+ homeostasis *in planta* we observed a correlation between leaf Na^+ accumulation and *Solanum sp HKT1;2* expression in the roots.

To characterize the HKT1;2 transport properties of *S. lycopersicum* and *S. pennellii* we expressed *SIHKT1;2* and *SpHKT1;2* in a *Xenopus* oocyte heterologous expression system. Heterologous expression showed that *SIHKT1;2* and *SpHKT1;2* were permeable to Na^+ and not to K^+ , in line with the SGGG signature. Increased K^+ concentration in the bath solution with a background of 0.3 mM Na^+ did not result in any shift in reversal potential nor in an

increase in currents for both tomato species (Fig. 5). Nevertheless, the increase in the bath K^+ concentration in the bath solution affected the Na^+ driven currents since a reduction in inward and outward currents was observed without any K^+ currents observed. A similar finding was reported for OsHKT2;1 [35] and for TmHKT1;5-A [19]. It was proposed that this inhibition is caused by the association of K^+ to the Na^+ binding region within the pore region of HKT transporters [44,45]. This inhibition has not been observed with AtHKT1;1 [13] nor OsHKT1;5 [9] in *Xenopus* oocytes, which indicates that the K^+ -sensitivity of these transporters is different from those of OsHKT2;1, TmHKT1;5-A and the tomato HKTs. The physiological role of this inhibition by K^+ has yet to be determined.

The results of the transport properties of both SIHKT1;2 and SpHKT1;2 in this study are interesting since Asins et al. reported that, when expressed in yeast cells, SIHKT1;1 but not SIHKT1;2 was able to deplete Na^+ from the growth medium [23]. The results of Asins et al. are opposed to the results presented in this study since we show clear evidence that both SIHKT1;2 and SpHKT1;2, when expressed in *Xenopus* oocytes, are able to deplete Na^+ from the bath medium.

Although the selectivity was the same and the effect of Na^+ and K^+ was very similar in both tomato species HKT1;2, the half-saturation constants were considerably different between SIHKT1;2 and SpHKT1;2. SIHKT1;2 had a K_m value of 7,14 whereas SpHKT1;2 had a K_m value of 24,86. Such a difference in K_m value allows a considerable different retrieval of Na^+ from the xylem at physiological relevant concentrations in saline environments [19]. This strategy is based on a more efficient retrieval of Na^+ from the xylem sap, preventing Na^+ from reaching the leaves in *S. lycopersicum*. HKT1;2 in *S. lycopersicum* has a high Na^+ affinity, which enables this HKT1;2 transporter to filter Na^+ present at relatively low levels from the xylem. In contrast to *S. lycopersicum*, HKT1;2 in *S. pennellii* starts to filter Na^+ out of the xylem only when the xylem Na^+ concentration is high. These differences in retrieval of Na^+ from the xylem between *S. lycopersicum* and *S. pennellii* were confirmed by the higher amount of Na^+ ions present in the xylem sap of *S. pennellii* in comparison to *S. lycopersicum* which indicates a reduced retrieval of Na^+ ions in *S. pennellii*. The pattern of GUS expression driven by the SIHKT1;2 promoter in transformed *Arabidopsis* plants also supports this role of tomato HKT1;2 *in planta*. The presence of lower and higher concentrations of Na^+ in the xylem sap, is in accordance with the “excluder” [36-38] and “includer” behaviour [39] shown by *S. lycopersicum* and *S. pennellii*, respectively. Although AtHKT1;1 has also been suggested to have a role in shoot K^+ levels via an indirect

mechanism [12], in this study no clear correlation between *HKT1;2* expression and K^+ accumulation was observed.

We suggest that the differences in Na^+ affinity of HKT1;2 in *S. lycopersicum* and *S. pennellii* are related to the amino acid differences between the two HKT protein sequences, especially those marked in red in Fig. 2. As previously shown, allelic variation between OsHKT1;5 alleles of two rice cultivars caused different functional characteristics of this transporter [9]. Between *S. lycopersicum* and *S. pennellii* this allelic variation also exist, at position 17 and position 197 *S. pennellii* has electrically charged amino acids whereas *S. lycopersicum* does not have electrically charged amino acids. These amino acids might be important, since electrically charged amino acids are known to play a role in the binding of substrate to the pore of these transporters. Although it is still not clear whether charged amino acids enhance or decrease binding of substrate to the pore of these transporters. Furthermore, at positions 221 and 344 *S. pennellii* has two different amino acids in comparison to *S. lycopersicum*. Although, these amino acids are not electrically charged, they are situated very close to the second and third PD of the HKT1;2 transporter. Because of the proximity to the pore, it is possible that these differences play a role in the affinity of the transporter. Several studies done with plant proteins showed that differences of just two amino acids between protein sequences were sufficient to dramatically change the kinetic properties of several proteins [46-52]. For example, in the plant high-affinity nitrate transporter CHL1, the replacement of a single threonine (T) amino acid T101 by either D or A, changed greatly the V_{max} and K_m values of the mutated CHL1 transporter in comparison to the wild type [50]. Nevertheless, to confirm this hypothesis it would be necessary to perform targeted mutagenesis and comparisons of both wild type and mutated versions of the HKT1;2 transporters from *S. lycopersicum* and *S. pennellii*.

In conclusion, this paper reports the differences in Na^+ accumulation in different organs between *S. lycopersicum* and *S. pennellii* and relates this to the differences in HKT1;2 K_m and *HKT1;2* expression. The lower HKT1;2 K_m combined with the higher *HKT1;2* expression in roots and stems in *S. lycopersicum* could explain the higher Na^+ accumulation in the roots and lower Na^+ accumulation in the shoots of *S. lycopersicum* compared to *S. pennellii*. We suggest that the lower K_m of SpHKT1;2 might be due to four different amino acids in the *S. pennellii* HKT1;2 protein sequence.

References

1. Zhu JK (2001) Plant salt tolerance. *Trends in Plant Science* 6: 66-71.
2. Horie T, Schroeder JI (2004) Sodium transporters in plants. Diverse genes and physiological functions. *Plant Physiology* 136: 2457-2462.
3. Munns R, Tester M (2008) Mechanisms of salinity tolerance. *Annual Review of Plant Biology* 59: 651-681.
4. Jha D, Shirley N, Tester M, Roy SJ (2010) Variation in salinity tolerance and shoot sodium accumulation in *Arabidopsis* ecotypes linked to differences in the natural expression levels of transporters involved in sodium transport. *Plant Cell and Environment* 33: 793-804.
5. Tester M, Davenport R (2003) Na⁺ tolerance and Na⁺ transport in higher plants. *Annals of Botany* 91: 503-527.
6. Rus A, Yokoi S, Sharkhuu A, Reddy M, Lee BH, et al. (2001) AtHKT1 is a salt tolerance determinant that controls Na⁺ entry into plant roots. *Proceedings of the National Academy of Sciences of the United States of America* 98: 14150-14155.
7. Maser P, Eckelman B, Vaidyanathan R, Horie T, Fairbairn DJ, et al. (2002) Altered shoot/root Na⁺ distribution and bifurcating salt sensitivity in *Arabidopsis* by genetic disruption of the Na⁺ transporter AtHKT1. *FEBS Letters* 531: 157-161.
8. Berthomieu P, Conejero G, Nublat A, Brackenbury WJ, Lambert C, et al. (2003) Functional analysis of AtHKT1 in *Arabidopsis* shows that Na⁺ recirculation by the phloem is crucial for salt tolerance. *EMBO Journal* 22: 2004-2014.
9. Ren ZH, Gao JP, Li LG, Cai XL, Huang W, et al. (2005) A rice quantitative trait locus for salt tolerance encodes a sodium transporter. *Nature Genetics* 37: 1141-1146.
10. Sunarpi, Horie T, Motoda J, Kubo M, Yang H, et al. (2005) Enhanced salt tolerance mediated by AtHKT1 transporter-induced Na⁺ unloading from xylem vessels to xylem parenchyma cells. *Plant Journal* 44: 928-938.
11. Davenport RJ, Munoz-Mayor A, Jha D, Essah PA, Rus A, et al. (2007) The Na⁺ transporter AtHKT1;1 controls retrieval of Na⁺ from the xylem in *Arabidopsis*. *Plant Cell and Environment* 30: 497-507.
12. Moller IS, Gilliam M, Jha D, Mayo GM, Roy SJ, et al. (2009) Shoot Na⁺ exclusion and increased salinity tolerance engineered by cell type-specific alteration of Na⁺ transport in *Arabidopsis*. *Plant Cell* 21: 2163-2178.
13. Uozumi N, Kim EJ, Rubio F, Yamaguchi T, Muto S, et al. (2000) The *Arabidopsis* HKT1 gene homolog mediates inward Na⁺ currents in *Xenopus laevis* oocytes and Na⁺ uptake in *Saccharomyces cerevisiae*. *Plant Physiology* 122: 1249-1259.
14. Platten JD, Cotsaftis O, Berthomieu P, Bohnert H, Davenport RJ, et al. (2006) Nomenclature for HKT transporters, key determinants of plant salinity tolerance. *Trends in Plant Science* 11: 372-374.
15. Ali Z, Park HC, Ali A, Oh DH, Aman R, et al. (2011) TsHKT1;2 a HKT1 homolog from the extremophile *Arabidopsis*-relative *Thellungiella salsuginea*, shows K⁺ specificity in the presence of NaCl. *Plant Physiology*.
16. Lan WZ, Wang W, Wang SM, Li LG, Buchanan BB, et al. (2010) A rice high-affinity potassium transporter (HKT) conceals a calcium-permeable cation channel. *Proceedings of the National Academy of Sciences of the United States of America* 107: 7089-7094.
17. Plett D, Safwat G, Gilliam M, Moller IS, Roy S, et al. (2010) Improved salinity tolerance of rice through cell type-specific expression of *AtHKT1;1*. *PloS One* 5.
18. Mian A, Oomen RJ, Isayenkow S, Sentenac H, Maathuis FJ, et al. (2011) Overexpression of a Na⁺ and K⁺-permeable HKT transporter in barley improves salt tolerance. *Plant Journal* 68: 468-479.
19. Munns R., James RA, Xu B, Athman A, Conn JS, et al. (2012) Wheat grain yield on saline soils is improved by an ancestral Na⁺ transporter gene. *Nature Biotechnology* 30: 360-364.
20. James RA, Davenport RJ, RM (2006) Physiological characterisation of two genes for Na⁺ exclusion in durum wheat: *Nax1* and *Nax2*. *Plant Physiology* 142: 1537-1547.

21. Huang SB, Spielmeier W, Lagudah ES, James RA, Platten JD, et al. (2006) A sodium transporter (HKT7) is a candidate for *Nax1*, a gene for salt tolerance in durum wheat. *Plant Physiology* 142: 1718-1727.
22. Byrt CS, Platten JD, Spielmeier W, James RA, Lagudah ES, et al. (2007) HKT1;5-like cation transporters linked to Na⁺ exclusion loci in wheat, *Nax2* and *Knal*. *Plant Physiology* 143: 1918-1928.
23. Asins JM, Villalta I, Aly MM, Olias R, Morales PA, et al. (2013) Two closely linked tomato *HKT* coding genes are positional candidates for the major tomato QTL involved in Na⁺/K⁺ homeostasis. *Plant, Cell and Environment* 36: 1171-1191.
24. Ali Z, Park HC, Ali A, Oh D-H, Aman R, et al. (2012) TsHKT1;2, a HKT1 homolog from the extremophile *Arabidopsis* relative *Thellungiella salsuginea*, shows K⁺ specificity in the presence of NaCl. *Plant Physiology* 158: 1463-1474.
25. Cotsaftis O, Plett D, Shirley N, Tester M, Hrmova M (2012) A two-staged model of Na⁺ exclusion in rice explained by 3D modeling of HKT transporters and alternative splicing. *PLoS One* 7: e39865.
26. Nuez F, Prohes J, Balnac JM (2004) Relationships, origin, and diversity of Galapagos tomatoes: implication for the conservation of natural populations. *American Journal of Botany* 91: 86-99.
27. Subbarao GV, Johansenand C (1999) Strategies and scope for improving salinity tolerance in crop plants. In: Pessaraki M, editor. *Handbook of Plant and Crop Stress*, Second Edition: CRC Press. pp. 1069-1087.
28. Spooner DM, Peralta IE, Knapp S (2005) Comparison of AFLPs with other markers for phylogenetic inference in wild tomatoes [*Solanum L.* section *Lycopersicon* (Mill.) Wettst.]. *Taxon* 54: 43-61.
29. Chetelat RT, Pertuze RA, Faundez L, Graham EB, Jones CM (2009) Distribution, ecology and reproductive biology of wild tomatoes and related nightshades from the Atacama Desert region of northern Chile. *Euphytica* 167: 77-93.
30. Livak KJ, Schmittgen TD (2001) Analysis of relative gene expression data using real-time quantitative PCR and the 2-delta-deltaCT method. *Methods* 25: 402-408.
31. Karimi M, Inze D, Depicker A (2002) GATEWAY vectors for *Agrobacterium*-mediated plant transformation. *Trends in Plant Science* 7: 193-195.
32. Clough SJ, Bent AF (1998) Floral dip: a simplified method for *Agrobacterium*-mediated transformation of *Arabidopsis thaliana*. *Plant Journal* 16: 735-743.
33. Jefferson RA, Kavanagh TA, Bevan MW (1987) *GUS* fusion: *beta-glucuronidase* as a sensitive and versatile gene fusion marker in higher plants. *EMBO Journal* 20: 3901-3907.
34. Liman RE, Tytgat J, Hess P (1992) Subunit stoichiometry of a mammalian K⁺ channel determined by construction of multimeric cDNAs. *Neuron* 9: 861-871.
35. Jabnune M, Espeout S, Mieulet D, Fizames C, Verdeil JL, et al. (2009) Diversity in expression patterns and functional properties in the rice HKT transporter family. *Plant Physiology* 150: 1955-1971.
36. Perez-Alfocea F, Estan MT, Santa CA, Bolarin MC (1993) Effects of salinity on nitrate, total nitrogen, soluble protein and free amino acid levels in tomato plants. *Journal of Horticultural Science* 68: 1021-1027.
37. Martinez-Rodriguez MM, Estan MT, Moyano E, Garcia-Abellan JO, Flores FB, et al. (2008) The effectiveness of grafting to improve salt tolerance in tomato when an “excluder” genotype is used as scion. *Environmental and Experimental Botany* 63: 392-401.
38. Foolad MR (2004) Recent advances of salt tolerance in tomato. *Plant Cell Tissue and Organ Culture* 76: 101-119.
39. Bolarin MC, Gernandez FG, Cruz V, Cuartero J (1991) Salinity tolerance in four wild tomato species using vegetative yield-salinity response curves. *Journal American Society Horticultural Science* 116: 286-290.
40. Fairbairn DJ, Liu WH, Schachtman DP, Gomez-Gallego S, Day SR, et al. (2000) Characterisation of two distinct HKT1-like potassium transporters from *Eucalyptus camaldulensis*. *Plant Molecular Biology* 43: 515-525.

41. Saed A, Shahid MQ, Anjum SA, Khan AA, Shakeel A, et al. (2011) Genetic analysis of NaCl tolerance in tomato. *Genetics and Molecular Research* 10: 1754-1776.
42. Volkov V, Amtmann A (2006) *Thellungiella halophila*, a salt-tolerant relative of *Arabidopsis thaliana*, has specific root ion-channel features supporting K^+/Na^+ homeostasis under salinity stress. *The Plant Journal* 48: 342-353.
43. Rus A, Lee BH, Munoz-Mayor A, Sharkhuu A, Miura K, et al. (2004) AtHKT1 facilitates Na^+ homeostasis and K^+ nutrition in planta. *Plant Physiology* 136: 2500-2511.
44. Rubio F, Gassmann W, Schroeder JI (1995) Sodium-driven potassium uptake by the plant potassium transporter HKT1 and mutations conferring salt tolerance. *Science* 270: 1660-1663.
45. Gassmann W, Rubio F, Schroeder JI (1996) Alkali cation selectivity of the wheat root high-affinity potassium transporter HKT1. *Plant Journal* 10: 869-882.
46. Maryon EB, Molloy SA, Ivy K, Yu H, Kaplan JH (2013) Rate and regulation of copper transport by human copper transporter 1 (hCTR1). *The Journal of Biological Chemistry* 288: 18035-18046.
47. Ray SP, Duval N, Wilkinson TG, Shaheen SE, Ghosh K, et al. (2013) Inherent properties of adenylosuccinate lyase could explain S-Ado/SAICAR ratio due to homozygous R426H and R303C mutations. *Biochimica et Biophysica Acta* 1834: 1545-1553.
48. Richards R, Dempski RE (2012) Re-introduction of transmembrane serine residues reduce the minimum pore diameter of Channel rhodopsin-2. *PLoS One* 7: e50018.
49. Brown TR, Drummond ML, Barelier S, Crutchfield AS, Dinescu A, et al. (2011) Aspartate 458 of human glutathione synthetase is important for cooperativity and active site structure. *Biochemical and Biophysical Research Communications* 411: 536-542.
50. Ho CH, Lin HC, Tsay YF (2009) CHL1 functions as a nitrate sensor in plants. *Cell* 138: 1184-1194.
51. Bagchi R, Salehin M, Adeyemo OS, Salazar C, Shulaev V, et al. (2012) Functional assessment of the *Medicago truncatula* NIP/LATD protein demonstrates that it is a high-affinity nitrate transporter. *Plant Physiology* 160: 906-916.
52. Salehin M, Huang YS, Bagchi R, Sherrier DJ, Dickstein R (2013) Allelic differences in *Medicago truncatula* NIP/LATD mutants correlate with their encoded proteins' transport activities in planta. *Plant Signaling and Behaviour* 8: e22813.

Chapter 5

Assessment of SIHKT1;2 natural variation and characterization of mutated versions of SIHKT1;2 expressed in *Xenopus laevis* oocytes

Pedro Almeida^{1*}, Gert-Jan de Boer² and Albertus H. de Boer¹

¹Vrije Universiteit Amsterdam, Faculty Earth and Life Sciences, Department of Structural Biology, NL-1081 HV Amsterdam, the Netherlands

²ENZA Zaden, R&D Haling 1/E, 1602DB Enkhuizen

*Corresponding author: p.m.fidalgodealmeida@vu.nl

Abstract

Several studies have shown that in plants single nucleotide polymorphisms (SNPs) in genes involved in Na⁺ and K⁺ homeostasis can have a dramatic effect on the salinity tolerance. For HKT transporters SNPs within the *HKT* coding sequence have been reported that are important for the functioning of these transporters in several plant species. Studies of natural variation and studies of multiple site-directed mutations of HKT transporters are crucial to understand how these transporters function. In this study we analysed the natural variation present in several regions of the *HKT1;2* coding sequence of 93 different tomato accessions. Sequence results showed that all regions tested were conserved among all accessions analysed and SNPs affecting critical amino acids were not found.

Analysis of mutations introduced in the *SIHKT1;2* gene showed that the replacement of S70 by a G allowed SIHKT2;1 to transport K⁺, but at the same time resulted in a large reduction in both Na⁺ and K⁺ mediated currents. The stacking of mutations in positively charged amino acids in the M2_D domain of SIHKT2;1 caused a reduction of Na⁺ mediated currents ultimately leading to a complete loss-of-function. A double mutant of interest is the *SIHKT2;1-S70G-K477Q* mutant that we generated: this protein passes both Na⁺ and K⁺ ions at a reasonable rate. The *in vivo* activity of this protein will be tested by complementation of *athkt1* mutant plants. A comparison of the transport characteristics of the wild-type SIHKT1;2 and AtHKT1;1 proteins in *Xenopus laevis* oocytes showed that Na⁺-transport by the tomato

SIHKT1;2 protein is allosterically inhibited by the presence of K^+ at the outside of the membrane, whereas AtHKT1 mediated Na^+ -transport is K^+ -insensitive. This K^+ -sensitivity of SIHKT1;2 may be physiologically relevant for controlling Na^+/K^+ homeostasis of the xylem sap flowing from the roots to the shoot.

Introduction

During the growth season crop plants are often exposed to abiotic stresses, including flooding, drought, high/low temperatures and salinity [1]. Salinity stress imposes an increasing and major problem affecting crop productivity worldwide [2]. The discovery of genetic polymorphisms underlying the adaptation to salinity stress is important for a better understanding of the functions of genes involved in the adaptation mechanisms. This information will provide tools for the development of crops more tolerant to this stress. The diversity of phenotypes within the same genus across environmental gradients of stress can indicate the suitability for selection, and the study of the genotypes responsible for those phenotypes might lead to the discovery of genetic polymorphisms responsible for these adaptive responses [3].

In rice a quantitative trait locus analysis (QTL) identified a very interesting locus for salt stress adaptation [4]. This QTL was narrowed down to a gene encoding an HKT transporter - OsHKT1;5 [4]. Analysis of OsHKT1;5 in two rice cultivars differing in their salinity tolerance showed that both the cellular location and expression patterns of OsHKT1;5 were identical. Nevertheless, differences in the coding region producing 4 amino acid substitutions (A140P, H184R, D332H, V395L) (A - alanine; P – proline; H – histidine; R – arginine; D – aspartic acid; V – valine; L – leucine), between Nona Bokra and Koshihikari cultivars were observed and linked to the functional variation of these two alleles and, consequently, to the tolerant and sensitive behaviour of Nona Bokra and Koshihikari, respectively [4]. In a recent paper, Cotsaftis et al. [5] analysed the importance of these amino acid substitutions and they concluded that V395L could directly affect the Na^+ transport rates, due to its strategic location close to G391 and the entrance of the pore. The other three substitutions are located in the cytoplasm-exposed loops. This makes interference with Na^+ uptake from the apoplast unlikely, but they may be involved in cytoplasmic regulation [5].

A comparison of the *Arabidopsis* accessions Tsu and Ts [3,6] showed that in *AtHKT1;1*, the presence of either a T or C at position Chr4:6392276, coding for a phenylalanine (F) (TTC) or a serine (S) (TCC), respectively, correlated with high or low leaf Na^+ concentrations, respectively [3,6]. Moreover, these two accessions were shown to have a deletion in a tandem

repeat located upstream of the *AtHKT1;1* gene in the promoter region [3]. This deletion is responsible for the weak *AtHKT1;1* allele which is related to high leaf Na^+ concentration [7] and to the salinity tolerance of Ts and Tsu [6]. In a study with *Thellungiella salsuginea* *TsHKT1;2*, it was shown [8] that two aspartic acid (D) residues (D207 and D238) were responsible for the K^+ selectivity of this transporter [8]. *TsHKT1;2* differs from *AtHKT1;1* and *TsHKT1;1* as the later two transporters select for Na^+ and have asparagine (N) residues where *TsHKT1;2* has D residues [8]. When these D residues were replaced (single or double) by N residues the transporter was no more able to transport K^+ [8].

Besides natural variation, studies of single [9,10] or multiple [11] site-directed mutations of HKT transporters [9-11] are also crucial for the understanding of how these transporters function. The replacement of the S in the first pore domain (PD) by a glycine (G) of *AtHKT1;1* changed *AtHKT1;1* from a Na^+ uniporter to a Na^+/K^+ symporter [9]. By replacing a single [10] or several [11] positively charged amino acids in the M2_D trans-membrane segment of the *TaHKT2;1* protein from wheat, the transport activity was also modified. From this it was concluded that the distribution of positively charged amino acids in the M2_D helix is important for the proper functioning of this transporter [11]. The authors point out that some ion transporter models postulate a barrier to prevent the diffusion of ions down their electrochemical gradient, and the presence of an uncoupled positively charged amino acid might pose a barrier to the transport of ions; some ion transporter models require a barrier to prevent the diffusion of ions [11].

Until recently, high-resolution DNA melting technology (HRM) was used mainly to identify mutations responsible for human diseases [12]. Since it has become a low-cost and straightforward method, which is able to detect the presence of SNPs in small PCR amplicons, it is now used in plant biology as well [13]. The HRM technique measures the temperature necessary to separate DNA double strands and has enough resolution power to detect variations of a single base difference between different samples. HRM needs unlabelled probes, usually between 20 to 35 bp in length, blocked at their 3' end to prevent extension [14]. Asymmetric PCR is also required to produce a surplus of the strand complementary to the probe. In this way both DNA strands (probe + DNA amplicon) can anneal. After annealing, DNA duplexes are submitted to increasing temperatures until denaturation occurs. The presence of a single base difference in this DNA duplex influences the stability leading to a reduction in the melting temperature (T_m) and consequently in the shape of the melting curve [15].

In this study, regions of the *HKT1;2* gene from different tomato accessions were tested with the HRM technique. *Solanum lycopersicum HKT1;2* coding sequence was used as the reference sequence and profiles in other accessions differing in their melting peaks were sequenced and their SNPs identified. All DNA regions of interest tested proved to be conserved in all accessions studied. This led to the decision to induce mutations affecting these regions and test their effects on ion transport by heterologous expression of mutated *SIHKT1;2* genes in *Xenopus laevis* oocytes. We substituted the S70 residue of the first PD of *Solanum lycopersicum* by a G and analysed the effect of this substitution on the selectivity of the transporter. Furthermore, we combined constructs with an S and constructs with a G in the first PD with added substitutions of positively charged amino acids in the M2_D of SIHKT1;2. We also analysed the effect of these mutations on the selectivity and total currents of the transporter. Replacement of the S by a G in SIHKT1;2 enabled the transport of both Na⁺ and K⁺ in all constructs tested. However, this mutation also resulted in a decrease in total current and symport of both Na⁺ and K⁺. The replacement of positively charged amino acids in the M2_D of SIHKT1;2 resulted in a decrease in the total currents measured in *Xenopus oocytes*. Stacking of mutations of positively charged amino acids in the M2_D resulted in an inactive SIHKT1;2 transporter.

Material and methods

Plant material

Genomic DNA used in this experiment was extracted from the same plants as used in Chapter 2 (see Chapter 2 for growing conditions). For the extraction of genomic DNA approximately 25 mg of dried material of each accession was weighed and inserted in each well of a 96 deep well plate. For the extraction of DNA a Nucleospin 96 Plant II kit (Macherey-Nagel, Germany) was used and the manufacturer's protocol was followed. The quality of the gDNA was checked on a 1.5% agarose gel. The concentration of the gDNA was calculated using the Quanti-iT™ PicoGREEN dsDNA assay kit (Invitrogen). gDNA was diluted in TE buffer pH 8.0 (10 mM Tris and 1 mM EDTA) and kept at +4°C.

Analysis of natural variation

20 ng of gDNA per sample was used to study natural variation in tomato *HKT1;2* nucleotides of different cultivars. Per reaction, 3.21 µl of MilliQ, 0.05 µl of FW primer (10 µmol/µl) and 0.25 µl RV primer (10 µmol/µl), 0.04 µl of Taq polymerase (5U/µl), 0.25 µl LC Green (BioFire, Salt Lake City, USA), 0.20 µl dNTP (5 mM) and 1 µl 5x PCR buffer supplemented

with 12.5 mM MgCl₂, were mixed. The amplification reaction started with a denaturation step of 95 °C for 10 min and continued with 14 cycles of 95 °C for 15 sec and 60 °C for 4 min. Samples were cooled to room temperature and a first melting curve analysis was performed to assess the quality of the amplification. Samples were again cooled down to room temperature and 2 µl (10 pmol/µl) of the specific probe was added. Samples were heated to 96 °C for 3 min and cooled down to room temperature before analysing the melting curve of the specific probes. *SIHKT1;2* coding sequence isolated from *S. lycopersicum* Arbasson F1 was used as the reference. Amplicons that showed a melting curve different from the reference melting curve were selected, amplified and sequenced. Sequencing of the amplicons was performed at Macrogen Europe Laboratories, Amsterdam, the Netherlands.

Primer and probe design

Primers and probes (Table 1) were designed to have a T_m of between 60 and 67 °C with DNASIS MAX v3.0 software. Pairs of primers were designed to flank the SNPs being studied. The size of amplicons was kept smaller than 150 nucleotides. Unlabelled probes were blocked at its 3' end to prevent extension in PCR reactions and designed to anneal to the region containing the SNP of interest. The reactions were performed in 384-well plates. Each reaction well contained 20 ng of template gDNA, 0.05 µl of limiting primer (10 pmol/µl), 0.25 µl of excess primer (10 pmol/µl), 0.2 µl of dNTP (5 mM), 0.04 µl of PAL polymerase (5U/µl), 0.25 µl LC Green (Idaho Technology, Salt Lake City, USA), 1 µl of PAL buffer supplemented with 12.5 mM MgCl₂ and 3.21 µl of MilliQ. PCR reactions were overlaid with 10 µl mineral oil to avoid losses of the mixtures by evaporation ensuring the uniformity of melting curves. The reaction conditions were as follows: 94 °C for 2 min, followed by 49 cycles of 15 sec at 92 °C; 30 sec at 60 °C and 15 sec at 72 °C. The last step was 2 min at 72 °C.

Table 1: List of primers and probes used to study the presence or absence of SNPs in *Solanum* sp. gDNA sequence regions where amino acids with important roles in the functioning of the transporter were identified in other plant species.

Nucleotide tested	Primer name	Primer sequence (5' to 3')
N217	SIHKT1;2 F14	GCCAAACAAATCCTTGACCA
	SIHKT1;2 R14	TCATCATGTTTTTCATTTGTAGG
	SIHKT1;2 P14a	CACAGTATCAACTTTTGCAAATTGTGGTTTTTA
	SIHKT1;2 P14b	CACCACAGTATCAACTTTTGCAAATTGTGGTTTTTA
N248	SIHKT1;2 F15	TGATTTTCAAGAAAAATTCAGGTC
	SIHKT1;2 R15	GATGCGTAAACAAGGAGCAAA
	SIHKT1;2 P15a	CCTCAAGTCCTTCTAGGGAACACTTTGT TTC
	SIHKT1;2 P15b	CTTATCCCTCAAGTCCTTCTAGGGAACACTTA
F92 (C to T)	SIHKT1;2 F20	TTGAAATGGAAGTTTTCTCAAATG
	SIHKT1;2 R20	AAGGCTAAGAAAAGAGGTAAAAGC
	SIHKT1;2 P20	ACCATATTGATGTTTCTTGGTGGGGAAGG
K477	SIHKT1;2 F21	ATGGATTTGCTGGAAAATGG
	SIHKT1;2 R21	TTCCAAGCTTTCCCTCCTC
	SIHKT1;2 P21	TAATACAGGAAAGTTCATTTTGATAATTGTCATGTA
R488, K490, K491	SIHKT1;2 P22	TTTTTGGAAGGTTGAAGAAGTATAATCAAAGAGC
	SIHKT1;2 R23	AAGTAGCCCATAGTTGGGAAG
R495, K498	SIHKT1;2 P23	GTATAATCAAAGAGGAGGGAAAGCTTGAAT

Melting curve analysis and gDNA sequencing

The quality of PCR products was assessed by heating the PCR products to 95 °C at 0.3 °C/sec before the probe was added. PCR products showing similar melting curves were considered of good quality whereas outliers were discarded. The mix of PCR products+probe was heated to 94 °C for 2 min and then cooled down to room temperature to allow hetero-duplex formation. Then the mix of PCR products+probe was re-heated to 95 °C at 0.3 °C/sec. Data was acquired between 50 and 95 °C. Data acquisition was made with a Light Scanner HR384 (Idaho Technology Inc. Salt Lake City, USA). HRM curve analysis was performed using the “Unlabeled Probes” module in the “genotyping” mode of the software. This mode involves negative filter, normalization and grouping. Samples showing natural variation within the tested region were sequenced. 20 ng of genomic DNA was used to amplify the *HKT1;2* gene. Because the *HKT1;2* gene has two introns within the coding region it was amplified in two different fragments.

Plasmid construction.

Site-directed mutagenesis of *SIHKT1;2* was conducted using overlap extension PCR. All primers used to make mutated *HKT1* genes are listed in Table 2. *pGEM-HE+SIHKT1;2* and *pGEM-HE+AtHKT1;1* were used as template and the corresponding mutated gene cloned into

the BamHI and XbaI restriction sites and SphI and XbaI restriction sites of an empty pGEM-HE vector for tomato and *Arabidopsis HKT1*, respectively. All PCR derived DNA fragments were confirmed by sequencing.

Table 2: Primers used to mutate *SIHKT1;2* and *AtHKT1;1*

Primer name	Primer sequence (5' to 3')
SIHKT1;2-S70G Fw	CACAGTTTCTGGTATGTCCAC
SIHKT1;2-S70G Rv	GTGGACATACTAGAAACTGTG
SIHKT1;2-K477Q Fw	GTAATACAGGACAGTTCATTTTG
SIHKT1;2-K477Q Rv	CAAATGAACTGTCCTGTATTAC
SIHKT1;2-R488Q Fw	GTCATGTTTTTTGGACAGTTG
SIHKT1;2-R488Q Rv	CAACTGCCAAAAAACATGAC
SIHKT1;2-K477Q/R488Q/K490Q/K491Q Fw	CATGTTTTTTGGACAGTTGCAGCAGT ATAATC
SIHKT1;2-K477Q/R488Q/K490Q/K491Q Rv	GATTATACTGCTGCAACTGTCCAAAA AACATG
SIHKT1;2-K477Q/R488Q/K490Q/K491Q/R495Q Fw	GCAGTATAATCAACAAGGTGGC
SIHKT1;2-K477Q/R488Q/K490Q/K491Q/R495Q Rv	GCCACCTTGTTGATTATACTTC
SIHKT1;2- K477Q/R488Q/K490Q/K491Q/R495Q/K498Q Fw	GGACAGTTGCAGCAGTATAATCAAC AAGGTGGCCAGGCTTGGAAAG
SIHKT1;2- K477Q/R488Q/K490Q/K491Q/R495Q/K498Q Rv	CTTCCAAGCCTGGCCACCTTGTGA TTATACTGCTGCAACTGTCC
AtHKT1;1-S68G Fw	CAAGAACCCTTCACGTCCTC
AtHKT1;1-S68G Rv	GGAAGATAAGTTGGGTGTTGGA

Preparation of template DNA, *in vitro* transcription and capping of mRNA

All pGEM-HE plasmids containing the mutated *SIHKT1;2* and *AtHKT1;1* genes were digested with NheI in order to make the vector linear downstream of 3'UTR region. Capped and polyadenylated cRNA was synthesized *in vitro* from linearized vector using the mMESSAGE mMACHINE T7 kit (Ambion Inc., USA). Oocytes were obtained from Ecocyte Biosciences (Germany) and injected with 46 ng cRNA in 46 nl of RNase free water or with only RNase free water as a control, and then incubated at 16 °C in ND₉₆ solution supplemented with Na⁺-pyruvate and gentamycin for two days before electrophysiological recordings. Incubation medium was replaced every day.

Two-electrode voltage clamping of *Xenopus* oocytes

Oocytes injected with 46 ng of cRNA were used 2 to 5 days after injection for recording currents induced by the expression of *HKT1* with the two-electrode voltage clamp technique. The voltage-clamp amplifier was an Axoclamp 2A (Axon Instruments, USA). Voltage-pulse protocols, data acquisition, and data analyses were performed using pClamp9 software (Jandel Scientific, Corte Madera, CA). Both membrane potential and current were recorded.

Correction was made for voltage drop through the series resistance of the bath and the reference electrode using a voltage-recording reference in the bath close to the oocyte surface. The first electrode to be inserted in the oocyte was the voltage electrode and, after a stable membrane potential was reached, the current electrode was inserted. Electrodes were filled with a solution of 3 M KCl. Oocytes were bathed according to Uozumi et al. [16]. Osmolality of all solutions was kept between 240 and 260 mosmol/kg with D-mannitol. For IV plots a ramp command was generated. The membrane potential was held at -60 mV and sweeps were made from -140mV to +40mV in 20 mV steps, 1 s duration. Water and *HKT1* cRNA injected oocytes were tested in parallel to ensure the quality of oocytes. The perfusion system used had a flow of 2 ml/sec.

Results

Accessions used to study the natural variation of *HKT1;2* in this Chapter were the same 93 accessions used in Chapter 2 (see Chapter 2 for the full list). Natural variation present in *HKT1* transporters isolated from several plant species was shown to have an important role in the adaptation to salinity stress. As such we decided to assess whether natural occurring SNPs with possible impacts on salinity tolerance were also present in the *HKT1;2* coding sequence of several tomato accessions. Moreover, we also created, artificially, point mutations in the *SIHKT1;2* gene and we tested their effects on the transport properties of the transporter by heterologous expressing these mutated versions of *SIHKT1;2* gene in *Xenopus laevis* oocytes.

***SIHKT1;2* S70 is conserved throughout *Solanum* accessions**

The sequencing and translation of *SIHKT1;2* gene described in Chapter 4 showed that the *SIHKT1;2* transporter, like the *Arabidopsis thaliana* *AtHKT1;1* transporter, has an S at the filter position of the first PD. Due to the proven role of this amino acid in the ion selectivity of several HKT transporters we decided to study the presence of natural variation in this residue amongst 93 different tomato accessions. To test for the presence of natural variation in this residue we performed an HRM analysis. From all 93 tomato accessions tested only 3 (PI 126435, LA 2931 and LA 1401) showed different melting curves (Fig. 1A). To identify whether the SNPs responsible for these different melting curves were located at our target region we amplified and sequenced the region of the first PD of these three accessions (Fig. 1B).

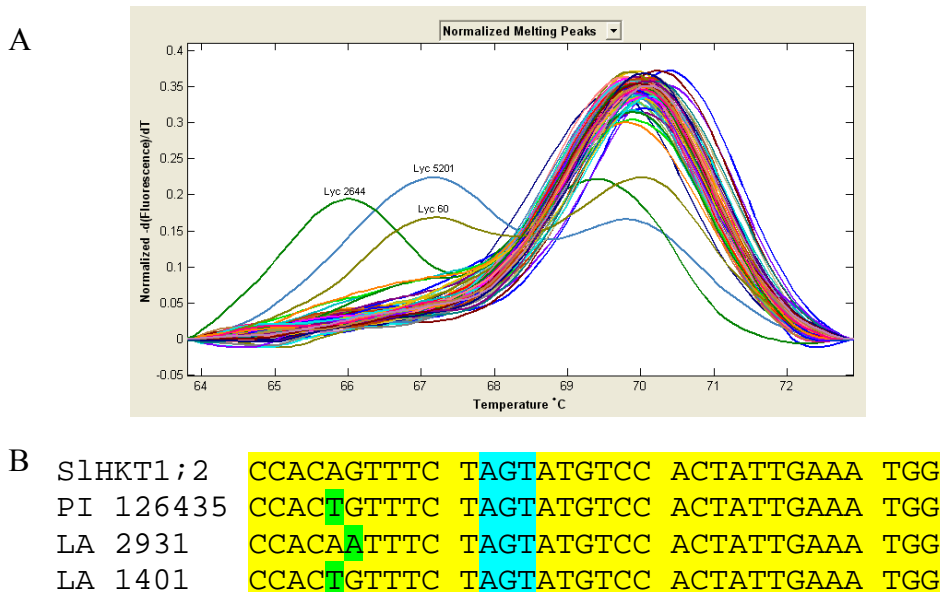

Figure 1: Tomato accessions show SNPs close to the S at the filter position of the first PD but not in the nucleotides coding the S. (A) *Solanum HKT1;2* melting curve derivative plots from 93 tomato accessions showing the two different SNP's identified close to the 1st PD. (B) Nucleotide sequences of the *HKT1;2* gene of different *Solanum* accessions show that both SNPs (green background) situate close to but do not coincide with the S70 residue of the first PD (blue background). Yellow background represents conserved nucleotides.

Sequencing results revealed that each of these three accessions show a single SNP (PI 126435 and LA 1401 have the same SNP and LA 2931 has a different SNP) although none of them in the codon of interest. The SNP in the accession LA 2931 resulted in an amino acid change from valine (V) to isoleucine (I). However, both amino acids are hydrophobic. In the case of accessions PI 126435 and LA 1401 the SNP did not result in any amino acid change as both ACA and ACT code for a threonine (T) residue.

SIHKT1;2 F92 is conserved throughout *Solanum* accessions

Recently, it was shown that the presence of a thymine (T) at position 6392276 bp on chromosome 4 (Chr4:6392276) of *Arabidopsis thaliana* is associated with significantly higher leaf Na⁺ in comparison with accessions with a cytosine (C) [3]. This position lies well within the *AtHKT1;1* coding sequence (bp 268 of *AtHKT1;1*). The presence of either a thymine or a cytosine at this position results in a codon for either an F or an S. The equivalent amino acid in the SIHKT1;2 protein sequence lies at the position 92 of the SIHKT1;2 protein sequence. To study whether polymorphisms in this position also occur in the coding sequence of

Solanum HKT1;2 we designed a probe covering this region and we performed an HRM analysis. Fig. 2A and 2B show that 3 accessions had different melting curves in comparison to the reference *SIHKT1;2* sequence. These accessions were LA 1522, LA 1910 and PI 126443.

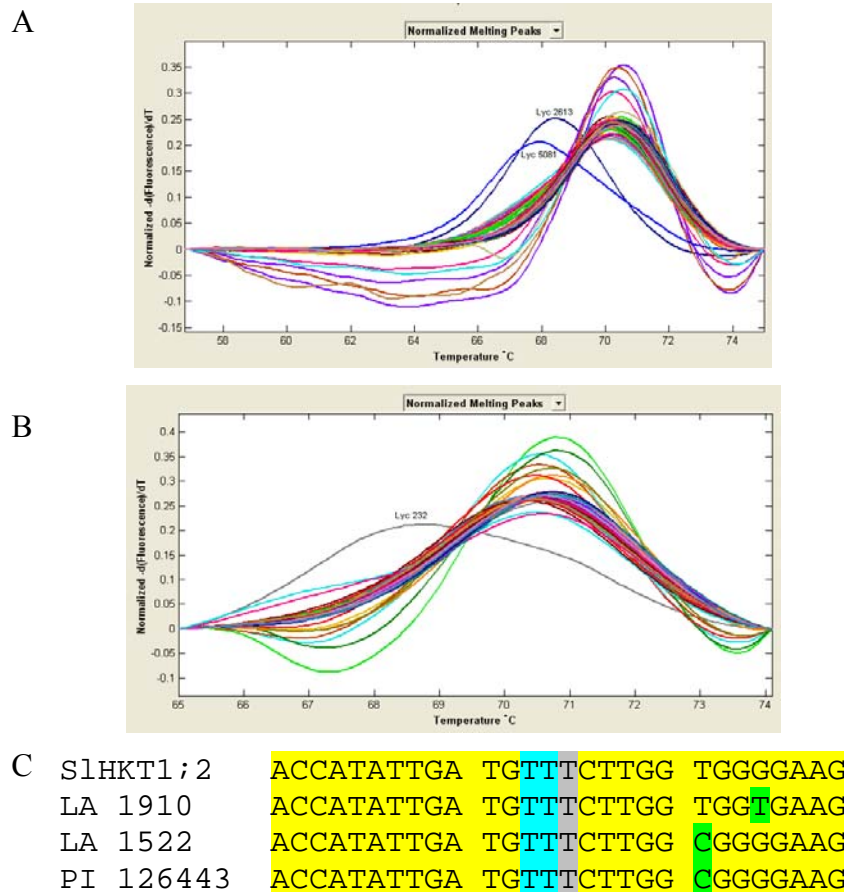

Figure 2: *Solanum HKT1;2* melting curve derivative plot showing two different SNPs identified in (A) batch 1 and one SNP identified in (B) batch 2 close to F92. (C) Nucleotide sequences of the *HKT1;2* gene of different *Solanum* accessions show that the three SNPs (green background) situate close to but do not coincide with the target thymine (grey background) nor the F92 residue of *SIHKT1;2* (blue background). Yellow background marks conserved nucleotides.

Sequencing results showed, that these different melting curves resulted from SNPs present within the region of interest but not the codon of interest. In this region all accessions studied contain a thymine. These SNPs did not result, for any of the accessions studied, in an amino acid change. All combinations of nucleotides (GGT, GGC, GGG) code for a G residue.

SIHKT1;2 N217 and SIHKT1;2 N248 are conserved throughout *Solanum* accessions

In *Thellungiella salsuginea* the presence of two D residues at position 207 and 238 of the TsHKT1;2 protein are responsible for the K⁺ selectivity of the transporter (more than the S residue in the first PD) [8]. *TsHKT1;2* expressing CY162 yeast cells (defective in K⁺-uptake; *Atrk1Δtrk2*), grow well on 10 mM K⁺ in the presence of 300 mM Na⁺, whereas single (D207N or D238N) and double (D207N and D238N) mutants show reduced growth [8].

To test for the presence of these two residues in the HKT1;2 protein sequence from the 93 tomato accessions we designed two HRM probes - probes 14 and 15 (Table 2). Each probe overlaps with the region where N217 and N248 are located in the tomato *HKT1;2* coding sequence and we performed a HRM analysis (Fig. 3A and Fig. 4A). Results for probe 14 (Fig. 3) showed that two accessions (LA 1522 and LA 2560) had different melting peaks when compared with *SIHKT1;2* reference sequence. LA 1522 and LA 2560 were selected and the *HKT1;2* region covering this area amplified and sequenced (Fig 3B).

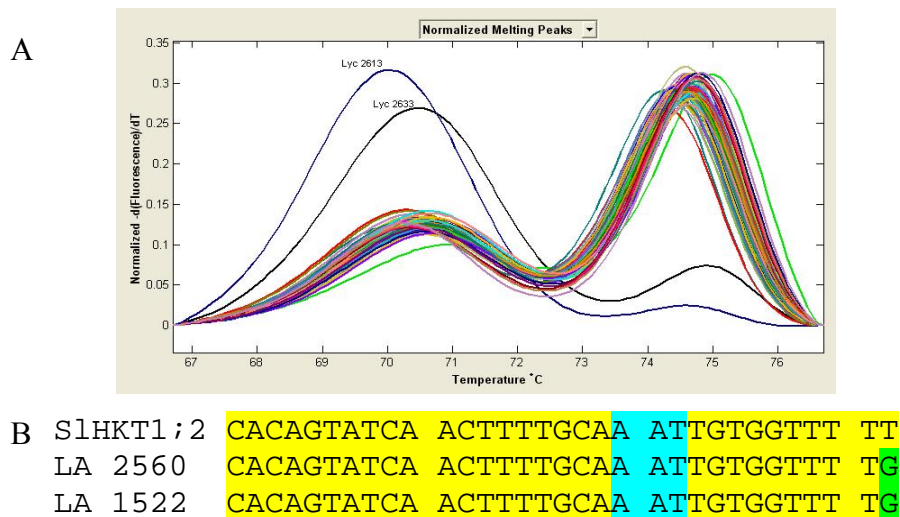

Figure 3: *Solanum HKT1;2* melting curve derivative plot showing (A) two accessions with an SNP identified close N217. (B) Nucleotide sequences of *HKT1;2* gene of different *Solanum* accessions show that the SNP (green background) from both tomato accessions situate close to but do not coincide with any of the nucleotides coding for N217 (blue background) in *SIHKT1;2*. Yellow background marks conserved nucleotides.

The sequencing results obtained for LA 2560 and LA 1522 (Fig. 3B) showed that the SNP located within the probe was not located at our target codon. As the alignment in Fig. 3B shows, the last nucleotide of both accessions was a G whereas our target sequence shows a T. Due to the fact that this SNP is located in the first of three nucleotides coding for an amino

acid and because we don't know the other two nucleotides we cannot conclude whether this SNP resulted in an amino acid change. Nevertheless, both accessions share the same sequence coding for the N residue (AAT).

Results obtained with probe 15 showed a larger number of accessions with different melting curves in comparison to the *SIHKT1;2* melting curve (Fig. 4A). These accessions were: LA 2560, LA 1938, LA 2744, PI 126443, PI 128659, LA 1522, GI 568, PI 126935, LA 1930, PI 126435, LA 2860 and LA 1401.

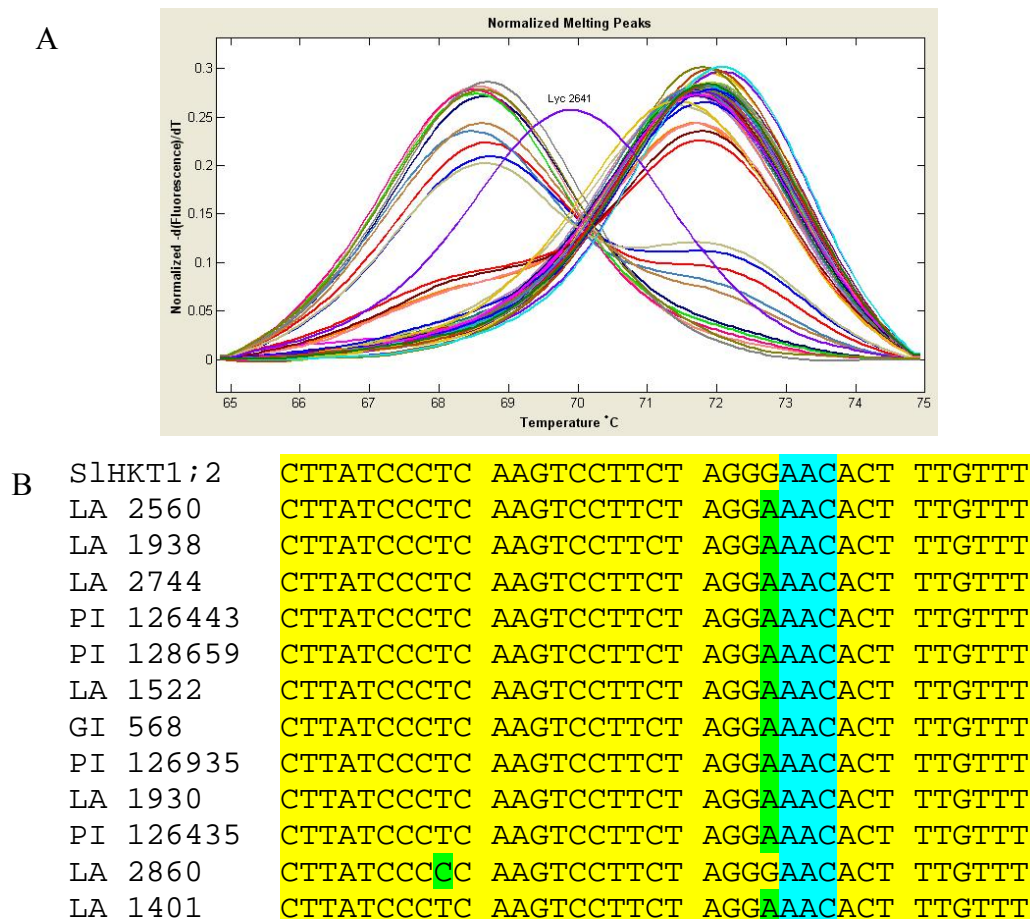

Figure 4: (A) *Solanum HKT1;2* melting curve derivative plot showing the twelve accessions with an SNP identified close to N248 amino acid of SIHKT1;2 (B) Nucleotide sequences of *HKT1;2* gene of different *Solanum* accessions show that the 2 different SNPs (green background) from the twelve tomato accessions situate close to but do not coincide with any of the nucleotides coding for N248 (blue background) in SIHKT1;2. Yellow background marks conserved nucleotides.

Similar to the results obtained with probe 14, the sequencing results obtained with probe 15 showed that these twelve accessions contain a single SNP each (LA 2860 contains a SNP

different from the other accessions) but not located at the position of interest (Fig. 4B). The SNP present in the coding sequence of LA 2860 localizes further away from the target region than the SNP present in the other eleven accessions. None of the identified SNPs did result in an amino acid change. Both GGG and GGA code for a G residue and both CCT and CCC code for a proline (P) residue.

SIHKT1;2 K477 is conserved throughout *Solanum* accessions

In *Synechocystis* KtrB (a member of the Ktr/Trk/HKT superfamily of K⁺ transporters) there is only one positively charged amino acid in the M2_D domain, which is essential for K⁺ transport activity [11]. Unlike *Synechocystis*, plant HKT transporters show several positively charged amino acids in the M2_D domain. Kato et al. [11] showed that by replacing the equivalent positively charged amino acid in AtHKT1;1 (R487) and TaHKT2;1 (R519) the ion transport activity was severely impaired. The replacement of several other positively charged amino acids in the M2_D domain of TaHKT2;1 also resulted in impaired ion transport activity. Based on these results we decided to design probes covering the area where the equivalent positively charged amino acids locate in SIHKT1;2 and check for the presence of natural variance in these residues (Fig 5). From 93 analysed accessions only LA 2639B showed a melting curve different from the reference.

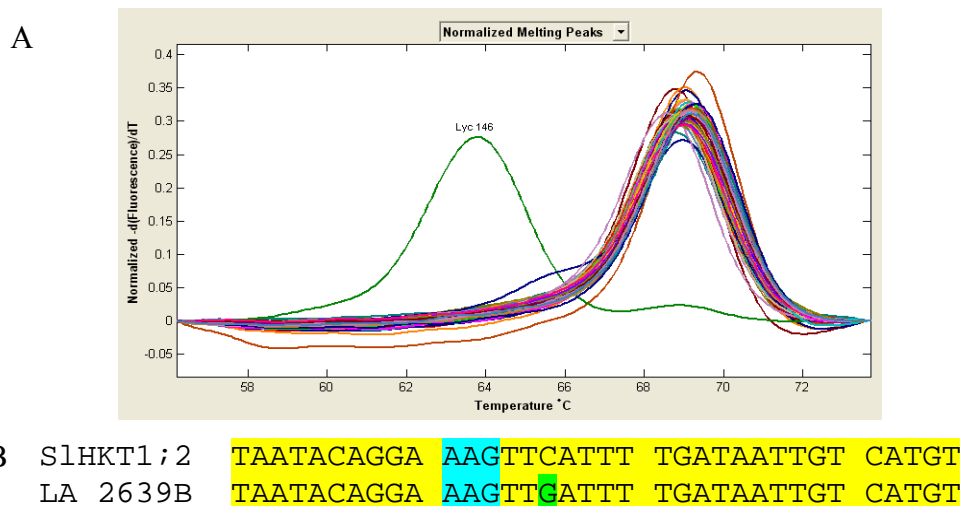

Figure 5: (A) *Solanum HKT1;2* melting curve derivative plot showing one accession with a SNP identified within the probe used to assess natural variation close to the K477 residue of the HKT1;2 protein. (B) Nucleotide sequences of *HKT1;2* gene of *Solanum lycopersicum* and accession LA 2639B show that the SNP (green background) in accession LA 2639B situates

close to but does not coincide with any of the nucleotides coding for K477 (blue background) in *SIHKT1;2*. Yellow background marks conserved nucleotides.

From several probes designed to find natural variation in the positively charged amino acids of the M2_D domain of *Solanum sp.* HKT1;2 only the results obtained with the probe covering the amino acid K477 (Fig. 5B) showed one single accession (LA 2639B) with a different melting curve profile. Sequencing results showed that a single SNP exists in this area between *SIHKT1;2* and LA 2639B *HKT1;2*. *SIHKT1;2* presents a C nucleotide whereas LA 2639B shows a G nucleotide. This SNP was not situated in our codon SNP under the probe. This SNP was responsible for an amino acid substitution (leucine (L) replacing a F). Both amino acids are non-polar amino acids and an effect on ion transport seems unlikely.

Probes designed to access natural variation in the residues R488, K490, K491, R495 and K498 revealed that this area of *Solanum HKT1;2* is conserved among all accessions tested.

Analysis of the effect of mutations introduced in the *SIHKT1;2* gene on transport characteristics

Because no natural variation was observed in the residues of interest we decided to introduce point mutations (Fig. 6) in *SIHKT1;2* that result in an amino acid change and to study the effect of these mutations on the transport activity through heterologous expression in *Xenopus laevis* oocytes.

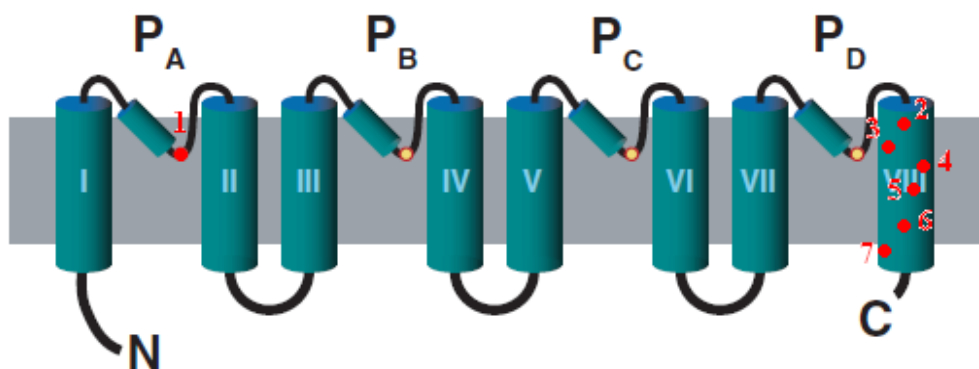

Figure 6: Schematic representation of the point mutations introduced in *SIHKT1;2*. I to VIII represent the membrane domain and P_A to P_D represent the pore domains of *SIHKT1;2*. N represents the N-terminus and C represents the C-terminus of the transporter. 1 till 7 represents the mutations S70G, K477Q, R488Q, K490Q, K491Q, K495Q and K498Q, respectively.

We introduced a single point mutation in the first PD of SIHKT1;2 to replace S70 by a G and also a single point mutation in the first PD of AtHKT1;1 to replace S68 by a G. This construct served as a positive control since it was shown before that this mutation turns the AtHKT1;1 transporter into a Na⁺ and K⁺ symporter [9]. Besides the S70G mutation in SIHKT1;2 we introduced several point mutations in the M2_D domain of SIHKT1;2 to replace K477, R488, K490, K491, K495 and K498 with a glutamine (Q) (Fig. 6). Figure 7 shows the comparison between the M2_D domains of TaHKT2;1, AtHKT1;1 and SIHKT1;2.

TaHKT2;1	505	DGGK	FVLI	ILV	MLY	GRL	KAF	TLAT	GK	529
AtHKT1;1	473	PMGK	FVLI	IIV	MFY	GRFK	QFTA	KSGR		497
SIHKT1;2	474	NTGK	FILI	IIV	MFF	GRL	KKYN	QRGK		498

Figure 7: M2_D domain of three HKT transporters. Blue background represents positively charged residues and yellow background represents conserved residues among the three transporters.

Site-directed mutagenesis of S70 to G of *SIHKT1;2*

To test the hypothesis that S70 of the tomato SIHKT1;2 protein is crucial for the Na⁺ selectivity we replaced S70 by a G (SIHKT1;2-S70G). cRNA of *SIHKT1;2-S70G* was injected in *Xenopus laevis* oocytes. After two days of incubation, currents produced in the presence of Na⁺ and K⁺ ions were recorded in oocytes expressing both wild type and mutated HKT1 transporters from *Arabidopsis thaliana* and *Solanum lycopersicum* (Fig. 8). *AtHKT1;1-S68G* expressing oocytes were used as a positive control [9].

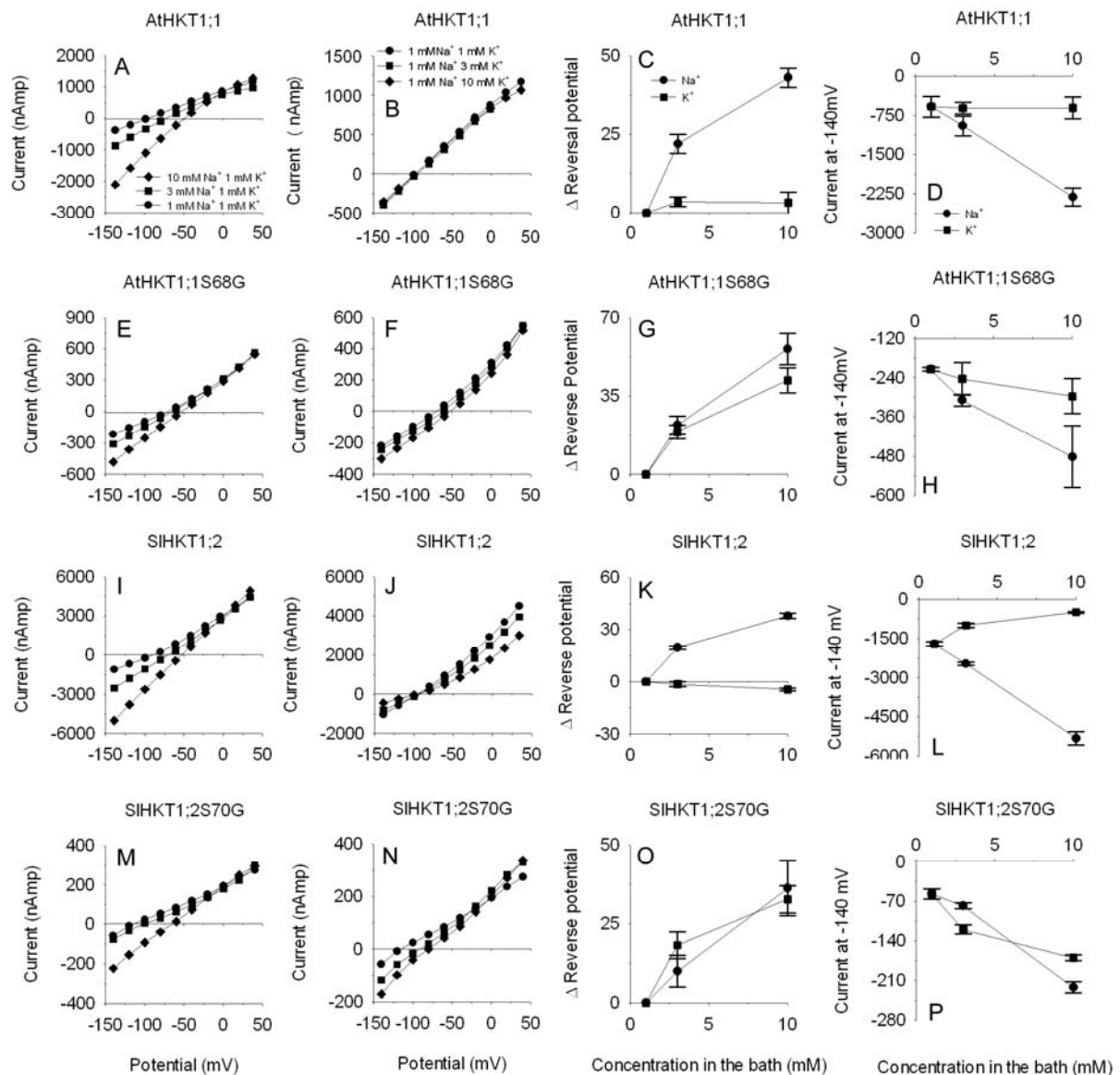

Figure 8: Expression of *AtHKT1;1*, *AtHKT1;1-S68G*, *SIHKT1;2* and *SIHKT1;2-S70G* constructs in *Xenopus laevis* oocytes. Oocytes were injected with *AtHKT1;1* and *SIHKT1;2* and the indicated mutated transporters. (A, E, I, M) Currents recorded at three Na^+ concentrations (1, 3 and 10 mM) with 1 mM K^+ as background; (B, F, J, N) Currents recorded at three K^+ concentrations (1, 3 and 10 mM) with 1 mM Na^+ as background; (C, G, K, O) Reversal potential shifts as a function of ion concentration. Only transporters where the S of the 1st PD was mutated to a G were permeable to K^+ as indicated by the large positive shifts in the reversal potential with increasing concentrations of K^+ in the bath; (D, H, L, P) Absolute currents as a function of ion concentration. Transporters where the S of the 1st PD was mutated to a G showed an increase in current with increasing K^+ concentration in the bath.

Currents produced by oocytes expressing either *AtHKT1;1* (Fig. 8A) or *SIHKT1;2* (Fig. 8I) increased when the oocytes were bathed in higher Na^+ concentrations (as seen by a more negative current). Increasing external $[\text{K}^+]$ did not result in any change in the current levels produced by *AtHKT1;1* expressing oocytes (Fig. 8B). In contrast, *SIHKT1;2* mediated inward and outward currents that were sensitive to external $[\text{K}^+]$ as both currents decreased with increasing bath K^+ concentrations (Fig. 8J). This is an interesting observation. Increased concentrations of K^+ result in an allosteric inhibition on the transport of Na^+ by *SIHKT1;2* but not by *AtHKT1;1*. When oocytes expressing either *AtHKT1;1-S68G* or *SIHKT1;2-S70G* were bathed with either increasing $[\text{Na}^+]$ (Fig. 8E and 8M) or $[\text{K}^+]$ (Fig. 8F and 8N), currents increased for both cations tested. For both *AtHKT1;1*- and *SIHKT1;2*-mediated currents, higher $[\text{Na}^+]$ but not higher $[\text{K}^+]$, resulted in positive shifts in the reversal potential (Figs. 8C and 8K), indicative of Na^+ permeation. Reversal potentials obtained with oocytes expressing either *AtHKT1;1-S68G* (Fig. 8G) or *SIHKT1;2-S70G* (Fig. 8O) showed positive shifts when both $[\text{Na}^+]$ or $[\text{K}^+]$ increased, indicating that the presence of a G residue at the filter position of the first PD allows the transport of both Na^+ and K^+ ions. Figures 8 D, H, L and P show the currents recorded at -140 mV for *AtHKT1;1*, *AtHKT1;1-S68G*, *SIHKT1;2* and *SIHKT1;2-S70G*, respectively. These results show that the Na^+ -mediated current of *SIHKT1;2* is reduced by increased concentrations of K^+ in the bath. This allosteric effect of K^+ ions affects the transport of Na^+ by *SIHKT1;2*. This allosteric effect is not observed with *AtHKT1;1*.

Positively charged amino acids in M2_D helices of the *Solanum* HKT1;2 protein are important for ion transport

Replacement of K477 by Q reduces Na^+ transport

The single substitution K477Q resulted in strong reduction (75%) of Na^+ currents (Fig. 9A), as compared to those mediated by *SIHKT1;2* (Fig. 8I). Combining the K477Q substitution with the S70G substitution (*SIHKT1;2-S70G;K477Q*) resulted in shifts to less negative reversal potentials (Fig. 9G) when both $[\text{Na}^+]$ (Fig. 9E) and $[\text{K}^+]$ (Fig. 9F) in the bath increased. Currents resulting from higher $[\text{K}^+]$ (Fig. 9H) in the bath showed also an increase when the first PD possessed a G. This result indicates that the presence of a G residue at the filter position of the first PD also allows the transport of both Na^+ and K^+ ions by this mutated *SIHKT1;2* transporter.

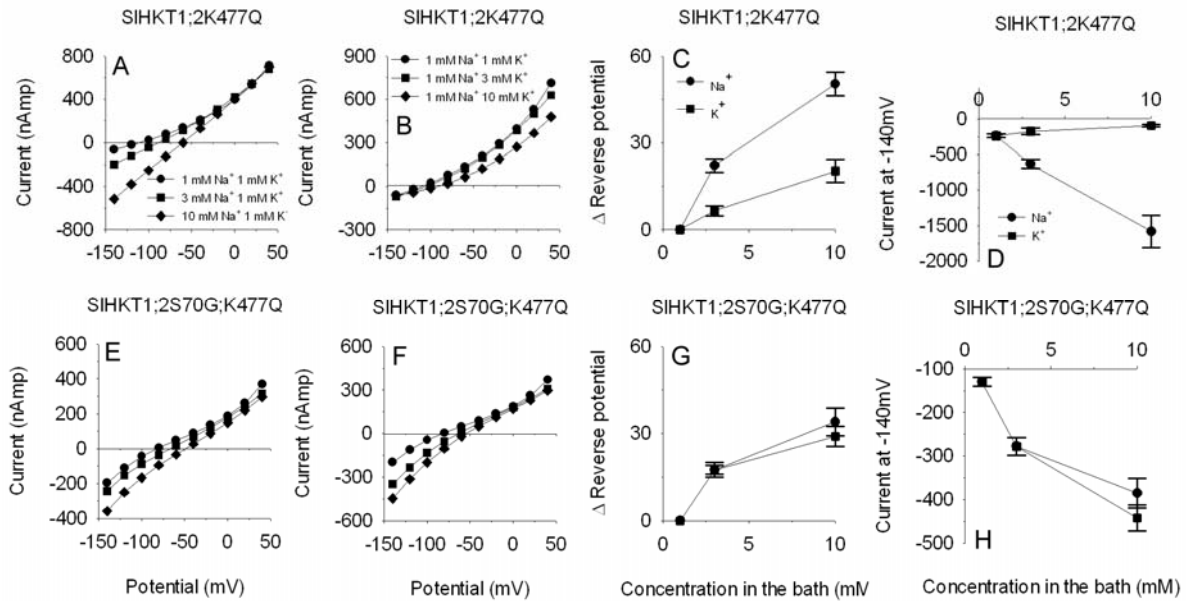

Figure 9: Expression of *SIHKT1;2-K477Q* and *SIHKT1;2-S70G;K477Q* constructs in *Xenopus laevis* oocytes. (A and E) Currents recorded at three Na^+ concentrations (1, 3 and 10 mM) with 1 mM K^+ as background. (B and F) Currents recorded at three K^+ concentrations (1, 3 and 10 mM) with 1 mM Na^+ as background. (C and G) Reversal potential shifts as a function of ion concentration. Only *SIHKT1;2-S70G;K477Q* was permeable to K^+ as indicated by the large positive shifts in the reversal potential with increasing concentrations of K^+ in the bath. (D and H) Absolute currents as a function of ion concentration. Only *SIHKT1;2-S70G;K477Q* showed larger currents with increasing K^+ concentration in the bath.

Replacement of two positively charged amino acids by Q in the M2_D domain of *SIHKT1;2* further reduces Na^+ transport

Oocytes expressing *SIHKT1;2-K477Q;R488Q* showed very small currents (Fig. 10A and B). Compared to wild type and to *SIHKT1;2-K477Q*-mediated currents, this construct showed a reduction of 98,3% and 93,2%, respectively. Nevertheless, the effect of Na^+ in the bath was still observed as higher $[\text{Na}^+]$ resulted in larger currents (Fig. 10A) and shifts of the reversal potential to less negative values (Fig. 10C). Also here, no effect of K^+ in the bath solution was observed. Contrary to *SIHKT1;2-K477Q;R488Q*, *SIHKT1;2-S70G;K477Q;R488Q* resulted in enhanced Na^+ (Fig. 10E) and K^+ (Fig. 10F) currents in comparison to the currents obtained with *SIHKT1;2-K477Q;R488Q* (Fig. 10D). Like the other constructs possessing a G in the first PD, this construct showed shifts to less negative reversal potential values when the concentration of K^+ in the bath was increased (Fig. 10G). Figure 10D and H show the value of both Na^+ and K^+ currents measured at -140 mV.

Two last constructs were tested: *SIHKT1;2-S70G;K477Q;R488Q;K490Q;K491Q* and *SIHKT1;2-S70G;K477Q;R488Q;K490Q;K491Q;R495Q;K498* although the currents recorded were similar to those recorded in water-injected oocytes (data not shown).

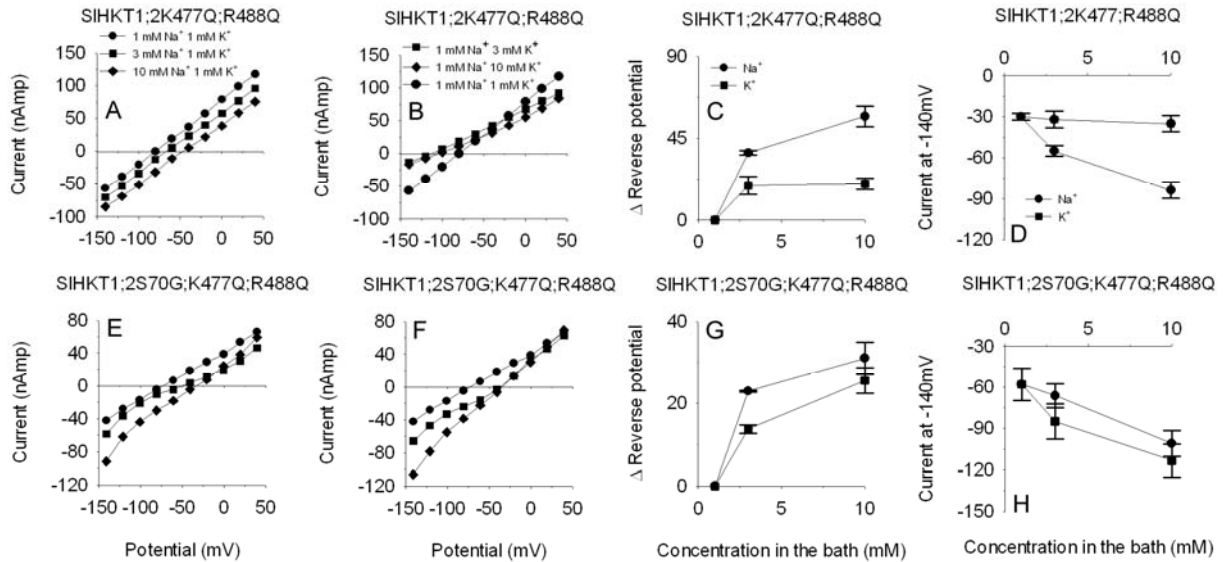

Figure 10: Expression of *SIHKT1;2-K477Q;R488Q* and *SIHKT1;2-S70G;K477Q;R488Q* constructs in *Xenopus laevis* oocytes. (A and E) Currents recorded at three Na⁺ concentrations (1, 3 and 10 mM) with 1 mM K⁺ as background. (B and F) Currents recorded at three K⁺ concentrations (1, 3 and 10 mM) with 1 mM Na⁺ as background. (C and G) Reversal potential shifts as a function of ion concentration. Only *SIHKT1;2-S70G;K477Q;R488Q* was permeable to K⁺ as indicated by the large positive shifts in the reversal potential with increasing concentrations of K⁺ in the bath. (D and H) Absolute currents as a function of ion concentration. Only *SIHKT1;2-S70G;K477Q;R488Q* showed increments in current with increasing K⁺ concentration in the bath.

Table 3 summarizes all Na⁺ and K⁺ currents measured with all constructs analysed in this study. A number of interesting differences between the response of the *Arabidopsis* HKT1 and tomato HKT1;2 and some mutants to increasing K⁺ in the bath are plotted in Fig. 11: i) the S to G mutation induces a much stronger reduction in current in tomato as compared to *Arabidopsis*, ii) the current mediated by *SIHKT1;2* is strongly reduced by increasing concentration of K in the bath, whereas that mediated by *AtHKT1* is not and iii) the current mediated by the S70G-K477Q double mutant is much higher than that mediated by the S70G single mutant. So, whereas both the S70G and K477Q single mutations strongly reduce the current, this effect is ameliorated by combining both mutations in the same protein.

Table 3: Summary of currents recorded at -140 mV for all solutions and constructs tested. SIHKT1;2-S70G;K477Q;R488Q;K490Q;K491Q and SIHKT1;2-S70G;K477Q;R488Q;K490Q;K491Q; R495Q;K498Q currents were not considered as their values were similar to those obtained with water injected oocytes and also because no response to increasing concentrations of Na⁺ or K⁺ were observed.

	Value of currents recorded at -140 mV (nAmp)				
	Salts concentration (mM)				
	1 Na 1K	1Na 3 K	1 Na 10 K	3 Na 1 K	10 Na 1 K
SIHKT1;2	-1115	-820	-435	-2531	-5015
SIHKT1;2-S70G	-57	-117	-170	-74	-222
SIHKT1;2-K477Q	-62	-70	-61	-198	-516
SIHKT1;2-S70G;K477Q	-196	-348	-446	-242	-357
SIHKT1;2-K477Q;R488Q	-56	-13	-17	-70	-84
SIHKT1;2-S70G;K477Q;R488Q	-42	-58	-91	-65	-91
AtHKT1;1	-382	-397	-354	-868	-2103
AtHKT1;1-S68G	-218	-240	-300	-308	-482

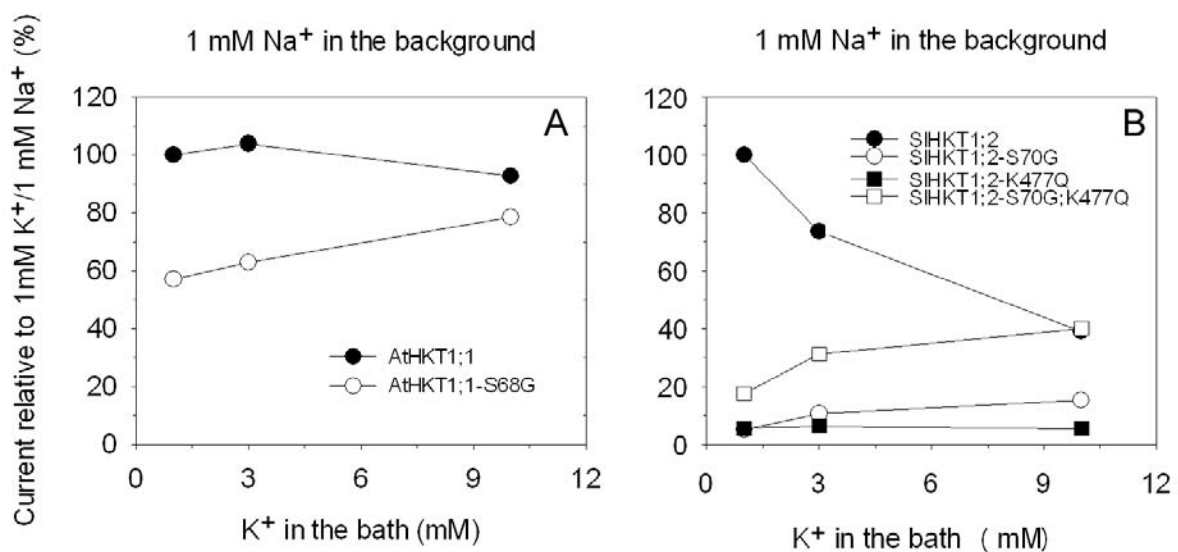

Figure 11: Differences between the response of (A) AtHKT1;1 and (B) SIHKT1;2 wild type and mutated forms to increasing K⁺ concentrations in the bath. The replacement of S by a G in the first PD induces stronger reduction in current in SIHKT1;2 than AtHKT1;1. SIHKT1;2 current is inhibited by K⁺ whereas AtHKT1;1 is not. The current mediated by the SIHKT1;2-S70G-K477Q double mutant is much higher than that mediated by the SIHKT1;2-S70G single mutant

Discussion

Several studies have shown that SNPs in genes involved in Na⁺ and K⁺ homeostasis can have a dramatic effect on the salinity tolerance of several plant species. That is the case for HKT transporters [3-5,8,17]. Based on the effects that these naturally occurring SNPs in the HKT sequence have on the HKT transport properties and in the salinity tolerance of these species, we decided to study whether comparable SNP's were also present in the HKT sequence of a wide range of tomato accessions. In the first PD all accessions studied showed an S, like AtHKT1;1. Previous studies (see Chapter 4) on properties of the heterologous expressed *SIHKT1;2* showed that the transport characteristics were in accordance with the presence of an S in the first PD of the transporter. The comparison of two *Arabidopsis* accessions (Tsu and Ts) [3,6] showed that in *AtHKT1;1*, the presence of either a T or C at position Chr4:6392276, coding for a phenylalanine (F) (TTC) or a serine (S) (TCC), respectively, correlated with high or low leaf Na⁺ concentrations, respectively [3,6]. In tomato HKT1;2 the equivalent residue localizes at position 92 and all accessions showed an F residue indicating that no natural variation exists at this position. The analysis of the amino acid residues present at positions 217 and 248 (homologous to position 207 and 238 in *Thellungiella salsuginea*) showed that both regions were conserved among all tomato accessions. Like in *Arabidopsis thaliana*, but in contrast to *Thellungiella salsuginea*, all tomato accessions showed an N residue at these two positions. This is reflected in the *SIHKT1;2* characteristics as measured in heterologous expression (see Chapter 4) where it was shown that tomato HKT1;2 transports Na⁺ but not K⁺, as was observed with *Thellungiella salsuginea* [8]. The last region of the tomato HKT1;2 analysed was the M2_D domain. In this region several positively charged residues are present which are known to have a crucial role in the functioning of the transporter [10,11]. Although some residue differences were observed (Fig. 7), this is nevertheless a very conserved region among HKT transporters.

In conclusion, all target regions analysed showed that none of the known SNPs that affect transport properties of HKT1 is present in the tomato accessions tested. Since the analysis included many wild accessions that are known to be rather salt tolerant, we conclude that if during evolution the amino acid residues that we studied did change, these changes were not in favour of salinity tolerance of the tomato plants and therefore did not persist [10].

SIHKT1;2 mediated Na⁺ transport is K⁺-sensitive; allosteric inhibition.

A striking difference between the transport properties of AtHKT1 and *SIHKT1;2* expressed in oocytes was observed when currents were measured at constant Na⁺ in the bath (1 mM) and

increasing K^+ (1, 3 and 10 mM). Whereas the AtHKT1 mediated current was virtually insensitive to higher K^+ , the SIHKT1;2 mediated current decreased by 60% at 10 mM K^+ (Fig. 11). This indicates that K^+ acts as an allosteric inhibitor of Na^+ -currents. A similar inhibitory action of K^+ on HKT-mediated currents was reported for OsHKT2;1 [18] and for TmHKT1;5-A [19]. It was proposed that this inhibition is caused by the association of K^+ to the Na^+ binding region within the pore region of HKT transporters [17,20]. This inhibition has not been observed with AtHKT1;1 [16] nor OsHKT1;5 [4] in *Xenopus* oocytes, which indicates that the K^+ -sensitivity of these transporters is different from those of OsHKT2;1, TmHKT1;5-A and the tomato SIHKT1;2. Physiologically, this K^+ -induced reduction of Na^+ -influx could mean that the tomato plants maintain a certain K^+/Na^+ homeostasis in the transpiration sap that flows towards the shoot, as high K^+ -concentrations in the xylem sap imply a reduced Na^+ -uptake into the Xylem Parenchyma Cells (XPCs) and vice versa (Fig. 12). Although the S \rightarrow G mutation in the first pore domain of both the AtHKT1 and SIHKT1;2 protein had an effect on the ion selectivity of both transporters, as deduced from the shift in reversal potential at increasing external K^+ (Fig. 8), a major difference observed was the reduction in total current transported by SIHKT1;2-S70G and AtHKT1-S68G, which was 95 and 78% respectively of that transported by the wild-type proteins at 10 mM Na^+ and 1 mM K^+ in the bath (Table 3 and [9]). The reason for this difference is not clear yet.

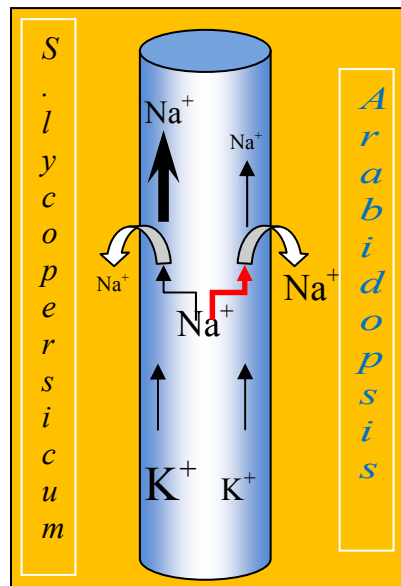

Figure 12: Model depicting the difference in K^+ -sensitivity of SIHKT1;2 from *S. esculentum* and AtHKT1 from *Arabidopsis*. When the K^+ -concentration in the xylem sap is high, Na^+ -uptake by the SIHKT1;2 transporter is reduced, but Na^+ -uptake in the XPCs by the AtHKT1;1 transporter is not affected by high Na^+ . As a result, homeostasis of the Na^+/K^+ ratio of the

transpiration stream reaching the tomato shoot tissue is controlled by the supply of K^+ in the xylem.

Mutations introduced in the M2_D region of SIHKT1;2

Although no natural variance was observed in the regions of interest amongst all tomato accessions studied, we were interested to study the effect of neutralization of positively charged residues of the M2_D region (in combination with the first pore mutation, S70G) on the SIHKT1;2 transport properties. We created several constructs carrying different single and multiple mutations and we tested the transport properties of these mutated proteins via heterologous expression in *Xenopus laevis* oocytes. In the M2_D domain we chose to neutralize the positively charged K and R residues (Fig. 11) to the uncharged Q because it is known that charged residues [10] in the M2_D domain are important for the function of HKT transporters [11]. In SIHKT1;2 the neutralization of the positively charged residues of M2_D reduced the flux rates of Na^+ . This is in accordance with studies on HKT transporters [10,11], but also on cardiac Ca^{2+} channels, where the neutralization of charged amino acid residues reduced the flux and channel's activity for Na^+ and K^+ , and Ca^{2+} , respectively [21]. The replacement of SIHKT1;2-K477Q (homologous to TaHKT2;1-K508Q) resulted in a 75.5% reduction in Na^+ currents in comparison to SIHKT1;2 when 10 mM Na^+ and 1 mM K^+ were present in the bath solution. Although Kato et al. [11] report a reduction in currents due to the K508Q substitution in TaHKT2;1, our results showed a larger current reduction when K477 is mutated to Q in SIHKT1;2. Subsequent stacking of more replacements of positively charged residues for a Q resulted in much stronger reductions in current and, eventually, in currents similar to currents recorded in water-injected oocytes. This was also observed for SIHKT1;2 transporter where the S from the first PD was replaced by G, indicating that this same effect of mutating positively charged amino acids from the M2_D domain also occurs for K^+ currents (Fig. 11). Interestingly, the presence of both the S70G and K477Q mutation (SIHKT1;2-S70G-K477Q) resulted in currents that were less reduced than the currents produced by SIHKT1;2-S70G, as compared to the currents with the wild-type protein, SIHKT1;2. Addition of the R488Q mutation to SIHKT1;2-S70G-K477Q annihilated the positive cooperativity of the S70G-K477Q mutations (Table 3).

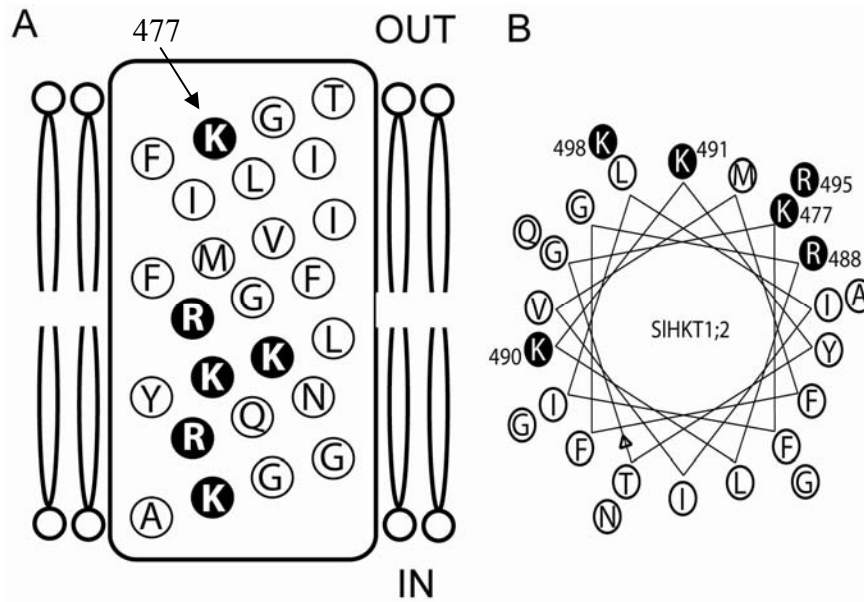

Figure 13: Spatial distribution of positively charged amino acids in the M2_D domain of SIHKT1;2. (A) Proposed membrane topology model for the M2_D transmembrane helices of SIHKT1;2. (B) Spatial arrangement of SIHKT1;2 M2_D viewed from above. Positively charged amino acids are marked as closed circles.

As proposed by Kato et al. [11], the reduction in transport activity of the M2_D mutations is likely due to the fact that the positively charged amino acids present in the M2_D domain interact with conserved negatively charged residues (D or E) in the P_A and P_D domains of plant HKT transporters [11]. Since the proposed membrane topology model of the M2_D helix shows that of all positively charged residues K477 is closest to the outer surface of the helix (Fig. 13), we hypothesize that this outer domain of the M2_D helix is in contact with the first pore domain where S70 is present. In analogy with the wheat TaHKT2;1 protein, the positively charged K477 residue in SIHKT2;1 may interact with the negatively charged glutamic acid residue (E75 in tomato, corresponding to D78 in TaHKT2;1) present in the beginning of the P_A domain. The close proximity of E75 to the critical first pore domain amino acid S70 may explain why we observe “cross-talk” between S70 and K477, as deduced from the transport properties of the SIHKT2;1-S70G;K477W double mutant (Fig. 11). The other positively charged amino acids present further downstream in the M2_D domain form salt bridges with negatively charged amino acids in the P_D domain [11] and the loss-of-function phenotype observed with additional mutations in positively charged residues (R488Q;K490Q;K491Q;R495Q;K498Q) is probably the result of loss of salt bridges, affecting the three-dimensional structure of the protein.

In conclusion, no natural variance was found to be present in any of the target regions of the *Solanum sp.* HKT1;2 transporter analysed in this study. When the S present in the first PD of SIHKT1;2 is replaced by G the transporter behaves as a Na⁺ and K⁺ transporter. Stacking of mutations in the positively charged amino acids of the M2_D domain are additive with respect to reducing the transport capacity, and four or more stacked mutations result in a loss-of-function phenotype of the transporter. The most interesting mutant that we generated is SIHKT1;2-S70G;K477Q, because this protein has the capacity to transport both Na⁺ and K⁺ at a reasonable rate. We will study the functionality of this mutant *in vivo* by complementation of the *Arabidopsis athkt1;1* mutant during exposure to mild salt stress (Chapter 6). In contrast to the *Arabidopsis* AtHKT1 transporter, Na⁺-transport by the tomato SIHKT1;2 protein is allosterically inhibited by the presence of K⁺ at the outside of the membrane. An interesting question is whether this regulation mechanism is physiologically relevant for controlling Na⁺/K⁺ homeostasis of the xylem sap flowing from the roots to the shoot.

References

1. Mian A, Oomen RJ, Isayenkow S, Sentenac H, Maathuis FJ, et al. (2011) Overexpression of a Na⁺ and K⁺-permeable HKT transporter in barley improves salt tolerance. *Plant Journal* 68: 468-479.
2. Munns R, Tester M (2008) Mechanisms of salinity tolerance. *Annual Review of Plant Biology* 59: 651-681.
3. Baxter I, Brazelton JN, Yu DN, Huang YS, Lahner B, et al. (2010) A Coastal cline in sodium accumulation in *Arabidopsis thaliana* is driven by natural variation of the sodium transporter AtHKT1;1. *PloS Genetics* 6.
4. Ren ZH, Gao JP, Li LG, Cai XL, Huang W, et al. (2005) A rice quantitative trait locus for salt tolerance encodes a sodium transporter. *Nature Genetics* 37: 1141-1146.
5. Cotsaftis O, Plett D, Shirley N, Tester M, Hrmova M (2012) A two-staged model of Na⁺ exclusion in rice explained by 3D modeling of HKT transporters and alternative splicing. *PLoS One* 7: e39865.
6. Rus A, Baxter I, Muthukumar B, Gustin J, Lahner B, et al. (2006) Natural variants of AtHKT1 enhance Na⁺ accumulation in two wild populations of *Arabidopsis*. *PloS Genetics* 2: 1964-1973.
7. Baek D, Jiang JF, Chung JS, Wang BS, Chen JP, et al. (2011) Regulated *AtHKT1;1* gene expression by a distal enhancer element and DNA methylation in the promoter plays an important role in salt tolerance. *Plant and Cell Physiology* 52: 149-161.
8. Ali Z, Park HC, Ali A, Oh D-H, Aman R, et al. (2012) TsHKT1;2, a HKT1 homolog from the extremophile *Arabidopsis* relative *Thellungiella salsuginea*, shows K⁺ specificity in the presence of NaCl. *Plant Physiology* 158: 1463-1474.
9. Maser P, Hosoo Y, Goshima S, Horie T, Eckelman B, et al. (2002) Glycine residues in potassium channel-like selectivity filters determine potassium selectivity in four-loop-per-subunit HKT transporters from plants. *Proceedings of the National Academy of Sciences of the United States of America* 99: 6428-6433.
10. Diatloff E, Kumar R, Schachtman DP (1998) Site directed mutagenesis reduces the Na⁺ affinity of HKT1, an Na⁺ energized high affinity K⁺ transporter. *FEBS Letters* 432: 31-36.

11. Kato N, Akai M, Zulkifli L, Matsuda N, Kato Y, et al. (2007) Role of positively charged amino acids in the M2_D transmembrane helix of Ktr/Trk/HKT type cation transporters. *Channels* 1: 161-171.
12. Kennerson L, Warburton T, Nelis E, Brewer M, Polly P, et al. (2007) Mutation scanning the *GJB1* gene with high resolution melting analysis: implications for mutant scanning of genes for Charcot-Marie-Tooth disease. *Clinical Chemistry* 53: 349-352.
13. Mondini L, Nachit M, Porceddu E, Pagnotta MA (2012) Identification of SNP mutations in *DREB1*, *HKT1*, and *WRKY1* genes involved in drought and salt stress tolerance in durum wheat (*Triticum turgidum* L. var *durum*). *Journal of Integrative Biology* 16: 178-187.
14. Liew M, Pryor R, Palais R, Meadows C, Erali M, et al. (2004) Genotyping of single-nucleotide polymorphisms by high-resolution melting of small amplicons. *Clinical Chemistry* 50: 1156-1164.
15. Raghavendra A, Siji A, Sridhar TS, Phadke K, Vasudevan A (2011) Evaluation of high resolution melting analysis as an alternate tool to screen for risk alleles associated with small kidneys in Indian newborns. *Nephrology* 12.
16. Uozumi N, Kim EJ, Rubio F, Yamaguchi T, Muto S, et al. (2000) The *Arabidopsis HKT1* gene homolog mediates inward Na⁺ currents in *Xenopus laevis* oocytes and Na⁺ uptake in *Saccharomyces cerevisiae*. *Plant Physiology* 122: 1249-1259.
17. Rubio F, Gassmann W, Schroeder JI (1995) Sodium-driven potassium uptake by the plant potassium transporter HKT1 and mutations conferring salt tolerance. *Science* 270: 1660-1663.
18. Jabnoue M, Espeout S, Mieulet D, Fizames C, Verdeil JL, et al. (2009) Diversity in expression patterns and functional properties in the rice HKT transporter family. *Plant Physiology* 150: 1955-1971.
19. Munns R., James RA, Xu B, Athman A, Conn JS, et al. (2012) Wheat grain yield on saline soils is improved by an ancestral Na⁺ transporter gene. *Nature Biotechnology* 30: 360-364.
20. Gassmann W, Rubio F, Schroeder JI (1996) Alkali cation selectivity of the wheat root high-affinity potassium transporter HKT1. *Plant Journal* 10: 869-882.
21. Parent L, Gopalakrishnan M (1995) Glutamate substitution in repeat IV alters divalent and monovalent cation permeation in the heart Ca²⁺ channel. *Biophysical Journal* 69: 1801-1813.

Chapter 6

***Arabidopsis HKT1;1* and tomato *HKT1;2* partly rescue the salt sensitive phenotype of the *athkt1;1* mutant**

Pedro Almeida^{1*}, Richard Feron², Gert-Jan de Boer² and Albertus H. de Boer¹

¹Vrije Universiteit Amsterdam, Faculty Earth and Life Sciences, Department of Structural Biology, NL-1081 HV Amsterdam, the Netherlands

²Enza Zaden, Oosterdijk Gebouw, P. O. Box 7, 1600 AA Enkhuizen

*Corresponding author: p.m.fidalgodealmeida@vu.nl

Abstract

Maintaining cellular ion homeostasis during salinity stress is an important strategy for plant survival when soil salt levels rise. One transporter of major importance for Na⁺/K⁺ homeostasis in *Arabidopsis* is HKT1, the only member in *Arabidopsis* of the *HKT* (high-affinity potassium transporter) gene family, which includes Na⁺ and Na⁺/K⁺ transporters in diverse plant species. Although the role of HKT transporters has been studied *in planta*, information on molecular properties of HKT proteins (affinity, selectivity and activity) has been generated using heterologous expression systems like *Xenopus laevis* oocytes and *Saccharomyces cerevisiae* cells. Here, we addressed the question whether certain properties of HKT transporters as measured in oocytes, are also reflected in the physiology of a plant, or whether heterologous expression systems are too artificial to have physiological meaning *in planta*?

In the two previous Chapters we characterized the transport properties of AtHKT1;1, the tomato homologue SlHKT1;2 and several mutated versions of these proteins through heterologous expression in *Xenopus* oocytes. The properties of these HKT proteins were sufficiently diverse to warrant further *in planta* study by expressing the genes encoding these proteins in the background of the *Arabidopsis hkt1* mutant, *athkt1;1*. All genes were expressed behind the 5 kb long endogenous *AtHKT1;1* promoter. As expected, the *AtHKT1;1* and *SlHKT1;2* wild type genes complemented the *athkt1;1* mutant growth phenotype.

Whereas they also restored the accumulation of K^+ in the shoot, the low accumulation of Na^+ as shown by WT plants was only partially restored. The reason for this difference is not clear so far. The allosteric inhibition of Na^+ transport by K^+ shown by the *SIHKT1;2* transporter in oocytes (and not by *AtHKT1;1*), was not reflected in Na^+ accumulation in the plants transformed with *SIHKT1;2*. The second *HKT* gene identified in tomato, *SIHKT1;1*, was not active in the oocyte system and also failed to complement the *athkt1;1* mutant. All other transgenic lines with the mutated *AtHKT1;1* and *SIHKT1;2* genes did not show any differences in Na^+ or K^+ accumulation as compared to *athkt1;1* plants. Further analysis under more controlled growth conditions of Na^+ and K^+ supply may be necessary to visualize the change in ion selectivity of some of these mutated genes. From our observation that complementation of the *athkt1;1* mutant with *HKT* genes, having a single point mutation in the first pore domain, leaves the enhanced Na^+ and reduced K^+ shoot accumulation unaffected, we conclude that the *AtHKT1;1* protein affects K^+ -loading in the xylem through membrane depolarization rather than through direct interaction with a K^+ -efflux transporter. This suggests that the depolarization activated K^+ -efflux channel SKOR is a major determinant of K^+ -homeostasis in the leaves during salinity stress.

Introduction

Salinity stress negatively affects potential crop yield [1]. In order to sustain the growing human population it is necessary to increase the salt tolerance of crop plants, as the human population is growing faster than the area of agricultural land [2]. To tolerate salinity, plants rely on three different mechanisms: osmotic tolerance, ionic tolerance and Na^+ exclusion from the shoots [1]. Na^+ exclusion from the shoots is the most studied and best understood mechanism, therefore, it is a promising candidate for an approach of genetic modification to enhance plant salt tolerance [3].

HKT transporters are the most studied transporters with regard to Na^+ exclusion from the shoots. HKT transporters belong to a superfamily of transporters including bacterial KtrBs transporters [4] and yeast TRKs transporters [5]. The *HKT* gene family is divided in two classes based on their gene structure and in the presence of either a glycine (G) or a serine (S) residue in the first pore loop of the transporter [6]. Members of class 1 have an S at this position, whereas members of class 2, with the exception of *OsHKT2;1*, have a G at this position [7]. HKT transporters are implicated in Na^+ transport in wheat [8-11], rice [12-14] and *Arabidopsis* [15-19]. Class I HKT transporters are low affinity transporters with specificity for Na^+ [1]. Some of these members are located at the plasma membrane of root

stele cells, in particular, xylem parenchyma cells (XPC). They function in retrieving Na^+ from the xylem sap and prevent Na^+ from reaching the shoots and damaging photosynthetic cells. The number of class I HKT members varies between mono- and dicotyledonous plants [12,13,20,21]. When first characterized, *athkt1;1* and wild type seedlings showed no difference in root and shoot growth after growing 6 days in a medium with (150 mM) or without NaCl [17]. On the long term however, medium supplemented with 75 mM NaCl reduced the shoot growth and increased tip senescence of mature leaves of *athkt1;1* mutants [17]. Due to the higher Na^+ accumulation in the shoots *athkt1;1* mutant plants display Na^+ sensitivity showing the role of HKT transporters in avoiding Na^+ from reaching the shoots [16-18,22].

Although the role of HKT transporters has been studied *in planta* [8,9,12,16,17,19,22-29], much data is still generated from heterologous expression of HKT transporters mainly in *Xenopus laevis* oocytes [12,13,15,16,30-38] and, to a lesser extent, in *Saccharomyces cerevisiae* cells [20,33-35,38-40]. In a report by Haro et al. [41] a very important question was addressed: are results obtained for HKT transporters when expressed in heterologous systems of physiological importance *in planta*? [41]. Or, are heterologous expression systems too artificial to have a or any physiological meaning *in planta*? In the previous Chapter, we studied the effect of specific amino acid replacements in the SIHKT1;2 transport properties when expressed in *Xenopus laevis* oocytes. In this study we transformed *athkt1;1* (N6531) mutant plants with *AtHKT1;1*, *SIHKT1;1* and *SIHKT1;2*, and with several of the mutated transporters studied in Chapter 5, namely *AtHKT1;1-S68G*, *SIHKT1;2-S70G* and *SIHKT1;2-S70G;K477Q*. We used these complementation experiments to answer a number of questions. First, is the *in planta* function of SIHKT1;2 under salt stress comparable to the function of *AtHKT1;1*, or does the difference in allosteric inhibition (observed in Chapter 4 and Chapter 5) of Na^+ transport by K^+ result in differences in Na^+ homeostasis? Second, how does expression of the *AtHKT1;1-S68G*, *SIHKT1;2-S70G* and *SIHKT1;2-S70G;K477Q* mutants and *SIHKT1;1* under the *AtHKT1;1* endogenous promoter affect Na^+ and K^+ homeostasis of the *athkt1;1* mutant plants? And third, do the results on transport properties obtained with *Xenopus* oocytes agree with the Na^+ accumulation in the shoots of *athkt1;1* plants transformed with *AtHKT1;1*, *SIHKT1;1* and *SIHKT1;2*, *AtHKT1;1-S68G*, *SIHKT1;2-S70G* and *SIHKT1;2-S70G;K477Q*. To answer these questions, we generated stable lines expressing each of these constructs, and we characterized their biomass production, shoot water content and ion content. The analysis of shoot fresh weight showed no significant differences between the lines when treated with 100 mM NaCl for two weeks. Both *AtHKT1;1prom::AtHKT1;1* and

AtHKT1;1prom::SIHKT1;2 expressing lines showed reduced Na⁺ and higher K⁺ accumulation in comparison to *athkt1;1* and the other transgenic lines. Although the K⁺ accumulation of these two transgenic lines was similar to wild type plants, the Na⁺ accumulation was significantly higher. Transgenic lines expressing *AtHKT1;1-S68G* or *SIHKT1;2-S70G* or *SIHKT1;1-S70G;K477Q* or *SIHKT1;1* did not complement the salinity sensitive phenotype of *athkt1;1* plants. The results of this study show that transport activity results obtained with heterologous systems do not always correspondent with results obtained *in vivo*.

Material and methods

Plant material and growth conditions

Seeds of homozygous *athkt1;1* mutant (Columbia-0) were obtained from the NASC stock centre (N6531), and sown along with WT *Arabidopsis thaliana* Col-0. Plants were grown on a mix of sand and peat (1:1) at 24 °C in a 16 h light/8 h dark cycle in a greenhouse. Plants were watered every two days. Selected transgenic lines (See below for a full description of how these lines were generated) were grown under the same conditions. Four-week old transgenic lines (T2 lines) were treated with 100 mM NaCl every two days during two weeks before harvesting of shoot material.

Cloning of *HKT* genes and generation of *Arabidopsis* transgenic lines

pGEM-HE+AtHKT1;1, *pGEM-HE+AtHKT1;1-S68G*, *pGEM-HE+SIHKT1;2*, *pGEM-HE+SIHKT1;2-S70G*, *pGEM-HE+SIHKT1;2-S70G;K477Q* and *pGEM-HE+SIHKT1;1* (see Chapter 4 for more information about how these constructs were made) were used as template in the amplification of the *HKT* genes flanked by the *attB* Gateway (Invitrogen) recombination sites. The *AtHKT1;1*, *AtHkt1;1-S68G*, *SIHKT1;2*, *SIHKT1;2-S70G*, *SIHKT1;2-S70G;K477Q* and *SIHKT1;1* genes were cloned into the *pDONR221 P5-P2* vector (Invitrogen) and were named *p5-2AtHKT1;1*, *p5-2AtHkt1;1-S68G*, *p5-2SIHKT1;2*, *p5-2SIHKT1;2-S70G*, *p5-2SIHKT1;2-S70G;K477Q* and *p5-2SIHKT1;1*, respectively. A 5 kb DNA fragment upstream of the *ATG* start codon of the *AtHKT1;1* gene containing the promoter region, the tandem repeat and the small RNA target region [27] was cloned into *pDONR221 P1-P5* and *pDONR221 P1-P2* (Invitrogen) and were named *p1-5AtHKT1;1prom*, *p1-2AtHKT1;1prom*, respectively. Cloning of DNA fragments into *pDONR221* (Invitrogen) vectors was performed by BP reactions (Invitrogen). Cloning of either *AtHKT* or *SIHKT* genes into *pHGW* [42] under the *AtHKT1;1* promoter was performed by LR reactions (Invitrogen). In this way, *pHGW+AtHKT1;1prom+AtHKT1;1*, *pHGW+AtHKT1;1prom+AtHKT1;1-S68G*,

pHGW+AtHKT1;1prom+SIHKT1;2, *pHGW+AtHKT1;1prom+SIHKT1;2-S68G*, *pHGW+AtHKT1;1prom+SIHKT1;2-S68G;K477Q* and *pHGW+AtHKT1;1prom+SIHKT1;1* constructs were created. *p1-2AtHKT1;1prom* was incubated with *pKGWFS7* [42] in an LR reaction (Invitrogen) to create the *pKGWFS7+AtHKT1;1prom* construct. All constructs were sequenced prior to the transformation of *Arabidopsis* plants. All primers used are listed below in Table 1. All constructs were introduced into *Agrobacterium tumefaciens* strain *GV3101pMP90*, including the *pHGW* empty vector, and transformed into 3-week old *athkt1-1* mutant plants, except *pKGWFS7+AtHKT1;1prom* and the *pKGWFS7* empty vector, which were transformed into 3-week old *Arabidopsis* WT plants. Plant transformation was performed by the flower dipping method [43]. *athkt1;1* mutant plants (N6531) [22] were transformed with *pHGW+AtHKT1;1prom+AtHKT1;1* or *pHGW+AtHKT1;1prom+AtHKT1;1-S68G* or *pHGW+AtHKT1;1prom+SIHKT1;2* or *pHGW+AtHKT1;1prom+SIHKT1;2-S70G*, or *pHGW+AtHKT1;1prom+SIHKT1;2-S70G;K477Q*, or *pHGW+AtHKT1;1prom+SIHKT1;1*. The *pHGW* vector carries a hygromycin resistance gene conferring hygromycin resistance to all transformed plants. *Arabidopsis* WT plants were transformed with *pKGWFS7+AtHKT1;1prom* or *pKGWFS7* empty vector. The *pKGWFS7* vector carries a kanamycin resistance gene conferring kanamycin resistance to all transformed plants. Four weeks after transformation, seeds were harvested and surface sterilized. Surface sterilization was performed by washing seeds during 1 min with a 80% ethanol solution + 0.1% Tween-20, followed by a 20 minutes washing step with 1% commercial bleach, and three washing steps with sterile MilliQ. MilliQ was then replaced by warm half-strength Murashige and Skoog (MS) medium supplemented with 1% sucrose, 0.8% agar and 10 mg/L hygromycin or 50 mg/L kanamycin. Seeds were placed in round plates containing solid MS medium with the same composition. Seedlings showing hygromycin or kanamycin resistance were selected and transferred to pots containing a mix of soil and peat (1:1). They were grown for 4 weeks under the growing conditions, described in the *Plant Material and growth conditions* section, after which the seeds were harvested. T2 seeds were tested for kanamycin or hygromycin resistance and used to investigate their growth response under different NaCl concentrations.

Table 1: List of primers used to amplify both *AtHKT1;1* and *SIHKT1;2* promoters and *AtHKT1;1*, *AtHKT1;1-S68G*, *SIHKT1;2*, *SIHKT1;2-S70G*, *SIHKT1;2-S70G;K477Q* and *SIHKT1;1* genes with the *attB* Gateway recombination sites.

Gene/ Promoter	Primer name	Primer sequence (5' to 3')
AtHKT1;1 promotor	AtHKT1;1 prom (attB1)	GGGGACAAGTTTGTACAAAAAAGCAGGCTGCA AGTGATTGATACTCAGTTAAAAAGTTTCATCAA GC
	AtHKT1;1 prom (attB5r)	GGGGACAAC TTTTGTATACAAAGTTGTTTTAGT TCTCGAGTCGGTTTAAGCATTA
	AtHKT1;1 prom (attB2)	GGGGACCACTTTGTACAAGAAAGCTGGGTATT TAGTTCTCGAGTCGGTTTAAGCATTA
AtHKT1;1 gene	AtHKT1;1 (attB5)	GGGGACAAC TTTTGTATACAAAGTTGATGGAC AGAGTGGTGGCA
	AtHKT1;1 (attB2)	GGGGACCACTTTGTACAAGAAAGCTGGGTATT AGGAAGACGAGGGGTA
SIHKT1;2 gene	SIHKT1;2 (attB5)	GGGGACAAC TTTTGTATACAAAGTTGATGAAG TCATCACTTTCA
	SIHKT1;2 (attB2)	GGGGACCACTTTGTACAAGAAAGCTGGGTATT ATAATACTTTCCAAGCC
SIHKT1;1 gene	SIHKT1;1 (attB5)	GGGGACAAC TTTTGTATACAAAGTTGATGAGT AGCTTATCTTAT
	SIHKT1;1 (attB2)	GGGGACCACTTTGTACAAGAAAGCTGGGTACA AGAGCTTCCAAGCTTCC

Analysis of transcripts levels

Tissue specific expression of all *HKT* genes was tested by extracting total RNA from roots and leaves of three-week old WT and transformed *Arabidopsis* lines. RNA extraction, cDNA production and Q-PCR were performed as described in Chapter 4. β -*Actin* transcript levels were used as an internal standard. The full list of primers used is shown in Table 2.

Table 2: Sequences of gene specific primer pairs used in Q-RT-PCR experiments.

Primer name	Primer sequence (5' to 3')
<i>AtHKT1;1</i>	Fw <i>AtHKT1 F1</i> TATGGGTTTGCAGGACGATGGAGT
<i>AtHKT1;1-S68G</i>	Rv <i>AtHKT1 R1</i> GCCAGATTTGGCTGTGAACTGCTT
<i>SIHKT1;2</i>	Fw <i>SIHKT1 F12</i> TTGGAGTGGAAATTCTGAAG
<i>SIHKT1;2-S70G</i>	Rv <i>SIHKT1 R7</i> CCAGCATGCCTTGTATTAC
<i>SIHKT1;2-S70G;K477Q</i>	
<i>SIHKT1;1</i>	Fw <i>SIHKT2 F8</i> CACAAAAGTGGGGGTATGGT
	Rv <i>SIHKT2 R4</i> TCAGATAACTCCGTCCACCA
<i>Slβ-Actine</i>	Fw <i>Slβ-actine F</i> AAAAGTGCAGTGTCTGTCT
	Rv <i>Slβ-actine R</i> TCAAAAAACAAATTGACTGG

Statistical analyses of data

Two-way ANOVA was used to assess the effect of salt treatment on *HKT1* gene expression, fresh weight, Na⁺ and K⁺ accumulation. Data were rank-transformed if normality or homogeneity assumptions were violated. If ANOVA was significant, a *post hoc* test (Tukey's

test) was used to evaluate differences among treatment and plant lines. All tests were performed using SPSS 17.0.

Results

Characterization of *Arabidopsis athkt1;1* and Col-0 WT plants

Before we performed the transformation of *Arabidopsis thaliana* plants, the *athkt1;1* mutant plants (N6531) were tested for their salinity tolerance, *AtHKT1;1* expression and the presence of the T-DNA insert in the *AtHKT1;1* gene [22]. Figure 1 shows the difference in size obtained between *athkt1;1* (N6531) mutant plants and wild type *Arabidopsis* plants when treated with NaCl. Interestingly, the salt sensitive phenotype of *athkt1;1* mutant plants is displayed sooner and requires lower concentrations of NaCl when plants are grown in hydroponics (Fig. 1A) than grown on soil (Fig. 1B). N6531 plants have the T-DNA insert in the *AtHKT1;1* gene in both roots and shoots (Fig. 1C) and did not express *AtHKT1;1* (Fig. 1D).

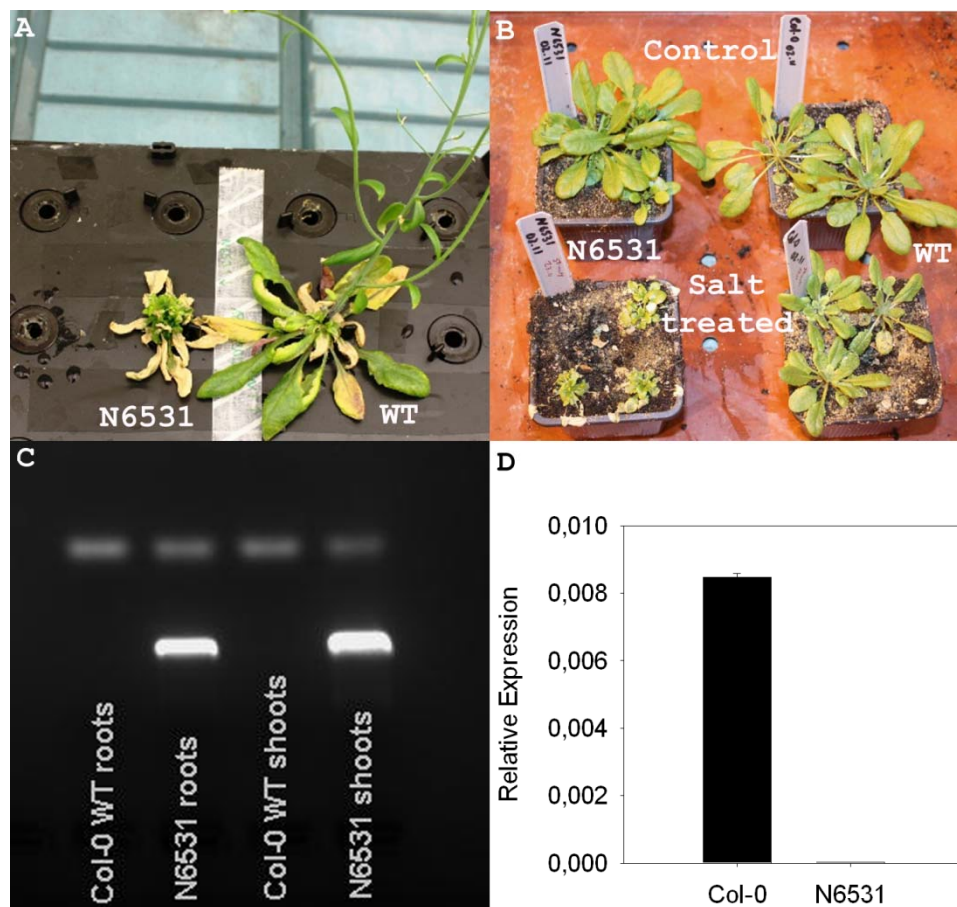

Figure 1: *athkt1;1* mutant plants show reduced resistance to salinity stress. Four weeks old *Arabidopsis thaliana* plants grown on (A) hydroponics were treated for three weeks with 50 mM NaCl, and (B) on soil were treated with 100 mM NaCl for five weeks. (C) The presence of the T-DNA insert in the *HKT1;1* gene of *A. thaliana athkt1;1* (N6531) mutant plants was confirmed by a PCR reaction according to Rus et al. [22]. (D) Expression of *AtHKT1;1* was measured in root tissue of Col-0 WT and *athkt1;1* (N6531) mutant plants by real-time PCR.

Selection and molecular analysis of T2 plants

T2 *Arabidopsis* plantlets carrying the SIHKT1;2 or SIHKT1;1 or AtHKT1;1 or SIHKT1;2-S70G or AtHKT1;1-S68G or SIHKT1;2-S70G;K477Q (as described in Materials and methods) showing antibiotic resistance were selected and their *HKT1* gene expression analysed. All genes were expressed under the AtHKT1;1 endogenous promoter. In this study we used a 5kb long DNA sequence as described by Baek et al. [27]. This promoter contains both R1 and R2 repeats involved in the regulation of AtHKT1;1 expression [27]. To our knowledge this complementation study was the first using an *AtHKT1;1* promoter containing these two repeats. The presence of both R1 and R2 repeats in this promoter is assumed to allow a more natural regulation of *HKT1* expression than the expression regulated by shorter fragments of this promoter.

All lines tested showed *HKT1* expression levels higher than the N6531 mutant plants. Per construct three lines showing *HKT1* expression levels similar to wild type plants were selected (Fig. 2). Expression of *AtHKT1;1* was not detected in *athkt1;1* mutant plants.

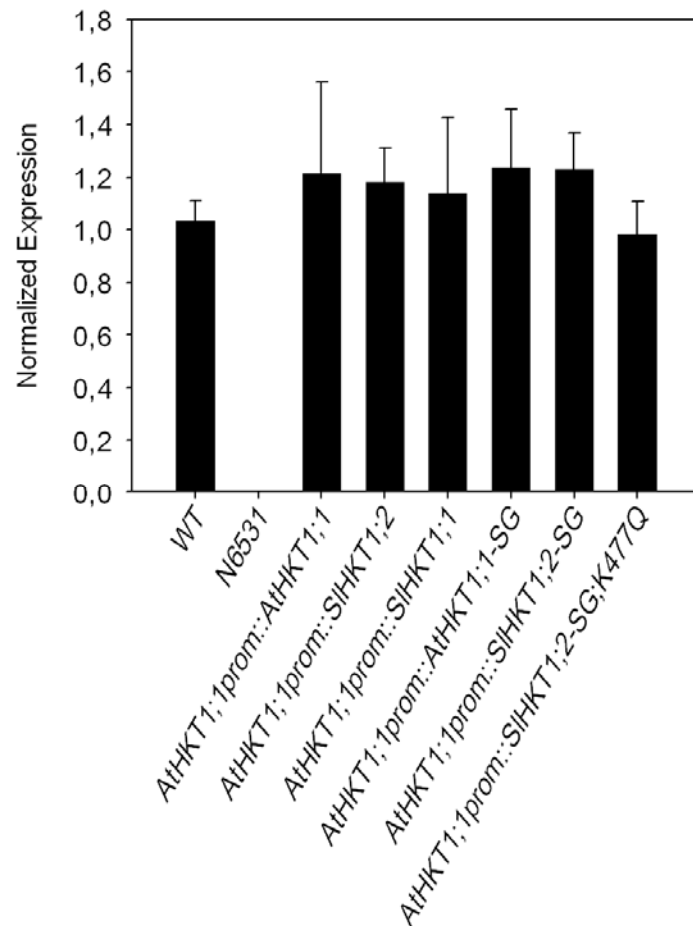

Figure 2: *athkt1;1* plants transformed with *AtHKT1;1prom::AtHKT1;1*, *AtHKT1;1prom::SIHKT1;2*, *AtHKT1;1prom::SIHKT1;1*, *AtHKT1;1prom::AtHKT1;1-S68G*, *AtHKT1;1prom::SIHKT1;2-S70G* and *AtHKT1;1prom::SIHKT1;2-S70G;K477Q* using Col-0 wild-type (WT) and *athkt1;1* (N6531) *Arabidopsis thaliana* plants as positive and negative controls, respectively. Expression was measured in T2 plants. Values are means±SE. of 3-4 replicates. Differences in gene expression are not statistically significant.

GUS expression in *A. thaliana* under the *A. thaliana* *HKT1;1*

To test whether the 5 kb promoter of *AtHKT1;1* was active in the vasculature, like previously reported for a shorter promoter fragment [18] we analysed *Arabidopsis* transgenic plants expressing the *AtHKT1;1prom::GUS* construct (Fig. 3). The 5 kb *AtHKT1;1* promoter fragment was able to drive the expression of *GUS* in the vascular tissues of transformed *Arabidopsis* wild type plants. *GUS* activity driven by *AtHKT1;1* promoter was only observed in the vascular tissues of leaves of transgenic *Arabidopsis* plants (Fig. 3A and 3B). Although *AtHKT1;1* is expressed in the roots [16,18,24,44,45], we were not able to see *GUS* activity in

the roots of transformed *Arabidopsis* plants. Also Sunarpi et al. [18] could only show a very faint GUS staining in the roots of transformed *Arabidopsis* plants.

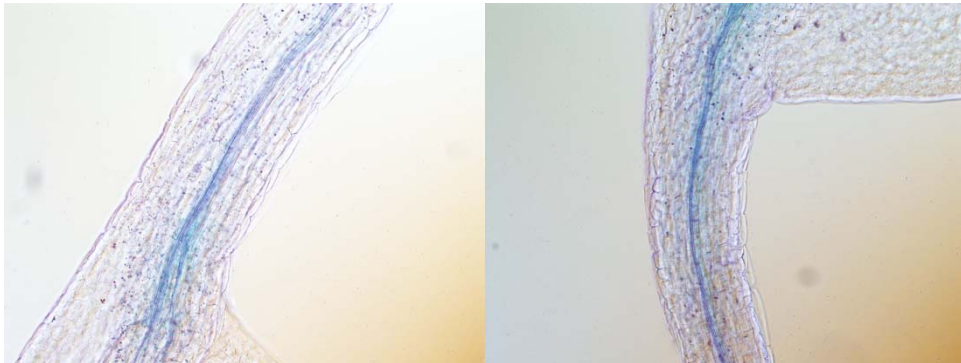

Figure 3: Detection of GUS activity in the vascular system of transgenic *Arabidopsis thaliana* plants. *Arabidopsis* plants expressing the *GUS* gene under the control of the *AtHKT1;1* promoter (both photos) were grown on 0.5 MS medium containing 0.8% agar and 1% sucrose. Strong blue GUS staining was detected in the vicinity of the xylem and phloem in leaves (both photos).

Analysis of FW, Na⁺ and K⁺ accumulation of transgenic *Arabidopsis* lines

As described in Chapter 5, there was a marked difference in K⁺-sensitivity of Na⁺-transport mediated by the *AtHKT1;1* and *SIHKT1;2* proteins, as analysed in *Xenopus laevis* oocytes. To see whether this difference was reflected in Na⁺/K⁺ homeostasis *in planta*, we expressed the *AtHKT1;1* and *SIHKT1;2* genes driven by a 5 kb long *AtHKT1;1* promoter in the *athkt1;1* mutant plants and studied how they complemented the mutant phenotype. Since the analysis of *SIHKT1;2* mutated genes in *Xenopus* oocytes (presented in Chapter 5) showed interesting effects on transport activity and ion selectivity we transformed *athkt1;1* plants with some of the *SIHKT1;2* mutated genes (*SIHKT1;2*-S70G and *SIHKT1;2*-S70G-K477Q) and *AtHKT1;1*-S68G as well and tested the effect of these mutated proteins *in planta* during salinity stress. Recently, we also identified a homologue of *SIHKT1;2*, namely *SIHKT1;1* (see Fig. S1 for an alignment of *SIHKT1;2* and *SIHKT1;1*) (also identified by Asins et al. [46]) and we took this gene along in our complementation assay, even though we were not able to show any transport activity when we expressed this gene in oocytes (unpublished. data).

Fig. 4 shows the effect of salinity treatment on the leaf fresh weight of wild type, *athkt1;1* and transgenic plants. The salt stress applied was rather mild, but clearly the *athkt1;1* mutant plants were more sensitive to salt than the WT plants. Both the *AtHKT1;1* and the *SIHKT1;2*

gene, but not the *SIHKT1;1* gene, were able to complement the *athkt1;1* mutant growth phenotype on salt (Fig. 4). All plants transformed with the mutated *HKT1* genes were just as sensitive to salt as the *athkt1;1* mutant plants. From this we conclude that complementation of the *athkt1;1* plants with HKT transporters that are able to transport K^+ (albeit at low rate) do not alleviate the salt sensitive growth phenotype. We also measured the relative water content of the leaves, and these results did not show statistically significant differences between control and salt treated plants (data not shown) nor within transformed lines.

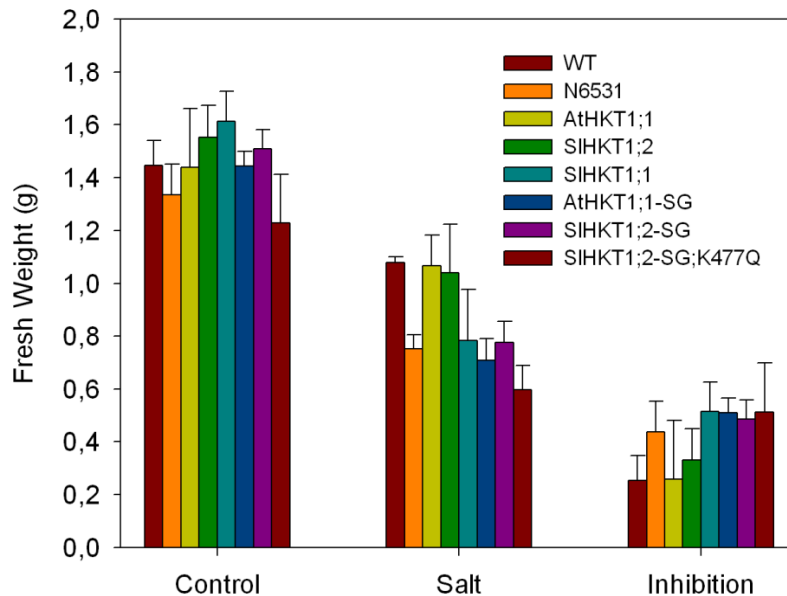

Figure 4: Presence of 100 mM NaCl in the irrigation water during two weeks significantly reduced the fresh weight of transformed, wild type and *athkt1;1* *Arabidopsis* plants in comparison to control plants irrigated with water not supplemented with NaCl. Different inhibitions on the fresh weight production are observed amongst different transformed plant lines. *Arabidopsis* wild type and *athkt1;1* plants were used as positive and negative controls, respectively. Treatment: $p < 0.05$; plant lines: n.s.; treatment*plant lines (n.s.); two-way ANOVA. Values indicate the means \pm SE of three to seven biological replicas.

Although the effect of the *AtHKT1;1* mutation on growth during salt stress was not that strong (Fig. 4), the effect on Na^+ and K^+ homeostasis was more pronounced (Fig. 5). The *athkt1;1* plants accumulated almost 4-fold more Na^+ and two-fold less K^+ , resulting in an 8-fold higher Na^+/K^+ ratio in the shoot of the mutant plants as compared to the wild-type plants. The transgenic lines that complemented the *athkt1;1* growth phenotype (*AtHKT1;1* and *SIHKT1;2*) showed interesting effects on ion accumulation: the *athkt1;1* K^+ -phenotype during salt stress (i.e. strong reduction in K^+ accumulation) was completely restored, but Na^+

accumulation in the leaves of these transgenic lines was still significantly higher than that of WT-plants. Apparently, the relatively high Na^+/K^+ ratio in the leaves of these plants (around 1.5 versus 0.6 in WT plants) had no negative effect on shoot growth (Fig. 4). It was disappointing to see that the other transgenic lines with the mutated *HKT1* genes were indistinguishable from the *athkt1;1* mutant plants as far as Na^+ and K^+ homeostasis goes. Since the SIHKT1;2-S70G-K477Q protein showed both Na^+ and K^+ transport activity in *Xenopus* oocytes (Chapter 5), we expected to see this property reflected in the accumulation of Na^+ and K^+ in the shoot of this line.

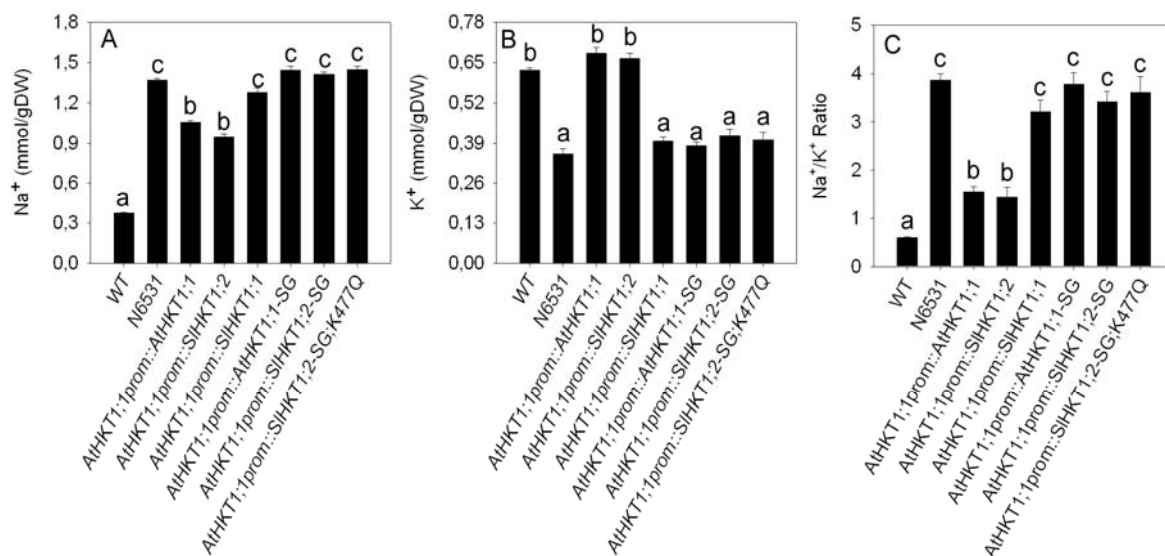

Figure 5: Na^+ (A) and K^+ (B) accumulation and Na^+/K^+ (C) ratio in the shoot of WT, *athkt1;1* mutant (N6531) and transgenic lines expressing different *HKT1* genes. The effect of the mutation in the *AtHKT1;1* gene is very clear, showing a strong increase in shoot Na^+ , accompanied by a decrease in K^+ which results in a very strong increase in the Na^+/K^+ ratio. Both lines expressing *AtHKT1;1* or *SIHKT1;2* were able to reduce the accumulation of Na^+ and increase the accumulation of K^+ in comparison to *athkt1;1*. The other lines expressing *SIHKT1;1* or any of the mutated genes were not able to ameliorate the phenotype of the *athkt1;1* plants. Different letters above bars indicate statistically significant differences. Values indicate the means \pm SE of three to seven biological replicas.

Discussion

The complementation of plant mutant phenotypes with wild-type genes, or mutant versions thereof is a widely used strategy to study the function of specific transporters *in planta*. Detailed information about molecular characteristics of transporters can be obtained through expression in heterologous systems like *Xenopus* oocytes or yeast cells, but a key question is

whether the characteristics as observed in the heterologous expression systems are also reflected in the physiology of transgenic plants expressing the particular gene or mutant version, as discussed by Haro et al. [41]. In the previous two Chapters we studied the transport characteristics of AtHKT1;1 and SIHKT1;2 as well as several mutated versions of SIHKT1;2 expressed in *Xenopus laevis* oocytes. In this Chapter we complemented *athkt1;1* plants with the following genes *AtHKT1;1*, *SIHKT1;2*, *AtHKT1;1S68G*, *SIHKT1;2S70G* and *SIHKT1;2S70G-K477Q* and we studied their functioning *in planta* under salinity stress. Notable differences measured in the oocytes were i) reduction of Na⁺-currents by K⁺ with SIHKT1;2, and not with AtHKT1;1, ii) K⁺-transport instead of Na⁺-transport by AtHKT1;1-S68G and iii) both Na⁺ and K⁺-transport by SIHKT1;2-S70G and SIHKT1;2-S70G-K477Q.

***AtHKT1;1* and *SIHKT1;2* expressing lines**

All plants showed a reduction in fresh weight caused by the salt treatment and as expected, the salt-induced growth reduction was stronger in the *athkt1;1* mutant plants than in wild-type plants. With respect to growth on salt, *AtHKT1;1* and *SIHKT1;2* expression complemented the mutant, since the fresh weight of these lines was comparable to that of wild-type plants treated with salt (Fig. 4) Although expression of *AtHKT1;1* and *SIHKT1;2* completely restored the concentration of K⁺ in the shoot to the level of the wild-type plants, Na⁺ levels were still higher. Both *AtHKT1;1* and *SIHKT1;2* expressing lines accumulated significantly less Na⁺ than the other transgenic lines, but significantly more Na⁺ than the wild type plants. This indicates that in these two transgenic lines both *HKT1* genes do not retrieve the same amount of Na⁺ from the xylem as wild-type plants. This difference in Na⁺ accumulation in lines expressing *AtHKT1;1* and *SIHKT1;2* in comparison to wild-type plants is surprising. In this study we used the native *AtHKT1;1* promoter [27] to drive the expression of all genes studied, avoiding non-native promoters as these are frequently referred to as the cause of unexpected results [47]. The expression of *GUS* driven by the native *AtHKT1;1* promoter (Fig. 1) showed that the expression patterns were similar to previous results [18] and also the level of *HKT*-expression in the different transgenic lines was comparable to that in wild-type plants (Fig. 2). Another observation of interest is that Na⁺ accumulation in the shoots of *SIHKT1;2* expressing lines is slightly lower than that in shoots of *AtHKT1;1* expressing lines (Fig. 5). Transport characteristics of the *AtHKT1;1* and *SIHKT1;2* expressed in *Xenopus* oocytes differed in two ways: SIHKT1;2 but not AtHKT1;1, showed an allosteric inhibition of Na⁺ transport by K⁺ and the total Na⁺ mediated current (i.e. the turn-over) measured in SIHKT1;2 expressing oocytes was considerably higher than that in AtHKT1;1 expressing

oocytes (Fig. 8, Ch. 5). The latter conclusion needs further testing since it is based on the assumption that injection of the same amount of cRNA results in the same amount of protein expressed in the plasma membrane. So, it is too early to conclude whether the allosteric effect of K^+ on Na^+ transport by *SIHKT1;2* has physiological significance *in planta*. However, it is clear that in these two transgenic lines, both HKT1 transporters are involved in the retrieval of Na^+ ions from the xylem, as previously demonstrated for HKT1 transporters from several species [3,9,12-14,16,19,20,26,27,40,48-50].

As shown in Fig. 5, mutating the *athkt1;1* gene not only results in an increase in shoot Na^+ concentration, but also in a strong reduction in shoot K^+ levels. This effect on K^+ -accumulation has been reported before [17,51], but a good explanation for this effect is missing thus far. Moller et al. [19] reported that the increase in K^+ concentration in the shoots from plants over-expressing *AtHKT1;1*, was a pleiotropic effect and a consequence of the reduced Na^+ shoot content. Another explanation given is that the uptake of Na^+ from the xylem into the XPCs via HKT1 results in the depolarization of the membrane potential of XPCs and activation of the depolarization activated K^+ efflux channel SKOR, resulting in more K^+ release into the xylem [18]. A third explanation is that *AtHKT1;1* functionally interacts with a K^+ -efflux transporter in the plasma membrane of XPCs. Support for this hypothesis is found in a recently published large scale membrane interaction screen based on a yeast mating split-ubiquitin system (mbSUS) (Membrane-based Interactome Network Database, MIND: <http://cas-biodb.cas.unt.edu/project/mind/index.php>). In this screen, *AtHKT1;1* was reported to interact with KEA3, a putative K^+ -efflux antiporter and member of the Proton Antiporter-2 (CPA2) family. If this can be confirmed *in planta*, then this may provide an explanation for the K^+ -phenotype of the *athkt1;1* mutant: the absence of the *AtHKT1;1* protein in the plasma membrane of xylem parenchyma cells (XPCs) may have a negative effect on the KEA3 antiporter, resulting in reduced root to shoot K^+ -transport. These hypotheses are certainly worth testing in view of the importance of Na^+/K^+ homeostasis during salinity stress.

Complementation of the *athkt1;1* mutant with the *AtHKT1;1* and *SIHKT1;2* genes indeed fully restored the K^+ -content in the shoots (Fig. 5) to a level that slightly exceeds that of the wild-type plants. So, with respect to restoring the net K^+ -flux to the shoot the *Arabidopsis* and tomato HKT proteins act in a similar manner.

With respect to the *SIHKT1;1* expressing line, the lack of complementation was not unexpected, since we could not measure any currents when *SIHKT1;1* was expressed in *Xenopus* oocytes (data not shown). This is in contrast to the results published by Asins et al.

[46], where they reported that yeast cells expressing *SIHKT1;1* were able to deplete Na^+ from the growth medium.

Lines expressing *HKT*-mutant genes

Unlike the *AtHKT1;1* and *SIHKT1;2* expressing lines, the remaining transgenic lines were comparable with the *athkt1;1* mutant plants with respect to growth and Na^+/K^+ accumulation when exposed to salt. So, none of the introduced genes was able to complement the *athkt1;1* mutation. Although overall, the introduced mutations did result in a strong reduction of the total transport capacity in oocytes, Na^+ and K^+ currents mediated by the *AtHKT1;1*-S68G and *SIHKT1;2*-S70G-K477Q proteins are still significant as measured in the oocyte system (Figs. 8 and 9 Ch. 5). Nevertheless, *in planta*, this remaining transport capacity did not alter the shoot Na^+ and K^+ accumulation in comparison to that in the *athkt1;1* mutant plants. We did grow the plants used in this experiment on soil since we favoured a more or less natural root environment. However, Na^+ and K^+ concentrations in the soil water are difficult to control and it may well be that phenotypic effects of these transgenic lines become manifest when plants are grown on Hoagland solutions with defined and different Na^+ and K^+ concentration in the solution.

Besides the lack of restoring low shoot Na^+ accumulation, also the reduction of shoot K^+ in the *athkt1;1* mutant background was not restored. This is a meaningful observation with respect to the above given hypotheses on why the *athkt1;1* mutation also affects K^+ -homeostasis (Fig. 6). If the HKT1 protein controls the efflux of K^+ to the xylem through direct interaction with the KEA3 antiporter, then it seems unlikely that a point mutation in the first pore domain or the $\text{M}_{2\text{D}}$ domain would disrupt the HKT/KEA3 interaction. Therefore, it seems more likely that the HKT protein has to be functional with respect to Na^+ transport in order to restore the net K^+ -flux to the shoot. So, the indirect model where HKT1 affects K^+ -loading into the xylem through depolarization activated SKOR channels [52-54], seems more likely than the direct HKT1/KEA3 model.

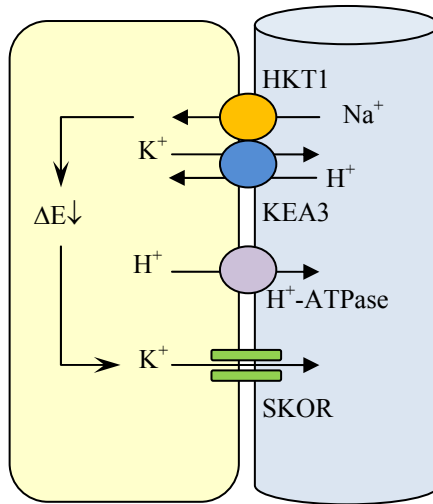

Figure 6: Schematic representation of a model where the HKT1 protein controls the efflux of K^+ to the xylem through direct interaction with the KEA3 antiporter or via the activation of SKOR channels [52-54] resultant from the depolarization caused by Na^+ uptake from the xylem.

In conclusion, when expressed under the *AtHKT1;1* native promoter, both *AtHKT1;1* from *Arabidopsis thaliana* and *SlHKT1;2* from *Solanum lycopersicum* partially complement the Na^+ accumulation phenotype and fully complement the K^+ accumulation phenotype of *athkt1;1* mutant plants. *AtHKT1;1-S68G*, *SlHKT1;2-S70G*, *SlHKT1;2-K477Q* and *SlHKT1;1* were unable to complement either the Na^+ or the K^+ phenotype of *athkt1;1* mutant plants. The latter is an indication that the role of HKT1 in K^+ -homeostasis is coupled to HKT1 mediated Na^+ transport rather than to the direct interaction of HKT proteins with K^+ -transport proteins in the same membrane. The transport activity of mutated HKT proteins as measured in *Xenopus* oocytes, was not reflected in altered Na^+/K^+ homeostasis of the *athkt1;1* mutants grown under soil conditions.

Supplemental results

	10	20	30	40	50	60
SlHKT12	-----	-----	MKSSLSISFFKIMMSLRVKPFWIELGYFTTLLSLL			
SlHKT11	MSSLSYLGEKQLQHLFSSIFLYVSVCLCGSTCFLISSLYRSILFKVKNKFFIQLFYFIFISIF					
Consensus			gkscllISflkrmillrVnkFfi#LgYFifiSil			
Prim.cons.	MSSLSYLGEKQLQHLFSSIFLYVSVCLC222222IS222222222V22F2I2L2YF222S22					
	70	80	90	100	110	120
SlHKT12	GFLALNYSKPRTLPSFRPQNLDVLFSTVSSSTTVSSMSTIEMEVSNSVQLVFMFILMFLG					
SlHKT11	GFLILRNLN-PRHSEDFSTNLDLFFTSVSSATISSMSTIEMEVSNSQLVITFLMFI					
Consensus	GFLaLrnlN PRhledFrpqNLDl1FFTSVSSaT!SSMSTIEMEVSNSQL!fiTiLMFI					
Prim.cons.	GFL2L2222KPR2222F222NLD22FTSVSS2T2SSMST2EMEVSNS2QL222T2LMF2G					
	130	140	150	160	170	180
SlHKT12	GEAFTSFLSPKLIK-----NKEskDKSF-----SNKDYELGNVINVDNKLEDVVI					
SlHKT11	GEVFISMIELYLIRPKFKPWRKNSKIEsILSSNNSTTSsPRNSNFNDDDYNIELDIVVL					
Consensus	GEaFiSmieLkLIr rK#SKdeSi Snr#s#lnNdd#y#neL#dV!i					
Prim.cons.	GE2F2S22222LI2PKFKPW2K2SK22S2LSSNNSTTS222222N222222L22V22					
	190	200	210	220	230	240
SlHKT12	INPIEDHIHDH-----DEIKIKSIKLLSNVVFYILVVILLGSSLVSLYIIIPSA					
SlHKT11	PDSPKSIKSDKDKDDFTSSDNNLKYQSIKFLGVVTLVYLLVINIVGMSLVLMYLAFVSSA					
Consensus	i#piedhihDhd D#niKiqSIKlLgnVtlgYiLV!nilGmSLVl\$Yiai!pSA					
Prim.cons.	222222222D22KDDFTSSD222K22SIK2L22V222Y2LV2222G2SLV22Y22222SA					
	250	260	270	280	290	300
SlHKT12	KQILDQKGLNLHTFSLFTTVSTFANCGFLPTNENMMIFKKNsGLLLILIPQVLLGNLTLFA					
SlHKT11	KDVLINKGLNTYIFTIFTTISsFVSCGFVPTNENMMVFSKNsGLLWILIPLLLGNALYP					
Consensus	K#!Ld#KGLNlhiFsiFTT!SsFanCGFlPTNENMM!FkKNsGLLlILIPqllLlGNal&a					
Prim.cons.	K22L22KGLN222F22FTT2S2F22CGF2PTNENMM2F2KNsGLL2ILIP22L2GN2L22					
	310	320	330	340	350	360
SlHKT12	PCLRIVIMFLWK--ITKRHEYEYILKNSKCVGYSHIFPSYETIGIAITVVGLIVFQFVMF					
SlHKT11	MCLRFsIRLMGKLfVSKKREAKYLLKNSREIGHLHLFSRQHSRLLVVTMFGLILVQFILF					
Consensus	mCLRisIrl\$gK !sKrrEaeYiLKNSrc!GhlHiFprqesrgia!TmfGIlfQF!\$F					
Prim.cons.	2CLR22I2222KLF22K22E22Y2LKNS222G22H2F222222222T22G2I22QF22F					
	370	380	390	400	410	420
SlHKT12	CSLEWNSegTSGLSTYEKIvGSLFEVVNTRHAGLSVFDLSTFTPSILVLFALMM-----					
SlHKT11	CALEWNSNGLNGLNSYQRFVGSFLQVVNARHTGETIVDIStLSPpILVMFIVMMAKTLIV					
Consensus	CaLEWNS#GlnGLnsY#riVGSFL#VVNaRHaGes!fDiStLsPpILV\$FalMM					
Prim.cons.	C2LEWNS2G22GL22Y222VGSLF2VVN2RH2G2222D2ST22P2ILV2F22MMAKTLIV					
	430	440	450	460	470	480
SlHKT12	-----YLSSYTTFLPVDNYEEKSEKM---KRRKGRSLMEYISLSQPcCLVIFtILICVVE					
SlHKT11	SLFFRYLPPYTSFIPVKGVEENTEeEYLFGEKQKRGKVVENFIFSQLCYLSLFIvLICITE					
Consensus	YLppYTsFiPvdnyEEnsEem eKrKrrklmEniilSQLCcLsiFi!LIC!tE					
Prim.cons.	SLFFRYL22YT2F2PV222EE22E22LFG2K2K22222E2222SQ2C2L22F22LIC22E					

	490	500	510	520	530	540
SlHKT12	KDKMKNDPLNFNVLNILEVISAYGTVGLSIGYSCARQINPDGHCKDVTYGFAGKWSNTG					
SlHKT11	RKKMKDDPLNFNVLNITLEVISAYGNVGF TTYGYS CDRM INGDQSCKNKWYGFVGKWSDEG					
Consensus	rDKMK#DPLNFNVLNIlLEVISAYGnVGLsiGYSCaRqINgDqhCK#ktYGFaGKWS#eG					
Prim.cons.	22KMK2DPLNFNVLNI22EVISAYG2VG222GYSC2R2IN2D22CK222YGF2GKWS22G					
	550	560				
SlHKT12	KFILIIVMFFGRS KKY NQRGGKAWKVL					
SlHKT11	KIIIIIMFFGR LKKFNMQGGKAWKLL					
Consensus	KiIIII!MFFGRlKK%NqrGGKAWKlL					
Prim.cons.	K2I2II2MFFGR2KK2N22GGKAWK2L					

Figure S1: Alignment of amino acid sequences of *Solanum lycopersicum* *SlHKT1;2* and *SlHKT1;1*. Amino acid sequences were deduced from nucleotide sequences of cDNA. Alignment performed using NPS: Network Sequence Analysis http://npsa-pbil.ibcp.fr/cgi-bin/align_multalin.pl.

References

- Munns R, Tester M (2008) Mechanisms of salinity tolerance. *Annual Review of Plant Biology* 59: 651-681.
- FAO (2009) FAO land and plant nutrition management service. www.fao.org/ag/agl/agll/spush/
- Plett D, Safwat G, Gilliam M, Moller IS, Roy S, et al. (2010) Improved salinity tolerance of rice through cell type-specific expression of *AtHKT1;1*. *PloS One* 5.
- Tholema N, Bakker EP, Suzuki A, Nakamura T (1999) Change to alanine of one out of four selectivity filter glycines in KtrB causes a two orders of magnitude decrease in the affinities for both K⁺ and Na⁺ of the Na⁺ dependent K⁺ uptake system KtrAB from *Vibrio alginolyticus*. *FEBS Letters* 450: 217-220.
- Rodriguez-Navarro A (2000) Potassium transport in fungi and plants. *Biochimica et Biophysica Acta* 1469: 1-30.
- Maser P, Hosoo Y, Goshima S, Horie T, Eckelman B, et al. (2002) Glycine residues in potassium channel-like selectivity filters determine potassium selectivity in four-loop-per-subunit HKT transporters from plants. *Proceedings of the National Academy of Sciences of the United States of America* 99: 6428-6433.
- Platten JD, Cotsaftis O, Berthomieu P, Bohnert H, Davenport RJ, et al. (2006) Nomenclature for HKT transporters, key determinants of plant salinity tolerance. *Trends in Plant Science* 11: 372-374.
- Byrt CS, Platten JD, Spielmeier W, James RA, Lagudah ES, et al. (2007) HKT1;5-like cation transporters linked to Na⁺ exclusion loci in wheat, *Nax2* and *Kna1*. *Plant Physiology* 143: 1918-1928.
- Munns R., James RA, Xu B, Athman A, Conn JS, et al. (2012) Wheat grain yield on saline soils is improved by an ancestral Na⁺ transporter gene. *Nature Biotechnology* 30: 360-364.
- James RA, Davenport R. J., R. M (2006) Physiological characterisation of two genes for Na⁺ exclusion in durum wheat: *Nax1* and *Nax2*. *Plant Physiology* 142: 1537-1547.
- Davenport R. J., James RA, Zakrisson-Plogander A, Tester M, R. M (2005) Control of sodium transport in durum wheat. *Plant Physiology* 137: 807-818.
- Ren ZH, Gao JP, Li LG, Cai XL, Huang W, et al. (2005) A rice quantitative trait locus for salt tolerance encodes a sodium transporter. *Nature Genetics* 37: 1141-1146.

13. Jabnoue M, Espeout S, Mieulet D, Fizames C, Verdeil JL, et al. (2009) Diversity in expression patterns and functional properties in the rice HKT transporter family. *Plant Physiology* 150: 1955-1971.
14. Horie T, Costa A, Kim TH, Han MJ, Horie R, et al. (2007) Rice OsHKT2;1 transporter mediates large Na⁺ influx components into K⁺-starved roots for growth. *The EMBO Journal* 26: 3003-3014.
15. Uozumi N, Kim EJ, Rubio F, Yamaguchi T, Muto S, et al. (2000) The *Arabidopsis* *HKT1* gene homolog mediates inward Na⁺ currents in *Xenopus laevis* oocytes and Na⁺ uptake in *Saccharomyces cerevisiae*. *Plant Physiology* 122: 1249-1259.
16. Berthomieu P, Conejero G, Nublat A, Brackenbury WJ, Lambert C, et al. (2003) Functional analysis of *AtHKT1* in *Arabidopsis* shows that Na⁺ recirculation by the phloem is crucial for salt tolerance. *EMBO Journal* 22: 2004-2014.
17. Rus A, Lee BH, Munoz-Mayor A, Sharkhuu A, Miura K, et al. (2004) *AtHKT1* facilitates Na⁺ homeostasis and K⁺ nutrition *in planta*. *Plant Physiology* 136: 2500-2511.
18. Sunarpi, Horie T, Motoda J, Kubo M, Yang H, et al. (2005) Enhanced salt tolerance mediated by *AtHKT1* transporter-induced Na⁺ unloading from xylem vessels to xylem parenchyma cells. *Plant Journal* 44: 928-938.
19. Moller IS, Gilliam M, Jha D, Mayo GM, Roy SJ, et al. (2009) Shoot Na⁺ exclusion and increased salinity tolerance engineered by cell type-specific alteration of Na⁺ transport in *Arabidopsis*. *Plant Cell* 21: 2163-2178.
20. Garciadeblas B, Senn ME, Banuelos MA, Rodriguez-Navarro A (2003) Sodium transport and HKT transporters: the rice model. *Plant Journal* 34: 788-801.
21. Huang SB, Spielmeyer W, Lagudah ES, James RA, Platten JD, et al. (2006) A sodium transporter (HKT7) is a candidate for *Nax1*, a gene for salt tolerance in durum wheat. *Plant Physiology* 142: 1718-1727.
22. Rus A, Yokoi S, Sharkhuu A, Reddy M, Lee BH, et al. (2001) *AtHKT1* is a salt tolerance determinant that controls Na⁺ entry into plant roots. *Proceedings of the National Academy of Sciences of the United States of America* 98: 14150-14155.
23. Maser P, Eckelman B, Vaidyanathan R, Horie T, Fairbairn DJ, et al. (2002) Altered shoot/root Na⁺ distribution and bifurcating salt sensitivity in *Arabidopsis* by genetic disruption of the Na⁺ transporter *AtHKT1;1*. *FEBS Letters* 531: 157-161.
24. Davenport RJ, Munoz-Mayor A, Jha D, Essah PA, Rus A, et al. (2007) The Na⁺ transporter *AtHKT1;1* controls retrieval of Na⁺ from the xylem in *Arabidopsis*. *Plant Cell and Environment* 30: 497-507.
25. Plett DC, Moller IS (2010) Na⁺ transport in glycophytic plants: what we know and would like to know. *Plant Cell and Environment* 33: 612-626.
26. Mian A, Oomen RJ, Isayenkow S, Sentenac H, Maathuis FJ, et al. (2011) Overexpression of a Na⁺ and K⁺-permeable HKT transporter in barley improves salt tolerance. *Plant Journal* 68: 468-479.
27. Baek D, Jiang JF, Chung JS, Wang BS, Chen JP, et al. (2011) Regulated *AtHKT1* gene expression by a distal enhancer element and DNA methylation in the promoter plays an important role in salt tolerance. *Plant and Cell Physiology* 52: 149-161.
28. James RA, Blake C, Byrt CS, Munns R (2011) Major genes for Na⁺ exclusion, *Nax1* and *Nax2* (wheat *HKT1;4* and *HKT1;5*), decrease Na⁺ accumulation in bread wheat leaves under saline and waterlogged conditions. *Journal of Experimental Botany* 62: 2939-2947.
29. Chen HT, He H, Yu DY (2011) Overexpression of a novel soybean gene modulating Na⁺ and K⁺ transport enhances salt tolerance in transgenic tobacco plants. *Physiologia Plantarum* 141: 11-18.
30. Schachtman DP, Schroeder JI (1994) Structure and transport mechanism of a high-affinity potassium uptake transporter from higher-plants. *Nature* 370: 655-658.
31. Fairbairn DJ, Liu WH, Schachtman DP, Gomez-Gallego S, Day SR, et al. (2000) Characterisation of two distinct HKT1-like potassium transporters from *Eucalyptus camaldulensis*. *Plant Molecular Biology* 43: 515-525.

32. Liu WH, Fairbairn DJ, Reid RJ, Schachtman DP (2001) Characterization of two HKT1 homologues from *Eucalyptus camaldulensis* that display intrinsic osmosensing capability. *Plant Physiology* 127: 283-294.
33. Horie T, Yoshida K, Nakayama H, Yamada K, Oiki S, et al. (2001) Two types of HKT transporters with different properties of Na⁺ and K⁺ transport in *Oryza sativa*. *Plant Journal* 27: 129-138.
34. Gollack D, Su H, Quigley F, Kamasani UR, Munoz-Garay C, et al. (2002) Characterization of a HKT-type transporter in rice as a general alkali cation transporter. *Plant Journal* 31: 529-542.
35. Su H, Balderas E, Vera-Estrella R, Gollack D, Quigley F, et al. (2003) Expression of the cation transporter McHKT1 in a halophyte. *Plant Molecular Biology* 52: 967-980.
36. Yao X, Horie T, Xue SW, Leung HY, Katsuhara M, et al. (2010) Differential sodium and potassium transport selectivities of the rice OsHKT2;1 and OsHKT2;2 transporters in plant cells. *Plant Physiology* 152: 341-355.
37. Lan WZ, Wang W, Wang SM, Li LG, Buchanan BB, et al. (2010) A rice high-affinity potassium transporter (HKT) conceals a calcium-permeable cation channel. *Proceedings of the National Academy of Sciences of the United States of America* 107: 7089-7094.
38. Horie T, Brodsky DE, Costa A, Kaneko T, Lo Schiavo F, et al. (2011) K⁺ transport by the OsHKT2;4 transporter from rice with atypical Na⁺ transport properties and competition in permeation of K⁺ over Mg²⁺ and Ca²⁺ ions. *Plant Physiology* 156: 1493-1507.
39. Takahashi R, Liu S, Takano T (2007) Cloning and functional comparison of a high-affinity K⁺ transporter gene *PhaHKT1* of salt-tolerant and salt-sensitive reed plants. *Journal of Experimental Botany* 58: 4387-4395.
40. Ali Z, Park HC, Ali A, Oh D-H, Aman R, et al. (2012) TsHKT1;2, a HKT1 homolog from the extremophile *Arabidopsis* relative *Thellungiella salsuginea*, shows K⁺ specificity in the presence of NaCl. *Plant Physiology* 158: 1463-1474.
41. Haro R, Banelos MA, Senn MAE, Barrero-Gil J, Rodriguez-Navarro A (2005) HKT1 mediates sodium uniport in roots. Pitfalls in the expression of *HKT1* in yeast. *Plant Physiology* 139: 1495-1506.
42. Karimi M, Inze D, Depicker A (2002) GATEWAY vectors for *Agrobacterium*-mediated plant transformation. *Trends in Plant Science* 7: 193-195.
43. Clough SJ, Bent AF (1998) Floral dip: a simplified method for *Agrobacterium*-mediated transformation of *Arabidopsis thaliana*. *Plant Journal* 16: 735-743.
44. Hauser F, Horie T (2010) A conserved primary salt tolerance mechanism mediated by HKT transporters: a mechanism for sodium exclusion and maintenance of high K⁺/Na⁺ ratio in leaves during salinity stress. *Plant Cell and Environment* 33: 552-565.
45. Horie T, Hauser F, Schroeder JI (2009) HKT transporter-mediated salinity resistance mechanisms in *Arabidopsis* and monocot crop plants. *Trends in Plant Science* 14: 660-668.
46. Asins JM, Villalta I, Aly MM, Olias R, Morales PA, et al. (2012) Two closely linked tomato *HKT* coding genes are positional candidates for the major tomato QTL involved in Na⁺/K⁺ homeostasis. *Plant, Cell and Environment* 36: 1171-1191.
47. Cominelli E, Tonelli C (2010) Transgenic crops coping with water scarcity. *New Biotechnology* 27: 473-477.
48. Baxter I, Brazelton JN, Yu DN, Huang YS, Lahner B, et al. (2010) A coastal cline in sodium accumulation in *Arabidopsis thaliana* is driven by natural variation of the sodium transporter AtHKT1;1. *PLoS Genetics* 6.
49. Laurie S, Feeney KA, Maathuis FJM, Heard PJ, Brown SJ, et al. (2002) A role for HKT1 in sodium uptake by wheat roots. *Plant Journal* 32: 139-149.
50. Liu W, Fairbairn DJ, Reid RJ, Schachtman DP (2001) Characterization of two HKT1 homologues from *Eucalyptus camaldulensis* that display intrinsic osmosensing capability. *Plant Physiology* 127: 283-294.
51. Rus AM, Bressan RA, Hasegawa PM (2005) Unraveling salt tolerance in crops. *Nature Genetics* 37: 1029-1030.
52. De Boer AH, Volkov V (2003) Logistics of water and salt transport through the plant: structure and functioning of the xylem. *Plant Cell and Environment* 26: 87-101.

53. Gaymard F, Pilot G, Lacombe B, Bouchez D, Bruneau D, et al. (1998) Identification and disruption of a plant shaker-like outward channel involved in K⁺ release into the xylem sap. *Cell* 94: 647-655.
54. Wegner LH, De Boer AH (1997) Properties of two outward-rectifying channels in root xylem parenchyma cells suggest a role in K⁺ homeostasis and long-distance signaling. *Plant Physiology* 115: 1707-1719.

Chapter 7

HKT transporters – State of the art

Pedro Almeida^{1*}, Diana Katschnig² and Albertus H. de Boer¹

¹Vrije Universiteit Amsterdam, Faculty Earth and Life Sciences, Department of Structural Biology, NL-1081 HV Amsterdam, the Netherlands

²Vrije Universiteit Amsterdam, Faculty Earth and Life Sciences, Systems Ecology, Department of Ecological Science, NL-1081 HV Amsterdam, the Netherlands

*Corresponding author: p.m.fidalgodealmeida@vu.nl

Abstract

The increase in soil salinity poses a serious threat to agricultural yields. Under salinity stress, several Na⁺ transporters play an essential role in Na⁺ tolerance in plants. Amongst all Na⁺ transporters, HKT has been shown to have a crucial role in both mono and dicotyledonous plants in the tolerance to salinity stress. Here we present an overview of the physiological role of HKT transporters in plant Na⁺ homeostasis. HKT regulation and amino acids important to the correct function of HKT transporters are reviewed. The functions of the most recently characterized HKT members from both HKT1 and HKT2 subfamilies are also discussed. Topics that still need to be studied in future research (e.g., HKT regulation) as well as research suggestions (e.g., generation of HKT mutants) are addressed.

Introduction

Amongst abiotic stresses, soil salinity is one of the major factors affecting agriculture and plant productivity [1]. Salinization is urgently becoming more serious as the area of land affected by salinity is constantly increasing due to climate change or irrigation with poor quality water [1-3]. In order to fight the problem of salinity, a better understanding of the physiological mechanisms involved in ion homeostasis in the plant needs to be achieved. Amongst the salts that accumulate in soils NaCl is most prominent. Inside the plant, Na⁺ has detrimental effects on cell functioning, by interfering negatively with protein and membrane stability and causing ROS production. In order to control Na⁺ homeostasis, plants have

different Na⁺ transporters to protect the plant against damage due to Na⁺ accumulation: antiporters in the root that extrude Na⁺ back to the soil in a mechanism coupled to H⁺ transport (involving the SOS pathway) [4,5]; transporters that retrieve Na⁺ from the transpiration stream avoiding the over-accumulation of Na⁺ in the photosynthetic tissues (involving HKT transporters) [6,7]; and antiporters that sequester Na⁺ in the vacuoles (involving NHX1 antiporters), along the electrochemical gradient created by the H⁺-ATPase and the H⁺-PPase [8]. HKT transporters, with special emphasis on members of class I, are one of the most studied Na⁺ permeable transporters [9]. These Na⁺ transporters, often located in xylem parenchyma cells and root epidermal cells have been found in many plant species and recent studies have shown their crucial importance in salinity tolerance in both mono- and dicotyledonous species [10-13]. This makes HKT transporters a preferential target for the engineering of plant stress tolerance.

This review will discuss the latest research developments on HKT transporters in mono- and dicotyledonous plants paying attention to the recently characterized HKT members, data on ion selectivity, HKT regulation and residues in the HKT protein with important functions for the transport characteristics of the respective proteins.

HKT1 vs. HKT2 – Does the nomenclature still hold?

Since the discovery of TaHKT2;1 in 1994 [14], many more HKT transporters from other species and with different transport characteristics have been discovered, eliciting a lively debate about the *in planta* role of these transporters. Upon discovery, HKT transporters from various species received the same name independent from their different transport characteristics [14,15]. In 2006 an international agreement was reached on HKT nomenclature with a classification in two groups according to their transport characteristics [16], with differences in the amino acid in the first pore domain (PD) of the protein as the main distinguishing feature [6,17,18]. Members of class I (Table 1) possess a serine (S) at this position (the other 3 PD's have a glycine (G) residue forming a motif of S-G-G-G), whereas members of class II (Table 2) possess a G in all PD's (G-G-G-G motif) [16]. The presence of either an S or G at this particular position determines the selectivity of the transporter [18]. The presence of an S is associated with a preference for Na⁺ conductance over that of other cations, whereas the presence of a G enables the transporters to select for either Na⁺ and/or K⁺ depending on the external concentrations of these two ions [10]. The role of the S and G in the first PD is explained in more detail in the Section: *Residues important in the correct HKT functioning*.

Table 1. List of all HKT1 transporters isolated and characterized.

Transporter	Expression in planta	Ref.	Function in planta	Ref.	Transport selectivity when heterologous expressed	Ref.
AtHKT1;1	Phloem (roots and shoots)	[19]	Loading excessive shoot Na ⁺ into the phloem	[19]	Na ⁺ transport (<i>Xenopus</i> oocytes) K ⁺ transport (<i>E. coli</i>)	[15]
	Xylem parenchyma cells	[12,20,21]	Unloading of Na ⁺ from the xylem into XPC	[12,20,21]		
OsHKT1;1	In the leaves: bulliform cells and vascular tissues. In the roots: similar to OsHKT2;1.	[17,22]			Na ⁺ transport (<i>Xenopus</i> oocytes and <i>S. cerevisiae</i> yeast cells)	[17,22]
OsHKT1;2	Not detected in roots. Expression does not change with NaCl stress in the leaves.	[23]				
OsHKT1;3	In the leaves: bulliform cells and vascular tissues, mesophyll cells. In the roots: cortex and vascular tissues in the stele.	[22]			Na ⁺ transport (<i>Xenopus</i> oocytes)	[22]
OsHKT1;4	Leaf sheaths.	[24]	Control of sheath-to-blade transfer of Na ⁺	[24]		
OsHKT1;5	Mainly expressed in xylem parenchyma cells of both roots and leaves.	[11]	Control of root-to-shoot transfer of Na ⁺ by unloading of Na ⁺ from the xylem into XPC	[11]	Na ⁺ transport (<i>Xenopus</i> oocytes)	[11]
TaHKT1;4	Expressed in the roots, leaf sheath and leaf blades.	[25]	Unloading of Na ⁺ from the xylem into XPC	[25]		
TaHKT1;5	Expressed in the roots but not in the shoots.	[7]	Unloading of Na ⁺ from the xylem into XPC	[7,13]	Na ⁺ transport (<i>S. cerevisiae</i> cell) Na ⁺ transport (<i>Xenopus</i> oocytes)	[13]
	Ubiquitously expressed (roots, stems, leaves, flowers, fruits). NIL and treatment dependent	[26]			Na ⁺ transport (<i>S. cerevisiae</i> cells) Na ⁺ transport (<i>Xenopus</i> oocytes)	[26] Almeida <i>et al.</i>

Table 1. Continuation.

Transporter	Expression in planta	Ref.	Function in planta	Ref.	Transport selectivity when heterologous expressed	Ref.
SlHKT1;2	Ubiquitously expressed (roots, stems, leaves, flowers, fruits). NIL and treatment dependent	[26]			No transport activity detected in either <i>S. cerevisiae</i> cells or <i>Xenopus</i> oocytes	[26] Almeida <i>et al.</i> unpublished results
EcHKT1;1	Expressed in the leaves, stems and roots	[27]			K ⁺ transport (<i>E. coli</i> cells) Na ⁺ , K ⁺ and Rb ⁺ transport (<i>Xenopus</i> oocytes)	[27,28]
EcHKT1;2	Expressed in the leaves, stems and roots	[27]			K ⁺ transport (<i>E. coli</i> cells) Na ⁺ , K ⁺ , Rb ⁺ , Li ⁺ Transport (<i>Xenopus</i> oocytes)	[27,28]
McHKT1;1	In the leaves: xylem parenchyma cells and phloem cells; In the roots: epidermal cells and vascular tissues	[29]	The authors proposed a model where McHKT1;1 Unloads Na ⁺ from the xylem in the shoots	[29]	K ⁺ transport (<i>S. cerevisiae</i> cells) Rb ⁺ , Cs ⁺ , K ⁺ , Na ⁺ and Li ⁺ transport (<i>Xenopus</i> oocytes)	[29]

Table 2. List of all HKT2 transporters isolated and characterized.

Transporter	Expression in planta	Ref.	Function in planta	Ref.	Transport selectivity when heterologous expressed	Ref.
OsHKT2;1	In the roots: epidermis, exodermis, cortex differentiated into aerenchyma, stele (mainly in the phloem); In the leaves: bulliform cells, xylem, phloem, mesophyll cells	[22]	Nutritional Na ⁺ uptake from the external medium	[10]	Na ⁺ and K ⁺ transport (<i>Xenopus</i> oocytes) Na ⁺ transport (<i>S. cerevisiae</i> cells) K ⁺ transport (<i>S. cerevisiae</i> cells)	[22,30,31]] [17,31] [30]
OsHKT2;2	Expressed only in the roots	[32]	Na ⁺ /K ⁺ symporter in BY2 tobacco cells Expected to co-transport both Na ⁺ and K ⁺ in conditions of K ⁺ starvation	[33] [32]	Na ⁺ , K ⁺ , (<i>S. cerevisiae</i> and <i>Xenopus</i> oocytes)	[31,34]
OsHKT2;2/1	Expressed only in the roots	[32]	Expected to co-transport both Na ⁺ and K ⁺ in the roots in conditions of low K ⁺ and under salt stress	[32]	Na ⁺ and K ⁺ transport (<i>S. cerevisiae</i> cells and <i>Xenopus</i> oocytes)	[32]
OsHKT2;3	Marginally expressed in the roots in comparison to the shoots	[34]			No currents or uptake observed in <i>Xenopus</i> oocytes or <i>S. cerevisiae</i> cells	[34]
OsHKT2;3	Marginally expressed in the roots in comparison to the shoots	[34]			No currents or uptake observed in <i>Xenopus</i> oocytes or <i>S. cerevisiae</i> cells	[34]
OsHKT2;4	Vasculature of primary/ lateral root cells, leaf sheaths, spikelets and the base of stems. Expressed also in mesophyll cells	[35]	Possible role in K ⁺ homeostasis as a K ⁺ transporter/channel Possible redundant role in planta as <i>oshkt2;4</i> mutants show no phenotype Proposed to function as a K ⁺ transporter involved in both nutritional K ⁺ uptake and long-distance K ⁺ transport	[34] [35] [36]	Permeable to NH ₄ ⁺ , Li ⁺ , Na ⁺ , K ⁺ , Ca ²⁺ , Mg ²⁺ , Zn ²⁺ , Mn ²⁺ , Cu ²⁺ , Fe ²⁺ , Cd ²⁺ (<i>Xenopus</i> oocytes) Permeable to Na ⁺ , K ⁺ , Mg ²⁺ , Ca ²⁺ (<i>Xenopus</i> oocytes) K ⁺ transport (<i>S. cerevisiae</i> cells) Na ⁺ and K ⁺ transport (<i>Xenopus</i> oocytes)	[35] [34] [36]

Table 2. Continuation.

Transporter	Expression in planta	Ref.	Function in planta	Ref.	Transport selectivity when heterologous expressed	Ref.
TaHKT2;1	Root cortical and stele cells Vascular tissue of mesophyll cells	[14]	Na ⁺ uptake from the external medium	[37]	Permeable to Na ⁺ , K ⁺ , Cs ⁺ and Rb ⁺ (<i>Xenopus</i> oocytes) K ⁺ transport (<i>S. cerevisiae</i> cells) Na ⁺ and K ⁺ transport (<i>S. cerevisiae</i> cells)	[14] [39,40]
PutHKT2;1	Mainly in roots	[38]	Possible high affinity K ⁺ transporter	[38]	Na ⁺ and K ⁺ transport (<i>Xenopus</i> oocytes) Permeable to Na ⁺ , K ⁺ and Mg ⁺ (<i>Xenopus</i> oocytes) Na ⁺ and K ⁺ transport (<i>S. cerevisiae</i> cells)	[34] [38]
HvHKT2;1	Root cortex, leaf blades and leaf sheaths	[41,42]	Possible involvement in the root K ⁺	[41,42]	Na ⁺ and K ⁺ transporter (<i>S. cerevisiae</i> and <i>Xenopus</i> oocytes)	[41,42,44]
PhaHKT2;1	Roots and shoots	-----	(re)absorption at very low K ⁺ concentrations		Na ⁺ and K ⁺ transport (<i>S. cerevisiae</i> cells)	[38,43]
PpHKT1	-----		Possible uptake of Na ⁺ in the roots		Na ⁺ and K ⁺ uptake (<i>S. cerevisiae</i> cells)	[45]

Although the simplicity of this classification makes it appealing, reality shows that the list with exceptions is growing. A larger number of exceptions to this list might bring again confusion over the nomenclature and transport characteristics, as the selectivity and affinity of many HKT transporters are different from that indicated by their name. From all the exceptions, OsHKT2;1 is probably the most studied transporter [1,10,22,23,31,33]. Although OsHKT2;1 possesses an S in the first PD it can transport K^+ [10,30]. Another rice HKT transporter with an unusual conductance is OsHKT2;4 [34-36]. OsHKT2;4 is able to transport both Ca^{2+} and Mg^{2+} [34,35]. Another exception to the rule is TsHKT1;2, which has an S in the first PD, but has a higher affinity for K^+ than Na^+ [46]. Surprisingly, this seems to be due to other amino acid residues in the protein than those present at the first PD.

Class I HKT transporters – Essential roles in Na^+ detoxification

As discussed above, Class I HKT transporters are low affinity transporters with specificity for Na^+ [3]. Some of these members locate to the plasma membrane of root stele cells, in particular, xylem parenchyma cells (XPC). They function by retrieving Na^+ from the xylem sap and prevent Na^+ from reaching the shoots and damage photosynthetic cells. The number of HKT1 family members varies between mono- and dicotyledonous plants. Monocotyledonous plants have more HKT1 members than dicotyledonous [1,11,17,22]. All class I HKT1 transporters isolated from monocotyledonous plants and characterized so far show selectivity for Na^+ only [1,11,17,22]. In this section we will discuss the roles of several Class I HKT transporters with emphasis on AtHKT1;1, OsHKT1;4/5 and TaHKT1;4/5 and their roles in *Arabidopsis*, rice and wheat.

***Arabidopsis* AtHKT1;1**

The first Class I HKT1 member was isolated from *Arabidopsis thaliana* [15]. When expressed in *Xenopus laevis* oocytes AtHKT1;1 showed Na^+ selective transport activity independent from K^+ [15]. Mutant K^+ uptake yeast cells ($\Delta trk1 \Delta trk2$) transformed with *AtHKT1;1* were not able to grow on medium containing 1 mM K^+ and their growth was reduced in medium containing Na^+ [15].

At the plant level, AtHKT1;1 was first suggested to mediate Na^+ uptake from the external medium [47]. This AtHKT1;1 function was soon discarded as experiments done with *Arabidopsis* wild-type and *athkt1;1* mutant plants revealed no differences

in root Na⁺ uptake [19,48,49]. Besides, *AtHKT1;1* is expressed in the root stele and in the leaf vasculature but not in the root tips, which would not favour a role in Na⁺ uptake from the external medium [6]. *AtHKT1;1* expression was shown in phloem cells of both roots and leaves [19]. Later, immunological detection of AtHKT1;1 in cross-sections of vascular bundles of *Arabidopsis* leaves showed localization of AtHKT1;1 to the plasma membrane of XPC [21]. Cell-specific *AtHKT1;1* expression in the pericycle [20] and in the stelar [12] cells of *Arabidopsis thaliana* plants via an enhancer trap system [50] resulted in decreased Na⁺ accumulation in the shoots and an increased NaCl tolerance in comparison to the parental lines [12,20]. A similar experiment where *AtHKT1;1* was expressed in the root cortex of rice showed the same increase in Na⁺ sequestration in the roots and reduced transport to the shoots with an increase in salinity tolerance of transgenic rice plants [20]. These results suggest, that in *Arabidopsis*, over-expression of *AtHKT1;1* in the roots, independently of the tissue, results in improved salinity tolerance through higher Na⁺ sequestration of Na⁺ in the root and reduced Na⁺ transport to the shoots. Interestingly, over-expression of *AtHKT1;1* under the CaM-³⁵S promoter [12] or even the endogenous promoter [51] rendered the plants more salt sensitive, possibly due to an increased unidirectional influx of Na⁺ into the roots of these plants [12]. The results on the *AtHKT1;1* cell specific expression [12,20] indicate that the improvement of salinity tolerance requires cell type-specific *AtHKT1;1* over-expression.

All results obtained with AtHKT1;1 show that the main role of AtHKT1;1 *in planta* is to avoid the accumulation of excessive Na⁺ in the shoots of *Arabidopsis* [12,19-21]. Na⁺ exclusion from the shoots and photosynthetic tissues has long been proposed as a mechanism of salinity tolerance [7,11,12,20,25,45,52-54]. However, two *Arabidopsis* ecotypes collected from the coastal areas of Tossa del Mar, Spain and Tsu, Japan, (Ts-1 and Tsu-1), respectively, accumulate higher shoot levels of Na⁺ than Col-0 due to the presence of a weak *AtHKT1;1* allele that is not expressed in the roots [55]. The lack of correlation between shoot Na⁺ concentration and salinity tolerance in *Arabidopsis thaliana* ecotypes has been described as well [56]. In contrast with *athkt1;1* mutant plants, this novel *AtHKT1;1* allele in Ts-1 and Tsu-1 does not confer NaCl sensitivity, and, in fact, co-segregates with higher tolerance to NaCl [55]. The analyses of the offspring produced by a cross between Tsu-1 and Col-0 wild-type revealed that Tsu-1 *HKT1;1* homo- and heterozygous plants were able to survive longer in the presence of 100 mM NaCl in comparison to Col-0 homozygous plants

[55]. Another explanation for this phenotype is, that a second unknown gene and not the weak *AtHKT1;1* allele is responsible for the higher salinity tolerance. Due to a small genetic distance between this unknown gene and *AtHKT1;1*, both segregate together [55]. Although a great effort has been made, more research is necessary to unravel the role of *AtHKT1;1* unequivocally in the shoots of *Arabidopsis thaliana*.

Rice OsHKT1;x

In contrast to the small number of HKT1 members present in dicotyledonous plants, monocotyledonous plants have several *HKT1* genes [7,11,13,17,22,25]. In monocotyledonous plants the physiological role of HKT1 members *in planta* was revealed through the discovery that a QTL controlling the accumulation of Na⁺ in the leaves of rice and wheat was traced down to Class I HKT transporters [7,11,25]. In rice, a trait (*SKC1*) involved in maintaining higher shoot K⁺ concentrations during salinity stress was identified, isolated and characterized [11]. Comparison of *SKC1* cDNA with available database sequences showed that *SKC1* corresponded to *OsHKT1;5* (*OsHKT8*) [11]. Analysis of gene expression, Na⁺ and K⁺ accumulation in the roots and in the shoots and heterologous expression in *Xenopus laevis* oocytes further supported a similar role of *OsHKT1;5* in rice [11] as for *AtHKT1;1* in *Arabidopsis thaliana* [15,21]. Rice contains four more HKT1 members in its genome, *OsHKT1;1*, *OsHKT1;2*, *OsHKT1;3* and *OsHKT1;4* [11,17,22,24].

In saline conditions, *OsHKT1;4* is expressed in the sheaths [24]. Although three different *OsHKT1;4* transcripts are present in the rice lines Pokkali and Nipponbare, only the amount of the correct spliced transcript inversely correlates with the concentration of Na⁺ in individual leaf blades in both lines [24]. This points clearly to the role of the full length *OsHKT1;4* in control of the sheath-to-blade transfer of Na⁺ in the shoots of rice [24].

OsHKT1;1 is expressed in the roots (epidermis, exodermis and cortex differentiated into aerenchyma) and in the shoots it is expressed in bulliform cells and vascular tissues, both xylem and phloem [17,22]. When expressed in yeast cells, only Na⁺ transport is observed and kinetic analysis showed a low affinity Na⁺ uptake competitively inhibited by K⁺ and Rb⁺, although Rb⁺ was not transported by *OsHKT1;1* [17]. In *Xenopus oocytes* *OsHKT1;1* shows characteristics of a Na⁺ inward rectifying transporter mediating no outward currents; the currents display voltage-dependent properties upon

hyperpolarized pulses [22]. The expression of *OsHKT1;1* in bulliform cells might point to different physiological roles *in planta* in comparison to other rice HKTs.

Although mainly expressed in the shoots, *OsHKT1;3* is also detected in the roots, the cortex and in the vascular tissues of the stele. In comparison to *OsHKT1;1* and *OsHKT2;1* it shows a stronger labelling in the phloem [22]. In the leaves, it is expressed in bulliform cells where the staining is particularly strong, but also in the vascular tissues, both xylem and phloem [22]. Although yeast cells expressing *OsHKT1;3* did not mediate any type of transport [17], in *Xenopus laevis* oocytes *OsHKT1;3* mediated both inward and outward Na^+ currents with weak inward rectification [22]. *OsHKT1;2* has not been thoroughly studied as other HKT members in rice. *In planta*, *OsHKT1;2* was not detected in the roots and in the leaves its expression did not change significantly upon treatment with Na^+ and K^+ [23].

Wheat TaHKT1;4/5

In wheat, QTL analyses using a novel durum wheat, Line 149, (*Triticum turgidum* L. subsp. *Durum*), identified two loci, *Nax1* [25], and *Nax2* [7], involved in Na^+ exclusion from the xylem and reduced Na^+ export to the shoots [7,25]. Moreover, the hexaploid bread wheat (*Triticum aestivum*) containing the genomes A, B and D, is more salt tolerant than the tetraploid durum wheat containing the genomes A and B [57,58]. It was discovered that the D genome carries a locus (*Kna1*) responsible for maintenance of high K^+/Na^+ ratio during salt stress which renders bread wheat salt tolerant [58,59]. The three *Triticum* sp QTLs *Nax1*, *Nax2* and *Kna1* control both the removal of Na^+ from the xylem and the accumulation of Na^+ in leaf sheaths [7,25,60]. Using fine mapping *Nax1* and *Nax2* were identified as members of the *HKT1;4* gene family [25] and *Kna1* as member of the *HKT1;5* gene family [7]. Because both *Nax* genes originated from a wheat relative, *Triticum monococcum*, that was crossed with a durum wheat, they were named *TmHKT1;4-A2* and *TmHKT1;5-A*, respectively [60,61]. The *Nax2* region of Line 149 was found to correspond to the *Kna1* region of the bread wheat and *Kna1* was named *TaHKT1;5-D* [7]. These genes clearly have similar functions as *AtHKT1;1* in *Arabidopsis* and *OsHKT1;5* and *OsHKT1;4* in rice [11,21,24,61,62], what was supported by the reduction of the Na^+ accumulation in the leaves of bread wheat plants, where both *Nax1* and *Nax2* genes were introduced through conventional hybridization, growing under saline and water logged conditions [60]. Moreover, field trials in saline soils done with durum wheat carrying the

TmHKT1;5-A gene showed that leaf Na⁺ accumulation was reduced and grain yield increased by 25% compared to near-isogenic lines without the *Nax2* locus [13]. These results showed that *HKT* genes have a crucial role in the salinity tolerance of wheat plants.

Tomato HKT1;1 and HKT1;2

In tomato (*Solanum lycopersicum*) two *HKT* genes were detected to be closely linked [26]. These two genes were analysed by heterologous expression in a yeast strain mutated for K⁺ uptake. Both SIHKT1;1 and SIHKT1;2 were unable to complement the growth of the yeast mutant in the presence of low K⁺ in the medium. Cells expressing *SIHKT1;1* were able to deplete external Na⁺, showing that SIHKT1;1 is a Na⁺-selective transporter [26]. No transport activity was detected in yeast cells expressing *SIHKT1;2* for either Na⁺ or K⁺ [26]. The Na⁺ selectivity of SIHKT1;1 and the absence of transport activity in SIHKT1;2 were also observed in our lab in experiments where *SIHKT1;1* and *SIHKT1;2* expressing oocytes were characterized (Almeida and de Boer, unpublished data). Expression analysis of *SIHKT1;1* and *SIHKT1;2* showed ubiquitous expression in roots, stems, leaves, flowers and fruits. The results by Asins *et al.* [26] suggest that not only in monocots (as done so far), but also in dicot plants, *HKT* genes might be revealed by QTL studies.

Class II HKT transporters – A role for K⁺

In contrast to Class I HKTs, members of Class II HKT have been shown to have a role in Na⁺ uptake from the external medium, particularly when K⁺ is limiting [10,23,37,42]. In K⁺ limiting conditions, HKT2 transporters show an up-regulation in expression [9,11,23,31,33,42].

OsHKT2;1

OsHKT2;1 is an unusual class II transporter [63], as it has an S residue in the first PD and its Na⁺ transport capacity is similar to class I members. However, OsHKT2;1 is also able to transport K⁺ depending on the external concentrations of both Na⁺ and K⁺ [9,10,22]. Characterization studies using heterologous expression of *OsHKT2;1* in yeast cells and *Xenopus* oocytes revealed that OsHKT2;1 mediates both inward and outward Na⁺ currents [22]. Depending on the external concentration of Na⁺ and K⁺, OsHKT2;1 showed several permeation modes: Na⁺/K⁺ symport when Na⁺ and K⁺

were present at sub-millimolar concentrations, Na⁺ uniport in the presence of Na⁺ at millimolar range and K⁺ at sub-millimolar range, or inhibited states when K⁺ was present in the millimolar range up to 10 mM [17,22,31]. In roots, *OsHKT2;1* is expressed in peripheral layers (epidermis, exodermis and cortex differentiated into aerenchyma), which agrees with a function in ion uptake from the external medium. In the stele it is mainly expressed in the phloem and in the leaves it is expressed in bulliform cells and vascular tissues, both xylem and phloem [22]. *In planta*, *OsHKT2;1* takes up Na⁺ from the external medium as concluded from the large reduction in Na⁺ uptake observed in the *oshkt2;1* mutant in comparison to wild type plants [10].

The K⁺ starvation driven Na⁺ uptake mediated by *OsHKT2;1* in rice is the so-called nutritional Na⁺ absorption [10] that is used by plants when grown at high salinity conditions and that allows for the replacement of K⁺ by Na⁺ [10,64]. In these conditions moderate levels of Na⁺ are beneficial as they can be used in osmotic balance [65]. The replacement of K⁺ by Na⁺ is, however, limited as high external concentrations of Na⁺ down-regulate *HKT*, especially *OsHKT2;1* [10,17]. Although in rice only *OsHKT2;1* is known to be involved in nutritional Na⁺ absorption, accumulation of *mRNAs* of other rice *HKT* members were also reduced by external Na⁺ concentrations of 30 mM [31].

TaHKT2;1

In wheat, *TaHKT2;1* seems to have a similar function in root Na⁺ influx as *OsHKT2;1* has in rice [9]. *TaHKT2;1* is expressed in the root cortex [14], and like *OsHKT2;1* in rice, *TaHKT2;1* expression is enhanced by K⁺ starvation [66]. In cortex cells, K⁺ starvation enhanced Na⁺ influx currents [67]. When expressed in the salt sensitive G19 yeast cells, an increased Na⁺ sensitivity of the cells was observed [39,40], although not as strong as the sensitivity caused by *OsHKT2;1* [31]. When expressed and analysed in *Xenopus laevis* oocytes, *TaHKT2;1* mediated both Na⁺ and K⁺ transport [14], and probably Mg²⁺ [34]. *In planta*, a role of *TaHKT2;1* in K⁺ uptake seems unlikely [68] and a role in Mg²⁺ uptake was not tested. The anti-sense repression of *TaHKT2;1* expression in wheat plants resulted in a decrease in Na⁺ uptake by the roots and reduced Na⁺ translocation to the shoots, but K⁺ homeostasis was not affected [37]. These results provide evidence that *TaHKT2;1* most probably, has a role in Na⁺ transport [37,42]. The results of the repression of *TaHKT2;1* expression support the

notion that Na^+ exclusion from the shoots is an essential mechanism in wheat salinity tolerance [37].

HvHKT2;1

Like other HKT2;1 members of monocots, *HvHKT2;1* is preferentially expressed in the root cortex and to a much lower level in leaf blades and sheaths. Its expression is up-regulated by low external K^+ and high Na^+ in both roots and shoots, and in shoots, respectively [42]. When expressed in both yeast cells and *Xenopus laevis* oocytes *HvHKT2;1* is shown to co-transport Na^+ and K^+ [41,42,44]. In oocytes, like *OsHKT2;1*, the transport characteristics vary according to the external concentrations of Na^+ and K^+ .

HvHKT2;1 differs from *TaHKT2;1* in the capacity to maintain the K^+ transport activity in the absence of Na^+ . *TaHKT2;1* requires the presence of Na^+ to be able to take up K^+ , whereas the K^+ uptake by *HvHKT2;1* is maintained in the absence of Na^+ , although it is reduced [42]. Transgenic barley lines over-expressing *HvHKT2;1* showed higher growth rates in the presence of both 50 and 100 mM Na^+ and a constant K^+ concentration of 2 mM. Interestingly, the over-expressing barley plants displayed higher Na^+ concentrations in the xylem, enhanced translocation of Na^+ to the shoots and higher Na^+ accumulation in the leaves than the wild type control plants. Over-expression of *HvHKT2;1* reinforced the inculder phenotype of barley resulting in more salt tolerant plants [42]. The over-expression of *HvHKT2;1* also resulted in increased K^+ contents in plants grown in the “absence” of K^+ suggesting that *HvHKT2;1* could be involved in the root K^+ absorption at very low concentrations of K^+ [42].

In conclusion, these three HKT2;1 transporters display common properties in their cell specific expression and their ability to transport both Na^+ and K^+ when expressed in heterologous systems. They also show inhibition of Na^+ transport by K^+ , what becomes visible above a certain threshold of Na^+ concentration [13,31,42].

Other Class II HKT members

OsHKT2;2

The salt tolerant Nona Boktra and Pokkali cultivars express *OsHKT2;2*, a homologue of *OsHKT2;1*, which is absent in the rice sensitive Nipponbare cultivar [31]. This suggests that the presence of *OsHKT2;2* is an evolutionary advantage for the salt

tolerant cultivars [32]. When expressed in *Xenopus* oocytes *OsHKT2;2* shows both Na⁺ transport activity in the presence of K⁺ and *vice versa* [31], and also a small Mg²⁺ permeability [34]. The results for Na⁺ and K⁺ obtained with *Xenopus laevis* oocytes were also observed in *OsHKT2;2* expressing tobacco BY2 cells, showing that *OsHKT2;2* works as a Na⁺/K⁺ co-transporter in plant cells as well [33].

***OsHKT2;2/1*, a new HKT isoform in rice**

Recently, a chimeric *OsHKT* member from the salt tolerant rice cultivar Nona Bokra was isolated [32]. This member has a 5' region corresponding to that of *OsHKT2;2*, but a 3' region corresponding to that of *OsHKT2;1*. This new member was called *OsHKT2;2/1* and it resulted from a 15 kb deletion in chromosome 6 of Nona Bokra, resulting in a chimera between the 5' end of *OsHKT2;2* and the 3' end of *OsHKT2;1* [32]. Expression of *OsHKT2;2/1* in *Xenopus laevis* oocytes or *Saccharomyces cerevisiae* cells revealed that *OsHKT2;2/1* is permeable to both Na⁺ and K⁺, the latter even in the presence of high external Na⁺ concentrations [32]. This behaviour of *OsHKT2;2/1* was more similar to *OsHKT2;2* than to *OsHKT2;1* [32]. Like *OsHKT2;1* and *OsHKT2;2*, *OsHKT2;2/1* expression in the roots was up-regulated in K⁺ free conditions. In contrast to *OsHKT2;1*, *OsHKT2;2/1* was only expressed in the roots and in conditions of salt stress its expression was reduced but not abolished [32]. Over time, this reduction in *OsHKT2;2/1* expression was less severe than the reduction in *OsHKT2;1* and *OsHKT2;2*, what suggests that *OsHKT2;2/1* may play a role in the roots in conditions of low K⁺ concentrations and under salt stress [32].

OsHKT2;3

OsHKT2;3 shows about 93% homology to *OsHKT2;4* at the amino acid level [34]. When expressed in the K⁺ uptake-deficient CY162 yeast cells growing under K⁺ limiting conditions, *OsHKT2;3* was not able to rescue the K⁺ uptake phenotype. When *OsHKT2;3* was expressed in the salt sensitive G19 yeast cells growing in the presence of NaCl, no differences in growth were observed in comparison to cells transformed with the empty vector [17,34]. Also in *Xenopus laevis* oocytes expressing *OsHKT2;3* no currents were observed in the presence of alkali cations [34]. *OsHKT2;3* is marginally expressed in the roots when compared to the expression in the shoots [17], and its expression does not change due to different Na⁺ and K⁺

concentrations in the growing medium [23]. More research is necessary to unravel the physiological role of this HKT member.

OsHKT2;4, a HKT member with unusual transport characteristics, involved in Ca²⁺ signaling?

OsHKT2;4 is a rice HKT member with unusual transport characteristics, the nature of which still leaves room for discussion [34-36]. When expressed in oocytes, *OsHKT2;4* produced currents containing two components with different kinetics which were different from all HKTs described [35]. It was first reported that, in the presence of Na⁺, K⁺ or even Mg²⁺, *OsHKT2;4* expressing oocytes produced currents that were smaller than those obtained with the mixture of the bath cations including also Ca²⁺ [35]. When Ca²⁺ was tested as the current carrier, it generated time dependent currents at hyperpolarizing voltages. Besides Ca²⁺, K⁺ and Na⁺, *OsHKT2;4* expressing oocytes were also permeable to other divalent cations, namely Mg²⁺, Zn²⁺, Mn²⁺, Cu²⁺, Fe²⁺ and Cd²⁺ [35]. Based on the results obtained with K⁺ and Ca²⁺ channel blockers, the existence of two binding sites in OsHKT2;4 for cation transport was proposed [35]. However, this hypothesis was refuted by the results of the crystal structure of VpTrkH, a bacterial member of the HKT/Ktr/Trk family [36]. These results confirmed, the presence of one single central pore in each monomeric transporter, not supporting the existence of two distinct permeation pathways [69]. HKT/Ktr/Trk transporters share a typical structure which might have derived from that of an ancestral K⁺ channel subunit [36,70,71].

Later, it was reported that in *OsHKT2;4* expressing oocytes, K⁺ caused the most positive reversal potentials and that both Mg²⁺ and Ca²⁺ had a small permeability that was inhibited by K⁺, suggesting a higher permeability of K⁺ in comparison to the other cations [34]. Increases in the K⁺ concentration in the absence of Na⁺ resulted in shifts of the reversal potential to more positive values showing that OsHKT2;4 transported K⁺ also in the absence of Na⁺ and indicating that OsHKT2;4 was not an obligate Na⁺-K⁺ co-transporter [34]. This implied that OsHKT2;4 was more likely a K⁺ channel/transporter rather than a Na⁺-K⁺ co-transporter [34]. In fact, increases in the external Na⁺ concentration caused only small positive shifts in the reversal potential, showing that OsHKT2;4 transport properties were different from other class II HKT transporters as these showed large positive shifts in the reversal potential when the external Na⁺ concentration was increased [22,28,31,39,72].

Recently, it was reported that *OsHKT2;4* expressing *Xenopus laevis* oocytes did not produce any currents in the presence of either Ca^{2+} or Mg^{2+} , even when K^+ was present at very low concentrations, suggesting that *OsHKT2;4* was not permeable to either of these two divalent cations [36]. In this study, the effect of Na^+ present in excess of K^+ in the external medium was also analysed. In contrast to the results obtained before [34], Sassi and co-workers reported that in these conditions Na^+ was the main ion being transported and not K^+ [36]. When K^+ was present at similar or higher concentrations than Na^+ , the main ion being transported was K^+ , as increments in the Na^+ concentration were without any effect on the current reversal potential [36]. These last results seem to confirm that, like *OsHKT2;1*, *OsHKT2;4* has also different conduction modes depending on the external Na^+ concentration [34,36], although *OsHKT2;4* shows a high K^+ and a singularly low Na^+ permeability as compared with the other class II HKT transporters [22,73].

Although only *OsHKT2;2* was shown to transport K^+ when expressed in BY2 tobacco cells [33], the expression pattern together with the high K^+ permeability of *OsHKT2;4* when expressed in oocytes, might suggest a role of this HKT member in uptake and long distance transport of K^+ *in planta* [34-36].

In conclusion, the presence or absence of *OsHKT2;2* and *OsHKT2;2/1* seems to be an evolutionary advantage for the salt tolerant cultivars. This advantage might be related to a role in K^+ homeostasis not only of *OsHKT2;2* and *OsHKT2;2/1* but also of *OsHKT2;4*.

Do HKT transporters isolated from mosses and clubmosses form a third class?

A Blast search allowed the identification and isolation of an *HKT* member from the moss *Physcomitrella patens* and several *HKT* genes from the club moss *Selaginella moellendorffii* [63]. A phylogenetic tree made with all known HKT protein sequences, revealed that these (club) moss HKT genes do not belong to either of the two HKT subfamilies [16]. A third HKT subfamily was therefore suggested for these (club) moss HKT members because the accepted *HKT* nomenclature [16] cannot be used for these HKT members [63].

The expression of *PpHKT1* in yeast cells defective in K^+ uptake and unable to take up Na^+ from low Na^+ concentrations showed that *PpHKT1* mediates both K^+ and Na^+ influx [63]. However, when *Physcomitrella patens* wild-type and *pphkt1* mutant moss were grown at different Na^+ and K^+ concentrations, including K^+ starving conditions,

no effects were observed on either the growth rate or on the K^+ or Na^+ contents. Moreover, the expression of *PpHKT1* remained low and was not affected by either K^+ starvation, different pH values, or the presence of Na^+ [63]. These results are different from those obtained with both Class I and Class II HKT members characterized so far and might be linked to the different morphology and living conditions of mosses in comparison to mono- and dicotyledonous plants. More research with *HKT* members isolated from other mosses and club mosses is necessary to confirm whether the transport and expression characteristics of *PpHKT1* are similar among mosses and club mosses. It will also be interesting to identify and characterize *HKT* members isolated from plants belonging to old genera like *Ginkgo* and *Magnoliacea*. This would reveal whether these *HKT* members share more characteristics with primitive or with modern plants.

HKT regulation

Although the involvement of HKT transporters in Na^+ and K^+ homeostasis (depending on the specific HKT transporter) is well established, the picture of the mechanism(s) that control the expression and activity of HKT transporters is far from complete. Several reports have, however, attempted to bring light to this topic. In this section we will discuss several mechanisms involved in the regulation of *HKT* genes and proteins (Figure 1).

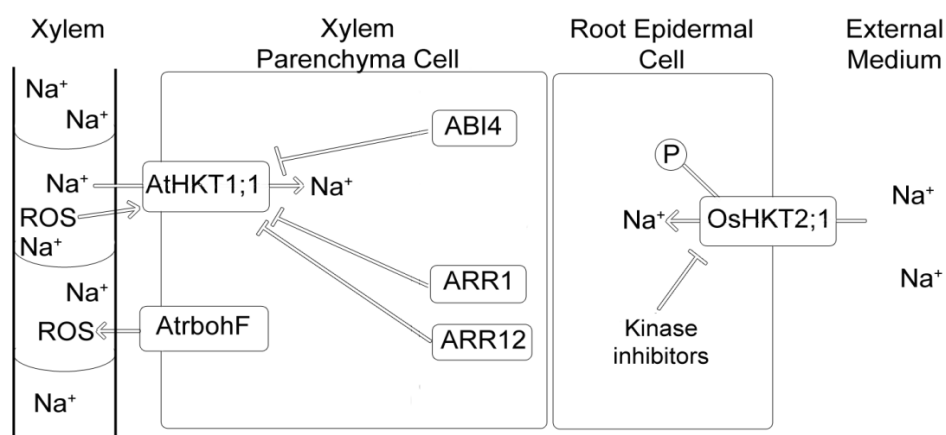

Figure 1: Mechanisms involved in the regulation of HKT transporters. Cytokinins and ABI4 down regulate the expression of *AtHKT1;1* whereas the presence of ROS in the xylem stream affects expression or activity of *AtHKT1;1*. In rice, the application of

phosphorylation inhibitors causes a severe reduction in Na⁺ influx in the root epidermal cells.

Promoter structure

Surprisingly little is known about the role of promoter structure in transcriptional regulation of *HKT* genes. Tissue specific regulation of *AtHKT1;1* gene expression seems to be achieved through the action of a distal enhancer element and a small RNA-mediated DNA methylation [74]. The *AtHKT1;1* promoter has two tandem repeats (R1 and R2) that act to repress (R1) or enhance (R2) *AtHKT1;1* expression. Besides, the *AtHKT1;1* promoter also contains a putative small RNA target region that presents higher methylation levels in the leaves in comparison to the roots [74]. It was proposed that this difference in methylation may contribute to the higher *AtHKT1;1* expression in the roots [74]. Both coastal ecotypes *Ts-1* and *Tsu-1* [55], show only one copy of the tandem repeat which is more similar to R1 of Col-0 [74]. This repeat might be associated with the weak *AtHKT1;1* allele present in these two ecotypes and with the higher accumulation of Na⁺ observed in the shoots [55]. This raises an interesting question about the tissue tolerance of *Ts-1* and *Tsu-1*. How does this ecotype combine elevated Na⁺ accumulation in the shoots but also a higher salinity tolerance in comparison to other *Arabidopsis* ecotypes? One explanation is that *Ts-1* and *Tsu-1* have a better shoot vacuolar Na⁺ sequestration system than Col-0 and use the high Na⁺ levels to reduce their cellular water potential. Another explanation is that, due to the small genetic distance, a second unknown gene responsible for the higher salinity tolerance segregates together with *AtHKT1;1* in these two ecotypes [55].

Regulation by ROS

Several studies using *Arabidopsis* mutants lacking detoxification enzymes [75], enzymes involved in the production of ROS [76], or treatment of wild-type plants with inhibitors of enzymes involved in the production of ROS [77], showed that increases and decreases in ROS accumulation *in planta* were related to higher and lower salinity tolerance, respectively. A study with the *Arabidopsis* mutant *atrbohF* (*Arabidopsis thaliana* respiratory burst oxidase protein F), showed that *AtRbohF* increases root vascular ROS levels in response to salinity, thereby reducing the amount of Na⁺ in the xylem and, consequently, the amount of Na⁺ exported to the

shoots [78]. One hypothesis to explain the effect of AtRbohF on xylem Na⁺ levels is that ROS stimulates AtHKT1;1 expression or activity, because AtHKT1;1 is involved in Na⁺ unloading from the xylem (Figure 1) [6,12,19,21,49]. Additionally, it was shown that *AtRbohF* is also expressed in the root vascular tissue with salinity stress enhancing its expression, and that in non-transpiring conditions the *atrbohF* phenotype is not observed [74]. Changes in ROS levels in the vasculature may be an important determinant of transporter activity, since also the activity of the outward rectifying K⁺-channel SKOR (expressed in XPC's) is enhanced by ROS [79].

Regulation by Cytokinins

It has long been known that salinity stress changes the cytokinin levels in plants [80], and that, in turn, cytokinin plays a role in the response to salt stress [81]. The expression of all cytokinin receptors and several type-A response regulators is affected by salt treatment [82,83] and loss of function mutations in the cytokinin receptor genes make plants less sensitive to salt [83]. A comparison between the *Arabidopsis* type-B regulator double mutant *atarr1-3arr1-12* (from hereon called *atarr1-12*), which makes the plants insensitive to cytokinin, and wild-type plants demonstrated that cytokinin has a role in Na⁺ accumulation in plants. External application of cytokinin resulted in a higher accumulation of Na⁺ in the shoots of wild-type plants (46% increase) as compared to that in the shoots of *atarr1-12* mutant plants (21% increase) in comparison to non-treated controls [81]. The mutant plants are also less sensitive to salt stress [81]. *AtHKT1;1* gene expression analysis showed that the *atarr1-12* mutant has a 6.2 fold higher expression of *AtHKT1;1* in the roots but no significant changes in the shoots in comparison to wild-type, suggesting that *ARR1-3* and *ARR1-12* transcription factors regulate *AtHKT1;1* expression in the roots (Figure 1) [81]. A microarray study also showed that, in the presence of 200 mM NaCl, the *Arabidopsis* cytokinin deficient *ipt1,3,5,7* mutant had a much higher *AtHKT1;1* expression in comparison to the wild type plants [84]. The fact that the expression pattern of *AtHKT1;1* [6,21] and *ARR1-3* and *ARR1-12* [85] overlaps in the vascular tissue of the root further supports the conclusion that cytokinin signalling controls *AtHKT1;1* expression [81]. Also, treatment of wild type plants with external cytokinin resulted, after only 4 hours, in a reduction in *AtHKT1;1* expression by 87%, whereas this same treatment on *atarr1-12* mutants resulted in only a 21% reduction in the *AtHKT1;1* expression, what confirms the role of cytokinin in the regulation of *AtHKT1;1* [81].

Although these results clearly prove the effect of cytokinin on the expression of *AtHKT1;1*, the molecular basis for this regulation is still unknown. It was suggested that the cell specific expression of *AtHKT1;1* could be restricted by ARR1 and ARR12 through induction of repressor genes in specific cell types that reduce *AtHKT1;1* expression [81].

Experiments done with the plant growth promoting rhizobacteria *Bacillus subtilis* strain *GB03* showed that the volatiles released by this bacteria strain induced changes in *AtHKT1;1* expression both in root (reduction) and shoot (increase) [86]. Amongst the volatiles produced, 2,3-butanediol was shown to be the major effector of growth stimulation in the presence of salt [86]. A later study showed that the *Arabidopsis ein2* (*cytokinin/ ethylene-insensitive*) and *cre1* (*cytokinin receptor-deficient*) mutants showed no response to the volatiles produced by *GB03* [87], confirming that the effect of 2,3-butanediol on the *AtHKT1;1* expression is achieved through cytokinin signaling. Whether the *GB03* induced reduction in root *AtHKT1;1* expression is mediated by ARR1-3 and ARR1-12 is not known yet.

Regulation by ABI4

ABI4 (*ABSCISIC ACID INSENSITIVE4*) is an ABA responsive transcription factor which acts both as activator and repressor of transcription [88]. The *Arabidopsis abi4* mutant displayed enhanced salinity tolerance, whereas *ABI4* over-expressing plants displayed hypersensitivity to salinity, in comparison to wild type plants [89]. This sensitivity was observed from the stage of germination to adult stages. The increased salinity tolerance of *abi4* mutants correlated with higher *AtHKT1;1* expression (Figure 1) in the roots and lower Na⁺ accumulation in the shoots. The opposite was observed for plants over-expressing *ABI4*. The reduced *AtHKT1;1* expression in wild type *Arabidopsis*, in comparison to the *HKT1;1* expression in *abi4* mutant plants, was shown to be due to the binding of *ABI4* to the proximal *AtHKT1;1* promoter region. This repressor effect on *AtHKT1;1* expression was absent in *abi4* mutant plants [89]. These results shed more light on the regulation of *AtHKT1;1* expression. Moreover, the fact that the *abi4* mutant showed enhanced salinity tolerance not only at the germination stage but also at later stages of development, suggests that, in the presence of NaCl, *abi4* mutant plants are more adapted to face salinity stress.

Residues important for HKT function

As discussed above, certain residues in the HKT transporters have a crucial role in the functioning of the transporter (Figure 2). Here we present the list of all residues that were shown to play an important role in the ion selectivity of several HKT transporters.

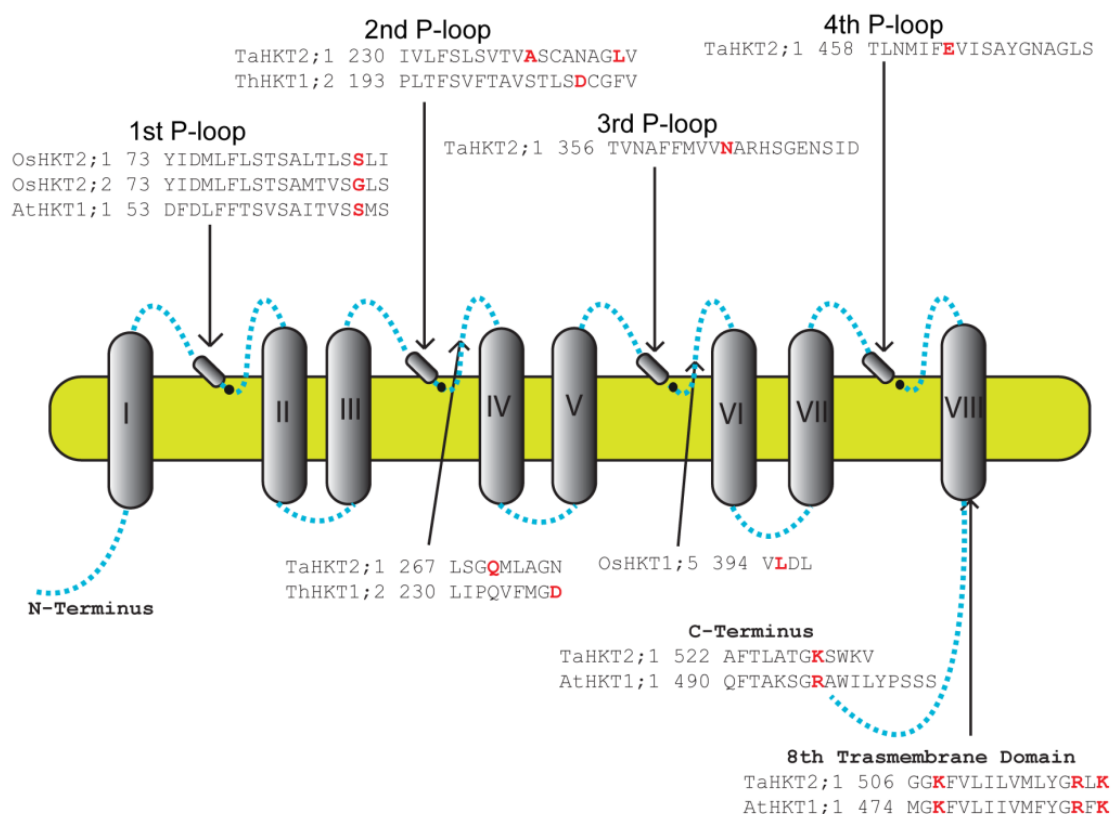

Figure 2: HKT structure and location of specific amino acids that were shown to affect the transport properties when mutated. Alignments show the amino acid sequence of specific domains where these amino acids (highlighted in red) are present (different plant species) and have been shown to have a crucial role in the correct functioning of the transporter. The function of the highlighted amino acids has been studied by expression of the mutated proteins in heterologous systems.

TaHKT2;1-expressing salt sensitive yeast cells growing in the presence of NaCl, [39,40] allowed the discovery of four *TaHKT2;1* mutants conferring less salt sensitivity to yeast cells. Yeast cells expressing the mutant forms *TaHKT2;1-A₂₄₀V* or *TaHKT2;1-L₂₄₇F* [39], and *TaHKT2;1-Q₂₇₀L* or *TaHKT2;1-N₃₆₅S* [40], showed growth rates higher than those expressing the wild-type transporter. Experiments done with

Xenopus oocytes confirmed that the four mutations reduced low affinity Na⁺ uptake [39,40]. In *A_{240V}*- and *L_{247F}*- [39], and in *Q_{270L}*- and *N_{365S}*- [40] expressing yeast cells the inward low affinity Na⁺ currents were reduced in comparison to wild-type currents. These four mutations reduced the Na⁺ inhibition of high affinity Rb⁺ uptake [39,40], showing the importance of these four residues in the Na⁺ binding capacity of TaHKT2;1. Also in wheat, it was shown that the mutation of glutamate E₄₆₄ to glutamine Q₄₆₄ in TaHKT2;1 affects the normal function of the transporter [90]. K⁺ uptake deficient yeast cells CY162 expressing *TaHKT2;1-E_{464Q}* showed enhanced growth in the presence of 50 mM NaCl compared with 0 mM NaCl whereas the growth of *TaHKT2;1* expressing cells was slightly decreased. This enhancement in the growth of TaHKT2;1-E_{464Q} was much larger in the presence of low NaCl concentrations (2.5 mM), in contrast to the growth of TaHKT2;1 expressing cells which was reduced at the same concentrations [90]. Na⁺ uptake measurements showed that the E_{464Q} mutation reduced the affinity of TaHKT2;1 for Na⁺, by affecting how TaHKT2;1 binds Na⁺ and reducing Na⁺ flux rates but showing no effect on K⁺ binding [90]. These results suggest the involvement of the 4th P-loop region of the TaHKT2;1 in the Na⁺ binding and transport through the transporter.

To study the first PD, several point mutations of the predicted first PD of AtHKT1;1, TaHKT2;1, OsHKT2;1 and OsHKT2;2 proteins were produced and used to study the role of specific amino acids present in the first PD of these HKT transporters. The mutated *AtHKT1;1-S_{88G}* and *OsHKT2;1-S_{88G}* expressing CY162 yeast cells were able to grow at low concentrations of K⁺ while *AtHKT1;1* and *OsHKT2;2-G_{88S}* expressing cells were not [18]. From these experiments it was concluded that the presence of a G at the predicted filter position of the first PD is necessary and sufficient for K⁺ permeation of AtHKT1;1, TaHKT2;1 and OsHKT2;2 [18].

A later paper, where several positive residues from the M₂D segment of both AtHKT1;1 and TaHKT2;1 were mutated, [91], showed that these residues also have an important role in the normal functioning of HKT transporters in plants. The replacement of arginine (R) R₅₁₉ in TaHKT2;1 and R₄₈₇ in AtHKT1;1 by alanine (A), glutamine (Q), glutamic acid (E) and lysine (K), was analysed in CY162 yeast cells and *Xenopus laevis* oocytes. All yeast cells transformed with *TaHKT2;1* or mutated *TaHKT2;1* were able to grow in the presence of 1 mM KCl, although differences were

observed ($R_{519}K = WT > R_{519}Q > R_{519}A > R_{519}E$). Similar experiments done with AtHKT1;1 showed that only oocytes expressing *AtHKT1;1* and $R_{487}K$ produced Na^+ currents. These results led to the conclusion that R_{519} in TaHKT2;1 or R_{487} in AtHKT1;1 plays an important role in the ion transport [91]. Other positively charged amino acids present in the M₂D domain were also mutated namely the lysine (K) K_{508} , K_{521} , and K_{529} in TaHKT2;1 and K_{476} , K_{489} , and R_{497} in AtHKT1;1, and the cation transport activity analysed in *Xenopus laevis* oocytes. $K_{508}Q$ and $R_{519}Q$ showed reduced transport activity compared to $K_{521}Q$ and $K_{529}Q$ [91]. These results showed that the individual replacement of positively charged amino acids with Q in the M₂D domain do not delete the cation uptake activity of plant HKT.

Thellungiella salsuginea, an *Arabidopsis* relative, possesses two *HKT* genes, *TsHKT1;1* and *TsHKT1;2*, which are induced by NaCl [46]. Because the sodium specific responses of *Arabidopsis* and *Thellungiella* are different with respect to *HKT* expression, *TsHKT-RNAi* lines were created and their salinity sensitivity analysed. *TsHKT-RNAi* lines showed no differences in growth under control conditions but showed sensitivity to sodium compared to the control. RNAi lines growing in hydroponics treated with 250 mM NaCl for 24 h showed decreased K^+ accumulation and smaller K^+/Na^+ ratios in the shoots and marginally higher in the roots pointing to a role of TsHKT1;2 in the maintenance of K^+ homeostasis [46]. The K^+ specificity of TsHKT1;2 was found to rely on the presence of two aspartic acid (D) residues located at positions D₂₀₇ and D₂₃₈. When these two residues, individually or together, were replaced by asparagine (N) residues, present in the AtHKT1;1, each single change resulted in the reduction of the growth of the transformed CY162 yeast cells growing in the presence of Na^+ and low concentrations of K^+ . These results showed that, in the case of TsHKT1;2, which shows a S residue in the first PD, two specific D residues have a strong effect on the selectivity of the transporter [46]. It would be interesting to test whether the mutation of the S present in the first PD into a G has any effect on the K^+ selectivity of this transporter.

Recently, it was shown that the differences in whole plant Na^+ (Na^+ retention in the root and Na^+ transport rates), between rice cultivars was due to an amino acid substitution in the OsHKT1;5 transporter [24]. Both Pokkali and Nona Bokra cultivars are salt tolerant, presenting a lower total plant Na^+ accumulation, higher Na^+ retention in the roots and faster Na^+ transport rates. These characteristics were associated with the presence of a valine (V) residue at position V₃₉₅ of OsHKT1;5. The salt sensitive

Nipponbare cultivar shows, in turn, higher Na⁺ transfer to the shoots and slower Na⁺ transport rates, these being features associated with a leucine (L) residue at position L₃₉₅ of OsHKT1;5 [24]. The V₃₉₅L amino acid substitution is located in close proximity of G₃₉₁ near the entrance of the pore in both transporters [24]. The slower Na⁺ transport rates shown by the OsHKT1;5 of Nipponbare is due to a larger van der Waals volume imposed by the side chain of L₃₉₅ [24]. Moreover, the presence of this residue can also influence other residues underlying the pore selectivity within the pore environment [24].

These examples show that besides the residues present at the PD also other residues located throughout the protein have crucial roles in the function of different HKT transporters.

The role in long-distance transport

Recirculation vs. Exclusion: evidence for both models

Although the ion selectivity of AtHKT1;1 was known [15], the lack of information about the exact cells in which AtHKT1;1 was expressed, did not allow a good understanding of the role of AtHKT1;1 *in planta*. Research done with *athkt1;1* showed that this mutation did ameliorate the *sos3* phenotype and reduced the total amount of Na⁺ in the seedlings, leading to the suggestion that AtHKT1;1 was a root Na⁺ influx pathway [47]. Subsequent studies showed however that the root Na⁺ influx in *athkt1;1* was not lower than in the wild-type *Arabidopsis* plants, discarding the role proposed by Rus and coworkers [19,48]. Nevertheless, immunolocalization of HKT in root tips of *Mesembryanthemum crystallinum*, showed that the protein was most concentrated in epidermal cells which may indicate an important role of McHKT1;1 in cation uptake from the soil [29]. A study performed with EMS *athkt1;1* mutant plants showed that these mutants accumulated less Na⁺ in the phloem sap but not in the xylem sap, when compared to wild-type plants growing in the presence of salinity [19]. This result on phloem Na⁺ content, in addition to a *AtHKT1;1* phloem-specific expression pattern, led to the hypothesis that AtHKT1;1 loads excessive Na⁺ from the shoots into the phloem. In this way, excess Na⁺ in the shoots would be transported back to the roots via the downward phloem flow, the so-called “recirculation” model [19]. Later studies showed that *athkt1;1* mutant plants accumulated Na⁺ to higher levels in the shoots and also in the xylem sap as compared to wild type plants [21]. In this work an AtHKT1;1 antibody and *AtHKT1;1* promoter GUS construct were used

to detect the location of the proteins and cell specific expression, respectively. Results from both experiments showed that AtHKT1;1 was present xylem parenchyma cells (XPC) [21]. Based on these results the authors proposed the “exclusion” model [21]. This model proposed that AtHKT1;1 acts by unloading Na^+ from the xylem sap into XPC in the roots avoiding excessive amounts of Na^+ to reach the shoots via the transpiration stream [21]. Nowadays the “recirculation” model has been questioned based on the preferential localization of AtHKT1;1 in XPC [12,20,21]. Moreover, data based on unidirectional Na^+ tracer fluxes indicated a lack of AtHKT1;1 functioning in the recirculation of Na^+ via the phloem [12,49,52,61]. The xylem Na^+ unloading function of AtHKT1;1 was also supported by the results of cell specific over-expression of *AtHKT1;1* [12,20]. In these experiments, an enhancer-trap system [50], was used to guide the over-expression of *AtHKT1;1* specifically in the root. The increase in Na^+ influx into the transformed parenchyma cells created more Na^+ tolerant plants [12,20].

Although the function of AtHKT1;1 is quite well defined in the roots, the opposite is true for the shoots and the “recirculation” model [19] should not be discarded. In fact, both Na^+ transport processes could be linked to achieve recirculation of Na^+ as ions retrieved from the xylem to the XPC could be loaded into the phloem through symplastic diffusion [92]. In cross-sections of *Mesembryanthemum crystallinum* leaves, *McHKT1;1* was detected in vascular bundles and surrounding mesophyll cells [29]. Although the signals in the vasculature were stronger for XPC, also phloem and phloem-associated cells were highlighted [29]. Also in reed plants, PhaHKT2;1 might have a role in Na^+ recirculation through the phloem [43]. Reed plants of the ecotype Nanpi had a functional PhaHKT2;1 where the ecotype Utsonomiya expressed a splice variant. When treated with salt for 10 days, the plants with the correct splicing variant, Nanpi, contained less Na^+ in the above ground tissues than Utsonomiya plants and accumulated Na^+ in the roots. In contrast, Utsonomiya plants had high Na^+ levels in the shoot [93]. Moreover, in Nanpi plants, the Na^+ content in the shoots first increased, but decreased to levels in the control plants after 10 days of treatment, while Utsonomiya plants showed a continuous increase upon treatment [93]. These results suggest that in Nanpi plants, the functional HKT2;1 is able to retrieve Na^+ from the xylem in the roots avoiding high concentrations of Na^+ from reaching the shoots, but also that in the shoots it might be involved in loading of Na^+ into the phloem and, consequently, in the recirculation of Na^+ to the roots. Also in the leaves

of two rice varieties, Pokkali and IR29, *OsHKT2;1* was expressed in cells adjacent to phloem vessels suggesting the involvement of this transporter in Na⁺ and K⁺ recirculation [30]. In *Arabidopsis*, although weaker in comparison to the staining in the XPC, GUS staining signals were also found in the shoot in the vicinity of phloem tissues [21]. Thus, the role of HKT transporters in Na⁺ recirculation is not yet clear and more data will be necessary to validate the “recirculation” model [19].

HKT and K⁺ levels in the xylem – a direct or indirect effect of HKT

The maintenance of high K⁺ concentrations during events of salinity stress reduces the Na⁺/K⁺ ratio in the plant leaves and is often referred to as crucial for salinity tolerance in glycophyte plants [3]. When first described, AtHKT1;1 was tested in several heterologous systems [15]. Whereas both over-expression in *Xenopus oocytes* and yeast showed AtHKT1;1 to work as a Na⁺ selective uniporter, over-expression in a *E. coli* K⁺ uptake mutant showed an increase in its K⁺ accumulation [15]. *athkt1;1* plants growing in the presence of 75 mM NaCl had higher concentrations of Na⁺ but lower concentrations of K⁺ present in the xylem and in the shoots [21]. In the rice cultivar Koshihikari, *HKT1;5* encodes a protein with low transport activity which leads to a more salt sensitive phenotype in comparison with the salt tolerant cultivar Nona Bokra [11]. Also here a reduced concentration of K⁺ in the shoot of the salt sensitive rice cultivar was observed when grown in the presence of 140 mM NaCl [11]. In a more recent paper, the over-expression of *AtHKT1;1* in the root stele (through the use of a trap-enhancer system) [50], resulted in the reduction of Na⁺ and in the increase of K⁺ concentration in the shoots of plants growing in the presence of NaCl compared with the controls [12]. In this case it was concluded that this increase in K⁺ shoot concentration was a pleiotropic consequence of the reduced Na⁺ shoot content [12].

As shown by these examples, the mechanisms coordinating the levels of Na⁺ and K⁺ remain obscure, because the literature does not show any evidence for the direct role of AtHKT1;1 in the transport of K⁺ *in planta* [12]. Nevertheless, all these observations fit the hypothesis that the uptake of Na⁺ from the xylem into the XPC via HKT1;1 will result in the depolarization of XPCs and activation of K⁺ efflux channels which in turn will release K⁺ into the xylem [21]. This hypothesis also explains the higher K⁺ accumulation in the roots of *athkt1;1* mutant plants [21]. Recently, patch-clamp experiments done with root stelar cells of *AtHKT1;1* wild-type and *athkt1;1* mutant plants showed large currents activated by voltage ramps, in both wild-type and

mutant plants, in the presence of 50 mM KCl (bath) and 5 mM KCl (pipette) [94]. Analysis of the reversal potentials and amplitude of the currents formed in both plant types showed no significant differences, suggesting that K^+ is not substantially transported by AtHKT1;1 [94]. An alternative hypothesis to explain a role for the AtHKT1;1 protein in K^+ -transport is that the AtHKT1;1 protein directly interacts with another cation transport protein and affects the activity of such a protein. The first large-scale interaction screen of membrane and signaling proteins (MIND; <http://cas-biodb.cas.unt.edu/project/mind/index.php>) shows three putative interaction partners of AtHKT1;1, a glycolyl hydrolase, a glutamate receptor (AtGLR2.9) and KEA3, a cation:proton antiporter. It will be important to find out whether any of these proteins plays a role in K^+ -transport from the root to the shoot.

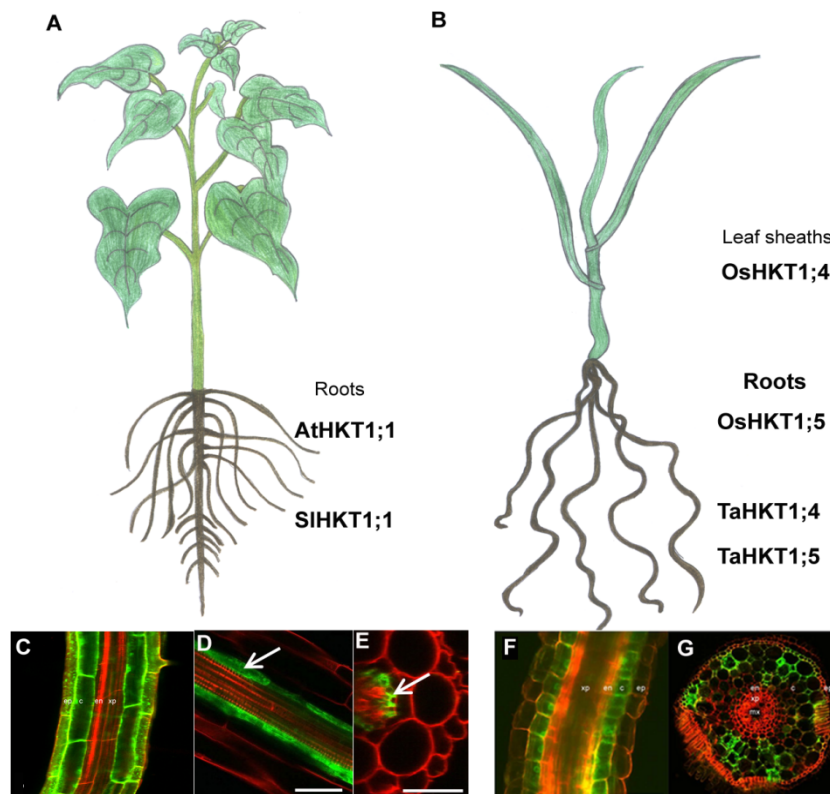

Figure 3: Targeted expression of *AtHKT1;1* in the roots of both (A) dicotyledonous and (B) monocotyledonous plants. The targeted over-expression of *AtHKT1;1* in the roots, regardless of the tissue as both over-expression in the (C) epidermal and cortical cells as well as (D and E) in the pericycle, resulted in enhanced salinity tolerance in *Arabidopsis thaliana* plants. Also in rice the overexpression of *AtHKT1;1* in the (F and G) epidermis and cortical cells resulted also in enhanced salinity

tolerance. This might be a useful strategy to use with other HKT genes to ameliorate the salt sensitivity of crop species. Bars: (C) 75 μm , (D and E) 40 μm , (F and G) 100 μm . Figure 3C,F,G reproduced with permission from [20]. Figures 3D,E reproduced with permission from [12].

Future prospects

The constant growth of the world population in combination with the increase in salinized land areas make the generation of more salt tolerant cultivars a goal of utmost importance. Research on the physiological roles of class I HKT transporters like AtHKT1;1, and HKT1;4 and HKT1;5 from rice and wheat, as well as all other discovered HKT transporters will give important information that can be used to engineer salinity tolerant cultivars. For example, the studies by Moller *et al.* and Plett *et al.* provided evidence that targeted over-expression in the roots of both monocotyledonous and dicotyledonous plants results in increased salinity tolerance (Figure 3) [12,20]. As AtHKT1;1, SlHKT1;1 and HKT1;4 and HKT1;5 from both rice and wheat are orthologous and share the same functions *in planta*, this strategy might be useful in the engineering of salt tolerant crop plants.

Although a great deal of information about HKT transporters has been collected in the past years, some questions still need to be addressed and some topics clarified. Are HKT transporters involved in the recirculation of Na^+ via the phloem, or is this mechanism HKT-independent? Where does the Na^+ retrieved from the xylem to the XPC go? Also, how is the high Na^+ mediated down-regulation of class II HKT achieved? With the exception of *oshkt2;1* and *oshkt2;4* [34] mutants, HKT mutants in monocots are still unavailable. The generation of other *HKT* mutants in monocots will be useful to better understand the *in vivo* functions of other HKT transporters already discovered and characterized via heterologous systems. Is the enhanced salinity tolerance revealed by the *Arabidopsis* ecotypes Ts1-1 and Ts-1 related only to the weak allele or also to an unknown gene co-segregating with the *AtHKT1;1* gene? The possibility of another gene involved in salinity tolerance being co-segregated with *AtHKT1;1* in these two ecotypes would allow new approaches to the generation of salt tolerant plants. Are HKT2;1 members involved in high affinity K^+ uptake *in planta*? Last, should HKT nomenclature be revised? With the increasing number of papers reporting the identification of HKT members with unusual transport characteristics, it

will be a matter of time until the actual nomenclature will no longer be able to classify all members in an easy and simple way. And should a third class grouping HKT transporters isolated from mosses and club mosses be formed?

References

1. Huang S, Spielmeyer W, Lagudah ES, Munns R (2008) Comparative mapping of *HKT* genes in wheat, barley, and rice, key determinants of Na⁺ transport, and salt tolerance. *Journal of Experimental Botany* 59: 927-937.
2. Rengasamy P (2006) World salinization with emphasis on Australia. *Journal Experimental Botany* 57: 1017-1023.
3. Munns R, Tester M (2008) Mechanisms of salinity tolerance. *Annual Review of Plant Biology* 59: 651-681.
4. Shi H, Ishitani M, Kim CS, Zhu JK (2000) The *Arabidopsis thaliana* salt tolerance gene *SOS1* encodes a putative Na⁺/H⁺ antiporter. *Proceedings fo Natural Academy of Sciences USA* 97: 6896-6901.
5. Shi HZ, Lee BH, Wu SJ, Zhu JK (2003) Overexpression of a plasma membrane Na⁺/H⁺ antiporter gene improves salt tolerance in *Arabidopsis thaliana*. *Nature Biotechnology* 21: 81-85.
6. Maser P, Eckelman B, Vaidyanathan R, Horie T, Fairbairn DJ, et al. (2002) Altered shoot/root Na⁺ distribution and bifurcating salt sensitivity in *Arabidopsis* by genetic disruption of the Na⁺ transporter AtHKT1;1. *FEBS Letters* 531: 157-161.
7. Byrt CS, Platten JD, Spielmeyer W, James RA, Lagudah ES, et al. (2007) HKT1;5-like cation transporters linked to Na⁺ exclusion loci in wheat, *Nax2* and *Kna1*. *Plant Physiology* 143: 1918-1928.
8. Ape MP, Aharon GS, Snedden WA, Blumwald E (1999) Salt tolerance conferred by overexpression of a vacuolar Na⁺/H⁺ antiport in *Arabidopsis*. *Science* 285: 1256-1258.
9. Horie T, Hauser F, Schroeder JI (2009) HKT transporter-mediated salinity resistance mechanisms in *Arabidopsis* and monocot crop plants. *Trends in Plant Science* 14: 660-668.
10. Horie T, Costa A, Kim TH, Han MJ, Horie R, et al. (2007) Rice OsHKT2;1 transporter mediates large Na⁺ influx components into K⁺-starved roots for growth. *The EMBO Journal* 26: 3003-3014.
11. Ren ZH, Gao JP, Li LG, Cai XL, Huang W, et al. (2005) A rice quantitative trait locus for salt tolerance encodes a sodium transporter. *Nature Genetics* 37: 1141-1146.
12. Moller IS, Gilliham M, Jha D, Mayo GM, Roy SJ, et al. (2009) Shoot Na⁺ exclusion and increased salinity tolerance engineered by cell type-specific alteration of Na⁺ transport in *Arabidopsis*. *Plant Cell* 21: 2163-2178.
13. Munns R., James RA, Xu B, Athman A, Conn JS, et al. (2012) Wheat grain yield on saline soils is improved by an ancestral Na⁺ transporter gene. *Nature Biotechnology* 30: 360-364.
14. Schachtman DP, Schroeder JI (1994) Structure and transport mechanism of a high-affinity potassium uptake transporter from higher-plants. *Nature* 370: 655-658.
15. Uozumi N, Kim EJ, Rubio F, Yamaguchi T, Muto S, et al. (2000) The *Arabidopsis HKT1* gene homolog mediates inward Na⁺ currents in *Xenopus laevis* oocytes and Na⁺ uptake in *Saccharomyces cerevisiae*. *Plant Physiology* 122: 1249-1259.
16. Platten JD, Cotsaftis O, Berthomieu P, Bohnert H, Davenport RJ, et al. (2006) Nomenclature for HKT transporters, key determinants of plant salinity tolerance. *Trends in Plant Science* 11: 372-374.
17. Garcíadeblas B, Senn ME, Banuelos MA, Rodríguez-Navarro A (2003) Sodium transport and HKT transporters: the rice model. *Plant Journal* 34: 788-801.

18. Maser P, Hosoo Y, Goshima S, Horie T, Eckelman B, et al. (2002) Glycine residues in potassium channel-like selectivity filters determine potassium selectivity in four-loop-per-subunit HKT transporters from plants. *Proceedings of the National Academy of Sciences of the United States of America* 99: 6428-6433.
19. Berthomieu P, Conejero G, Nublat A, Brackenbury WJ, Lambert C, et al. (2003) Functional analysis of AtHKT1 in *Arabidopsis* shows that Na⁺ recirculation by the phloem is crucial for salt tolerance. *EMBO Journal* 22: 2004-2014.
20. Plett D, Safwat G, Gilliam M, Moller IS, Roy S, et al. (2010) Improved salinity tolerance of rice through cell type-specific expression of *AtHKT1;1*. *PloS One* 5.
21. Sunarpi, Horie T, Motoda J, Kubo M, Yang H, et al. (2005) Enhanced salt tolerance mediated by AtHKT1 transporter-induced Na⁺ unloading from xylem vessels to xylem parenchyma cells. *Plant Journal* 44: 928-938.
22. Jabnourne M, Espeout S, Mieulet D, Fizames C, Verdeil JL, et al. (2009) Diversity in expression patterns and functional properties in the rice HKT transporter family. *Plant Physiology* 150: 1955-1971.
23. Wu YS, Hu YB, Xu GH (2009) Interactive effects of potassium and sodium on root growth and expression of K⁺/Na⁺ transporter genes in rice. *Plant Growth Regulation* 57: 271-280.
24. Cotsaftis O, Plett D, Shirley N, Tester M, Hrmova M (2012) A two-staged model of Na⁺ exclusion in rice explained by 3D modeling of HKT transporters and alternative splicing. *PLoS One* 7: e39865.
25. Huang SB, Spielmeyer W, Lagudah ES, James RA, Platten JD, et al. (2006) A sodium transporter (HKT7) is a candidate for *Nax1*, a gene for salt tolerance in durum wheat. *Plant Physiology* 142: 1718-1727.
26. Asins JM, Villalta I, Aly MM, Olias R, Morales PA, et al. (2012) Two closely linked tomato *HKT* coding genes are positional candidates for the major tomato QTL involved in Na⁺/K⁺ homeostasis. *Plant, Cell and Environment* 36: 1171-1191.
27. Fairbairn DJ, Liu WH, Schachtman DP, Gomez-Gallego S, Day SR, et al. (2000) Characterisation of two distinct HKT1-like potassium transporters from *Eucalyptus camaldulensis*. *Plant Molecular Biology* 43: 515-525.
28. Liu W, Fairbairn DJ, Reid RJ, Schachtman DP (2001) Characterization of two HKT1 homologues from *Eucalyptus camaldulensis* that display intrinsic osmosensing capability. *Plant Physiology* 127: 283-294.
29. Su H, Balderas E, Vera-Estrella R, Golldack D, Quigley F, et al. (2003) Expression of the cation transporter *McHKT1* in a halophyte. *Plant Molecular Biology* 52: 967-980.
30. Golldack D, Su H, Quigley F, Kamasani UR, Munoz-Garay C, et al. (2002) Characterization of a HKT-type transporter in rice as a general alkali cation transporter. *Plant Journal* 31: 529-542.
31. Horie T, Yoshida K, Nakayama H, Yamada K, Oiki S, et al. (2001) Two types of HKT transporters with different properties of Na⁺ and K⁺ transport in *Oryza sativa*. *Plant Journal* 27: 129-138.
32. Oomen RJ, Benito B, Sentenac H, rodriguez-Navarro A, Talon M, et al. (2012) HKT2;2/1, a K⁺ permeable transporter identified in a salt-tolerant rice cultivar through surveys of natural genetic polymorphism. *Plant Journal* 71: 750-762.
33. Yao X, Horie T, Xue SW, Leung HY, Katsuhara M, et al. (2010) Differential sodium and potassium transport selectivities of the rice OsHKT2;1 and OsHKT2;2 transporters in plant cells. *Plant Physiology* 152: 341-355.
34. Horie T, Brodsky DE, Costa A, Kaneko T, Lo Schiavo F, et al. (2011) K⁺ transport by the OsHKT2;4 transporter from rice with atypical Na⁺ transport properties and competition in permeation of K⁺ over Mg²⁺ and Ca²⁺ ions. *Plant Physiology* 156: 1493-1507.
35. Lan WZ, Wang W, Wang SM, Li LG, Buchanan BB, et al. (2010) A rice high-affinity potassium transporter (HKT) conceals a calcium-permeable cation channel. *Proceedings of the National Academy of Sciences of the United States of America* 107: 7089-7094.

36. Sassi A, Meieulet D, Khan I, Moreau B, Gaillard I, et al. (2012) The rice monovalent cation transporter OsHKT2;4: revisited ionic selectivity. *Plant Physiology* 160: 498-510.
37. Laurie S, Feeney KA, Maathuis FJM, Heard PJ, Brown SJ, et al. (2002) A role for HKT1 in sodium uptake by wheat roots. *Plant Journal* 32: 139-149.
38. Ardie SW, Xie L, Takahashi R, Liu S, Takano T (2009) Cloning of a high-affinity K⁺ transporter gene *PutHKT2;1* from *Puccinellia tenuiflora* and its functional comparison with OsHKT2;1 from rice in yeast and *Arabidopsis*. *Journal of Experimental Botany* 60: 3491-3502.
39. Rubio F, Gassmann W, Schroeder JI (1995) Sodium-driven potassium uptake by the plant potassium transporter HKT1 and mutations conferring salt tolerance. *Science* 270: 1660-1663.
40. Rubio F, Schwarz M, Gassmann W, Schroeder JI (1999) Genetic selection of mutations in the high affinity K⁺ transporter HKT1 that define functions of a loop site for reduced Na⁺ permeability and increased Na⁺ tolerance. *Journal of Biological Chemistry* 274: 6839-6847.
41. Haro R, Banuelos MA, Senn MAE, Barrero-Gil J, Rodriguez-Navarro A (2005) HKT1 mediates sodium uniport in roots. Pitfalls in the expression of *HKT1* in yeast. *Plant Physiology* 139: 1495-1506.
42. Mian A, Oomen RJ, Isayenkow S, Sentenac H, Maathuis FJ, et al. (2011) Overexpression of a Na⁺ and K⁺-permeable HKT transporter in barley improves salt tolerance. *Plant Journal* 68: 468-479.
43. Takahashi R, Liu S, Takano T (2007) Cloning and functional comparison of a high-affinity K⁺ transporter gene *PhaHKT1* of salt-tolerant and salt-sensitive reed plants. *Journal of Experimental Botany* 58: 4387-4395.
44. Banuelos MA, Haro R, Fraile-Escanciano A, Rodriguez-Navarro A (2008) Effects of polylinker uATGs on the function of grass HKT1 transporters expressed in yeast cells. *Plant and Cell Physiology* 49: 1128-1132.
45. Moller IS, Tester M (2007) Salinity tolerance of *Arabidopsis*: A good model for cereals? *Trends in Plant Science* 12: 534-540.
46. Ali Z, Park HC, Ali A, Oh D-H, Aman R, et al. (2012) TsHKT1;2, a HKT1 homolog from the extremophile *Arabidopsis* relative *Thellungiella salsuginea*, shows K⁺ specificity in the presence of NaCl. *Plant Physiology* 158: 1463-1474.
47. Rus A, Yokoi S, Sharkhuu A, Reddy M, Lee BH, et al. (2001) AtHKT1 is a salt tolerance determinant that controls Na⁺ entry into plant roots. *Proceedings of the National Academy of Sciences of the United States of America* 98: 14150-14155.
48. Essah PA, Davenport R, Tester M (2003) Sodium influx and accumulation in *Arabidopsis*. *Plant Physiology* 133: 307-318.
49. Davenport RJ, Munoz-Mayor A, Jha D, Essah PA, Rus A, et al. (2007) The Na⁺ transporter AtHKT1;1 controls retrieval of Na⁺ from the xylem in *Arabidopsis*. *Plant Cell and Environment* 30: 497-507.
50. Haseloff J (1999) GFP variants for multispectral imaging of living cells. *Methods Cell Biology* 58: 139-151.
51. Rus A, Lee BH, Munoz-Mayor A, Sharkhuu A, Miura K, et al. (2004) AtHKT1 facilitates Na⁺ homeostasis and K⁺ nutrition in planta. *Plant Physiology* 136: 2500-2511.
52. Tester M, Davenport R (2003) Na⁺ tolerance and Na⁺ transport in higher plants. *Annals of Botany* 91: 503-527.
53. Munns R (1993) Physiological processes limiting plant growth in saline soils: some dogmas and hypothesis. *Plant, Cell and Environment* 16: 15-24.
54. Munns R (2002) Salinity, growth and phytohormones. In *Salinity: Environment-Plants-Molecules* (eds A. Lauchli and U. Luttge), pp. 271-290. Kluwer Academic Publishers, Dordrecht, the Netherlands.
55. Rus A, Baxter I, Muthukumar B, Gustin J, Lahner B, et al. (2006) Natural variants of AtHKT1 enhance Na⁺ accumulation in two wild populations of *Arabidopsis*. *PLoS Genetics* 2: 1964-1973.

56. Jha D, Shirley N, Tester M, Roy SJ (2010) Variation in salinity tolerance and shoot sodium accumulation in *Arabidopsis* ecotypes linked to differences in the natural expression levels of transporters involved in sodium transport. *Plant Cell and Environment* 33: 793-804.
57. Gorham J, Bristol A, Young EM, Jones RGW, Kashour G (1990) Salt tolerance in the *Triticeae* - K^+/Na^+ discrimination in barley. *Journal of Experimental Botany* 41: 1095-1101.
58. Dubcovsky J, Santa-Maria G, Epstein E, Luo MC, Dvoak J (1996) Mapping of the K^+/Na^+ discrimination locus *Knal* in wheat. *Theoretical and Applied Genetics* 92: 448-454.
59. Gorham J, Hardy C, Wyn JRG, Joppa LR, Law CN (1987) Chromosomal location of a K^+/Na^+ discrimination character in the D genome of wheat. *Theoretical and Applied Genetics* 74: 584-588.
60. James RA, Blake C, Byrt CS, Munns R (2011) Major genes for Na^+ exclusion, *Nax1* and *Nax2* (wheat *HKT1;4* and *HKT1;5*), decrease Na^+ accumulation in bread wheat leaves under saline and waterlogged conditions. *Journal of Experimental Botany* 62: 2939-2947.
61. James RA, Davenport R. J., R. M (2006) Physiological characterisation of two genes for Na^+ exclusion in durum wheat: *Nax1* and *Nax2*. *Plant Physiology* 142: 1537-1547.
62. Plett DC, Moller IS (2010) Na^+ transport in glycophytic plants: what we know and would like to know. *Plant Cell and Environment* 33: 612-626.
63. Haro R, Banuelos MA, Rodriguez-Navarro A (2010) High-affinity sodium uptake in land plants. *Plant and Cell Physiology* 51: 68-79.
64. Horie T, Sugawara M, Okunou K, Nakayama H, Schroeder JI, et al. (2008) Functions of HKT transporters in sodium transport in roots and in protecting leaves from salinity stress. *Plant Biotechnology* 25: 233-239.
65. Rodriguez-Navarro A, Rubio F (2006) High-affinity potassium and sodium transport systems in plants. *Journal of Experimental Botany* 57: 1149-1160.
66. Wang TB, Gassmann W, Rubio F, Schroeder JI, Glass ADM (1998) Rapid up-regulation of *HKT1*, a high-affinity potassium transporter gene, in roots of barley and wheat following withdrawal of potassium. *Plant Physiology* 118: 651-659.
67. Buschmann PH, Vaidyanathan R, Gassmann W, Schroeder JI (2000) Enhancement of Na^+ uptake currents, time-dependent inward-rectifying K^+ channel currents, and K^+ channel transcripts by K^+ starvation in wheat root cells. *Plant Physiology* 122: 1387-1397.
68. Maathuis FJM, Ichida AM, Sanders D, Schroeder JI (1997) Roles of higher plant K^+ channels. *Plant Physiology* 114: 1141-1149.
69. Cao Y, Jin XS, Huang H, Derebe MG, Levin EJ, et al. (2011) Crystal structure of a potassium ion transporter, TrkH. *Nature* 471: 336-.
70. Durell SR, Guy HR (1999) Structural models of the KtrB, TrkH, and Trk1,2 symporters based on the structure of the KcsA K^+ channel. *Biophysical Journal* 77: 789-807.
71. Durell SR, Hao YL, Nakamura T, Bakker EP, Guy HR (1999) Evolutionary relationship between K^+ channels and symporters. *Biophysical Journal* 77: 775-788.
72. Gassmann W, Rubio F, Schroeder JI (1996) Alkali cation selectivity of the wheat root high-affinity potassium transporter HKT1. *Plant Journal* 10: 869-882.
73. Hauser F, Horie T (2010) A conserved primary salt tolerance mechanism mediated by HKT transporters: a mechanism for sodium exclusion and maintenance of high K^+/Na^+ ratio in leaves during salinity stress. *Plant Cell and Environment* 33: 552-565.
74. Baek D, Jiang JF, Chung JS, Wang BS, Chen JP, et al. (2011) Regulated *AtHKT1* gene expression by a distal enhancer element and DNA methylation in the promoter plays an important role in salt tolerance. *Plant and Cell Physiology* 52: 149-161.
75. Miller G, Suzuki N, Rizhsky L, Hegie A, Koussevitzky S, et al. (2007) Double mutants deficient in cytosolic and thylakoid ascorbate peroxidase reveal a complex mode of interaction between reactive oxygen species, plant development, and response to abiotic stresses. *Plant Physiology* 144: 1777-1785.

76. Kaye Y, Golani Y, Singer Y, Leshem Y, Cohen G, et al. (2011) Inositol polyphosphate 5-phosphatase7 regulates production of reactive oxygen species and salt tolerance in *Arabidopsis*. *Plant Physiology* 157: 229-241.
77. Leshem Y, Seri L, Levine A (2007) Induction of phosphatidylinositol 3-kinase-mediated endocytosis by salt stress leads to intracellular production of reactive oxygen species and salt tolerance. *The Plant Journal* 51: 185-197.
78. Jiang C, Belfield EJ, Mithani A, Visscher A, Ragoussis J, et al. (2012) ROS-mediated vascular homeostatic control of root-to-shoot soil Na⁺ delivery in *Arabidopsis*. *EMBO Journal* 31: 4359-4370.
79. Garcia-Mata C, Wang J, Gajdanowicz P, Gonzales W, Hills A, et al. (2010) A minimal cysteine motif required to activate the SKOR K⁺ channel of *Arabidopsis* by the reactive oxygen species H₂O₂. *Journal of Biological Chemistry* 285: 29286-29294.
80. Itai C, Richmond A, Vaadia Y (1968) The role of root cytokinins during water and salinity stress. *Israel Journal of Botany* 17: 187-195.
81. Mason MG, Jha D, Salt DE, Tester M, Hill K, et al. (2010) Type-B response regulators ARR1 and ARR12 regulate expression of *AtHKT1;1* and accumulation of sodium in *Arabidopsis* shoots. *Plant Journal* 64: 753-763.
82. Argueso CT, Ferreira FJ, Kieber JJ (2009) Environmental perception avenues: the interaction of cytokinin and environmental response pathways. *Plant Cell and Environment* 32: 1147-1160.
83. Tran L-SP, Urao T, Qin F, Maruyama K, Kakimoto T, et al. (2007) Functional analysis of AHK1/ATHK1 and cytokinin receptor histidine kinases in response to abscisic acid, drought, and salt stress in *Arabidopsis*. *Proceedings of the National Academy of Sciences of the United States of America* 104: 20623-20628.
84. Nishiyama R, Le TD, Watanabe Y, Matsui A, Tanaka M, et al. (2012) Transcriptome analysis of a salt-tolerant cytokinin-deficient mutant reveal differential regulation of salt stress response by cytokinin deficiency. *PLoS One* 7: e32124.
85. Mason MG, Li J, Mathews DE, Kieber JJ, Schaller GE (2004) Type-B response regulators display overlapping expression patterns in *Arabidopsis*. *Plant Physiology* 135: 927-937.
86. Zhang H, Kim MS, Sun Y, Dowd SE, Shi HZ, et al. (2008) Soil bacteria confer plant salt tolerance by tissue-specific regulation of the sodium transporter HKT1. *Molecular Plant-Microbe Interactions* 21: 737-744.
87. Ryu CM, Farag MA, Hu CH, Reddy MS, Wei HX, et al. (2003) Bacterial volatiles promote growth in *Arabidopsis*. *Proceedings of the National Academy of Sciences of the United States of America* 100: 4927-4932.
88. Wind JJ, Peviani A, Snel B, Hanson J, Smeekens S (2013) ABI4: versatile activator and repressor. *Trends in Plant Science* 18: 125-132.
89. Shkolnik-Inbar D, Adler G, Bar-Zvi D (2013) ABI4 downregulates expression of the sodium transporter *HKT1;1* in *Arabidopsis* roots and affects salt tolerance. *Plant Journal* 73: 993-1005.
90. Diatloff E, Kumar R, Schachtman DP (1998) Site directed mutagenesis reduces the Na⁺ affinity of HKT1, an Na⁺ energized high affinity K⁺ transporter. *FEBS Letters* 432: 31-36.
91. Kato N, Akai M, Zulkifli L, Matsuda N, Kato Y, et al. (2007) Role of positively charged amino acids in the M2_D transmembrane helix of Ktr/Trk/HKT type cation transporters. *Channels* 1: 161-171.
92. Pardo JM (2010) Biotechnology of water and salinity stress tolerance. *Current Opinion in Biotechnology* 21: 185-196.
93. Takahashi R, Nishio T, Ichizen N, Takano T (2007) High-affinity K⁺ transporter *PhaHAK5* is expressed only in salt-sensitive reed plants and shows Na⁺ permeability under NaCl stress. *Plant Cell Reports* 26: 1673-1679.
94. Xue S, Yao X, Luo W, Jha D, Tester M, et al. (2012) AtHKT1;1 mediates Nernstian sodium channel transport properties in *Arabidopsis* root stelar cells. *PLoS One* 6: e24725.

Chapter 8

General Discussion

As outlined in Chapter 1, salinity tolerance is a complex trait involving alterations of Na^+ and K^+ homeostasis, gene expression and osmolite accumulation [1,2]. Several research articles show that in some plant species salt tolerance relies on the expression of genes essential in the homeostasis of Na^+ *in planta*. Examples of these genes are the *HKT1* genes in *Arabidopsis* [3-6], *Thellungiella* [7], rice [8,9] and wheat [10,11]; the *SOS1* gene in *Arabidopsis* [12] and tomato [13] and the *NHX* genes in tomato [14]. Furthermore, genes encoding plasma membrane and vacuolar proton pumps involved in the generation of the electrochemical gradient for active or passive transport of Na^+ have also been shown to be crucial for plant salinity tolerance [15]. There are also studies published showing that plant salinity tolerance can be achieved through a combination of Na^+ exclusion and tissue tolerance to Na^+ [16]. The results we presented in Chapter 3 support this idea. In Chapter 2 we measured Na^+ and K^+ accumulation in leaves, stems and roots of 93 different tomato accessions and we selected 24 accession based on their different foliar Na^+ accumulation that were thoroughly analysed in Chapter 3. The results of the study reported in Chapter 3 showed that differences in salinity tolerance could not be explained based only on differences in gene expression, but rather on the combination of gene expression and Na^+ tissue tolerance. Results reported in Chapter 3 showed that both tomato “includer” and “excluder” accessions use the same set of genes to cope with salinity. Our results showed a gradient in gene expression of all genes analysed rather than defined groups of accessions according to their salinity tolerance. Although, we obtained several statistically significant correlations between the expression of different genes and between the expression of genes and Na^+ accumulation, we only obtained direct evidence for the role of one transporter involved in Na^+ homeostasis *in planta*, namely HKT1;2. The study of transport activity of HKT1;2 transporters isolated from two different tomato species reported in Chapter 4 showed that differences in transport affinity contribute to differences in Na^+ accumulation in different plant tissues. Moreover, differences in the affinity of HKT transporters have been related to differences in the amino acid sequence of these transporters [17-23]. The results presented in Chapter 4 suggest that the difference in K_m between *S.*

lycopersicum HKT1;2 and *S. pennellii* HKT1;2 might be related to four amino acid differences in the amino acid sequence of these transporters. It would be interesting to replace these four amino acids of one gene by the amino acids presented in the other gene and to study their effect on the transport activity of the mutated transporter. It has been known for long that natural variation present in highly conserved regions within the coding region of genes [7,9,24,25] and promoter regions [26] can be responsible for differences in salinity tolerance. In Chapter 5, we assessed the presence of natural variation in specific regions of the *HKT1;2* coding sequence. These regions were previously shown to be crucial for the functioning of HKT1 transporters in several plant species [4,7,25,27-30]. Although all residues tested showed to be conserved among all tomato accessions studied, some amino acid differences were observed close to our target regions. It is reasonable to assume that more amino acid differences are present in other regions of the *HKT1;2* sequence that were not studied in Chapter 5. Moreover, it is also reasonable to assume that some of these amino acid differences might be responsible for differences in HKT1;2 transport selectivities and affinities. It would be interesting to compare all differences present in the *HKT1;2* coding sequence and promoter of different tomato species to study their possible effects on the transport characteristics and affinity constants of these transporters and, ultimately, correlate these results with Na⁺ accumulation and salinity tolerance. Targeted mutation of amino acids is a well defined strategy [27,28] to study the role of specific amino acids in the functioning of a transporter. The results of heterologous expression of HKT1;2 mutated transporters presented in Chapter 5 showed that in tomato, similar to *Arabidopsis* [28], the replacement of the S residue of the first PD by a G allows the transport of both Na⁺ and K⁺, although with a great reduction in the total currents produced. Interestingly, the presence of both the S70G and K477Q mutation (SIHKT1;2-S70G-K477Q) resulted in currents that were less reduced than the currents produced by SIHKT1;2-S70G, as compared to the currents with the wild-type protein, SIHKT1;2. This “cross-talk” between S70 and K477 might be explained by the close proximity of E75 to the critical first PD amino acid S70. Furthermore, the single or multiple replacements of positively charged amino acids of the M2_D domain by non-charged amino acids resulted in clear reductions of the transport activity leading eventually to the recording of currents not different from those obtained with water-injected oocytes. These results showed how important these residues are in the functioning of the transporter *in planta*, providing a good

explanation for the absence of natural variation. However, these results also raised the question about the significance of results obtained with transporters in heterologous expression systems. Are the results of transporters obtained with heterologous systems of physiological relevance? Or are they of negligible importance *in planta*? [31]. The results presented in Chapter 6 partially answered these two questions. The transformation of *athkt1;1* mutant *Arabidopsis* plants with *AtHKT1;1*, *SlHKT1;1* and *SlHKT1;2* wild type and mutated versions of *AtHKT1;1* and *SlHKT1;2* genes revealed that only *AtHKT1;1* and *SlHKT1;2* wild type genes were able to rescue the mutant phenotype of *athkt1;1* plants. All plant lines expressing mutated versions of *AtHKT1;1* or *SlHKT1;2* or the wild type *SlHKT1;1* did not show any differences in comparison to the *athkt1;1* mutant plants in terms of biomass production and Na⁺ and K⁺ accumulation when treated with 100 mM NaCl for two weeks.

In conclusion, salinity tolerance of tomato plants relies on a complex network of mechanisms. This complex network of mechanisms, rather than one single parameter defines the salinity tolerance of specific tomato accessions.

References

1. Munns R, Tester M (2008) Mechanisms of salinity tolerance. Annual Review of Plant Biology 59: 651-681.
2. Apse MP, Blumwald E (2007) Na⁺ transport in plants. FEBS Letters 581: 2247-2254.
3. Moller IS, Gilliam M, Jha D, Mayo GM, Roy SJ, et al. (2009) Shoot Na⁺ exclusion and increased salinity tolerance engineered by cell type-specific alteration of Na⁺ transport in *Arabidopsis*. Plant Cell 21: 2163-2178.
4. Rus A, Baxter I, Muthukumar B, Gustin J, Lahner B, et al. (2006) Natural variants of AtHKT1 enhance Na⁺ accumulation in two wild populations of *Arabidopsis*. PLoS Genetics 2: 1964-1973.
5. Rus A, Lee BH, Munoz-Mayor A, Sharkhuu A, Miura K, et al. (2004) AtHKT1 facilitates Na⁺ homeostasis and K⁺ nutrition *in planta*. Plant Physiology 136: 2500-2511.
6. Rus A, Yokoi S, Sharkhuu A, Reddy M, Lee BH, et al. (2001) AtHKT1 is a salt tolerance determinant that controls Na⁺ entry into plant roots. Proceedings of the National Academy of Sciences USA 98: 14150-14155.
7. Ali Z, Park HC, Ali A, Oh D-H, Aman R, et al. (2012) TsHKT1;2, a HKT1 homolog from the extremophile *Arabidopsis* relative *Thellungiella salsuginea*, shows K⁺ specificity in the presence of NaCl. Plant Physiology 158: 1463-1474.
8. Plett D, Safwat G, Gilliam M, Moller IS, Roy S, et al. (2010) Improved salinity tolerance of rice through cell type-specific expression of *AtHKT1;1*. PLoS One 5.
9. Ren ZH, Gao JP, Li LG, Cai XL, Huang W, et al. (2005) A rice quantitative trait locus for salt tolerance encodes a sodium transporter. Nature Genetics 37: 1141-1146.
10. Amar SB, Brini F, Sentenac H, Masmoudi K, Very AA (2013) Functional characterization in *Xenopus* oocytes of Na⁺ transport systems from durum wheat reveals diversity among two HKT1;4 transporters. Journal of Experimental Botany: doi:10.1093/jxb/ert1361.

11. Munns R., James RA, Xu B, Athman A, Conn JS, et al. (2012) Wheat grain yield on saline soils is improved by an ancestral Na⁺ transporter gene. *Nature Biotechnology* 30: 360-364.
12. Zhu JK (2001) Plant salt tolerance. *Trends in Plant Science* 6: 66-71.
13. Olias R, Eljakaoui Z, Li J, De Morales PA, Marin-Manzano MC, et al. (2009) The plasma membrane Na⁺/H⁺ antiporter SOS1 is essential for salt tolerance in tomato and affects the partitioning of Na⁺ between plant organs. *Plant Cell and Environment* 32: 904-916.
14. Blumwald E, Aharon GS, Apse MP (2000) Sodium transport in plant cells. *Biochimica et Biophysica Acta* 1465: 140-151.
15. Ashraf M, Akram NA (2009) Improving salinity tolerance of plants through conventional breeding and genetic engineering; An analytical comparison. *Biotechnology Advances* 27: 744-752.
16. Genc Y, McDonald GK, Tester M (2007) Reassessment of tissue Na⁺ concentration as a criterion for salinity tolerance in bread wheat. *Plant, Cell and Environment* 30: 1486-1498.
17. Bagchi R, Salehin M, Adeyemo OS, Salazar C, Shulaev V, et al. (2012) Functional assessment of the *Medicago truncatula* NIP/LATD protein demonstrates that it is a high-affinity nitrate transporter. *Plant Physiology* 160: 906-916.
18. Brown TR, Drummond ML, Barelrier S, Crutchfield AS, Dinescu A, et al. (2011) Aspartate 458 of human glutathione synthetase is important for cooperativity and active site structure. *Biochemical and Biophysical Research Communications* 411: 536-542.
19. Ho CH, Lin HC, Tsay YF (2009) CHL1 functions as a nitrate sensor in plants. *Cell* 138: 1184-1194.
20. Maryon EB, Molloy SA, Ivy K, Yu H, Kaplan JH (2013) Rate and regulation of copper transport by human copper transporter 1 (hCTR1). *The Journal of Biological Chemistry* 288: 18035-18046.
21. Ray SP, Duval N, Wilkinson TG, Shaheen SE, Ghosh K, et al. (2013) Inherent properties of adenylosuccinate lyase could explain S-Ado/SAICAr ratio due to homozygous R426H and R303C mutations. *Biochimica et Biophysica Acta* 1834: 1545-1553.
22. Richards R, Dempsey RE (2012) Re-introduction of transmembrane serine residues reduce the minimum pore diameter of Channelrhodopsin-2. *PLoS One* 7: e50018.
23. Salehin M, Huang YS, Bagchi R, Sherrier DJ, Dickstein R (2013) Allelic differences in *Medicago truncatula* NIP/LATD mutants correlate with their encoded proteins' transport activities in planta. *Plant Signaling and Behaviour* 8: e22813.
24. Cotsaftis O, Plett D, Shirley N, Tester M, Hrmova M (2012) A two-staged model of Na⁺ exclusion in rice explained by 3D modeling of HKT transporters and alternative splicing. *PLoS One* 7: e39865.
25. Baxter I, Brazelton JN, Yu DN, Huang YS, Lahner B, et al. (2010) A Coastal cline in sodium accumulation in *Arabidopsis thaliana* is driven by natural variation of the sodium transporter AtHKT1;1. *PLoS Genetics* 6.
26. Baek D, Jiang JF, Chung JS, Wang BS, Chen JP, et al. (2011) Regulated *AtHKT1* gene expression by a distal enhancer element and DNA methylation in the promoter plays an important role in salt tolerance. *Plant and Cell Physiology* 52: 149-161.
27. Kato N, Akai M, Zulkifli L, Matsuda N, Kato Y, et al. (2007) Role of positively charged amino acids in the M2(D) transmembrane helix of Ktr/Trk/HKT type cation transporters. *Channels* 1: 161-171.
28. Maser P, Hosoo Y, Goshima S, Horie T, Eckelman B, et al. (2002) Glycine residues in potassium channel-like selectivity filters determine potassium selectivity in four-loop-per-subunit HKT transporters from plants. *Proceedings of the National Academy of Sciences USA* 99: 6428-6433.
29. Rubio F, Gassmann W, Schroeder JI (1995) Sodium-driven potassium uptake by the plant potassium transporter HKT1 and mutations conferring salt tolerance. *Science* 270: 1660-1663.

30. Rubio F, Schwarz M, Gassmann W, Schroeder JI (1999) Genetic selection of mutations in the high affinity K^+ transporter HKT1 that define functions of a loop site for reduced Na^+ permeability and increased Na^+ tolerance. *Journal of Biological Chemistry* 274: 6839-6847.
31. Haro R, Banelos MA, Senn MAE, Barrero-Gil J, Rodriguez-Navarro A (2005) HKT1 mediates sodium uniport in roots. Pitfalls in the expression of *HKT1* in yeast. *Plant Physiology* 139: 1495-1506.

Summary

Salinity stress is the most wide-spread and the most severe abiotic stress that plants face. More than 800 million hectares worldwide, representing more than 6% of world's land area, are affected by salinity. Tomato is one of the most important horticultural crops. However, due to the progressive salinization of irrigated land, areas for optimal growth of tomato are being reduced all over the world. To overcome this problem, many attempts have been made to increase the salinity tolerance of tomato using wild tomato species, as these species are a useful source of genes involved in salinity tolerance that can be transferred to cultivated tomato lines.

In order to identify tomato accessions to be used in breeding programmes to develop salinity tolerant tomato lines, in Chapter 2, we treated 93 tomato accessions with NaCl and we measured their Na⁺ and K⁺ tissue concentrations. Our results showed a great variation in ion accumulation between all accessions tested. From the data collected in this Chapter, we selected a group of 24 accessions showing either a high or a low accumulation of Na⁺ in the leaves. This group of accessions was used in a more in depth analysis of salinity tolerance performed in Chapter 3.

The experiments reported in Chapter 3 aimed to find a trait or gene(s) that breeders could use to select for in new breeding programs. In this analysis, we hoped to couple gene expression to variation in levels of ions and organic molecules. In this Chapter, we analysed the expression of several genes directly or indirectly involved in Na⁺ homeostasis *in planta*, such as *HKT*, *SOS*, *NHX*, *LHA* and *AVP*. We also analysed the expression of *P5CS*, a key enzyme in proline biosynthesis. Our results showed that Na⁺, K⁺, Cl⁻, proline and sucrose concentrations did not correlate with salt sensitivity or tolerance. Nevertheless, several significant correlations between the expression of genes and Na⁺ accumulation were observed. For instance, both Na⁺ concentrations in the leaves and stems were positively correlated with *SIHKT1;2* expression in the roots, and Na⁺ concentration measured in the roots correlated positively with *SIHKT1;1* expression also in the roots. These results suggest that Na⁺ exclusion or inclusion and tissue tolerance evolved independently in tomato plants. As a consequence, salinity tolerance can be achieved due to different combinations of Na⁺ accumulations and tissue tolerance in tomato plants.

Based on the HKT expression results obtained in Chapter 3 we decided to analyze more in detail the transport characteristics of tomato HKT transporters. In Chapter 4 we present HKT1;2 protein sequences of *Solanum lycopersicum* and *Solanum pennellii* and provide evidence that both SlHKT1;2 and SpHKT1;2 are Na⁺ transporters. Our kinetic studies showed that SpHKT1;2, in comparison with SlHKT1;2, had a lower affinity for Na⁺. This low affinity of SpHKT1;2 correlated with higher xylem Na⁺ and higher accumulation of Na⁺ in stems and leaves of *S. pennellii*. Our findings demonstrate the importance of the understanding of transport characteristics of HKT1;2 transporters to improve the Na⁺ homeostasis in plants.

In Chapter 5 we analysed whether single nucleotide polymorphisms (SNPs) were present in specific codons of the *HKT* coding sequence. SNPs within the *HKT* coding sequence have been reported to have an important role in the functioning of these transporters. Sequence results showed that all regions tested were conserved among all accessions analysed and SNPs affecting critical amino acids were not found. We also studied the effect of mutations in the HKT sequence on the transport characteristics of these transporters when expressed in *Xenopus laevis* oocytes. Analysis of mutations introduced in the *SlHKT1;2* gene showed that the replacement of S70 by a G allowed SlHKT2;1 to transport K⁺, but at the same time resulted in a large reduction in both Na⁺ and K⁺ mediated currents. Stacking of mutations in positively charged amino acids in the M2_D domain of SlHKT2;1 caused a reduction of Na⁺ mediated currents ultimately leading to a complete loss-of-function. A double mutant of interest was the *SlHKT2;1-S70G-K477Q* mutant that we generated: this protein passes both Na⁺ and K⁺ ions at a reasonable rate.

To test whether transport characteristics of mutated HKT transporters as obtained with *Xenopus* oocytes had physiological importance *in planta*, we transformed *Arabidopsis athkt1;1* mutant plants with several of the mutated *HKT* constructs used in Chapter 5. The results of *Arabidopsis athkt1;1* transformed plants were shown in Chapter 6. The *AtHKT1;1* and *SlHKT1;2* wild type genes complemented the *athkt1;1* mutant growth phenotype. Intriguingly, they fully restored the accumulation of K⁺ in the shoot, whereas they only partially restored the low accumulation of Na⁺ as shown by WT plants. From our observation that complementation of the *athkt1;1* mutant with *HKT* genes, with a single point mutation in the first pore domain, leaves the enhanced Na⁺ and reduced K⁺ accumulation in the shoot unaffected, we concluded

that the AtHKT1;1 protein affects K^+ -loading in the xylem through membrane depolarization rather than through direct interaction with a K^+ -efflux transporter.

In Chapter 7, we provide a literature review on the state of art of HKT transporters. In this Chapter, we review the latest achievements on HKT research and we discuss some remaining research questions.

In conclusion, this thesis illustrates the importance of the study of plant membrane transporters as a way to improve our knowledge on plant salinity tolerance. The knowledge gathered in these studies can provide new tools in plant breeding and in the generation of new commercially important plant lines.

Nederlandse samenvatting

Verzilting is wereldwijd de meest algemene en ernstigste abiotische stress waar planten mee te maken hebben. Meer dan 800 miljoen hectare, wat overeenkomt met 6% van de totale aardoppervlakte, is wereldwijd beïnvloed door zout. Tomaat is een erg belangrijk gewas. Door de wereldwijde toenemende verzilting van het landbouwareaal worden de gebieden die optimaal zijn voor de groei van tomaten steeds kleiner. Om dit probleem te reduceren, zijn er pogingen ondernomen om de zouttolerantie van tomaten te verhogen met behulp van wilde tomatensoorten. Deze wilde tomatensoorten hebben vaak een hogere zouttolerantie dan de gecultiveerde tomatensoorten en kunnen daardoor dienen als nuttige genenbron om de zouttolerantie van gecultiveerde tomatensoorten te verhogen.

In hoofdstuk twee beschrijven we hoe we voor het identificeren van tomatensoorten, met als doel om ze te gebruiken in veredelingsprogramma's, 93 verschillende tomatenvariëteiten blootgesteld hebben aan verschillende zoutconcentraties in hun wortelmilieu en het gehalte aan Na^+ en K^+ in hun weefsels hebben geanalyseerd. Onze resultaten lieten een grote variatie aan zoutaccumulatie tussen de verschillende variëteiten zien. Op basis van deze data hebben we 24 variëteiten geselecteerd—met een hele hoge Na^+ -accumulatie of juist een hele lage Na^+ -accumulatie—om een meer diepgaande analyse op uit te voeren.

In hoofdstuk drie beschrijven we deze diepgaande analyse naar een eigenschap of gen in tomaten hetgeen van nut zou kunnen zijn in nieuwe veredelingsprogramma's met als doel het zouttoleranter maken van de tomaat. We hopen met deze analyse een verband te vinden tussen accumulatie van ionen of bepaalde organische moleculen en genexpressie. We analyseerden de expressie van meerdere genen waarvan bekend was dat ze op een directe of indirecte manier te maken hebben met Na^+ -homeostase in planten. Deze genen waren onder andere *HKT*, *SOS*, *NHX*, *LHA* en *AVP*. We analyseerden ook de expressie van *P5CS*. Onze resultaten lieten zien dat Na^+ -, K^+ -, Cl^- , proline- en sucroseconcentraties niet verschilden tussen zoutgevoelige en zouttolerante tomatenvariëteiten. Desalniettemin vonden we verschillende significante verbanden tussen de expressie van bepaalde genen en Na^+ -concentraties in de plant. Bijvoorbeeld, Na^+ -concentraties in de stengel en in de bladeren waren positief gecorreleerd met de expressie van *SIHKT1;2* in de wortel, en Na^+ -concentraties in de

wortel waren positief gecorreleerd met *SIHKT1;1* in de wortel. Deze resultaten suggereren dat Na⁺-exclusie of -inclusie en weefsel tolerantie onafhankelijk van elkaar zijn geëvolueerd in tomaten. Dit betekent dat zouttolerantie in tomaten kan worden bereikt door verschillende combinaties van cellulaire Na⁺-concentraties en weefsel toleranties.

Gebaseerd op de resultaten van de genexpressie studies, verkregen in hoofdstuk drie, besloten we om de transport karakteristieken van de HKT transporters in tomaten verder te onderzoeken. In hoofdstuk vier beschrijven we de eiwitstructuur van HKT1;2 van *Solanum lycopersicum* en *Solanum pennellii* en dragen we bewijs aan dat zowel SIHKT1;2 en SpHKT1;2 Na⁺-transporters zijn. Onze enzymkinetische experimenten lieten zien dat SpHKT1;2, in vergelijking met SIHKT1;2, een lagere affiniteit voor Na⁺ had. Deze lagere affiniteit van SpHKT1;2 correleerde met een verhoogde Na⁺-concentratie in het xyleem en een verhoogde Na⁺-accumulatie in de stengels en bladeren van *S. pennellii*. Onze resultaten laten zien dat de studie van transportkarakteristieken van de HKT1;2 transporters een belangrijk onderdeel zijn van ons begrip van Na⁺-homeostase in planten.

In hoofdstuk vijf onderzochten we of er single nucleotide polymorphisms (SNPs) aanwezig zijn in bepaalde codons van de HKT coding sequentie. Er bestaan bepaalde SNPs in de HKT coding sequentie waarvan bekend is dat ze een belangrijk effect hebben op het functioneren van deze transporter. Sequencing resultaten lieten zien dat alle regio's die we analyseerden geconserveerde sequenties hadden en dat er geen SNPs waren in belangrijke aminozuren. We bestudeerden ook het effect van mutaties in de HKT coding sequentie op de transportkarakteristieken van deze transporter wanneer we deze tot expressie brachten in *Xenopus leavis* oocyten. Analyse van de mutaties die we introduceerden in het *SIHKT1;2* gen lieten zien dat de vervanging van S70 door een G resulteerde in het transport van K⁺ door SIHKT2;1, en in een sterke reductie van Na⁺ en K⁺ gedragen elektrische stroom. Het stapelen van mutaties in positief geladen aminozuren in het M2_D domein van SIHKT2;1 veroorzaakte een reductie in Na⁺ gerelateerde elektrische stromen en leidde uiteindelijk tot het complete functieverlies van de transporter. Een interessante dubbelmutant die wij genereerden was de *SIHKT2;1-S70G-K477Q* mutant. Deze mutant is in staat om met een redelijke snelheid zowel Na⁺-ionen en K⁺-ionen te transporteren.

Om te onderzoeken of de resultaten die we verkregen met de *Xenopus* oocyten ook een fysiologische betekenis hebben *in planta*, transformeerden we *Arabidopsis*

athkt1;1 mutant met de verschillende gemuteerde *HKT* constructen die we ook gebruikten in hoofdstuk vijf. De resultaten van de transformatiestudies staan beschreven in hoofdstuk 6. De *AtHKT1;1* en *SlHKT1;2* wild-type genen complementeerden het groei fenotype van de *athkt1;1* mutant. Deze genen herstelden ook de accumulatie van K^+ in de scheut, maar herstelden maar gedeeltelijk de lage accumulatie van Na^+ . Uit onze observatie dat de complementatie van de *athkt1;1* mutant met *HKT* genen met een puntmutatie in het eerste transmembraandomein geen effect heeft op de verhoogde Na^+ -accumulatie en verlaagde K^+ -accumulatie in de scheut, concludeerden we dat het AtHKT1;1 eiwit een effect heeft op de K^+ -lading van het xyleem door membraandepolarisatie en niet door een direct effect op de K^+ -transporter.

In hoofdstuk zeven geven we een overzicht van de literatuur van de huidige kennis van HKT transporters. In dit hoofdstuk beschrijven we de laatste ontwikkelingen op het gebied van HKT onderzoek en bediscussiëren we een aantal interessante onderzoeksvragen.

Samengevat, dit proefschrift beschrijft de noodzaak van het onderzoek naar plantmembraantransporters om onze kennis van zouttolerantie in planten te vergroten met als doel om de zouttolerantie in planten uiteindelijk te kunnen verhogen.

Acknowledgements

During my PhD research I came across some challenges and research problems that I only managed to solve with the help of other people. For all help received I would like to say thanks.

First of all, I would like to thank Bert de Boer for giving me the opportunity to do this PhD in his lab. I would like to thank Gert-Jan de Boer for allowing me to spend quite some time performing some experiments at ENZA Zaden in Enkhuizen. I also would like to thank ENZA Zaden for the financial support.

I also want to thank Richard Ferron for all his help with the molecular work and for all the nice talks over a beer, Iris Heidmann for all help with the transformation of *Arabidopsis* and with the GUS experiments, Henry de Groot and Wim van der Knaap for keeping my plants in the greenhouse alive.

I thank also Tijs Bliet for providing and helping me with the Gateway system and Henk Schat for all very constructive discussions about plant physiology.

I thank all people from the Structural Biology Department: Daniel da Costa Pereira, Jing Gao and Henk Hakvoort, Paula van Kleeff for all the help in the lab, especially with gene cloning, and all the nice scientific discussions, Rinse Jaarsma for the nice time we spent in the lab and in de Stelling, and Ingrid for helping me with the oocyte measurements.

A big, big Thank You for my parents and brothers for all your support and understanding.

And last but not least, the biggest Thank You of all to Diana for all the patience and time spent teaching me statistics and reviewing my chapters and all the support and understanding.