

University of Groningen

Design of a manually propelled wheelchair: optimizing a wheelchair-user combination

Vegter, Riemer; de Groot, Sonja; Hettinga, Florentina; Veeger, DirkJan (H. E. J.); van der Woude, L. H. V.

IMPORTANT NOTE: You are advised to consult the publisher's version (publisher's PDF) if you wish to cite from it. Please check the document version below.

Document Version

Publisher's PDF, also known as Version of record

Publication date:

2010

[Link to publication in University of Groningen/UMCG research database](#)

Citation for published version (APA):

Vegter, R., de Groot, S., Hettinga, F., Veeger, D. H. E. J. ., & van der Woude, L. H. V. (2010). Design of a manually propelled wheelchair: optimizing a wheelchair-user combination. (2010 ed.) Center for International Rehabilitation Research Information & Exchange (CIRRIE).

Copyright

Other than for strictly personal use, it is not permitted to download or to forward/distribute the text or part of it without the consent of the author(s) and/or copyright holder(s), unless the work is under an open content license (like Creative Commons).

Take-down policy

If you believe that this document breaches copyright please contact us providing details, and we will remove access to the work immediately and investigate your claim.

Downloaded from the University of Groningen/UMCG research database (Pure): <http://www.rug.nl/research/portal>. For technical reasons the number of authors shown on this cover page is limited to 10 maximum.

International Encyclopedia of Rehabilitation

Copyright © 2010 by the Center for International Rehabilitation Research Information and Exchange (CIRRIE).

All rights reserved. No part of this publication may be reproduced or distributed in any form or by any means, or stored in a database or retrieval system without the prior written permission of the publisher, except as permitted under the United States Copyright Act of 1976.

Center for International Rehabilitation Research Information and Exchange (CIRRIE)
515 Kimball Tower
University at Buffalo, The State University of New York
Buffalo, NY 14214
E-mail: ub-cirrie@buffalo.edu
Web: <http://cirrie.buffalo.edu>

This publication of the Center for International Rehabilitation Research Information and Exchange is supported by funds received from the National Institute on Disability and Rehabilitation Research of the U.S. Department of Education under grant number H133A050008. The opinions contained in this publication are those of the authors and do not necessarily reflect those of CIRRIE or the Department of Education.

Design of a manually propelled wheelchair: optimizing a wheelchair-user combination

Riemer JK Vegter, MSc
Center for Human Movement Sciences, University Medical Center Groningen, University of Groningen, The Netherlands

Sonja de Groot, PhD
Duyvensz-Nagel Research Laboratory, Rehabilitation Centre Amsterdam, The Netherlands
Center for Human Movement Sciences, University Medical Center Groningen, University of Groningen, The Netherlands

Florentina J Hettinga, PhD
Center for Human Movement Sciences, University Medical Center Groningen, University of Groningen, The Netherlands

Dirkjan HJ Veeger, PhD
Faculty of Human Movement Sciences, Institute for Fundamental & Clinical Human Movement Sciences, Vrije Universiteit, Amsterdam, The Netherlands
Man Machine systems, Technical University Delft, The Netherlands

Lucas HV van der Woude, PhD
Center for Human Movement Sciences, University Medical Center Groningen, University of Groningen, The Netherlands
Center for Rehabilitation, University Medical Center Groningen, University of Groningen, the Netherlands

Abstract

Being wheelchair dependent may cause limitations in functioning, i.e. impede functions of daily living (ADL) and/or participation, as is exemplified in the International Classification of Functioning (ICF). To improve ambulation, the wheelchair-user combination can be optimized at three levels. On the level of the user one can optimize physical capacity and technique by training. The second level focuses on the wheelchair-user interface, i.e. the interaction between the human system and the geometry of both the seating orientation and propulsion mechanism, aiming for a higher efficiency. This is operationalized as a better ratio of internal power from the user to the external power required for propulsion. Finally, at the level of the wheelchair the focus lies on minimizing power loss of the wheelchair-user system by reducing frictional forces and optimizing the vehicle mechanics. To advance wheelchair design, better insight in the working mechanisms of our biological system in combination with a mechanical extension, such as the wheelchair, is necessary. Changes to the design need to be theory driven and the research evaluating those changes is of great importance and needs to be available. Ongoing development of research and research methods allows for better insight and better design as well as wheelchair prescription today.

Introduction

Numerous persons are dependent on a manually propelled wheelchair for their mobility. In the Netherlands for instance, approximately 82 percent of individuals with spinal cord injury (SCI), admitted for inpatient rehabilitation, are wheelchair users (Post and others 1997). Being dependent on a wheelchair for mobility may cause limitations in functioning, i.e. impede functions of daily

living (ADL) and/or participation, as is exemplified in the International Classification of Functioning (ICF) (WHO 2001). In figure 1 the ICF model of human functioning and disability is presented, adapted to persons with SCI. The model shows that activities and participation are influenced by the impairment, and by both personal (internal) factors and environmental (external) factors. In this model the use of assistive technology, such as a wheelchair, is part of the external factors that influence mobility and more importantly, the functioning and participation of the wheelchair user. A recent study showed that wheelchair mobility influences participation, peak aerobic power output, and wheelchair skill performance, all of which are significant predictors of return to work for a group of wheelchair dependent persons with SCI one year after discharge from inpatient rehabilitation (van Velzen and others 2009).

Despite its importance manual wheelchair propulsion is a straining form of ambulation. Unlike the hip joint the function of the shoulder complex is more oriented towards joint mobility at the cost of a lower stability, requiring considerable muscular effort for stability control (Veeger and van der Helm 2007). Furthermore the upper body has limited work capacity, due to a small (untrained) muscle mass, which leads to high levels of relative mechanical and cardio-respiratory strain during daily life (ADL) (Janssen and others 1997). The long-term consequence of a continued mismatch between the stress of daily wheeling, the physical strain and the overall physical wheelchair capacity causes serious secondary health problems, the most important being overuse problems in the upper extremities (Boninger and others 2005; Curtis and others 1999; Sawatzky and others 2005; van Drongelen and others 2006) which may lead to chronic impairments and pain. Upper extremity overuse problems are estimated to be present after 10-15yrs of wheelchair use among 50-70% of the wheelchair user population with a SCI (Nichols and others 1979). In addition, physical strain, fatigue and even (temporary) pain, affects wheelchair use and daily activity patterns. Inactivity may emerge, which in turn may deteriorate physical work capacity, and lead to a downward spiral of deconditioning. This may introduce overweight and obesity, and general chronic health problems such as diabetes, metabolic syndrome and cardiovascular problems in the long term, as well as secondary impairments such as decubitus and urinary tract infections (Haisma and others 2007; Noreau and others 2000).

Part of the physical strain of wheelchair use on the user is caused by the low efficiency of handrim propulsion (de Groot and others 2007; de Groot and others 2008; Hintzy and Tordi 2004; Veeger and others 1992). Only 6-11% of the internally liberated energy actually goes to effective propulsion of the wheelchair. Well-trained wheelchair athletes may get efficiencies up to 18% in a racing wheelchair (Cooper and others 2003). However, these values are still lower compared to lower extremity activities such as cycling (20-25%) (Ettema and Loras 2009). To improve efficiency, alterations in wheelchair design and set-up are imperative and one has to deal with the user-wheelchair combination as a whole, as well as on its different components. Therefore, the HAAT model (Cook and Hussey 2002), which describes the interaction between human (H), activity (A) and assistive technology (AT) in the environment is instructive. Thus, optimizing the wheelchair-user combination must be achieved by adjusting any or a combination of the following elements: the user, the wheelchair-user interface and the wheelchair (figure 2). This article will give a short overview of the practical implications of the research developments regarding these aspects over the last decades and will take a look forward at the research requirements for further design improvements in the near future.

User

There is no single ultimate design in general, but there is always a design that is adjusted to the user. It is important to understand the possibilities and needs of the user to adequately design and fit the correct wheelchair. Physical characteristics such as upper-extremity muscle force and peak power output have been shown to closely relate with wheelchair skill performance (Kilkens and

The hand rim radius is, in fact, a gearing level (van der Woude and others 1988; Veeger and others 1992). Smaller hand rims (figure 3a) will require a larger propulsion force and lower hand velocity at a given travelling speed. Different task conditions will require different radii i.e. gearing levels:

While considering the interface the first thing that comes to mind is the handrim, since this is where the coupling between the biological system and the wheelchair takes place. Regarding the handrim there are several design options; the handrim radius, the angle under which it is placed (camber), the diameter, surface material and shape of the tube. An additional aspect to be considered is the use of gloves, that is, changing the handrim-hand interface. This is a common feature in certain wheelchair sports (i.e. quad rugby) and may help to optimize functioning (Mason and others 2009).

Handrim

Power production is not only determined by the user but also depends on the interaction of the human system with the form and geometry of the propulsion mechanism and the seat configuration; therefore design of a proper interface is of importance (van der Woude and others 2001b). Experiments focusing on the interface have proven the possible role of optimization of interfacing on propulsion technique, efficiency and peak power output. Apart from different propulsion mechanisms (levers, cranks etc), possible design venues are handrim characteristics and seat-position. Both aspects will briefly be discussed here, together with a short sidestep to alternative propulsion mechanisms.

Wheelchair-user interface

Another important user-related aspect is that of motor skill learning, since rehabilitation involves learning the new task of propelling the wheelchair. Propelling the wheelchair takes more than being physically able to exert a certain amount of power; correct coordination patterns will for a larger part determine functioning of any wheelchair-user combination and is expressed in a higher mechanical efficiency. Positive effects of low-intensity training were shown on mechanical efficiency, metabolic cost and the propulsion technique of inexperienced able-bodied participants (de Groot and others 2008; de Groot and others 2003). This shows that even without adaptations to the interface or wheelchair it is still possible to obtain a higher efficiency with training. To optimize training, knowledge of motor learning and insight in proper propulsion techniques is of the utmost importance. For instance only recently it was shown that training a person to push as tangentially to the circle of the handrim as possible does not improve efficiency, as has been speculated in the past (Bregman and others 2009; de Groot and others 2002).

The physical capacity varies widely between users and these inter-individual differences impact the design of a wheelchair. Knowledge of the peak power output of a person can give a good indication of how intensive it is for him/her to propel a wheelchair. A recent study of Haisma et al. (Haisma and others 2006) reports on the large differences in peak power output, measured in a wheelchair, of persons with tetraplegia (mean: 26 W) and paraplegia (mean: 74 W) during inpatient rehabilitation. If we combine this knowledge with research of Van der Woude et al. (van der Woude and others 1999) on wheelchair rolling resistance of different floor surfaces we can get some insight into the clinical impact of these values. For instance vinyl as found in a gym of a rehabilitation center had a rolling resistance for a certain wheelchair of ca. 20 N. At a speed of 4 km/h this takes a power output of 22 W, which is 85% of the peak power output for the person with tetraplegia, while only 30% for persons with paraplegia. This example stresses the need for a different view on design for different user groups. Besides design, training physical capacity of the user has proven its worth and is of great importance to improve mobility (Killicks and others 2005b). A higher peak power output will reduce the relative strain of daily wheeling. In this perspective a physically active lifestyle is important since 'exercise is medicine' (<http://www.exercisemedicine.org>).

groups of well-trained subjects may want a gearing which enables them to compete at high velocities, whereas a steep incline for physically less able subjects will demand a low gear. A study on the use of a handrim with two gears incorporated in the wheel (figure 3b) found pain reductions within 2 weeks after the participants started using the device, thus indicating the potential for shoulder pain reduction by the use of different gears (Finley and Rodgers 2007). In line with these findings the use of an electromotor in the wheel hub, which only aids in the propulsion when the user exerts force on the handrim, can be of use. Such hand-rim activated power assisted wheelchairs aid the user who can no longer cope with the strain on the upper limbs during manual wheelchair propulsion. Compared to standard handrim propulsion, such a device lowers the overall cardiorespiratory strain and shoulder muscle activity (Lighthall-Haubert and others 2009), and yet allows the user to be an active participant in society.

The second design possibility does not solely relate to the rim, but to the wheel as a whole. Camber in the rear wheels places the handrim under a certain angle to the user. The positive effect of camber on stability of the wheelchair user system is relevant (Trudel and others 1997). Furthermore the hands are protected when passing along objects because the width at the base of the wheelchair is larger than at the height of the hands (Veeger and others 1989). Beside the positive effects on stability, hand comfort on the push rims and maneuverability, changes of camber do not seem to be associated with changes in efficiency of wheelchair propulsion (Perdios and others 2007).

In addition to the radius of the rim the diameter of the tube, its shape and the use of different materials is of importance. A conventional handrim tube is a 19 mm diameter circle; new alternatives have been developed to make a better interface between hand and wheel. Modifications have to do with the shape of the tube and the attachment to the wheel (figure 4). A recent study between four different handrims with respect to shape and material in able-bodied subjects did not find significant effects on any of the physiological parameters and force application characteristics (van der Woude and others 2003). On the other hand two other specific handrim designs were found to be beneficial and are currently commercially available. First the Flexrim, a flexible handrim (figure 4a) that allows some freedom of movement between handrim and wheel showed significant reductions in both peak and total forearm muscle activation. The flexible handrim required less finger and wrist flexor activity than a standard uncoated handrim for the same propulsion conditions (Richter and others 2006).

Second the use of the Natural-Fit contoured handrim (figure 4b) was surveyed among its users. This handrim has a larger oval shape than the conventional 19 mm circle and uses different materials for the place of the thumb and finger. The majority of participants reported improvements in upper-extremity symptoms, ease of wheelchair propulsion, and functional status (Dieruf and others 2008). The possible benefits of a larger oval shape as in the Natural-fit handrim were also reported earlier by van der Linden et al (van der Linden and others 1996).

Seat height and position in the chair

Besides the connection between the hand and the wheel, the body position with respect to the wheel axle influences propulsion. Van der Woude et al. (van der Woude and others 2009) operationalized seat height as the elbow angle while sitting in the wheelchair with hand on top dead centre of the wheel. In their research they found a tendency for mechanical efficiency and mechanical strain to optimize seat height at an elbow angle of 100–130° in persons with a spinal cord injury during rehabilitation.

Cowan et al (Cowan and others 2009) used this angle to maintain seat height and studied two different horizontal axle positions. Their findings suggest more anterior axle positions to be beneficial in reducing peak resultant forces exerted by the hand on the rim. Yet this position of the

The second contributor to the frictional forces is air resistance. At high velocity like in wheelchair racing this factor is by far the most important source of energy loss. Air resistance is dependent on the drag coefficient, frontal plane area, air density and velocity of the airflow relative to the object. Air resistance will be of minor importance at low speeds, but at high speeds and/or wind velocities air resistance will be the most important source of resistance. Following Abel and Frank (Abel and Frank 1991), at slow speed (3.6 km/h) air drag will be below 1 N, while at 18 km/h the drag force

Air resistance

The magnitude of the friction is related to the amount of deformation of tire and floor surface (van der Woude and others 1999). This deformation dissipates energy (Kauzlarich and Thacker 1985). Deformation is dependent on tire pressure, tread and profile, wheel diameter, and also on wheel alignment, mass of the wheelchair and the user, and of course, the surface on which one wheels.

Rolling resistance

If a wheelchair is kept at a constant speed, the wheelchair user has to produce a certain amount of energy per unit time, or power. With each push work is produced and the product of work and push frequency equals the mean power produced by the user. This so-called external power is produced by the user, but requires a much higher amount of internal power. The external power output is necessary to overcome energy losses in the system and the environment. The wheelchair-user combination will lose energy in the form of rolling resistance, air resistance and internal resistance in the mechanical structures of the chair. When more external power is produced than needed to overcome these losses, the chair will accelerate. In the following the different contributors to power loss will be briefly discussed, since they will determine for the larger part the experienced strain of wheeling. The main message is that these external forces must be minimized through wheelchair design improvements and maintenance, as well as through environmental changes.

Wheelchair

Handbikes and other forms of propulsion, like hubcranking or lever mechanisms (figure 5), are found to have better efficiencies than handrim propulsion (van der Woude and others 2001a). Overall the limited muscle mass and function of the upper body are more cautiously and effectively used in levers or cranks as opposed to the handrim. Especially handbikes are a good alternative for outdoor wheeling, sports and recreation, given their higher efficiency (van der Woude and others 2008). Certain drawbacks like maneuverability, and added width and weight make these devices especially useful outdoors. These new developments have an effect on the use of the handrim wheelchair. Through the years the use of the handrim wheelchair has proven itself and as such shall probably not be replaced for most ADL tasks. Apart from fine-tuning one needs to consider the task specific use of handrim wheelchairs as is typically done in different sports disciplines. The handrim-propelled wheelchair can be seen as the walking means of the wheelchair user and should be optimized towards that goal. This shift in use should be reflected in the design.

Other propulsion mechanisms

axle leads to a lower rolling resistance confounding possible interface effects. Another investigation on the relation of wrist kinematics and horizontal position did not find effect on wrist kinematics for horizontal displacement (Wei and others 2003). Kotajarvi et al (Kotajarvi and others 2004) studied both vertical and horizontal changes of the wheel axes, they only found vertical changes e.g. changes in seat height to be of influence. It can be concluded that the effect of seat height is clear, while horizontal changes of the axle still need to be better understood. Furthermore, changes in seat to backrest angle and system tilt angle were analyzed (Desroches and others 2006) but were found not to be of effect in shoulder average and peak moments, and can be optimized towards other goals such as comfort and pressure modulation.

due to air resistance is ± 14 N, which implies an average power output of 70W for wind resistance only at that wheelchair speed. It is obvious that the frontal plane area is dependent on the posture of the user. Although a wind tunnel experiment has been performed (Coe 1979) as well as empirical measurements (Hedrick and others 1990; Higgs 1992), no recent figures on air resistance have been published in association with contemporary wheelchair sitting posture and propulsion technique. However, from hand cycling or speed skating many new developments were transferred to wheelchair racing. Next to frontal area reduction, adaptation of the seat position and orientation of the segments of the body, and the application of skin suits will influence the drag coefficient.

Internal friction

Energy losses within the wheelchair are caused by bearing friction around the wheel axles and in the wheel suspension of the castor wheels and possibly by the deformation of the frame in folding wheelchairs during the force exertion in the push phase. Bearing friction generally is very small, and given that the hubs have annular bearings and are well maintained and lubricated, this friction coefficient will not exceed 0 (Frank and Abel 1993). However, the losses in ill-maintained bearings can be considerable.

An unknown aspect of internal energy dissipation is the loss of propulsion energy due to deformation of the frame elements. This will clearly be possible in folding wheelchairs, but has not been addressed empirically. The use of levers and cranks does introduce a chain, chain wheel and gearbox related friction. Whitt and Wilson (Whitt and Wilson 1982) indicate a possible loss of energy of 1.5% in chain transmission.

Slope and acceleration

Although body mass and wheelchair mass have a small effect on rolling resistance, they have a considerable effect on the slope component and the acceleration component. Acceleration potential is inversely related to total mass at a given power output (acceleration will be slower when the mass of the system is larger). Also, mass is linearly related to power output in climbing. Of course, this extra investment will be returned partially during descents, but will still lead to higher losses. Wheelchair mass can be influenced through proper technology and lightweight materials. Important to realize though is that the major attributor to the total mass is the mass of the user. On the other hand, besides reducing mass for propulsion purposes it is also good to note the amount of times a wheelchair needs to be picked up, for instance, to get in a car; here reduced mass of the wheelchair will be of great benefit.

Evaluation of wheelchair design

Cooper (Cooper 2009b) stated: "The greatest engineering challenges in manual wheelchair design are optimizing interaction between the user and the wheelchair, which requires knowledge of materials, biomechanics, ergonomics, anthropometrics and human physiology, as well as motor learning to train the user in the skills necessary to achieve maximum mobility." If one is to gain knowledge of the above-named fields research possibilities need to be available. Developments of research tools have made it possible to advance in experimental setup towards the use of a manual wheelchair. For instance an instrumented wheel (SMARTwheel or Optipush) (figure 6) that measures three dimensional forces and moments, together with the angle of the wheel (Cooper 2009a). Knowledge of these forces combined with position registration of important anatomical positions can be used as input for an inverse-dynamic model that calculates net moments around the human joints, as well as internal load, using a detailed shoulder-arm model (van der Helm and Veeger 1996). Furthermore the measurement of oxygen uptake is used to estimate metabolic power and thus calculate efficiency. Electromyography (EMG) can give more insight in muscle activation, like identifying co-contractions. Important note is that technological developments can only

Although handrim wheelchair propulsion has been the focus of quite some research it is not yet fully understood, therefore its design cannot yet be fully optimized. Major issues concern efficiency and shoulder overuse. In the future development in materials and production technique can help in improving the design. Moreover advances in research methods to get an insight into the working of our biological system in combination with assistive technology might provide better solutions to optimize mobility in terms of efficiency and preservation of the physical capacity of the user over time.

Conclusion

attribute to design if they are used to address the proper questions. The link between technology and design needs to be made by proper theory-driven research to give insight in new design venues towards better functioning.

Figures

Figure 1: The international classification of functioning, disability and Health as developed by the World Health Organisation and applied to persons with a SCI (WHO 2001).

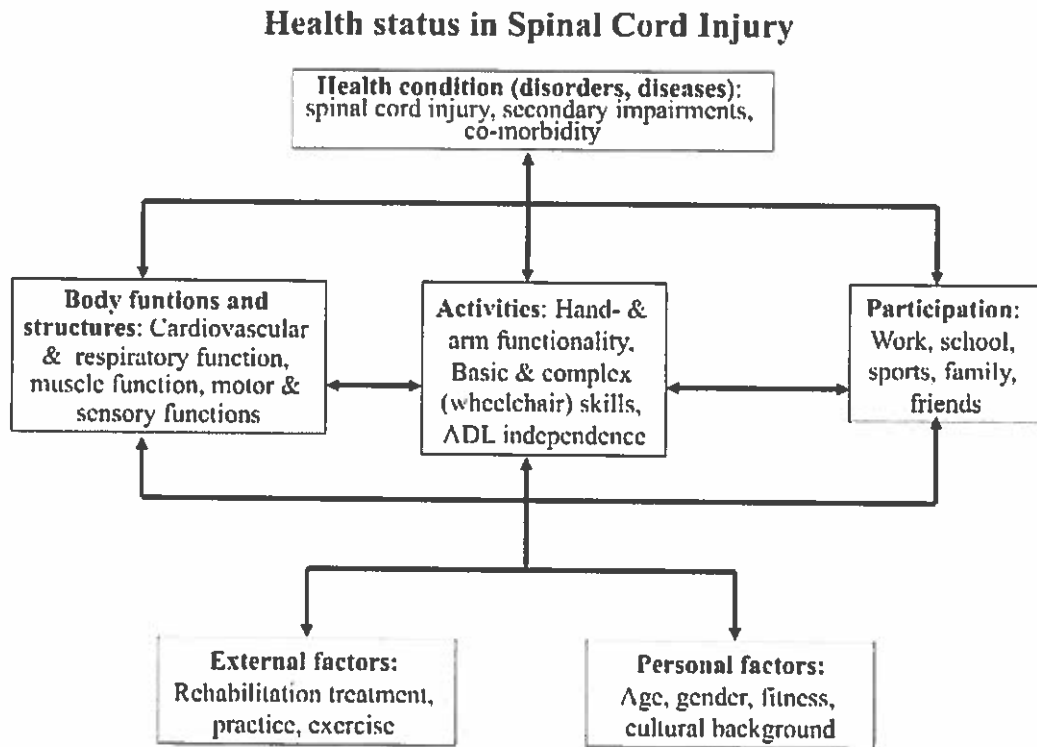
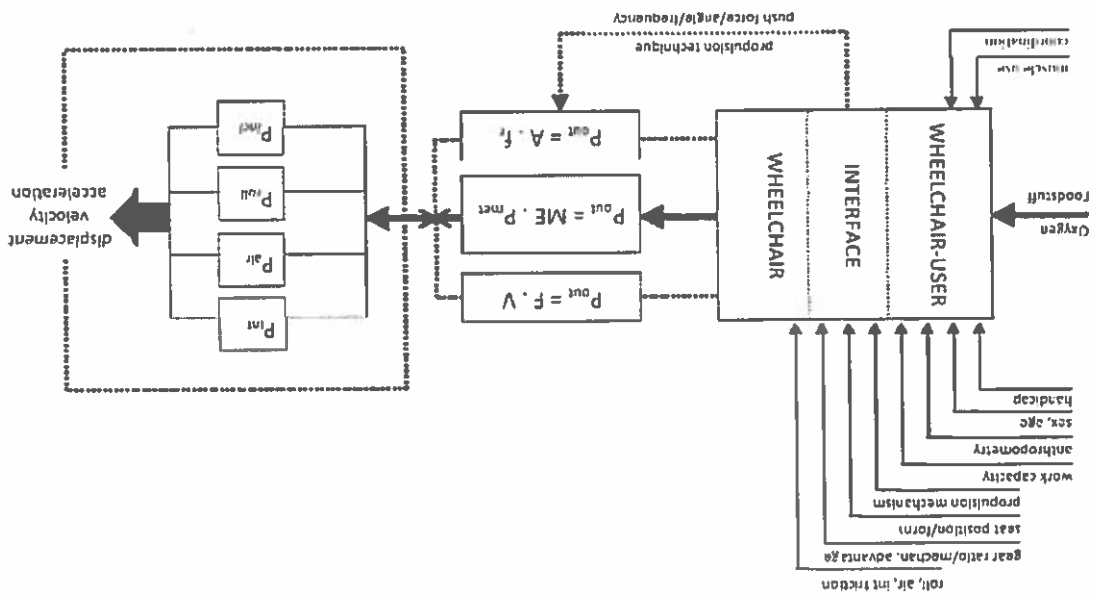

Figure 2: Factors influencing power generation (P_{out}) and energy transfer in manual wheelchair propulsion (van der Woude and others 1986).



With: power output (P_{out} (W)), force (F (N)), velocity (V (m/s)), mechanical efficiency (ME), Metabolic power (P_{met} (W)), work per cycle (A (Nm)), cycle frequency (f_{tr} (Hz)), power lost internally (P_{int} (W)), power loss due to air resistance (P_{air} (W)), power loss due to rolling resistance (P_{roll} (W)) and power loss due to inclination (P_{incl} (W))

Figure 3: Different gearing and rim sizes (a) an athletic and a normal handrim (b) Magic wheels, a 2-gear wheel (www.magicwheels.com)

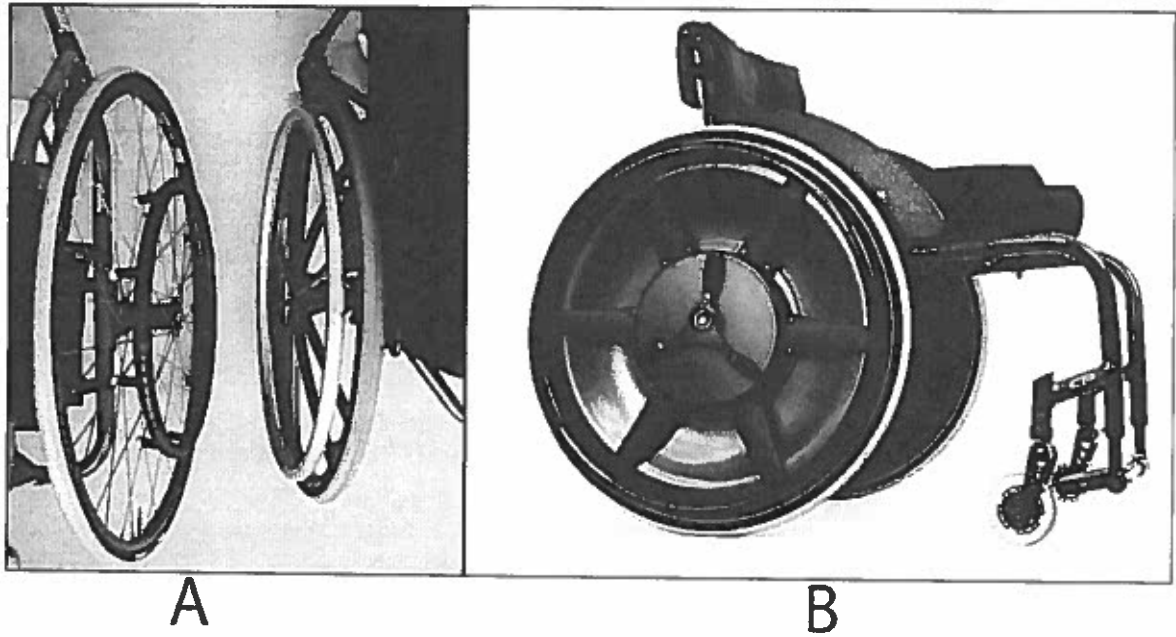
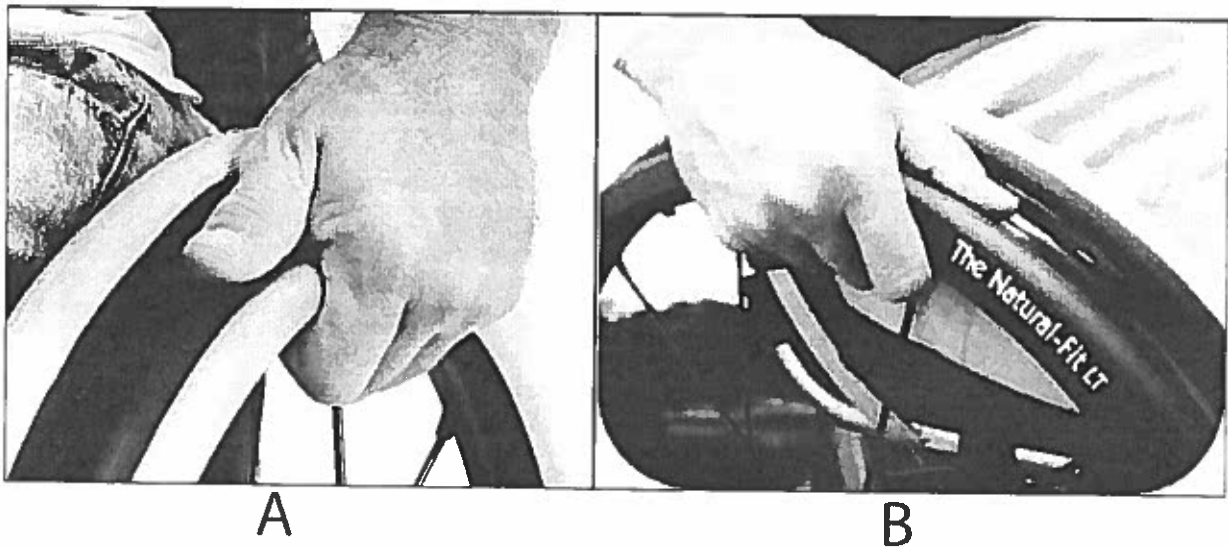

Figure 4: Different handrim tube shapes, (a) Flexrim (www.flexrim.com) (b) Natural-fit handrim (www.3rivers.com)



Boninger ML, Koontz AM, Sisto SA, Dyson-Hudson TA, Chang M, Price R, Cooper RA. 2005. Pushrim biomechanics and injury prevention in spinal cord injury: recommendations based on CULP-SCI investigations. *Journal of Rehabilitation Research and Development* 42:9-19.

Bregman DJ, van Drongeelen S, Veeger HE. 2009. Is effective force application in handrim wheelchair propulsion also efficient? *Clinical Biomechanics* (Bristol, Avon) 24:13-9.

References

Abel EW, Frank TG. 1991. The design of attendant propelled wheelchairs. *Prosthetics and Orthotics International* 15:38-45.

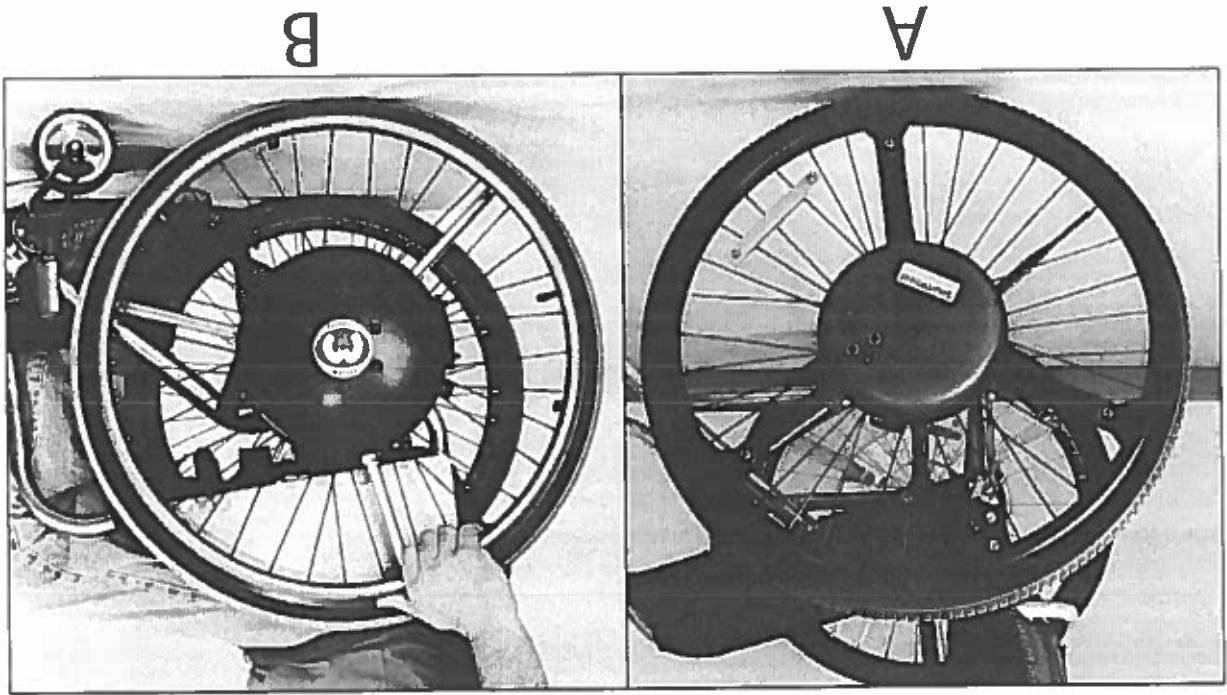

Figure 6: Two ambulant 3D force measurement devices: (a) SmartWheel (www.3rivers.com), (b) the Optipush (www.max-mobility.com).

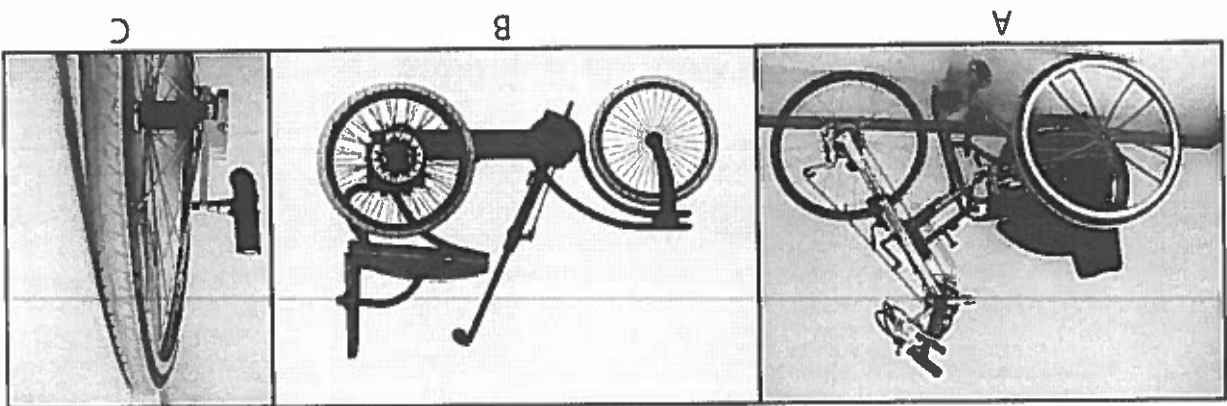

Figure 5: Alternative propulsion mechanisms: (a) handcycle, (b) RoTrike, a lever propelled tricycle (www.rotamobility.com), (c) hubcrank wheel.

- Coe PL. 1979. Aerodynamics characteristics of wheelchairs. NASA Technical Memorandum 80191:1-17.
- Cook A, Hussey S. 2002. Assistive Technologies - Principles and Practices. 2nd ed. Mosby.
- Cooper RA. 2009a. SMARTWheel: From concept to clinical practice. *Prosthetics and Orthotics International* 33:198-209.
- Cooper RA. 2009b. Wheeled mobility and manipulation technologies. *The Bridge* 39.
- Cooper RA, Boninger ML, Cooper R, Robertson RN, Baldini FD. 2003. Wheelchair racing efficiency. *Disability and Rehabilitation* 25:207-12.
- Cowan RE, Nash MS, Collinger JL, Koontz AM, Boninger ML. 2009. Impact of surface type, wheelchair weight, and axle position on wheelchair propulsion by novice older adults. *Archives of Physical Medicine and Rehabilitation* 90:1076-83.
- Curtis KA, Tyner TM, Zachary L, Lentell G, Brink D, Didyk T, Gean K, Hall J, Hooper M, Klos J, et al. 1999. Effect of a standard exercise protocol on shoulder pain in long-term wheelchair users. *Spinal Cord* 37:421-9.
- de Groot S, Dallmeijer AJ, van Asbeck FW, Post MW, Bussmann JB, van der Woude L. 2007. Mechanical efficiency and wheelchair performance during and after spinal cord injury rehabilitation. *International Journal of Sports Medicine* 28:880-6.
- de Groot S, de Bruin M, Noomen SP, van der Woude LH. 2008. Mechanical efficiency and propulsion technique after 7 weeks of low-intensity wheelchair training. *Clinical Biomechanics (Bristol, Avon)* 23:434-41.
- de Groot S, Veeger HE, Hollander AP, van der Woude LH. 2002. Consequence of feedback-based learning of an effective hand rim wheelchair force production on mechanical efficiency. *Clinical Biomechanics (Bristol, Avon)* 17:219-26.
- de Groot S, Veeger HE, Hollander AP, van der Woude LH. 2003. Adaptations in physiology and propulsion techniques during the initial phase of learning manual wheelchair propulsion. *American Journal of Physical Medicine & Rehabilitation* 82:504-10.
- Desroches G, Aissaoui R, Bourbonnais D. 2006. Effect of system tilt and seat-to-backrest angles on load sustained by shoulder during wheelchair propulsion. *Journal of Rehabilitation Research and Development* 43:871-82.
- Dieruf K, Ewer L, Boninger D. 2008. The natural-fit handrim: factors related to improvement in symptoms and function in wheelchair users. *Journal of Spinal Cord Medicine* 31:578-85.
- Ettema G, Loras HW. 2009. Efficiency in cycling: a review. *European Journal of Applied Physiology* 106:1-14.
- Finley MA, Rodgers MM. 2007. Effect of 2-speed geared manual wheelchair propulsion on shoulder pain and function. *Archives of Physical Medicine and Rehabilitation* 88:1622-7.
- Frank TG, Abel EW. 1993. Drag forces in wheelchairs. In *Ergonomics of manual wheelchair propulsion: state of the art*. In: L van der Woude, P Meijjs, VD Grinten, D Boer, editors. Amsterdam: IOS Press.

- Haisma JA, van der Woude LH, Stam HJ, Bergen MP, Sluis TA, Bussmann JB. 2006. Physical capacity in wheelchair-dependent persons with a spinal cord injury: a critical review of the literature. *Spinal Cord* 44:642-52.
- Haisma JA, van der Woude LH, Stam HJ, Bergen MP, Sluis TA, Post MW, Bussmann JB. 2007. Complications following spinal cord injury: occurrence and risk factors in a longitudinal study during and after inpatient rehabilitation. *Journal of Rehabilitation Medicine* 39:393-8.
- Hedrick B, Wang YT, Moenizadah M, Adrian M. 1990. Aerodynamic positioning and performance in wheelchair racing. *Adapted Physical Activity Quarterly* 7:41-51.
- Higgs C. 1992. Wheeling in the wind: the effect of wind velocity and direction on aerodynamic drag of wheelchairs. *Adapted Physical Activity Quarterly* 9:74-87.
- Hintzy F, Tordi N. 2004. Mechanical efficiency during hand-rim wheelchair propulsion: effects of base-line subtraction and power output. *Clinical Biomechanics (Bristol, Avon)* 19:343-9.
- Janssen TW, van Oers CA, van Kamp GJ, TenVoerde BJ, van der Woude LH, Hollander AP. 1997. Coronary heart disease risk indicators, aerobic power, and physical activity in men with spinal cord injuries. *Archives of Physical Medicine and Rehabilitation* 78:697-705.
- Kauzlarich JJ, Thacker JG. 1985. Wheelchair tire rolling resistance and fatigue. *Journal of Rehabilitation Research and Development* 22:25-41.
- Kilkens OJ, Dallmeijer AJ, Nene AV, Post MW, van der Woude LH. 2005a. The longitudinal relation between physical capacity and wheelchair skill performance during inpatient rehabilitation of people with spinal cord injury. *Archives of Physical Medicine and Rehabilitation* 86:1575-81.
- Kilkens OJ, Post MW, Dallmeijer AJ, van Asbeck FW, van der Woude LH. 2005b. Relationship between manual wheelchair skill performance and participation of persons with spinal cord injuries 1 year after discharge from inpatient rehabilitation. *Journal of Rehabilitation Research and Development* 42:65-73.
- Kotajarvi BR, Sabick MB, An KN, Zhao KD, Kaufman KR, Basford JR. 2004. The effect of seat position on wheelchair propulsion biomechanics. *Journal of Rehabilitation Research and Development* 41:403-14.
- Lighthall-Haubert L, Requejo PS, Mulroy SJ, Newsam CJ, Bontrager E, Gronley JK, Perry J. 2009. Comparison of shoulder muscle electromyographic activity during standard manual wheelchair and push-rim activated power assisted wheelchair propulsion in persons with complete tetraplegia. *Archives of Physical Medicine and Rehabilitation* 90:1904-15.
- Mason BS, van der Woude LH, Goosey-Tolfrey VL. 2009. Influence of glove type on mobility performance for wheelchair rugby players. *American Journal of Physical Medicine & Rehabilitation* 88:559-70.
- Nichols PJ, Norman PA, Ennis JR. 1979. Wheelchair user's shoulder? Shoulder pain in patients with spinal cord lesions. *Scand Journal of Rehabilitation Medicine* 11:29-32.
- Noreau L, Proulx P, Gagnon L, Drolet M, Laramée MT. 2000. Secondary impairments after spinal cord injury: a population-based study. *American Journal of Physical Medicine & Rehabilitation* 79:526-35.

- Perdios A, Sawatzky BJ, Sheel AW. 2007. Effects of camber on wheeling efficiency in the experienced and inexperienced wheelchair user. *Journal of Rehabilitation Research and Development* 44:459-66.
- Post MW, van Asbeck FW, van Dijk AJ, Schrijvers AJ. 1997. Services for spinal cord injured: availability and satisfaction. *Spinal Cord* 35:109-15.
- Richter WM, Rodriguez R, Woods KR, Karpinski AP, Axelson PW. 2006. Reduced finger and wrist flexor activity during propulsion with a new flexible handrim. *Archives of Physical Medicine and Rehabilitation* 87:1643-7.
- Sawatzky BJ, Slobogean GP, Reilly CW, Chambers CT, Hol AT. 2005. Prevalence of shoulder pain in adult- versus childhood-onset wheelchair users: a pilot study. *Journal of Rehabilitation Research and Development* 42:1-8.
- Trudel G, Kirby RL, Ackroyd-Stolarz SA, Kirkland S. 1997. Effects of rear-wheel camber on wheelchair stability. *Archives of Physical Medicine and Rehabilitation* 78:78-81.
- van der Helm FC, Veeger HE. 1996. Quasi-static analysis of muscle forces in the shoulder mechanism during wheelchair propulsion. *Journal of Biomechanics* 29:39-52.
- van der Linden ML, Valent L, Veeger HE, van der Woude LH. 1996. The effect of wheelchair handrim tube diameter on propulsion efficiency and force application (tube diameter and efficiency in wheelchairs). *IEEE Transactions on Neural and Rehabilitation Systems Engineering* 4:123-32.
- van der Woude LH, Bouw A, van Wegen J, van As H, Veeger D, de Groot S. 2009. Seat height: effects on submaximal hand rim wheelchair performance during spinal cord injury rehabilitation. *Journal of Rehabilitation Medicine* 41:143-9.
- van der Woude LH, Dallmeijer AJ, Janssen TW, Veeger D. 2001a. Alternative modes of manual wheelchair ambulation: an overview. *American Journal of Physical Medicine & Rehabilitation* 80:765-77.
- van der Woude LH, de Groot G, Hollander AP, van Ingen Schenau GJ, Rozendal RH. 1986. Wheelchair ergonomics and physiological testing of prototypes. *Ergonomics* 29:1561-73.
- van der Woude LH, Formanoy M, de Groot S. 2003. Hand rim configuration: effects on physical strain and technique in unimpaired subjects? *Medical Engineering & Physics* 25:765-74.
- van der Woude LH, Horstman A, Faas P, Mechielsen S, Bafghi HA, de Koning JJ. 2008. Power output and metabolic cost of synchronous and asynchronous submaximal and peak level hand cycling on a motor driven treadmill in able-bodied male subjects. *Medical Engineering & Physics* 30:574-80.
- van der Woude LH, Veeger HE, Dallmeijer AJ, Janssen TW, Rozendaal LA. 2001b. Biomechanics and physiology in active manual wheelchair propulsion. *Medical Engineering & Physics* 23:713-33.
- van der Woude LH, Veeger HE, Rozendal RH, van Ingen Schenau GJ, Rooth F, van Nierop P. 1988. Wheelchair racing: effects of rim diameter and speed on physiology and technique. *Medical Engineering & Physics* 20:492-500.

- van der woude LHV, Guerts C, Winkelman H, Veeger HEJ. 1999. Measurement of rolling resistance with a push technique. In Biomedical aspects of manual wheelchair propulsion: state of the art II. In: LHV van der woud, MTE Hopman, C van Kemnade, editors. Amsterdam: IOS Press.
- van Drongeelen S, de Groot S, Veeger HE, Angenot EL, Dallmeijer AJ, Post MW, van der Woude LH. 2006. Upper extremity musculoskeletal pain during and after rehabilitation in wheelchair-using persons with a spinal cord injury. *Spinal Cord* 44:152-9.
- van Velzen JM, de Groot S, Post MW, Slootman JH, van Bennekom CA, van der Woude LH. 2009. Return to work after spinal cord injury: is it related to wheelchair capacity at discharge from clinical rehabilitation? *American Journal of Physical Medicine & Rehabilitation* 88:47-56.
- Veeger D, van der Woude LH, Rozendal RH. 1989. The effect of rear wheel camber in manual wheelchair propulsion. *Journal of Rehabilitation Research and Development* 26:37-46.
- Veeger HE, van der Helm FC. 2007. Shoulder function: the perfect compromise between mobility and stability. *Journal of Biomechanics* 40:2119-29.
- Veeger HE, van der Woude LH, Rozendal RH. 1992. Effect of handrim velocity on mechanical efficiency in wheelchair propulsion. *Medical Engineering & Physics* 24:100-7.
- Wei SH, Huang S, Jiang CJ, Chiu JC. 2003. Wrist kinematic characterization of wheelchair propulsion in various seating positions: implication to wrist pain. *Clinical Biomechanics* (Bristol, Avon) 18:S46-52.
- Whitt FR, Wilson DG. 1982. *Bicycling science*. MIT press.
- WHO. 2001. *International Classification of Functioning, Disability and Health*. Geneva: World Health Organisation.