

Analog RFI Detectors for Microwave Radiometers

Presenting Author

Joseph Knuble

NASA's Goddard Space Flight Center

Microwave Instrument and Technology Branch, Code 555

Greenbelt, MD 20771

USA

Microwave radiometers use radio spectrum dedicated to sensing the environment. As wireless communications and other active services proliferate, this allocated spectrum is nearly being crowded out. The potential result is corrupted satellite measurements of the weather, the climate, and the environment. We present an analog RFI detector for microwave radiometers intended to mitigate the above risks.

The double detector (DD) for RFI detection includes a square-law diode detector with short integration time for measuring the total power out of the radiometer, followed by a second diode detector which acts as a higher-order statistical fourth-moment detector. See Figure 1 for block diagram of the system.

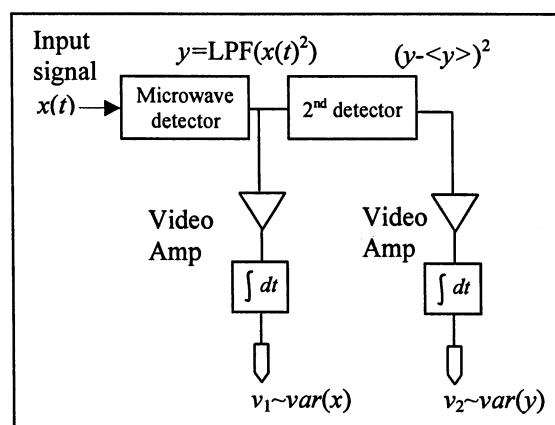

Figure 1: Block diagram of system

The signal power measured by the square-law detector (without interference) consists of naturally occurring thermal emission, including that from the sky, plus thermal noise generated in the radiometric system, all whose statistical properties follow Gaussian distributions. Gaussian signals have a constant relationship between their power, or the second central moment, μ_2 , and their fourth central moment, μ_4 . The ratio

$$\beta_2 = \frac{\mu_4}{\mu_2^2} \quad (1)$$

is called the kurtosis and is equal to three if the input is Gaussian. The deviation of this quotient from its constant value of three is an indicator of the presence of interferers such as communications or radar signals which are inherently non-Gaussian. Since the kurtosis is dependent on the statistical properties of the measured signals, low level RFI that would be undetected by methods such as pulse blanking would be easily identified.

The DD, however does not measure the actual fourth central moment of the signal, resulting in a pseudo kurtosis instead of the true kurtosis defined by (1). The square-law detector in Figure 1 measures the second central moment or power as do total power radiometers which has a low-pass output, y , and the measured result is v_1 in Figure 1. The second detector then measures the square of y minus its mean with the final output being v_2 , which is the ac power or variance of the low pass filtered output from the first detector. The second and pseudo fourth central moments of this system are therefore v_1 and v_2 , respectively assuming linearity and no dc offsets.

The moment ratio or pseudo kurtosis for the system shown in Figure 1 is therefore defined as

$$pk \equiv \frac{\text{var}(y)}{\langle y \rangle^2} = \frac{v_2}{v_1^2} \quad (2)$$

where $x(t)$, is any signal, y is the low pass filtered value of $x^2(t)$ and var is variance. By modeling the radiometer pre-detection signal as a bandpass random process and assuming linearity of the system, the pseudo kurtosis using (2) is equal to one if $x(t)$ is Gaussian. This pseudo kurtosis, (pk), will behave in a similar manner as the true kurtosis and act as the RFI indicator in this setup.

This novel design which uses purely analog components at radio and/or intermediate frequencies allows the system to easily augment conventional radiometer architectures used in both airborne and space borne instruments. An equivalent high-speed digital design would add an impractical level of cost and complexity to radiometer designs using today's technology.

We will present results from field and laboratory experiments and suggest options for applications to future radiometer systems.