

**The measurement of drape for nonwoven and conventional  
textile fabrics**

Reham Abdelbaset Elsayed Sanad

Submitted in accordance with the requirements for the degree of  
Doctor of philosophy

The University of Leeds  
School of Design

February, 2013

The candidate confirms that the work submitted is her own, except where work which has formed part of jointly-authored publications has been included. The contribution of the candidate and the other authors to this work has been explicitly indicated below. The candidate confirms that appropriate credit has been given within the thesis where reference has been made to the work of others. She has two jointly-authored publications:

SANAD, R., T. CASSIDY and V. CHEUNG. 2012. Fabric and Garment Drape Measurement - Part 1. *Journal of Fiber Bioengineering and Informatics*,**5**(4), pp.341-358.

SANAD, R., CASSIDY, T., CHEUNG, V. & EVANS, E. 2013. Fabric and Garment Drape Measurement - Part 2. *Journal of Fiber Bioengineering and Informatics*,**6**(1), pp.1- 22.

This copy has been supplied on the understanding that it is copyright material and that no quotation from the thesis may be published without proper acknowledgement.

## **Acknowledgements**

I am immensely grateful to my supervisors, Prof. Tom Cassidy, Dr. Vien Cheung and Mrs. Elaine Evans for their inspirational supervision, guidance, constructive criticism, support, their patience and unconditional assistance during this work which helped to shape this research.

I would like to thank Dr. Katherine Beverly for her supervision and support at the commence of my research.

I would like to offer my special thanks to the Egyptian government for funding this research project and supporting me during this study.

I would like to thank the fashion design department staff for their support during carrying out my garment making.

I also like to acknowledge my special thanks to Mr Michael Brooks for his support in the laboratory work.

I also thank to my friends and colleagues for all their help, inspiration and support during visual assessments.

Also, a very special thank you is extended to my colleagues and seniors in Faculty of applied arts, university of Damietta in Egypt for their support during my study.

## **Abstract**

The importance of the drape properties of fabrics on final garment appearance and fit has been long understood and a great deal of research has been carried out in this area. More recently, nonwoven fabrics have begun to create interest among the apparel and fashion design community. In this study, the conventional method of measuring fabric drape was compared with garment drape measurement using an alternative drape measurement system based on an image analysis technique. Garment drape was investigated using dresses suspended on a mannequin. A garment chosen was a shift dress because of its relatively uncomplicated style and shape. Hydroentangled nonwovens were selected as they show good performance and similarity to conventional fabrics in terms of physical and mechanical properties. A graphical user interface was developed to carry out the image analysis and to calculate drape values identifying and determining 23 drape parameters. A range of fabrics including conventional (knitted, woven) and nonwoven fabrics were compared in terms of FAST properties, drape coefficient and drape values. Some nonwoven fabrics were found to give similar performance to some conventional fabrics and better than others. Subjective assessment of the fabric range was carried out in terms of drape amount and preference. Low agreement was found between individuals with regard to preferred drape amount and high agreement with respect to actual drape amount. Nonwovens were found to be better preferred over some conventional fabrics. Most of the drape values of fabric and garment were found to have poor correlations.

## Table of Contents

<b>Acknowledgements.....</b>	<b>ii</b>
<b>Abstract.....</b>	<b>iii</b>
<b>Table of Contents .....</b>	<b>iv</b>
<b>List of Figures .....</b>	<b>xiv</b>
<b>List of Tables .....</b>	<b>xix</b>
<b>Chapter 1 Introduction.....</b>	<b>1</b>
1.1 Background.....	1
1.2 Problem.....	2
1.3 Aim 3	
1.4 Objectives .....	3
<b>Chapter 2 Fabric objective measurement (FOM).....</b>	<b>5</b>
2.1. Introduction .....	5
2.2. Physical properties.....	6
2.2.1. Fabric construction.....	6
2.2.2. Weight.....	8
2.2.3. Cover factor .....	8
2.3. Mechanical properties .....	8
2.3.1. Compression.....	8
2.3.1.1. Thickness.....	8
2.3.1.2. Hardness.....	9
2.3.1.3. Compression modulus .....	9
2.3.1.4. Density.....	9
2.3.2. Tensile .....	10
2.3.3. Shear .....	10
2.3.4. Rigidity .....	11
2.3.4.1. Measurement of deformation .....	11
2.3.4.1.1. The cantilever test.....	11
2.3.4.1.1.1. Shirley stiffness tester.....	13
2.3.4.1.1.2. FAST 2 (bending meter) .....	14
2.3.4.1.1.3. Russell test .....	14
2.3.4.1.2. Hanging loop tests .....	14
2.3.4.1.1. Bending loop test .....	16

2.3.4.1.2.	Cassidy <i>et al.</i> Bending box.....	17
2.3.4.1.3.	Cassidy Instron test for bending.....	17
2.3.4.1.4.	Planoflex .....	17
2.3.4.1.5.	Ordinary beam test.....	17
2.3.4.1.6.	Hanging strip .....	17
2.3.4.2.	Measurement of deforming force .....	18
2.3.4.2.1.	Gurley stiffness tester .....	18
2.3.4.2.2.	Schiefer Flexometer .....	19
2.3.4.2.3.	Munzinger Impact test.....	19
2.3.4.2.4.	Searle pendulum test .....	19
2.3.4.2.5.	Twisting rigidity.....	20
2.3.4.3.	Relation between methods of measuring fabric stiffness .....	20
2.3.5.	Bending modulus .....	23
2.3.6.	Friction .....	24
2.3.7.	Buckling .....	24
2.4.	FOM systems .....	25
2.4.1.	Kawabata evaluation system of fabrics (KES-F) .....	25
2.4.1.1.	Shear test (KES-FB-1) .....	26
2.4.1.2.	Tensile test (KES-FB-1) .....	27
2.4.1.3.	Bending test (KES-FB2).....	29
2.4.1.4.	Compression test (KES-FB-3).....	30
2.4.1.5.	Surface Friction and Roughness tests (KES- FB-4).....	31
2.4.2.	The Fabric assurance by simple testing (FAST) .....	34
2.4.2.1.	FAST 1: Compression meter.....	34
2.4.2.2.	FAST 2: Bending meter .....	34
2.4.2.3.	FAST 3: Extension meter .....	35
2.4.2.4.	FAST 4: Dimensional stability test .....	35
2.5.	Subjective evaluation .....	35
2.5.1.	Training of assessors .....	36
2.5.2.	Number of assessors .....	36
2.5.3.	Assessment procedure .....	36
2.5.4.	Assessment scale and rating technique.....	36
2.6.	Summary.....	37

<b>Chapter 3 Drape measurement .....</b>	<b>38</b>
3.1 Introduction .....	38
3.2 Drapemeters .....	39
3.2.1 Static drape testers .....	40
3.2.2 Integrated drapemeters .....	45
3.2.2.1 Image analysis technique.....	45
3.2.2.2 Photovoltaic drapemeters .....	46
3.2.2.3 Dynamic drapemeter.....	47
3.2.2.4 Alternative drapemeters .....	51
3.3 Drape parameters .....	55
3.3.1 Drape coefficients (DC) .....	55
3.3.2 Static drape profile/image analysis.....	56
3.3.3 Fourier analysis.....	61
3.3.4 Standard drape values .....	62
3.3.5 Measurement of number of nodes objectively.....	62
3.3.6 Dynamic drape parameters .....	63
3.3.7 Garment drape parameters .....	65
3.4 Summary.....	65
<b>Chapter 4 Factors affecting fabric drape .....</b>	<b>69</b>
4.1 Fabric composition and structures .....	69
4.2 Fabric mechanical properties .....	72
4.3 Fabric finishing .....	76
4.4 Effect of test procedure on stability of drape values.....	78
4.5 Supporting disc size .....	79
4.6 Controlling drape behaviour of fabric .....	79
4.7 Time80 .....	
4.8 Garment Drape .....	82
4.8.1 Fabric drape versus garment drape .....	82
4.8.2 Grain alignment.....	83
4.8.3 Interfacings.....	83
4.8.4 Seams.....	85
4.8.4.1 Seam existence .....	85
4.8.4.2 Seam allowance (SA) .....	86
4.8.4.3 Seam position .....	87
4.8.4.4 Seam direction .....	87

4.8.4.5	Seam number (SN) .....	88
4.8.4.6	Seam type.....	89
4.8.4.7	Girth ease allowance .....	90
4.8.5	Deformed garment drape .....	90
4.8.5.1	Fabric skew and drape.....	90
4.8.5.2	Asymmetrical body features(Wearer body).....	91
4.8.5.3	Pattern layout and production markers .....	91
4.8.5.4	Sewing operations .....	91
4.8.5.5	Unbalanced seams .....	91
4.9	Subjective assessment of drape .....	91
4.10	Prediction of drape coefficient.....	95
4.11	Drape simulation .....	100
4.12	Summary.....	102
	<b>Chapter 5 Nonwoven fabrics.....</b>	<b>106</b>
5.1	Introduction .....	106
5.2	Manufacturing processes .....	106
5.2.1	Web formation.....	106
5.2.1.1	Dry laying .....	107
5.2.1.2	Wet laying .....	108
5.2.1.3	Polymer laying .....	108
5.2.2	Web bonding.....	110
5.2.2.1	Chemical (adhesion) bonding .....	110
5.2.2.2	Thermal (cohesion) bonding .....	110
5.2.2.3	Mechanical (friction) bonding .....	111
5.2.2.3.1	Hydroentangled nonwovens.....	111
5.2.2.3.2	Principle and entanglement mechanism .....	112
5.2.2.3.3	Factors affecting fabric produced.....	112
5.2.3	Fibre selection.....	113
5.2.4	Finishing treatments.....	114
5.3	Nonwovens characteristics.....	115
5.3.1	Nonwovens versus woven .....	115
5.3.2	Nonwovens for apparel manufacture .....	116
5.3.3	Mechanical properties including drape.....	117
5.4	Nonwovens and apparel industry .....	121
5.4.1	Nonwoven interlining.....	122



5.4.2	Outer wear .....	122
5.5	Nonwovens and fashion .....	125
5.6	Commercial nonwovens for apparel products .....	126
5.6.1	Evolon fabrics .....	127
5.6.2	Miratec fabrics .....	127
5.6.3	Tencel® .....	128
5.6.4	Ultrasuede® .....	128
5.6.5	Neotis™ (Formerly known as DuPont Inova™) .....	129
5.6.6	Tyvek® .....	129
5.7	Summary .....	129
	<b>Chapter 6 Fabric range identification .....</b>	<b>131</b>
6.1	Introduction .....	131
6.1.1	Fabrics types .....	132
6.1.2	Physical properties .....	132
6.1.2.1	Woven fabrics group .....	132
6.1.2.2	Knitted fabrics group .....	132
6.1.2.3	Nonwoven fabrics group .....	132
6.2	Experimental (Measurement of the low stress mechanical properties) .....	133
6.2.1	Measurement of the thickness .....	134
6.2.2	Measurement of the bending length .....	135
6.2.2.1	Initial test using FAST 2 .....	135
6.2.2.2	Selection of alternative methods .....	135
6.2.2.3	Sample preparation and size .....	136
6.2.2.3.1	Shirley stiffness tester .....	136
6.2.2.3.2	Heart loop and bending loop tests .....	136
6.2.2.3.3	FAST 2 bending meter .....	137
6.3	Procedure .....	138
6.3.1	Shirley stiffness tester .....	138
6.3.2	FAST 2 bending meter .....	138
6.3.3	Heart loop test .....	138
6.3.4	Bending loop test .....	139
6.4	Comparative studies of bending length measurement methods .....	140
6.4.1	Aspects of comparison .....	140
6.4.1.1	Correlation strength .....	140

6.4.1.2	Quantitative relation/prediction.....	140
6.4.1.3	Agreement between methods .....	140
6.4.1.4	Precision (reproducibility).....	141
6.4.1.5	Sensitivity analysis .....	142
6.4.1.6	Discrimination ability (sensitivity index).....	143
6.4.1.7	Variance dependence on fabric stiffness .....	143
6.4.1.8	Ease of operation and speed of obtaining results .....	143
6.5	Two groups of methods for comparison .....	143
6.6	Results and Discussion .....	144
6.6.1	Comparative study of the four methods (Shirley - FAST 2 - Heart loop – Bending loop) .....	144
6.6.1.1	Correlation strength .....	146
6.6.1.2	Quantitative relation between methods.....	146
6.6.1.3	Agreement between measurement methods .....	146
6.6.1.4	Relative precision <b>CV<sub>f</sub></b> .....	146
6.6.1.5	Relative sensitivity <b>CV<sub>m</sub></b> .....	147
6.6.1.6	Discrimination ability .....	148
6.6.1.7	Effect of fabric's stiffness on difference between methods.....	148
6.6.1.8	Ease of operation.....	149
6.6.1.9	Summary.....	150
6.7	Comparison between the Heart loop and Bending loop tests ...	150
6.7.1	Correlation strength and quantitative relation.....	152
6.7.2	Agreement between Heart loop and Bending loop methods .....	152
6.7.3	Relative precision <b>CV<sub>f</sub></b> .....	152
6.7.4	Relative sensitivity <b>CV<sub>m</sub></b> .....	153
6.7.5	Discrimination ability .....	154
6.7.6	Variation of <b>BL</b> among methods according to fabric stiffness.....	154
6.7.7	Summary.....	155
6.8	Measurement of the extensibility.....	156
6.9	Results and discussion .....	156
6.9.1	Thickness.....	156
6.9.2	Extensibility .....	158
6.9.3	Shear rigidity( <b>G</b> ) .....	161

6.9.4	Bending length .....	162
6.9.5	Bending rigidity ( <b>BR</b> ) .....	163
6.9.6	Bending modulus .....	164
6.9.7	Formability( <b>FR</b> ) .....	165
6.10	Summary .....	166
	<b>Chapter 7 Fabric drape measurement.....</b>	<b>167</b>
7.1	Introduction .....	167
7.2	Experimental .....	167
7.2.1	Apparatus.....	167
7.2.2	Samples .....	168
7.2.3	Test procedure .....	168
7.2.3.1	General .....	168
7.2.3.2	Manual (cut and weigh) method.....	169
7.2.3.3	Digital method .....	169
7.2.3.4	Calculation of drape coefficient.....	171
7.3	Results and discussion .....	171
7.3.1	Drape measurement of the whole fabrics range (D30).....	171
7.3.1.1	Drape coefficient ( <b>DC30</b> ) .....	171
7.3.1.2	Correlation between manual and digital methods .....	173
7.3.1.3	Nodes/Folds (N30).....	173
7.3.1.3.1	Number of nodes (NN30) .....	175
7.3.1.3.2	Correlation between number of nodes and drape coefficient	177
7.3.1.3.3	Nodes' severity/size (NS30).....	177
7.3.1.3.4	Nodes' orientation (NO30) .....	177
7.3.2	Drapeability of nonwoven fabrics (D36) .....	178
7.3.2.1	Drape coefficient ( <b>DC36</b> ) .....	178
7.3.2.2	Nodes .....	179
7.3.2.2.1	Number of nodes (NN) .....	179
7.3.2.2.2	Node severity/size (NS) .....	180
7.3.2.2.3	Drape profile/ Node orientation .....	182
7.3.3	Control chart of fabric's drapeability using their mechanical properties .....	182
7.4	Summary.....	189

<b>Chapter 8 Assessment of garment drapeability using an image analysis technique.....</b>	<b>190</b>
8.1 Introduction .....	190
8.2 Experimental .....	190
8.2.1 Samples / Images .....	190
8.2.1.1 Garment samples (pattern cut and dress making) .....	190
8.2.1.2 Garment images (Picture capture and preparation).....	193
8.2.1.3 Fabric samples/images .....	195
8.2.2 Image analysis procedure .....	196
8.2.3 Apparatus/Tools .....	200
8.3 Results and discussion .....	203
8.3.1 Correlation between fabric and garment drape values.....	203
8.3.2 Correlation between drape coefficient and drape values measured for fabrics on drapemeter .....	204
8.4 Summary.....	205
<b>Chapter 9 Subjective assessment of fabric and garment drape .....</b>	<b>206</b>
9.1 Introduction .....	206
9.2 Experimental .....	207
9.2.1 Assessment/Ranking method.....	207
9.2.2 Samples .....	207
9.2.3 Presentation of samples.....	207
9.2.3.1 Fabrics and garments (real samples).....	208
9.2.3.2 Images assessment .....	209
9.2.4 Data analysis.....	209
9.3 Results and discussion .....	212
9.3.1 Agreement between judges (producing rank average).....	213
9.3.2 Correlation between methods .....	214
9.3.3 Drape ability ranking .....	215
9.3.4 Drape preference ranking .....	217
9.3.5 Correlations between subjective assessment of drapeability and drape coefficient.....	220
9.4 Summary.....	220
<b>Chapter 10 Prediction of fabric and garment drapeability.....</b>	<b>221</b>
10.1 Introduction .....	221

10.2 Regression analysis .....	222
10.2.1 Model selection methods .....	224
10.2.2 Regression analysis performed.....	225
10.3 Results and discussion .....	226
10.3.1 Prediction of drape rank scores using the drape values.....	226
10.3.2 Prediction of fabric and garment drapeability using the mechanical properties .....	232
10.3.3 Prediction of the drape values using the mechanical properties .....	236
10.4 Summary.....	238
<b>Chapter 11 Conclusions and future work .....</b>	<b>239</b>
11.1 Conclusions.....	239
11.2 Limitations of the current research .....	242
11.3 Future work .....	242
<b>List of References .....</b>	<b>244</b>
<b>List of Abbreviations.....</b>	<b>258</b>
<b>Appendix A Measurement of the mechanical properties.....</b>	<b>260</b>
A.1 Measurement of the thickness (mm).....	260
A.2 Measurement of the extensibility .....	260
A.3 Shear rigidity results (N/m) .....	261
A.3 Measurement of the bending length (cm) .....	261
A.4 Measurement of the bending rigidity ( $\mu\text{Nm}$ ).....	261
A.5 Measurement of the bending modulus ( $\text{Kg/cm}^2$ ) .....	262
A.6 Measurement of the formability ( $\text{mm}^2$ ).....	263
<b>Appendix B Measurement of the drape coefficient.....</b>	<b>264</b>
B.1 Measurement of the drape coefficient 30.....	264
B.2 Measurement of the drape coefficient 36.....	264
<b>Appendix C Measurement of the drape values.....</b>	<b>265</b>
C.1 Fabric drape values measurement .....	265
C.2 Garment drape values measurement .....	266
<b>Appendix D Subjective assessment of fabric and garment drape.....</b>	<b>267</b>
D.1 Physical fabric drapeability .....	267
D.2 Physical garment drapeability .....	268
D.3 Assessment of fabric drapeability using images .....	269
D.4 Assessment of garment drapeability using images.....	270

D.5 Assessment of garment drape preference.....	271
<b>Appendix E Prediction of fabric and garment drapeability .....</b>	<b>272</b>
E.1 Regression analysis of garments images' rank scores on the drape values measured for the respective images.....	272
E.2 Regression analysis of fabrics images' rank scores on the drape values measured for the respective images.....	272
E.3 Regression analysis of garments images' rank scores on the mechanical properties measured for the respective images .....	273
E.4 Regression analysis of fabrics images' rank scores on the mechanical properties measured for the respective images .....	273

## List of Figures

Figure 2.1 Flexometer (reproduced from (Peirce 1930)) .....	12
Figure 2.2 Schematic representation of the measurement of the bending length based on the cantilever principle(reproduced from (CSIRO 1991)) .....	13
Figure 2.3 Shirley stiffness tester (reproduced from (British standard Institution 1990) ) .....	13
Figure 2.4 FAST 2 - bending meter (reproduced from (CSIRO 1991)).....	14
Figure 2.5 Russell test for measuring fabric bending length (reproduced from (Russell 1994)).....	14
Figure 2.6 Examples of loop test form (a) Ring loop, (b)Heart loop(reproduced from (Peirce 1930)) .....	15
Figure 2.7 Bending loop (a) A loop of neoprene, (b) loop shape as plotted by a computer (reproduced from (Stuart 1966)) .....	16
Figure 2.8 Gurley stiffness tester(reproduced from (Winn and Schwarz 1940b)).....	18
Figure 2.9 Schiefer Flexometer(reproduced from (Schiefer 1933)).....	19
Figure 2.10 Shear test using KES-FB-1 (Pandurangan 2003).....	27
Figure 2.11 An example of Shear force-angle resulting curve, where $F_s$ is the shearing force and $\theta$ is the measured angle (reproduced from(Gider 2004)).....	27
Figure 2.12 Tensile test using KES-FB-1 (Pandurangan 2003) .....	28
Figure 2.13 A Typical Force-Extension Tensile Curve of a Fabric (KES-F1) (reproduced from (Saville 1999)) .....	28
Figure 2.14 Pure bending test (Pandurangan 2003).....	29
Figure 2.15 Bending moment-curvature plot from pure bending test (Saville 1999).....	30
Figure 2.16 Compression test (Gider 2004) .....	31
Figure 2.17 Pressure-Thickness curve resultant from compression test (Gider 2004).....	31
Figure 2.18 Surface roughness measurement (reproduced from (Saville 1999)) .....	32
Figure 2.19 Surface friction measurement (reproduced from (Saville 1999)) .....	32
Figure 2.20 Surface thickness variation (reproduced from (Saville 1999)).....	32
Figure 2.21 Surface friction variation (Saville 1999).....	32

Figure 3.1 Schematic diagram of F.R.L. optical drapemeter (Chu, Cummings and Teixeira 1950).....	40
Figure 3.2 Drape diagram (the dark grey area is the shadow of the draped sample on the annular ring) ((reproduced from(Chu, Cummings and Teixeira 1950)) .....	41
Figure 3.3 Improved F.R.L. drapemeter (reproduced from (Chu, Cummings and Teixeira 1950)) .....	42
Figure 3.4 An F.R.L drapemeter improved by Cusick in 1962, (a) Schematic diagram(b) Photograph(reproduced from (Cusick 1965; 1962)) .....	43
Figure 3.5 Drapemeter used in British Standards with codes: BS 5058:1973, BS EN ISO 9073-9:1998 and BS : ISO9073-9:2008.....	44
Figure 3.6 Tools used in studying fabric's drape by image processing technology proposed by BS EN ISO 9073-9:2008 .....	46
Figure 3.7 Contour of a specimen on a vertically draped fabric (Ranganathan et al. 1986).....	48
Figure 3.8 (a) sample dimensions, (b) Needle suspended on the specimen, (c)The sample mounted on the apparatus(reproduced from(Ranganathan et al. 1986)).....	48
Figure 3.9 (a) Dynamic drape tester, (b) System of measuring dynamic drape using an image analysis method (reproduced from (Matsudaira and Yang 2000)).....	50
Figure.3.10 Sylvie 3D Drape tester (reproduced from (Al-Gaadi, Göktepe and Halász 2011)).....	51
Figure 3.11 (a) Schematic diagram and (b) photo of Hearle and Amirbayat 1988 multipurpose tester of drapeability (reproduced from (Hearle and Amirbayat 1988)).....	52
Figure 3.12 Drape elevator of Mizutani et al. (Mizutani, Amano and Sakaguchi 2005).....	53
Figure 3.13 Pan's system for measuring fabric hand (Pan 2007).....	54
Figure.3.14 Stages of extraction tests used by (reproduced from (Grover et al. 1993)).....	54
Figure 3.15 Jevšnik and Geršak drape parameters (Jevšnik and Geršak 2004).....	59
Figure 6.1 Definition of the Bending loop height.....	139
Figure 6.2 Average coefficient of variation of the measured fabrics for the four methods (Shirley, FAST 2, Heart loop and Bending loop).....	147
Figure 6.3 Relative spread among average CVf for the four methods (Shirley, FAST 2, Heart loop and Bending loop).....	147
Figure 6.4 Discrimination ability of the four methods (Shirley, FAST 2, Heart loop and Bending loop).....	148



Figure 6.5 Average <i>BL</i> value of each fabric measured using the four methods (Shirley, FAST 2, Heart loop and Bending loop) and their error over the methods.....	149
Figure 6.6 Heart loop and Bending loop methods' precision.....	153
Figure 6.7 Relative spread among average $CV_m$ (Relative sensitivity) .....	153
Figure 6.8 Discrimination ability of Heart loop and Bending loop tests.....	154
Figure 6.9 Error in measuring fabrics <i>BL</i> stiffness between methods (Heart loop and Bending loop).....	155
Figure 6.10 $T_2$ and $T_{100}$ of the tested fabrics .....	157
Figure 6.11 Surface thickness.....	158
Figure 6.12 The measured extensibility .....	159
Figure 6.13 Measured extensibility at 5 gf/cm .....	160
Figure 6.14 Measured extensibility at 20 gf/cm .....	161
Figure 6.15 Measured extensibility at 100 gf/cm .....	161
Figure 6.16 Shear rigidity .....	162
Figure 6.17 Measured bending length.....	163
Figure 6.18 The bending rigidity of the tested fabrics .....	164
Figure 6.19 The bending modulus of the tested fabrics .....	165
Figure 6.20 The formability of the tested fabrics.....	166
Figure 7.1 Cusick's drapemeter and tripod used in fabric drape measurement.....	168
Figure 7.2 Original image for a tested sample.....	169
Figure 7.3 A calibrated image for a draped sample.....	170
Figure 7.4 The inverse of the paper ring is filled with one colour.....	170
Figure 7.5 A thresholded shadow.....	170
Figure 7.6 Final image.....	171
Figure 7.7 The drape coefficient measured using 30cm diameter by the digital method.....	173
Figure 7.8 The number of nodes of the tested fabrics in the D30 test.....	176
Figure 7.9 The drape coefficient DC30 and DC36 of nonwoven fabrics .....	179
Figure 7.10 Number of nodes from D36 .....	179
Figure 7.11 Number of nodes from D30 and D36.....	180

Figure 7.12 Measured drape coefficient and mechanical properties of knitted fabrics .....	185
Figure 7.13 Measured drape coefficient and mechanical properties of woven fabrics.....	186
Figure 7.14 Measured drape coefficient and mechanical properties of nonwoven fabrics .....	187
Figure 7.15 Correlations between conventional fabrics and nonwovens' measured properties (the shaded areas are for the conventional fabrics).....	188
Figure 8.1 The A line shift dress pattern used to cut the dresses .....	191
Figure 8.2 Stitch types used in making the dresses .....	192
Figure 8.3 Different views for the mannequin employed .....	194
Figure 8.4 Original image captured for a dress on the suspended mannequin.....	194
Figure 8.5 Dresses' images used for image analysis.....	195
Figure 8.6 Fabricimages used for image analysis.....	196
Figure 8.7 Measurement of wave characteristics/dimensions (length, amplitude and height).....	199
Figure 8.8 "Drape" Graphical user interface (example of image processed).....	202
Figure 9.1 Summary of subjective tests conducted.....	208
Figure 9.2 Dresses tested in the subjective assessment (real garments).....	210
Figure 9.3 Kendall's coefficients of concordance for methods of drape assessment.....	213
Figure 9.4 Average ranks of garments images' drape level .....	215
Figure 9.5 Average ranks of garment drape preference .....	218
Figure 10.1 Prediction of fabric and garment drape.....	222
Figure 10.2 Correlation coefficients (r) of image results and the corresponding rank scores.....	227
Figure 10.3 Correlation coefficients (r) of image results and the corresponding rank scores.....	227
Figure 10.4 Correlation coefficients (r) of image results and the corresponding rank scores.....	228
Figure 10.5 Correlation coefficients (r) of image results and the corresponding rank scores.....	229
Figure 10.6 Correlation coefficients (r) of image results and the corresponding rank scores.....	229

<b>Figure 10.7 The best drape values predictors of each group of fabric form and type drape rank scores.....</b>	<b>231</b>
<b>Figure 10.8 Correlation coefficients between rank scores and the mechanical properties for all group of samples.....</b>	<b>232</b>
<b>Figure 10.9 Correlation coefficients between rank scores and the mechanical properties for conventional samples.....</b>	<b>233</b>
<b>Figure 10.10 Correlation coefficients between rank scores and mechanical properties for nonwoven samples. ....</b>	<b>233</b>
<b>Figure 10.11 The mechanical properties best predictors of each group (fabric and garment) and type drape rank scores.....</b>	<b>236</b>

## List of Tables

Table 2.1 Summary of properties measured using KES-F.....	33
Table 3.1 Drape researchers contribution to development of drapemeters and parameters.....	67
Table 4.1 Levels to control the development of drapeable fabrics (Tandon and Matsudaira, 2010).....	80
Table 6.1 Woven fabrics' physical properties.....	133
Table 6.2 Knitted fabrics' physical properties .....	133
Table 6.3 Nonwoven fabrics' physical properties .....	133
Table 6.4 The measured and calculated low stress mechanical properties using the FAST system .....	134
Table 6.5 <i>BL</i> (cm) measured using: Shirley - FAST 2 - Heart loop and Bending loop tests and other statistical values.....	145
Table 6.6 Coefficient of determination ( $R^2$ ) Shirley-FAST 2- Heart loop and Bending loop tests.....	146
Table 6.7 The best line fit equations from the correlation between the pairs of bending length measurement methods .....	146
Table 6.8 Heart loop and Bending loop tests <i>BL</i> (cm), standard deviation, coefficient of variation and other statistical values ...	151
Table 6.9 The best line fit of the correlation between the Heart loop and Bending loop tests before and after adding the five fabrics .....	152
Table 7.1 Randomly selected images for the face and back of the tested fabrics in D30 .....	174
Table 7.2 Randomly selected images for the face and back of the tested fabrics in D36 .....	181
Table 7.3 Summary of nonwoven fabrics' properties lying in the conventional fabrics range.....	184
Table 8.1 Seam types used in dress making .....	192
Table 8.2 Seam and stitch types' locations in Knitted K, Woven W and Nonwoven N fabrics .....	193
Table 8.3 Correlation coefficients and coefficients of determination between parameters measured for fabrics and dresses tested.....	203
Table 8.4 Significant correlations between Drape coefficient and Drape values.....	204
Table 9.1 Kendall's <i>W</i> test statistic for methods of drape assessment .....	213

<b>Table 9.2 Correlation coefficient between drape assessment tests ...</b>	<b>214</b>
<b>Table 9.3 Calculation of Bonferroni's least significant range difference for the garment images' drapeability .....</b>	<b>216</b>
<b>Table 9.4 Multiple paired comparison using Bonferroni's LSD (Garment images' drape ability).....</b>	<b>216</b>
<b>Table 9.5 Calculation of Bonferroni's least significant range difference for the garment drape preference.....</b>	<b>218</b>
<b>Table 9.6 Multiple paired comparison using Bonferroni's LSD (Real garment drape preference).....</b>	<b>219</b>
<b>Table 10.1 Regression analysis of garments' images rank scores on the drape values measured for the respective images .....</b>	<b>230</b>
<b>Table 10.2 Regression analysis of fabrics' images rank scores on the drape values measured for the respective images.....</b>	<b>230</b>
<b>Table 10.3 Correlations between mechanical properties.....</b>	<b>234</b>
<b>Table 10.4 Regression analysis of garments' images rank scores on the mechanical properties measured for the respective images.....</b>	<b>235</b>
<b>Table 10.5 Regression analysis of fabrics' images rank scores on the mechanical properties measured for the respective images.....</b>	<b>235</b>
<b>Table 10.6 Multiple regression equations of fabrics and garments drape values (Basic characteristics) prediction using the mechanical properties .....</b>	<b>237</b>
<b>Table 10.7 Independent variables of the mechanical properties for predicting fabrics and garments drape values (Wave measurements).....</b>	<b>237</b>
<b>Table 10.8 Independent variables of the mechanical properties for predicting fabrics and garments drape values (wave analysis and Fourier).....</b>	<b>238</b>

## **Chapter 1 Introduction**

### **1.1 Background**

The apparel industry is a term used for industries concerned with all the processes related to garment design and manufacture in addition to the distribution and use of them. It is one of the most globalised industries in the world. A great growth of all production processes (including manufacturing, designing and retailing) and a remarkable rise in global trade has been witnessed in countries all over the world (Bonacich *et al.* 1994).

Due to the market competition, makers (designers and manufacturers) and sellers of fashionable clothing are keen to move in innovative directions with new technologies and materials. Therefore, among their challenges is to develop fashion apparel utilising non-conventional fabrics.

Within the past few years, the textile industry has seen a renewed interest in the use of nonwoven fabrics as a non-conventional fabric taking into consideration their various advantages. They have a fast production rate, a high response to the frequent changes in the fashion industry, low price, easy production that greatly exceeds that attainable by knitting and weaving machines which could encourage its existence in the apparel market (Termonia 2003). The use of nonwoven fabrics as a non-conventional fabric in the apparel industry is considered one of the innovation-adoption methods for introducing fashion solutions. Subsequently, fashionable garments could be developed using nonwoven fabrics. Moreover, the movement of nonwovens into the fashion apparel market will require new research including tests and assessments (Orzada 2006).

Nonwoven fabric appearance is essential for characterising and determining the acceptability for apparel. Drape, pilling, texture and wrinkle are recognised as major appearance attributes of an apparel fabric. Conventionally, these attributes are used to estimate and judge garment appearance by sensibly evaluating the individual parameter with an expert opinion. Expressions such as stiff or limp, hard or soft, and rough or smooth are used. This method has a good correlation with some of the existing objective methods for analysing fabric appearance (Behera and Mishra 2006). It is desirable to devise physical tests that analyse, reflect the felt sensations, and allocate numerical values to the measurements (Peirce 1930). In recent years, there has been a great deal of interest in investigating the mechanical property behaviour of fabrics due to developments in objective evaluation techniques.

Drape is one of the properties, which affects the appearance of fabrics. It is a unique property that allows a fabric to bend in more than one direction with double curvature. The importance of drape for garments makes it a consideration of researchers to extend the work on its measurement. For many years, textile researchers studied this attribute in order to evaluate the drape quality and improve the drape appearance of garments. However, fabric drape instruments and measurements can be developed to be more realistic and dependable. Studying the drape behaviour of apparel could enhance the prediction of fabric products' design and their applications.

It is important for researchers in the apparel field to work with nonwoven fabric firms to encourage development to meet the fashion needs of aesthetics and function.

This study is conducted to focus on the potential of nonwovens apparel appearance according to their mechanical properties (specially drape) in order to begin the taking up and acceptance process for nonwovens in the apparel industry. Drape behaviour of nonwovens is an important field of research, especially in the development of the apparel industry. Since, fashion apparel is a wide open market for nonwoven fabrics. All this may enhance the opportunities for nonwovens to be taken up by the apparel industry(Orzada 2006).

This study is conducted to identify and determine an alternative method/system which would produce more dependable parameters than the already existing conventional ones and could consequently give a better understanding of nonwoven materials for apparel. This system used a dress on a mannequin, instead of a fabric on circular disc (traditional method), which would be more akin to the real apparel drape. A comparison between traditional and the new alternative methods was conducted.

At present, research in this area is very limited. This study presents a fundamental drape analysis of nonwoven fabrics using different methods. Investigating nonwovens' drape can improve apparel design and fabric end-use applications. Moreover, it may contribute to garment drape prediction for clothing CAD systems(Hu and Chung 1998). This study may help workers in the apparel industry field to know more about the prediction of nonwoven garment appearance and drape behaviour.

## **1.2 Problem**

The fashion apparel industry until now has not exploited nonwoven fabrics and their advantages. The suitability of nonwovens to the end use (clothes specially) and their potentialities are suspected and uncertain for both manufacturers and consumers in the apparel industry and market.

Therefore, the appearance potentialities and their prediction should be studied to provide confidence in using nonwovens in making garments.

### **1.3 Aim**

The aim is to produce an alternative method for measuring the drapeability of fabrics which might offer a more suitable tool for the assessment of new nonwoven fabrics aimed at shell fabrics for the apparel market.

### **1.4 Objectives**

The objectives are listed below:

- To carry out an exhaustive literature review on previous research about fabric objective measurement with particular reference to drapeability.
- To choose a range of conventional and nonwoven fabrics and to subject these to conventional (extant) measurement systems and to analyse the results.
- To produce a suitable garment from these fabrics in order to allow the assessment of garment drape.
- To develop a tool which will allow the capture of suitable drape images from the garments for image analysis and comparison with subjective assessments and conventional fabric measurements.
- To produce a GUI (graphical user interface) to allow fast and easy calculations of drape parameters.
- To determine the efficacy of the new alternative method and tools for drape measurement.
- To investigate factors affecting fabrics and garment drape including fabric physical and mechanical properties, including the theoretical prediction of fabrics and garment drape.

The experimental work was based on the assessment of available drape measurement methods for nonwovens. An investigation and study of nonwoven drape aspects was carried out. This experimental work was conducted in order to develop a better methodology to predict the drape of nonwovens for apparel. The differences in drape behaviour between hydroentangled nonwoven fabrics and conventional knitted and woven constructions is described. A comparative study for drape behaviour was conducted in terms of FAST properties, drape coefficient and drape values proposed.

In these experimental studies, different testers and methods were used: FAST 2 (bending meter), Shirley stiffness tester, heart loop test and bending loop test will be used to evaluate the drape in terms of bending length. Comparative studies between these four methods were carried out. A



Cusick drapemeter is used to measure the drape coefficient and number of nodes and the suspension method was applied to investigate the drape appearance on a hung mannequin.

An alternative method of measuring fabric stiffness was investigated and correlated with fabric drape. This method's correlation with traditional methods of measuring fabric stiffness mentioned above was carried out.

Nonwoven fabrics which are the main focus of the study were compared with the conventional (woven – knitted) fabrics in terms of the above mentioned parameters. Since, the hydroentangled nonwoven fabrics have exhibited suitability for shirting fabrics(Saleh 2003) and apparel fabrics are the scope of study, therefore it was decided to source nonwoven fabrics. In order to obviate the effects of the weave structure on the measurement test results and the comparison of conventional fabrics with nonwovens, the most simple and appropriate woven and knitted fabrics have been selected. In applying the suspension method, a shift dress has been selected because of its simple construction in that it is sleeveless and hangs loosely from the shoulders with little definition in the waist area. (Fashion and Style 2012). A graphical user interface was developed to carry out image analysis for draped fabrics and garments.

## **Chapter 2**

### **Fabric objective measurement (FOM)**

#### **2.1. Introduction**

FOM is defined as “The evaluation of fabric handle, quality, and related fabric-performance attributes, in terms of objectively measurable properties”. It aims to evaluate and control fabric properties which contribute to its appearance quantitatively. FOM systems are a set of instruments used to measure a combination of fabric surface and mechanical properties in the aim of FOM (Bishop 1996).

FOM quality and efficiency is dominated by setting up reliable methods to express numerically subjective assessment. Equations can be applied to estimate those values and to determine suitable instruments and their accuracy.

Introducing a globalised FOM system is a desire for manufacturers and customers. There are different reasons for that need including the growing number of fabric types and finishes, the tendency to follow mechanisation in different procedures and applications, the lack and inaccuracy of fabric professionals for subjective assessment, the required quick response of fabric and garment production to the market and the need to develop an international language to describe and identify fabric characteristics.

FOM systems are essential for the reproduction of already existing or pre-identified fabrics and/or selecting the most suitable which is becoming more difficult in the presence of the variety of fabrics. Mainly, FOM is applied to identify and evaluate, numerically, fabric properties to be controlled in the production process, selection and suitability for end use. It is the best approach to choose and reproduce fabrics. Therefore, these are essential instrumental measurements to specify and control the features of, tailorability, and final performance of apparel fabric.

Based on this, fabric objective measurement is used to: help engineer fabric properties for desirable performance and quality, develop new finishes and finishing machinery and control the produced fabric to meet specific mechanical properties (from raw material to garment).

A globalised and reliable objective system of measurement should fulfil some financial and technical specifications. Its purchase price, setting, and maintenance expenses should meet the budget of as many manufacturers as possible. It should be safe and reliable electrically and mechanically, easy

to run and use. The most important criterion for an FOM is its accuracy and reproducibility (Bishop 1996; Saleh 2003).

Apparel appearance including handle, drape, lustre, smoothness, roughness and stiffness have been measured subjectively using a panel of judges. However, research studies claimed that these characteristics are related to fabric physical, mechanical and surface properties. These properties are able to be measured objectively using instruments (Bishop 1996)..

Different instruments are available for measuring these properties. The aim of textile researchers is to correlate these objectively measured properties such as bending and compression properties to subjectively assess properties such as drape. Successful methods and parameters are able to represent subjective and visual properties including drape (the property studied in this research). So, it was found that defining these properties, the principles of measurement and some commercially available objective measurement systems are of importance (Bishop 1996).

## **2.2. Physical properties**

### **2.2.1. Fabric construction**

Woven and knitted fabrics are conventional fabrics used in apparel manufacture. Both of them have different structures and varied methods of production.

In the **Woven Fabric** category, plain, twill and satin weaves are the basic types of woven fabric construction.

The plain (or tabby) weave, is the simplest type of weaving. They have a smooth surface. They have low tensile strength due to its high crimp; more wrinkle ability than other types and the lowest absorbency behaviour. plain weave could be altered to make different types of weave such as ribbed, basket weave, or seersucker fabric (Elsasser 2005).

In the twill weaves, the most distinctive appearance is the diagonals on the surface, which looks like a series of steps. Twill fabrics are woven closely because of the low number of entangled yarns. They have high tensile strength and abrasion resistance. Compared with plain weaves, they are softer, more flexible, give better drape behaviour, better wrinkle recovery, high resistance to stains and easy stain repellence. There is a texture dominant on the surface. The appearance of both twill fabric sides are similar due to the reverse of twill lines at the back (Elsasser 2005).

Satin weave uses low twisted filament yarns. It is used in making dresses, linen, lingerie and draperies. This structure allows either the warp or weft yarns to pass over four or more of the other (sometimes 12). Satin fabrics

have smooth appearance due to the long floats. The few entangled filament yarns with high thread counts allow them to be interlaced compactly, which causes the lustre or glossy appearance. Due to the threads long pass, they are capable of shredding and wearing easily by abrasion. Selecting high thread counts with appropriate fibres improves the endurance. Satin weave with high thread counts has good resistance to wind. Satin weave with a low thread count is more flexible and resistant to wrinkling but may have yarn slippage. Soil spreads easily due to its smooth surface. It is used as apparel lining due its easy sliding over other surfaces and because of its softness (Elsasser 2005).

**Knitted fabrics** are formed by the implementation of manual or mechanical applications through the process of producing loops by one or more yarns with one needle or more. Fibre type, yarn properties, the method of production, needle specifications and the stitch size, formation and pattern affect the visual and mechanical properties of knitted fabrics (Corbman 1983; Elsasser 2005).

The gauge is one of the most important parameters in knitted fabric production. It is the number of needles per inch metric, which affects the number of stitches per inch square. It determines the fineness or density of the fabric, and the closeness and compactness of stitches (Corbman 1983; Elsasser 2005).

Knitted fabrics are classified according to the fabric structure, method of construction, machine used and number of guide bars on a machine. There are two main types weft knit and warp knit. In the weft knit, the loops are interlocked in the filling or crosswise direction. Each course is built on top of the other. The adjacent needles draw a yarn from the creel attached to the machine. They are operating independently to one another. All stitches per course are produced by one yarn. There are three categories in weft knit: Jersey, rib and purl. Double, interlock stitch and plain/single/jersey knit are variations of weft knit structures (Corbman 1983; Elsasser 2005).

The basic stitch types used in **weft knitting** are plain, purl/reverse, rib stitches. **Plain/single/Jersey knit** has a distinctive face and back. It is formed by interlocking stitches in the same direction on the face and a series of semicircular loops on the back. It stretches both length- and cross- wise directions out of shape. It has poor dimensional stability and curls at the selvages. **Purl knit** is a double-faced fabric. It is formed from alternate rows of knit and purl stitches. They interlock as semicircular loops, in the crosswise direction. It has a bulky behaviour, stretches in both length and cross wise direction and does not curl at raw or cut edges. **Rib Knit** is a double-faced fabric with vertical ribs on both sides. It is produced from alternate plain and purl stitches, which interlock in opposite directions in the lengthwise direction. It stretches a little in the lengthwise direction, but has

high extension and elasticity in the crosswise direction and does not curl at raw or cut edges (Corbman 1983; Elsasser 2005).

**Double knit** is a variation of the rib knit. Both sides have fine ribs in the lengthwise direction. The face and back has the same appearance. They are strong and durable. They are heavier and have more body than single jersey. They do not stretch or curl at cut edges. They have good stability and shape retention. **Interlock stitch knit** is characterised by fine ribs in the lengthwise direction on the face and back. It looks like as if two separate 1×1 rib fabrics are interlocked in one fabric. **Weft knit variations** may be produced in jersey, purl or rib knit or by combining any or all of them (Corbman 1983; Elsasser 2005).

In warp knit, the loops are interlocked in the lengthwise direction. Parallel yarns are used to produce one stitch per course and every yarn makes one stitch per course. All stitches are produced in each course simultaneously by the movement of the needles (up) at the same time.

Milanese knit, Raschel knit, kettenraschel knit, tricot knit and weft insertion warp knit are different types of warp knitted structure (Corbman 1983; Elsasser 2005).

### **2.2.2. Weight**

Fabric weight could be measured for unit area or length (running metre). In the first method, the weight of known area is measured. This method is easier for fabric description as the second needs explicit explanation because the weight of fabric length will be affected by its width. Fabric sampling, cutting, accuracy of weighing and conditioning must be considered. Error of area measurement and cutting should not exceed  $\pm 1\%$  (British Standards Institution 2005, Booth 1968).

### **2.2.3. Cover factor**

This is the extent to which an area of a fabric is covered by the yarns used. This could be measured in the warp and/or weft directions. Cloth cover factor could be measured as well. High cover factor values produce stiff and low drape fabrics. However, yarn count, twist factor, fibre and other properties should be considered (Booth 1968).

## **2.3. Mechanical properties**

### **2.3.1. Compression**

#### **2.3.1.1. Thickness**

Fabric thickness is one of the most important factors affecting its warmth, heaviness and stiffness properties. Basically, fabric thickness is the distance between two plane parallel plates (presser foot and anvil) when they

encompass the material tested which is subjected to a known pressure. In this test, the shape and size of both presser foot and anvil, applied pressure and velocity of presser foot are to be considered. The ratio of a circular (usually) foot diameter to fabric thickness should not be less than 5:1. The circular anvil's diameter should be greater than the presser foot by at least 5 cm (Saville 1999).

Using low pressure such as lower than  $0.25 \text{ lb/in}^2$  in testing thickness produces values similar to human eye evaluation because of the minor compression at this level of pressure. Moreover, the presser foot should be lowered with slow velocity and carefully. A clock-type gauge is used to read out the thickness measured on a tester, unless a digital tester is employed. This method of measurement is called a "Contact method" (Booth 1968).

During pressure application, three stages for resistance to compression take place. First, the individual fibres protrude from the fabric surface are compressed, followed by inter-yarn and/or inter-fibre friction, then lateral compression of the fibres themselves. The second stage is more responsible for fabric handle. Soft fabrics have a faster transition between stages one and three.

A visual or non-contact method could be used as an alternative measurement of thickness. This method does not use physical contact with the fabric surface. As most fabrics have loose fibres protruding above the surface, one of the major risks in this method is the determination of the surface start accurately which is operator dependant (Saville 1999).

#### **2.3.1.2. Hardness**

This is a measurement of fabric resistance to compression. It is presented by the relation between thickness and pressure. This is calculated as the ratio of difference between two thicknesses measured at two different loads to the difference between loads (pressures) applied to the sample measured (Peirce 1930).

#### **2.3.1.3. Compression modulus**

Another measure of fabric compactness is the "Compression modulus". This is calculated as the ratio of stress (difference in pressure) to strain (difference in thickness divided by the original thickness) which produces Young's modulus. In other words, it is calculated from the "Hardness" multiplied by the thickness. It shows the degree of hard fabric surface irregularities (Peirce 1930).

#### **2.3.1.4. Density**

This is a third measure of fabric compactness. It is calculated as the area weight of fabric divided by the thickness. This is affected by gaps between fibres.

### **2.3.2. Tensile**

Basically, a tensile test measures the fabric strength which is considered as the main criterion of its quality. It is affected by different fabric features such as its construction and finish. Generally, conventional textiles have higher tensile strength than nonwovens (except parallel laid). Apparel fabrics need good strength properties to stand stresses applied in use (Saleh 2003).

A tensile test involves the application of a load to a specimen (under constant rate of loading or extension) in its axial direction causing its tension. This is expressed by gravitational units of force such as grams. The load used is preset according to the test condition and purpose. It could be conducted to measure fabric breaking length or breaking extension. However, in this study we were concerned with low stress mechanical properties, so tensile properties measured at low load were considered.

In this test, the load (stress) - elongation (strain) curve is used to calculate tensile parameters. The stress is the force applied to a material. The elongation is the increase in the sample length compared to its original length (they are proportional to each other). In other words it is the strain or percentage of extension. The elongation at the maximum load is an important tensile parameter (Booth 1968).

A load-elongation curve can be partitioned into three significant stages for mechanisms taking place. These start with inter-fibre friction, also called the initial decrimping region (producing initial high modulus), followed by decrimping (relatively low modulus is obtained), then the yarn extension region (Hearle 1969).

The term “extensibility” was proposed for measuring fabric resistance to extension which affects the subjective judgment of handle. The initial slope of a tensile stress-strain curve obtained from testing a sample is used to compare handle and bending properties. The extensibility is expressed by the ratio of tensile stress to strain (Young's modulus) (Peirce 1930).

### **2.3.3. Shear**

In this test, a sample is subjected to a pair of equal and opposite stresses acting parallel to one side of the sample and its area remains constant. Shear is the rotation of the warp and weft yarns from their original position (changing of the angle between the vertical and horizontal yarns). The forces acting on a fabric are extension forces in one diagonal direction and compression in the other diagonal direction. If the fabric has no resistance to the rotation of the yarns, there will not be a resistance to elongation. Shear deformation of fabric determines its behaviour when it is subjected to complex deformation in use. This property may affect fabric appearance positively or negatively (Hearle 1969).

A shear stress-strain curve is plotted as a result of this test from which shear parameters are measured including initial shear modulus, shear modulus and shear hysteresis. The “shear modulus” is the ratio of shear stress to shear strain. The recovery percentage after stress release is an effective influence on fabric behaviour. The shear stiffness (rigidity) is the force required for shear deformation.

Fabrics’ looseness degree (level) would affect their cutting and sewing. Very loose fabric which has low shear rigidity might cause pattern distortion during cutting, while very rigid fabrics with high shear rigidity would be difficult to form into a three dimensional shape without unwanted buckling as well as making it difficult to match patterns (CSIRO 1991). This property signifies fabric from thin sheet material such as paper. Cusick *et al.* in 1963 tested the physical properties of some commercial nonwovens and determined higher shear moduli than woven fabrics (Cusick *et al.* 1963).

### 2.3.4. Rigidity

Fabric rigidity is its ability to bend or flex under an applied force. It could be given by exerting bending or twisting forces on the tested specimen to obtain flexural rigidity or torsional rigidity respectively. Measurement methods of this property could be classified into two main categories in which either deformation or deforming force is measured.

#### 2.3.4.1. Measurement of deformation

##### 2.3.4.1.1. The cantilever test

In 1930, Peirce described an instrument called a “Flexometer” developed by “British Cotton Industry Research Institution” to measure fabric stiffness (see Figure 2.1). The current version of this instrument is the “Shirley stiffness tester”. This instrument is based on the cantilever principle and is used to measure the overhanging length and angle of deflection of a tested rectangular specimen. The bending length  $c$  (the length of the fabric that bends under its own weight to a definite extent) was calculated using Equation 2.1.

$$c = l \cdot f_1(\theta) \quad 2.1$$

where:

$l$  is the overhanging length of the tested material

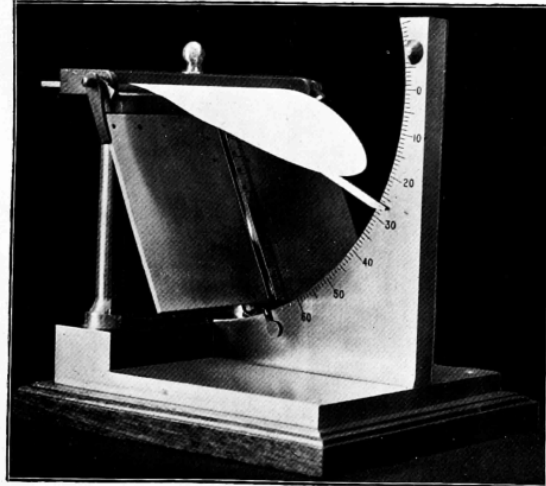
$$f_1(\theta) = \sqrt[3]{\left(\frac{\cos 0.5\theta}{8 \tan \theta}\right)}$$

$\theta$  is the angle of deflection.



Fabric flexural rigidity is the external bending force required per unit fabric width to cause alteration to its curvature. This is calculated by multiplying the fabric weight by  $c^3$ .

Since, the bending length describes the way in which a fabric drapes and depends on its fabric stiffness (resistance to bending) and weight. Therefore the stiffer the fabric is, the higher the bending length is.



**Figure 2.1** Flexometer (reproduced from (Peirce 1930))

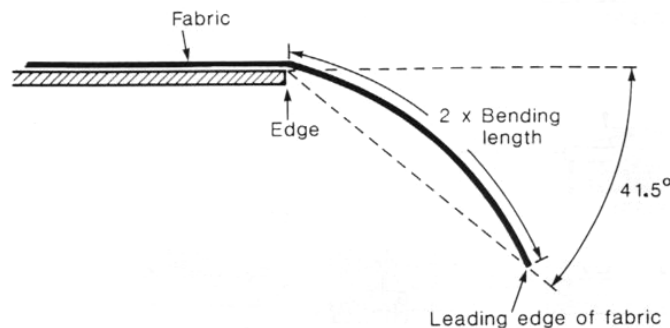
Peirce mentioned that the difference between the face and back bending length, due to slight curl and/or twist which would take place in some fabrics due to their weave structure or the finishing strain, would be eliminated by averaging their bending length values. He stated that the bending length should be measured in both warp and weft directions and it is not important to measure it in the bias direction. The stiffness of the fabric is governed by the warp and weft directions' stiffness.

Peirce tested a range of fabrics (around 50) with different stiffness behaviour. He reported that the measured mean bending length using the Flexometer (in standard conditions) ranged between 1.81 cm (for soft fabrics) and 6.35 cm (for stiff ones). This range increased to be between 1.6 to 8.5 cm by adjusting the overhang length and angle of deflection.

This is the standard method of Pierce for measuring fabric bending length in which a rectangular cantilever specimen is employed. It is assumed that the tested sample is flat when unstressed and bends under its own weight to produce the angle of deflection. Although, some samples tend to curl or twist and others make 90° angle of deflection with the horizontal plane which causes difficulties in measuring the bending length using the original Flexometer. Therefore, some adaptations have been developed to the Flexometer and the measured samples to overcome their unsuitability to the original apparatus, for example a weight could be added to very stiff fabric, this test was called "weighted rectangle", a large circular or square sample

could be used to measure flimsy fabrics. Also the bending pear method is one of the developed adjustments to the sample. The selection of the applied procedure is dependent on fabric stiffness. Each method has its correspondent applied formula for calculating the bending length.

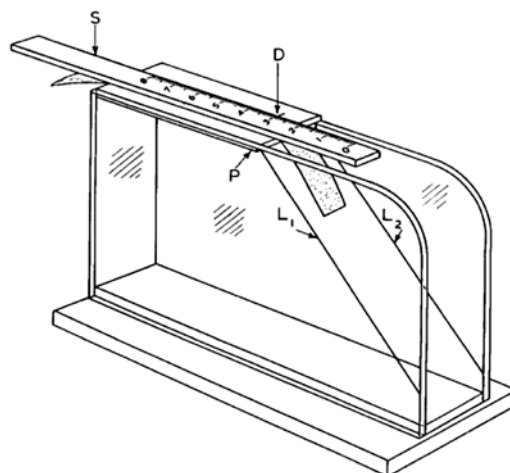
There are bending meters available and based on the cantilever principle such as the Shirley stiffness tester and FAST 2 bending meter. However they have different methods for obtaining the bending length value. In these tests, a rectangular specimen is mounted on a horizontal platform in its length direction. This position of the sample enables it to overhang and bend under its own weight. The operator moves it forward until its tip reaches a plane which passes an angle of  $41.5^\circ$  from the horizontal plane. At this angle, the bending length is half the overhanging length (see Figure 2.2)



**Figure 2.2** Schematic representation of the measurement of the bending length based on the cantilever principle(reproduced from (CSIRO 1991))

#### 2.3.4.1.1.1. Shirley stiffness tester

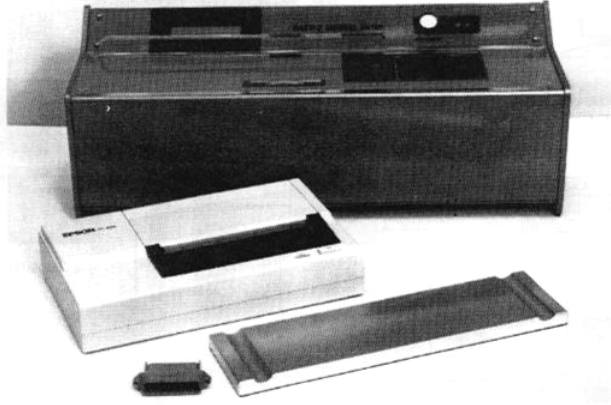
Using this apparatus, the operator can calculate the bending length and flexural rigidity from the overhanging length of fabric. The bending length is the overhanging length divided by two; flexural rigidity is obtained from the bending length and the fabric mass.



**Figure 2.3** Shirley stiffness tester (reproduced from (British standard Institution 1990) )

2.3.4.1.1.2. *FAST 2 (bending meter)*

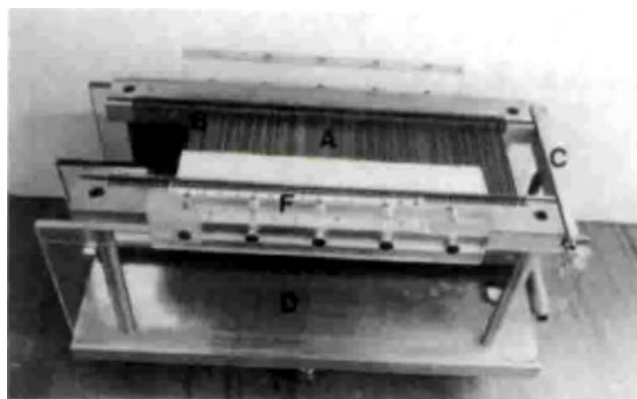
The FAST 2 meter's principle for measuring bending length is the same as the previous manual-bending tester (Shirley) (Figure 2.4). However, the bending length is shown on the display monitor directly.



**Figure 2.4 FAST 2 - bending meter (reproduced from [CSIRO 1991](#))**

2.3.4.1.1.3. *Russell test*

Russell developed an alternative method of measuring the fabric cantilever bending length. This method was adapted for testing slippery and easily deformed fabrics as they would be cockled when measured using Shirley or FAST testers due to sliding a support body over the fabric. A comb Sorter apparatus used for the measurement of fibre length distribution was adjusted for laying the strip tested on its faller bar (A) in Figure 2.5. To measure the fabric bending length, the faller bed is lowered until its tip intersects with a plane making  $41.5^\circ$  with the horizontal plane and the overhanging length is read from scale F (Russell 1994).



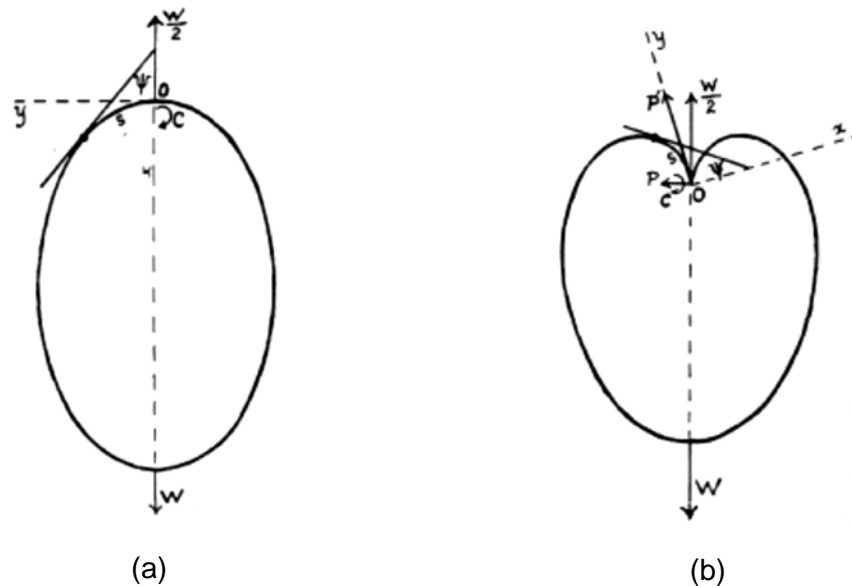
**Figure 2.5 Russell test for measuring fabric bending length (reproduced from (Russell 1994))**

2.3.4.1.2. *Hanging loop tests*

These tests are from the series of alternative tests developed by Peirce in 1930 for measuring fabrics unable to be tested using the standard

Flexometer. The specimen is distorted into one of loop shapes such as ring, pear or heart loop, supported at one point and hung vertically. These tests were developed to increase fabric resistance to bending when it is exposed to greater bending force than that of the cantilever method which makes it measurable.

In these tests, both ends of the strip are held together using a clip to form a loop, and then allowed to hang under the grip to produce angles  $180^\circ$ ,  $360^\circ$  and  $540^\circ$  (see Figure 2.6). These three loops are pear, ring and heart respectively. The hanging heart loop test was developed for testing very limp and soft fabric bending lengths which bend to a right angle on the Flexometer. This method reduces fabric curl in the test and lets the tested strip bend freely under its own weight. Therefore, it was intended to increase the amount of bending to make the resistance to bending measurable (Peirce 1930).



**Figure 2.6** Examples of loop test form (a) Ring loop, (b)Heart loop(reproduced from (Peirce 1930))

Peirce determined the standard sample dimensions used on the Flexometer to be (6 inch length  $\times$  1 inch width). Regarding the heart loop test, he stated that it would be carried out using a strip of 10 cm or less. Later in the paper he mentioned that a fixed length of strip 15 cm would be suitable to test soft fabrics (using a table from which the bending length would be obtained directly from the loop height which is less laborious).

Winn and Schwarz studied the effect of the heart loop test strip length (the circumference of the loop) on the obtained bending length value. They found that there is a critical length for the strip length. An increase in this length will change the bending length; however any decrease will not have an impact. The bending length remained constant for specimen lengths between 12.5

and 37.5 cm. It was noted that stiffer fabrics would require longer samples than less stiff fabrics. In this range the operator could select his sample length to carry out accurate experiments (Winn and Schwarz 1939b). Afterwards, the hanging heart loop test was carried out by Abbott using a strip of 20 cm (Abbott 1951).

Winn and Schwarz reported that the formula of the heart loop test is simple compared to the pear loop. They reported from previous studies that the heart loop test is preferred for very limp fabrics than stiff fabrics and vice versa (the pear loop for stiff fabrics). Although, the heart loop test could be used satisfactorily within a wide range of fabrics with variable thickness, hardness and stiffness. Besides, the heart loop test showed the best range of measurement for all types of materials compared with other tests (Gurley stiffness tester, Schiefer Flexometer and Drapeometer measurements) (Winn and Schwarz 1939b).

#### 2.3.4.1.1. Bending loop test

Stuart and Baird developed a measurement method of fabric bending length using a loop of a material. In this test, a strip is laid on a flat and non-adhesive surface and one end is bent to meet the other one to form a bent loop shape (see Figure 2.7). The sample length was 5 times its width. It was suggested to use this method with soft fabrics as they were measured more accurately using the loop tests than the cantilever. This is the simplest style of a fabric loop test as it is very quick and easy to be carried out (Stuart and Baird 1966; Stuart 1966).

The height of the loop is substituted in a formula to obtain the bending length of a strip (see Equation 2.2):

$$BL(loop)cm = 1.1 * Lh(cm) \quad 2.2$$

where:  $Lh$  is the loop height which is the distance between the highest and lowest portions of the loop on the vertical axis between the neutral axes (assumed to be at the sample centre) (see Equation 2.3).

$$Lh(cm) = \text{height of the loop above the the flat surface}(cm) - \text{Thickness}(cm) \quad 2.3$$



**Figure 2.7** Bending loop (a) A loop of neoprene, (b) loop shape as plotted by a computer (reproduced from (Stuart 1966))

#### 2.3.4.1.2. Cassidy *et al.* Bending box

Cassidy developed a tester called a “Bending box “ which would better meet the requirements of objective measurement related to knitted fabric performance in handling during production, as the previous used methods lack the reproducibility for those knitted fabrics which tend to curl or twist and/or there are difficulties in application of the results to the performance of fabric in garment assembly. Moreover the tester was easy to use and inexpensive.

This tester was based on folding the sample to form a loop, the higher the loop is, the stiffer the fabric is. Three initial experimental trials were carried out in order to investigate the degree of this method’s reliability. The meter proved a more dependable measurement of knitted fabric bending length than the Shirley tester in terms of reproducibility. The comparison between the results of KES-F bending tester and the method results showed similar identification for fabric stiffness (Cassidy *et al.* 1991).

#### 2.3.4.1.3. Cassidy Instron test for bending

Cassidy, C. developed a system for measuring fabric bending length. This method was developed due to the limitations in every individual common method used i.e. cantilever and loop tests. Therefore, she worked on combining the advantages of both styles. A tensile tester (Instron 4302) was used in a compression mode to produce a dynamic loop. The tested sample was allowed to generate the first fold and the distance between it and the second loop was measured using the manual cursor settings. The bending length was calculated from the load displacement graph which was obtained by the PC attached to the tester (Cassidy 2002).

#### 2.3.4.1.4. Planoflex

Dreby developed an instrument to measure the required angle for producing a wrinkle in a tested sample. In this test, the specimen measured is mounted on a frame which allows lateral displacement of one end of the fabric to take place. The angle measured is a stiffness parameter. The values of both sides are averaged (Abbott 1951).

#### 2.3.4.1.5. Ordinary beam test

An inverted self-supported U-shaped specimen was originally laid horizontally against a smooth coordinated platform and was proposed by Hall to compare fabric stiffness.

#### 2.3.4.1.6. Hanging strip

A sample is supported vertically using a clamp which is connected to a graduated disk. The sample is allowed to make a standard angle of 22.5

degrees with the horizontal plane and the displacement is read from the disk (Schwarz 1939).

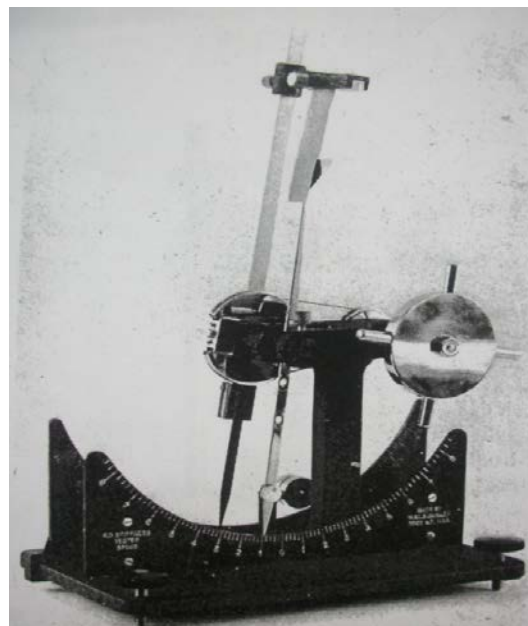
#### 2.3.4.2. Measurement of deforming force

This is a measure of the resistance offered by the sample to bending or to twisting. According to Schwarz, in bending tests, it is important to consider the weight in this test, and whether to correct for or eliminate it. This is to determine that the deformation took place only due to its weight or to apply a definite force and measure both of them. There were several methods proposed for measuring the deforming force subjected to a sample tested (Schwarz 1939).

##### 2.3.4.2.1. Gurley stiffness tester

This instrument supports a tested sample vertically at its upper end by means of a rotating arm (see Figure 2.8). The force required to bend and slip the sample's free lower end over a vane is measured. A weighted pendulum-type vane is used to measure the strip deflection. The stiffness is calculated by multiplying the read value by a factor. Variables such as sample size, thickness and the vane's weight would affect the results. Besides, the tester was not found to be of high precision for soft fabrics which had values at the minimum range of the instrument. However stiff fabrics showed higher stiffness than its values using the hanging heart loop test (Winn and Schwarz 1940b).

Saxl described an instrument with a similar principle. However, the strip was supported horizontally on a platform and would be bend to take a U shape (Schwarz 1939).



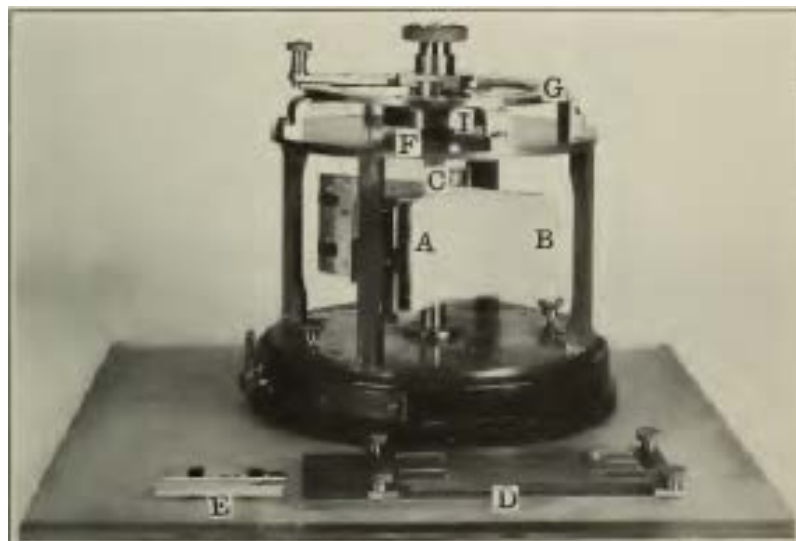
**Figure 2.8** Gurley stiffness tester(reproduced from (Winn and Schwarz 1940b))

#### 2.3.4.2.2. Schiefer Flexometer

This instrument measures the force required to bend (fold) a pair of standard samples mounted on two plates placed opposite to each other vertically by means of a spring to a definite angle  $\theta$  (see Figure 2.9). A pair of samples are used for symmetry and to increase the torque exerted from the sample on the plates during folding (due to its resistance to folding and bending). The angle of deflection (folding) between the two plates is dependent on and calculated from the sample thickness (using an equation provided).

The force required for folding the specimens through a definite angle between the plates, the recovered force when they are allowed to unfold, and the force lost (difference between folding and unfolding forces) are measured to obtain three stiffness parameters including flexural force, resilience (expressed as percentage of the folding force) and hysteresis respectively.

This instrument results were similar to the results to those of the hanging heart loop and Gurley stiffness tester (Schiefer 1933).



**Figure 2.9** Schiefer Flexometer(reproduced from (Schiefer 1933))

#### 2.3.4.2.3. Munzinger Impact test

Munzinger used a type of ballistic pendulum instrument to measure fabric stiffness. The sample tested is supported vertically in a swinging pendulum path and allowed to bend in it. The difference between the distance passed by the pendulum with and without a mounted strip beyond its lowest point was calculated and determined as a measurement of stiffness. This energy difference was absorbed by the strip (Schwarz 1939).

#### 2.3.4.2.4. Searle pendulum test

This test was proposed for measuring fabric stiffness. In this test, two torsion pendulums (rotating in opposite directions) are arranged to hold both ends of



a tested strip in a vertical position. The force required to bend the held strip is then measured. The flexural rigidity is calculated from the period of oscillation when the pendulums are allowed to rotate while the strip is mounted (Schwarz 1939).

#### 2.3.4.2.5. Twisting rigidity

Mori and Lloyd designed an apparatus to measure simultaneously, the torque and the in-plane load caused by twisting a fabric supported vertically between upper and lower jaws. The raw data were presented as torque (twisting moment), twist and in-plane load twist hysteresis curve. The twisting rigidity could be measured from the initial slope of this curve (Mori and Lloyd 1994).

#### 2.3.4.3. Relation between methods of measuring fabric stiffness

Peirce carried out a comparison between 7 different methods developed by him in 1930. He stated that this comparison was limited by fabric variability, changes in tests conditions, effects of handling the fabric during the test, observational error and no one fabric being applicable for all methods. However, tests were carried out for investigating the validity of formulae used, it was recommended by him to apply one method in the aim of doing direct/close comparisons between fabrics (Peirce 1930).

Schwarz *et al.* published a series of papers concerned with “Technical evaluation of textile finishing treatments”. These studies focused on different methods of measuring fabric stiffness, as the need for an objective method which could be carried out in the laboratory and was highly correlated with the subjective assessment of fabric handle was of great interest from both manufacturers and consumers at that time. They looked for a sensitive method in measuring fabric stiffness to differentiate between differences in finishes (Winn and Schwarz 1939a).

Firstly, they used the Spearman rating system as they thought it would be a reliable statistical tool to study the correlation between four different methods for measuring fabric rigidity. They did not expect a complete agreement between different systems. This incomplete agreement was specially expected for low sensitivity instruments for fabric rigidity and would be expected for other reasons such as the inherent variability of textile materials and because of difference in tests processes and procedures, and other differences and complexities. They reported that bending length and modulus correlation of 88% was not expected in normally variable textiles and they were not surprised for correlations between 30-60%, as they thought high correlations would exist only due to measurement resulting from a physical test and would not be expected if mathematical calculations are involved (Winn and Schwarz 1939b).

Later, they used the Kendall rank correlation coefficient instead of Spearman rating systems as they thought it has higher efficiency in studying such correlations. Despite their opinions, they found similar correlation between methods. In that study and the previous one they ranked the values of fabric stiffness obtained from the grand average (which is the mean of face and back in each direction) (Winn and Schwarz 1940a). In the following study, they did not compare the methods with each other as they did before, but they used the heart loop test as the basis of comparison as it would produce values with weight or without weight correction and it does not include external force to bend the fabric.

The analysis of variance was introduced as a statistical method to investigate the variation in finishing different types of fabric using different treatments and the t-test was proposed to determine the test methods' sensitivity to differentiate between fabrics' stiffness (Winn and Schwarz 1940a).

In further work, they suggested that comparison between different methods of measuring fabric stiffness. Using a correction factor based on fabric weight and thickness of the tested fabrics was recommended, as different methods would be based on different principles (for example some would bend the fabric under its weight and others not). Therefore there is a need to take these variations of tests into account (Winn and Schwarz 1940b).

Abott in 1951 compared five different methods of measuring fabric stiffness with the subjective assessment of stiffness which was considered by him as the standard method. The geometric mean of the lengthwise and crosswise directions was used as the representative value for each fabric bending length.

The compared parameters were the cantilever *BL*, heart loop *BL* and *BR* and the values of the Schiefer Flexometer, Planoflex and Drapeometer. All of them ranked the fabrics in approximately the same order. The Kendall coefficient was applied to measure each method's correlation with the subjective assessments. All these methods except the Drapeometer showed significance correlations with the subjective rating of fabric stiffness, which means that they are reliable in measuring fabric stiffness and there is a strong relation between them and the subjective assessment. However, the Pierce cantilever flexural rigidity had the highest rank correlation with the subjective assessment (Abbott 1951).

A study followed this investigation to compare Tinius Olsen's stiffness tester (measures the fabrics stiffness by measuring the applied load for bending a sample to 60°) with the Pierce stiffness tester - the measurements were carried out in the warpwise direction to eliminate as many variables as possible, in terms of:

- Similarity or relationship using the correlation coefficient and the best line fit (trend line) equation showing the quantitative relation between the two methods.
- Precision or reproducibility employing the average standard deviation SDEV and coefficient of variation CV (relative precision) of tested fabrics using each method. A small relative spread is expected from a precise instrument. However, Tinius Olsen SDEV average was 3 times Pierce's, their CV were the same, which means that there was a little difference between them with respect to the relative precision of the readings about the average.
- Sensitivity or relative ability to discriminate among fabrics of varying degrees of stiffness was carried out using the SDEV and CV of each method average to show how much variation exists from the method average. A sensitive method shows high SDEV and CV and means that different degrees of stiffness are registered by a spread in the values greater than that attributable due to experimental error.
- Discrimination level (Sensitivity index SE) shows the ability of a method to discriminate between fabrics with different stiffness.  $SE = \sigma_a^2 / \bar{\sigma}_w^2$ : where  $\sigma_a$  is the average SDEV of a method,  $\bar{\sigma}_w^2$  the overall average standard deviation (the reproducibility among the specimen stiffness values for a fabric). This SE was not statistically different between the two methods.
- Dependability of the test method. It includes the two major sources of variability-inherent operator variability and differences between operator.
  - a) Inherent reproducibility is the influence of an operator differences on the results. In other words, this is the ability of an operator (precision) to reproduce his own results. One operator's reproducibility was 10% on the Tinius Olsen and 14% on this Peirce tester for his overall fabric average at the 95% probability level.
  - b) Overall reproducibility is the operator average from the overall fabric average.
- Ease of operation and speed of obtaining results: if the measurements obtained by both machines are equally reliable, reproducible, and discriminating, then these two factors should be used to judge between two instruments.
- The fabric range is able to be tested on the apparatus
- Mechanical failure or malfunction: If the machine must be checked before each sample is tested; and repairs frequency should be taken into consideration.

- The time necessary to place the sample on the apparatus, test it, and remove it from the instrument. The Peirce tester was approximately 6 times faster than the Tinius Olsen instrument (Hynek and Winston 1953).

Stuart and Baird introduced their loop test to measure the bending length as an alternative method for the Pierce cantilever. Theoretical comparison suggested that their loop test produces higher values than the Cantilever does which is against the experimental results except for the soft fabrics. This difference between the two methods was more obvious in soft felts than in woven fabrics because of the lower deviation of the latter (woven fabrics).

Comparison between the two methods was carried out in terms of significance, difference and variability. There was no significant difference at the 5% probability level which means that they produced similar results. The variance of the Shirley was less than the Stuart and Baird loop (Stuart and Baird 1966).

Kalyanaraman and Sivaramakrishnan in 1984 studied the efficiency and validity of their electronic instrument based on the cantilever principle for measuring fabric stiffness. This study was based on comparing the new device results with results obtained from the Shirley stiffness tester. It was found that the new instrument applied the principle reliably but it was not more accurate than the Shirley tester. But, they stated that their device has some merits over the manual Shirley stiffness tester as quick and easy measurements and there was a lower dependence on the operator efficiency. The F ratio was used as a statistical tool for comparison in terms of determining the significance level of each method and was applied on a group of fabrics (Kalyanaraman and Sivaramakrishnan 1984).

Zhou and Ghosh compared 4 methods of measuring fabric bending length, namely: Pierce cantilever, heart loop, loop test 3 and 4 (as they were developed and called by them). They presumed that the results (different fabric stiffness values obtained from different methods) would not be identical as the measured parameters (*BL* or *BR*) depend on the test conditions and due to the nonlinear behaviour of the tested woven fabrics. There was a critical value for their developed loops 3 and 4 beyond which the bending length values will not be affected. The cantilever *BR* showed higher values than KES *BR*. However, the *BR* from heart loop, loops 3 and 4 were similar except for stiff fabrics. The difference between cantilever and loop tests increased with increased fabric stiffness (Zhou and Ghosh 1998).

### **2.3.5. Bending modulus**

This is the intrinsic stiffness of a fabric, as it is independent of the direction measured and is related to its thickness. In other words, it is an abstraction for fabric stiffness. It is called “Paperiness” and is a measure of fabric compactness and measures the degree of adhesion between fibres and

yarns. The bending modulus is calculated from flexural rigidity and thickness (Peirce 1930).

### **2.3.6. Friction**

Fabric resistance to motion is defined as its friction. Measurement of the coefficient of friction is based on pulling a mass block, across tested sample of fabric. This block is connected to a load cell which records the force needed to start and keep moving the block producing static and dynamic friction coefficients respectively (Saville 1999).

The coefficient of friction is the ratio of the force required to move the block to its weight. The frictional force could be plotted against the displacement. The selection of the block material is important as the coefficient of friction is affected by both materials of the block and the fabric. In measuring the static coefficient of friction “stiction”, a block is placed on a fabric mounted on a plane. The plane is adjusted until the block starts to slide. The coefficient of friction is  $\tan\theta$ , where  $\theta$  is the inclination angle of the plane. If an impetus is given to the block and the angle at which motion just continues is determined, the coefficient of dynamic friction could be measured (Saville 1999).

This was also used by Cassidy in her thesis. She used the load displacement graph produced on an Instron tester in a friction test to measure Coefficients of Static and Dynamic friction and Roughness Factor. In this test the sled and platform attached to the instrument were used to carry out the test. The standard sled was a sheet metal plate covered with foam. The platform is made of polished metal and has a locating pin on the underside of one end which fits into the bottom clamp housing directly under the cross-head of the Instron tensile tester and secured with a metal pin. There is a small metal pulley fixed to the platform which has negligible friction. She developed the sled to involve the minimal handling of the fabric samples. The highest peak of the frictional trace at the beginning of the movement was taken as the coefficient of static friction, and the mean between the peaks and troughs during motion was taken as the coefficient of kinetic or dynamic friction. The roughness parameter was also calculated by taking the difference between the troughs and peaks during the movement of the sled (Cassidy 2002).

### **2.3.7. Buckling**

Fabric buckling (such as bending of a sleeve or a trouser leg) takes place when an apparel is in use. Plate buckling is the simplest method for testing this property. This method was proposed for measuring fabric bending rigidity and frictional resistance to bending.

Grosberg showed that different cases of applied loads on a sample could be considered in which both tips are free, one tip is supported or both tips are supported. In the case of both sample tips being clamped the critical load is the ratio of bending rigidity to gauge length. Moreover, the return curve after buckling which presents cloth recovery from buckling could be considered (Hearle 1969).

In this test, a load-compression curve is plotted. A comparison between elastic material and cloth buckling showed that they have significantly different behaviour. In cloth buckling the load decreases with compression (in loading) and when the load is released the curve does not retrace the loading curve but showed marked hysteresis (Hearle 1969).

The relation between bending moment and the inverse of radius of curvature was first proposed by Eeg-Olofsson in 1959 (Hearle 1969). This plot was developed and used later by Kawabata in the pure bending test using KES-FB2.

## **2.4. FOM systems**

Peirce in 1930 launched what is called the “Objective measurement” of fabric properties by publishing his paper “The handle of cloth as a measurable quantity”. However over the past years, there has been gradual and continuous development of testing methods and national and international standards, which aim at reaching the optimum and most efficient measurements. This is to improve the applications included in all steps of production process of fabric and satisfy the needs of both manufacturers and consumers. Consequently, there is continual competition between organisations to improve FOM applications in textile industry quality control. There have been many objective methods developed for different purposes. They are used universally in physical testing and quality control in the clothing industry. These methods rely on national or international standards such as British Standards (BS), American Society for Testing and Materials (ASTM), and International Organization for Standardization (ISO). Kawabata evaluation system of fabrics (KES-F) and The Fabric assurance by simple testing (FAST) are the best-known methods for objective measurements available commercially (Bishop 1996).

### **2.4.1. Kawabata evaluation system of fabrics (KES-F)**

In 1972, Sueo Kawabata introduced the Kawabata evaluation system of fabrics (KES-F) by participation with the Textile machinery Society of Japan (Saville 1999). The main purpose of this system was to carry out fabric mechanical properties' identification and evaluation. Due to his work and experience in the field of fabric mechanical properties and the evaluation of fabric handle and attributes, he found an essential need to introduce a

system to measure accurately a group of sixteen fabric qualities instantly. These could be plotted on charts provided with these instruments. This system went through different developments to have a computerised and automated version with software to collect and analyse the output data. The tests are carried out using a sample of standard dimensions. The system produces stress(force)-strain plots resulting from the applied force in one direction and then it is released to apply it in the opposite direction. The plots show the hysteresis behaviour of a sample tested resulting from the energy loss during deformation.

The system consists of four instruments to measure the following properties:

- KES-FB1 measures Tensile and shear strength
- KES-FB2 tests fabric Pure bending
- KES-FB3 measures Compression properties
- KES-FB4 measures Surface friction and roughness

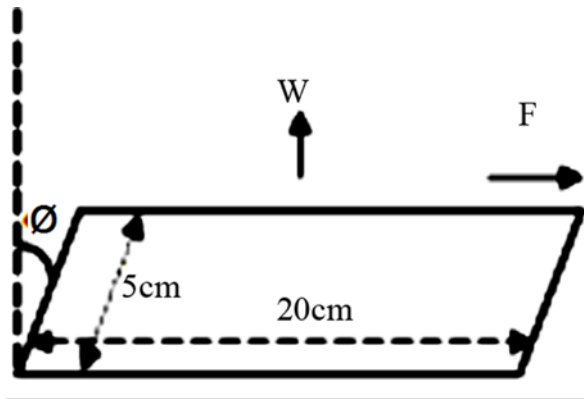
#### **2.4.1.1. Shear test (KES-FB-1)**

In this test, a sample of dimensions 5 × 20 cm is subjected to a constant tension of 10 gf/cm to maximum shear angle 8 degrees in its long direction and then the shearing motion is reversed to the opposite direction (see Figure 2.10). The relation between shear force - strain is detected during the test and plotted (see Figure 2.11). It is recommended to carry out this test before the tensile test because the tensile deformation is greater than shear deformation.

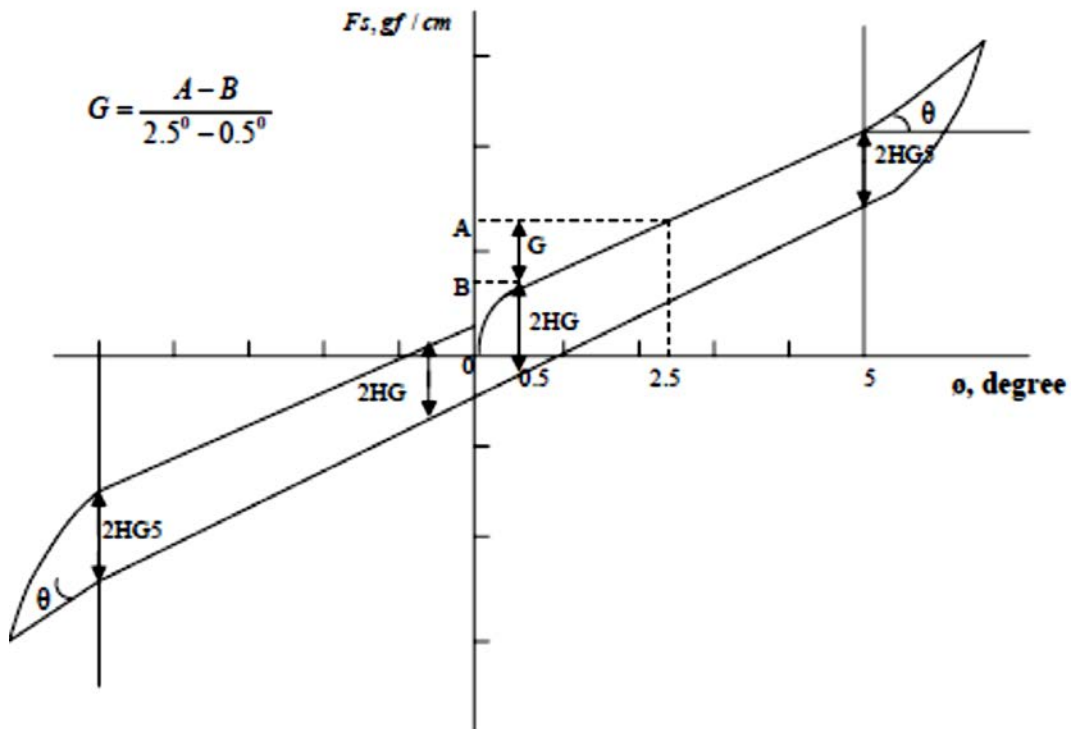
The following shear parameters are measured:

- **Shear stiffness (G)** (gf/cm.degree) is the slope of shear force-angle (strain) curve measured between 0.5° and 2.5°. Low values indicate less resistance to the shearing motion; corresponds with better drape.
- **Shear Hysteresis at shear angle 0.5° (2HG)** (gf/cm) is the width of the hysteresis loop at  $\theta = 0.5^\circ$ .
- **Shear Hysteresis at shear angle 5° (2HG5)** (gf/cm) is the width of the hysteresis loop at  $\theta = 5^\circ$ .

The average of these values for positive and negative curves in warp and weft directions are calculated.



**Figure 2.10** Shear test using KES-FB-1 (Pandurangan 2003)



**Figure 2.11** An example of Shear force-angle resulting curve, where  $F_s$  is the shearing force and  $\varnothing$  is the measured angle (reproduced from (Gider 2004))

#### 2.4.1.2. Tensile test (KES-FB-1)

A sample tested is subjected to a constant tensile force in one direction to reach the maximum tensile force 500 gf/cm (see Figure 2.12), the force is then released to recover to the origin position to obtain a pair of curves (a and b respectively in Figure 2.13) present the tensile force ( $F$ ) and strain ( $\epsilon$ ).



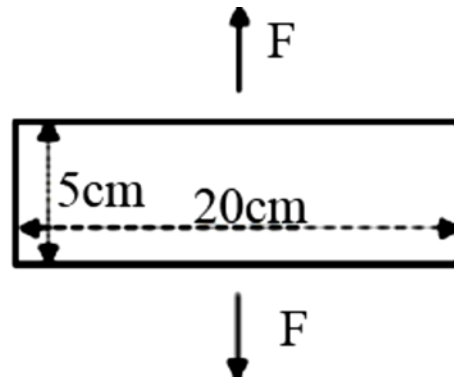


Figure 2.12 Tensile test using KES-FB-1 (Pandurangan 2003)

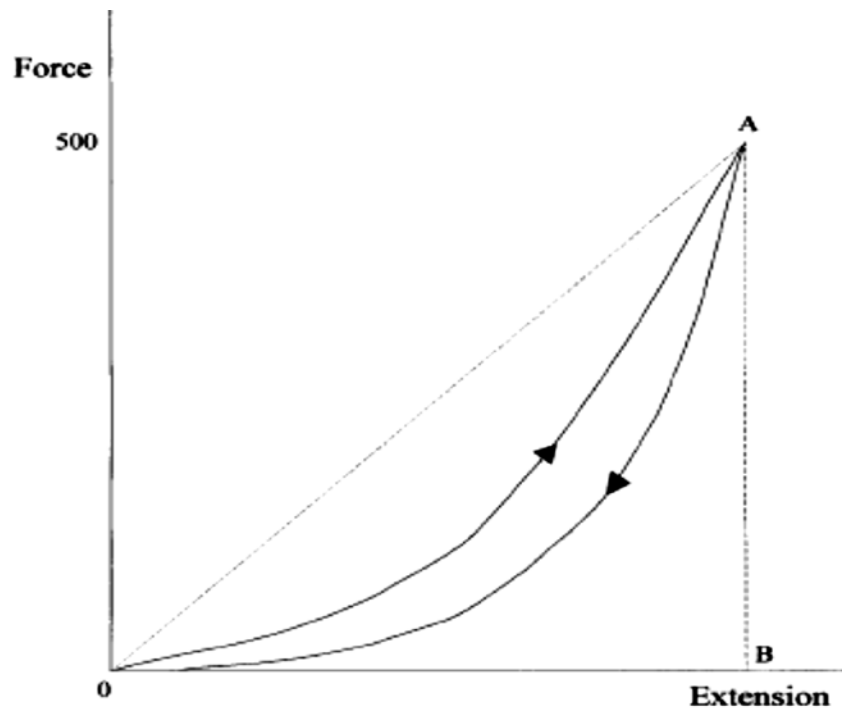


Figure 2.13 A Typical Force-Extension Tensile Curve of a Fabric (KES-F1) (reproduced from (Saville 1999))

From this plot, different parameters could be measured:

- **Tensile energy WT** (gf.cm/cm<sup>2</sup>) ( the work done while stretching the fabric until maximum force) is the area under the increasing load -strain curve.
- **Linearity of load-extension curve**(2.4) (see Figure 2.13)

$$LT = \frac{WT}{\text{Area of triangle OAB}} \quad 2.4$$

- **Tensile Resilience**(Equation 2.5)

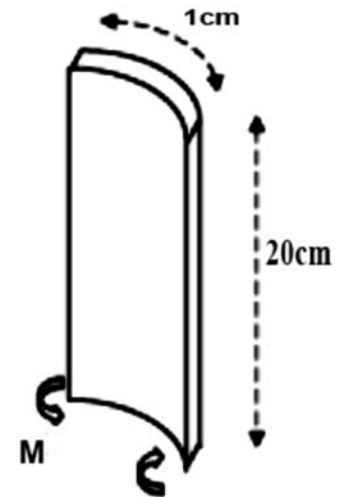
$$RT (\%) = \frac{\text{Area under load decreasing curve}}{WT} \times 100\% \quad 2.5$$

This measures the recovery from stretch when the applied force is removed. High values indicate great recovery from having been stretched.

- **Tensile strain or elongation EMT (%)** is the tensile Strain at the point A on the curve.

#### 2.4.1.3. Bending test (KES-FB2)

In this test, pure bending force is applied to the sample with a constant rate of curvature (K) 5 mm/sec in a range of curvatures  $-2.5 \leq K \leq 2.5 \text{ cm}^{-1}$  (forward and backward). Two chucks hold a sample, one is fixed and the other is movable to bend the sample (see Figure 2.14). The bending moment-bending curvature relationship is plotted (see Figure 2.15).

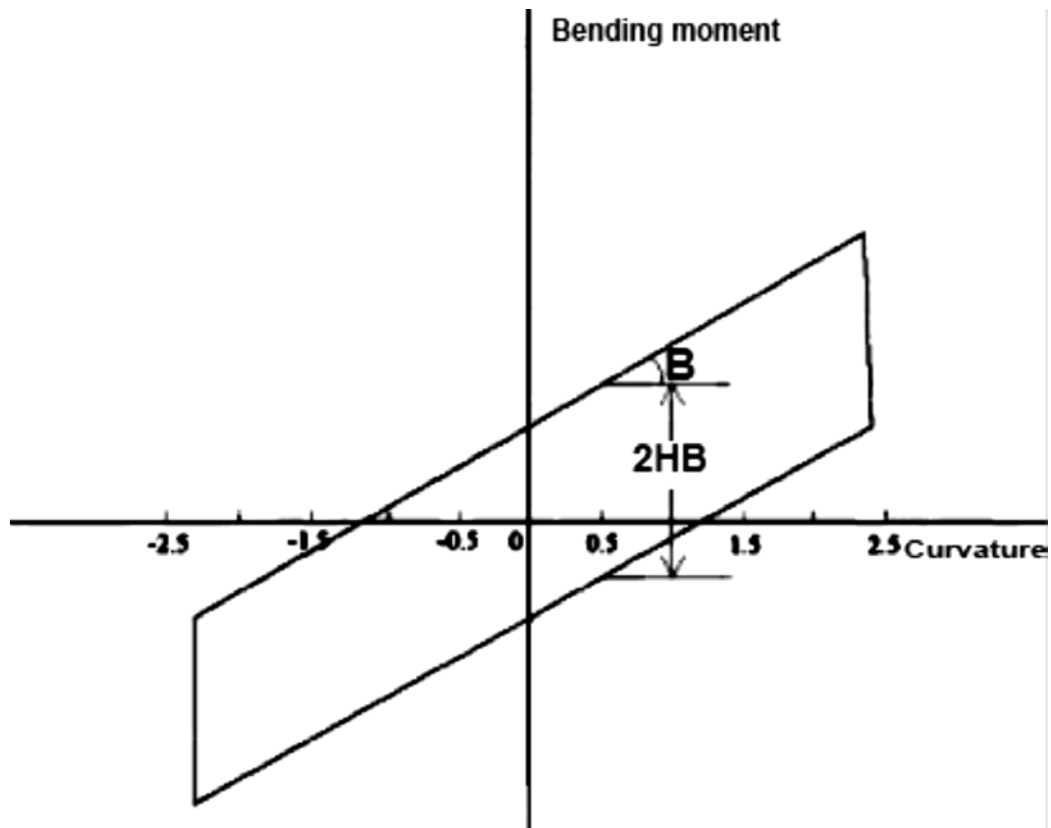


**Figure 2.14** Pure bending test (Pandurangan 2003)

The following parameters are measured:

- **Bending stiffness B** ( $\text{gf.cm}^2/\text{cm}$ ) is the slope of the bending moment – curvature curve between  $K = 0.5 \text{ cm}^{-1}$  and  $K = 1.5 \text{ cm}^{-1}$ . Higher B value indicates greater stiffness/resistance to bending motions.
- **Hysteresis of bending moment 2HB** ( $\text{gf.cm/cm}$ ) is the width of the hysteresis curve at  $K = 0.5 \text{ cm}^{-1}$

The average of two measurements for sample face inside and outside is calculated.



**Figure 2.15** Bending moment-curvature plot from pure bending test (Saville 1999)

#### 2.4.1.4. Compression test (KES-FB-3)

A sample tested is placed on a plate and the plunger moves downwards with constant rate of force 1mm/50sec until it reaches the preset upper limit of the compression force 50 gf/cm<sup>2</sup>, it then moves upwards to recover the compression (see Figure 2.16). The stress(pressure)-strain(thickness) curve is plotted (see Figure 2.17).

The following properties could be calculated as LT, WT and RC calculated in the tensile test:

- **Linearity of compression thickness curve LC**
- **Compressional energy WC (g f .cm/cm<sup>2</sup>)**
- **Compressional resilience RC (%)**: Higher value indicates a greater recovery from being compressed.

The **Thickness** (millimetres) is measured at 0.5 gf/cm<sup>2</sup>.

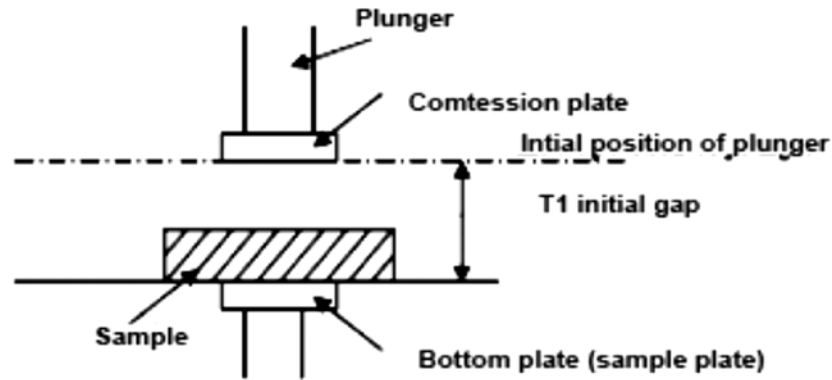


Figure 2.16 Compression test (Gider 2004)

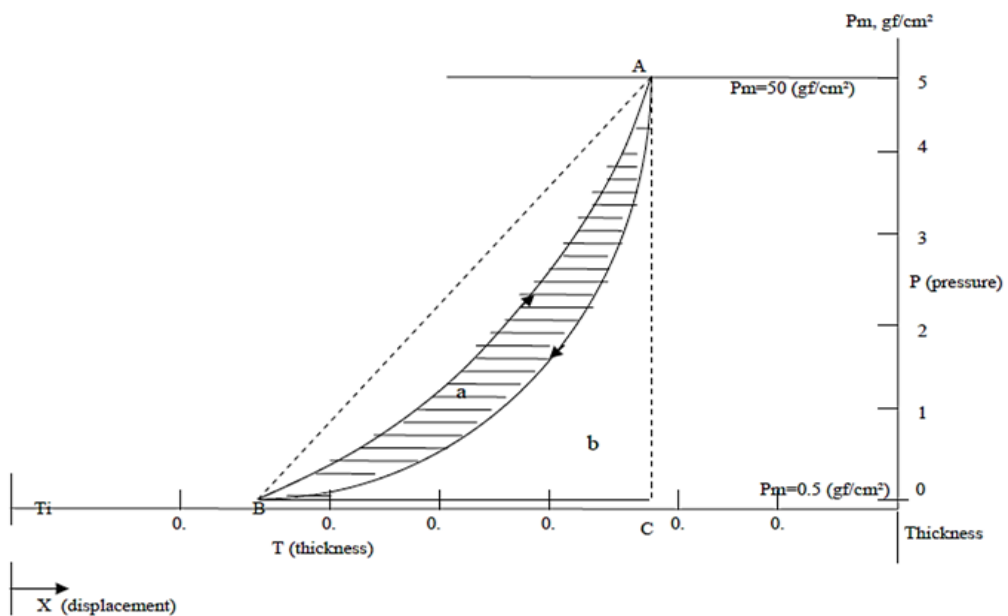


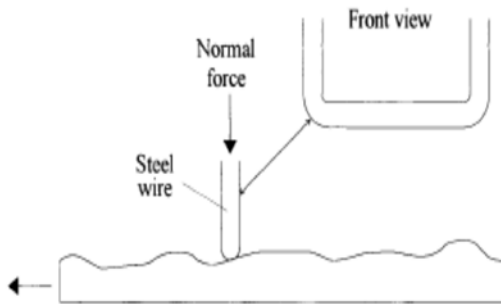
Figure 2.17 Pressure-Thickness curve resultant from compression test (Gider 2004)

#### 2.4.1.5. Surface Friction and Roughness tests (KES-FB-4)

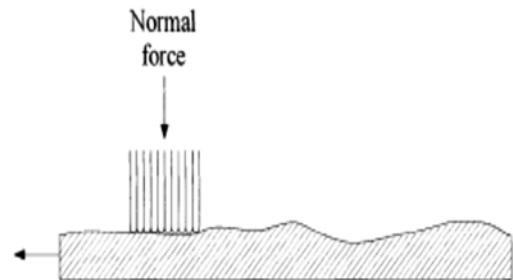
In these tests, a sample tested is placed horizontally on a plate. One of the sample's ends is fixed at a winding drum and the other end is connected to a tension device. The rotation of the drum moves the fabric at a constant speed 1 mm/sec.

In surface roughness (SMD) measurement, a contactor (of 0.5 mm diameter) designed to simulate the human finger surface is placed on top of the sample and makes a contact force of 10 gf (Figure 2.18) with the fabric. The displacement of the contactor is recorded while the fabric moves as an indicator of thickness variation to plot the height-distance curve. The SMD is the mean deviation of surface roughness and is measured automatically (Figure 2.20).

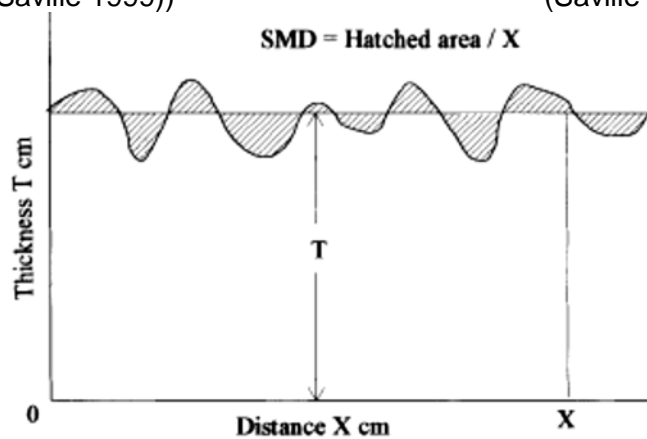
To measure the surface friction, a series of ten contactors similar to the previous one is used with 50 gf contact force to record the force required to pull the fabric past the contactors (Figure 2.19). Force (Friction)- A distance curve is plotted, from which the Mean value of coefficient of friction (MIU) and Mean deviation of coefficient of friction (MMD) are calculated (Figure 2.21).



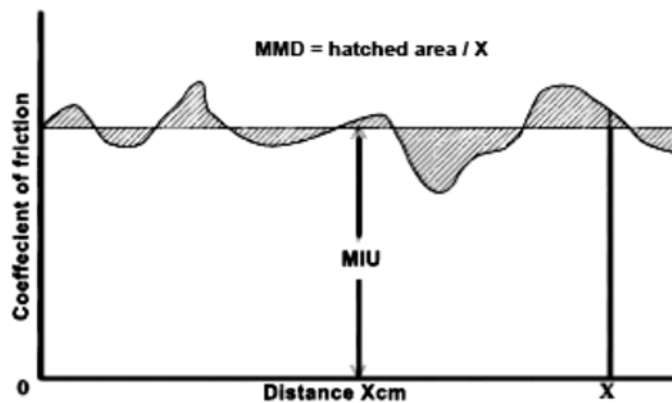
**Figure 2.18** Surface roughness measurement (reproduced from (Saville 1999))



**Figure 2.19** Surface friction measurement (reproduced from (Saville 1999))



**Figure 2.20** Surface thickness variation (reproduced from (Saville 1999))



**Figure 2.21** Surface friction variation (Saville 1999)

- **Mean value Frictional coefficient** (Equation 2.6)

$$MIU = \frac{1}{L_{max}} \int_0^{L_{max}} \mu \, dL \quad 2.6$$

where,  $L_{max}$  = the sweep length,

$\mu = \frac{\text{Frictional force}}{\text{The force applied by the contractor pressing on the fabric sample}}$ ,  $L$  = distance on fabric surface. **MIU** ranges from 0 to 1 with higher value corresponding to greater friction or resistance and drag.

- **Mean deviation of the coefficient of friction** (Equation 2.7)

$$MMD = \frac{1}{L_{max}} \int_0^{L_{max}} |\mu - \bar{\mu}| \, dL \quad 2.7$$

- **Surface roughness** (Equation 2.8)

$$SMD = \frac{1}{L_{max}} \int_0^{L_{max}} |Z - \bar{Z}| \, dL \quad 2.8$$

where  $Z$  is the vertical displacement of the contractor. High values corresponds to a geometrically rough surface.

The sixteen parameters measured could be normalised and plotted on the control chart developed (see Table 2.1) (Saville 1999).

**Table 2.1** Summary of properties measured using KES-F

Test	Property	Description	Units
Shear	<b>G</b>	Shear stiffness	gf/cm.degree
	2HG	Hysteresis of shear stress at 0.5 degree	gf/cm
	2HG5	Hysteresis of shear stress at 5 degree	gf/cm
Tensile	LT	Linearity of stress-strain curve	None
	WT	Tensile energy	gf.cm/cm <sup>2</sup>
	RT	Tensile resilience	%
Bending	B	Bending stiffness	gf.cm <sup>2</sup> /cm
	2HB	Bending hysteresis	gf.cm/cm
	2HB 1.5	Bending hysteresis at k value 1.5	gf.cm/cm
Surface	MIU	Coefficient of friction	None
	MMD	Mean deviation of MIU	None
	SMD	Surface roughness	micron
Compression	LC	Linearity of stress-thickness curve	None
	WC	Compression energy	gf.cm/cm <sup>2</sup>
	RC	Compression resilience	%

## 2.4.2. The Fabric assurance by simple testing (FAST)

The FAST system was developed by the Commonwealth Scientific and Industrial Research Organisation (CSIRO) in Australia to measure the wool and wool blend fabric attributes and their impact on garment performance, handle and appearance. In other words, the generated data provide a language with which garment makers and fabric producers can communicate about cloth and garment properties and performance. Compared with KES-F, FAST is more simple, quicker to use and more suitable in the industrial area.

There is a special control chart provided to allocate and show the measurement output data. The normal shape of the connecting line between these data is snake-like. In the charts, there are shaded areas showing the limits of values' acceptance and rejection (where failure in cutting, laying-up, and garment construction and the sewing process is highly expected) (Bishop 1996). The system consists of three instruments and four tests. There is a template provided with the FAST system of 3 samples × 5 cm (width) × 13 cm (length).

### 2.4.2.1. FAST 1: Compression meter

This is used to measure the thickness at two loads 2 and 100 gf/cm<sup>2</sup>. The surface thickness is defined as the difference between the thickness at the two loads. The surface thickness could be a measure of fabric compressibility. The higher the surface thickness is, the higher the compressible the fabric is. This determines the stability of a fabric in the manufacturing processes.

### 2.4.2.2. FAST 2: Bending meter

This is the instrument used to measure the bending length. This instrument is based on the cantilever principle. In this apparatus, a light beam at an angle of 41.5° is presented instead of the two engraved black lines on the transparent sides on the Shirley stiffness tester and the mirror. This instrument is electronic and can measure the bending length and display it on the panel directly.

The following parameters are measured:

**Bending length  $BL$  (mm)** is read directly from the device display.

**Bending rigidity  $BR$  ( $\mu\text{Nm}$ )** The FAST system determines the bending rigidity from the measured cantilever bending length of the fabric using the principle described in BS: 3356 (1961), and fabric area density (CSIRO 1991)(see Equation 2.9).

$$BR = W \times BL^3 \times 9.81 \times 10^{-6} \quad 2.9$$

where:  $W$  = Fabric area density in  $\text{g/m}^2$

#### 2.4.2.3. FAST 3: Extension meter

Fabric extensibility is measured at three loads: 5, 20 and 100 gf/cm to obtain  $E_5$ ,  $E_{20}$  and  $E_{100}$  respectively. A sample is tested in its long direction. The extensibility in the bias direction is used to calculate the fabric shear rigidity.

**Shear rigidity ( $G$ )** (see Equation 2.10) (CSIRO 1991)

$$G \text{ (N/m)} = \frac{123}{EB5} \quad 2.10$$

where:  $EB5$  is the extension in the bias direction at 5 gf/cm.

#### Additional properties:

**Formability ( $F$ ) ( $\text{mm}^2$ ):** This is a measure of the extent to which a fabric is compressed in its own plane before it will buckle (see Equation 2.11) (Bishop 1996).

$$F = \frac{(E_{20} - E_5) \times BR}{14.7} \quad 2.11$$

#### 2.4.2.4. FAST 4: Dimensional stability test

This does not require a special apparatus. It measures the dimensional stability of the fabric. The method involves measurements of the fabric before and after a wet relaxation process. It can be completed in less than two hours and does not require a conditioned atmosphere.

### 2.5. Subjective evaluation

Basically, measurement of fabric mechanical properties are carried out subjectively. Subjective evaluation is based on the identification and assessment of fabric properties by people (subjects).

Clothing appearance is one of the most important aspects of clothing quality control. In the apparel industry, the assessment/evaluation of clothing appearance is vital for product development and quality assurance. However, the subjective assessment is completely assessor dependent, it is still the main applied method of evaluation rather than objective measurement systems because of their limitations. The visual assessment should be carried out on both the materials (components) of the cloth and the overall appearance (Slater 1997).



The major cloth characteristics (which are usually assessed) are the fabric surface smoothness, including the fabric wrinkle recovery, pilling propensity, smoothness after repeated laundering, seam appearance, crease retention and appearance retention of finished garments. Different methods and standards are available for assessing these characteristics. There are several factors affecting subjective assessment of fabric appearance (Slater 1997).

Reliability of subjective assessment output (results) is affected by several factors. Some of them are related to the assessors themselves (as an example: personality, state of mind or health) and others are due to factors which are out of the assessor's control (eg: the inappropriate evaluation scaling or grading). The quality of the assessors, the assessment scaling and finally the results analysis should be done carefully to ensure as accurate an assessment as possible (Slater 1997).

### **2.5.1. Training of assessors**

Training of assessors is important to cope with probable individual internal assessment scales while rating sample/s tested. This might enhance a subject to be a reassessor. Besides, employing subjects with good experience could produce consistent results.

### **2.5.2. Number of assessors**

It is recommended by the AATCC standards that three independent assessors are required in the subjective assessment. But generally, improving the results reliability could be made by increasing the number of assessors which gives the analyser an opportunity to cancel any individual difference or by calculating the 95% confidence interval of the average rating.

### **2.5.3. Assessment procedure**

Blind tests are recommended for tests dependent on tactile sensation in order to avoid biased or intentionally impaired/sabotaged assessment. But, this is impossible in the assessment of garment appearance which depends on visual assessment. So, an unspecified/undetermined evaluation purpose is desirable to avoid affecting the subject response for observation which would produce bias assessment.

### **2.5.4. Assessment scale and rating technique**

The subjective assessment scale or grading rates should be accurately established. The uniformity of intervals between grades should be born in mind during grading. It is preferable to check these using objective measurement methods.

There are different rating techniques in the subjective evaluation for instance:

- Yes/No evaluation (the simplest)
- Rank ordering (In this technique, each assessor is asked to rank (order) the tested samples from best to worse, and points are used to express the grades).
- Paired - comparison assessment (According to this system, a pair of samples are compared in every assessment. The better sample of both of them is giving a value of "1" and the other take "0". At the end of the test (evaluation), the samples are ranked according to the total sum of each specimen value (Fan 2004).

## **2.6. Summary**

Since the seminal work of Pierce in 1930, many researchers have worked to try to improve the objective measurement of fabrics. They have developed many different types of testing instruments and all have claimed various degrees of success in the measurement of various properties for different types of fabrics and for different fabric uses: formability, drape and handle. The most sophisticated and deeply research of the FOM systems is KES-F. However, though some South-East Asian countries, such as S. Korea and of course Japan, seem to continue to use this KES-F seems to have lost popularity in the west and particularly in the UK. This is probably due to high cost, high maintenance cost and being too complicated and time consuming. The FAST system is still popular and so too is the Shirley bending test and the drapemeter. This author's contention is that using flat fabric samples, not suspended as is used in a garment is unlikely to offer a test which will be accepted as a genuine challenge to subjective assessment.

## Chapter 3

### Drape measurement

#### 3.1 Introduction

Fabric drape is defined as the ability of a fabric (a circular specimen of known size) to deform when suspended under its own weight in specified conditions (British Standards Institution 2008; British Standards Institution 1998; British standards Institution 1973). It was defined by Chu *et al.* as “the property of textile materials which allows a fabric to orient itself into graceful folds or pleats when acted upon by force of gravity” (Chu, Cummings and Teixeira 1950). This property signifies fabrics from other materials such as paper which could have a similar bending length.

Fabric drape along with lustre, colour, texture, etc. defines fabric and garment appearance. It is a significant property as it does not only affect fabric and garment appearance but it also contributes to apparel fabric comfort along with other properties such as handle and performance factors (Zurek, Jankowiak and Frydrych 1985). Fabric drapeability is dependent on different variables such as fabric properties, object shape over which it is draped/hung and environmental conditions (Pandurangan 2003).

Drape is a quality which describes an important visual aspect of fabric properties and is normally evaluated by textile and apparel workers in design and manufacturing industry subjectively. Researchers have worked on interpreting drape quantitatively because of the limitations of individuals' assessments from lack of reproducibility to inconsistent agreement between assessors, etc. The significance and importance of analysing, understanding and measuring drape quantitatively is becoming increasingly realised by researchers and workers in the textile industry. To measure this quality, it is important to find a reliable, efficient and accurate method to reflect fabric real drape characteristics properly. Understanding drape using measured parameters can help to evaluate and ensure the appearance of the final clothes in real life, as well as improving computer simulation of fabrics. Quantifying this property determines to which extent and how a fabric is suitable to be made into a garment.

The importance of fabric and garment drape encouraged textile, apparel, and cloth modelling researchers to study various aspects of drape. Different studies have been carried out in different areas such as: studying different factors affecting drape, development of drapemeters (to make the measurement process: easy, accurate, less dependent on operator skills and to find a satisfactory presentation for drape) and proposing alternative fabric drape parameters (which was sometimes a result of drapemeter

development). Deriving equations to predict static and dynamic drape coefficients (the conventional drape parameters) and number of nodes theoretically using fabric mechanical properties was one of the fields of fabric drape investigations to make drape prediction and assessment easier and more quickly than experimental methods. This approach was extended to be applied in virtual 3D drape simulation. New techniques such as image analysis methods have been used in this area to carry out accurate and comprehensive studies. Moreover, dynamic drape behaviour (which is different from conventional static drape) by which dynamic drape with swinging motion can be measured which is similar to the human body motion were developed and studied. Different sewing parameters' effect on garment drape were considered in different investigations as apparel products must include seams.

Generally, there are two approaches to evaluate fabric drape, objectively by measuring either fabric physical and mechanical properties related to drape namely shear, bending, and weight or drape values on a drapemeter, and subjectively to relate it with the end-use product (Stylios, Powell and Cheng 2002; Stylios and Powell 2003).

### **3.2 Drapemeters**

Measurement of fabric drape started with Peirce in 1930 when he published his paper "The handle of cloth as a measurable quantity". In this paper he developed objective tests for measuring fabric bending length which was proposed as a measure of fabric draping quality (Peirce 1930).

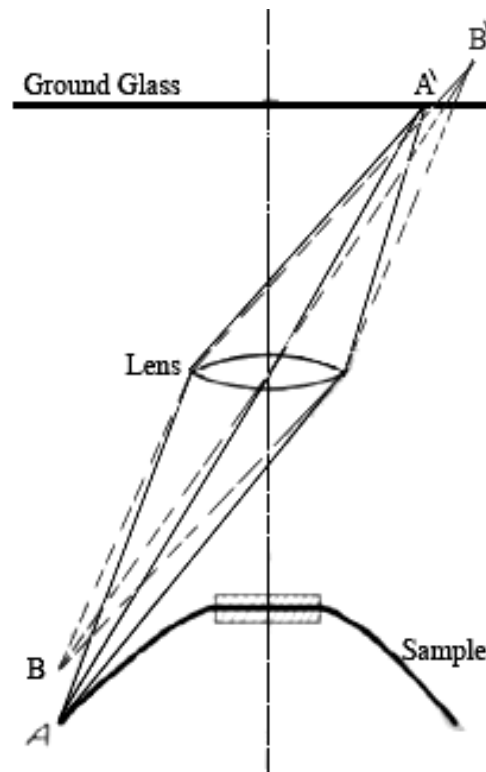
Bellinson set a drape tester at the M. I. T. Textile Research Laboratory. A fabric specimen was attached to the edge of a circular disc horizontally supported on a column. The drape length was the length of a sample measured from the top of the material to a point such that the length of the chord (distance between two ends of sample) is a given constant value. The higher the drape length was, the higher drapeability the fabric was. The radius of curvature of the sample and its variation along sample tested length was also used to compare between fabrics drapeability. It had a negative relation with fabric drapeability (Schwarz 1939; Winn and Schwarz 1939a).

Fabric drape was not clearly determined by those tests based on two-dimensional (mono planar bending) distortion of samples tested, as they measure bending properties rather than drape. A piece of paper and fabric could have similar bending properties while differing in their drape behaviour. These tests were not correlated with the subjective evaluation of drape. Consequently, a three-dimensional (multi planar bending) distortion apparatus was introduced by the Fabric Research Laboratories in Massachusetts. This tester measured drape quantitatively in a way which

shows its significant anisotropic properties. It was based on a principle similar to the one of showing and displaying yard goods in window shops at that time by draping them over a circular pedestal (Chu, Cummings and Teixeira 1950).

### 3.2.1 Static drape testers

In 1950, the original Fabric Research Laboratories' drapemeter was developed. In this optical apparatus, the sample tested was sandwiched between two circular plates mounted on a movable (up and down-wards) pedestal and should not touch the apparatus base. The optical system of this apparatus was used to cast the image of the sample draped on the ground glass - placed above the circular plates - which was traced by the operator (see Figure 3.1).



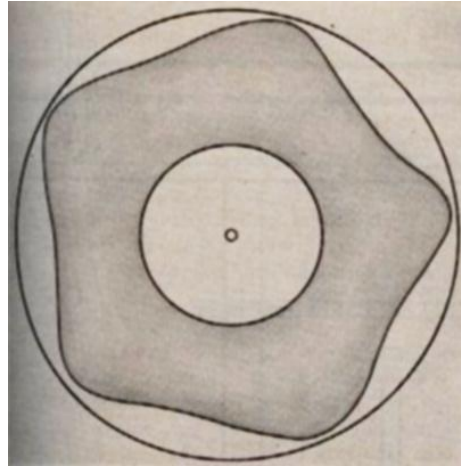
**Figure 3.1** Schematic diagram of F.R.L. optical drapemeter (Chu, Cummings and Teixeira 1950)

First "Drape coefficient"  $F$  was developed, as a parameter to analyse drape test data/image. It was defined as the fraction of the area of the annular ring between the flat fabric edge and the supporting disc edge covered by the projection of the draped sample (see Figure 3.2 and Equation 3.1).

$$F = \frac{\text{Area of the draped sample on the annular ring}}{\text{Area of the annular ring (between the two circles)}} \quad 3.1$$

This was analogous to the circularity coefficient which was used in textile microscopy. The higher the drape coefficient was, the less drapeable the

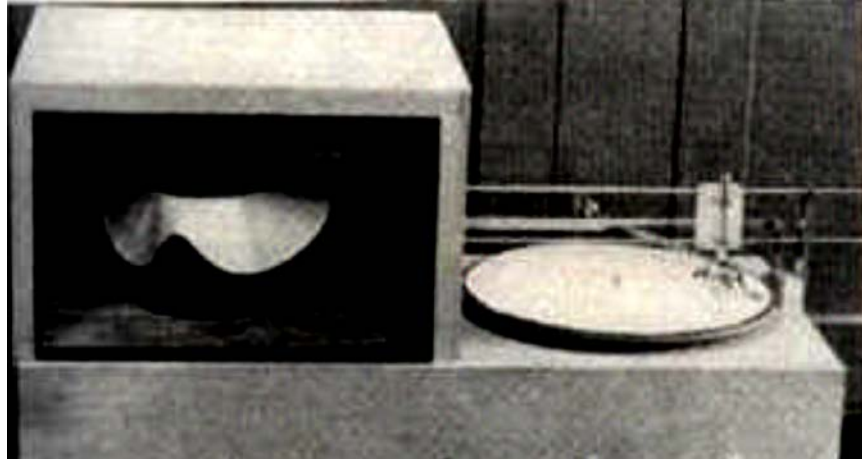
fabric was (Chu, Cummings and Teixeira 1950). It is noteworthy that this drape coefficient was used in most drape studies.



**Figure 3.2** Drape diagram (the dark grey area is the shadow of the draped sample on the annular ring) ((reproduced from(Chu, Cummings and Teixeira 1950))

A study of the accuracy of this apparatus found that there were errors which reached 8.5% in the image diameter and 17% in the measured area for 1 inch different elevation levels of fabric edge.(as fabric drape occurs with double curvature). Figure 3.1 shows the possibility of having different projections for points with equal distance from the central vertical axis of supporting disc with different elevation levels. This was one of the significant disadvantages of using this apparatus for measuring drape coefficient. The principle of the F. R. L. drapemeter of draping the sample tested on a circular disc was the basis of all/most of the further developed drapemeters. Improvements were carried out only to obtain more expressive and accurate data easily.

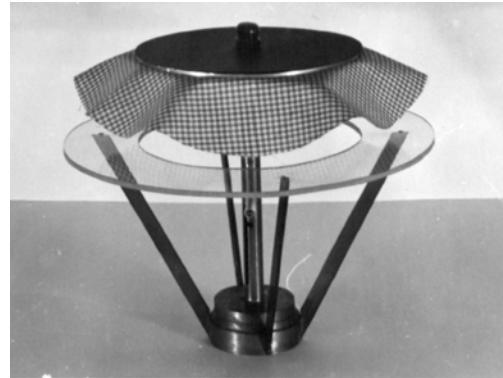
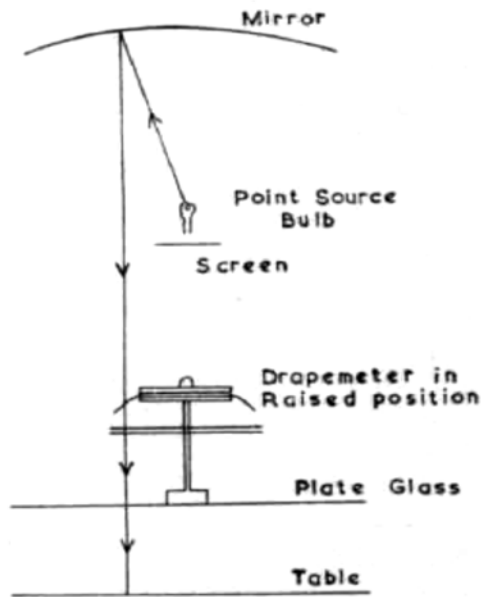
An improved F. R. L. drapemeter was developed to cope with the error in the original drapemeter (see Figure 3.3). In the improved tester, a sample (25 and 30 cm diameter samples were able to be measured) was draped on a circular disc (10 or 12.5 cm in diameter) which was one of two synchronised turntables and a standard circular chart was mounted on the other one. An optical system mechanically connected to a pen was used to scan the edge of the sample tested continuously and automatically in order to draw/trace the scanned edge on the chart. When one revolution was performed with the turntable carrying a sample, a complete drawn image of the draped sample was generated. A planimeter was used to obtain the drape coefficient (ratio of the draped sample's shadow area to the flat sample's area) (Chu, Cummings and Teixeira 1950).



**Figure 3.3** Improved F.R.L. drapemeter (reproduced from (Chu, Cummings and Teixeira 1950))

A further upgrade was carried out for the F. R. L. drapemeter by Cusick in 1962. He developed the optical system used in obtaining a draped sample projection (see Figure 3.4).

In this tester, the sample tested was also sandwiched between two horizontal sample discs with a diameter smaller than the samples'. The sample was mounted on the sample disc by means of a vertical pin placed centrally on the sample disc while the annular supporting disc was at the same level of the supporting disc. To carry out a test, the two discs with the sample were raised up in order not to touch the annular disc (see Figure 3.4 B). The apparatus was placed on a glass sheet as the sample's shadow was projected on a table underneath the apparatus by means of a light source and spherical mirror positioned above it which produced near parallel vertical light. The projected shadow was drawn on a sheet of paper placed on the table. The projection area was measured using a planimeter from which the drape coefficient DC was calculated as the percentage of the annular ring (between two edges of the sample disc and the flat sample) covered by the draped sample. Sample disc with 18 cm diameter and sample with 30 cm diameter were found the best standards and sensitive to a wide range of fabrics from limp to stiff which produced DCs from 30 to 98%. Drape coefficient value errors were high at high values.



(a)

(b)

**Figure 3.4** An F.R.L. drapemeter improved by Cusick in 1962, (a) Schematic diagram(b) Photograph(reproduced from (Cusick 1965; 1962))

Cusick in 1968 further improved the F. R. L. drapemeter in terms of obtaining more accurate drape coefficients with less tedious and less costly procedures. First, three different sample sizes (24, 30 and 36 cm diameters) were proposed as the smallest and largest samples were more sensitive for limp and stiff fabrics respectively. Second, an alternative less expensive optical system was proposed to replace the previous one. Divergent light from an ordinary light bulb with a mask of a 1 inch diameter hole placed centrally above the sample was proposed instead of the parallel light. He set equations for calculating DC values from practical and theoretical divergent light. According to the comparison between these two equations' results, he found that using the divergent light produce DC experimental values lower than the DC true/theoretical values. A graph was established and used in correction to the true values. He found highly correlated differences between DC diverging light values and each of the true (theoretical) DC values and DC parallel light values. Therefore he proposed that the correction of DC diverging light values to the theoretical true values would be reasonable. However, this correction graph did not produce DC values below 10% which were found to be impractical.

The third proposal was to use a cut and weigh method to measure the drape coefficient rather than using a planimeter, as using a planimeter needed double checking the measurement. The weight of a circular paper with a drawn vertically projected shadow was measured (W1) and another measurement was done after cutting along its perimeter (shadow) (W2) and

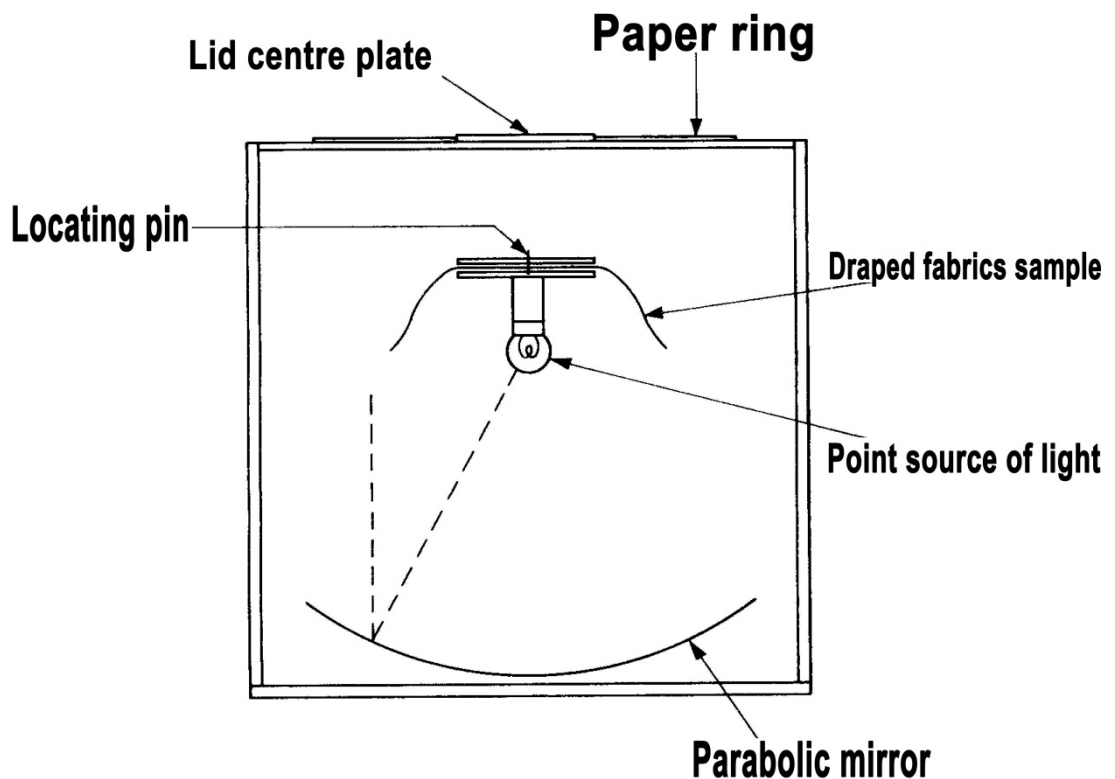


ratio  $W_2 : W_1$  was calculated. This drape coefficient correlated strongly with DCs measured using a planimeter employing diverging light (Cusick 1968).

In 2003, Behera and Pangadiya developed a drapemeter with an optical system based on the principle of Cusick's 1962 drapemeter but in a turned over position. This drapemeter was devised with a camera to capture images of tested fabrics. DC results were not significantly different from the conventionally measured DC (Behera and Pangadiya 2003).

Three British standards published by the British Standards Institution were found for measuring fabric drape coefficient. First: Method for the assessment of drape of fabrics (BS 5058:1973), second: Textiles - Test methods for nonwovens - Part 9: Determination of drape Coefficient (BS EN ISO 9073-9:1998), and third: Textiles - Test methods for nonwovens Part 9: Determination of drapability including drape coefficient (ISO9073-9:2008).

These standards were inspired by Cusick's work in 1962 and 1968. The optical system and apparatus were based on Cusick's 1962 but in an overturned position as the shadow was cast above the sample on a paper ring placed centrally above the supporting discs (see Figure 3.5). However, the cut and weigh method was inspired by Cusick 1968 (an alternative image analysis method was used in BS : ISO9073-9:2008).



**Figure 3.5** Drapemeter used in British Standards with codes: BS 5058:1973, BS EN ISO 9073-9:1998 and BS : ISO9073-9:2008

Fabric samples with correspondent paper rings with different diameters 24, 30 and 36 cm were used. Medium stiffness fabrics (DC between 30 - 85%) were measured using the medium size samples (30 cm), fabrics with stiffness higher than this range were measured using the largest sample size (36 cm) and ones with DC lower than that range were measured using the smallest sample size (24 cm) (British Standards Institution 1998; British standards Institution 1973; British Standards Institution 2008)

In the standard concerned with nonwovens drape, it was observed to record the sample tested behaviour when it tends to bend rather than making folds. If this is the case, it was suggested not to carry out the test.

### **3.2.2 Integrated drapemeters**

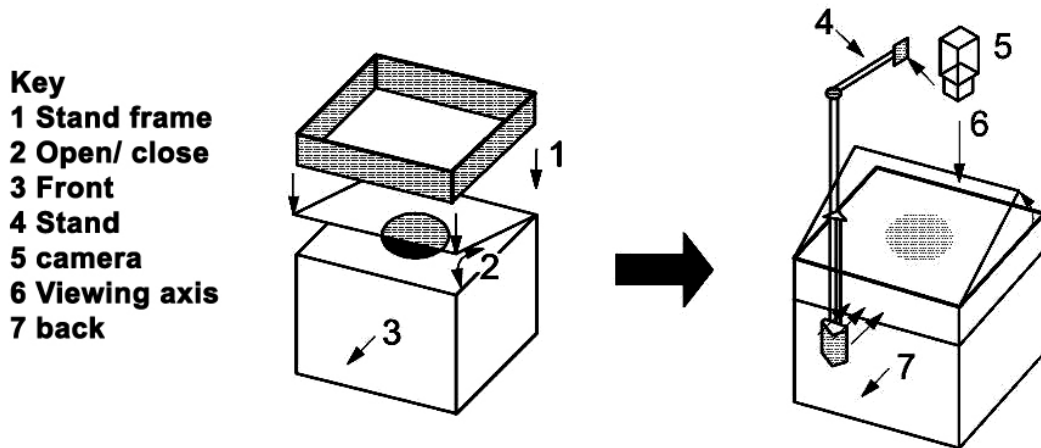
Limitations, inaccuracy, poor data and tedious measurement using the conventional drape testers encouraged drape researchers to adapt static traditional drapemeters to obtain more data with higher accuracy, repeatability and ease. Therefore, several adaptations were carried out for conventional drape testers, the most important effective integrations in studying drape were devising drapemeter with camera to capture images for the tested samples and/or rotatable supporting discs.

#### **3.2.2.1 Image analysis technique**

Researchers investigated the use of image processing technology in studying drape. In this method a digital camera is attached to a drape tester in order to capture images for draped samples (see Figure 3.6). By means of computer software detailed data such as drape shape parameters and statistical information including drape wave amplitude, wavelength and number of nodes were produced from these images. There are different advantages of studying fabric drapeability using an image analysis method as it is rapid and easy to carry out multiple measurements. Moreover, it enabled researchers to carry out studies such as fabric drape dependence on time from minutes to hours and investigating drape value instability and repeatability. Studying the relation between the rotation speed of the fabric tested and its drapeability was difficult without employing an image analysis method (Behera and Pattanayak 2008; Behera and Mishra 2006; Jeong 1998; Jeong and Phillips 1998; Kenkare and May-plumlee 2005; Tsai *et al.* 2009; Uçar *et al.* 2004).

Farajikhah *et al.* studied virtual reconstruction of draped fabric using shadow moiré topography employing front lighting and a linear grating. A captured image's centre and points located in the fringes were determined. The intensity and height of all pixels in the fringes were determined and plotted against the radius of the fabric edges. Using the radius (x), intensity(y) and height (Z) values calculated by given equations, 3D profiles of draped fabrics were generated (Farajikhah *et al.* 1986).

An image analysis technique was used in the British Standard: Textiles - Test methods for nonwovens, Part 9: Determination of drapeability including drape coefficient with code number BS EN ISO 9073-9:2008 (British Standards Institution 2008).



**Figure 3.6** Tools used in studying fabric's drape by image processing technology proposed by BS EN ISO 9073-9:2008

There were two methods of fabric draped image acquisition; namely projection capture and direct acquisition. Tsai *et al.* argued against the accuracy of the first method. As the draped fabric shadow was projected on a sheet above it as a single grey scale image, the projected light was not truly parallel which made the edge's points blurry; consequently the obtained contour was not highly accurate. Therefore they proposed an alternative method to enhance the image using the second method (directly acquired images). A backlight was placed underneath a fabric tested to enhance the contrast between the fabric and the background. The captured images were digitised and passed through a number of stages to calculate the drape coefficient. An image segmentation technique was used, the grey scale gradients in the image were calculated which was used to calculate the threshold value (if a pixel's gradient was higher than the defined threshold, it was defined as an edge point). This method exhibited higher speed in finding the image contour and better efficiency in obtaining images with better greyscale contrast which subsequently enhanced the application of image segmentation including calculations of gradient and threshold (Tsai *et al.* 2009).

### 3.2.2.2 Photovoltaic drapemeters

In 1988 Collier and his colleagues developed a photovoltaic drapemeter. A drape coefficient was measured by means of a voltmeter. This drapemeter was a box with the bottom surface made of photovoltaic cells, 2 supporting alternative plates (3 and 5 inch diameters) centrally placed on a column inside the box and a lid with a light source and a voltmeter (Collier, Paulins

and Collier 1989). The light source became horizontal and directly above the sample tested when the lid was closed to carry out a measurement and the draped sample blocked the light emitted by this source. The voltmeter attached to this drapemeter determined the amount of unblocked/sensed light by a sample tested by means of the photovoltaic cells.

Adapting the conventional drape testers with photovoltaic cells allowed measurement of the drape coefficient directly from the machine without any calculations. This instrument's output values (DC) ranged between 0 and 100%. The higher the DC value was, the more drapeable the fabric tested was, as more light was absorbed by the sensitive cells (Collier 1991).

The tester was calibrated when the fabric tested was changed in order to obviate the effect of fabric opacity on the measurement. The voltmeter was adjusted to 0% when a single layer of the tested sample completely covered the base and 100% when the cells at the bottom were exposed to the light directly without fabric barrier. They used the mean values of two specimens from each fabric with the face up and down. The increased blockage of light due to folded layers of a tested fabric was not considered as a measurement method's limitation, as high fabric drapeability was correlated positively with a high number of folded layers which increased the obstruction of light.

Fabric opacity effect on drape values was tested using a type of fabric in two colours (black and white). As it was important to be sure that the opacity of a tested fabric did not affect the amount of light absorbed by the photocells. A sample tested with any degree of opacity should have blocked the light completely and its drape values differ only due to its shadow area. They found that these two samples were not significantly different with respect to the drape values which indicated good accuracy of this digital photo drapemeter (Collier 1991).

### **3.2.2.3 Dynamic drapemeter**

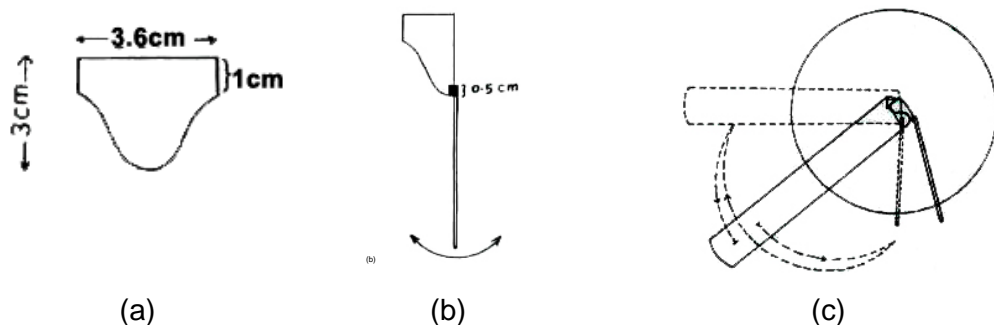
Drape researchers were concerned with obtaining drape values which correlated with real fabric drape and movement which encouraged them to start investigating dynamic drape rather than static drape in order to include the body motion aspect in their studies.

Ranganathan *et al.* used a dynamic apparatus to measure fabric drape behaviour in a style simulating the subjective assessment of average customers. Customers are used to assessing fabric drape by observing fabric draped vertically downwards and generated folds. The main aim of establishing this device was to tackle the big sample dimensions of conventional methods used to evaluate the drape behaviour, adopt an economical and efficient test for drape and to generate a test similar to the subjective assessment method which was the main reference assessment method since drape is considered as a quality rather than a quantity.

They were inspired by the shape and dimensions of the sample from bending behaviour and shape of real folds constructing fabric drape (see Figure 3.7 and Figure 3.8). Half of the sample shape was drawn by marking two vertical parallel straight lines (one of them was at the hidden part of the fold) and connecting them by a curve to make a taper off (nose) shape; this was doubled (folded) to obtain a sample. A needle was attached to the tested sample at the middle bottom of the taper off tip (nose shape). This needle was used to increase the effect of the fabric bending under its own weight and as an indicator for its response to the test. The sample was clamped in the apparatus and an arm was used to rotate the sample (needle) from  $0^\circ$  (original position) to  $45^\circ$  degrees twice at  $5^\circ$  intervals. The movement of both the arm and the response of the needle (sample) were recorded by means of a protractor to obtain a hysteresis diagram. The maximum value at  $45^\circ$  and the area of the hysteresis loop were used as parameters of drape behaviour. So, this objective method simulated subjective evaluation of drape, measured drape dynamically rather than statically as it is the case in the conventional drape test and plotted the results in simpler way than bending tests plots. The handle displacement was plotted against the needle reading rather than plotting the curvature against the couple in bending tests (Ranganathan *et al.* 1986).



**Figure 3.7** Contour of a specimen on a vertically draped fabric (Ranganathan *et al.* 1986).



**Figure 3.8** (a) sample dimensions, (b) Needle suspended on the specimen, (c) The sample mounted on the apparatus (reproduced from (Ranganathan *et al.* 1986)).

Dynamic drape behaviour was studied later using a system consisting of a drapemeter with a circular rotatable supporting disc and image processing devices (CCD camera and PC). The camera used should be able to capture

images for the tested sample at very short intervals (perhaps) at every 1/30<sup>th</sup> second. The range of the revolution speed changes according to the investigation.

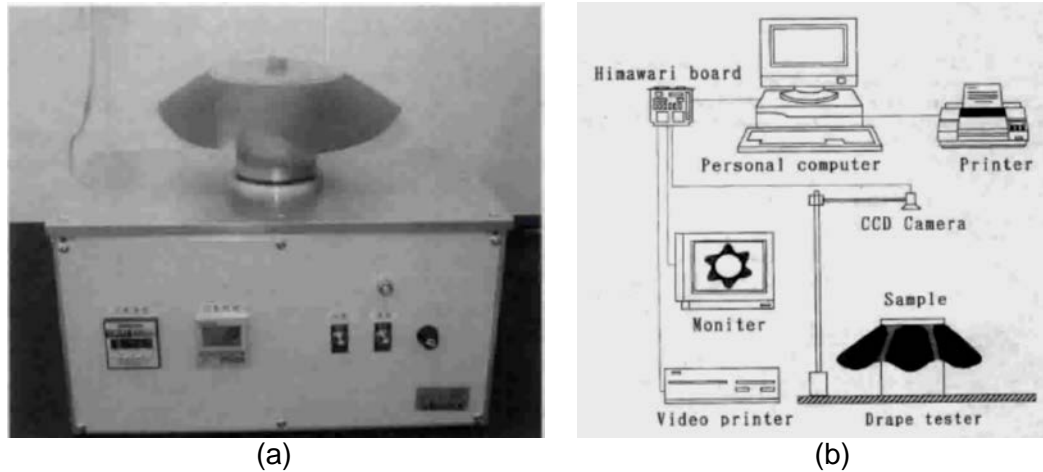
Stylios and Zhu indicated the importance of measuring dynamic drape of fabrics, as they found that fabrics had similar static drape behaviour, while differ in the dynamic drape behaviour. The dynamic drape presented the real fabric performance and would help textile, clothing and design workers in quantifying realistic drape behaviour of fabric. In the Research Centre of Excellence (University of Bradford) a true (static and dynamic measurement system) 3D drapemeter called The Marilyn Monroe meter (M<sup>3</sup>) was developed to work on the modelling of the dynamic drape of garments. This device consisted of a CCD Camera, a monitor to display the image, a cabinet with suitable light system, computer to process the captured images and a drapemeter with a rotatable supporting disc (43 r/min and 86 r/min) to investigate the static and dynamic drape of the tested fabric.

They proposed an efficient parameter correlated with subjective assessment of fabric drape called a feature vector  $V$  expressed as  $(\bar{p}_{max}, \bar{p}_{min}, S)$ , where  $\bar{p}_{max}$  was the average of the maximum fold's length (peak),  $\bar{p}_{min}$  is the average of the minimum fold's length (trough) and parameter  $S$  was an indication of how balanced or even the folds/nodes were (see Equation 3.2).

$$S = \sum_{i=1}^n \frac{(p_{max(i)} \times \bar{p}_{max})^2}{\bar{p}_{max}^2} \quad 3.2$$

where:  $p_{max(i)}$  was the maximum length of the  $i$  th fold/node, and  $\bar{p}_{max}$  was the average of the maximum length of the folds that make up the drape projection.  $S$  was equal to 0 when the folds were even and  $S$  was equal to 1 if the variation in the fold length was in the order of a fold length. Two more parameters  $\alpha_{max}$  and  $\alpha_{min}$  were proposed, these were the slopes of lines connecting overhang points on the circular disc and the free ends at maximum and minimum node length respectively. They classified the measured fabrics subjectively into 4 classes used in the clothing industry according to the feature vector results (Stylios and Zhu 1997).

Matsudaira and his colleagues proposed studying the dynamic drape behaviour as an alternative approach for investigating fabric drape and published a series of papers focused on this subject. The device and system shown in Figure 3.9 (a) and (b) respectively were built to carry out this series of studies. The tester consisted of a circular supporting disc with the same diameter as the Japanese industrial standard drape tester (12.7 cm) and capable of rotating with speed ranged between 0 - 240 rpm. An image analysis system was employed to capture and analyse the images of the tested draped samples (Matsudaira and Yang 2000).



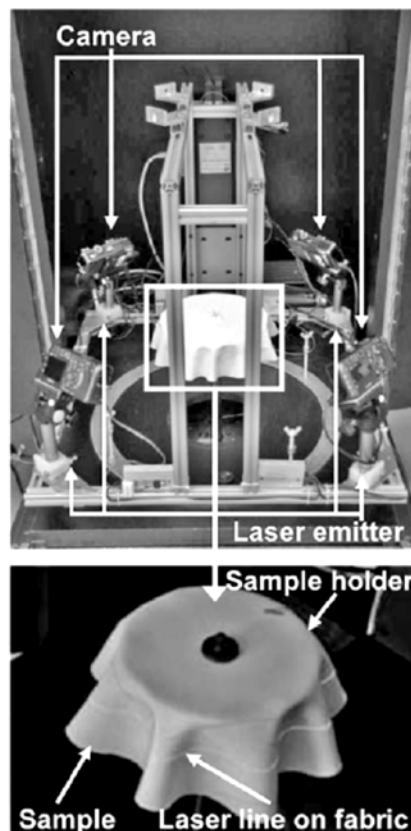
**Figure 3.9** (a) Dynamic drape tester, (b) System of measuring dynamic drape using an image analysis method (reproduced from (Matsudaira and Yang 2000))

Dynamic drape parameters with rotation speed ranging from 0 to 240 rpm with the ability to reverse the rotation direction at an arbitrary angle were developed. The first property was the revolving drape-increase coefficient ( $DC_r$ ) which presented the overhanging fabric's degree of spreading with increasing rotational speed (presented by the slope of the curve of the relation between revolutions and drape coefficients at the stage between 50 - 130 rpm). High  $DC_r$  value indicated a fabric's ability to change easily with revolutions. The drape coefficient at 200 rpm was selected for the dynamic drape coefficient ( $DC_{200}$ ) which presented fabric saturated spreading at rapid speed, as the change of the drape coefficient became lower than the previous stage. It was observed that the drape coefficient did not reach a maximum even at the maximum revolution speed (240 rpm). It was noted that the drape coefficient at the first stage (below 40 rpm) showed similar values to the static conventional drape coefficient  $DC_s$  (Matsudaira and Yang 2000).

Lin *et al.* studied the dynamic drapeability of four natural fabrics at a wider range of revolution speeds (0 - 450)rpm for a sample disc with 18 cm diameter. Images were captured for fabrics tested at 25 rpm regular intervals. The resultant curve presented the relation between drape coefficient and revolution speed and showed four stages of dynamic drape behaviour by the tangent partition method. These were initial growth, fast growth, slow growth and the last stage was the stable dynamic drape coefficient. Plots of experimental drape coefficients showed that the order of the fabrics was dependant on the revolution speed at which the DC was measured. Their order was changed three times in the fast growth stage and returned to the initial growth order and became stable at the two periods following the fast growth (slow growth and dynamic stable). The analysis of the results showed that a nonlinear logistic function was appropriate to

present the drape coefficient curves throughout the static state and the dynamic stable region (Lin, Wang and Shyr 2008).

The Sylvie 3D drape tester based on 3D scanning of the fabric tested was developed at the Budapest University of Technology and Economics (see Figure.3.10). Software was developed to reconstruct a virtual image for the scanned fabric from which ordinary drape parameters were calculated. Annular supporting discs with 21, 24 and 27 cm were used to exert dynamic impact (similar to real dynamic effect of a garment) on the fabric tested, which was already supported by a circular disc (18 cm diameter). Using this tester they studied fabric drapeability in terms of effect of composite yarns twisting direction and exerting dynamic effect on fabric tested (Al-Gaadi, Göktepe and Halász 2011).



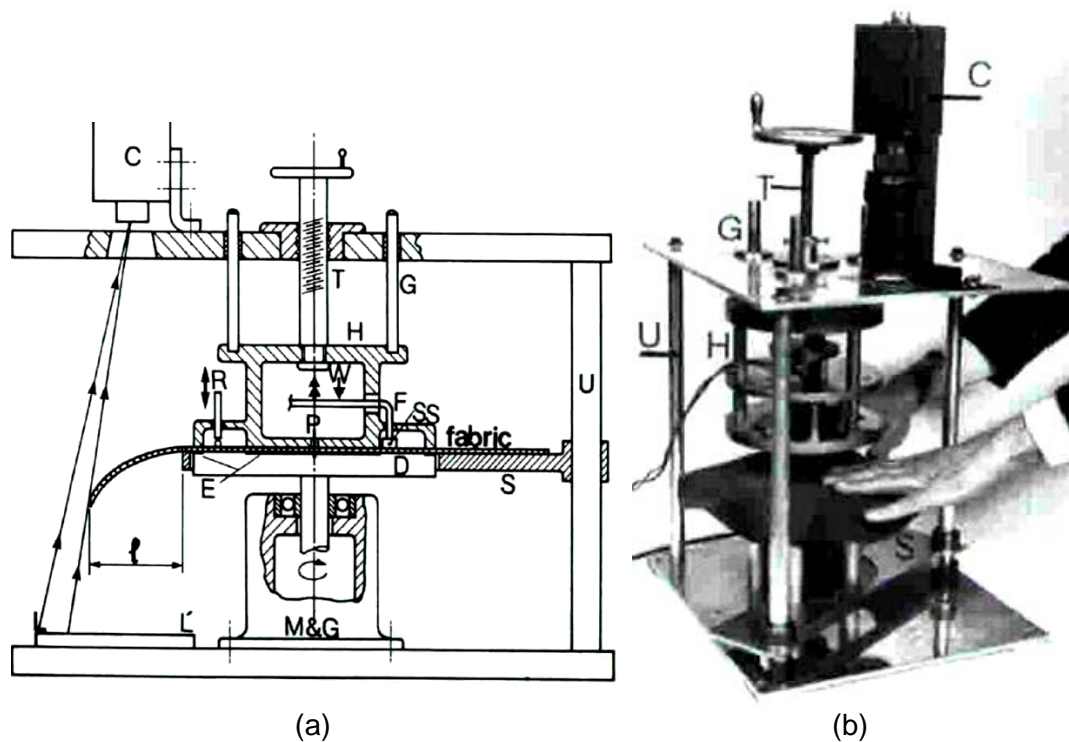
**Figure.3.10** Sylvie 3D Drape tester (reproduced from (Al-Gaadi, Göktepe and Halász 2011))

#### 3.2.2.4 Alternative drapemeters

Hearle and Amirbayat developed a multipurpose fabric tester (see Figure 3.11). This tester was capable of measuring different physical and mechanical fabric properties such as surface properties, drape coefficient, and bending stiffness by means of simple adjustments to its functional parts. A tested sample (24, 30 or 36 cm diameters) was located by pin P centred on a platform which included a supporting disc D with 18 cm diameter. Plate S was lowered to drape the sample freely as it was in the conventional



drapemeter. A sample tested rotated at 1 rpm by means of a supporting disc, 600 readings at regular intervals were recorded for space/distance between the pin and the sample edge PL by camera C fixed above the rotating disc. The readings were used to obtain the projected area of the draped sample from which the drape coefficient was calculated. This device's microprocessor could analyse the resultant values statistically except the drape values (which is an overall property). The absence of the physical contact between the measured sample and the device parts during bending stiffness and drape coefficient tests maintained high measurement reproducibility. Results obtained from this tester showed strong correlation with the conventional method (Hearle and Amirbayat 1988).

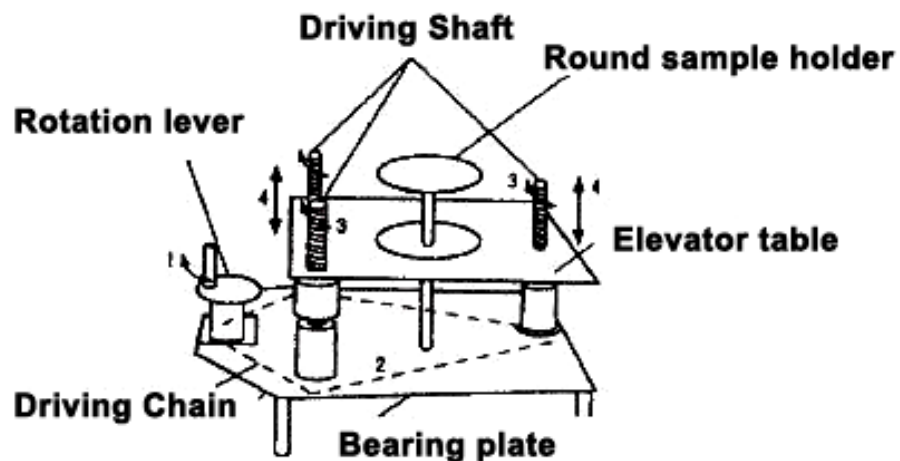


**Figure 3.11** (a) Schematic diagram and (b) photo of Hearle and Amirbayat 1988 multipurpose tester of drapeability (reproduced from (Hearle and Amirbayat 1988))

According to Mizutani *et al.*, the conventional Japanese drape test (JIS L-1096 1999) included a drape apparatus based on the Fabric Research Laboratories drapemeter features. However, it was adapted to be a closed drapemeter with a 12.7 cm diameter rotatable sample disc. The measurable sample dimension was 25.4 cm in diameter. The tested sample rotated after mounting for 10 seconds at 120 rpm rotation speed to hang down under its own weight. A photoelectric tracing method was used to record the vertically projected shadow of a draped sample.

Mizutani *et al.* developed a drape elevator to investigate the effect of the initial state of the measured sample on its drape, in addition to the stages of

drape generation (see Figure 3.12). It is similar to the conventional Japanese drape tester but they replaced the rotatable sample disc with a fixed one and attached an elevator table to it, which was capable of moving downwards and upwards by means of a lever. A test started with both table and disc at the same level and then the operator lowered the table until the tested sample became completely free and hung under its own weight (6.4 cm distance down the sample disc was enough to allow any tested sample to hang down). A digital camera was set above the drapemeter to record and capture the stages of drape generation (Mizutani, Amano and Sakaguchi 2005).

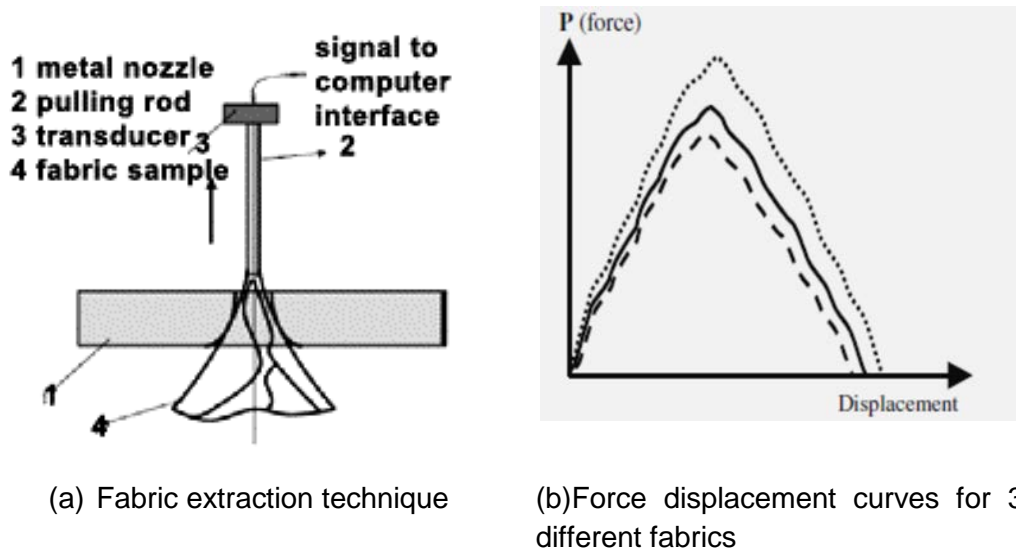


**Figure 3.12** Drape elevator of Mizutani et al. (Mizutani, Amano and Sakaguchi 2005)

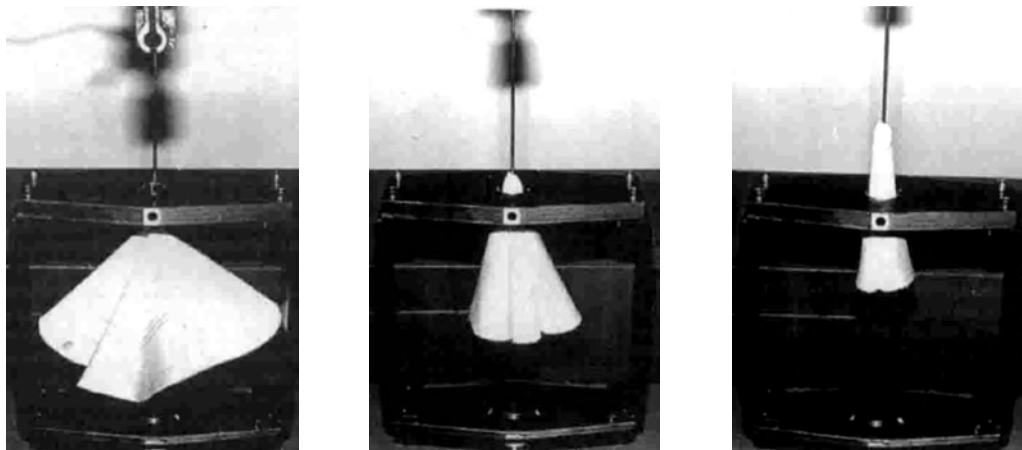
They used their drapemeter to study the stages of drape formation. They determined that there were three stages of drape formation. These were node appearance (early stage), drape growing from the nodes (next stage), stabilised drape (final stage). They proposed that correlation between the drape coefficient and drape formation (shape) during its generation would provide useful data for computer drape simulation to represent reliable virtual drape. The early stage has the most important role to determine the drape characteristics, however the final stage was responsible for the completion of this determination. The drape formation resulted from mutual relationships between the sample weight and bending properties, and the friction between the sample and the elevator table surface (in the drape elevator of Mizutani *et al.*)(Mizutani, Amano and Sakaguchi 2005).

Textile researchers were inspired by consumers' (ladies) evaluation for scarf fabrics as they used to pull a scarf through a ring to assess its behaviour. In this test, the fabric is subjected to multi deforming stresses: tensile, shear and bending. This test produced a load- displacement extraction curve and the peak or slope at certain points were used to compare between fabrics. Researchers correlated fabric drapeability with its hand property measured by their developed fabric extraction test apparatus and programme (see

Figure 3.13 and Figure.3.14) (Grover, Sultan and Spivak 1993; Kim and Slaten 1999).



**Figure 3.13** Pan's system for measuring fabric hand (Pan 2007)



(a) Handle force device on tensile tester      (b) Initial portion of fabric specimen being withdrawn through the ring      (c) Later portion of fabric specimen being withdrawn through the ring

**Figure.3.14** Stages of extraction tests used by (reproduced from (Grover et al. 1993))

Cassidy in 2002 proposed an alternative method for measuring fabric drape using an Instron tester. In this method a circular sample is supported between two discs, one of them is movable vertically by means of the Instron cross head and the other disc holds the sample tested and is considered the raised solid platform. A load-displacement graph is used to measure the drape behaviour of measured fabric. The area under load - displacement curve of fabric measured was compared with the areas under load displacement curves calculated for theoretical perfect flexible and perfect stiff fabrics. This method had significant correlation with the traditional DC ( $r = 0.83, p < 0.01$ ) (Cassidy 2002).

### **3.3 Drape parameters**

Since, fabric drape is a quality rather than a quantity. Textile workers in apparel design and making depend on subjective assessment to evaluate it. Researchers concerned with drape have been long working on developing objective drape parameters due to error in subjective evaluation. They aimed to find parameters which could be reliable and representative of fabric drape. These parameters were highly related to the drapemeter used and its features (parts integrated to it). Conventionally, a drape coefficient has been used to determine fabric drapability. While integrating, devising and/or adjusting the conventional drapemeters allowed drape researchers to develop alternative parameters.

#### **3.3.1 Drape coefficients (DC)**

Generally, drape coefficient was used as the traditional fabric drape parameter. It is expressed as the ratio of a draped fabric's shadow when it is partially supported to its undeformed flat state in terms of area. This ratio was calculated using weight or area units measured by a planimeter (Chu, Cummings and Teixeira 1950), weight (Cusick 1968), image processing software (Vangheluwe and Kiekens 1993) or photosensitive cells (Collier 1991). It basically ranges between 0 – 100%.

Alternative drape coefficients were developed and considered as adjusted coefficients from the original drape coefficient of Chu *et al.* 1950.

Vangheluwe and Kiekens in 1993 were the first researchers to use the number of pixels to calculate a drape coefficient using image processing software. Images were captured for fabric tested, transferred to computer, its dimensions were calibrated and the shadow was traced. DC was calculated as the ratio of the area of the annular paper ring covered by a draped sample shadow to the annular paper area (both of them expressed in the number of pixels (Vangheluwe and Kiekens 1993). This method was used by further researchers (Ruckman, CHENG and Murray 1998).

In 1998, Jeong argued against the accuracy of Vangheluwe and Kiekens's method, as different drape coefficients resulted for similar shapes with different directions relative to the camera. The difference increased as the shape become bigger or more uneven. He proposed an alternative approach as the captured image was digitised, thresholded and processed by the closing operation. The image analysis system detected the edges of the circular plate and shadow of the draped fabric. The drape coefficient was calculated using these boundaries (see Equation 3.3):

$$DC = \frac{\text{Fabric's shadow area} - \text{support disc's area}}{\text{the area of the region outside the supporting plate} - \text{support disc's area}} \times 100 \quad 3.3$$

This method showed good correlation with the cut and weigh (conventional) method and high repeatability (Jeong 1998).

Frydrych *et al.* used the Polish standard for measuring the fabric drape coefficient (K). It was defined as the ratio of the area between two edges of the original and the draped sample's shadow to the area of its flat unsupported part (0.027 m<sup>2</sup>). It was calculated according to Equation 3.4.

$$K = \frac{\pi r^2 - s}{\pi(r^2 - r_1^2)} \times 100 \quad 3.4$$

where, S is the sample's shadow area (m<sup>2</sup>), r<sub>1</sub> is the radius of the disc supporting the sample (0.035 m), r is the sample's radius (0.1 m). This ratio was considered to be more comprehensive than the conventional DC as it correlated directly with fabric drapeability. It increased with the fabric drapeability which was the opposite of the conventional drape coefficient which decreased with high drapeability fabric (Frydrych, Dziworska and Matusiak 2003).

Gider developed an alternative approach for measuring drape coefficient. The drawn shadow of a draped sample was scanned using a 2D digital scanner after reducing its scale to 70% on a photocopying machine to fit on the scanner pad. After that, the image was exported to Photoshop software to calculate the drape coefficient by counting the number of pixels which occupied the area of the projected shadow and divided it by the flat specimen area expressed in number of pixels (Gider 2004).

Kenkare and Plumlee modified the digital calculation of drape coefficient and applied Equation 3.5 (Kenkare and May-plumlee 2005) .

$$DC = \frac{\text{Total shadow pixels} \div \text{pixels/cm}^2 - \text{area of supporting Disc (cm}^2\text{)}}{\text{Area of the specimen (cm}^2\text{)} - \text{area of supporting Disc (cm}^2\text{)}} \quad 3.5$$

### 3.3.2 Static drape profile/image analysis

Drape researchers aimed to obtain more representative drape parameters. Further analysis of the draped fabric shadow image was their approach to generate their proposed parameters.

In 1960, Chu *et al.* indicated that one of the most important aspects of understanding the drape mechanism was studying fabric drape geometry; i.e. the draped sample shadow configuration. The drape diagram (a projected two-dimensional simplification of the three-dimensional draped sample) contains three items of significance: the area, the number of nodes and the shape of the nodes. The area is the basis of the drape coefficient F and the nodes or pleats formed in a draped sample by virtue of the buckling

of the material. It was observed that the number of nodes within any particular sample correlated directly with DC for a given test condition. They induced that drape profile/geometry could be easily predicted from the drape coefficient (Chu, Platt and Hamburger 1960).

Hu and Chung determined and compared the drape behaviour of seamed woven fabrics in terms of drape coefficient, node analysis and drape profile. The variability of the number of nodes was used as an indicator of fabric drape stability. Regularity of node arrangement, their orientation, location and highest and lowest node length were proposed as drape parameters (Hu and Chung 1998).

Rodel *et al.* characterised the drape configuration by area, form and amplitude of the folds, the number of folds and their position with regard to warp and weft directions (Rodel *et al.* 1998).

Jeong proposed "Drape distance ratio" as an alternative measure of drape. It was based on distance whereas the drape coefficient is based on area. It increased as a fabric become more flexible and was calculated using Equation 3.6.

$$R_d = \frac{r_f - r_{ad}}{r_f - r_d} \times 100 \quad 3.6$$

where  $R_d$  was the drape distance ratio,  $r_f$  was the radius of the undraped sample,  $r_{ad}$  was the average radius of draped sample's profile,  $r_d$  was the radius of the supporting disk. He induced from this study that the drape coefficient was not a sufficient parameter in establishing an objective index for drapeability as garment drape was affected by different factors which should be involved in characterising fabric drape. There were geometrical factors affecting drape such as the number of nodes and the curvature of the draped fabric. It was preferred to use the node distribution to characterise the drape profile (Jeong 1998).

Four virtual parameters were used by Stylios and Wan to define the drapeability of textile materials as follows: virtual drape coefficient, drape fold number, fold variation, and fold depth (Stylios and Wan 1999).

Robson and Long used imaging techniques to analyse fabric drape profile. Fabric drape profile was transformed from  $r - \theta$  polar coordinates into  $x - y$  coordinates. The nodal configuration was characterised by automatic measurement of: number of nodes NN, mean node severity MNS (node height/node width) (similar to Chu *et al.*'s 1960 "shape factor"), the variability of node severity VNS and circularity of the drape profile. Strong correlation was found between DC and circularity CIRC and Mean node severity. Node severity was found to be strongly and inversely related to DC. The DC was not found strongly correlated with the number of nodes and variation in node

severity parameters which were poorly correlated between themselves. Measurement of these three parameters (DC, NN and VNS) in combination provided an excellent description of fabric drape profile, with potential application in a number of garment design and assembly areas. A DC value essentially provides information concerning the overall degree of drape, whereas the NN and VNS values gave more detailed information concerning the nature of the drape pattern (Robson and Long 2000).

Behera and Pangadiya proposed using a combination of drape parameters namely: Drape coefficient, average, maximum and minimum radius, drape distance ratio (*DDR*) (see Equation 3.7), amplitude to average radius ratio (*ARR*)  $\left[\frac{A}{\bar{r}}\right]$ , number of nodes and fold depth index (*FDI*) (see Equation 3.8).

$$DDR = \frac{r_2 - r_s}{r_2 - r_1} \quad 3.7$$

$$FDI = \frac{r_{max} - r_{min}}{r_2 - r_1} \quad 3.8$$

where  $r_1$ ,  $r_2$ ,  $r_s$ ,  $\bar{r}$ , were the radii of the supporting disc, flat sample, draped sample, average of draped sample and  $A$  was the amplitude  $[r_{max} - r_{min}/2]$  (Behera and Pangadiya 2003).

Ucar *et al.* investigated the drape behaviour of seamed knitted fabrics using image analysis in terms of drape coefficient, drape profile and node analysis (Uçar et al. 2004).

Jevšnik and Geršak investigated using a finite element method for fused panel simulation. Experimental drape parameters including drape coefficient, number of folds, minimum and maximum amplitude and the distance between folds, fold distribution  $G_p$  (see Equation 3.9) were used.

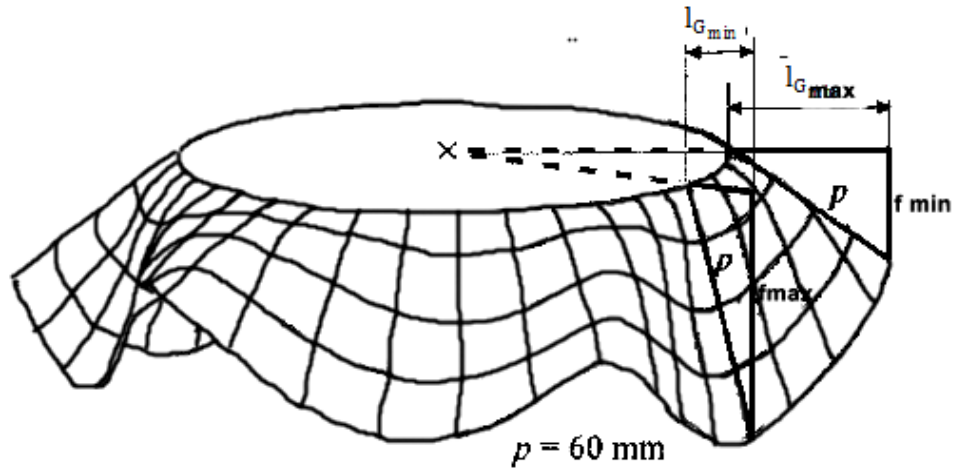
$$G_p = \sum_{i=1}^n \frac{(l_{G_{max}(i)} l_{G_{max}})^2}{l_{G_{max}}^2} \quad 3.9$$

New parameters were proposed (see Figure 3.15); namely Maximum hang of fabric sample  $f_{max}$  (Equation 3.10), Minimum hang of fabric sample  $f_{min}$  (Equation 3.11) and the fold's depth  $d_G$ , where  $l_{G_{max}}$  was the maximum depth of the fold and  $l_{G_{min}}$  (Equation 3.12) was the minimum depth of the fold and  $p$  was the perimeter/length of the circular sample (60 mm) draped over the pedestal. There was similarity between virtual and experimental fabrics. Moreover, rheological parameters: Young's and shear modulus in warp and weft directions and Poisson's ratio were used (Jevšnik and Geršak 2004).

$$f_{\max} = \sqrt{p^2 - (l_{G_{\min}})^2} \quad 3.10$$

$$f_{\min} = \sqrt{p^2 - (l_{G_{\max}})^2} \quad 3.11$$

$$d_G = l_{G_{\max}} - l_{G_{\min}} \quad 3.12$$



**Figure 3.15** Jevšnik and Geršak drape parameters (Jevšnik and Geršak 2004)

Mizutani *et al.* proposed an alternative drape shape parameter (R) presented complexity degree of tested sample drapeability with positive correlation between them. This parameter characterised the drape behaviour of fabric clearer than the drape coefficient only. It was calculated using Equation 3.13.

$$R = \frac{\sqrt{(r - r_0)^2}}{r_0 - r_s} \quad 3.13$$

where:  $(r - r_0)$  was calculated along the whole contour of the drape projection,  $r$ ,  $r_0$  and  $r_s$  were radial coordinates of the drape projection, the radius of a circle with an area equal to that of the drape projection, and the radius of the sample holder (Mizutani, Amano and Sakaguchi 2005).

Kenkare and May-plumlee used the number and dimensions of nodes as alternative parameters to drape coefficient to quantify drape (Kenkare and May-plumlee 2005).

Jevsnik and Zunic-Lojen proposed using the maximum amplitude of folds  $l_{G_{\max}}$ , minimum amplitude of folds  $l_{G_{\min}}$  and the angle between two neighbouring peaks of the folds  $\alpha_i$  to measure drape (Jevšnik and Žunič-Lojen 2007).

Ngoc and Anh measured fabric drape coefficient and drape profile using a Cusick drapemeter. To compare between measured fabrics, the displacement of the folds were measured on the original drape profile at



32 different angles at regular intervals to convert them into x (angle), y (fold's displacement) coordinates (Ngoc and Anh 2008).

Behera and Pattanayak used MATLAB software to write a programme in order to calculate a combination of parameters including: drape coefficient, drape distance ratio, amplitude to average radius ratio, number of folds and fold depth index. This measurement was based on an Indian standard (Behera and Pattanayak 2008).

British Standard for determination of drapeability of nonwovens stated using image processing technology to analyse fabric drape. Contour of two-dimensional monochrome images of draped shadows were firstly transformed into polar ( $\theta$ ,  $r$ ) coordinates and then transformed into an x, y chart. X-axis presented the angle in degrees ( $\theta$ ) from  $0^\circ$  to  $360^\circ$ , from the baseline passing through the centre of the circle, and the Y-axis presented the amplitude ( $r$ ) in centimetres. The shape parameters of a two-dimensional geometric drape model were defined as the number of nodes (waves or folds), the positions of nodes, wavelength and amplitude data. Various statistical information were obtained using image processing technology and frequency analysis as well as the traditional drape coefficient (British Standards Institution 2008).

Shyr *et al.* transferred fabric drape image to fabric drape profile using Matlab® software. The pixels making up the boundary of the silhouette of a drape profile were converted into drape profile coordinates ( $x_m$ ,  $y_m$ ). These coordinates were then substituted into the drape profile ratio formula, which converted the drape profile coordinates into the corresponding drape profile locations ( $p_m$ ,  $v_m$ ) in clockwise direction starting at  $180^\circ$ . Calculation of the fabric drape profile ratio yielded a drape waveform diagram. The drape profile ratio  $DPR$  was calculated as the ratio between the distance from a small disk's edge to the margin of the draped profile and the difference between the radii of the large and the small disks using Equation 3.14.

$$DPR = \frac{r - r_0}{r_f - r_0} \quad 3.14$$

where  $r$  was the distance from the drape profile's edge to the origin,  $r_0$  was the radius of the small disk (9 cm) of the drapemeter,  $r_f$  was the radius of the circular fabric profile (15 cm) (Shyr, Wang and Lin 2009).

Al-Gaadi *et al.* studied fabric drapeability using drape parameters including: drape coefficient (DC), drape unevenness (DU), number of waves/nodes, and maximum, minimum, deviation of amplitudes. Drape coefficient (DC) was calculated using Equation 3.15.

$$DC = \frac{A_r - \pi R_1^2}{\pi R_2^2 - \pi R_1^2} \times 100 \quad 3.15$$

where  $A_r$  was the area of the draped fabric's projection,  $R_1$  was the radius of the sample disc and  $R_2$  was the radius of the flat fabric. The drape unevenness (DU) was calculated using Equation 3.16.

$$DU = \frac{\sqrt{\frac{\sum_{i=1}^n (WL_i - \overline{WL})^2}{n-1}}}{\overline{WL}}, \quad 3.16$$

as follows: where  $WL_i$  was the central angle between two adjacent maximum amplitudes (i.e. the wave length of single waves),  $\overline{WL}$  was the average central angle on one wave (i.e. average wave length,  $\overline{WL} = 360/n$ ) and  $n$  was the number of waves. DU had a reverse/negative relation with drape profile evenness (Al-Gaadi, Göktepe and Halász 2011).

### 3.3.3 Fourier analysis

Fischer *et al.* developed a program to use Fourier analysis to interpret drape profile geometry. They proposed using the resultant Fourier coefficients as alternative drape values to obtain information about the drape profile in terms of wave amplitude, number of waves and the curvature of the waves (Fischer *et al.* 1999).

Behera and Pangadiya studied the correlation between drape coefficients measured using different image analysis techniques. Pixel counting (number of pixels occupying a draped fabric shadow), boundary approximation (area of the shadow calculated using its edge's points at 10 or 1 degree(s) interval 36 or 360 points respectively), Fourier approximation and conventional methods were compared. The first two techniques showed significant difference. The pixel count method and the conventional method showed good correlation and agreement. The image processing methods showed lower variation than the conventional method. The pixel count had higher variation than boundary approximation and Fourier series methods (Behera and Pangadiya 2003).

Sharma *et al.* in 2005 studied fabric drape using Fourier analysis software. The following drape values: Drape coefficient, number of nodes, minimum, maximum and average radius, and average amplitude were obtained from resultant Fourier coefficients (Sharma *et al.* 2005)

Kokas-Palicska *et al.* proposed using a spectral function (*x wavelength, y wave amplitude*) resulting from a Fourier transform for drape projection as an easy and fast approach/method for drape comparison. This approach was tested on fabrics treated with a soft finish and showed efficiently the effect of that treatment (Kokas-Palicska, Szücs and Borka 2008).

British Standard (BS EN ISO 9073-9:2008) proposed using Fourier analysis in studying drape. Fourier transformation was conducted for the Cartesian plot which presents transformation of the original polar plot of the drape profile. An ideal wave was reconstructed using the dominant wave resulting from a Fourier transform. Fitness factors was proposed to verify the fit of the Fourier transformation and to determine the dominant wave, expressed as percentages. These were ratios of the following (Equations 3.17 and 3.18).

$$\text{Fourier transform/original} = \frac{B_f}{B_0} \times 100 \quad 3.17$$

$$\text{Dominant/original} = \frac{B_d}{B_0} \times 100 \quad 3.18$$

where:  $B_0$  was area of the original captured draped image,  $B_f$  was the  $B_0$  Fourier transformed shape,  $B_d$  was the ideal shape recomposed from a determined dominant wave (British Standards Institution 2008).

### 3.3.4 Standard drape values

Measurement of a parameter or property should be carried out several times for statistical requirements. It is necessary to measure drape values several times to obtain reliable and dependable results. But how many tests (drape values) are required and what number of nodes represent the drape value?. Jeong proposed what was called the standard drape values. These were the values with the most frequent number of nodes obtained, since the variation of the drape values within the same node was not large/high. It was found that the deviation of drape values for each number of nodes was smaller than the variance of the whole measurements (entire node set), this may be due to hysteresis of fabric shear and bending. This indicated that the number of nodes affected the drape values. Fabrics with high sensitivity to the tests should be measured more times than those with lower variance. At this point the importance of the image analysis method was revealed as this investigation is so tedious when carried out by the conventional cut and weigh method (Jeong 1998).

### 3.3.5 Measurement of number of nodes objectively

Since subjective node numbers were determined by visual judgment of drape image, different results could be obtained by different fabric personnel. The increased inconsistency of the subjective assessment of nodes number encouraged Shyr *et al.* to develop an objective approach for this measurement/test.

Fabric drape images were converted into drape profiles with (x, y) coordinates for all boundary points which were illustrated in wave form to calculate (work out) the threshold node (TN) value. The objective node numbers were determined by the threshold node value resulting from

Equation 3.19, the distance between peak and trough  $(P - T) > TN$ , a node was defined as in Equation 3.19.

$$TN = \bar{x}_{(p-T)} - z_{(1-\alpha)} \times s_{(p-T)} \quad 3.19$$

where: TN was the threshold of the node,  $\bar{x}_{(p-T)}$  was the sample mean of the difference between peak and trough,  $z_{(1-\alpha)}$  was the  $(1 - \alpha)$  percentile of a standard normal variable, and  $s_{(p-T)}$  was the sample standard deviation (Shyr, Wang and Lin 2009).

### 3.3.6 Dynamic drape parameters

Drape researchers proposed that static drape values which had been used traditionally in studying fabric drape behaviour were insufficient and did not represent the actual motion of a fabric in a garment which is produced during the natural draping of clothes. Therefore, they proposed that studying the dynamic drapeability of fabrics was more representative and could show the actual dynamic real-life performance (Shyr, Wang and Cheng 2007).

The importance of the dynamic drape coefficients developed by Yang and Matsudaira in 1999 was evident in the investigation of different types of shingosen fabrics' (distinctive Japanese polyester woven fabrics) (microfibre) drapeability. However, there was no difference found in  $DC_s$  and the number of nodes between different fabrics tested (fabrics tested were subdivided according to fibre production, yarn processing and fabric finishing), significant differences were found between the groups when measuring  $DC_r$  and  $DC_{200}$ , as the differences became clearer in the dynamic drape parameters. The  $DC_r$  of one group (peach face type) was higher than another group (new worsted type), this relation was reversed at  $DC_{200}$ . This indicated that these parameters were important in investigating fabric drape especially fabric in garments as wearing clothes and garments includes movement (walking) (Matsudaira and Yang 2000).

Dynamic drape coefficient with swinging motion ( $D_d$ ) was proposed as it could better simulate actual body motion and was more akin to apparel appearance in use. The sample was subjected to a rotation velocity of 8.4 radian/second, the projected area of the tested sample increased to reach the maximum and then decreased to the minimum when it reached the set angle (the turn-around angle).  $D_d$  was calculated as the change of the projected area at the turn around angle (see Equation 3.20).

$$D_d = \frac{S_{Max} - S_{Min}}{\pi R_1^2 - \pi R_0^2} \times 100 \quad 3.20$$

where:  $S_{Max}$  = maximum projected area at the turn-round angle,  $S_{Min}$  = minimum projected area at the turn-round angle,  $R_0$  was radius of the circular supporting stand,  $R_1$  is radius of the fabric sample (Matsudaira *et al.* 2002).

In 2003, Matsudaira and Yang characterised 5 groups of silk woven fabrics which were classified on the basis of yarn structure using static and dynamic drape coefficients ( $DC_s$ ,  $DC_r$ ,  $DC_d$ ,  $DC_{200}$ ) and number of nodes. Differences between the fabrics tested became clearer by using a function of the combination of these five parameters produced from discriminate analysis (Matsudaira and Yang 2003b).

Tandon and Matsudaira developed a new parameter “Index of Drape Fluidity (I)” which expressed the drape fluidity better than static and dynamic drape parameters (see Equations 3.21-3.23). This was the ratio of the dynamic drapeability to the static drapeability as static drape coefficient was separated from the dynamic drape coefficient values. The higher the I value was, the softer fluid drape the measured fabric displayed.

$$I_r = DC_r/DC_s \quad 3.21$$

$$I_{200} = DC_{200}/DC_s \quad 3.22$$

$$I_d = DC_d/DC_s \quad 3.23$$

where:  $I_r, I_{200}, I_d$  were ratios of the relative dynamic drape parameters  $D_r, D_{200}$  and  $D_d$  respectively to the static drape parameter.

As the coefficient of variation CV% was used to measure the drape coefficient's dispersion within a group of fabrics. The higher the CV% was, the higher the sensitivity to differentiate between fabrics within one group was.  $I_r, I_{200}, I_d$  showed significantly higher CV% values than the relative  $D_r, D_{200}$  and  $D_d$  which indicated that these new parameters significantly distinguished between different fabrics within a group of fabrics (Tandon and Matsudaira 2010).

Shyer *et al.* used a new automatic dynamic drape measuring system employing an image analysis technique to measure static and dynamic drape coefficients of four different woven fabrics (cotton, wool, linen and silk). Their system integrated a Cusick drapemeter with a rotatable supporting sample disc, its speed reached 125 rpm. The correlation between the static ( $DC_0$ ) and the dynamic drape coefficients at four different speeds (50, 75, 100 and 125 r. p. m.) were studied. The results showed that the drape coefficient increased significantly with the rotating speed. There were high correlations between static  $DC_0$  and dynamic drape coefficients at low rotating speeds ( $DC_{50}$  and  $DC_{75}$ ). However, there was a good correlation between the dynamic drape coefficients at high rotating speeds ( $DC_{100}$  and  $DC_{125}$ ). There was poor correlation between the dynamic drape coefficients at high and low rotating speeds. So, they used the  $DC_0$  and  $DC_{100}$  as representatives for static and dynamic drape coefficients respectively in studying the effect of mechanical properties on drape coefficients. However,  $DC_0$  of cotton and linen fabrics were higher than wool fabrics, the latter

(wool) showed higher incremental rates with revolution speeds (Shyr, Wang and Cheng 2007).

### 3.3.7 Garment drape parameters

Moore *et al.* photographed and characterised the drape profiles of four-gore skirts worn by a mannequin suspended from the ceiling. The photographed pictures were digitised. The digitised data included the area of the profile of each quadrant, the distance between the apexes of adjacent nodes, the maximum distance in each quadrant between node apexes and the intersection of the axes, and the asymmetry of the right and left sides of the profile (Moore, Gurel and Lentner 1995).

Kenkare studied the evaluation and presentation of garment drape virtually, using its properties. Three drape parameters were developed: garment drape coefficient (GDC) (Equation 3.24), number of nodes (NN) and drape distance coefficient (DDC). The amount of garment drape was defined using the first two parameters while the last represented the lobedness of garment drape. These parameters were used to compare virtual and actual garment drape (measured using a 3D scanner).

$$GDC = \left[ \frac{\text{Volume of the draped garment}}{\text{Full geometrical volume of the garment form}} \right] \times 100 \quad 3.24$$

The garment's waist line and hem line contours were projected on the bottom surface to obtain a diagram with which the ratio DDC was calculated (see Equation 3.25).

$$DDC = \left[ \frac{\frac{\sum Y_i}{n}}{\frac{\sum X_i}{n}} \right], \quad 3.25$$

where: Y = maximum distance of a node from the edge of the waistline contour, X = minimum distance of a node from the edge of the waistline contour, n = number of nodes (kenkare 2005).

## 3.4 Summary

Drape is a quality which describes an important visual aspect of fabric and garment properties. Textile researchers have been working for a long time on fabric drape measurement. Generally, there were two approaches to evaluate fabric drape, objectively by measuring either fabric physical and mechanical properties related to drape namely shear, bending, and weight or drape values/attributes on a drapemeter or subjectively to relate it with the end-use product (Stylios, Powell and Cheng 2002; Stylios and Powell 2003).

However, validation of the objective measurement of fabric drape was carried out by correlating the developed method with subjective assessment as drape is basically a quality rather than a quantity. The first 3D drapemeter was introduced by the Fabric Research Laboratories in Massachusetts in 1950. Cusick in 1962, 1965 and 1968 contributed to drapemeter development and carried out significant improvements. Three British Standards concerned with drape measurement, namely, BS 5058:1973, BS EN ISO 9073-9:1998 and BS EN ISO 9073-9:2008 were based on Cusick's work. Drape researchers worked on adapting the original drapemeter to obtain detailed data with high accuracy, repeatability and ease. Therefore, several adaptations were carried out for conventional drape testers, the most important effective adjustments for studying drape included devising drapemeter with camera to capture images for the tested samples and/or a rotatable supporting disc (dynamic drapemeter). The basic drape parameter is Drape coefficient. It is measured as the percentage of 2D projection of draped fabric in its flat state. Alternative drape parameters were developed including: Drape distance ratio (DDR), Drape profile ratio, Fold depth index, Drape profile circularity (DPC), Node number (NN), Wave amplitude, Wavelength, Amplitude to wave length ratio, Amplitude to average radius ratio, Drape profile evenness, Fourier transform to original ratio and dominant to original ratio. In Table 3.1 drape researcher contributions to development of drapemeters and parameters are stated chronologically and are classified according to the level of achievement/ progress using the colour system of the taekwondo belt. The black is the highest level of progress and the green is the least from the researcher's view.

**Table 3.1 Drape researchers contribution to development of drapemeters and parameters**



Developer/Researcher	Achievement	Progress
Peirce 1930	First parameter ( <i>BL</i> ) for measuring fabric drapeability	Black
Chu <i>et al.</i> 1950	First 3D drapemeter (F.R.L.), drape coefficient and an improved F.R.L. (scanning fabric edge using optical system)	
Chu <i>et al.</i> 1960	Drape shape parameters (Area, NN, nodes shape)	
Cusick 1962	Further improvement for F.R.L. drapemeter	
Cusick 1968	Standard samples, cut and weigh method and improved optical system	
BS 5058:1973	Cusick proposal for measuring fabric drape was applied	Blue
Ranganathan <i>et al.</i> 1986	Measurement of dynamic drape using small sample making a node/fold	Blue
Collier <i>et al.</i> 1988	Photovoltaic drapemeter and a comprehensive digital DC	Red
Hearle and Amirbayat 1988	Multipurpose fabric tester	Green
Vangheluwe and Kiekens, 1993	First digital DC using number of pixels	Black
Moore <i>et al.</i> 1995	Garment drape parameters (four gore skirt)	Blue
Stylios and Zhu 1997	Investigating dynamic drape using Marilyn Monroe meter and Feature vector parameter	Black
Jeong, 1998	Alternative digital DC and New parameter "Drape distance ratio"	Blue
Hu and Chung 1998	Number of nodes variation (drape profile stability), Nodes arrangement, greatest and smallest nodes length and their position	Blue
Stylios and Wan 1999	Fold Depth Index, Alternative fold variation parameter	Blue
Fischer <i>et al.</i> 1999	Fourier coefficients as drape parameters	Red
Matsudaira and Yang 2000	Dynamic drapemeter and parameters	Black
Robson and Long 2000	Mean node severity, variability of node severity, circularity	Blue
Frydrych <i>et al.</i> 2003	More comprehensive DC	Blue
Behera and Pangadiya 2003	Minimum, average radius, amplitude/average radius	Blue
(Jevšnik S. and Geršak J. 2004)	Max and Min hang of fabric and amplitude, fold depth, wavelength	Blue
Gider 2004	Alternative method for measuring DC	Blue
Mizutani <i>et al.</i> 2005	Drape elevator (drape stages), complexity degree of drape profile parameter	Blue
Kenkare and May-plumlee 2005	Alternative digital DC	Blue



Sharma <i>et al.</i> 2005	Alternative Amplitude = $\frac{r_{i \max} - r_{i \min}}{2}$	
Kenkare 2005	Garment drape parameters	
BS EN ISO 9073-9:2008	Most dominant wave amplitude, amplitude average and variance, Fourier analysis for measuring drape, Fourier transform/original ratio, Dominant/original ratio	
Shyr <i>et al.</i> 2009	Drape profile ratio, measurement of number of nodes objectively	
Al-Gaadi <i>et al.</i> 2011	Evenness of nodes distribution parameter	

## Chapter 4

### Factors affecting fabric drape

Fabric drapeability is affected by different factors. Textile and apparel researchers have been (for a long time) interested in identifying these factors and their correlation with fabric drape behaviour.

#### 4.1 Fabric composition and structures

Backer found that yarn properties and fabric structure affect fabric drape (Backer 1948). This means that fabrics with different yarn count and/or structure would produce different drape behaviours.

Werner and James compared the drapeability of different woollen fabrics made from fine and medium wool fibres (the first had smaller diameter than the second). Fine woollen fabrics had higher drapeability than medium fabrics (Werner and James 1952).

Howorth and Oliver were interested in identifying the subjective properties which contribute to accepting (preference) or rejecting woollen suits' handle by asking a panel to refer their assessment for a property related to the handle using descriptive terms. The test was carried out by blind pair comparison of 27 commercial fabrics. The drape was used in 0.3% frequency of the decisions taken. This means that drape did not highly contribute to the evaluation of fabric handle (Howorth and Oliver 1958).

Fabric drapeability was found to have a positive relationship with yarns' float lengths while having an inverse relationship with both cover factor and yarn diameters. Fibre cross-sectional morphology was found to have a good impact on fabric drape behaviour. Chu *et al.* developed a formula for the relation between three physical parameters affecting drape in terms of drape coefficient (see Equation 4.1).

$$DC = f(EI/W) \quad 4.1$$

where the function  $f$  can involve interactions in these parameters between the warp and filling systems,  $E$  is Young's modulus,  $I$  is the cross-sectional moment of inertia,  $W$  is the weight and  $EI$  is the bending stiffness (Chu, Platt and Hamburger 1960).

Elder *et al.* found that the drape coefficient could be used as a fabric handle parameter/index as it (DC) was correlated strongly with bending length and flexural rigidity which were considered as handle properties (Elder *et al.* 1984).

Zurek *et al.* found that fibre initial tensile modulus and linear density affect fabric drape (Zurek, Jankowiak and Frydrych 1985).

According to Collier in 1991, researchers found that thickness and weight properties characterise and affect 3D materials. Collier did not find that they have an impact on fabric drape behaviour, which made him consider fabric as a 2D planar structure material rather than 3D planar (Collier 1991).

Matsudaira *et al.* investigated the impact of ratio of polymer to space in the fibre cross-section on fabric mechanical properties. They found that the greater the space ratio in the fibre cross-section was, the softer, more deformable, unrecoverable and inelastic the fabric was. However, the fibre assembly structure (yarn density and count) had higher and more significant impact on fabric mechanical properties than fibre cross sectional shape (Matsudaira, Tan and Kondo 1993).

Hu *et al.* found that the drape profile of woven unsewn fabrics became clearer, more stable and had better fold arrangement as the difference between warp and weft bending rigidity and fabric thickness increased. In seamless fabrics, two nodes always existed in the warp direction as it had higher *BR* than the weft direction (Hu, Chung and Lo 1997).

Jeong and Phillips in 1998 studied the effect of fabric physical (construction) properties namely; cover factor, yarn interaction, and weave crimp and tightness (compactness) on fabric drapeability. The cover factor was found to decrease the drapeability (drape distance ratio *DDR*) while increasing the bending rigidity and both correlations were strong but with different directions. The effect of yarn interaction on fabric drapeability was studied using two types of 3/3 (with constant cover factor) and 4/4 (with similar cover factor) twill fabrics. In the first group the fabrics had similar bending rigidity and different shear rigidity; this produced a large difference in fabric drapeability. However in the second group, the fabrics had similar shear rigidity and different bending rigidity, this produced insignificant differences in drape values. This means that differences in drape behaviour were due to changes in shear rigidity which is a result of different yarn interactions. They found positive strong correlation between the weave crimp and tightness and the bending rigidity which affected the fabric drapeability negatively. They found that the cover factor increases the instability of fabric drape (Jeong and Phillips 1998).

Kim and Slaten found that the conventional drape coefficient correlated strongly with fabric handle measured by the extraction method. In this test a circular sample was passed through a nozzle mounted on a tensile tester in 4.5 mm/min to produce a load- displacement curve. The drape coefficient was responsible for 93% of variances in fabric hand evaluation which means

that it was the most relevant fabric parameter to represent hand as evaluated by the extraction method (Kim and Slaten 1999).

Frydrych *et al.* studied the effect of the weave type and weight of fabrics on the drape coefficient measured. High drape coefficients were produced for fabrics with skew weaves and low weight. The influence of the thickness on the drape coefficient was not found (Frydrych, Dziworska and Cieslinska 2000).

Matsudaira and Yang determined that a yarn weave density effect was obvious in  $D_d$ ,  $D_{200}$  and  $D_r$  (dynamic drape parameters) and did not significantly affect the  $D_s$  and had no impact on NN. They found that dynamic drape parameters of high density fabrics were very sensitive to changed weave density (Matsudaira and Yang 2003a).

Sidabraitė and Masteikaitė studied the effect of the anisotropic behaviour of woven fabrics on drape. High correlation was found between the polar diagrams plotted using  $BR$  values and experimental drape profiles. The relation between  $BR$  in warp and weft directions was expressed by the ratio of  $B_L / B_C$  ( $B_L$  and  $B_C$  are the bending rigidity in the lengthwise and crosswise directions respectively). This ratio illustrated the anisotropy level and shape of  $BR$  polar diagrams which were repeated by drape profiles for the same measured fabrics. Three different shapes were found for bending rigidity polar diagrams and drape profiles according to this ratio: If  $B_L/B_C < 1$  ( $BR$  of warp  $< BR$  weft), the profile shape was oriented horizontally.  $B_L/B_C = 1$  showed the least level of anisotropy in two warp and weft directions. If  $B_L/B_C > 1$  ( $BR$  of warp  $> BR$  weft), the profile shape was oriented vertically. If the ratio  $B_L/B_C$  was similar for different fabrics, the fabrics could have different average bending rigidity (Sidabraitė and Masteikaitė 2003).

Önder *et al.* studied the effect of polyester type and fineness on fabric drapeability. Two-fold conventional ringspun (average denier 2.5) and a Spirospun yarn (average denier 1.7) with 76 mm cut length were used in wool blended fabrics with different lightweight constructions. Fabrics with Spirospun yarns had lower bending rigidity and higher extensibility than the conventional ones because of their higher mobility fibres. The DC was not different significantly however the number of nodes of the fabrics made from the conventional two-fold yarn was higher than the Spirospun (Önder, Kalao and Özipek 2003).

It was found that fabric density had a positive relationship with DC and negative relation with number of nodes. The first relation was stronger than the second. This was considered to be due to high  $BR$  (bending rigidity) and  $G$  (shear rigidity) of high density fabrics which decreased fabric drapeability (Uçar *et al.* 2004).

Matsudairaa *et al.* studied the effect of weave density, yarn twist and count on different polyester woven fabrics' drape behaviour. Weave density was found to decrease the number of nodes and increase static drape coefficient. However the change in  $DC_{200}$  for fabrics with different weave density, yarn twist and count was insignificant. Yarn twist increased the  $DC_s$ ,  $DC_r$  and  $DC_d$  but not by a similar rate in all types of fabrics tested. While, the yarn count had a contradictory effect on different fabrics (between increasing and decreasing drapeability) (Matsudairaa, Yamazaki and Hayashi 2008).

Chattopadhyay stated in his paper factors affecting fabric handle and drape. These were fibre fineness, length, friction coefficient and bending rigidity, yarn count, bending rigidity and twist, in addition to fabric ends and picks/cm and weave type. Fine fibres were found to improve fabric drapeability (Chattopadhyay 2008).

Quirk *et al.* compared the drapeability of basket weave and broken twill fabrics with similar density and material. It was found that the basket had less drapeability than the broken twill as it had longer floats and fewer interlacings (Quirk, Martin and Jones 2009).

Ramakrishnan *et al.* showed that viscose Knitted fabrics made from micro denier fibres had better drapeability than fabrics with normal denier fibres. This was due to the lower bending rigidity of the former because of fibre fineness which resulted in a higher tightness factor (Ramakrishnan, Bhaarathi and Mukhopadhyay 2009).

Al-Gaadi *et al.* studied the effect of composite yarns' twisting direction on drape behaviour of woven fabrics. They used three fabrics with identical structure parameters. The three fabrics had warp yarns twisted in z direction. However, each one had different weft yarns twisting directions (Z, S and Z+S). Fabrics with a combination with weft yarns in the Z direction were thinner, more rigid, more even node distribution and less drapeability than fabric with weft yarns twisted in S direction which were thicker and less rigid. Fabrics with Z+S twisting directions for weft fabrics were between fabrics with Z and S (Al-Gaadi, Göktepe and Halász 2011).

## **4.2 Fabric mechanical properties**

Chu *et al.* in 1960 studied factors affecting fabric drapeability. They found a high correlation coefficient between mono and multi planar bending characteristics (cantilever bending length and drape coefficient respectively) (Chu, Platt and Hamburger 1960).

Brand found a relation between fabric liveliness (ability of a fabric to restore its flat/planar state after being deformed in a wavy or accordion shape) and drape (Brand 1964).

Cusick in 1965 studied fabric drape dependence on bending length and shear rigidity. The results of his study established main factors affecting drape behaviour. They reported that there was a positive relationship between DC and both  $BL$  and shear rigidity. However, the change/increase in bending length values became insignificant as the drape coefficient increased. This means that as the bending length increased, it became less effective on drape coefficient. At a certain value of bending length, fabrics with different shear rigidity values had different drape coefficient values which showed the importance of shear rigidity on DC (Cusick 1965).

Hollies studied visual and tactile textiles qualities. Individuals were asked to select words related to fabric comfort response assessment within a survey form including 16 descriptors. Stiff and staticky words/descriptors (which sat in the drape category) were used by subjects with frequency 2.7% and 2% respectively which means that comfort and drape were not as correlated as other descriptors which were repeated with 100% frequency (Hollies 1989).

The drape instability (variance/deviation) was found to be strongly and positively correlated with two proposed parameters; namely residual bending curvature RB (amount of unrecovered bending strain left in a fabric after a bending recovery cycle) and residual of shear angle RS (the extent to which fabric recovers from shear deformation). Fabric with low values of RB and RS were able to keep their initial state. Strong correlations were found between bending rigidity and hysteresis and between shear rigidity and hysteresis which had good correlation with fabric drapeability (Jeong and Phillips 1998).

Morooka and Niwa studied the effect of 16 mechanical properties of 138 woven fabrics measured by KES-F on their drape coefficients. Experimental results showed that the following blocked properties affected fabric drapeability namely; bending > weight > thickness > shearing properties. Different combinations of mechanical properties were studied to find the best parameters used to predict the drape coefficient. Their derived equation to calculate the drape coefficient included the group of mechanical properties most correlated with the measured drape coefficient. These parameters were:  $\sqrt[3]{\frac{B}{W}}$ ,  $\sqrt[3]{\frac{2HB}{W}}$ ,  $\sqrt[3]{\frac{G}{W}}$ ,  $\sqrt[3]{\frac{2HG}{W}}$ , where,  $B$ ,  $W$ ,  $2HB$ ,  $G$  and  $2HG$  were the bending rigidity, weight/unit area, bending hysteresis, shear stiffness and shear hysteresis respectively. However the first parameter  $\sqrt[3]{\frac{B}{W}}$  was the most significant (Morooka and Niwa 1976).

Collier studied the correlation between fabric mechanical properties and drape values. Bending rigidity (Pierce method), bending modulus and hysteresis (pure bending tester) and shear resistance and hysteresis (Kawabata tensile and shear tester) were found to have great impact on

fabric drapeability. All bending and shearing properties were good predictors for drupe values. The most important property was shear hysteresis at 5°(Collier 1991).

Amirbayat and Hearle developed an approach to describe and analyse complex (three fold) buckling of fabrics and sheet materials theoretically and experimentally. They proposed that understanding this kind of deformation was the basis of analysing more complex buckling, determining the suitability of a material (fabric) for a product involves such buckling experimentally and designing fabrics theoretically using the relation between its structure and the relevant complex deformation (Amirbayat and Hearle 1989b). They introduced two dimensionless parameters  $J_1$  and  $J_2$  which could be used to analyse the deformed shapes of fabrics. These groups were characterised either by the energies involved in producing this deformation or the material properties and dimensions (see Equations 4.24.3).

$$J_1 = \frac{Yl^2}{D} \quad 4.2$$

$$J_2 = \frac{\gamma l^3}{D} \quad 4.3$$

where:  $Y$  was the membrane modulus = (force/width ÷ strain),  $l$  was the characteristic length defining the size of the material,  $D$  Bending stiffness,  $\gamma$  was the areal density (mass/area).

As fabric drupe was a form of double curvature, they studied the relationship between the drupe coefficient and these dimensionless parameters using four different fabrics with different sample diameters. The DC was correlated with  $J_1$  and  $J_2$  with correlation coefficients -0.56 and -0.89 respectively ( $J_2$  was more correlated with the drupe coefficient). They noted that other dimensionless parameters varied with sample size, therefore these correlations were not the final result, which means that the drupe coefficient is not only affected by (function of)  $J_1$  and  $J_2$ , but was affected by other parameters such as the full set of anisotropic in-plane (membrane) and out-of plane (bending) effects (Amirbayat and Hearle 1986a; b).

Okur and Gihan studied the correlation between traditional drupe coefficient and mechanical properties measured on a FAST system. The highest correlation was found with shear rigidity and then the bending properties and extensibility at 45°. A positive relationship was found between DC and shear and bending stiffness. Stepwise regression analysis showed that bending length in the warp and weft directions and extensibility in the bias direction at 5 gm/cm were the best predictors for DC (Okur and Gihan 1993).

According to Hu, Sudnik in 1972 studied the relationship between the drupe coefficient and bending length. He observed that the ranges of DC and

*BL* values of fabrics used in apparel making ranged between 20-80 % for the first and 1.5-3 cm for the latter (Hu 1997).

Hu and Chan studied the effect of the sixteen mechanical properties measured by the KES-F on woven fabric drape coefficient measured by a Cusick drapemeter. The following eight properties out of the sixteen had high correlation coefficients (significant at 90-95 % levels) with drape coefficient: the bending stiffness > bending hysteresis > shear hysteresis at 5 > tensile linearity LT at 0.5 > shear stiffness > weight > mean deviation of friction coefficient MMD. LT and MMD entered the analysis unprecedentedly and highly correlated with the drape coefficient. Compression properties were not correlated with fabric drapeability. They found that bending and shear hysteresis had higher impact on drape than stiffness as these properties included internal friction which played an important role in complex fabric deformation (Hu and Chan 1998).

Kim and Slaten found that highly drapeable fabric had low bending stiffness (measured by the extraction technique). The deformation of fabric tested on both drape and extraction tests was similar. The static friction coefficient (SFC) showed lower (negative) correlation with drape than with kinetic friction coefficient as highly drapeable fabrics had rougher and looser surfaces which required higher force for the sled to move on the fabric which produced high SFC. Drape coefficient showed correlations with hand force, weight, thickness, flexural rigidity, roughness, static coefficient, kinetic coefficient friction with *r* values 0.86, 0.86, 0.93, 0.82, - 0.56, -0.72, -0.7 respectively. From multiple regression analysis, *BR*, *DC* and *SFC* were the more effective parameters on fabric hand (Kim and Slaten 1999).

Frydrych *et al.* investigated the mechanical parameters affecting drape properties of wool and wool like woven fabrics. They investigated the potential of obtaining correlations between mechanical properties measured on high stress mechanical properties testers (Instron) with drape parameters, as low stress mechanical properties testers were not always available in their country. The highest correlation was found for drape coefficient with: average bending rigidity ( $R^2 = 0.89$ ), initial tensile modulus (ITM) in warp direction ( $R^2 = 0.68$ ), formability (*BR*/ ITM) in the weft direction ( $R^2 = 0.64$ ) (Frydrych, Dziworska and Cieslinska 2000).

Mizutani *et al.* tested the dependence of node generation on fabric mechanical properties; namely bending rigidity and recovery. Bending rigidity and recovery of different woven fabrics were measured at warp, weft and both bias directions. The bias direction had the lowest bending rigidity and recovery values, the nodes were generated in this direction (Mizutani, Amano and Sakaguchi 2005).



The effect of the sixteen physical properties measured by KES-F (which are grouped in six sets) on both static and dynamic drape coefficients were investigated. The results supported previous research studies' findings that the bending and shear properties had a high effect on fabric drape behaviour. Although the effective parameters were different for the tested fabrics, the bending property was found effective on all fabrics. Low effect properties were considered as complimentary properties which would complete the representation of fabric drape behaviour (Shyr, Wang and Cheng 2007).

Behera and Pattanayak found good negative correlations between fabric drapeability and bending rigidity, shear rigidity, tensile energy (analogous to initial modulus) and compressional properties. However, positive strong correlations were found between drapeability and extensibility at low loads (Behera and Pattanayak 2008).

Tandon and Matsudaira found that bending and shear properties measured on KES-F correlated with static and dynamic drape values. Bending stiffness, ability to shear, tensile behaviour, surface friction, mass per unit area and thickness had impact on fabric drape. Stiffness to weight ratio affected fabric drapeability negatively (Tandon and Matsudaira 2010).

Tokmak *et al.* studied the relationship between FAST, KES-F and Cusick drapemeter values. FAST and KES-F were strongly correlated with regard to the equivalent parameters measured on both of them. They found that the drape coefficient correlated strongly with FAST bending and shear rigidity with  $R^2 = 0.9$  and  $R^2 = 0.8$  respectively (Tokmak, Berkalp and Gersak 2010).

### **4.3 Fabric finishing**

It was found that woven fabric relaxation treatments reduced the frictional pressure at intersection points between warp and weft yarns which consequently reduced both bending and shear rigidities and affected fabric drapeability (Collier 1991, Grosberg 1966).

Michie and Stevenson investigated the possibility of enhancing aesthetic properties including drapeability of chemically bonded nonwoven fabrics without affecting their tensile strength. The approach of subjecting commercial nonwovens to extension in order to allow them to relax was applied. It was found that stretching fabrics for higher than 3% decreased initial modulus, shear modulus, bending length, and drape coefficient (from 96% to 91%) and slightly decreased rupture stress. On the other hand tensile strength and elastic recovery were not highly affected. They found that this approach improved fabric drapeability but still did not reach normal textile behaviour (DC = 80% would be acceptable) as extending the study was recommended. Their study indicated the role of bending length in

identifying drape behaviour more than shear resistance (Michie and Stevenson 1966).

Matsudaira and Yang studied the effect of weight reduction ratio (WRR) on drape behaviour of shingosen fabrics. They reported that increased weight reduction ratio increased  $NN$ ,  $D_r$  and  $D_d$  (stabilised at around 23% WRR) while reduced  $D_s$  and  $D_{200}$  which reached stable state at around 20% WRR. High ratios of WRR were responsible for stabilising the drape parameters (Matsudaira and Yang 2003a).

Matsudaira *et al.* extended this study to investigate the effect of different finishing processes (not only the weight reduction) on drape behaviour. Shingosen fabric was finished using two different methods to make two sub groups A and B. In group A, a washer was used in the relaxation process and 16% weight reduction was used, however in group B, a jet machine in the relaxation process and 23% weight reduction was used.  $D_s$ ,  $D_{200}$ ,  $D_d$  and  $D_r$  were not affected by the dyeing and raising processes. The applied finishing processes (specially the relaxation) increased the number of nodes,  $D_d$  and  $D_r$ , and decreased  $D_s$  and  $D_{200}$ . However, the washer relaxation effect was stronger than the jet machine relaxation. The effect of high weight reduction ratio was well observed with the decrease of  $D_{200}$  and increase of  $D_r$ . However, there were differences between samples A and B with respect to drape parameters, parameters at the final output (end of finishing stages) were similar (Matsudaira *et al.* 2003).

Frydrych *et al.* studied the effect of different types of finishing treatments (starch and elastomeric) on fabric drapeability in terms of Polish drape coefficient. The mean standard deviation of starch samples was higher than elastomeric samples which means that they have lower stability than the other treatment. It was observed that elastomeric finishing had a significantly increased drapeability effect than starch treatment (Frydrych, Dziworska and Matusiak 2003).

Agarwal *et al.* studied the effect of wash-ageing and use of fabric softener on viscose and polyester knitted fabric drapeability. Measurements were carried out after one and 40 washings with and without softener. In viscose fabrics the highest effect was for construction, followed by prolonged washing and then the use of softener. In the polyester fabrics they were the same factors, however the second was replaced by fibre fineness. Using softeners decreased the drape coefficient of viscose and polyester knitted fabrics tested. Initial washing's effect on drape were not as significant as prolonged cycles. Maximum effect on drapeability was for the 20<sup>th</sup> washing using softener. The DC increased after that (at the 40<sup>th</sup> washing) the viscose fabrics however approximately kept more constant than the polyester fabrics. This increase was suggested to be due to the alteration of loop

shape and/or deposited calcium and/or magnesium in the fabric (Agarwal, Koehl and Perwuelz 2011).

#### 4.4 Effect of test procedure on stability of drape values

Morooka and Niwa investigated the applied method for mounting samples on drapemeter in terms of drape coefficient values reproducibility. Three methods of mounting tested specimens were used. These were  $D_j$ ,  $D_n$  and  $D_f$  referring respectively to drape coefficient with shaking the mounted sample together with the supporting disc up and down several times before testing, adjusting the tested sample before testing in state to produce four nodes and the last was mounting the sample without touching it by means of a board with a hole with similar diameter to the supporting disc. The last method exhibited the lowest deviation of drape coefficient followed by the second and the first method had the highest variation. The first (shaking) method exerted different forces on the measured sample in each measurement which made the ratio  $\sqrt{\frac{2HB}{W}}$  highly scattered. This ratio which represented the hysteresis in bending per unit weight (frictional term)  $\sqrt{\frac{2HB}{W}}$  was found to have an effective role on the measured drape coefficient deviation. The higher this ratio was, the higher the deviation of DC values were (Morooka and Niwa 1976).

Jeong proved practically that the initial state of the tested samples affects the drape parameters. Different methods of mounting the samples were applied i.e. without remounting on the supporting disc and also with remounting between successive measurements. The remounting method had higher node number variation. Therefore; it was worked out that the same drape shape could be obtained using the same initial state of the sample. The initial state affects the number of nodes which in turn has an impact on the drape values (drape coefficient and drape distance ratio). Consequently; the initial state of the fabric affects the drape values. He found that different fabrics have different sensitivity for mounting methods. Moreover, different methods of mounting fabrics gave different drape values. Drape distance ratio had lower variation than the drape coefficient; he referred this to the basis of measurement for each parameter, as the first is based on length units while the second on the area units (Jeong 1998).

Behera and Pangadiya pointed to the importance and effect of sample placement method on result variance (Behera and Pangadiya 2003).

Mizutani et al compared the repeatability of their drape elevator and a conventional Japanese drapemeter. Drape coefficient values of the drape elevator were higher than the conventional tester and had lower standard

deviations (less than half of the conventional rotational drape tester) which means that it had higher reproducibility. This high error for the conventional tester could be due to the falling movement with inertia of rotation of the rotated sample tested resulting from the sample rotation when placed/mounted on the tester. Therefore, drape shape resulted in complex unstable conditions. On the other hand the drape shape in the drape elevator was generated gradually during moving the table downwards which provided less disturbance than the conventional drape tester. This means that the rotation movement of the conventional Japanese drape tester caused disturbance of the drape shape produced low repeatability. However, the drape elevator kept the sample tested more stable during testing (Mizutani, Amano and Sakaguchi 2005).

Al-Gaadi *et al.* studied the effect of exerting dynamic impact on drape values measured as they simulated the real use of fabrics. Three annular discs with different inner diameters (21, 24 and 27cm) were used to push the sample tested through them upwards. The test started with the sample lying on the tester's base and mounted on a circular supporting disc with 18cm diameter. It was found that the ring with the smallest inner diameter produced the lowest drape value deviation (higher reproducibility) and more even node distribution. Moreover, it had the most effect on the drape behaviour by producing lowest DC values and the highest number of nodes (Al-Gaadi, Göktepe and Halász 2011).

#### **4.5 Supporting disc size**

Cusick found that the number of nodes increased as the supporting disc diameter decreased. The drape coefficient did not change as significantly as the number of nodes (Cusick 1962).

The effect of different supporting discs diameter (3 and 5 inches) on drape values obtained from measuring the same sample diameter was investigated by Collier in 1991. The 3 inch diameter disc produced longer overhanging parts of fabric than the 5 inch diameter's. They found experimentally that the drapeability of the fabrics tested increased with the smaller disc diameter. The coefficient of variation was lower for the 3 inch disc samples which means higher accuracy (Collier 1991).

#### **4.6 Controlling drape behaviour of fabric**

Tandon and Matsudaira compared static and dynamic drape coefficients and the indices of the drape fluidity of 20 wool fabrics and 4 types of shingosen fabrics. They found similarity between one of the wool fabrics and the shingosen fabrics which was characterised by smooth and fluid drape behaviour. This means that wool fabrics with high drapeability could be

engineered using suitable production parameters for the fabric starting with the fibre content through the yarn to the fabric structure and mechanical properties endowed by the finishing process. This would be useful information for researchers working on engineering fabrics for certain purposes (fit for purpose), as they are able to engineer fabrics with high drapeability using the existing knowledge and rules with respect to the selection of fibre, yarn, fabric and finishing production and process criteria (see Table 4.1) (Tandon and Matsudaira 2010).

**Table 4.1** Levels to control the development of drapeable fabrics (Tandon and Matsudaira, 2010)

<p>Fibre selection</p> <ul style="list-style-type: none"><li>• Fibre type</li><li>• Fibre denier (diameter)</li><li>• Fibre cross sectional shapes</li><li>• Fibre surface</li></ul>
<p>Yarns (structure)</p> <ul style="list-style-type: none"><li>• Yarn spinning route (woollen,worsted, cotton-spun, multifilament, SoloSpun,etc.)</li><li>• Count</li><li>• Twist</li><li>• the number of plies (singles or two or three-ply)</li></ul>
<p>Fabric construction</p> <ul style="list-style-type: none"><li>• weave or knit type,</li><li>• threads/cm (warp and weft sett,courses and wales/cm),</li><li>• fabric cover</li><li>• thickness</li><li>• weight.</li></ul>

## 4.7 Time

A draped fabric is subjected to the force of gravity which could produce a deformed shape over time. This change could be due to creep in fabric and yarn slippage (shear) (Vangheluwe and Kiekens 1993). Therefore, time is one of the factors affecting fabric drape behaviour. Therefore, textile and clothing researchers interested in fabric drape parameters were interested in studying time's effect on fabric drapeability.

Cusick in 1965 suggested tracing the projected shadow of sample tested immediately (within 15 seconds) after raising the supporting disc and repeating continually as fabric deformation changes with time (Cusick 1965).

Vangheluwe and Kiekens found that ten minute period of time was sufficient to work out the relationship between them. From their plots, drape coefficient decreased exponentially with time. Equation 4.4 theoretically governed the relationship between drape and time.

$$D(t) = A + \sum_{i=1}^n B_i e^{-t/T} \quad 4.4$$

where: A, B, e, t varied according to the experimental values used and could be easily calculated using statistical software (Vangheluwe and Kiekens 1993).

Jeong in 1998 studied time dependence of drape coefficient using an image analysis method. They measured the drape coefficient of four fabrics over around eleven minutes period of time. Their experimental results agreed with Vangheluwe and Kieken's that the drape coefficient decreases gradually with time and this reduction is due to the relaxation of fabric mechanical properties. The DC became stable at around the 7<sup>th</sup> minute. This steady state could be easily checked using the image analysis method (Jeong 1998).

Hearle and Amirbayat designed a multipurpose fabric tester, drape was one of the properties which could be measured using this device. It was devised to measure drape and other surface properties as a function of time (Hearle and Amirbayat 1988).

Zunic-Lojen and Jevsnik studied the effect of time on drape parameters over a long period of time (24 hours). Drape coefficient, number of folds and maximum and minimum fold amplitudes of eight woven fabrics were measured using a Cusick drapemeter coupled with an image analysis system. These measurements were carried out for samples with two different diameters 30 and 36 cm for each fabric over four periods of time 2, 4, 6 and 24 hours after the first measurement (four intervals were used 0-2, 2-4, 4-6, 6-24 referred to as 1<sup>st</sup>, 2<sup>nd</sup>, 3<sup>rd</sup> and 4<sup>th</sup> interval respectively). They found that the drape coefficient decreased with time regardless of sample size (large or small). The most distinctive change (decrease) was in the first stage. The rate of the drape coefficient reduction was different from fabric to fabric. Reduction rates were similar in the first and fourth stages and the change rate was lower in the second stage than the first. Generally, the change was significant in the first three stages (0-6 hours) than the fourth (6-24). Plain weave fabrics with the lowest weight and bending rigidity had the highest percentage of decreasing rate, while weft rib fabrics with the highest weight had the lowest decreasing rate. They agreed with Vangheluwe and Kiekens that the exponential function ( $y = A x^B$ ) was the best to represent the curves of drape coefficient change with time with  $R^2$  values higher than 0.79, however large samples presented higher  $R^2$  than small ones. They found that maximum and minimum amplitudes went down with time as the drape

coefficient did, however the number of folds was constant. The change in the maximum and minimum amplitudes alone did not give evidence for the change of the drape behaviour as they were just parameters for two folds and their changes were insignificant. So, they could not depend on their results without connection with the rest of the parameters. The change of small and large samples were different. Smaller samples had higher drape coefficient values and rate of reduction than larger ones. However, the larger samples had higher weight with around 67.41%, there was not significant correlation observed between this increased weight and the change of drape coefficient with time (Jevšnik and Žunič-Lojen 2007).

Sun developed a tester to measure the angle of drape of a cross shaped sample in warp and weft directions from which the bending length was calculated. He suggested leaving the tested samples for 1 min to relax in order to obtain stable samples. He found a difference between readings of drape angles on mounting the samples and after 1 minute as the latter was lower in both main directions. Higher correlation coefficient was found between values of bending length using this tester after 1 minute and Shirley and FAST 2 bending meter's values than instant readings (Sun 2008).

The factor of time plays an important role in the computer graphics area. Fabric drape researchers interested in virtual simulation have been working on the challenge of engineering a reliable, efficient and accurate model of draped fabric. Different computer techniques were developed to achieve this challenge. All of them were based on using drape parameters and variable factors affecting drape significantly (Collier *et al.* 1991; Pandurangan 2003; Zunic-Lojen and Jevsnik 2007). Time was an important variable in the derived/applied equations which produce a time-variable deformation for virtual fabric drape simulation (Breen, House and Wozny 1994; Stylios and Wan 1999; Hu, Chen and Teng 2000; Xiaoqun *et al.* 2001; Chen, Hu and Teng 2001; Magnenat-Thalmann and Volino 2005).

## **4.8 Garment Drape**

### **4.8.1 Fabric drape versus garment drape**

Ng *et al.* investigated the difference between fabric and garment (flared skirt) drape supported on the same body (column). Two drape profile parameters, maximum hem angle of the front view ( $\alpha$ ) and the number of nodes did not show a difference. However, DC, area of cross-section top view (A), average wave height in the cross-section of the top view (h) and maximum width of hemline of the front view S showed a difference. Correlations between the fabric and garment drape difference and the sixteen mechanical properties measured on the KES-F showed that two compression properties (stress/thickness curve and compression energy) had strong negative correlations with the stated difference. These results confirmed that garment

drape will not be predicted precisely using the fabric drape parameters as they behaved differently in their study. Therefore, garment drape is independent of fabric drape assessment. They expected that their investigation would have positive impact on apparel design, end use of fabrics and its simulation in CAD systems (Ng, Hui and Tam 2002).

#### **4.8.2 Grain alignment**

Fabric grain line position in a piece of garment affects its appearance. As the garment maker needs to tilt patterns off grain within the marker to increase the fabric efficiency by reducing the manufacturing cost. Positioning patterns incorrectly (off-grain) could cause undesirable drape appearance. Therefore a study was carried out by Orzada *et al.* to investigate the effect of grain alignment (tilt degree) of the pattern in the marker on fabric drape. Fabrics suitable for straight skirt style (gabardine, light and heavy denim) were used in the investigation. Computer software was used to design and mark patterns on the fabric. Four different tilt angles (0, 3, 6, and 9) were applied to obtain 12 different combinations of two halves of a circular sample (sewn pairs) with similar or different tilt degrees. 0 tilt degree referred to a pattern aligned with the grain line. 0/0 tilt sample was used to present the seam effect on fabric. However, a seamless sample from each fabric was used as a control sample. Images for samples draped with their face up were used to simulate the action of the garment drape. However, there was not a significant correlation (consistent) found between tilt angle and drape coefficient, there was a significant effect on drape symmetry and appearance. But, there should be a correlation found between the tilt angle and the drape behaviour (as it presumed in text books as mentioned in this paper). So extending this study with wider range of fabrics was suggested (Orzada, Moore and Collier 1997).

#### **4.8.3 Interfacings**

Koenig and Kadolph studied the effect of seven different fusible woven, knitted and nonwoven interfacings (namely; plain woven; tricot warp knit; weft-insertion tricot, warp knit; random web, dry-laid nonwoven; oriented web and spunlaced nonwoven) on broadcloth fabric drape. All interlined fabrics had significantly higher DC values than the original fabrics. The least effect (especially on the drape configuration) was found for tricot knit and spun laced interfacings which had the lowest rigidity. Each interfacing category produced interfaced fabric with similar drape profile/configuration which was independent from other groups. Drape profile of interfaced fabrics were found draping parallel to the main direction with higher rigidity, however parallel to the bias direction with lower *BR* than two main directions with equal *BR* (Koenig and Kadolph 1983).

Collier *et al.* studied the effect of interfacing type on shear stiffness *G* as an indicator of its effect on fabric drapeability. Woven face fabrics (F)



(presented range of weight and yarn type) were interlined with four different interfacing fabrics: fusible and nonfusible from woven and nonwoven to produce different composite fabrics (C) (interfaced fabric). They found that shear rigidity of the end product (interlined garment) was not just a sum of the components, as the interface type had an important impact on composite C shear stiffness. Therefore, ratio (composite shear rigidity) to Sum (sum of individual component shear rigidities) was proposed to study the relation between face and interface fabrics and how this relation affected composite behaviour. Ranking of interfacing fabrics' shear rigidity was as follows: nonwoven nonfusible > N fusible > woven fusible > woven nonfusible. However, nonwoven nonfusible had the highest shear stiffness, woven fusible had the highest effect in increasing the composite shear stiffness as it had more than an additive effect (means  $G_{\text{composite}} > G_{\text{Sum}}$ , as the additive character results  $G_{\text{composite}} = G_{\text{Sum}}$ ). This was due to adhered yarns which were free and able to slip on each other before joining to the face fabric. Therefore, the adherence increased the shear stiffness of the interface fabric itself and stiffened the face fabric as well. Moreover, the higher the face fabric stiffness was, the lower the resin penetration was, which decreased the effect of the adhesive material on changing the face fabric behaviour. woven nonfusible interlinings were less than additive  $G_{\text{composite}} < G_{\text{Sum}}$  ( $G_{\text{composite}}:G_{\text{Sum}} < 1$ ). The way of joining the face and interface fabrics together had an important role in this weak effect of Wn interlining on the produced composite as in this study the two layers were only stitched at the four corners of the squared samples. Therefore each of the joined layers behaved as independent layers rather than an identical composite which consequently reduced the load transference. One of the two layers became compliant (capable of being controlled) and the other noncompliant (controlled the composite shear behaviour). The stiffer layer was the more comparative part (controlling) in the composite behaviour. Two important factors dominated the effect of woven interlinings on composite shear stiffness: interconnection density (stitching or fusing) and the ratio  $G_{\text{interfacing}}:G_{\text{fusible}}$ .

The ratio between interlining and face fabrics shear stiffness  $G_I:G_F$  affected the  $G_{\text{composite}}:G_{\text{Sum}}$  ratio. This was obvious when one interlining fabric was used with two different face fabrics (in the first  $G_{\text{interfacing}}/G_{\text{fusible}} < 1$  and the second  $G_{\text{interfacing}}/G_{\text{fusible}} > 1$ ). The first produced  $G_{\text{composite}}:G_{\text{Sum}}$  values close to 1 (slightly higher), while the second produced  $G_{\text{composite}}:G_{\text{Sum}}$  values significantly higher than 1. Therefore, the lower stiffness face fabric had a stronger impact on increasing the composite fabric than the sum shear stiffness.

They determined that the existence of the nonwoven structure was more important than the resin existence and generated composite values were nearly additive (except in N nonfusible composites which had  $G_{\text{interfacing}}$

( $G$  fusible  $< 1$  ). Negligible effect was found for the face fabric on composite  $G$  values including nonwoven interlinings due to the very high shear stiffness of the latter, and limited effect of the fusible resin on the composite as it was applied using a dotted pattern rather than a continuous pattern which produced a composite with lower shear resistance (Collier, Paulins and Collier 1989).

According to Chung *et al.* and Hu *et al.* ,Suda and Nagasaka found that, both bending rigidity and drape coefficient increased with the number of layers and width in circular samples with bonded circular edges, however, the number of nodes decreased. Four layers of radial bonded nonwovens affected the number of nodes significantly (Chung, Hu and Lo 1997; Hu, Chung and Lo 1997).

Both woven and knitted interlinings increased the DC with a range of 33.5 - 129.18%. Woven interlinings had more effect than knitted. Shell fabrics' areal density affected the increment rate of DC due to fused interlining, the increment rate of DC decreased with increased weight of shell fabrics (Sharma *et al.* 2005).

#### **4.8.4 Seams**

Garment drape researchers found that it is unrealistic to study drape without taking into consideration different processes used to convert fabric into garments, as fabric must be sewn to be made into a garment. Seam existence, number, allowance, position, direction, type and stitch type effect on bending properties, drape coefficient, drape profile and number, length, size, maximum and minimum of nodes were investigated.

##### **4.8.4.1 Seam existence**

Jevšnik and Žunič-Lojen found that addition of seams increased fabric DC, as seamed fabric is two fabric parts connected to each other by a thread. Additional fabric lies under the fabric's face and the used thread increased fabric bending rigidity (Jevšnik and Žunič-Lojen 2007). The increment range was between 13.35-42.78% (Sharma *et al.* 2005). Introducing seams decreased the number of nodes or kept it constant. In seamless fabrics, 2 nodes appeared in the warp direction. However, 1 or 2 nodes appeared in the seam direction for most fabrics. The drape profiles of seamed fabrics were different from unseamed samples in terms of node size (form) and distribution. In seamed samples, minimum fold amplitude was lower and maximum fold amplitude was greater than in unseamed samples (Jevšnik and Žunič-Lojen 2007).

#### **4.8.4.2 Seam allowance (SA)**

##### **Bending length**

Bending length was affected by seam allowance (SA). Vertical (VS) and horizontal seams (HS) (perpendicular and parallel to the hanging edge of cantilever *BL* strip respectively) were used. In VS samples, *BL* increased with increased SA initially between (0-1 mm) and remained constant while SA increased. In HS samples, initial insignificant increase of seam allowance decreased the *BL* which then increased with increased SA. But this increment's magnitude was not comparable with the increment rate caused by VS. (Hu, Chung and Lo 1997).

Chung *et al.* agreed with Hu *et al.* as they found that *BL* had initial rapid increase in the stage between 0-1 mm SA. The increment rate became less after that and reached the maximum at 5mm. Sometimes, the *BL* decreased after this stage or became constant. Fabric weight affected this increment rate as for light weight fabrics *BL* increased less than for heavy fabrics with increased SA (Chung, Hu and Lo 1997). The effect of the seam allowance was significant in vertical seam samples as 1 mm seam allowance increased the bending rigidity of the fabric with 3-4 times (9-11 times for the bending hysteresis) than seamless fabrics. Seam allowance with 10 mm increased *BR* with 14 - 16 times and bending hysteresis with 26 - 33 times seamless fabrics (Chung, Hu and Lo 1997; Dhingra and Postle 1980).

Dhingra and Postle found that bending rigidity (KES-F) was affected by seams but this was not true for shear rigidity and hysteresis. This effect on bending behaviour depended on seam allowance and direction. VS (with SA: 1 and 10mm) and HS (with SA: 1 and >2.5mm) were used. However, the horizontal seam increased the bending rigidity (with SA > 2.5mm), its increment rate was not comparable with the vertical seam effect which was 3-4 times the first effect. This was due to more free fabric in the horizontal seam sample than the vertical. As in pure bending tester sample tested was held between two clamps parallel to the bending axis during test. This made the movement of seam allowances restricted in the vertical seams and free in the horizontal seams. Therefore, samples with horizontal seam had lower bending rigidity than the vertical samples (Dhingra and Postle, 1980).

##### **Drape coefficient**

DC was increased with SA and then decreased after reaching the maximum. Its increment rate was lower than the *BL*. Maximum DC was at 1 cm while the maximum *BL* was at around 2 mm. (Hu, Chung and Lo 1997). Heavy weight fabrics were more sensitive than light weight for increased DC due to increased SA (Chung, Hu and Lo 1997). Hu and Chung found that increased SA of radial seams (RS) (seam between two edges of circular sample passing through the centre) slightly affected DC which had rapid increase

between 1-5 mm SA and insignificant increase after this period. DC trend curves of 1, 2 and 4 RS were similar; however the latter was the most stable and clear with variable SA (Hu and Chung 1998).

### **Drape profile (DP)**

Variable SA was not effective on drape profile appearance and nodes' orientation (Hu and Chung 1998).

### **Number of nodes (NN)**

Increasing the SA reduced NN along the unseamed parts, and light weight fabrics were less sensitivity than heavy weight fabrics with changed SA (Hu and Chung 1998).

### **Node size**

Increasing the SA produced large node along the seam but it was not a significant change (Hu and Chung 1998).

#### **4.8.4.3 Seam position**

Hu *et al.* found that in HS samples: The nearer the seam to the hanging edge was, the lower the *BL* was.(Hu, Chung and Lo 1997). Variable circular seams (CS) position in circular samples with respect to the sample centre had significant impact on DC values. The most significant increasing effect for DC was for a seam just off the supporting disc as seam allowance was still hanging on the sample disc and increased sample support. DC decreased with CS movement towards sample edge to reach the lowest value when CS was at the edge of fabric specimen (Hu and Chung 1998).

#### **4.8.4.4 Seam direction**

##### **Bending length**

VS had higher effect than HS in increasing *BL* values. Seamless samples had *BL* values higher than HS samples. (Hu, Chung and Lo 1997).

##### **Drape coefficient**

DC of knitted fabrics with seams in the wales direction was slightly higher than samples with courses direction seams as it raised the rigidity of the fabric in the wales direction which had less rigidity than the courses direction (Uçar *et al.* 2004).

##### **Drape profile**

Nodes were generated in seam direction because seamed part had higher bending stiffness than other parts, so seams support their parts and generated nodes in its direction (Hu, Chung and Lo 1997).. Seam in the

courses direction made the fabric DP more stable in the courses direction and produced higher correlation between dependant (DC, NN) and independent (seam number, fabric density) variables as correlations in wales direction were lower than the courses direction due to the low rigidity in the former (Uçar *et al.* 2004).

### **Number of nodes**

In samples tested with radial seams (warp and/or weft directions), 2 and 4 folds dominated the warp or weft directions, and weft and warp directions respectively (Hu, Chung and Lo 1997). Jevšnik and Žunič-Lojen found two or three nodes in the weft direction seam (Jevšnik and Žunič-Lojen 2007).

#### **4.8.4.5 Seam number (SN)**

##### **Drape coefficient**

Seam number increased fabric DC. The more added seams there were, the more obvious effect for seam was (Uçar *et al.* 2004). Increased DC due to increased SA in 1 and 2 RS samples were not as effective as vertical seam on *BL* values. However, 4 RS had the highest DC values and their increment rate was similar to the *BL* samples which increased initially between 1 - 5 mm SA and became stable with increased SA after that. This increment rate was more stable and consistent in 4 RS samples than 1 and 2 RS samples. This means that the effect of radial seams was obvious by added (accumulated) number of seams (Chung, Hu and Lo 1997).

Hu and Chung agreed with these findings as they found that DC increased with the addition of radial seam, but this effect was more obvious with increased seam number. Change in DC was higher and more stable and consistent in 4 seams samples than 1 and 2 seams samples. Fabric weight had an influence on the effect of SN on DC as increased SN had more impact on increasing DC of heavy weight fabrics than light weight ones. (Hu and Chung 1998).

##### **Drape profile**

Unseamed fabrics had unstable DP. Adding a seam swung the highest node to the seamed part. One RS changed the DP of seamless fabric and acted to locate the nodes but not exactly at its middle. It had irregular nodes' orientation at the unseamed parts, while seamed parts stabilised the nodes at it. Number of radial seams had significant effect on DP. The more seams added to a fabric were, the more stable the drape profile was. Thus, drape profiles of fabrics with both two and four seams had more regular nodes arrangement than one seam. Four seams fabric drape profile was the most stable one and not affected by varied SA. They had stable nodes which were mostly found along the seamed directions orienting themselves regularly in the seams direction. The drape profile of fabric with circular seam was

entirely different from the drape profile of fabric with RS as nodes did not stay at any specific position. Number of seams showed great effect on drape profile of heavyweight fabrics, but very little effect on lightweight fabrics (Hu and Chung 1998).

### **Number of nodes**

Unseamed and one seam fabric nodes number were unstable, the more added seams were the more stable NN was, as NN of 2 seams fabrics were more stable than seamless and one seam samples. In 2 seams fabrics, 4 nodes existed at the seamed parts. However, NN were fixed at 7 or 8 in an octagonal arrangement in 4 RS samples. (Hu and Chung 1998).

There were negative correlation between NN and SN. As, addition of seams decreased fabric drapeability as seamed parts bent less than unseamed parts. This relation was slightly stronger than DC - SN relation (Uçar *et al.* 2004) .

### **Nodes size**



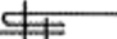

In fabrics with no seams, the greatest and smallest node lengths were found in any position on the draped fabric. Seamed parts always had the longest node lengths and did not have the lowest. In lightweight fabrics, node length was more sensitive when adding RS (Radial Seam) than DP and DC. Addition of circular seams did not affect the node length and was not so different from unseamed fabrics (Hu and Chung 1998). Seamed parts had wider nodes than other parts (Uçar *et al.* 2004).

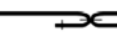
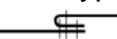
#### **4.8.4.6 Seam type**

##### **Bending length**

SPS (side press seam) increased *BL* more than OPS (open press seam), this was considered to be because of the higher localised fabric weight generated due to pressing both sides of seam allowance on one side. For any seam type, heavy weight fabrics were more affected than light weight fabrics because of the increased stiffness (Chung, Hu and Lo 1997).

##### **Drape coefficient**

Effect of four types of lockstitch seams (LS1  , LS2  , LS3  and LS4  ) on fabric drapeability were studied. LS1 had the lowest DC values while the others showed similar effect in raising the DC values.

Jevšnik and Žunič-Lojen studied the effect of two seam types on DC values and found that S2  seam type had higher DC (seam allowance turned in one direction) than S1  . The effect of seam type on NN

was clear in bias and double warp and weft seams and it was different according to the fabric characteristics (Jevšnik and Žunič-Lojen 2007).

#### **4.8.4.7 Girth ease allowance**

Cui *et al.* studied the relation between fit of clothing and fabric properties (including drape). As it was noticed in the clothing industry that garments with similar size and style made from different fabrics produce different levels of fitness. The relation between girth ease allowance (GEA) and fabric drape (in terms of traditional drape coefficient) was investigated. GEA is the difference between the body measurement and the pattern. The ease differs according to the type and style of garment.

Clothing samples (jacket) made from 12 different fabrics with the same size and style were scanned (using a 3D scanner) on a standard mannequin. Images for the mannequin wearing and naked were scanned to work out and analyse the GEA at different parts on the mannequin/garment (namely bust, waist, and hip). They determined that garment drape was more dependent on GEA of waist  $r = 0.65$  and hip  $r = 0.82$  (linear relation) more than the bust (nonlinear relation  $r = 0.27$ ). GEA at the waist and bust was significantly larger than the hip. Regression models/equations for these correlations were worked out and would provide important information for apparel industry workers (Cui, Zhang and Wang 2010).

#### **4.8.5 Deformed garment drape**

Garment drape is expected to be equivalent along its sides but deformed/distorted fabric drape would affect garment degree of comfort and appearance. Some aspects of unpleasant drape would result from twisted seams at the front and back of the wearer's body or different number of nodes along the garment edge. A distorted drape profile would be a result of fabric skew and/or bow, incorrect position of fabric and/or pattern in the layout or on production markers, and inaccurate joined seams etc.

##### **4.8.5.1 Fabric skew and drape**

Skew in woven fabric results when filling yarns are displaced from a line perpendicular to warp yarns expressed in percentage. Fabric skew causes garment twist which subsequently generate different drape shape on each side of the body. Its impact is more obvious on garment drape rather than fabric drape. It could affect garment drape by producing different drape behaviour at the garment edge at each side of the garment (front, back, right and left).

Moore *et al.* studied the most significant factors affecting garment drape negatively. They studied the effect of skew on the drape profile using fabrics supplied with 5 levels of skew (0.2, 1.5, 2.3, 3.3, 4.4). They found that two parameters were sensitive to skew levels which were significantly linear.

These were the asymmetry (at 4.4% skew level) and the distance between adjacent nodes across a seam (at 3.3 and 4.4% skews level). Strong negative correlation was found between shear hysteresis in the weft direction and skew levels with  $R^2 = 0.85$ . They proposed several recommendations for further studies at the end of their paper. These were to increase the number of samples (skirts) from each level of skew than the number they used (3 skirts) and establishing a standard method for mounting the garment tested (skirt) on a mannequin to avoid error in placing the sample (Moore, Gurel and Lentner 1995).

#### **4.8.5.2 Asymmetrical body features(Wearer body)**

Lengthwise and crosswise grain lines of worn garments are ideally perpendicular on and parallel to the floor respectively. Asymmetrical body dimensions (as the ideal body has symmetrical highest and dimension over both sides) could create distortion in garment ideal symmetrical drape due to deforming the grain lines' ideal position. Ready-made garments would not be the proper clothes for these bodies which could be dealt with by custom-made clothes to treat body errors (Moore 1992).

#### **4.8.5.3 Pattern layout and production markers**

Sometimes, garment manufacturers rotate the pattern used in making marker or layout to reduce fabric waste. Laying fabric and/or positioning a pattern on the marker incorrectly could affect garment drape negatively. The pattern cutter must follow the instructions of folding a fabric if it is required to have the grain line of the pattern and the fabric parallel to each other, folds should be done properly to keep this relationship at all layers. Otherwise, the resultant garment would have different drape behaviour over different sides of worn garment (Moore 1992).

#### **4.8.5.4 Sewing operations**

Error in feeding fabric (overfeeding) to the sewing machine due to machine error or operator mistake could affect garment drape. Excess of one side of the sewn garment than the other affected its drape negatively and the shorter side will twist towards its direction (Moore 1992).

#### **4.8.5.5 Unbalanced seams**

Non-identical grain lines of two garment layers which should be identical affects garment drape. The more bias layer will have limited stretchability which consequently causes inconsistent feeding (Moore 1992).

### **4.9 Subjective assessment of drape**

Fabric drape behaviour is one of the garment qualitative attributes/characteristics which is assessed visually by human eye and



depends on fabric properties and surrounding atmospheres. Therefore, it was evaluated subjectively in the textile and apparel industry. Subjective assessments of fabric drape lack reproducibility and often cause controversy due to large variation in evaluators' perception and skill, this shortage ended with development of the quantitative measurement of drape (Behera and Mishra 2006; Kenkare and May-plumlee 2005). Subjective assessment was affected by individual preference, fashion trends (Hearle and Amirbayat 1986) and the length of fabric on the pedestal (sample diameter)(Hu 2004; Zunic-Lojen and Jevsnik 2007). Validation of fabric drape measurement objectively is based on comparing its results/output with subjective results. Subjective assessment of fabric drape behaviour would be carried out by one of three approaches: viewing images of tested fabrics (Uçar *et al.* 2004), displaying real draped samples on a supporting body (Stylios and Powell 2003; Stylios, Powell and Cheng 2002), and handling tested fabrics (Agarwal, Koehl and Perwuelz 2011). The evaluation process was carried out employing paired comparison test within groups of fabrics (Cusick 1965; 1962) or ranking a group of fabrics on a rating scale (Mahar *et al.* 1990).

The first 3D drapemeter was inspired by the way individuals view fabrics. A circular pedestal was used to support and drape the fabric tested. This was similar to draping fabrics shown in the window shops (Chu, Cummings and Teixeira 1950).

Chu and others found good correlation ( $R^2 = 0.78$ ) between drape coefficient measured on an F. R. L. drapemeter and subjective assessment (ranking) carried out by a panel consisting of 57 assessors with different backgrounds in textiles. This meant that that their drapemeter worked efficiently (Chu, Platt and Hamburger 1960).

Cusick in 1962 assessed drape grades of 8 half skirts (semi circular pieces) made from different fabrics using a panel of 5 textile specialists. Fabrics were mounted on mannequins and the paired comparison method was applied. Another test was carried out using photographs instead of using direct views of the half skirts to avoid differences in mounting the fabrics in the previous test and using a higher number of assessors (12 persons). In both tests, it was found that subjective assessment of fabric drape correlated significantly with the drape coefficient values at a level higher than 5%. The subjective assessment showed that there was a relationship between the fashion trend and individuals' evaluation with regard to preference. Subjects preferred stiff fabrics which was the fashion at that time. Drape coefficients presented high positive correlation with each subjective drape amount and preference with  $r = 0.83$  and  $r = 0.81$  respectively. (Cusick 1965; 1962).

Brand proposed that fabric drape would be expressed subjectively through: the way it is perceived by individuals using secondary attributes and polar characteristics (opposite pairs) or objectively using measurements. He

proposed avoiding using “good – bad” expressions in drape assessment. Polar words and attributes such as limp - stiff could be used more efficiently as they were simple words which could be understood easily rather than concept words (Brand 1964).

Ranganathan *et al.*'s dynamic apparatus for measuring fabric drapeability was based on a principle similar to that of average customers' assessment. Customers were used to assess fabric drape while the fabrics were draped vertically downwards generating folds. In their test a fold similar to a real fabric fold was formed (Ranganathan *et al.* 1986).

Mahar *et al.* in 1990 stated that fabric descriptive words called “Fabric handle attributes” such as smooth, soft, full and drape etc., used in the textile and clothing industry were more expressive for fabric than grading them as good/poor. They studied the subjective measurement of fabric handle attributes and quality descriptors. A panel with experience in fabric handle evaluation were asked to evaluate fabric handle on a 6 step rating scale from unsatisfactory to excellent handle. The judges were also asked to rank fabrics tested on a 10 step scale according to intensity of each of six attributes; sleekness, fullness, firmness, warmth, durability, and drape. Japanese standards defining the first three qualities were provided for the judges. Drape had the best correlation with the overall handle ( $r = 0.9$ ), sleekness ( $r = 0.79$ ), fullness ( $r = 0.72$ ) and firmness ( $r = -0.74$ ), warmth ( $r = 0.6$ ) and durability ( $r = -0.1$ ); 35% of the overall handle assessment deviation was due to drape evaluation. However, there were many words used in describing winter suiting fabric handle, a combination of 4 characteristics were useful. These were sleekness, fullness, firmness, and drape. Drape and hardness (anti-drape stiffness) were proposed as opposite attributes to express drapeability which were affected by shear rigidity (Mahar *et al.* 1990).

Collier investigated the validity of objective drape values proposed by Collier *et al.* in 1988 by studying the correlation between them and subjective grades. A subjective assessment process was designed to use a panel consisting of 13 evaluators with expert backgrounds and knowledge of textile and apparel design. The aim of the study was to determine the impact and importance of drape prediction in apparel design. The individuals ranked the fabrics tested on a 7 level scale according to amount of drape and their preference due to the aesthetic drape behaviour. Before the evaluation process the assessors were shown two extreme drape behaviour fabrics on the rating scale. The panel assessment of drape behaviour based on the amount and preference were well correlated at around  $r = 0.9$ ,  $p < 0.0001$ . Both of these subjective assessments correlated strongly with objective drape values measured on a digital drapemeter (of Collier *et al.*) at spearman rank correlation coefficient around  $r = 0.8$ . His study indicated that the preferred drape behaviour was affected by fashion and popular clothes'

style. As highly drapeable fabrics were preferred by the panel which were widely spread (Collier 1991).

Stylios and Zhu defined aesthetic attributes using the natural psychology of consumers. It was found that although the drape coefficient is an important property for the assessment of fabric, it is not an accurate and complete measure of drape since two fabrics can have the same drape coefficient but different drape behaviour. Consequently a number of aesthetic attributes were added to the drape coefficient such as the number of folds, variation of the folds and depth of fold which represent how humans interpret drape aesthetically (Stylios and Zhu 1997).

Orzada *et al.* in 1997 assessed fabric and garment drape using a 7 point Likert scale. Two groups of subjective assessors with two levels of experience of apparel design were asked to carry out the assessment. Fabric drape assessment was conducted using circular fabric samples on a pedestal according to drape amount and preference. However, 12 skirts with different tilt combinations for the front and back sides were hung on a mannequin for the assessment of garment drape. Skirt evaluation was carried out according to drape amount, preference for purchase, and accuracy of pattern layout (visual and close up with touch). These four aspects of assessment were averaged for each skirt and their score converted into ranks. Drape was defined and two extreme samples with regard to drape amount were shown to the judges prior to the test.

In the fabric test, drape amount and preference of most of the fabrics tested showed significant positive correlations ( $r > 0.6$ ). The more experienced individuals rated the fabrics at lower levels and exhibited higher preference consistency than the less experienced did. However, drape amount assessment by the two groups showed higher similarity than preference evaluation. However, the more experienced group had stronger correlation with objective values of drape with regard to drape amount than the less experienced. Drape amount was correlated higher than drape preference with the 8 fabric properties measured. In the garment test, 12 skirts were ranked by the researcher according to the tilt degree combination. Advanced judges had higher agreement between themselves and with the researcher's rank and sensitivity than less experienced individuals (Orzada, Moore and Collier 1997).

Uçar *et al.* evaluated 30 fabrics' drapeability subjectively using images captured for the correspondent fabrics. Five assessors (with textile ranking and rating background) viewed the images and ranked them according to drape amount and after that were rated on a 10 step scale, with 1 being the highest drapeability. Subjective drape ratings were highly correlated with theoretical drape ratings resulting from their developed equations including drape coefficient and number of nodes as independent variables ( $r = 0.86$ )

which was higher than its correlation with rating equation using drape coefficient only (Uçar *et al.* 2004).

Shyr *et al.* carried out subjective evaluation for the number of nodes of pure wool fabrics using photos for measured fabrics and the results were used as a basis for developing an equation for objective assessment of number of nodes. The assessment started with 19 individuals with a background in textiles and fabrics. Inconsistent evaluators (whose number of nodes showed high variance within the results) were removed from the results and the subjective assessment was proved by the 13 assessors whose results were highly consistent (Shyr, Wang and Lin 2009).

Agarwal *et al.* asked 6 individuals to rank 52 knitted fabrics according to their drapeability using the two paired comparison technique to rank them from 1 to 52. They were asked to handle the fabrics by laying them on the back of their hands. They established the relation between measured mechanical properties (tensile, shear and bending) and a drape grade resulting from the subjective assessment using Equation 4.5.

$$T_{YZ} = \frac{2 \sum_{i \neq j} t_{YZ}(i, j)}{q(q-1)} \quad 4.5$$

where:  $t_{YZ}(i, j) = \frac{|Y_i - Y_j|}{|Z_i - Z_j|} + \frac{|Z_i - Z_j|}{|Y_i - Y_j|}$ , where  $Y_i$  and  $Y_j$  denote the normalised value of the mechanical parameter for the  $i$ th and  $j$ th samples, respectively,  $Z_i$  and  $Z_j$  denote the normalised sensory score for the relevant attribute and  $q$  was the total number of samples. The smaller the  $T_{YZ}$  parameter was, the higher the agreement between the subjective ranking and mechanical properties. The best correlation was between shear rigidity  $G$  and bending hysteresis 2HB and drape grade (Agarwal, Koehl and Perwuelz 2011).

#### 4.10 Prediction of drape coefficient

Assessment of fabric drape has been investigated theoretically for a long time by researchers in the textile area as using equations was easier, less tedious and quicker than carrying out experiments. As it takes a long time and several steps have to be done to obtain fabric drape values (static or dynamic) even by image analysis techniques or cut and weigh conventional methods. Moreover, prediction of fabric drape was important in the development/improvement of textile products characteristics (Robson and Long 2000). Most equations include independent variables; namely fabric physical and the mechanical properties were used to calculate the fabric drape coefficient.

Cusick in 1965 studied theoretically the relationship between fabric drape coefficient, bending length and shear stiffness. Simple and multiple

regression analyses were applied to investigate this relation for 130 fabrics. Regression of drape coefficient on bending length ( $c$ ), shear rigidity( $A$ ) and combinations of them were calculated and produced 7 regression equations. The model included a combination of 4 variables  $c$ ,  $c^2$ ,  $A$  and  $A^2$  which had the lowest residual value which means that it was the best one fitted to the data (experimental values) (see Equation4.6).

$$DC = 35.6c - 3.6c^2 - 2.59A + 0.0461A^2 + 17 \quad 4.6$$

Cusick also studied in his paper the theoretical relation between the drape coefficient and bending length and neglected the shear rigidity. Because of the obviation of the shear rigidity, the experimental drape coefficient values were higher than the theoretical values and that was shown when both observed and theoretical values were plotted on one graph (Cusick 1965).

Gaucher *et al.* used multiple regression analysis to predict knitted fabric drape coefficient using physical and mechanical properties. It was found that bending length is the best predictor for all knits. *BL* had good prediction level when it was combined in best equations with: thickness and shear properties in the overall group, thickness and extensibility in the warp knitted subgroup and only with shear in the weft knitted subgroup. It was observed that using a mechanical property value of different face, direction or average resulted in prediction equations with different reliability degrees. In other words, the overall mean did not always exist in the best predictive equation (Gaucher, King and Johnston 1983).

Postle and Postle proposed using a static cantilever bending length differential equation in modelling fabric buckling including drape (Postle and Postle 1993). This indicates the importance of the bending length contribution to drape profile.

Hu and Chan employed stepwise regression analysis using four different models to find the best basic parameters combination to predict drape coefficient theoretically. Only one parameter from each interrelated (blocked) mechanical properties group correlated strongly with each other and highly correlated with drape coefficient was used in establishing predictive equations. Equation 4.7 produced the best regression coefficients and residual values using values of 2HB,  $G$ , LT and MMD ( $BR$  could replace 2HB).

$$\ln DC = b_0 + \sum_{i=1}^n b_i \ln x_i \quad 4.7$$

where: DC was the Drape coefficient,  $b_0$  and  $b_i$  were arbitrary constants,  $n$  was the number of parameters closely related to the Drape Coefficient,  $n$  ( $1 < n < 16$ ),  $x_i$  represented a mechanical property parameter, which means

that these were the most important predictors for the drape coefficient (Hu and Chan 1998).

Postle and Postle pointed to the possibility using mathematics for modelling fabric deformation and described fabric surface using differential geometry parameters such as curvature. Mathematically, its deformation could be expressed by its transformation as invariants and exhibited the inherent properties of the fabric (Postle and Postle 2000).

Lo *et al.* developed a model for predicting fabric drape profile. This model was established using the trigonometric Equation 4.8.

$$r = p + q \sin(k\theta + \alpha) \quad 4.8$$

where:  $r$  was the radius of the projected drape profile,  $p$  was the mean of radial length between peaks and troughs,  $q$  was half-depth of node,  $k$  was the number of nodes,  $\alpha$  was a constant representing an angle between the fabric main direction and its adjacent peak. The constants  $p$ ,  $q$  and  $k$  were calculated using the polar coordinate fitting technique to obtain a theoretical drape profile. This process included providing computer software with the experimental results of  $(r, \theta)$ , where,  $r$  was the radial length of the drape profile at  $7.5^\circ\theta$  interval from  $0^\circ$  to  $352.5^\circ$ , to obtain the constants. Moreover, the drape coefficient, node number and location for each specimen were produced (calculated). Theoretical and experimental drape profiles and values showed good correlation which means that the developed model was valid to predict those values.

They also studied the availability of calculating these constants  $p$ ,  $q$  and  $k$  using the mechanical properties measured on KES - F. Stepwise regression analysis of constants on the bending and shear hysteresis properties produced equations which were used efficiently to calculate the constants of their developed models. Strong correlations were found between constants and the mechanical properties used. The average mechanical properties of warp, weft and bias direction (45 and 135 from the warp) produced higher correlation with the constants than using the mean of warp and weft only (Lo, Hu and Li 2002).

Stylios and Powell studied the engineering of the drapeability of textile fabrics using neural networks. In their system the relations between fabric: mechanical properties, drape values (drape coefficient, fold depth, number of nodes and evenness), drape grade (from subjective evaluation) and its end-use were established. This system was successfully used in forward (prediction of drape grades and end use employing fabric mechanical properties) and backward (using a feedback system to adjust the drape behaviour of a product by modifying the fabric mechanical properties) predictions. This model predicted the drape grades of 90% of the samples

and was claimed to be better than the traditional predictive techniques (namely; regression and discriminate analysis) (Stylios and Powell 2003).

Uçar *et al.* developed a prediction equation for the drape coefficient of seamed heavy weight knit fabrics using a regression analysis method (see Equation 4.9).

$$DC_1 = 18.5 + (0.65 DC_0) + 0.889 NS \quad 4.9$$

where:  $DC_1$  was the drape coefficient of seamed fabric,  $DC_0$  was the drape coefficient of seamless fabrics, NS was the number of seams on the sample. This theoretical DC exhibited high correlation with experimental DC with  $r = 0.8$ . Equations 4.10 and 4.11 were developed for prediction of fabric rating with regard to their drapeability degree.

$$R_1 = -28.5 + (0.61 DC) \quad 4.10$$

$$R_2 = -7.86 + (0.39 DC) - (1.27N) \quad 4.11$$

where:  $R_1$  and  $R_2$  were the ratings, DC the drape coefficient, N the number of nodes. The second equation produced higher correlation with the subjective rating than the first one which included only the drape coefficient value (Uçar *et al.* 2004).

Yang and Matsudaira (between 1998 and 2001) developed regression equations to predict fabric drape theoretically, namely: Static drape coefficient ( $D_s$ ), revolving drape increase coefficient ( $D_r$ ), dynamic drape coefficient ( $D_d$ ), Dynamic drape coefficient at 200 r.p.m ( $D_{200}$ ) and dynamic drape coefficient with swinging motion  $D_{sm}$ . These equations were applied in several further studies investigating drape in terms of studying different features of fabrics (Matsudaira and Yang 2003b; Matsudaira *et al.* 2002; Tandon and Matsudaira 2010; Shyr, Wang and Cheng 2007; Matsudaira and Yang 2000) and the effect of finishing on fabric drape behaviour (Matsudaira *et al.* 2003; Matsudaira and Yang 2003a).

Static drape coefficient  $D_s$  and node number  $n$  were calculated using Equations 4.12 and 4.13 respectively.

$$D_s = \frac{4a^2 + 2b^2 + 2a_m^2 + b_m^2 - 4R_0^2}{12R_0^2}, \quad 4.12$$

$$n = 12.797 - 269.9 \sqrt[3]{\frac{B}{W}} + 38060 \frac{B}{W} - 2.67 \frac{G}{W} + 13.03 \sqrt{\frac{2HG}{W}} \quad 4.13$$

where:  $R_0$  was the radius of a circular supporting stand (63.5 mm),  $a$  was a constant showing the total size of the two-dimensionally projected area (mm),  $b$  was a constant showing the height (amplitude) of a cosine wave of the two-dimensionally projected shape (mm),  $a_m$  and  $b_m$  were constants present the anisotropy of fabrics. These constants were calculated using

mechanical parameters measured by the KES system using the Equations 4.14 - 4.17.

$$a = 35.981 + 1519 \sqrt[3]{\frac{B}{W}} - 204300 \frac{B}{W} + 23.27 \sqrt[3]{\frac{G}{W}} + 0.0178G \quad 4.14$$

$$b = 29.834 - 1.945n - 0.0188G - 91.84 \frac{2HG}{W} \quad 4.15$$

$$a_m = 9063 - \left(\frac{B_1 - B_2}{W}\right)^{2/3} \quad 4.16$$

$$b_m = 6224 - \left(\frac{B_1 - B_2}{W}\right)^{2/3} \quad 4.17$$

where: B=bending rigidity (mN.m<sup>2</sup>/m), G = shearing rigidity (N/m/rad), 2HG=hysteresis in shearing force at 0.0087 radians (N/m), W=fabric weight (mg/cm<sup>2</sup>); B1, B2=bending rigidity in the warp and weft directions respectively.

The revolving drape increase coefficient  $D_r$  (the slope of the curve of correlation between revolving drape coefficient with revolutions in the range between 50-130 rpm) was calculated using Equation 4.18.

$$D_r = 0.792 + 2.374 \sqrt{\frac{2HG}{W}} - 0.6305 \sqrt[3]{\frac{G}{W}} - 6.762 \sqrt[3]{\frac{B}{W}} - 2.673 \frac{2HG}{W} + 0.0005W \quad 4.18$$

The dynamic drape coefficient at 200 rpm,  $D_{200}$ , was calculated using Equation 4.19.

$$D_{200} = 61.475 - 37.02 \frac{G}{W} + 0.1411G + 40.88 \sqrt[3]{\frac{G}{W}} + 0.049W + 436.8 \frac{2HB}{W} \quad 4.19$$

where: 2HB is the hysteresis in bending moment at 0.5 cm<sup>-1</sup> (mN·m/m).

Gider derived equation for predicting the drape coefficient using mechanical properties measured on KES-F. Stepwise regression analysis produced Equation 4.20.

$$DC = 69.17 + 25.51(2HB) - 35.69MIU + 3.50G + 0.00049RT + 21.13WC - 0.492RC - 13.04t + 0.303EMC + 0.51W \quad 4.20$$

where: 2HB was bending hysteresis, MIU was mean frictional coefficient, G was shearing stiffness, RT was the tensile resilience, WC was the compressional energy, RC was the compressional resilience, t was the fabric thickness EMC was the compression rate, W was the weight.

He also developed an online database search engine to help select fabrics for certain end-uses with intended mechanical properties and drape



especially. This system predicted drape coefficient with 94% accuracy compared with measured values (Gider 2004).

Lam *et al.* used drape coefficient and circularity as drape parameters in neural networks used to predict fabric drape. In the proposed model, 7 mechanical properties showed strong correlations with fabric drape. These were weight, thickness, bending rigidity, shear rigidity, hysteresis of shear force at 0.5 degree, linearity of load-extension curve, and weave. Their model was comprehensive in predicting the output data and the difference between desired and resulting outputs. This system worked efficiently, however they pointed to the key to improving this model which was to establish a huge data base with input and output data (Lam, Raheja and Govindaraj 2004).

Jeddah *et al.* investigated the prediction of drape coefficient using two alternative theoretical models: Regression and neural models. Bending and shear stiffness were the best predictors for the drape coefficient followed by the thickness. Predicted and measured DC were highly and strongly correlated, however, the neural model (with error 2.7%) had higher accuracy than the regression models (error 3.9%). Fabric structure had no effect on the correlation between the measured mechanical properties and the DC, however twill fabrics had higher correlation than plain fabrics (Jedda, Ghith and Sakli 2007).

Agarwal *et al.* modelled a fuzzy logic system to predict drape grade. They used shear rigidity ( $G$ ) and hysteresis in bending moment (2HB) as inputs because they had the best correlation with subjective assessments (Agarwal, Koehl and Perwuelz 2011).

#### **4.11 Drape simulation**

Since the mid-eighties, researchers have been developing alternative numerical techniques for simulating the draping process for fabrics and garments (Chen, Hu and Teng 2001; Chen and Govindaraj 1995; Stump and Fraser 1996; West, Pipes and Keefe 1990; Potluri, Sharma and Ramgulam 2001; Mccartney *et al.* 2000; Collier *et al.* 1991; Yu, Kang and Chung 2000; Pandurangan *et al.* 2008; Kenkare *et al.* 2008; Lo, Hu and Li 2002; Stylios, Wan and Powell 1995; Hu, Chen and Teng 2000; Fischer *et al.* 1999; Hwan Sul *et al.* 2006; Stylios and Wan 1999; Bendali, Koko and Quilliot 1999; Postle and Postle 1999; Stylios and Wan 1997; Gan, Ly and Steven 1995). Prediction and simulation of fabric and garment drape allowed drape researchers to know how fabric properties affected drape shape rather than comparing between drape coefficients of different fabrics. Different combinations of fabric mechanical properties were used as input data to obtain a drape model shape (Stylios and Wan 1997).

Ngoc and Anh used pictures captured from front, back and side views for skirts worn by a mannequin to obtain virtual simulation for them using 3D simulation software (V- Stitcher 4.3). They found similarity between actual and virtual skirts; however the first had bigger and deeper folds than the second (Ngoc and Anh 2008).

The importance of accurate fabric drape simulation (3D presentation), and methods and technologies used to accomplish this would be reflected in computer graphics (fabric representation) and the textile and apparel industries (Collier and Collier 1990).

In computer graphics, the generation of satisfactory simulated/virtual output could improve this industry and satisfy users, manufacturers and designers. Workers in the apparel industry (including: design, product development and manufacturing) would be able to simulate, quantify and compare the drape of apparel virtually, consequently producing improved products with high success rates; reduced quantities of incorrect prototype products and enhanced business processes.

In design and product optimisation and development areas, it is becoming more difficult to depend on specialists' experience to evaluate and predict the drape behaviour of fabrics with the increasing number of new fibres, yarns and fabrics with different properties (Kenkare 2005). This makes predicting and modelling fabric appearance, including drape prediction, highly important for end product aesthetics and manufacturing. Virtual 3D modelling would be at the base of producing improved accuracy, efficient and quick clothing Computer Aided Design (CAD) systems as CAD software users always expect accurate and rapid fabric drape simulation (Chen, Hu and Teng 2001; Stylios, Wan and Powell 1995). CAD systems provide designers with virtual environments by which they can view their designed garment before making it which guides them to the appropriateness of a fabric and garment fit (Hardaker and Fozzard 1998).

Moreover, researchers proposed using dynamic fabric simulation as a way of coping with low sales of fabric products due to design and/or style faults. The designer could visualise his design using the proposed fabric which would give him a reliable 3D presentation before production which make designers abandon making prototypes. Development of products using conventional methods is time and resource consuming, however employing simulation methods for visualising developed garment saves time and cost (Kenkare 2005). It was supposed that this system could be used by designers and technologists to develop their new materials (fabrics) by the process of reverse engineering (Stylios and Wan 1999).

In communication within the textile and apparel industry, simulation of fabric and garment drape could allow different departments or organisations to

exchange and share viewing draped garment which would enhance apparel design, manufacture and management.

E-commerce is increasingly being used all over the world. However, the percentage of sold apparel online is very low compared to apparel is being sold with the conventional methods and other goods such as books are being sold online. Accurate product characterisation is one of the factors which causes this small portion of selling apparel online (Kenkare 2005). Therefore, improving virtual simulation of fabric drape could affect the global retailing systems and enhance competitiveness in the textile and apparel market over the world (Stylios and Wan 1999).

From this review the importance of the input data to achieve the best visualisation of fabric drape is obvious. Therefore working on revealing the combination of fabric properties which would be used as input data for this simulation is essential.

#### **4.12 Summary**

Fibre and fabric physical properties affecting fabric drape have been investigated by different researchers. Fibre fineness was found to generally improve fabric drapeability (Werner and James 1952). Fibre cross sectional morphology and moment of inertia had an impact on fabric drapeability (Chu, Platt and Hamburger 1960) and increased space ratio increased fabric drapeability (Matsudaira, Tan and Kondo 1993). Yarn characteristics had also an effect on fabric drape behaviour (Backer 1948). Increased yarn diameter decreased drapeability (Chu, Platt and Hamburger 1960). However, yarn count in another study had a contradictory effect on different fabrics (between increasing and decreasing drapeability) (Matsudairaa, Yamazaki and Hayashi 2008). Yarn count and density had more impact on drape than fibre cross sectional shape (Matsudaira, Tan and Kondo 1993). Yarn interaction in terms of shear rigidity had more impact on drape than *BR* (Jeong and Phillips 1998).

With regard to fabric construction, increased yarn floats increased drapeability (Chu, Platt and Hamburger 1960). However in another investigation Basket twill fabrics (with longer floats and fewer interlacings than broken twill) had lower drapeability than broken twill (Quirk, Martin and Jones 2009). Increased cover factor decreased drapeability (Chu, Platt and Hamburger 1960) and increase its instability (Jeong and Phillips 1998). Higher weave crimp and tightness was found to decrease fabric drape (Jeong and Phillips 1998). Skew weaves produced high drape coefficient (Frydrych, Dziworska and Cieslinska 2000). Fabrics with similar warp and weft twist (Z) directions had less drapeability than fabrics with different warp and weft twist directions (Z and S respectively) (Al-Gaadi, Göktepe and Halász 2011).

The relation between fabric drape and handle was found to be poor (Howorth and Oliver 1958) and strong (Elder *et al.* 1984; Kim and Slaten 1999).

Fabric anisotropy behaviour had an impact on its drapeability. In terms of the relation between *BR* of warp and weft directions, when the warp direction had higher *BR*, drape profile was oriented vertically. If weft *BR* was higher, drape profile was oriented horizontally, however when they were similar the drape profile exhibited the lowest level of anisotropy (Sidabraitė and Masteikaitė 2003). As anisotropy degree increased, the difference between warp and weft *BR* generated clear stable and good node arrangement in the drape profile (Hu, Chung and Lo 1997).

Relationships between fabric drape and mechanical properties were investigated. It was found that the following properties correlated with drape: Bending properties (Shyr, Wang and Cheng 2007) including bending length (Chu, Platt and Hamburger 1960), bending rigidity (Pierce method) (Collier 1991; Behera and Pattanayak 2008) bending modulus (Collier 1991) and bending hysteresis (pure bending tester) (Collier 1991), shear properties (Shyr, Wang and Cheng 2007) including shear rigidity (Cusick 1965) (Kawabata tensile and shear tester) (Collier 1991; Behera and Pattanayak 2008), shear hysteresis (Kawabata tensile and shear tester) (Collier 1991), residual bending curvature and residual of shear angle (Jeong and Phillips 1998), extensibility at 45° (Okur and Gihan 1993) and at low loads (Behera and Pattanayak 2008), formability (*BR/ITM*) (Frydrych, Dziworska and Cieslinska 2000), fabric liveliness (Brand 1964), friction properties including static friction coefficient (Kim and Slaten 1999), kinetic coefficient friction (Kim and Slaten 1999), surface friction (Tandon and Matsudaira 2010), roughness (Kim and Slaten 1999), tensile properties including tensile behaviour (Tandon and Matsudaira 2010), initial tensile modulus (Frydrych, Dziworska and Cieslinska 2000), tensile energy (analogous to initial modulus) (Behera and Pattanayak 2008). Compressional properties (Behera and Pattanayak 2008) including thickness had different relations with drape between inexistent (Collier 1991), existent effect (Tandon and Matsudaira 2010) and improving stability of drape profile (with increasing thickness) (Kim and Slaten 1999, Hu, Chung and Lo 1997) (Hu, Chung and Lo 1997).

Fabric weight as well had different effects on drapeability between inexistent (Collier 1991), existent (Tandon and Matsudaira 2010), positive (Frydrych, Dziworska and Cieslinska 2000) (Kim and Slaten 1999) and negative relations (Uçar *et al.* 2004) effects.

With regard to fabric finishing treatment, chemical relaxation treatment increased fabric drapeability (Collier 1991). Weight reduction was found to increase drapeability (Matsudaira and Yang 2003a). Washer relaxation effect was stronger than the jet machine relaxation in decreasing the drape

coefficient (Matsudaira *et al.* 2003). Dyeing and raising processes did not affect fabric drapeability (Matsudaira *et al.* 2003). Using a softener in a washing process and wash ageing (20 th washing) improved drapeability (Agarwal, Koehl and Perwuelz 2011).

In test procedures, it was found that the lower the contact between the operator and the sample tested in the mounting procedure, the higher the reproducibility of drape test (Morooka and Niwa 1976). A small diameter supporting disc increased drapeability and reproducibility of drape values (Cusick 1962).

It was found that drape coefficient decreased with time (Cusick 1965) and reached a stable state at minute 7 (Jeong 1998).

Comparison between drape parameters measured using fabrics and garments confirmed that garment drape was not predicted precisely using the fabric drape parameters (Ng, Hui and Tam 2002). This is important as the author of this thesis agrees with this.

Drape coefficient increased with the number of layers and width in circular samples and with bonded circular edges in circular samples (Hu, Chung and Lo 1997). Factors which dominated the effect of interlinings on composite fabric shear stiffness were the interconnection density (stitching or fusing) and the shear rigidity ratio of interfacing to the shell fabric used (Collier, Paulins and Collier 1989).

The addition of seams increased fabric DC (Jevšnik and Žunič-Lojen 2007). Increased seam allowance reduced fabric drapeability and large nodes were generated along the seam (Hu, Chung and Lo 1997, Uçar *et al.* 2004). Radial Seam number increased fabric DC, this effect was more obvious with increased seam number (Uçar *et al.* 2004). Seaming swung the highest node to the seamed part, while seamed parts stabilised the nodes at it. The more seams added to a fabric, the more stable the drape profile and NN was. Number of seams showed great effect on the drape profile of heavyweight fabrics, but very little effect on lightweight fabrics (Hu and Chung 1998). The higher the localised fabric weight generated due to a pressing SA in one direction, the lower the drapeability of the fabric was (Chung, Hu and Lo 1997). If seamed fabric became triple layered, the addition of extra stitches or layers did not have a significant effect (Sharma *et al.* 2005).

Fabric skew, asymmetrical body, tilted grain line and unbalanced seams could deform garment drape (Moore 1992).

In subjective assessment of fabric drape, evaluation would be carried out by viewing their photos or by draping them in front of assessors (Cusick 1965; 1962).

This review shows that extensive research has been carried out by many researchers over most of the twentieth century. Many findings are consistent with each other but some contradict or conflict with each other. There has not been a lot of research on nonwoven fabrics yet, this is probably because the interest in using nonwoven fabrics in fashion apparel has only been increasing over the last decade. Therefore this current research is aimed at this area. Also, there seems to have been an increasing opinion that the measurement of flat fabric parameters does not enable the accurate measurement of the many parameters which influence garment drape both subjectively and objectively.

## **Chapter 5**

### **Nonwoven fabrics**

#### **5.1 Introduction**

The term “Nonwoven” is used in the textile manufacturing industry to mark or specify fabrics that are neither woven nor knitted. Nonwoven fabric is a sheet or web of directionally or randomly oriented fibres or filaments bonded by friction and/or cohesion and/or adhesion using mechanical, thermal and/or chemical processes (EDANA 2012b; INDA 2012a).

Nonwovens are unique, innovative, versatile and high-tech; engineered fabrics made of fibres. They are necessary in our modern life because of their different applications and products (INDA 2012a). They could be engineered to be single use, limited life or durable according to the end use product (fit for purpose). The reproduction of conventional fabrics' (woven and knitted) visual, physical and mechanical properties is one of the nonwoven technology objectives.

Nonwoven fabrics are made of different fibres using different processes, and bonding agents. Their characteristics are affected by the selection of each of them and the classification could be based on fibre type, web formation/consolidation process, bonding and technological methods of manufacture. However, classification by method/process of production is the most common (Krcma 1971; Purdy 1985). Nonwovens are best classified by process (web formation and bonding) as each one is capable of producing fabrics with unique features from similar and different fibres (Hutten 2007).

#### **5.2 Manufacturing processes**

Nonwovens manufacture includes three main stages: web formation; web bonding and finishing treatments. There is a possible overlap between them or sometimes the three stages are combined.

##### **5.2.1 Web formation**

This process includes converting the fibres or the filaments from the fibrous form into a 2D (web) or 3D web assembly (batt) by depositing or condensing them onto a forming surface. During this process, the fibre direction which subsequently affects the fabric isotropy properties is determined (most nonwoven fabrics are anisotropic). Web mass (weight), thickness and surface uniformity determine the final fabric properties. Moreover, the technique of production and fibre properties influence them. Fibre orientation in a web or fabric is identified by the ratio MD (Machine

direction) to CD (Cross direction) (Krcma 1971; Russell 2007). Machine direction: cross direction (MD : CD) is the ratio calculated to measure the fibre orientation in a web or fabric (more usually). This ratio is an indicator of the measured fabric tensile strength. It is rare and unnecessary to commercially produce a fabric with MD : CD = 1 (perfect isotropic structure). Mostly, each web formation system is used to process certain fibre types, however similar commercial products engineered by different systems do exist. There are three main types of this process; these are dry, wet or polymer laying (Russell 2007).

### **5.2.1.1 Dry laying**

In this method fibres are manipulated in the dry state. There are two methods of dry laying: carding and air laying (aero dynamic). The carding process used resembles the one used in the traditional spinning process. Parallel laid webs can be produced with good tensile strength, low elongation and tear strength in the machine direction where most of the fibres are oriented. However, the processing of very short fibres is better by the air laid technique (Holliday 1993; Russell 2007; Rupp 2008a). In this method, the air is used as a dispersing medium and transfers fibres to the web forming platform (moving belt or perforated drum) to form a randomly oriented web.

Air laid webs, compared to carded webs, have low density, better softness, an absence of laminar structure and a wider range of processable fibres (Rupp 2008a).

The web produced in dry laid methods is bonded later using mechanical (needlepunched, hydroentangled, or stitch bonded), chemical or thermal methods. This type of nonwovens dominates a large amount of the nonwovens market (Russell 2007; Rupp 2008a).

There are three main types of nonwoven web made from staple fibres according to fibre orientation direction. These are parallel-laid, cross-laid and random-laid. In parallel laid webs, the fibres are oriented in the fabric lengthwise direction. They have lower strength in the crosswise direction than the longitudinal direction (because of high friction between the fibres) and have highly anisotropic mechanical properties. Cross-laid webs are produced by superimposing at least two parallel laid (oriented in long and cross direction) webs on top of each other or the fibres making up the web are orientated equally in both lengthwise and crosswise directions. These webs have good strength in both main directions but are still anisotropic. They are created by blowing the fibres in a stream of air and then sucking them onto the surface of a perforated drum to form a layer. In the random webs, fibres are oriented randomly. These webs are highly isotropic (uniform). The degree of fibre orientation can be manipulated by a further process such as stretching. The choice of the laying method is dependent



on the required strength, tendency to delamination, tear – resistance and cost (Cusick *et al.* 1963; Blackley 1997).

### **5.2.1.2 Wet laying**

This method's origin is the paper making process. The manufacture of the web depends on using machines designed especially to handle short fibres and suspend them in a liquid. In this process, the web is formed from fibres deposited on a moving perforated platform in water. Then, the web is dewatered, consolidated and dried (EDANA 2012b).

A limited number of companies employ this process due to its high rates of water utilisation. Wet laid nonwovens and paper are discriminated according to EDANA by the following factors, if the ratio of fibre length to diameter of 50% of the fibres is higher than 300 and/or 30% of fibre density is less than  $0.4 \text{ gm/cm}^3$  (excluding most wet laid glass fibre structures) the fabric is considered nonwovens (Russell 2007).

### **5.2.1.3 Polymer laying**

This type of nonwovens is also called spunmelt nonwovens. The development of this technology was inspired by the extruding machines used in spinning. In the basic production process, molten polymer is extruded into synthetic sheets of filaments on a conveyor. As this method of manufacturing nonwovens reduces the intermediate processes of producing fabrics, it has the advantages of high production rate and reduced cost (Russell 2007). There are two main processes used with similar principles but different technologies, these are spunbonding and meltblowing.

Thermoplastic high molecular weight polymers such as polypropylene, polyester or polyamide are used in the production process. Polypropylene availability around the world, low cost with good value and ease of use compared to polyester and polyamides made it dominate the nonwoven production using spunlaid and meltblown methods.

In the spunbonded/spunlaid process, polymer granules are melted and extruded through spinnerets to make continuous filaments which are subsequently deposited on to a conveyor to make a web. The remaining temperature would cause adherence of the filaments and would be considered as a bonding process but it does not have significant impact. These type of nonwovens are characterised by high strength, limited flexibility and low weight. Moreover they have a quite high air permeability, use no chemicals, are thermobonded, and have a very good bidirectional machine direction/cross direction, and wear properties. Modern spunbonds are soft and comfortable, and the average weight today is from 10 to 150 grams per square metre (EDANA 2012b).

The meltblown web is formed by subjecting the extruded polymers to high velocity airstream, so the melt is scattered, solidified and breaks to form a web (EDANA 2012b; Rupp 2008b).

Spunbonded and meltblown webs are different in that the meltblown web contains staple fibres rather than continuous filaments which results in ease of operation. Moreover the meltblown webs have much finer fibre diameter which produces fabrics with better softness, drapeability, and opacity (Newton and Ford 1973).

Two approaches are used, combined or separately, in manufacturing spunlaid nonwovens to obtain fabrics with a textile appearance. The first of these is developing a helical crimp of bicomponent (side-by-side or eccentric sheath-core) fibres during quenching and stretching in the extrusion process followed by a thermal treatment, and the second is producing microfibre during the hydroentanglement process (following the spunbonding process) using splittable bicomponent fibres (Russell, Beverley and Saleh 2006).

Some spunbonded fabrics are made of different polymers. Splittable bicomponent filaments are used in these fabrics. In these fabrics, the filament cross section has at least two polymer components which are arranged sequentially in a segmented pie during the spunbonding process. Bicomponent fibres have been employed in the manufacturing of nonwovens to produce fabrics with properties not achievable by single component fibres using various techniques including mechanical, thermal, and chemical methods. Fabric properties and performance are dependent on the method used.

Spunbonded fabrics are characterised by two groups of properties affecting fibre diameter, web structure, physical and tactile properties. These are material and operational variables. The first includes polymer type, molecular weight, molecular weight distribution, polymer additives, polymer degradation and polymer form. The second is subdivided into two subgroups of on and off line variables. The on-line variables could be changed according to the product characteristics such as polymer throughput, temperature, quench air rate and temperature, take up speed and bonding conditions. However, the off-line variables are the factors that could be changed when the production line is out of operation for instance spinneret hole size, spinneret –collector distance each product line has its own off line features.

Moreover, filament properties including linear density, tenacity, elongation, modulus, cross section, crimp and morphology, filament arrangement including filament separation, fabric weight uniformity, random versus directional, and bonding variables including binder nature, binder

concentration and binder distribution determine spunbonded fabric properties.

The most common filament linear density is between 1.5-20 dtex. Fabric weight ranges between 10 and 800 g/m<sup>2</sup> which is determined by its thickness, filament denier and number of filaments/units.

Polymer type affects basic properties such as filament density, temperature resistance, chemical and light stability etc. However, the method of manufacture affects fabric geometry.

Due to the random lay down of the filaments, the webs have near planar-isotropic properties. However, the degree of anisotropy is controlled by the filaments' orientation during web formation. Commercial spunbonded fabrics are anisotropic with preferred orientation in the machine direction because the filaments are deposited on a high speed conveyor.

Spunbonded webs are characterised by a near fibrous structure, white with high opacity, high strength to weight ratios (compared to other nonwoven and conventional fabrics, resistance to fray and crease, low drapeability (Russell 2007).

## **5.2.2 Web bonding**

This is the stage of setting bonds between the web fibres. It could be carried out separately after the web formation, but it is mostly conducted in line with it. A combination of web bonding methods could be applied on one fabric. This stage affects the final fabric mechanical properties such as strength, porosity, flexibility, softness and density. It includes three main methods chemical, thermal and mechanical bonding.

### **5.2.2.1 Chemical (adhesion) bonding**

This method is based on setting bonds between the fibres by adding a non-fibrous (adhesive) binder substance to the web using uniform techniques such as impregnating or spraying or sporadic techniques such printing. Printing techniques are applied when predesigned pattern of a fabric is required and to control the amount of fibres binder free. Mostly, liquid based bonding agents are used as binders however the water based binders are widely used. Powdered adhesives, foam and organic solvents are used as well. Then, the web is exposed to a high temperature to dry, cure and fuse the binder. This type of nonwoven compared to other nonwovens is stiff and has high tensile strength and resilience (Rupp 2008).

### **5.2.2.2 Thermal (cohesion) bonding**

This method of bonding exploits the thermoplastic properties of man-made fibres to establish bonds between fibres using heat. This is the use of heat (and often pressure) to fuse or weld fibres together without melting them.

Fibres are entangled using the existing adhesive substances or agents. The bonding agent is a fibrous component but most often it is low-melt polyethylene or bicomponent fibre. Sometimes, it helps to dispense the binders as fibrous material or dry powder. The advantages of this method are related to: its low energy consumption and the high production rate. Moreover, being eco friendly products is one of the benefits (Hegde, Bhat and Campbell 2008; Lyukshinova, Kurdenkova and Shustov 2008)

In this process, applying both pressure and temperature to the web with a calendar develops the fibre entanglement. Bonds in the web require polymer chain melting and diffusion (Hegde, Bhat and Campbell 2008).

Thermal bonding systems include: calendaring, through-air, drum and blanket and sonic bonding applications. Rollers are used in the calendaring process to weld fibre webs using heat and pressure. Bulky webs are better bonded using a stream of hot air in through-air systems. However, average bulk products are bonded using drum and blanket systems using heat and pressure. In sonic bonding, a web is bonded using stimulateable fibre molecules using high frequency energy producing heat energy (Russell 2007).

One thermobonding technique was developed as a result of advances in laser technology. The laser technique is used for the production of spot-bonded acrylic- and poly ester-fibre nonwoven structures. Fabric properties, such as breaking strength, handle, and heat-insulating characteristics, are found to be superior to those of other nonwoven fabrics(Purdy 1983).

### **5.2.2.3 Mechanical (friction) bonding**

Stitchbonding, Needlepunching and Hydroentangling are different available types of mechanical bonding by which fibres web are physically entangled through inter-fibre friction.

Stitch bonded fabric is a fabric produced by holding fibres, yarns, fibres and yarns, or fibres and a ground fabric together using subsequent stitching or knitting in of additional yarns (Russell 2007).

Needle punching is the major process for producing mechanically bonded nonwoven fabrics from fibrous webs. This is the process of converting a web of fibres into a coherent fabric structure, normally by means of barbed needles (pushed and pulled through the web), which produce mechanical bonds within the web (Purdy 1980) .

#### **5.2.2.3.1 Hydroentangled nonwovens**

Hydro entangling, spun lacing, hydraulic entanglement and water jet needling are synonyms for the term “Hydro entanglement”.

#### 5.2.2.3.2 Principle and entanglement mechanism

This is the process of mechanically bonding and intertwines neighbouring fibres due to high velocity water jets which produce water agitation in the web.

In this process, water is pumped through nozzles to produce multiple high-pressure columnar water jets which are directed into the provided web supported by a moving conveyor (flat or cylindrical surface). Fibre entanglement relies on the transfer of kinetic energy from the water jets to the web and the constituent fibres to introduce mechanical bonding. During the hydraulic entanglement process, the fibres are intertwined with each other due its interaction with the water incident from the water jets and the supporting surface.

The water eddies produced from the water jets cause either fibres emigration in the web or entanglements. The de-energised water is drawn through the conveyor to the vacuum box for recycling and reuse. However some of the water remains with the web. This method is suitable to produce multilayered webs(Russell 2007)

Spunlaced fabric is able to produce nonwovens akin to conventional fabrics and fulfil both aspects of traditional fabric strength and durability on the one hand and good handle and drape on the other hand without manipulating fibres into yarns or yarns into fabrics. It is one of the softest nonwoven fabrics. They do not include binders in their components, which enhance their free feel. The free fibres allow them to be superior over the rest of nonwovens, which allow them to drape and behave like woven and knitted fabrics. They have a wide range of weights. Therefore, they have different durability, softness and drape properties (EDANA 1988; INDA 1995).

The global production of spunlaced nonwovens grew an average of 9.5% for the past five years to a total of 819,000 tons in 2011, according to a recently released report from from INDA, Association of the Nonwoven Fabrics Industry, titled “Global Spunlaced Technology Markets and Trends—2011-2016” and will continue to grow at an average rate of 8.2% a year through 2016.

The largest end-uses for spunlaced nonwoven substrate materials are wipes. Other end-uses include surgical gowns and surgical patient drapes, and substrates for coating and laminating, industrial apparel and filtration media (INDA 2012b).

#### 5.2.2.3.3 Factors affecting fabric produced

In this process, the energy (specific energy) applied on the web affects fibre rearrangement (planar and transverse directions), entanglement, degree of bonding, fabric properties ( such as: consolidation, thickness,) and economic

efficiency. The energy is dependent on water flow rate, pressure, conveyor speed, web density and thickness and the spatial arrangement of wires in the support surface.

The degree of bonding is affected by fibre type, pressure profile and web weight. Maximum fabric strength is produced from strong fibres, applying on both web sides rather than one side and high weight webs.

Using (water) pressure and a combing effect of the jets would produce a drag force effect which enhances the fibres' alignment and increase the MD (machine direction)/CD (cross direction) ratio. However, increasing the jet pressure would make it difficult to remove the fabric from the conveyer belt.

The jet marks are characteristic features of hydroentangled fabrics, they are positioned on parallel tracks in the MD of the fabric. Using high pressure in the beginning of the process or an incomplete prewetting procedure would make the jet marks more distinctive. Moreover, the conveyer structure could be transferred to the fabric due to the entanglement process. (Russell 2007).

Polyester and viscose rayon staple fibres are the most applied or handled fibres in hydro entanglement bonding.

### **5.2.3 Fibre selection**

Virtually, all types of fibrous materials can be used in nonwoven fabric production, but the required construction of the product and the combination with other raw materials may exclude some fibre types and favour others. They are manufactured from fibrous webs, filaments or layer combinations. The form of the fibres has a great impact on the output fabric characteristics. (Corbman 1983). The flexibility of the manufacturing elements is vital to fit customer requirements. The choice of fibres is dependent on the required properties of the fabric and quality requirements. The available technologies of the fibre manufacturer set the possible products. Using different technologies, it is possible to cover a wide spectrum of fibre qualities. The fibre type is not sufficient to describe nonwoven fibres but essential properties are crimp, length, denier per filament and finish (Buresh 1962).

Fibre requirements for manufacturing nonwovens are less than fibres for spinning to the extent that waste fibres are able to be used in some kinds of nonwoven production processes (Cusick *et al.* 1963).

Manmade fibres including polypropylene, polyester, viscose rayon, acrylic and polyamide dominate the nonwovens industry manufacture (Russell 2007). According to a report published by Edison Investment Research in January 2010 about the nonwovens sector, Polypropylene occupies around 30% of the nonwoven market (Edison Investment Research Limited 2010). Polypropylene dominates the nonwoven industry due to several advantages including its ability to: produce light weight fabrics (due to low density and

specific gravity), be manipulated using finishing treatments (due to its hydrophobicity), produce good bulk and cover, be stable chemically, be resistant to biological degradation, have good strength properties and resistance to abrasion. Its properties could be modified using auxiliary chemicals. It has a combination of properties which provide manufacturers with versatile raw material for nonwovens at a competitive price (Russell 2007).

In the hydroentangling method, virtually, all synthetic fibres could be processed. However, the fibre employed has an important role on production and economic efficiency, and fabric properties. Fibres with good flexibility and wettability properties are required to produce coherent fabrics with low energy consumption. Fibre flexural rigidity is affected by its diameter, Young's modulus, cross sectional shape and density. Some of these properties are moisture dependant such as Young's modulus. Viscose rayon fibres have low wet modulus which shows the reason for its easy hydroentangling. Fine fibres have better hydroentangling efficiency than coarse fibres. Fibre linear density ranges between 1.1 - 3.3 dtex. Fibres with 1.7 dtex/ 38 mm, 3.3 dtex/ 50 mm, 3.3 dtex/ 60 mm for linear density and fibre length respectively are common combinations (Russell 2007).

Hydroentangled nonwovens made from staple fibre are not as durable as those made from filament and are better suited for single-use products. However, nonwovens made from filament will produce superior durable products without the addition of any binders. However, the addition of an appropriate binder to nonwovens made from staple fibre webs also can enhance its durability. The choice of staple versus filament depends on the costs involved. As the capital costs for a spunbond/hydro system are significantly higher than those involving carding machines (Pourdeyhimi 2004).

#### **5.2.4 Finishing treatments**

This is the last process in nonwovens production. It is used to add to or improve bonded web properties. Chemical treatments can be performed using chemical substances added before or after bonding, in addition to the applicable mechanical treatments which could be applied on the nonwoven fabrics. Conductive, flame retardant, water repellent materials are examples of treated nonwovens. They could also be combined with other materials to produce composites (Rupp 2008).

Durable nonwovens can be dyed, printed and finished using the same type of equipment used to process traditional textiles and adapt them for apparel use. Advanced finishing techniques can improve the nonwovens properties to acceptable levels (Pourdeyhimi 2004).

## **5.3 Nonwovens characteristics**

### **5.3.1 Nonwovens versus woven**

When nonwovens are compared with traditional fabrics such as woven fabrics, several features for nonwovens are found. In the manufacturing processes, woven fabrics are produced using spun warp and weft yarns. Warp yarns must be converted into weavers' beams. In nonwovens carded fibres are directly used in making webs and further fabrics.

The manufacturing of woven fabrics includes opening, blending, carding, combing, drawing, roving, spinning, winding, sizing, beam preparation and weft ends for the weaving process. However the manufacturing of nonwovens comes from the carding process which is followed by the web formation process. Moreover, woven fabric production processes often take place in different factories, whereas nonwoven production is carried out in one place (single line). This shows the increased number of machines employed in manufacturing woven fabrics than nonwovens which decreases the cost of nonwoven by 30% due to initial investment, land and labour requirement and increase production rate.

Backer and Petterson in 1960 compared the mechanical behaviour of woven and nonwoven fabrics. Woven fabrics for apparel end use were able to resist manufacturing and usage stresses. They have particular extensional response to uniform two-dimensional stresses, uniform bending (into the third dimension), and stress concentration, both in and out of the fabric plane. This behaviour is due to the distinctive structure of woven fabric structure which gives it a significant nature/style of deformation. Therefore they found that engineering nonwovens for apparel end use should either emulate these properties (by developing alternative production techniques) or exploit their characteristics in particular end uses rather than the traditional woven ones.

It was found that woven fabrics had good tolerance for stress applications, more than nonwovens. Differences between these two textile structures were put down to variance in the mechanism of deformation and recovery in manufacture and in end usage which were outlined in the paper. They determined causes of nonwovens' lack of 3D deformation and drape recovery from bends and tensile extension (Backer and Petterson 1960).

As with woven fabrics, apparel nonwovens should be engineered to tolerate being subjected to manufacturing and usage stresses. These stresses could be measured using FAST and KES.

Lamb and Costanza in 1975 discussed the superiority of nonwovens to woven fabrics due to the low cost resulting from the high production rates. This advantage could suggest replacing woven fabrics by nonwovens in the



apparel industry. However, this was hindered by the lack of required mechanical properties in nonwovens as an example poor drape and flexibility (Lamb and Costanza 1975).

Hammad in 2010 stated that nonwovens have many advantages over woven fabrics, these are the production rate, due to elimination of yarn preparation processes and the fabric production process of web formation and bonding are faster than the conventional methods. This can be made in the following example for producing 500,000 metres of fabric which requires 6 months in the woven technique compared to 2 months in manufacturing using nonwoven technologies. The nonwoven technologies require less labour because of their high automation. They use energy efficiently and produce engineered fabrics which could produce a wide variety of properties (Hammad 2010).

Johnson *et al.* stated that nonwoven wool weed mats placed around seedlings, inhibit weed growth when the plants are young and then break down and fertilise the soil as the trees grow (Johnson *et al.* 2003). This is not applicable in traditional fabrics.

### **5.3.2 Nonwovens for apparel manufacture**

Nonwoven fabrics do not unravel; therefore, seams do not need to be overlapped, making it easy to incorporate shaped hemlines into the garment design. Seams within the garments also do not require finishing. Nonwoven fabrics are easy to cut and offer a wider range of designs than woven fabrics. Nonwovens provide more “sewing” options than woven fabrics (Chaudhari *et al.* 2012). The researcher is not convinced with these findings.

The advantages of using nonwovens are diverse such as dimensional stability (even in high temperature e.g. clothes drying cycle), easy to slit, die-cut, sew, seam, glue, laminate and trim, without fraying, light weight, ease-of-use, improved adhesion, softness, easy to add scent, anti-static, and softener treatments, colour stability, high tear, breaking, puncture and abrasion resistance, stretchability, strength and chemically inert (EDANA 2012a).

Nonwovens are engineered fabrics that may have a limited life, single-use fabric or a very durable fabric. They have specific characteristics that allow them to make specific performance in functions, like: absorbency, liquid repellence, resilience, stretch, softness, strength... etc. They are capable of a good balance between product use-life and cost. They can resemble woven fabric appearance, texture and strength. Using them with other materials widens the output product range (Corbman 1983).

### 5.3.3 Mechanical properties including drape

One of nonwoven fabric manufacturing aims is reproducing textile-like fabrics in terms of their mechanical properties. The ability of nonwovens to be made in apparel products is judged according to their physical and mechanical properties. Nonwoven mechanical properties have been long studied to detect their similarity to traditional textiles.

The low drape of nonwoven fabrics has precluded their usage in the apparel industry. However there has been substantial progress in nonwoven fabric properties since the studies showed poor drapeability of nonwovens compared to traditional fabrics. Studies concerned with nonwovens drape are now reviewed.

Cusick in 1962 investigated subjectively the drape amount and preference of a group of six fabrics including two nonwoven (bonded-fibre) fabrics. Half skirts were tied on a model and assessed by a panel of judges. The nonwoven fabrics were the lowest drapeable fabrics. However one of them was preferred to one skirt made of woven fabric. Six nonwoven fabrics were tested objectively using the drape coefficient, number of nodes and bending and shearing stiffness. These fabrics were random webs and bonded chemically using a nitrile rubber binder and had different fibre contents. The drape coefficient values ranged between 94.3- 96.3% and none of them draped well or generated nodes on the darpemeter. Nonwoven fabrics measured were found with bending length and shear stiffness higher than apparel fabrics (Cusick 1962).

Cusick *et al.* in 1963 measured selected physical properties of a range of commercially available nonwoven fabrics at that time, including parallel-laid, cross-laid, random laid, composite, and perforated fabrics. Two woven fabrics were also examined for comparison. They found that the nonwovens lacked the attractive appearance and aesthetic appeal of the woven fabrics. Parallel laid fabrics were preferred over random and cross laid fabrics. Fibre and binder properties and the nature of the association between them and the web structure characterised the nonwovens' mechanical behaviour.

The nonwovens and wovens measured had significantly different behaviour. The woven fabric strength was higher than nonwovens except parallel-laid nonwoven fabrics. Generally, the initial modulus which was dependant on fibre type, increased with the fabric nonwoven density. Rupture, bursting and tear strength were higher for woven fabrics than nonwovens. The tear strength had the least difference between the two types of fabrics. Nonwovens had higher crease resistance than woven fabrics. The bending length of the nonwovens were higher than the woven fabrics' with ranges 10-4 cm and 1-4 cm respectively. The nonwovens had higher shear moduli than the wovens. The nonwovens had lower drape than woven fabrics, the nonwoven DC was around 96% and the woven fabrics had DC between 71

and 39%. One of the woven fabrics (rayon sailcloth) had drape behaviour similar to the nonwovens. They found that the drapemeter was insensitive to differentiate between fabrics of high DC including nonwovens. The drapemeter dimensions were developed for measuring woven fabrics and were not suitable for nonwoven fabrics (Cusick *et al.* 1963). This could support this current research study's objective to develop an alternative drape measurement system for measuring nonwovens drape.

Hearle *et al.* studied the impact of fibre, binder and weight on nonwoven fabrics' properties. Fabric initial modulus was correlated with drape coefficient. Fabric initial modulus is related directly to its components' (fibre and binder) moduli. They found that fibre modulus had a significantly higher impact on nonwovens' modulus than the binder modulus. Also, they found that nonwovens with similar drapeability to traditional textiles (DC around 70%) could be made by employing fibre content with initial modulus around 30 g/tex. Increasing the nonwovens weight threefold was found to improve the nonwoven's drapeability (Hearle, Michie and Stevenson 1964).

In 1965, Cusick tested a group of fabrics including 124 woven fabrics and 6 nonwovens for drape coefficient. The woven fabrics' drape coefficient ranged between 26.4 and 97.2. The nonwovens' DC ranged between 96.3 and 97.7. This means that the nonwoven fabrics had low drapeability and there were woven fabrics with similar drapeability to them (Cusick 1965).

In 1965, Freeston and Platt stated that nonwovens at that time had high stiffness due to their constituent fibres having restricted movement which was due to the type of bonding between them. The existence of binder increased the tensile strength and decreased the flexibility. However, the flexibility could be improved by adjusting the manufacturing processes. It was found that increased fibre length at bond areas between fibres, fibre density and the distance between bonding points and using binders with improved mechanical properties (lower moduli with maintenance of elastic recovery and strength) were able to enhance the flexibility (Freeston and Platt 1965).

Michie and Stevenson studied improving the aesthetic characteristics of nonwoven fabrics while retaining the initial fabric strength. They studied the effect of stretching on the mechanical properties of the nonwoven fabrics. They determined that stretching beyond a threshold value of 3% decreased the initial modulus, shear modulus, bending length, and drape coefficient. Slight change was found for the rupture stress. However, no effect was found for the breaking strain and the elastic recovery. The drape coefficient showed significant relationship with bending length, but this was not true with shear modulus. The drape behaviour was improved significantly for the more extensible fabrics, in the best case, DC changed from 96% to 91%. It was determined that the improvement in drape is, therefore, greater than

might be gauged from the rather small decrease in drape coefficient and is certainly significant. At the same time, the fabrics cannot be claimed to have reached the stage of reasonable drape in the textile sense (80% highest) (Michie and Stevenson 1966).

Zeronian and Wilkinson related nonwoven bending length and modulus to the draping quality of fabrics. However, they stated that initial modulus is not easily related to nonwoven drape if it differs inconstantly with the bending modulus. The heat-bonded nonwovens acted more similarly to elastic homogenous materials than the saturated-bonded fabric. Uniform distribution of binder and thickness were required if equality between bending modulus and initial modulus which provides moduli similar to homogeneous elastic material, was to be achieved. Moreover, they stated that nonwovens of viscose rayon fibres grafted with poly- n butyl acrylate had the highest moduli due to its high adhesion effect. Low bending modulus was required for improved drape. Therefore, strong saturation-bonded fabrics which had high initial modulus subsequently had poor drape behaviour unless the high initial modulus is coupled with low bending modulus. This impact would be achieved by increasing the binder content in the inner side of the nonwovens than the outer sides which would be able to enhance the draping quality (Zeronian and Wilkinson 1966).

Sengupta and Majumdar found that drape and handle of parallel-laid nonwoven fabrics of xanthate-binder and cotton fibres improved with the addition of a wetting agent, as inferred from the values of initial moduli (Sengupta and Majumdar 1971).

Newton and Ford in 1973 stated that nonwoven stiffness and strength have been long linked to each other. Stiff undrapable nonwovens had always high strength. This means that there had to be a choice between engineered fabric stiffness or strength which prevents nonwovens from being used in apparel manufacture. However, recently, nonwoven properties were improved and became more textile like with good drape and strength properties (Newton and Ford 1973).

The performance characteristics of seven fusible interfacings (woven, knitted and nonwoven) including drape in terms of their effect on face fabric were investigated by Koenig and Kadolph in 1983. The drape coefficients of all interfaced specimens were higher than face fabric with no interfacing. A similar drape profile was found for specimens with interfacings within the same physical structure group, however different drape profiles were found for each interfacing group from different groups. Interfaced specimens draped parallel to their least rigid direction (the bias direction) when interfacings had similar rigidity in lengthwise and crosswise directions. However, they draped parallel to the lengthwise direction when the interface fabric's lengthwise rigidity was greater than its cross direction ( oriented

web). Interfacing structures with the least rigidity had the least effect on the drape configuration of the fabric with no interfacing (Koenig and Kadolph 1983).

Amirbayat and Hearle's point of view was that nonwovens had properties midway between textiles and paper properties, this could enable them to be more employable for textile products due to their increased resemblance to textile properties (Amirbayat and Hearle 1989a).

Patel and Warner developed a new model to predict the bending behaviour of point bonded nonwoven fabrics. The bending performance of nonwoven fabric was estimated from the basic fibre and fabric properties i.e. fibre diameter and modulus, fabric and bond thicknesses, as well as unit cell and bond dimensions. This could assist fabric designers to determine its drapeability (Patel and Warner 1994).

These bonding processes using binders, however, seriously limit the relative freedom of movement between fibres, and the most limiting property of nonwovens was their poor drape. Termonia showed that nonwovens with a three-dimensional fibre orientation distribution have a much lower bending stiffness than those with a planar distribution. Variations in fibre density across the fabric thickness are also of great importance. Random variations due to inconsistency in the laydown process increased the bending stiffness. Whereas the latter can be considerably decreased by concentrating most of the fibre weight within the neutral (or mid-) plane of a fabric. This study agrees with Freeston and Platt's results (Termonia 2003).

Saleh in 2003 investigated the capability of using nonwovens in the apparel field – especially as shirting fabrics in terms of their mechanical properties. The FAST properties of nonwoven fabrics including different bonding methods (i.e. hydroentangled, chemically bonded, thermal bonded and hydroentangled + chemically bonded) and fibre content (i.e. Viscose rayon, polyester, cotton and Nylon) were compared with woven fabrics (already used in apparel production). The four types of mechanical properties' curves/trends on polar plot, generally, showed similar silhouette (behaviour/trend). However, the hydroentangled fabrics had the lowest values of bending length, bending rigidity and shear rigidity and the highest extensibility values.

So, she found that the hydroentangled nonwovens could show good handle properties compared to other nonwovens. Saleh referred this ability to the free fibres in the cross section due to their twist and migration within the fabric structure.

Saleh also found that the mechanical properties of the hydroentangled nonwovens lie between the maximum and the minimum values of the woven shirting fabrics except the extension at 5, 20 and 100g/cm in the crosswise direction. This was considered probably to the low weight of the tested

hydroentangled nonwovens, as there was a reverse relationship between fabric weight (area density) and extensibility.

She has concluded that the potentiality for the presence of nonwovens- as light weight fabrics- in the apparel industry was dependent on hydroentangled fabrics (based on their low stress mechanical properties) (Saleh 2003).

#### **5.4 Nonwovens and apparel industry**

Nonwovens are able to be used as interlinings (fronts of overcoats, collars, facings, waistbands, lapels etc), disposable underwear, shoe components (shoelace eyelet reinforcement, athletic shoe and sandal reinforcement, inner sole lining, bag components, bonding agents, composition and (wash) care labels (EDANA 2012a).

Shishoo *et al.* stated that the balance between different properties such as drape, thermal insulation, barriers to liquids, chemicals, and micro-organisms, thermal resistance, fire-retardancy, antistatic properties, stretch, physiological comfort, etc. is required in manufacturing apparel fabrics. Advances in technologies has enabled manufacturers to combine successfully the consumer requirements of aesthetics, design, and function in apparel fabrics for different end-use applications (Shishoo, Dartman and Svensson 1997).

Manufacturers and researchers of nonwoven fabrics have found that there is a necessity for making a step forward into the clothes and fashion industry. Innovative designers could fulfil this aim if they are interested in applying new technologies and materials. It is required to widen the range of fabrics used in the apparel industry by involving fabrics with different properties/potentialities from traditional fabrics and to go through the implementation process. Nonwovens are one of the versatile materials which would be employed in apparel industry for different reasons, they have significant appearance and style which differs from traditional fabrics, can be coloured (dyed and printed) easily, do not fray which makes production processes easier, faster, giving different possible applications and are able to be embroidered (Dhange, Webster and Govekar 2012).

Factors encouraging the employment of nonwovens in the apparel industry including the advanced technology in engineering nonwovens which could enable textile workers to generate nonwovens with improved physical properties necessary for clothing use including handle, drape, stretch, abrasion resistance etc., their adjustability to be engineered for certain end-use/purposes (disposable or durable). Also, fast fashion trends require materials with high production rate like nonwovens, alternative colouration and designing and finishing techniques which can be applied in nonwoven

production to produce distinctive fabric styles, alternative garment assembly methods including replacement of sewing threads with ultrasonic or thermo fused seams, thermo-forming of garment panels, removal of edge-fraying and obviation of edging and modification of block patterns to simplify the garment production process (University of Leeds 2012).

#### **5.4.1 Nonwoven interlining**

Interlinings are used to improve, strengthen and/or retain shell fabric garment style and design for areas which would be limp or would stretch during wearing, washing and cleaning. They are used either in large or small parts in the garment. They are made of synthetic fibres, mostly from polyester, polyamide and/or viscose rayon. They could be resistant to wear, laundering and/or dry-cleaning. They could be plain or coated with adhesives for fusing in the subsequent process of garment making. A coated interlining adheres to other fabrics by the application of heat and pressure (Miller 1992).

Interlinings were sewn, as sub-assemblies of fabrics inserted between the outer face and the lining of a garment. In the early 1970s, the first fusible interlinings came on the market. The products were inflexible and rigid. The rigid dot or powder coating was a polyethylene, similar to sticky plastic.

Fusible interlinings occupy around 80-85% of all interlinings used in apparel manufacture. They are more timesaving than interlinings that have to be stitched. There are three types of fusible interlinings. These are adhesive, weld able and mouldable nonwoven interlinings. Adhesive interlinings adhere to the shell fabric using heat pressure and occasionally steam due to the existent constituent adhesives. In weldable interlinings, heat using ultrasonic or other frequency methods or steam are used to weld them to the shell fabric. The mouldable nonwovens are usually used in small areas in the garment and able to be thermally moulded (Saleh 2003).

Over the years, interlinings improved considerably, in parallel with the quality of the nonwovens and the chemistry of the coatings. The products have become softer and more lightweight, and today, fusible interlinings are an integrated part of all high quality womens- and menswear (Rupp 2009).

#### **5.4.2 Outer wear**

At the end of the 1960's, the era of mass consumption in the industrialised world arrived and the world became increasingly a throwaway society, disposable dresses made from nonwoven fabrics (paper dresses) were very fashionable in the USA. At that time dresses were characterised by simple form, mini length and graphical motifs. They were used as promotional tools for commercial companies and presidential campaigns. This achieved great success which encouraged many designers and manufacturers to adopt the

production of these dresses. Spunbonded polyester or rayon were widely used. One of the advantages of this dress apart from its low cost, was its customisability by adjusting its length or by painting white plain dresses. Dupont developed a paper made of synthetic fibres (an early form of Tyvek) which was wet resistant (FIDM museum 2009; MPH Design 2012).

Paper dresses were adopted by fashion leaders. They used tissue paper laminate reinforced with viscose rayon (Russell, Beverley and Saleh 2006).

At this period, experimental trials were carried out to make alternative Melton and blazer cloths using the needlepunching method employing woollen blended fibres. They were treated by dyeing, finishing, milling and decatizing. The products were accepted to a good extent. However they were not highly successful in balancing between good drape strength and abrasion resistance. So, they did not progress from the experimental status. Garments made by the stitchbonding method were of wool-PET blends but had poor durability and were stiff (Russell, Beverley and Saleh 2006).

By 1970, paper dresses had virtually disappeared from the market. The world became more concerned about the negative environmental consequences of this fad. However though this was dead decades ago, it is interesting to find one non profit organisation "ATOPOS" working on exploiting the new technologies in the area of fashion and design and from the reverse/opposite environmental view (in 1968). This company ran an exhibition in 2008 entitled "RRRIPP!! Paper Fashion" as a consequence of research into paper clothing (Zidianakis 2008).

However, though nonwoven garments disappeared from the apparel market, there were research studies to investigate the opportunity of promoting nonwovens in the apparel manufacture industry. Nonwoven fabrics' cost, strength and production/ manufacturing technology has prevented them from being adopted in the apparel and fashion industry. The suitability of nonwovens in making apparel products in terms of deformation and recovery are established according to traditional fabrics' mechanical behaviour.

Jowett in 1975 found that it is possible to produce technically acceptable apparel fabrics by needle-punching. The production processes involved needle-punching a fibrous fleece onto a scrim, consolidation by Fibrelocking followed by conventional dyeing and finishing (Jowett 1975).

Also, Floyd published a paper investigating the factors limiting the application of nonwovens in the apparel field. Both technical and aesthetic aspects slow the growth of nonwovens in the apparel industry. Tensile strength, tear strength, drape, abrasion resistance, dimensional stability, seamability and cost of adhesive bonding, stitch bonding and needle-punched nonwovens were investigated. It was found difficult to produce fabrics with good balance between drape and strength. Abrasion resistance



needed improvement in all three types of nonwovens tested. The adhesive bonded fabrics had the worst tensile and tear strength, drape and dimensional stability. The nonwovens were sewable using sewing and welding. Several improvements for the three types of nonwoven were recommended for better acceptability of nonwovens in apparel end use (Floyd 1975).

Greenwald in 1986 developed a new marketing strategy by which the nonwovens industry can prosper in the U.S. furnishing market. There was a decline in weaving and knitting in the textile market areas; however there was growth in the nonwoven and imports areas. On the other hand, the limited volume and limited variety of style and colour almost negates any possible interest or competition for nonwovens. But, the nonwovens were capable of expanding dramatically the market for the individual product by changing the entire distribution and volume pattern. The proposed strategy aimed at replacing woven products and markets for nonwovens where this could be implemented and changing the positioning of these products in the mind of the user. This strategy would allow at least a fivefold increase in the volume due to the use pattern based on cost reduction, availability and consumer acceptance on a major volume scale (Greenwald 1986).

Vaughn in 1988 stated that nonwoven fabrics were used in textile products as new items but not as a replacement for traditional fabrics. They were able to be exploited in making/developing new products. This performance of nonwovens was beneficiary with regard to lower cost, wider and more flexible capabilities than traditional fabrics (Vaughn 1988).

Dutton in 2009 studied the consumer's acceptance of nonwoven fabrics for apparel and accessory end-use through the use of subjective fabric hand evaluation. Comfort depended more on the fabric and not necessarily whether the fabric was a woven or nonwoven. Overall, woven fabrics were preferred over nonwoven fabrics for apparel products. However, nonwovens were most preferred for a tote bag along with a woven fabric. The nonwoven fabric similarities and differences varied over many attributes (Dutton 2009).

In 2010, Webster indicated the importance of exploiting the significant appearance and properties of nonwovens to be adapted in fashion and apparel manufacture rather than emulating traditional fabrics (Webster 2010).

Recently, efforts have been carried out by education and research organisations to employ nonwovens in fashion and apparel making.

University of Leeds staff and students have been studying the use of nonwoven fabrics in apparel since 2005, resulting in a number of collections which have been exhibited globally.

North Carolina State University (NCSU), the Nonwovens Cooperative Research Centre (NCRC) was established as a State/Industry-University Cooperative Research Centre in 1991. Core research programs focus on areas such as: new materials development; existing materials modification; basic studies that lead to a better understanding of technologies; applied research directed at process material/property relationships; and instrumentation and test methods development for nonwoven fabrics.

Canesis Network Ltd founded by Wool Research Organisation of New Zealand in 1961 is a research centre focused on promoting the wool industry and providing product development services to the wool industry. Canesis carried out a research project aimed at the development fabrics and products from wool fibres using different nonwoven structures. They have been working on the development of nonwoven garments as alternatives for traditional wool products and have long believed that the market should be for mature and affluent consumer (Russell, Beverley and Saleh 2006).

Canesis has developed lightweight apparel fabrics with greater stretch and recovery. Researchers have designed a special collection of beautiful 100% wool and wool rich nonwoven fabrics. Current research concentrates on improving the physical characteristics of nonwoven fabrics. Fine-wool apparel fabrics (nonwoven) that are lightweight with good drape and superior wind-blocking behaviour was one of Canesis developments.

Production of woollen fabrics using nonwoven techniques is a significant opportunity for cost reduction technology which enables wool fibres to be made into new products. The nonwovens process is about five times faster, therefore woollen nonwovens are up to 30% cheaper than conventional wool fabric production (Johnson *et al.* 2003; Anderson 2012).

In 2003, a collaboration between Canesis, Australian Wool Innovations and MacQuarie Textiles was aimed at commercialising these fabrics for use in the fashion industry. It carries on improving and developing nonwoven fabrics for apparel mechanically bonded including colour pattern and texture. Nonwoven woollen stichbonded fabrics blended with polyamide were successfully accepted in the fashion market in the form of durable jackets in Australia (Russell, Beverley and Saleh 2006).

## **5.5 Nonwovens and fashion**

Several fashion designers have used nonwoven fabrics in their fashion shows and designs. Rei Kawakubo designed a nonwoven dress for the autumn-winter 1990-91 collection. A voluminous, full-skirted dress was constructed of what is “quilt batting” in America, and “wadding” in the UK (Rossi-Camus 2010).

Between 1995 and 1997 Manel Torres conceived the idea for Spray-on Fabric. Fabrican Ltd was later founded. In 2000, spray-on Fabric was patented as an instant, sprayable, nonwoven fabric. From its base at the Department of Chemical Engineering and Imperial College London, Fabrican technology has captured the imagination of designers, industry and the public around the world. The technology has been developed for use in household, industrial, personal and healthcare, decorative and fashion applications using aerosol cans or spray-guns. The fabric is formed by the cross-linking of fibres to create an instant nonwoven fabric that can be easily sprayed on to any surface. Its properties can be tailored to meet the needs of each user. A multitude of fabrics are available of varied colours, textures, and properties, all sprayable from an aerosol can (Torres 2010).

In Spring 2006, it was believed that fashion shows were able to help nonwovens to be adopted. Tredegar Film Products provided nonwoven materials for fashion design and merchandising students at Virginia Commonwealth University in Richmond, Virginia. The students made stylish, well constructed, and functional pieces from nonwoven laminates (Kesselaer 2006).

There is an annual student fashion show at the University of Delaware called "Blank Canvas" design competition. Each participant is given the same fabric as a starting point for his/her designs. In 2006, they were challenged to develop fashion apparel utilising a non-traditional fabric. A melt bonded poly-ether ester elastomeric fabric donated by TANDEC (Kimberly Clark's Demique) for the purpose of advancing fashion solutions using nonwoven fabrics was provided to the participating students. The lightweight (approximately 30 gm/m<sup>2</sup>) fabric was white in colour (Zend Non-wovens Co. LTD 2011). The designers had to use multi layers of the fabric and/or add in another fabric, because the nonwoven fabric used is lightweight and sheer. Traditional construction techniques were not suitable for the nonwoven used. A zigzag-type machine stitch designed to allow stretch within the seam was necessary (Orzada 2006).

Nonwoven clothing designs made by NCSU students in 2010 demonstrated that unique clothing can be produced using structures similar to those used in producing fabrics like Freudenberg's Evolon®.

## **5.6 Commercial nonwovens for apparel products**

The apparel market is a wide field in which to use nonwoven fabrics. In addition, they can add to the development of fashionable garments. Introducing nonwoven fabrics into the fashion apparel market requires market and fabric research studies. Apparel designers would be interested to use nonwoven fabrics in different products that may employ the fashion industry requirements of aesthetic values and functions. Recently, several

companies have introduced nonwovens with a textile apparel look (Silva 2010).

### **5.6.1 Evolon fabrics**

However, there was little chance for nonwovens to become outer fabrics. That application was strictly reserved for wovens and knits. This changed with the invention of Evolon (Rupp 2009). Evolon fabrics from Freudenberg company are microfibre based fabric made from spunbonded webs.

The aim of its engineering was to combine the advantage of both staple fibre carded webs (including high softness, drape, bulkiness and resilience) and supunlaid webs (including high machine direction MD to cross direction CD tensile strength) in one fabric. Therefore, endless splittable filaments made of 16 segmented pie, polyester/polyamide (weight ratio 65/35%) of 2 dtex are laid uniformly on a belt. The web is then hydroentangled using high pressure water jets (400bar) and the filaments' cross section is split into multiple microfilaments of linear density 0.09 - 0.13 dtex. Splitting is carried with 97% efficiency and increased by using hollow-core segmented pie filaments. Nozzle diameter, quenching, stretching rate and water pressure affect the efficiency of the splitting operation. This microfibre fabric combines several textile attributes including softness, drapeability and lightness, quick to dry, breathable, absorbent, washable (which make it applicable for durable use) with good strength. Like traditional fabrics it can be finished, dyed and made into garments. It is lighter than traditional equivalent fabrics by 50% or more. It has non fraying edges. It is applicable to different textile fields such as printing media, bed linen, aquatics, coating substrates, window treatment and high-Tech wiping (Russell 2007).

The clothing area is one of the fields of applicable use for Evolon fabrics. It has been used in sportswear and leisurewear. All kinds of stitches could be sewn. The reduction of production process steps allowed increasing production rates with incomparable rates to traditional textiles (mins to weeks), and recycling of water used in this process, makes it eco-efficient. All these factors made it an eco friendly fabric (Evolon 2012). Softening treatment using mechanical tumbling finishing is applied to enhance softness. There are two kinds of Evolon available in white: Evolon standard and Evolon soft (similar to very short piled velvet). Fabric weight ranges between 100-220 g/m<sup>2</sup> (Russell 2007).

### **5.6.2 Miratec fabrics**

Polymer Group Inc. (PGI) produced a collection of nonwoven fabrics using Apex technology including Miratec®, Mirastretch®, Miraguard®, AMIRA™, and Duralace® brands, each fabric brand has its characteristic features. Apex technology produced strong and durable fabrics. Fabric weight ranges between 50-400 g/m<sup>2</sup>.

Miratec nonwoven fabrics are durable fabrics. They are characterised by high strength, durability and uniformity. They have good resistance ability for tear, fray, pilling and shrinking. They would achieve the strength and durability of high weight woven fabrics with lighter weight fabrics. Traditional finishing techniques could be employed including jet dyeing, rotary screen printing, heat transfer printing, sanforising, coatings, etc. This fabric is recommended for the apparel market (PGI group 2012).

It has a structural appearance similar to traditional fabrics. They have a 3D patterned structure due to the hydroentanglement on a supporting surface using a laser imaged platform. The entangled fabrics undergo a finishing treatment to enhance fabric softness and drape using polymeric binders, giving them elastic properties and compressive shrinkage (e.g compaction by sanforising). They are able to be dyed and printed using traditional techniques (Russell 2007).

Levi's engineered Jeans concept produced from Miratec® fabric is an example of a woven fabric substitute that would be akin to woven material appearance. However, producing mechanical properties similar to textiles is still a challenge (Russell, Beverley and Saleh 2006).

### **5.6.3 Tencel®**

Lenzing group supplies the textile and nonwovens industry with man-made cellulose fibres. The Lenzing Group combines the manufacturing of all three manmade cellulose fibre generations— from the classic viscose to modal and lyocell (TENCEL®) fibres. Its technology is able to produce fabrics for apparel end use (The Lenzing Group 2012).

### **5.6.4 Ultrasuede®**

In 1970, Miyoshi Okamoto succeeded to create the world's first ultra-microfibre which was described as an artificial substitute for suedeleather. Ultrasuede has applications in high-end fashion including shoes and interior furnishings. Its extraordinary beauty—both visual and in the hand—has been a source of inspiration to many of the world's top fashion designers for decades.

Ultrasuede® comes in a range of weights, thicknesses and finishes to meet the specific demands of literally hundreds of products and applications (Fabrics.net 2011).

Halston's best known garment was the Ultrasuede shirtwaist dress that he introduced in 1972. It was one of the most popular dresses in America in the 1970s. Its success stemmed from its plainness, Halston's colour choices, and the convenience of being machine washable (Cole 2002).

Ultrasuede® is a soft, sensuous fabric that is stain resistant, extremely durable (200,000 double rubs Wyzenbeek), breathable and washable (using mild soap and water, or even in a washing machine).

Ultrasuede® from Knoll Textiles remains current in the fashion world, as seen in the Fall 2005 catwalk fashions of Benjamin Cho and Jeremy Scott. Today Ultrasuede® fabrics are also used in products from key fashion brands like Nike and Louis Vuitton, as well as automotive brands like Porsche, Mercedes and BMW (Toray industries Inc. 2006).

#### **5.6.5 Neotis™(Formerly known as DuPont Inova™)**

A fashion show in Paris in 2001 showcased a range of innovative nonwoven fabrics developed by a DuPont spin-off company Neotis. Several leading fashion brands such as DKNY and Calvin Klein have employed this company's nonwovens. However, in March 2002, DuPont closed the Neotis Studio due to the lack of demand for nonwoven apparel (Russell, Beverley and Saleh 2006).

#### **5.6.6 Tyvek®**

This is a flash-spun PE fabric able to be used as durable clothing fabric due to its inherent dimensional stability, abrasion resistance, tear strength, water resistance and adequate moisture vapour permeability. Tyvek® fabrics are found in commercial apparel products such as sports shoes (and light-weight jackets. Moreover, there have been some trials made by fashion designers specially in wedding dresses. Male and female lightweight Tyvek® jackets are also marketed by American Apparel® as casualwear in the USA and Europe (Russell, Beverley and Saleh 2006).

### **5.7 Summary**

Nonwoven fabrics have long been employed in a narrow range of outerwear products (Only 1% of nonwoven fabric is utilised for apparel applications) (Dhange, Webster and Govekar 2012). However it has been used widely for different functions in making apparel and accessories for single-use and highly durable products such as protective clothing, garment linings and interlinings, insulation waddings, shoe linings and synthetic leather fabrics. Employing nonwovens for certain purposes and applications is conditioned by their physical and mechanical properties which subsequently affect their performance. The properties could be adjusted at the manufacturing process and fibre selection and engineered according to the product specifications.

Researchers have introduced some ideas to enhance nonwoven properties for apparel manufacture and use. Nonwovens have been developed and progressed substantially and improved in terms of manufacturing techniques to the extent that has made them able to be used in apparel making.

Characteristics of the end product are dependent on the manufacturing technique and fibres used.

The importance of adapting nonwovens in the textile industry has exceeded their original advantage of lower cost than traditional fabrics to substitute them for having significant and particular usability which could not be achieved using the traditional fabrics resulting from their ability to be engineered.

Several nonwoven manufacturers have taken the challenge of taking up nonwovens in apparel fabrics (McIntyre 2009). Several designers and academic organisations working in garment and fashion manufacture are attracted by the distinctive unique appearance which can be produced using available nonwoven fabrics.

Hydroentangled nonwoven fabrics have been found to be able to perform in a similar way as traditional fabrics in terms of durability, launderability, flexibility, softness and conformability.

## **Chapter 6**

### **Fabric range identification**

#### **6.1 Introduction**

Nonwovens are often used in the textile (apparel) industry whether as lining fabrics or disposable gowns for medical use. It is rare to find them in the apparel market as shell fabrics of a garment, top, skirt, etc. Their poor appearance and durability has been the reason for that rare existence. It is evident from the literature review that a fabric appearance is correlated with its mechanical properties. Fabric drape is one of the most important mechanical properties, which affects garment appearance. Perhaps, it is one of the major nonwovens' drawbacks, which impedes using them in the apparel industry as shell fabrics. Therefore, it was found that it is essential to study and investigate this property, its measurement and its effect on garment appearance. It is proposed to compare the nonwovens drape behaviour with woven and knitted (conventional) fabrics to help understanding nonwoven fabrics' behaviour.

From the literature review, the drape assessment is mostly carried out using a circular piece of fabric laid/mounted on a supporting body/disc. These evaluations were carried out subjectively by visual assessment using a panel of judges and/or objectively, using the traditional static and/or dynamic drapemeters. These systems focus on using fabrics in studying drape even in investigating the effect of the garment making processes (such as sewing parameters) on its drapeability. It was decided that garment drape would be studied using a garment on a mannequin as well as fabric on a disc.

It was expected that this study would identify and determine an alternative method/system which would produce more dependable parameters than the already existent traditional ones and would consequently give a better understanding for the nonwoven materials for apparel. This system will use a dress on a mannequin instead of a fabric on circular disc (traditional method) which would be more akin to the real apparel drape. A comparison between traditional and the new alternative methods was conducted in this study.

The conventional drape measurement methods applied in this study were selected by reviewing the developed methods by different researchers and scientists starting from Pierce's (1930) Flexometer.



### **6.1.1 Fabrics types**

It was observed in the literature review that hydroentangled nonwoven fabrics have the lowest bending length, rigidity and shear rigidity and higher extensibility compared with other types of nonwoven fabrics (i.e. chemically and thermally bonded) in both machine and cross directions (Saleh 2003). Based on this fact, this type of nonwoven fabric could be taken on in the apparel industry as lightweight fabric.

While the nonwoven garments' drape is the area of this study, it was found that including/involving conventional fabrics (knitted and woven) suitable for making women dress would support the resulting data in terms of subjective and objective comparisons/studies, improve the calculated statistical values and provide clear information about the nonwovens' drape. A group of conventional fabrics were used including two knitted fabrics and five woven fabrics. Their weights were suitable for making women's dresses.

### **6.1.2 Physical properties**

#### **6.1.2.1 Woven fabrics group**

This group consisted of five fabrics. They are coded by a letter (W) followed by a number. Three fabrics (W1, W2, W4) were printed on one surface which signifies the face from the back. Two fabrics (W3 and W5) were plain light beige with different tones (see Table 6.1).

#### **6.1.2.2 Knitted fabrics group**

Two double jersey fabrics were used in this group. One of them was uniform black dyed but its face had a more lustrous appearance than the back. The second fabric is single surface printed. Each fabric in this group is coded by letter (K) and a number follows the letter (see Table 6.2).

#### **6.1.2.3 Nonwoven fabrics group**

A range of nonwoven fabrics (hydroentangled with polyamide and polyester based fibres) were provided by Freudenberg Nonwovens Company, its commercial name is Evolon. Each fabric in this group is coded by letter (N) and a number follows the letter. This group consists of five ecru fabrics with four different weights. Two fabrics from the five have similar weight ( $100 \text{ g/m}^2$ ) but one is softened and the other is not (only one of the five fabrics is not softened). This means that there are two variables in this group, mainly the weight is the distinctive variable. Moreover, the existence of two fabrics with similar weights and only one of them softened would show the effect of a softening treatment on low stress mechanical properties and drape behaviour (see Table 6.3).

**Table 6.1** Woven fabrics' physical properties

Fabric Code	Construction/ Description	Weight (g/m <sup>2</sup> )	Ends/inch	Picks/inch	Yarn details			
					Warp		Weft	
					Fibre type	Count (Denier)	Fibre type	Count (Denier)
W1	Plain	152	97	62	viscose	308	viscose	330
W2	Plain	108	107	60	viscose	120	viscose	120
W3	Twill (warp faced) 3/1	158	110	67	Polyester	180	Polyester	337
W4	Plain	105	102	62	viscose	120	viscose	120
W5	Plain	250	65	60	Cotton	276	Cotton	298

**Table 6.2** Knitted fabrics' physical properties

Fabric Code	Construction/ Description	Gauge	Weight (g/m <sup>2</sup> )	Courses/inch	Wales / inch	Yarn details	
						Fibre type	Count (Denier)
K1	interlock	28	260	70	40	viscose	120
K2	interlock	28	197	70	45	Viscose	120

**Table 6.3** Nonwoven fabrics' physical properties

Fabric code	Quality name	weight (g/m <sup>2</sup> )	Treatment
N1	Evolon	100	Not softened
N2	Evolon 80 Soft	80	Softened
N4	Evolon100 Soft	100	Softened
N5	Evolon130 Soft	130	Softened
N6	Evolon170 Soft	170	Softened

## 6.2 Experimental (Measurement of the low stress mechanical properties)

The low stress mechanical properties of the three fabric groups (woven, knitted and nonwoven) were measured to give clear identification of the fabrics and because of the high correlation between fabric drape behaviour and the mechanical properties (specially bending and shear rigidity properties).

In this study, the FAST system (Fabric Assurance by Simple Testing) was chosen to measure the low stress mechanical properties as it is simple, available and has been used in many research studies. In this system, three properties were measured on three devices and other properties were calculated from the measured values (see Table 6.4).

**Table 6.4** The measured and calculated low stress mechanical properties using the FAST system

Property	Symbol	Direction	Unit
<b>Measured properties</b>			
Bending length	<i>BL</i>	L,C, bias	mm
Extensibility	E at 5, 20, 100 gf/cm	L,C, bias	%
Thickness	T at 2 and 100 gf/cm <sup>2</sup>	No direction	mm
<b>Calculated properties</b>			
Bending rigidity	<i>BR</i>	L,C, bias	μNm
Bending modulus	<i>BM</i>	L,C, bias	Kg/cm <sup>2</sup>
Formability	<i>FR</i>	L,C, bias	mm <sup>2</sup>
Shear rigidity	<i>G</i>	No direction	N/m
Surface thickness	<i>ST</i>	No direction	mm

In this study the lengthwise (L) term was used to identify the measurement directions warp, wales and machine direction, the crosswise (C) term was used instead of using weft, courses and cross direction for woven, knitted and nonwoven fabrics respectively. Letters F and B were used for identifying the face and back of the measured fabric respectively.

It is important to notify that there was a certain sequence for the mechanical properties measurement. Firstly the compression (thickness) test followed by the bending length test and the extensibility tests had to be the last test to be carried out as the samples would be subjected to high extension load and the sample will not be able to be used in any test afterwards.

### 6.2.1 Measurement of the thickness

The thickness of the ten fabrics was measured using the FAST 1 compression meter; six samples for each fabric, only one measurement was carried out on each sample. The samples used in this test were the FAST 2 bending meter samples (see Section 6.2.2.3.3). The thickness was measured at two different loads: 2 (*T*<sub>2</sub>) and 100 (*T*<sub>100</sub>) gf/cm<sup>2</sup>. The difference between the two thicknesses is the surface thickness (*ST*) of each fabric (see Equation 6.1).

$$ST = T_2 - T_{100}$$

where:  $ST$  = surface thickness,  $T2$  = Fabric thickness at 2 gf/cm<sup>2</sup>,  $T100$  = Fabric thickness at 100 gf/cm<sup>2</sup>.

## **6.2.2 Measurement of the bending length**

The bending length of a fabric is its extent (severity) of flexing (bending) action. This extent differs from one fabric to another. It is evident from the literature that there are different apparatus and tests available for measuring the bending length. Applying each method depends on the fabric's tendency to bend under its own weight. It is not apparent that one method is capable of measuring different kinds of fabrics with respect to the ability to bend. There are two main categories for these methods; cantilever and loop tests. The original cantilever method is applicable for medium stiffness fabrics which would bend and intersect with a plane making 41.5° with the horizontal plane. Very limp fabrics which make around 90° with the horizontal plane would be subjected to higher bending action by forming/generating a loop shape to measure their bending length. It was proposed by Peirce that the high stiffness fabrics which are unable to bend in the cantilever test (using the Flexometer) and meet the 41.5° plane could be adapted by adding weight on it (Peirce 1930) to measure their bending length.

### **6.2.2.1 Initial test using FAST 2**

In this research, the FAST system was used for measuring the low stress mechanical properties of the fabrics' range. The FAST 2 bending meter (based on the cantilever principle) was used in measuring the bending length of the range of fabrics which included fabrics with different flexibility levels/degrees (knitted, woven and nonwoven). An initial test was carried out to test the ability of FAST 2 to measure the fabrics' range of bending length. Four fabrics (N2, N4, N5, N6) from the five nonwovens fabrics and three woven fabrics (W1, W2, W4) were able to be measured using FAST2. Five fabrics (W3, W5, N1, K1, K2) from the twelve fabrics were unable to be measured on FAST 2 bending meter. One of them (N1) from the nonwoven fabrics group and two woven fabrics (W3 and W5) were not able to be bend on the bending meter. The other fabrics were the two knitted fabrics which were very limp fabrics and bend in 90° with the horizontal plane.

### **6.2.2.2 Selection of alternative methods**

Thus, there was a need for testing the bending length of the whole range of fabrics using alternative methods. Two other methods were chosen as they would be capable of measuring these fabrics; these were the Heart loop (developed by Peirce in 1930) and the Bending loop test proposed by Stuart and Baird (Stuart and Baird 1966). The first was proposed and used

efficiently in previous studies concerned with limp fabrics. The second test was compared by the developers to a Shirley stiffness tester and they proposed that their method would be used efficiently as an alternative method for the cantilever method (Cassidy *et al.* 1991), as no significant difference was found between the two methods for normal textiles. From the initial study of using the Bending loop and Heart loop tests, both of them were able to make the required loops for all fabrics.

From the initial test, the cantilever method (using FAST 2 bending meter) which employs the principle of the Shirley stiffness tester - was not able to measure 5 fabrics, it was included as one of the alternative methods. This tester showed a good correlation with the subjective assessment for fabric stiffness (Abbott, 1951) and was used in further study as the standard method for measuring the fabric rigidity (Hynek and Winston 1953; Abbott 1951) and used in a British Standard for measuring fabric bending length and flexural rigidity (British standard Institution 1990).

The correlation between and comparison of the four methods were carried out using the seven fabrics' results which were able to be measured by the four tests i.e. FAST2, Shirley, Heart loop and Bending loop tests.

The bending length values from one of the two methods which was able to measure the bending length of the twelve fabrics will be used in further calculations of the bending properties. Therefore, further comparative study was carried out between these two methods in order to select one of them to calculate the rest of the bending properties as it was recommended (to obtain *BL* values from one test to compare directly between them) (Peirce 1930).

### **6.2.2.3 Sample preparation and size**

#### **6.2.2.3.1 Shirley stiffness tester**

The standard rectangular sample size 15 × 2.5 cm as mentioned in the British Standard of measuring bending length and flexural rigidity BS 3356:1990 was used in this test.

#### **6.2.2.3.2 Heart loop and bending loop tests**

These tests were carried out using the same samples as the Shirley tests. The reason for that is regarding the Heart loop test, no required size of the tested strip was mentioned by Peirce the developer of this test. Moreover, a study was carried out to investigate the effect of the Heart loop test strip length on the test's results. It was found that the strip length could be between 12.5 and 37.5 cm without affecting the bending length results' reliability and accuracy (Winn and Schwarz 1939b). Therefore, in the light of

the literature, a sample with 2.5 ×15 cm dimensions was proposed (Shirley's sample) to carry out the Heart loop test.

With respect to the bending loop test, however, samples of size 5 ×30 cm were used by Cassidy *et al.* in studying stiffness of knitted fabrics in 1991. No specified sample size was required or suggested by the developers of this test (Stuart and Baird 1966). Therefore, Shirley's samples were used in this test.

#### 6.2.2.3.3 FAST 2 bending meter

The standard sample size stated in the FAST system manual 5 × 13 cm was used in all tests (thickness, bending length and extensibility).

All tested samples in this study were conditioned in a standard atmosphere: 65 ± 2% relative humidity and 20 ± 2 °C according to the British Standard (BS EN 20139:1992 ISO 139:1973).

It is evident from the literature review that there are different views with regard to the used values to investigate fabric bending length (different approaches in measuring fabric bending length). For instance, firstly it was stated by Peirce that the geometrical mean of the bending length of the main directions (lengthwise and crosswise) is a representative value for fabric bending length. Nevertheless, the literature review showed that most of (maybe all) the researchers were interested in measuring the bending length, measured it in the lengthwise and crosswise directions and presented the bending length of the fabric using their arithmetic mean. Cusick (developer of fabric drape measurement objectively) studied the correlation between the bending length and drape coefficient using the average bending length from  $(BL \text{ lengthwise} + BL \text{ crosswise} + 2 BL \text{ bias } 45^\circ)/4$ .

In this study, the bias direction was measured in all applicable low stress mechanical properties in order to study the difference between the three directions (L, C and bias 45°) in the nonwoven hydroentangled fabrics used and subsequently this direction was measured in the conventional fabrics.

The bending length of six strips in each direction namely; lengthwise, crosswise and bias 45 directions were measured. The face and back bending length of each strip were measured.

It was interesting to compare: the average *BL* of the two main directions and when including the bias direction. Besides, the correlation between the geometrical mean of the two main directions and their arithmetic mean should be studied, as the first was rarely used in studies and the arithmetic

bending length was frequently used instead of the former in spite of what was suggested by Peirce 1930.

## **6.3 Procedure**

### **6.3.1 Shirley stiffness tester**

Measurement of bending length using a Shirley stiffness tester was carried out according to the British Standard BS 3356: 1990 (British standard Institution 1990). The tested fabric was mounted on the tester platform and a graduated ruler was used as a support to push the tested strip forward. When its tip overhung to meet the plane which makes  $41.5^\circ$  with the horizontal plane, the operator recorded the reading off the ruler which moved forward with the strip. The bending length is half the overhanging length.

### **6.3.2 FAST 2 bending meter**

Measurement of bending length using FAST 2 bending meter was conducted according to the steps mentioned in the FAST system manual - the FAST 2 bending meter section. This test process is similar to the previous test however *BL* results are measured digitally. A light beam constructs the  $41.5^\circ$  plane and the device calculates the bending length automatically from the overhanging length in mm when this plane is touched/intersected by the fabric.

### **6.3.3 Heart loop test**

Measurement of bending length using the heart loop test was conducted and the bending length was calculated according to the formula stated in Peirce's paper "The handle of cloth as a measurable quantity".

A long thin clip 7 cm (depth)  $\times$  0.2 cm (height) was used to hang the heart loop and measure its height. The loop height is the length between the clip's upper end and the lowest point in the loop. The clip was fixed horizontally on a flat surface in a position which made it protrude from it, part of its 7 cm depth was fixed on the flat surface and the rest was left to mount the tested strip by opening the clip while the clip is fixed and hang the loop and take it off after finishing the test. A graph paper graduated in millimetres was used and stuck on the vertical surface behind the clip to carry out the measurement easily and accurately as constant conditions for the measurement process is required for the test's repeatability.

While preparing the samples, it is important to mark lines parallel to the two ends of the tested strip. These lines determine the part of the loop underneath the clip and will not be part of the loop to maintain constant loop circumferences. These lines help make the actual circumference of the loop

constant in all measurements as changing the circumference of the loop affects the accuracy of the test results.

In this test, the tested strip was bent around itself to make a loop with 540° (heart shape) and clamped in the clip. A fabric face was the outside layer when its bending length is tested and the tested strip is taken off the clip and reversed to test the back bending length. The heart loop length was measured using the graduated graph paper and its value was substituted in Equation 6.2:

$$BL(\text{Heart loop})\text{cm} = l_0 \times f_2\theta \quad 6.2$$

where:  $l_0 = 0.1337 \times L$ ,  $L = 18 \text{ cm}$ ,  $f_2\theta = \left(\frac{\cos\theta}{\tan\theta}\right)^{1/3}$ ,  $\theta = 32.83 \frac{d}{l_0}$ ,  $d = l - l_0$ ,  
 $l$  = actual length of the loop.

### 6.3.4 Bending loop test

In this test, the tested strip was laid horizontally on a flat surface, one end of the strip was bent back to lay/rest on the other end to form a loop (see Figure 6.1). As in the Heart loop test, the face of the fabric is outside when it was to be measured and the strip was reversed inside out to measure the back of the fabric bending length. A graph paper graduated in millimetres and supported by a vertical block/surface was used to measure the loop height. Equation 6.3 was used to calculate the bending length.

$$BL(\text{loop})\text{cm} = 1.1 \times Lh \text{ (cm)} \quad 6.3$$

where:  $Lh$  is the loop height which is the distance between highest and lowest portions of the loop on the vertical axis between the neutral axes (supposed to be at the sample centre) (see Equation 6.4).

$$Lh \text{ (cm)} = \text{Height of the loop above the the flat surface (cm)} - \text{Thickness(cm) at } 5 \text{ gf/cm}^2 \quad 6.4$$



**Figure 6.1** Definition of the Bending loop height



## **6.4 Comparative studies of bending length measurement methods**

Comparison between methods of measuring the bending rigidity was carried out using: the geometric or arithmetic mean of lengthwise and crosswise directions to present each fabric with one value (Winn and Schwarz 1940b; Winn and Schwarz 1940a) or only the lengthwise values (average of face and back) to eliminate as many variables as possible (Hynek and Winston 1953) or only the face of one direction (warp) (Winn and Schwarz 1939b).

In this study, the bending length values in the lengthwise direction of one face were used as the purpose of the study was to compare between methods only. The comparative studies were carried out in the following terms:

### **6.4.1 Aspects of comparison**

#### **6.4.1.1 Correlation strength**

The coefficient of determination ( $R^2$ ) measures the reliability of predicting one dependent variable by a model (an independent variable). In this study, it was used to measure the relation strength between each pair of the bending length tests.

#### **6.4.1.2 Quantitative relation/prediction**

Modelling a relationship between two variables Y and X would be established using the linear regression by applying/using a regression line. The regression line (called line of best fit) is a straight fit to the observed data of the two variables (*BL* values in this study) plotted on scatter chart. The least squares regression line of Y on X is represented by Equation 6.5.

$$Y = a + bX \qquad 6.5$$

where, b is the line slope and a is its intercept with the Y axis. The slope quantifies the steepness of the line and equals the change in Y for each unit change in X. If the slope is positive, Y increases with X and vice versa. The Y intercept is the Y value of the line when X equals zero. It defines the elevation of the line.

In this study, the best line equation was used to see how one bending length measurement method would be used to predict another.

#### **6.4.1.3 Agreement between methods**

The correlation coefficient is limited in giving information about the type of the relationship between variables, affected by the given data range and

does not identify the type of the difference (random or systematic) between two measurements. Other statistical tools would overcome all these limitations which are appropriate to compare the means of two or more groups.

When comparing two groups, a t-test was used to assess whether or not the means of two groups of *BL* values were statistically different from each other. T-test (paired two samples for means) was chosen as the compared groups has certain sequence of fabrics' values. It compares the actual difference between two means in relation to the variation in the data (expressed as the standard deviation of the difference between the means). The test was carried out using Excel software using a 2 tail distribution.

When comparing more than two groups, one way analysis of variance (ANOVA) was used to detect significant differences between the groups of *BL* values and to see if there are differences between the means at the chosen probability level. If the calculated F value exceeds the tabulated value, there is significant difference between methods. The test was carried out using Excel software using one way analysis of variance (single factor).

In these tests, the null hypothesis is that there is no difference between groups. The tests were conducted at  $\alpha = 0.05$  level of significance. A resulting p-value below 0.05 is generally considered statistically significant, while one of 0.05 or greater indicates no difference between the groups.

#### **6.4.1.4 Precision (reproducibility)**

The precision of a measurement system, also called reproducibility or repeatability, is the degree to which repeated measurements could produce similar results under constant conditions. The experiments' precision was investigated in terms of repeatability and/or reproducibility. Repeatability is the dispersion under constant conditions by using the same instrument and operator, and repeating during a short time period; however, reproducibility is the tests results variance using the same measurement process between different instruments and operators, and over longer time periods. This is the ability of an experiment to be accurately reproduced or replicated, by different methods. It relates to the agreement of test results with different operators, test apparatus or laboratory locations.

The consistency of measurement across experiments is expressed/measured using the standard deviation  $\sigma_f$  and/or the relative standard deviation (RSD) which is also called the coefficient of variation  $CV_f$ . A high  $\sigma_f$  and/or  $CV_f$  value reflects inconsistency among the sample measurements within a group which means that this test has low reproducibility.

In this study, the coefficient of variation was used rather than the standard deviation as the latter is expressed by the measurement unit, however the former is the proportion of variance with respect to the average value which makes the CV more reliable for a test's precision comparison. The following example would demonstrate this fact; consider two fabrics with  $BL$  mean values and  $\sigma$  values as follows: Fabric A ( $BL = 0.5$  cm,  $\sigma = 0.4$  cm), Fabric B ( $BL = 10$  cm,  $\sigma = 2$  cm), using the  $\sigma$  value Fabric A has lower  $\sigma$  than B, however that is not true by measuring the CV of Fabric A is 80% and Fabric B is 20%.

In this study, the coefficient of variation  $CV_f$  of each fabric (from the average and standard deviation of 6 samples/readings) using each method and the average  $CV_f$  of the tested fabrics for each method  $\overline{CV_f}$  was calculated and used to compare the reproducibility (precision) of bending length measurement methods.

#### **6.4.1.5 Sensitivity analysis**

The aim of the sensitivity analysis is to estimate the rate of change in the output of a model with respect to changes in model inputs to investigate how the change in input data/values would produce variance in the output values. Therefore, variation in the output of a statistical model can be referred to as different variations in the inputs of the model. This analysis increases understanding or quantification of a system in terms of relationships between input and output variables and can be used to validate a model.

A test method sensitivity could be measured using the variance of different subjects/fabrics tested using this method, in other words it is the measurement of the test's response to different subjects.

In this study, the sensitivity of the used methods in measuring the bending length was studied using the spread among the average  $BL$  value results from each method for the tested fabrics. This spread/deviation would be expressed by the standard deviation ( $\sigma_m$ ) and the coefficient of variation ( $CV_m$ ) (see Table 6.5 and Table 6.8 to distinguish the difference between  $\sigma_m/\sigma_f$  and  $CV_m/CV_f$ ) and which measures the sensitivity and the relative sensitivity of each method respectively. The higher the  $\sigma_m$  and  $CV_m$  are, the higher the sensitivity and relative sensitivity of the method is, as this means that different fabrics are highly spread and are significantly different when measured/tested using the investigated method (Hynek and Winston 1953). In this study, relative sensitivity  $CV_m$  was used in the comparative studies.

#### **6.4.1.6 Discrimination ability (sensitivity index)**

This parameter takes into consideration the two previous factors, namely the method/test reproducibility and sensitivity and establishes relation between them. It is calculated using the ratio  $\frac{(\sigma_m)^2}{(\sigma_f)^2}$ . This ratio increases with increased measurement method's discrimination ability (sensitivity index) (Hynek and Winston 1953).

#### **6.4.1.7 Variance dependence on fabric stiffness**

The point of this test is to investigate whether or not a fabric's stiffness degree affects its output among/between tests. In this study, the average *BL* values of each fabric from different methods and their standard deviation were calculated. This study investigated the relation between fabrics *BL* values and the variation among tests/methods.

#### **6.4.1.8 Ease of operation and speed of obtaining results**

This consideration involves the ease of sample preparation, mounting and obtaining results. The ease of doing all these steps and carrying out the test procedures were investigated, in addition to the availability of the test apparatus.

### **6.5 Two groups of methods for comparison**

Firstly, the relations between the four methods – which were initially capable of measuring the group of 7 fabrics (W1, W2, W4, N2, N4, N5, and N6) were investigated. Secondly, the two methods which were able to measure the whole range of the tested fabrics were compared using the same assessment terms of the first comparative study. But, the objective of the latter investigation was to choose one of the two methods to carry out bending length measurements for the tested fabrics' directions and faces. The resulting *BL* values from the chosen method were used in further calculations of bending properties (such as bending modulus and bending rigidity). Moreover, the author studied whether or not increasing the range of the tested fabrics by including the two extremes (very stiff and very limp) affects their behaviour or the relation between them (measurement methods).

## **6.6 Results and Discussion**

### **6.6.1 Comparative study of the four methods (Shirley - FAST 2 - Heart loop – Bending loop)**

Table 6.5 lists the *BL* values of the seven fabrics (W1, W2, W4, N2, N4, N5, N6) which were able to be measured using the four methods/tests, Shirley - FAST 2 - Heart loop and Bending loop tests. Each *BL* figure is the average of 6 samples in the lengthwise direction measured on one face. It also presents some of the calculated statistical values.

**Table 6.5** *BL* (cm) measured using: Shirley - FAST 2 - Heart loop and Bending loop tests and other statistical values

Fabric code	Mean <i>BL</i> (cm)					Standard deviation $\sigma_f$ (cm) (Precision)					Coefficient of variation $CV_f$ (Relative Precision)			
	Shirley	FAST 2	Heart loop	Bending loop		Shirley	FAST 2	Heart loop	Bending loop		Shirley	FAST 2	Heart loop	Bending loop
<b>W1</b>	1.36	1.54	1.69	1.59		0.03	0.13	0.05	0.06		1.92	8.56	2.66	3.79
<b>W2</b>	1.15	1.43	1.86	1.77		0.06	0.04	0.08	0.13		5.50	2.85	4.39	7.53
<b>W4</b>	1.63	1.84	2.56	2.14		0.06	0.24	0.07	0.06		3.71	12.78	2.56	2.66
<b>N2</b>	3.28	3.41	2.63	2.73		0.24	0.15	0.06	0.15		7.31	4.49	2.23	5.36
<b>N4</b>	2.89	3.06	2.70	2.96		0.21	0.34	0.05	0.15		7.37	10.96	2.03	5.08
<b>N5</b>	4.08	3.74	3.68	3.90		0.13	0.31	0.09	0.12		3.26	8.34	2.56	3.09
<b>N6</b>	4.90	4.95	3.64	4.22		0.14	0.16	0.10	0.14		2.89	3.32	2.64	3.30
<b>Method Average</b>	2.76	2.85	2.68	2.76	$\bar{\sigma}_f$	0.13	0.20	0.07	0.12	$\overline{CV}_f$	4.57	7.33	2.72	4.40
$\sigma_m$ (Sensitivity)	1.44	1.31	0.77	1.02										
$CV_m = \frac{\sigma_m}{MethodAverage} \times 100$ (Relative sensitivity)	52.2	45.91	28.84	36.86										
$\frac{\sigma_m^2}{\sigma_f^2} \times 100$ (Discrimination)	131.88	44.61	118.96	77.83										

### 6.6.1.1 Correlation strength

The coefficient of determination ( $R^2$ ) was calculated for each pair of the methods and the results are listed in Table 6.6. All methods have strong correlations with each other as all of them have values of  $R^2$  higher than 0.81. However the strongest correlation is between Shirley and FAST 2. The Heart loop highest correlation is with the Bending loop test. However, the Bending loop has approximately similar correlations with Shirley and Heart loop and insignificant lower  $R^2$  with FAST 2.

**Table 6.6** Coefficient of determination ( $R^2$ ) Shirley-FAST 2- Heart loop and Bending loop tests

	Shirley	FAST 2	Heart loop	Bending loop
Shirley	1	-	-	-
FAST 2	0.99	1	-	-
Heart loop	0.86	0.81	1	-
Bending loop	0.95	0.92	0.95	1

### 6.6.1.2 Quantitative relation between methods

The quantitative relations between the methods are presented by the best line fit equation. A pair of methods are equal if in the best line fit equation  $Y = a + bX$  (a equals 0 and b equals 1). Table 6.7 lists the best line fit between the four methods. A high value of a and a low value of b enhances the equality between X and Y.

**Table 6.7** The best line fit equations from the correlation between the pairs of bending length measurement methods

		X axis			
		Shirley	FAST 2	Heart loop	Bending Loop
Y axis	Shirley	1			
	FAST 2	$0.9037X + 0.3614$	1		
	Heart loop	$0.4975X + 1.3073$	$0.5299X + 1.1672$	1	
	Bending loop	$0.6888X + 0.8573$	$0.7441X + 0.6335$	$1.2797X - 0.6719$	1

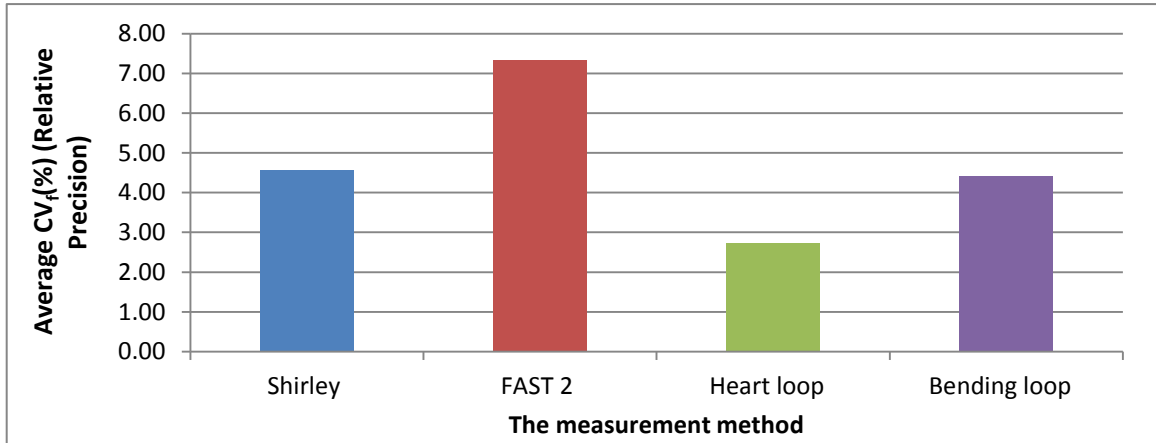
### 6.6.1.3 Agreement between measurement methods

An ANOVA single factor test was carried out to investigate the agreement between the four methods used. In order to have a significant difference between the four methods, the  $F_{\text{value}}$  should exceed  $F_{\text{critical}}$ . It was found that,  $F_{\text{value}} (0.03) < F_{\text{critical}} (3.008)$ . Therefore, it can be concluded that there is an insignificant difference between the methods results at the 5% level of significance.

### 6.6.1.4 Relative precision $\overline{CV}_f$

The coefficient of variation of each measured fabric  $CV_f$  was calculated from its average  $BL$  and standard deviation of 6 measurements. The average coefficient of variation  $\overline{CV}_f$  was used to compare between the four methods' precision. As the test

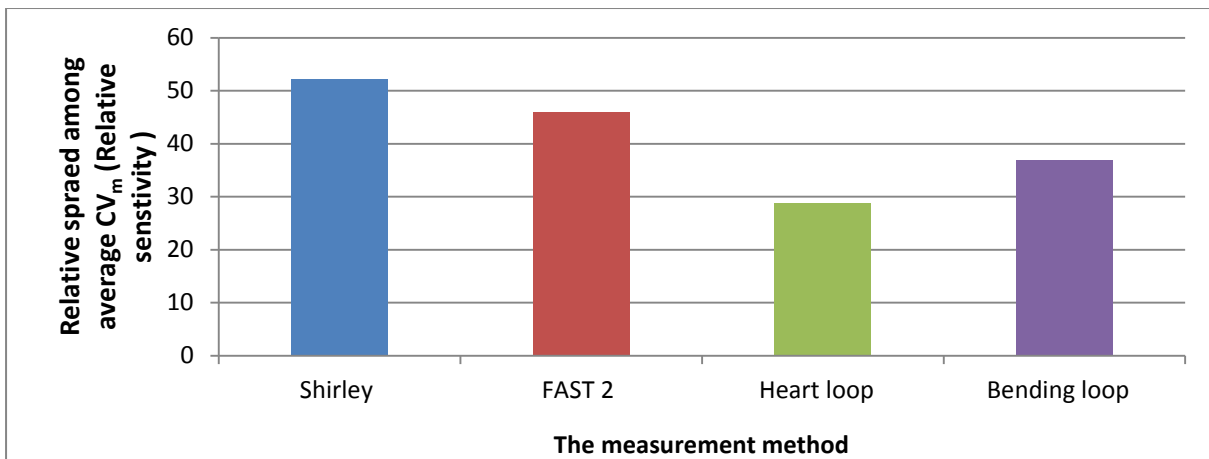
precision correlates negatively with its coefficient of variation, from Figure 6.2 the Heart loop test has the best precision, FAST 2 is the lowest with about 65% less than the Heart loop test. Shirley and loop tests have approximately similar precision but also lower than the Heart loop with about 40%.



**Figure 6.2** Average coefficient of variation of the measured fabrics for the four methods (Shirley, FAST 2, Heart loop and Bending loop)

#### 6.6.1.5 Relative sensitivity CV<sub>m</sub>

The relative spread among average of each method CV<sub>m</sub> was calculated for each method and plotted in Figure 6.3. As a test's sensitivity increases with increased CV<sub>f</sub>, the relative sensitivity rankings are the reverse of the relative precision for some methods. For example, the highest precision (Heart loop) method had the lowest sensitivity. Shirley and FAST 2 tests developed into the most sensitive methods, FAST 2 is 10% lower than Shirley. The change in the Bending loop test sensitivity with regard to its precision was insignificant.



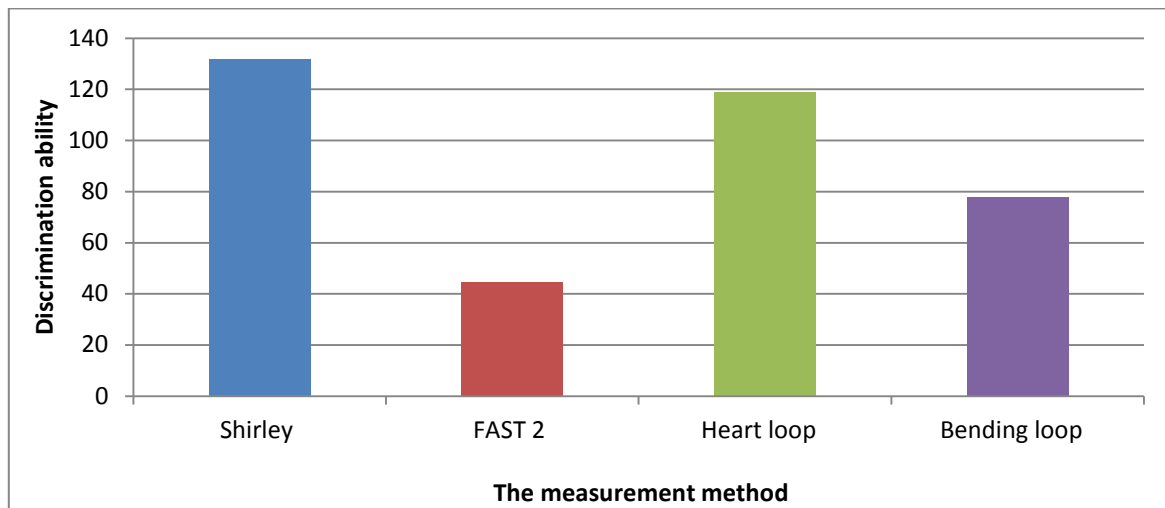
**Figure 6.3** Relative spread among average CV<sub>f</sub> for the four methods (Shirley, FAST 2, Heart loop and Bending loop)



### 6.6.1.6 Discrimination ability

The discrimination ability parameter was suggested to be the most important parameter in the distinction between the methods used as it measures each method's capability to discriminate between fabrics and takes into consideration both the precision and sensitivity factors. From Figure 6.4, the highest discrimination level is for the Shirley tester followed by the Heart loop test. FAST 2 and loop tests have much lower discrimination ability than Shirley and Heart loop tests, with approximately 40 and 65% less than Shirley test (the best) respectively.

It is interesting to observe that the Bending loop test was always 30 - 40% less than the best method with regard sensitivity, precision and discriminationability. However, the other methods had higher differences especially in their precision and sensitivity behaviour.

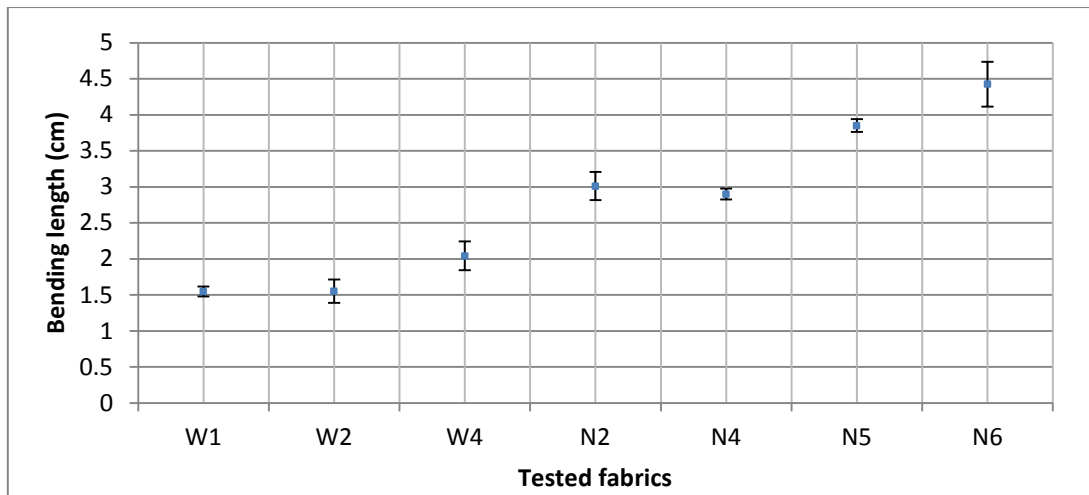


**Figure 6.4** Discrimination ability of the four methods (Shirley, FAST 2, Heart loop and Bending loop)

### 6.6.1.7 Effect of fabric's stiffness on difference between methods

It was shown by the ANOVA test that there are insignificant differences between the four methods. It is interesting to investigate whether or not these insignificant differences are dependent on/correlated with the measured fabric *BL* values.

Each tested fabric is presented by its average *BL* for the four methods (see Figure 6.5). The error between methods used for measuring *BL* are presented by the error bars using the standard error for each fabric. The highest and most significant error is in measuring the highest bending length of N6. Even though; there is not a significant systematic relation between the bending length values and the error and difference of the measured *BL* between methods.



**Figure 6.5** Average *BL* value of each fabric measured using the four methods (Shirley, FAST 2, Heart loop and Bending loop) and their error over the methods.

### 6.6.1.8 Ease of operation

From the experimental work, sample preparation was similar in all methods. Generally, the loop tests do not require devices as the cantilever methods do, but only simple tools available in any physical testing laboratory are required for carrying out the loop tests. The Bending loop test required even fewer tools than the Heart loop did. Although Cassidy *et al.* employed a special box for this test (Cassidy *et al.* 1991).

The four methods had different sample mounting and test procedures, but the tests based on the same principle were similar. The loop methods were easier than the cantilever tests, as in the first a loop is formed and its height is read off, however in the latter a sample must intersect with a plane making  $41.5^\circ$  with the horizontal plane which made them take more time and concentration from the operator than the loop methods. Forming a bending loop was easier than a heart loop. The FAST 2 test required preparation before use such as turning it on before carrying out a test for at least one hour.

The *BL* values were obtained directly in the cantilever methods, however, substitution of loop height into an equation is required to obtain the *BL*. But the Heart loop formula is much more complicated than the Bending loop's, therefore computer software was required to deal easily with the various readings.

All aspects of ease operation were taken into consideration, the Bending loop test was considered the easiest and fastest method, and requires the least amount of tools.

#### **6.6.1.9 Summary**

From the above comparative study, it was found that the four methods of *BL* measurement (Shirley, FAST 2, heart loop and bending loop) are strongly correlated with each other and there are significant agreements between them. The heart loop test is the most precise method. Shirley is the highest in sensitivity and discrimination ability. The stiffness level of the measured fabrics does not affect the stability between methods.

The heart loop and bending loop tests which were correlated strongly and agreed with the cantilever methods (which were used in most of the studies as reliable methods and sometimes as standard methods) would be suggested to do the whole job (measuring the whole range including the two extremes).

The next comparative study aimed to introduce a method which would be able to measure a range of fabrics including materials with bending length values more than the maximum of the cantilever methods (high stiffness) and lower than their minimum (low stiffness/limp).

### **6.7 Comparison between the Heart loop and Bending loop tests**

As the cantilever methods (Peirce and FAST 2 testers) were not capable of measuring the knitted fabrics, two woven fabrics (W3 and W5) and one of the nonwoven fabrics N1 as it couldn't be bent under its own weight. The Heart loop and Bending loop tests were capable of measuring the whole group of fabrics (knitted, woven and nonwoven) and there was a need to select one of them to measure the bending length of the tested fabric, therefore the previous aspects of comparisons were carried out only between these two methods using the average *BL* (of 6 strips) in the lengthwise direction of one face. Moreover, comparisons between the two methods' relations and behaviour before and after involving the five fabrics (K1, K2, W3, W5 and N1) were carried out. Table 6.8 lists the average bending length of the ten fabrics and other statistical values.

**Table 6.8** Heart loop and Bending loop tests *BL* (cm), standard deviation, coefficient of variation and other statistical values

Fabric code	Mean <i>BL</i> (cm)			Standard deviation $\sigma_f$ (cm) (Precision)			Coefficient of variation $CV_f$ (Relative Precision)	
	Heart loop	Bending loop		Heart loop	Bending loop		Heart loop	Bending loop
<b>K1</b>	0.93	0.55		0.04	0.06		4.25	10.27
<b>K2</b>	1.32	0.7		0.08	0.07		6.03	9.93
<b>W1</b>	1.69	1.59		0.05	0.06		2.66	3.79
<b>W2</b>	1.86	1.77		0.08	0.13		4.39	7.53
<b>W4</b>	2.56	2.14		0.07	0.06		2.56	2.66
<b>N1</b>	4.47	4.93		0.13	0.08		2.95	1.68
<b>N2</b>	2.63	2.73		0.06	0.15		2.23	5.36
<b>N4</b>	2.70	2.96		0.05	0.15		2.03	5.08
<b>N5</b>	3.68	3.90		0.09	0.12		2.56	3.09
<b>N6</b>	3.64	4.22		0.10	0.14		2.64	3.30
<b>W3</b>	3.56	3.85		0.13	0.11		3.69	2.95
<b>W5</b>	2.81	2.93		0.07	0.15		2.59	5.18
<b>Method Average</b>	2.65	2.69	$\bar{\sigma}_f$	0.08	0.11		3.22	5.07
$\sigma_m$ (Sensitivity)	1.07	1.39						
$CV_m = \frac{\sigma_m}{MethodAverage} \times 100$ (Relative sensitivity)	40.14	51.6						
$\frac{\sigma_m^2}{\bar{\sigma}_f^2} \times 100$ (Discrimination)	180.62	168.85						

### 6.7.1 Correlation strength and quantitative relation

The correlation between the Heart loop and Bending loop tests rose from 0.95 (before adding the five fabrics B) which is a very strong coefficient of determination to 0.98 (after adding the five fabrics A). This means that involving the five fabrics supports the correlation between them. However the best line fit is slightly improved (see Table 6.9).

**Table 6.9** The best line fit of the correlation between the Heart loop and Bending loop tests before and after adding the five fabrics

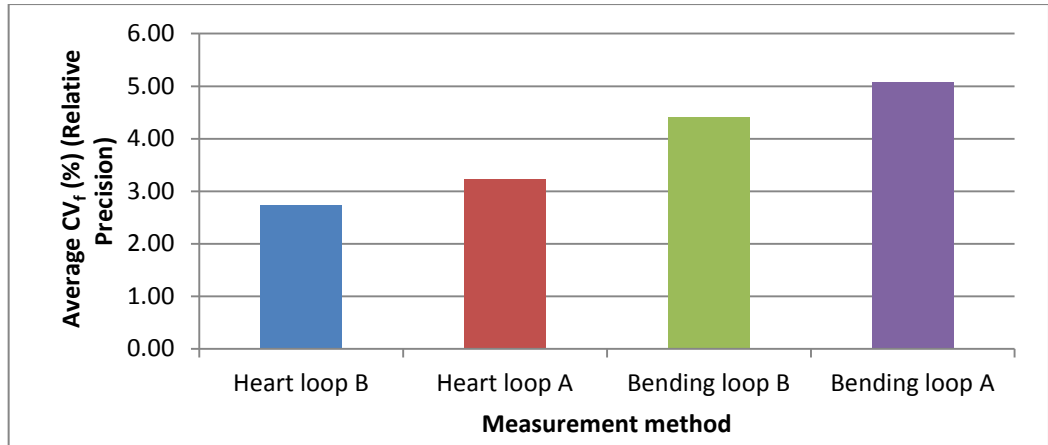
	Best line fit equation:
Before (7 fabrics)	$Y \text{ (Bending loop)} = 1.2797X \text{ (Heart loop)} - 0.6719$
After (whole range)	$Y \text{ (Bending loop)} = 1.2884x \text{ (Heart loop)} - 0.7313$

### 6.7.2 Agreement between Heart loop and Bending loop methods

A t-test (Paired Two Sample for Means) was carried out to test the agreement between the two methods. It was found that the difference between the two methods are not statistically significant,  $p > 0.05$  in both tests for these two methods before (B) and after (A) adding (K1, K2, W3, W5 and N1). This result supports the previous comparison results as the Heart loop and Bending loop were not significantly different.

### 6.7.3 Relative precision $CV_f$

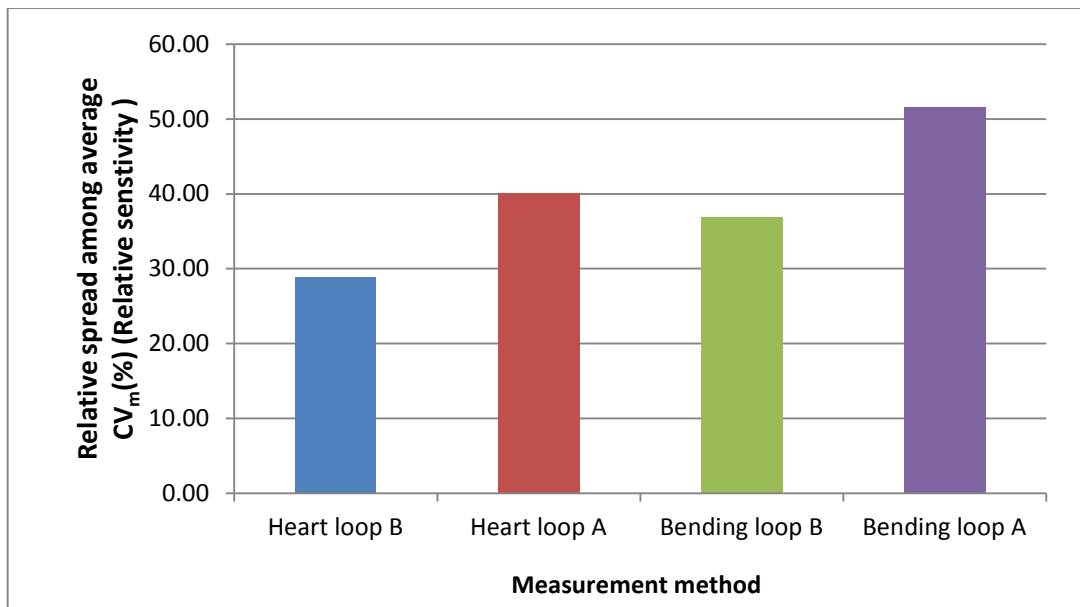
The average  $CV_f$  of the Heart loop and Bending loop methods were calculated and shown in Figure 6.6 (NB the  $CV_f$  is correlated negatively with a method precision). From Figure 6.6 the reproducibility of Heart loop is still better than the Bending loop test which supports the previous comparison. However, both methods' precision is lower by adding the five fabrics (A) than before including them (B).



**Figure 6.6** Heart loop and Bending loop methods' precision

#### 6.7.4 Relative sensitivity $CV_m$

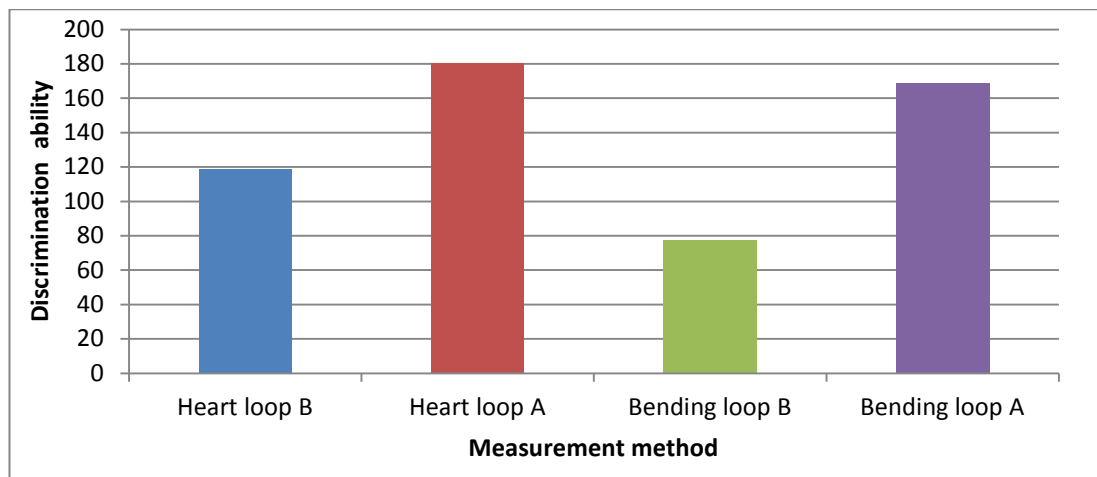
From Figure 6.7 the relative sensitivity increased for both methods by involving the five fabrics K1, K2, W3, W5 and N1. The Bending loop test's relative sensitivity is still higher than the Heart loop test though with a small difference. This means that these two methods are capable of measuring a range of fabrics including medium, limp and stiff fabrics and differentiate between them efficiently.



**Figure 6.7** Relative spread among average  $CV_m$  (Relative sensitivity)

### 6.7.5 Discrimination ability

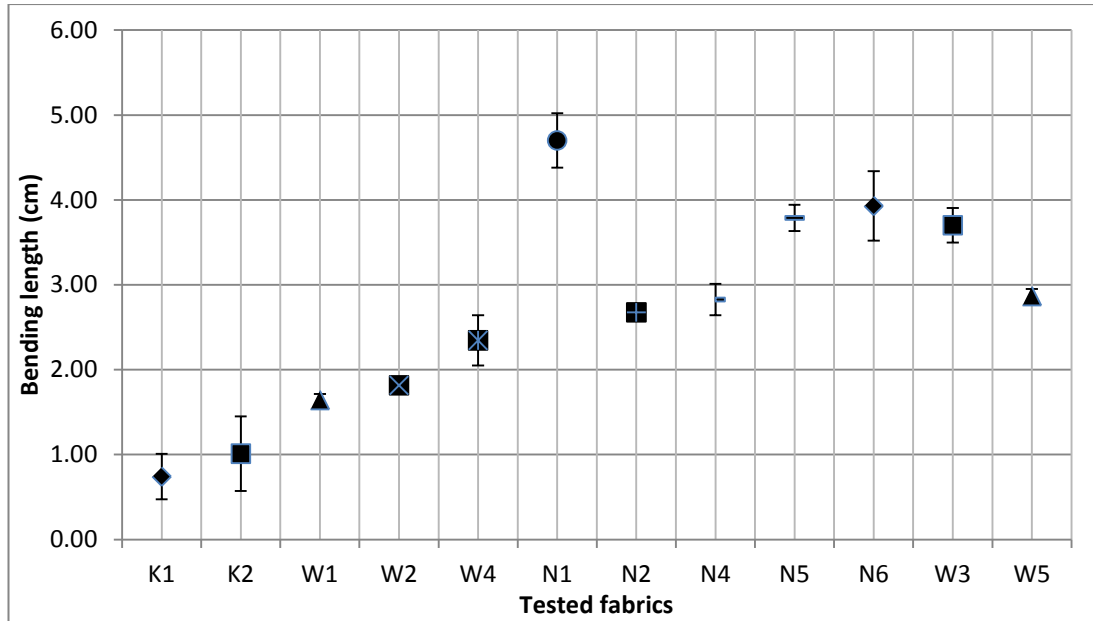
From Figure 6.8, the discrimination ability of both methods increased significantly after including K1, K2, W3, W5 and N1. But, generally there is a slight difference between them before and after including the five fabrics, which means that both methods could discriminate between fabrics with similar levels. However, the Heart loop has slightly higher discrimination ability than the Bending loop test with 180.62 and 168.85 for Heart loop and Bending loop tests respectively. This again supports the previous comparison results.



**Figure 6.8** Discrimination ability of Heart loop and Bending loop tests

### 6.7.6 Variation of *BL* among methods according to fabric stiffness

The average bending length of each fabric from the two methods and the standard error were calculated. From Figure 6.9, there is no correlation between *BL* values and their variation among methods. Nevertheless, high deviation is found at low (as in K2) and high *BL* values (as in N6).



**Figure 6.9** Error in measuring fabrics *BL* stiffness between methods (Heart loop and Bending loop)

### 6.7.7 Summary

It was found that both methods could be used efficiently to measure a range of fabrics involving different stiffness degrees between limp ( $BL = 0.5\text{cm}$ ) and very stiff fabrics ( $BL = 5\text{cm}$ ). The differences are statistically insignificant. But the selection of one of them would be based on other parameters for instance, relative precision, relative sensitivity and Discrimination ability.

Including K1, K2, W3, W5 and N1 increased the two methods' correlation, relative sensitivity and discrimination ability, however, their reproducibility decreased.

The Bending loop test has higher sensitivity than the Heart loop test. Therefore, the Heart loop test was selected to carry out further measurements as mentioned above based on its better precision and discrimination ability than the Bending loop test.

It is evident from the literature that there are different approaches in measuring fabric bending length. One of them is Peirce's approach which is to measure the lengthwise and crosswise of a tested fabric and the geometric mean of the two main directions presents its *BL*. The second approach is to present a fabric's *BL* using the arithmetic mean of the two main directions and this one is applied in the British Standard for measuring fabric bending length and flexural rigidity BS 3356: 1990, and widely used in most of the papers concerned with measuring bending length. The third approach was developed by Cusick in 1950, he calculated the fabrics



bending length using the two main directions and the bias 45° as follow  $(L + C + 2 \text{ bias})/4$  (In this study, it is called “Grand average” G).

It was interesting to investigate the relationship between these approaches with respect to the agreement between them and the correlation strength using an ANOVA test and coefficient of determination between the three groups.

It was found that the calculated F value (0.858) was lower than the tabulated F value for  $p = 0.4$  ( $F = 3.35$ ). So, there is insignificant difference between the approaches.

## **6.8 Measurement of the extensibility**

The FAST 3 extension meter was used to measure the fabric extensibility at three loads 5, 20 and 100 gf/cm in the lengthwise, crosswise and bias 45 directions, 6 strips in each direction. This test was conducted using the FAST 2 bending meter sample.

A tested sample was mounted between two clamps and the extensibility E was measured using 5 gf/cm and then the load was increased on the sample to measure the E at 20 gf/cm and increased again to measure E at 100 gf/cm. The results were read directly from the display in percent. The maximum limit/value of the device is 21.2%.

## **6.9 Results and discussion**

### **6.9.1 Thickness**

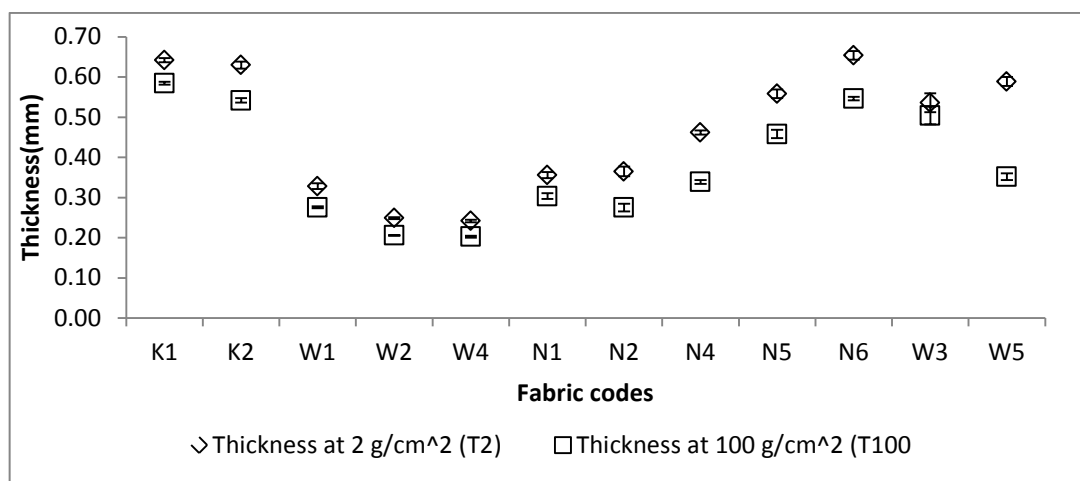
The thickness at 2 and 100 gf/cm<sup>2</sup> and the surface thicknesses of the twelve fabrics were measured. The average values of 6 strips are presented in Figure 6.10 and Figure 6.11.

$T_2$  values are higher than  $T_{100}$ . The fabrics were ordered from the least to highest thickness values of  $T_2$  as follows:  $W_4 < W_2 < W_1 < N_1 < N_2 < N_4 < W_3 < N_5 < W_5 < K_2 < K_1 < N_6$ . Two of the woven fabrics group ( $W_2$  and  $W_4$ ) had the least  $T_2$  values. The knitted fabrics and  $N_6$  (the highest weight nonwoven fabric 170 g/m<sup>2</sup>) had the highest  $T_2$ . There were insignificant differences between conventional fabrics and nonwovens tested.

It was found that there was a positive correlation coefficient of 6.8 between weight and thickness values which is statistically significant at the 5% level. The thickness ( $T_2$ ) of nonwoven fabrics increases with weight. However, two nonwovens,  $N_1$  (not softened) and  $N_4$  (softened), with similar weight,  $N_1$

had lower thickness than N4 with 0.1mm. This means that softening treatment used increased the thickness.

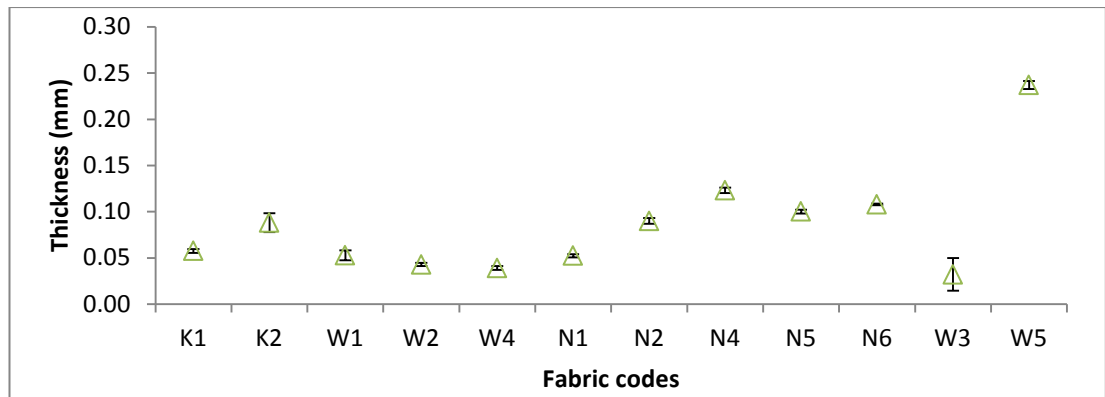
Fabric thickness is dependent on the applied pressure. The relationship between thickness measured under different pressures is “Hardness” (resistance to compression) parameter. This was measured by the difference between thickness values at the two pressures used  $T_2$  and  $T_{100}$  ( which is called in FAST manual surface thickness). Therefore surface thickness were calculated to investigate fabrics measured compression ability and hardness. Variation in surface thickness is a good indicator of variation in fabric handle, appearance and finish, and determines the tolerance of fabric measured.



**Figure 6.10**  $T_2$  and  $T_{100}$  of the tested fabrics

In thickness measurements, there were insignificant differences between conventional and nonwoven fabrics. This did not change in surface thickness measurement. They were ranked as follows:  $W3 < W4 < W2 < N1 < W1 < K1 < K2 < N2 < N5 < N6 < N4 < W5$ .

W5 had the highest surface thickness with significant difference between it and the rest of fabrics tested. Nonwovens (except N1) occupied the highest levels of  $ST$  which means they are the hardest fabrics and able to tolerate variation in thickness with no detectable change in handle or appearance. N1 had low  $ST$  and similar to woven fabrics except W5 which had the highest  $ST$  in the fabrics tested. W3 had the least  $ST$  within the tested fabrics with insignificant difference than W4, W2, N1, W1, K1. The two knitted fabrics had medium  $ST$ . The surface thickness of nonwovens tested increased with weight (their order was as follows  $N2 < N5 < N6$ ). This was not true for N1 and N4 ( $100 \text{ g/m}^2$ ), N1 had the least  $ST$  in the nonwovens however N4 (which had higher thickness than its peer) was the highest.



**Figure 6.11** Surface thickness

### 6.9.2 Extensibility

The fabrics' extensibility at three loads 5, 20 and 100 g/cm,  $E_5$ ,  $E_{20}$  and  $E_{100}$  respectively were measured (six samples in each direction: lengthwise, crosswise and bias  $45^\circ$ ). The arithmetic average values of the three directions were used to investigate the difference/relationship between the fabrics (see Figure 6.12).

From Figure 6.12, the extensibility of all fabrics increased with increased applied load but not at the same rate. The increase in  $E$  is very poor in the nonwoven fabrics compared to the knitted and some woven fabrics (W1, W2, W4), but the discrimination between the nonwovens became more noticeable with increased applied load. However, the difference between the knitted fabrics K1 and K2 specially at  $E_{100}$  was reduced.

The nonwovens, W3 and W5 extensibility is the lowest (at the three loads). The fabrics tested could be characterised in three groups, the least extensible one is the nonwovens, W3 and W5, Knitted fabrics group is the highest, however W1, W2 and W4 is in the middle.

In  $E_{100}$ , one of the knitted fabrics (K1) reached the maximum limit of the extension meter (21.1%), however the most extensible nonwoven fabric (N4) reached 2.4% of the maximum extensibility value.

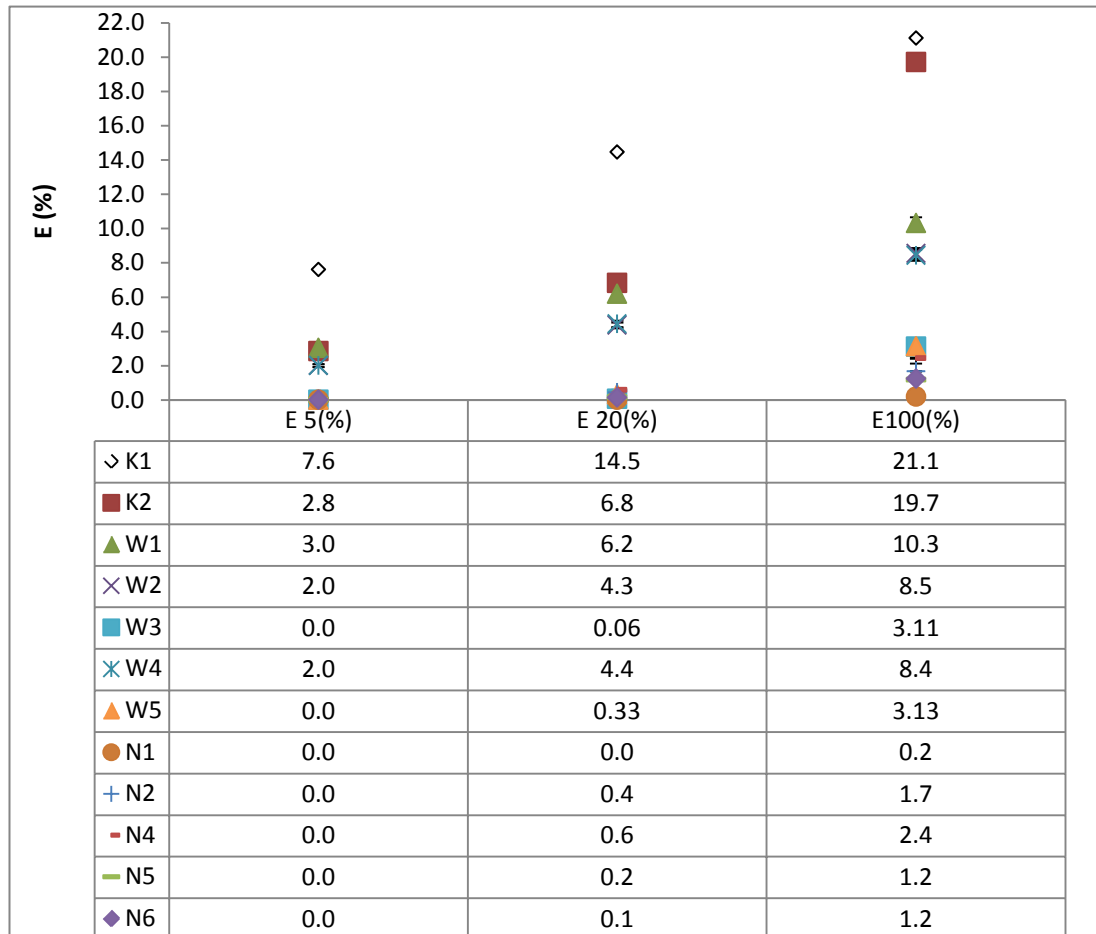
K1 has always the highest  $E$  within the measured fabrics, K2 has similar  $E_5$  and  $E_{20}$  to W1, W2 and W4 (especially W1 which was the most extensible woven fabric) and closer to K1 in terms of  $E_{100}$ .

The group with the least extensible rates (nonwovens, W3 and W5) was inextensible at  $E_5$ . In  $E_{20}$ , W3 and W5 had similar  $E$  to nonwovens (see Figure 6.12), however had higher extensibility rates than them in  $E_{100}$ .

It is clear that the nonwoven fabrics tested had the lowest  $E$  values at the three loads. They were similar to the two woven fabrics tested (W3, W5), but

they had lower extensibility than them in the *E100* test. This shows that nonwovens have lower *E* than conventional fabrics and similar to others at *E5* and *E20*. *E100* test showed the difference between nonwovens and conventional fabrics.

However, the nonwoven fabrics have very low extensibility, they are ranked as follows from the lowest extensibility to the highest-according to *E100*: N1, (N5 and N6), N2 and then N4.



**Figure 6.12** The measured extensibility

The relationships between the extensibility of the measured fabrics in the lengthwise, crosswise and bias direction were studied (see Figure 6.13 to Figure 6.15).

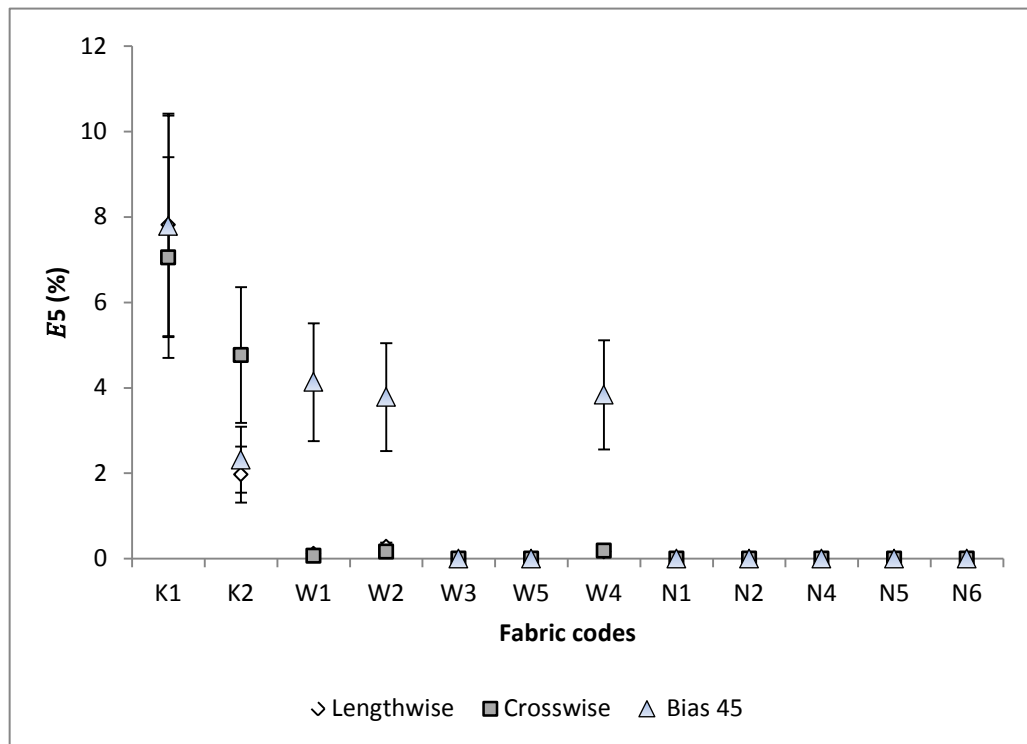
In the knitted fabrics, one of them (K1) has similar *E* for L and C and bias 45° at the three loads. However, K2 has lengthwise extensibility lower than the crosswise extensibility at the three loads. K2 bias 45° extensibility is as low as L at *E5* and *E20*, but similar to the crosswise in *E100*.

In the woven fabrics (W1, W2, W4), the bias direction has higher *E* at the three loads than the two main direction. There is insignificant difference

between the two main directions' E at low loads. In W1 and W2, the lengthwise direction became more extensible than the crosswise direction with increased load, this is significantly observed in W1, while the difference is lower in W2. W4 has similar E in L and C directions.

W3 and W5, the least extensible woven fabrics tested, had similar E in  $E_5$  and  $E_{20}$ , however, the bias direction had significant higher  $E_{100}$  than lengthwise and crosswise.

In Figure 6.13 to Figure 6.15, the nonwovens were virtually inextensible at  $E_5$ . At  $E_{20}$ , their extensibility increased insignificantly. However, they had low extensibility at 100 gf/cm by which directions and fabrics could be discriminated. In the highest rigidity nonwovens (N1, N5 and N6), the three measured directions had similar extensibility, but in N2 and N4 which had lower significant rigidity than the previous group the lengthwise direction was lower than the crosswise and bias 45 directions.



**Figure 6.13** Measured extensibility at 5 gf/cm

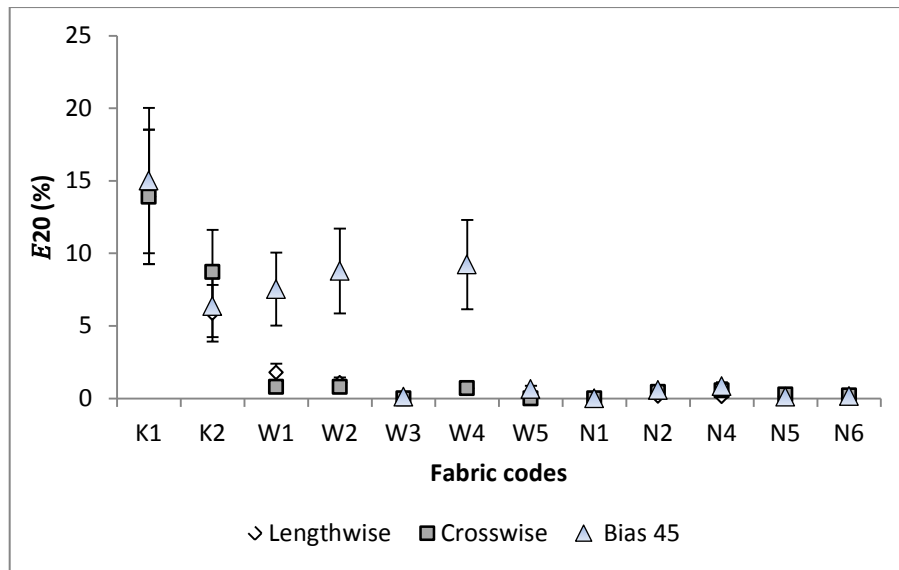


Figure 6.14 Measured extensibility at 20 gf/cm

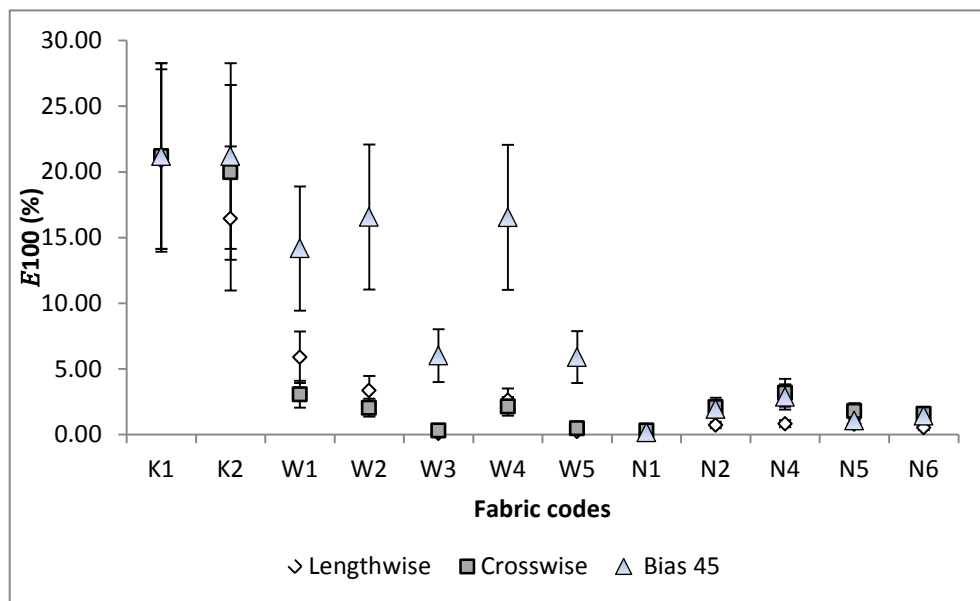


Figure 6.15 Measured extensibility at 100 gf/cm

### 6.9.3 Shear rigidity( $G$ )

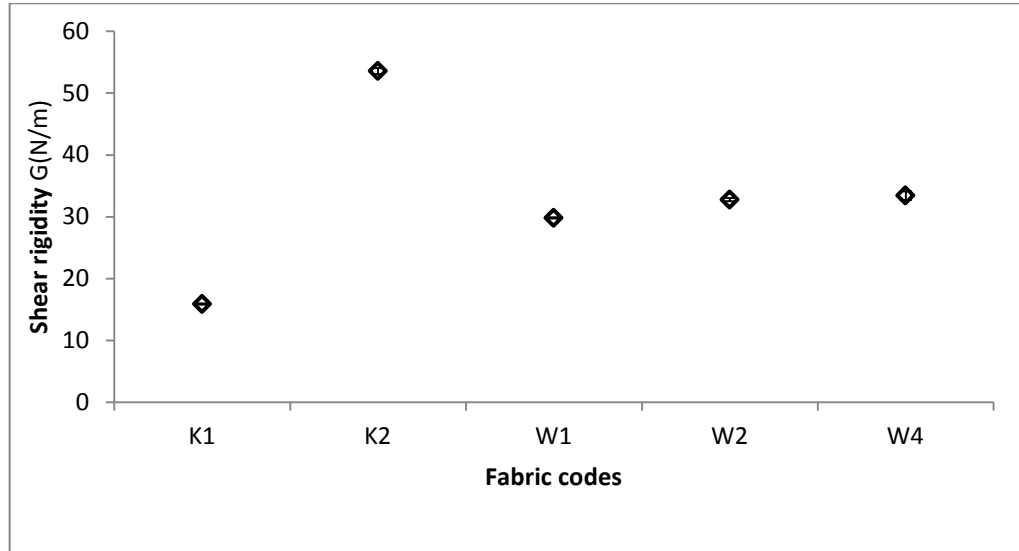
The shear rigidity was calculated using Equation 6.6 (CSIRO 1991).

$$G(\text{N/m}) = 123/\text{EB5} \quad 6.6$$

where: EB5 is the Extensibility at 5 gf/cm in the bias direction.

It is noteworthy that W3, W5 and all the nonwoven fabrics' EB5 was zero which made their shear rigidity virtually infinite. This means that they are very rigid for shear. Therefore, these were not presented in Figure 6.16.

Three woven fabrics measured (W1, W2 and W4) had similar shear rigidity values, W1 is insignificantly lower than W2 and W4. One of the knitted fabrics (K1) is lower than woven fabrics and the other (K2) is higher than the group of (W1, W2 and W4) (see Figure 6.16).



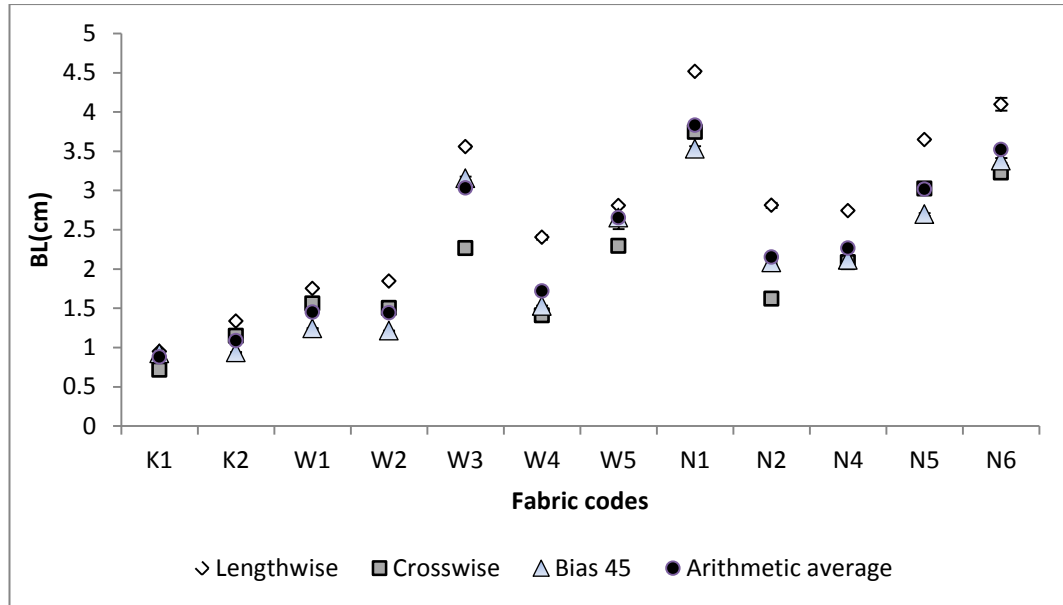
**Figure 6.16** Shear rigidity

#### 6.9.4 Bending length

The bending lengths of the tested fabrics were measured using the heart loop test. Six strips were tested from each fabric in each direction (lengthwise, crosswise and bias 45) to study the relationship between them. The arithmetic average *BL* of each fabric was calculated and used to investigate the relationship between the tested fabrics.

From Figure 6.17, the knitted fabrics have the lowest *BL*, the woven fabrics (W1, W2 and W4) had insignificantly higher *BL* than them.

With regard to the nonwoven fabrics, all the nonwoven fabrics have *BL* values higher than some conventional fabrics tested, which were ranked as follows:  $K1 < K2 < W2 < W1 < W4$ . The rest of the measured fabrics were ranked as follows from the lowest *BL* to the highest:  $N2 < N4 < W5 < N5 < W3 < N6 < N1$ . This ranking shows that nonwovens (N2 and N4) had lower *BL* than two woven fabrics W3 and W5. However W3 had *BL* higher than N2, N4 and N5.



**Figure 6.17** Measured bending length

N1 unsoftened fabric (the only unsoftened fabric within the nonwoven fabrics group 100 g/m<sup>2</sup>) had the highest *BL* followed by N6 (170 g/m<sup>2</sup> softened) and then N5 (130 g/m<sup>2</sup>) softened. N2 and N4 are the lowest within the nonwovens group with insignificantly higher *BL* than the woven fabrics. The lightest nonwoven N2 fabric had the lowest bending length value. It is interesting to see that two fabrics (N1 and N4) with the same weight, but the softened one had a much lower *BL* than the unsoftened one.

The lengthwise results in all the tested fabrics had *BL* values higher than both crosswise and bias 45° (except K1, the lowest *BL*, as all the three directions had similar values). K1, K2, W1 and W2 had insignificant difference between lengthwise and crosswise. The bias 45° is either as low as the crosswise or lower in the tested fabrics (except in N2 and W3, as the bias 45° has *BL* values higher than the crosswise).

### 6.9.5 Bending rigidity (BR)

The bending rigidity of the tested fabrics was calculated using Equation 6.7 (CSIRO 1991) in the three directions L, C, bias 45° and their arithmetic average was computed (see Figure 6.18):

$$BR(\mu\text{Nm}) = W(\text{g/m}^2) \times BL^3(\text{mm}) \times 9.807 \times 10^{-6} \quad 6.7$$

The bending rigidity of the knitted and three woven (W1, W2 and W4) fabrics is low compared to the nonwovens, W3 and W5. N2 and N4, the lowest *BR* in the nonwovens group, had insignificantly higher *BR* than (W1, W2 and W4). The rest of the fabrics tested had significantly higher *BR* than the previous group. These were ranked as follows from the lowest *BR* to the highest W5 < N5 < N1 < W3 < N6. The similarity between nonwovens and some

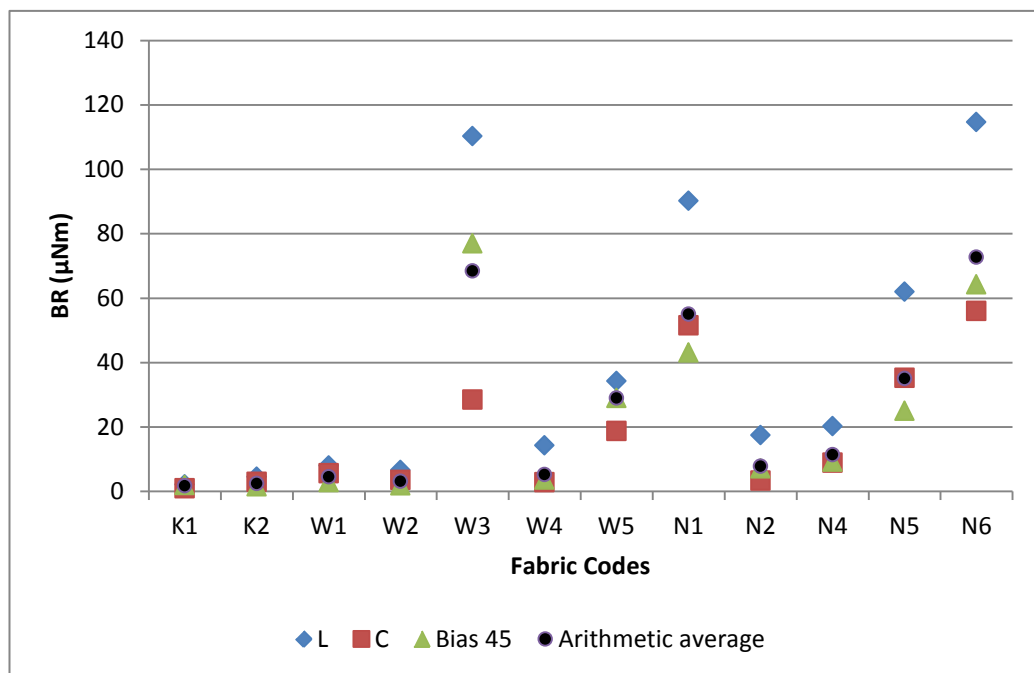


conventional fabrics' *BR* is clearly seen. Some nonwovens had lower *BR* than conventional fabrics (namely W3 and W5).

Two of the nonwoven fabrics - N2 and N4 - had *BR* values similar to the conventional fabrics. N5 has a higher *BR* followed by N1, and N6 had the highest *BR*.

In the nonwovens, the difference in *BR* between the measured directions was higher than the conventional fabrics. In general, the lengthwise L tests had the highest *BR*, however the crosswise C and the bias 45° were close to each other. N1 and N6 had the highest difference between L and other directions, N5 had lower difference and N2 and N4 had the lowest difference.

K1, K2, W1 and W2 had similar *BR* for the three directions measured. In the rest of the fabrics the L had *BR* higher than the other two directions (crosswise and bias). In N1, N2, N4, N5, N6, W4 and W5, Bias and crosswise *BR* are similar or very close to each other. W3 had Bias *BR* higher significantly than the crosswise.



**Figure 6.18** The bending rigidity of the tested fabrics

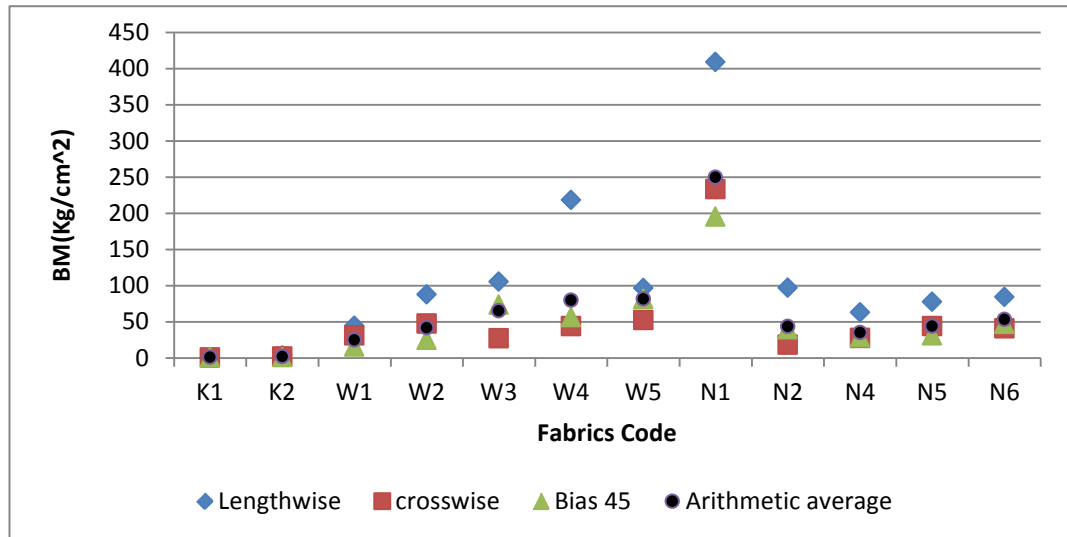
### 6.9.6 Bending modulus

The bending modulus of the tested fabrics were calculated in the three directions L, C, bias 45° and their arithmetic average (see Figure 6.19) using Equation 6.8 (CSIRO 1991):

$$BM(\text{Kg}/\text{cm}^2) = 12 \times BL^3\text{mm} \times W \text{g}/\text{m}^2 \times 10^{-7}/T100^3\text{mm} \quad 6.8$$

The tested knitted fabrics had the lowest *BM* with similar values in the three directions. Generally, the woven and nonwoven fabrics have similar *BM*, except N1 as it had significantly the highest *BM* within all tested fabrics.

In the woven and nonwoven fabrics, the lengthwise *BM* is higher than the C and bias 45°. N1 and W4 have highest significant difference between L and other directions of measurement. Generally, C and the bias have approximately similar *BM* behaviour.



**Figure 6.19** The bending modulus of the tested fabrics

### 6.9.7 Formability(*FR*)

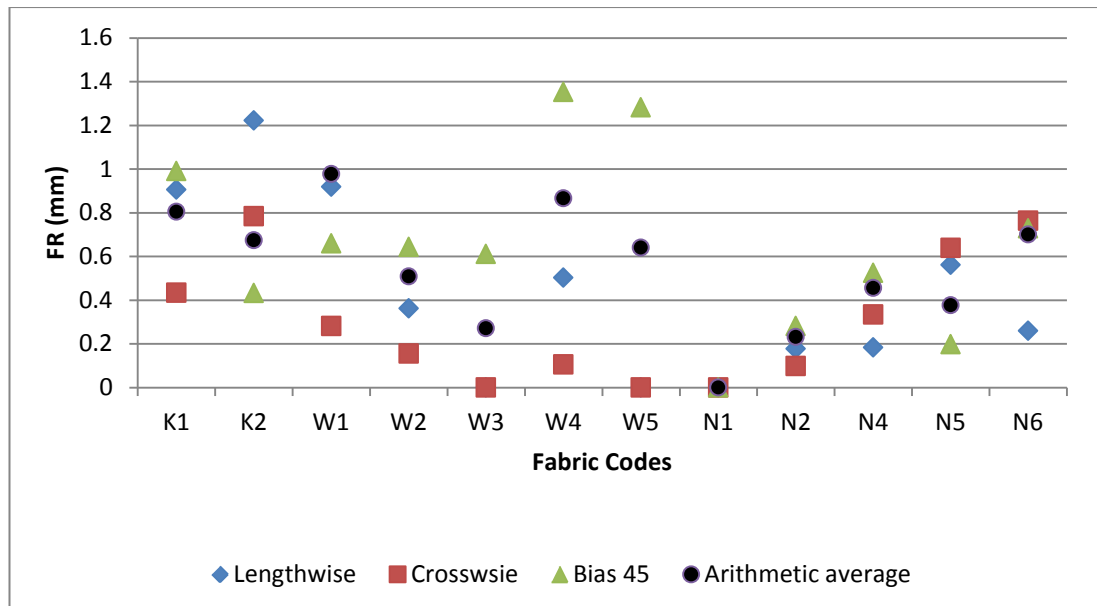
The formability of the tested fabrics was calculated in the three directions L, C, bias 45 and their average using Equation 6.9 (CSIRO 1991):

$$FR (mm^2) = BR (\mu Nm) \times (E20 - E5)\% / 14.7 \quad 6.9$$

From Figure 6.20, generally, conventional tested fabrics had formability higher than nonwovens (except N6). N6 is the highest nonwoven fabric *FR* (similar to conventional fabrics). N4 and N5 have insignificantly lower *FR* than conventional fabrics and N6, N2 is lower. N1 is the only fabric which has zero formability. W3 had low formability as most of the nonwovens tested.

In the Knitted and woven (except W3 and W5) fabrics the L has higher *FR* than C, however the bias 45° was different between fabrics with regard to L and C.

In the nonwoven fabrics, L has lower *FR* than C except in N2 and the bias direction had different behaviour with regard to L and C from one fabric to another.



**Figure 6.20** The formability of the tested fabrics

### 6.10 Summary

The structure and low stress mechanical properties of the tested fabrics range were measured to be identified. Nonwoven, woven and knitted fabrics already used for apparel making were included. With regard to the most important parameters which affected and correlated with drape (the focus of the study), were bending length and shear rigidity.

It was found that the tested nonwoven fabrics have high bending length which was sometimes similar to conventional fabrics. The nonwoven fabrics were found to have virtually unlimited values of shear rigidity which was the case in some conventional fabrics tested.

The nonwoven fabrics' bending rigidity is also similar to conventional fabrics tested. The bending modulus is similar for all the fabrics except one fabric (N1 unsoftened 100 g/m<sup>2</sup>).

The nonwoven fabrics' extensibility is far less than conventional fabrics in *E*100. However the range of their thickness is similar to the conventional fabrics and sometimes less than knitted fabrics.

Findings of this chapter show that there was similarity in the mechanical behaviour of both nonwovens and some conventional fabrics (already used in apparel making). This resemblance between some conventional and nonwoven fabrics with regard to mechanical properties related to fabric drapeability indicates that the nonwoven fabrics would have similar drape behaviour to conventional fabrics.

## **Chapter 7**

### **Fabric drape measurement**

#### **7.1 Introduction**

The drape of nonwoven garments is the main interest of this research. It was found from the literature review that fabric drape is related to garment drape. In this chapter, fabric drape was studied using drape parameters including: drape coefficient, drape profile and number of nodes.

Two methods were used in this study, the manual (cut and weigh) and digital (based on analysing the draped fabric images) methods. A Cusick drapemeter was the apparatus used in this study and the British Standard, Test methods for nonwovens Part 9: Determination of drapeability including drape coefficient (BS EN ISO9073-9:2008) was applied.

#### **7.2 Experimental**

##### **7.2.1 Apparatus**

In this study, the following apparatus and tools were used:

**A drapemeter:** Cusick's drapemeter was used.

**Templates:** Circular templates of 30 and 36 cm diameter were used to cut the tested samples and locate the sample's centre.

**Paper rings:** Translucent annular paper rings of 30 and 36 cm diameter were used in both test methods (cut and weigh, and digital). In the digital method a paper ring was used as a surface on which the shadow of the draped fabrics were cast.

**Camera and tripod:** A digital camera was used to capture images of the shadow of the draped fabric in the application of the digital method. This camera was connected to a PC (see Figure 7.1).

**Personal computer and software:** A personal computer was used in the digital method to adjust and process the images taken for the draped samples using image processing software (Adobe Photoshop CS2).



**Figure 7.1** Cusick's drapemeter and tripod used in fabric drape measurement

## **7.2.2 Samples**

In this study, fabrics with different stiffness values were compared with each other, therefore 30cm diameter specimens were used in this investigation for all tests not only for an initial test as stated in the applied British Standard. A further study using 36cm diameter samples was carried out to investigate the drapability of the nonwoven fabrics and two stiff woven fabrics (W3 and W5).

Three samples were cut from fabric free from creases, at least 5 cm were left between a sample and a selvedge. The samples were conditioned in a standard atmosphere before testing as specified in BS 1051, i.e. a relative humidity of  $65 \pm 2\%$  and a temperature of  $20 \pm 2$  °C.

## **7.2.3 Test procedure**

### **7.2.3.1 General**

According to the applied British Standard (BS EN ISO9073-9:2008), the Cusick drapemeter was first calibrated to ensure that the light source is at the focus of the parabolic mirror in order to ensure that the shadow of a tested fabric was cast centrally on the paper ring. A paper ring was temporarily fixed on the drapemeter's lid centrally above the supporting disc. The lid with the paper ring was opened to mount the sample. The tested

sample was mounted horizontally on both the supporting and the outer annular discs (as they were at one level when the apparatus lid is opened) and its centre was passed through the pin which is located centrally on the supporting disc. The supported part of the sample was sandwiched between two discs (the supporting disc and another one with the same diameter 18cm). Closing the lid let the annular disc move downwards to allow the sample to hang and drape under its own weight.

A translucent paper ring was used to allow the shadow of the draped sample to be cast on it. The percentage of the paper ring covered by the fabric shadow is the drape coefficient. The technique of calculating the shadow ratio differs according to the method used (digital or manual).

The cut and weigh method was applied at first as the digital method's equipment was not available at the beginning of the study. The digital method was applied as it was important to have images for the draped samples to compare them with the draped garment images which were studied later in this research.

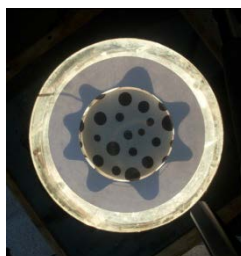
### **7.2.3.2 Manual (cut and weigh) method**

In this method, the shadow of sample tested was traced on a paper ring. The paper weight was measured before and after cutting around the shadow as the drape coefficient is the ratio between these two weights.

### **7.2.3.3 Digital method**

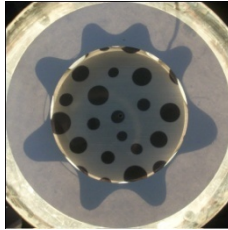
In this method, a digital camera was set above the drapemeter by means of a tripod to capture stable still images of draped fabric. The following steps were applied to edit the image in order to obtain the final image from which the digital drape coefficients using 30 and 36cm diameter paper rings and samples; DC 30 and DC36 respectively, were measured:

1. A draped fabric was captured from above the drapemeter using a digital camera (Figure 7.2).



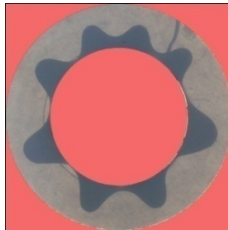
**Figure 7.2** Original image for a tested sample

- Each image was processed using image processing software (Adobe Photoshop CS2). They were rotated to align the lengthwise direction of the fabric with the vertical axis to make it easier for studying the nodes' orientation with relation to the lengthwise and crosswise directions (drape profile). The image was cropped at the edges of the paper ring. Its dimensions were calibrated to ensure constant measurements and calculations of the drape coefficient in different tests (see Figure 7.3).



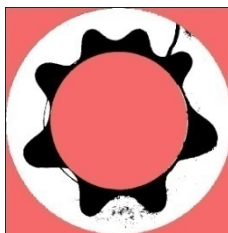
**Figure 7.3** A calibrated image for a draped sample

- Since, only the paper ring shadow was needed, as the existence of any other shadows is not required, the inverse of the paper ring was selected and filled with one colour to remove parts outside the paper ring and to prepare the image for the following step (see Figure 7.4).



**Figure 7.4** The inverse of the paper ring is filled with one colour

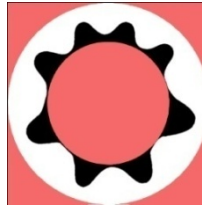
- The shadow on the ring was thresholded to obtain a binary image of the shadow (see Figure 7.5).



**Figure 7.5** A thresholded shadow

- The image was cleaned to remove the not required parts/pixels. This image was used to count the shadow area's number of pixels. The shadow area was selected using the magic wand tool and the histogram window displayed the number of pixels occupying the fabric's shadow. The number

of pixels of the whole ring was measured using the same technique (see Figure 7.6).



**Figure 7.6** Final image

In both methods (manual - digital), each sample was tested with its face upwards and turned upside down to measure its reverse. These two measurements were repeated twice to obtain 3 face and 3 back shadows for each sample. Nine face and nine back shadows were obtained for three different samples in the digital method. However, only two samples were measured in the manual test. The drape measurement was carried out using 30 cm diameter samples and paper rings (D30) to study the drape of the whole range of the fabrics tested (woven, knitted and nonwoven). However another study for only the group of nonwovens using 36cm diameter sample (D36) was conducted.

#### **7.2.3.4 Calculation of drape coefficient**

The drape coefficient (DC) was calculated using Equation 7.1:

$$DC = \frac{M2 \times 100}{M1} \quad 7.1$$

where: M1 is the original paper ring mass, M2 is the shaded area mass, the mass was expressed in grams (weight unit) in the manual (cut and weigh) method and alternatively by the number of pixels in the digital method.

### **7.3 Results and discussion**

#### **7.3.1 Drape measurement of the whole fabrics range (D30)**

The manual and digital drape tests were carried out according to the steps mentioned above in section 7.2.3.3. The following parameters were calculated and studied.

##### **7.3.1.1 Drape coefficient (DC30)**

The face, back and their average (grand average) drape coefficient DC30 values of the fabrics tested are shown in Figure 7.7. Generally the twelve fabrics tested seems to be categorised into two groups K1, K2, W1, W2, and W4 and the other group including W3, W5, and nonwovens. Their DC ranges



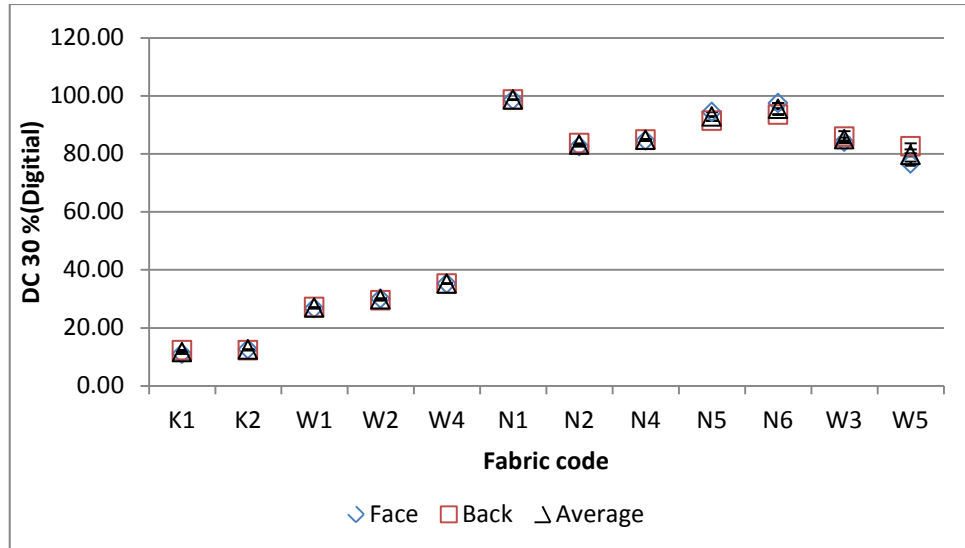
were 11.65 to 35.27% and 79.63 to 98.66% respectively. Therefore, there is a group of fabric with good drapeability (GD) and another one with low drapeability (LD).

From Figure 7.7, the GD fabrics group could be sub grouped into two groups. The knitted fabrics group which had the lowest DC values and followed by the group of three woven fabrics (W1, W2 and W4) which have similar DC30 values.

With respect to the LD fabrics group, three sub groups existed. These were  $W5_{DC} < N2_{DC} < N4_{DC} < W3_{DC}$ . The second group was  $(N5_{DC} < N6_{DC})$ , however the third group included only N1. From these subgroups, two nonwoven fabrics tested ( $N2 < N4$ ) had lower DC30 than one woven fabric W3. W5 had insignificant lower DC30 than N2 (the highest drapeable nonwoven) with around 3%. Therefore, it was found that although nonwovens have higher DC (lower drapeability) than some types of conventional fabrics, they could have similar drapeability to some conventional fabrics.

N2 ( $80 \text{ g/m}^2$ ) and N4 ( $100 \text{ g/m}^2$  softened) are the most drapeable within the nonwovens group. N5 and N6 have lower drapeability than (N2 and N4) and N1 is the lowest in drapeability. The difference between N1 and N4 in DC30 (which have the same weight with different treatments, the first is not softened and the second is softened) shows the effect of the softening treatment on the fabric drapeability. As the softened one is more drapeable than the unsoftened.

The relationship between the fabric weight and drapeability of nonwoven fabrics is noted that DC30 increased with the fabrics' weight with the exception of N1 ( $100 \text{ g/m}^2$ ) the only unsoftened fabric between the five nonwoven tested fabrics. Its DC30 reached around 99% which means that it is a very stiff barely drapeable fabric. This fabric is the least drapeable nonwoven fabric.



**Figure 7.7** The drape coefficient measured using 30cm diameter by the digital method

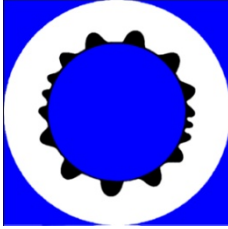
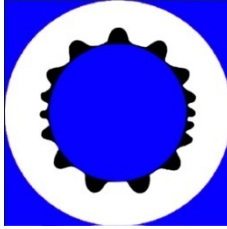
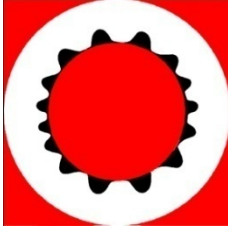
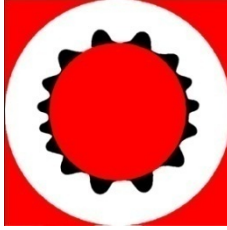
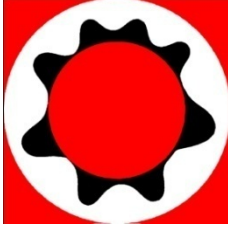
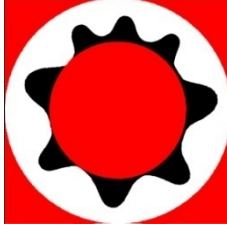
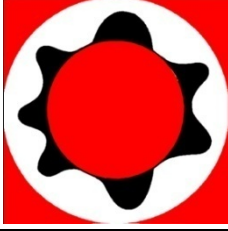
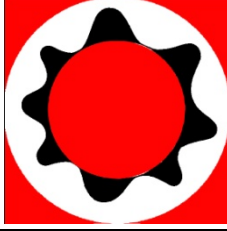
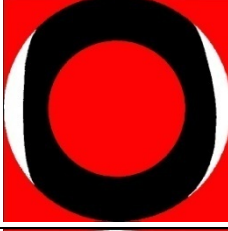
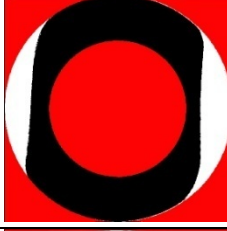


### 7.3.1.2 Correlation between manual and digital methods

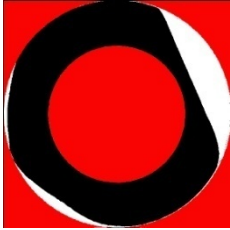
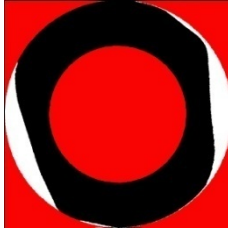
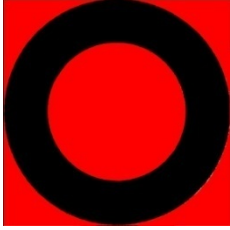
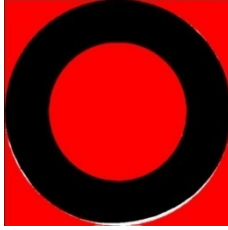
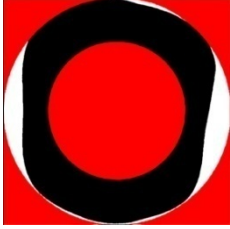

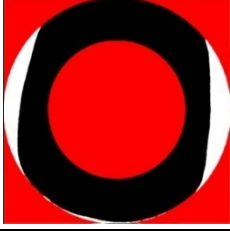
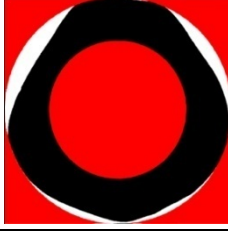
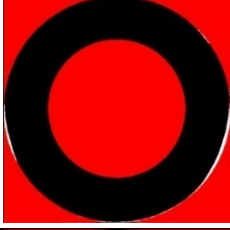
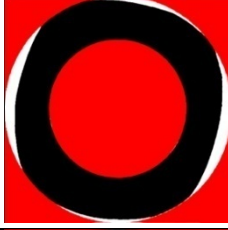
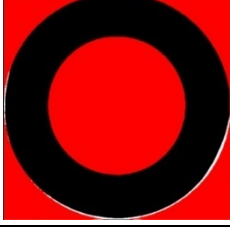
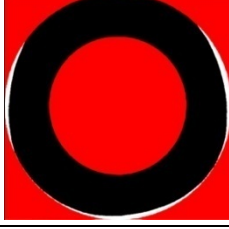
The correlation coefficient between the two methods (manual – digital) was calculated and found to be  $r = 0.82$ ,  $p < 0.001$  which is a very strong significant correlation. This result supported the previous research results which showed high correlation between the two methods and the validity of using the digital method in measuring fabric drape (Vangheluwe and Kiekens 1993, Ruckman, Cheng and Murray 1998).

### 7.3.1.3 Nodes/Folds (N30)

One definition of fabric drapeability is its ability to make nodes/folds. The literature review showed that there is a strong negative correlation between the number of nodes and the drape coefficient. A low rigidity area in a fabric has higher ability to form a node than a more high rigidity area. In this study, the node number, orientation and size/severity of the fabric tested range were studied. Table 7.1 lists randomly selected images for the face and back of the tested fabrics in D30.

**Table 7.1** Randomly selected images for the face and back of the tested fabrics in D30

	Sample Image	
	Face	Back
K1		
K2		
W1		
W2		
W3		
W4		

	Sample Image	
	Face	Back
W5		
N1		
N2		
N4		
N5		
N6		

7.3.1.3.1 Number of nodes (NN30)

Figure 7.8 presents the 12 fabrics' number of nodes measured in D30. Nine images were obtained for the D30 measurement using the digital method for each face per fabric. The obtained NN is the average number of nodes from the eighteen images.

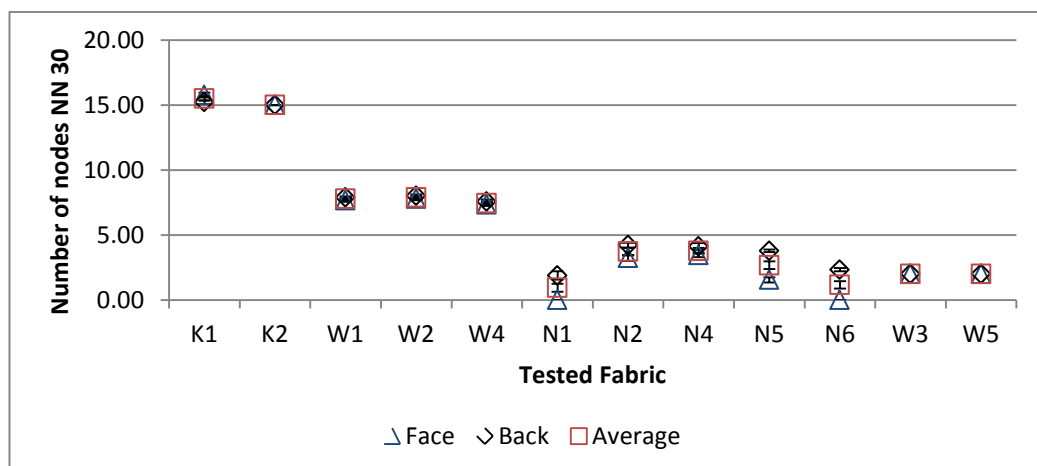
Generally, the twelve fabrics measured seem to be characterised in three groups according to the number of nodes generated with considerable difference between them. The knitted fabrics have around 15 nodes, the woven fabrics (W1, W2 and W4) have around 8 nodes and the nonwovens and W3 and W5 have a maximum of around 3 nodes. The last group is the least drapable (LD) fabrics.

The knitted fabrics (K1 and K2) show the highest number of nodes NN, followed by the three woven fabrics (W1, W2 and W4) which have approximately half the knitted fabrics' NN.

The nonwoven fabrics, W3 and W5 have the lowest number of nodes compared with the other two groups. N2 and N4 have the highest number of nodes within the low drapable (LD) fabrics group, followed by N5. It is evident that N2, N4 and N5 had higher NN 30 than W3 and W5 (woven fabrics) which indicates the higher drape of some nonwovens than some conventional fabrics. N1 is the lowest NN and N6's NN is not significantly higher than N1.

It is important to note that fabrics N1, N6 and also N5 do not seem to make easily discriminated nodes as they are barely detectable in some images.

It is noteworthy that although the nonwovens generally and especially N2, N4 and N5 have an approximately similar number of nodes, their DC30 and drape profiles show differences in their drapability. This means that NN is not a sufficient parameter to evaluate fabric drapability and other parameters such as the drape coefficient and node's size are important. The number of nodes parameters discriminated between the knitted fabrics and the three woven fabrics (W1, W2 and W4) more obviously than DC parameter. Therefore, the two parameters (DC and NN) are important for discrimination between fabrics' drapability.



**Figure 7.8** The number of nodes of the tested fabrics in the D30 test

#### 7.3.1.3.2 Correlation between number of nodes and drupe coefficient

The correlation between the number of nodes NN and the drupe coefficient was calculated. There was found a negative Correlation Coefficient  $r = -0.9$  between them, the number of nodes increased as DC30 went down. A strong correlation with  $R^2=0.86$  was found, which supports the previous drupe research results.

#### 7.3.1.3.3 Nodes' severity/size (NS30)

Nodes' severity was assessed visually by the researcher. A node with large wavelength was considered a big node and vice versa. The difference between the node severity/size in the three groups of fabrics is noted and the knitted fabrics have small nodes compared with the other two groups. The two measured knitted fabrics have similar node sizes.

The woven fabrics (W1, W2, W4) have approximately medium node sizes. Their node sizes are in between the knitted, and (nonwoven, W3 and W5) fabric groups but more resemble the knitted fabrics than the nonwovens, W3 and W5.

The nonwovens, W3 and W5 fabrics have the largest node sizes (in other words they have long wavelength with short wave amplitude). Generally, N1, N5 and N6 have insignificant or nonexistent nodes. However, N2, N4, W3 and W5 have similar large nodes.

#### 7.3.1.3.4 Nodes' orientation (NO30)

Nodes' orientation with respect their distribution around the lengthwise and crosswise directions was assessed visually by the researcher. The two knitted fabrics tested have similar node orientation and distribution, the face and back drupe profiles are similar also. However, smaller nodes are located in the crosswise direction than lengthwise direction.

There is similarity between the three tested fabrics (W1, W2 and W4) and between their face and back as well. The nodes are approximately regularly distributed around the periphery of the tested samples.

In the low drupeable fabrics group (nonwovens, W3 and W5), N2, N4, W3 and W5 include considerable nodes in the lengthwise direction

N1, N5 and N6 do not seem to generate significant nodes as N2, N4, W3 and W5 which means they are not considered to produce nodes but sometimes protrude in the lengthwise direction.

### **7.3.2 Drapability of nonwoven fabrics (D36)**

The DC30 of 3 fabrics from the group of 5 nonwoven fabrics and one woven fabric (W3) measured were higher than 85% (the lower limit to carry out further D36 test as stated in the applied British Standard) and three fabrics from the low drapability fabrics group W5, N2 and N4 had DC30 of 79.63, 83.12 and 84.78% respectively.

A D36 test was conducted for the low drape fabrics group. W5, N2 and N4 were tested although their DC30 is below the maximum limit as it was not extremely low. This test provided a more obvious representation for the nonwovens with respect to their drape behaviour than using the 30 cm diameter sample and paper ring (D30). Comparisons between results from D30 and D36 tests/measurements including the drape coefficient, nodes' number, size and orientation were carried out to investigate the difference between tests.

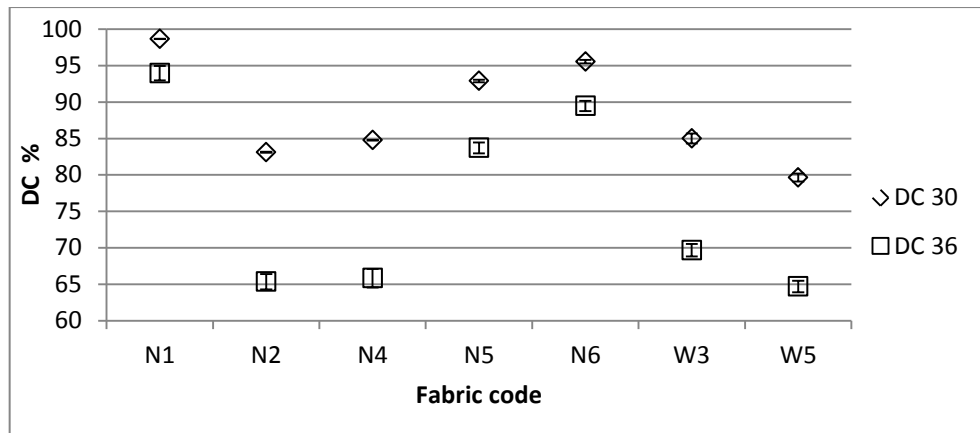
#### **7.3.2.1 Drape coefficient (DC36)**

Figure 7.9 shows the grand average (average face + back) drape coefficients DC36 and DC30 of the seven low drape fabrics. Generally, DC36 values are lower than DC30. Moreover, differences between the fabrics are higher (more significant) in DC36 which supports the purpose of using a sample and paper ring with 36 cm diameter (larger than the one used for DC30) in testing low drape fabrics.

From Figure 7.9, N1 is the least drapable fabric with the highest approximately similar values of DC30 and DC36, which means that larger samples did not affect the results. N6 and N5 had higher drapability than N1, followed by W3, N4 and N2. W5 had the highest drapability in terms of lowest DC36 and DC30.

The difference between the fabrics measured in D36 is more obvious than D30. This means that D36 discriminated between nonwoven fabrics more significantly than D30 and this increased with low DC nonwoven values.

Again, the similarity between nonwoven and woven (W3 and W5) fabrics in terms of DC36 values supports the possibility of having nonwoven fabrics with similar drape to conventional fabrics. Some nonwovens could have better drape than conventional fabrics.



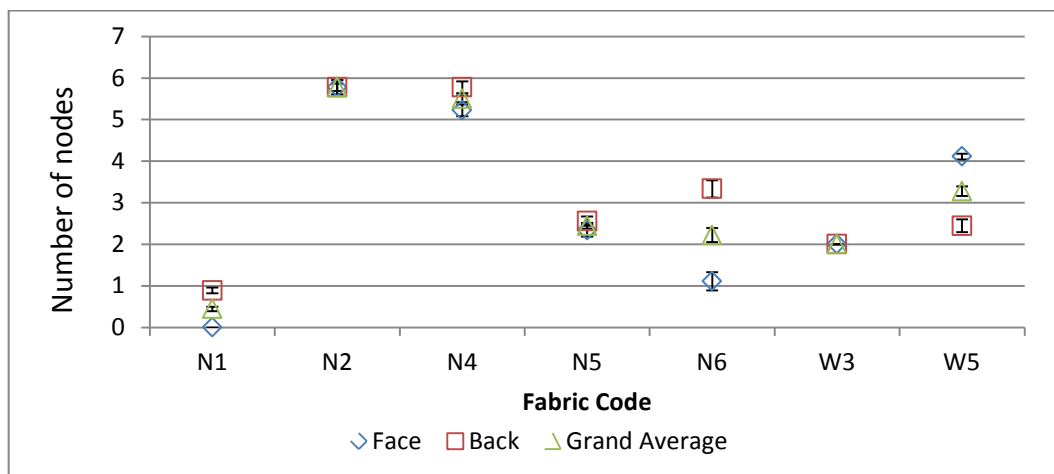
**Figure 7.9** The drape coefficient **DC30** and **DC36** of nonwoven fabrics

### 7.3.2.2 Nodes

The node number, size and orientation in D36 were analysed and compared with D30 results.

#### 7.3.2.2.1 Number of nodes (NN)

Figure 7.10 shows the number of nodes from the D36 test. The low drupe fabrics tested are categorised as follows from the highest NN, (N2 and N4), (W5, N5, N6 and W3) and then N1 has the lowest NN. N2, N5 and W3 have similar NN for the face and back. In N1, N4 and N6 the face has lower NN than the back, however the difference between the face and back is more significant in N6. W5 face has more NN than the back, which means it has high drupeability than the back. NN results from D36 support the obtained outcome from DC30 measurements and indicate that the nonwoven fabrics' drupeability ranking (as the number of nodes) correlated negatively with the drupe coefficient.

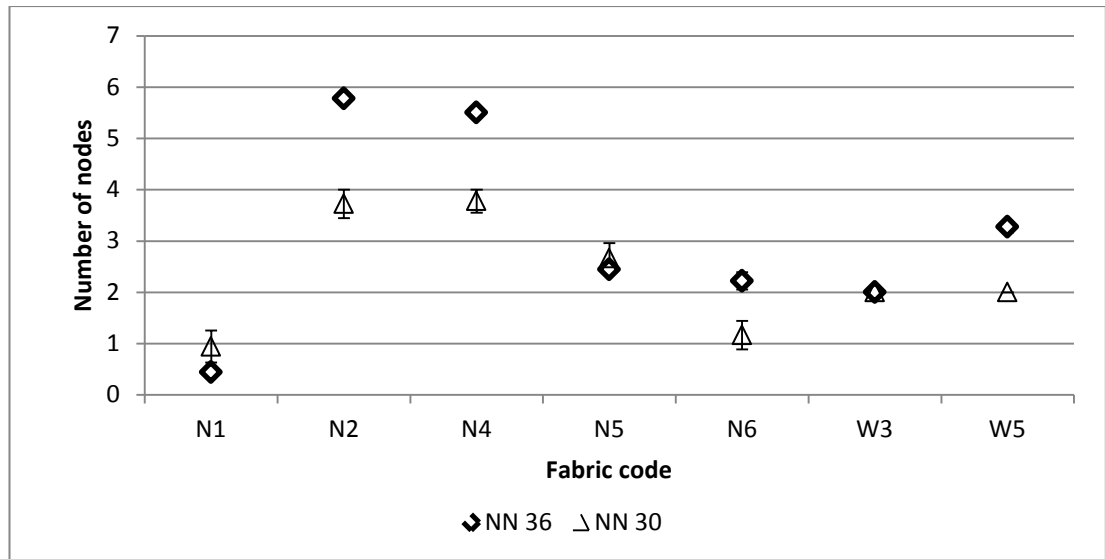


**Figure 7.10** Number of nodes from D36



The average number of nodes from D30 and D36 were calculated and presented in Figure 7.11. The NN increased for N2, N4, N6 and W5 in D36. N1 and N5 approximately maintained their number of nodes. NN was the same for W3 in both tests D30 and D36.

Larger sample size increased the number of nodes for most fabrics tested and kept the same for few fabrics. N1, the least drapeable fabric in respect of its number of nodes, had lower NN 36 than NN30, this would be due to the increased stiffness of the sample tested.



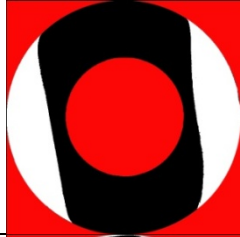











**Figure 7.11** Number of nodes from D30 and D36



#### 7.3.2.2.2 Node severity/size (NS)

Comparisons between low drape fabric images from D30 and D36 show that N1 images are approximately similar in both tests with approximately no nodes. N5 and N6 have smaller nodes (shorter wavelength and longer wave amplitude) in D36 than D30, which makes their images appear to have more distinct nodes. From Table 7.1 and Table 7.2, the most significantly different images are of N2, N4, W3 and W5, as they have significantly smaller nodes in D36 than D30. Again, N2 and N4 have similar node sizes in D36. N5 and N6 are alike as well and there are slightly more significant and smaller nodes in D36 than D30.

Within the low drape fabrics group, N2 and N4 have the smallest nodes which would make them approximately similar to the woven fabrics. However, W3, W5, N5 and N6 have larger nodes than N2 and N4, and N1 does not really generate nodes.

**Table 7.2** Randomly selected images for the face and back of the tested fabrics in D36

	Sample Image	
	Face	Back
W3		
W5		
N1		
N2		
N4		
N5		

	Sample Image	
	Face	Back
N6		

#### 7.3.2.2.3 Drape profile/ Node orientation

It is noted that the most significant difference between D30 and D36 is in W3, N5, N2 and N4 fabric images. D36 images of N2 and N4 have more nodes than D30 and they are generally in the lengthwise (machine direction). W3 and W5 have smaller nodes (two nodes, one at each end of the lengthwise direction).

In D30, N1, N5 and N6 have similar drape profiles, however they are different in D36 as N1 maintained its D30 profile with approximately no nodes. However, N5 and N6 have different D36 images with insignificant differences between D30 and D36 images. They are generally inclined to protrude in the lengthwise direction and in some images in the crosswise direction. It is also noted in the drape profiles that each pair of the following are similar W3, W5 and N2, N4 and N5, N6.

### 7.3.3 Control chart of fabric's drapeability using their mechanical properties

(The relationship between fabric drape coefficients and their mechanical properties)

The measured mechanical properties of the tested fabrics in Chapter 6 and their drape coefficient values are presented in Figure 7.12-Figure 7.15. These charts show the relationships between weight, thickness, extensibility, bending length, rigidity and modulus, formability and the drape coefficient of the fabrics tested. The relationship between these properties and the shear rigidity is presented for knitted fabrics in Figure 7.12. In Figure 7.13, the shear rigidity of W3 and W5 are not presented as they have almost infinite shear rigidity. All nonwovens showed almost infinite shear rigidity, therefore they were not presented in Figure 7.14.

Figure 7.12, Figure 7.13 and Figure 7.14 present the measured mechanical properties and drape coefficient of the knitted, woven and nonwoven fabrics respectively. In Figure 7.15, the conventional fabrics' (knitted and woven) maximum and minimum values of the measured mechanical properties (except the shear rigidity) are determined and connected to make a shaded

area. This shaded area shows the limitations of their measured properties and would help identify the difference between nonwoven and conventional fabrics in terms of physical and mechanical properties and the drape coefficient. Only shear rigidity limitations were presented using a line between the highest and least values obtained as two conventional fabrics (W3 and W5) had almost infinite shear rigidity. This made the comparison between all fabrics shear rigidity difficult.

The conventional fabrics have similar or higher weights than the nonwoven fabrics, as one of the nonwovens (N2) has lower weight than the lowest conventional fabric weight with  $25 \text{ g/m}^2$ . Two nonwovens (N1 and N4) had lower insignificant weight than conventional fabrics with  $5 \text{ g/m}^2$ .

The thickness at  $2 \text{ g/cm}^2$  ( $T2$ ) and  $100 \text{ g/cm}^2$  ( $T100$ ) of nonwovens is at the high range of the conventional fabrics. However, the surface thickness values of the nonwovens are in the low range of the conventional fabrics. This means that there is similarity between nonwovens and conventional fabrics with respect to  $T2$ ,  $T100$  and  $ST$ .

The extensibility of the measured fabrics was tested and investigated at three loads namely 5, 20 and 100 g/cm. At the lowest load of extensibility (5 g/cm), the nonwovens were inextensible and at the lowest end of  $E5$  range of the conventional. However, the highest end of the conventional fabrics reached around 8%. In the  $E20$  test, the group of nonwovens was still in the lowest range of extensibility of the conventional fabrics, only N1 was still almost inextensible and out of the conventional fabrics range. In  $E100$ , the nonwovens group had lower E values than the conventional fabrics.

The shear rigidity values of the nonwovens and two conventional fabrics (W3 and W5) were almost infinite. This means that they were virtually unable to shear. However the rest of the conventional fabrics were able to shear with  $53 >G \text{ (N/m)} > 15.8$ .

The FAST bending properties i.e.  $BL$ ,  $BR$ ,  $BM$  and  $FR$  were investigated. Two nonwoven fabrics, N1 and N6 had higher  $BL$  than the range determined for the conventional fabrics. The bending rigidity of N6 was higher than the conventional range. In the  $BM$  test, N1 had a higher value than the conventional range. N4, N5, and N6 have similar  $FR$  to conventional fabrics.

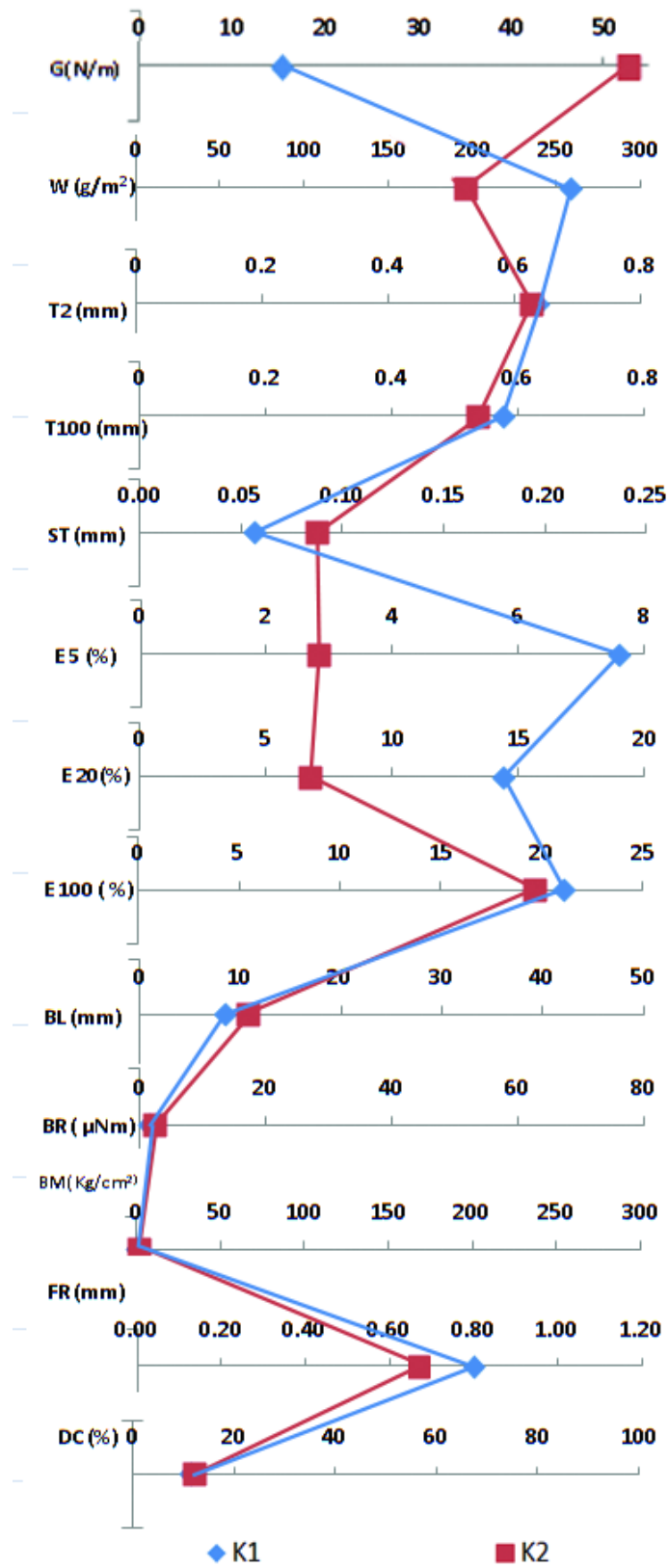
The DC (as a conventional drape parameter) was investigated in order to study the nonwovens tested drapeability and compare it to the conventional fabrics range (limitations). Two fabrics (N2 and N4) from the five nonwovens tested had DC s lie at the high range of DC of conventional fabrics. Three nonwovens (N1, N5, N6) had DC higher than the conventional fabrics'

limitations. This means that N2 and N4 had similar drapeability to some conventional fabrics with low drapeability.

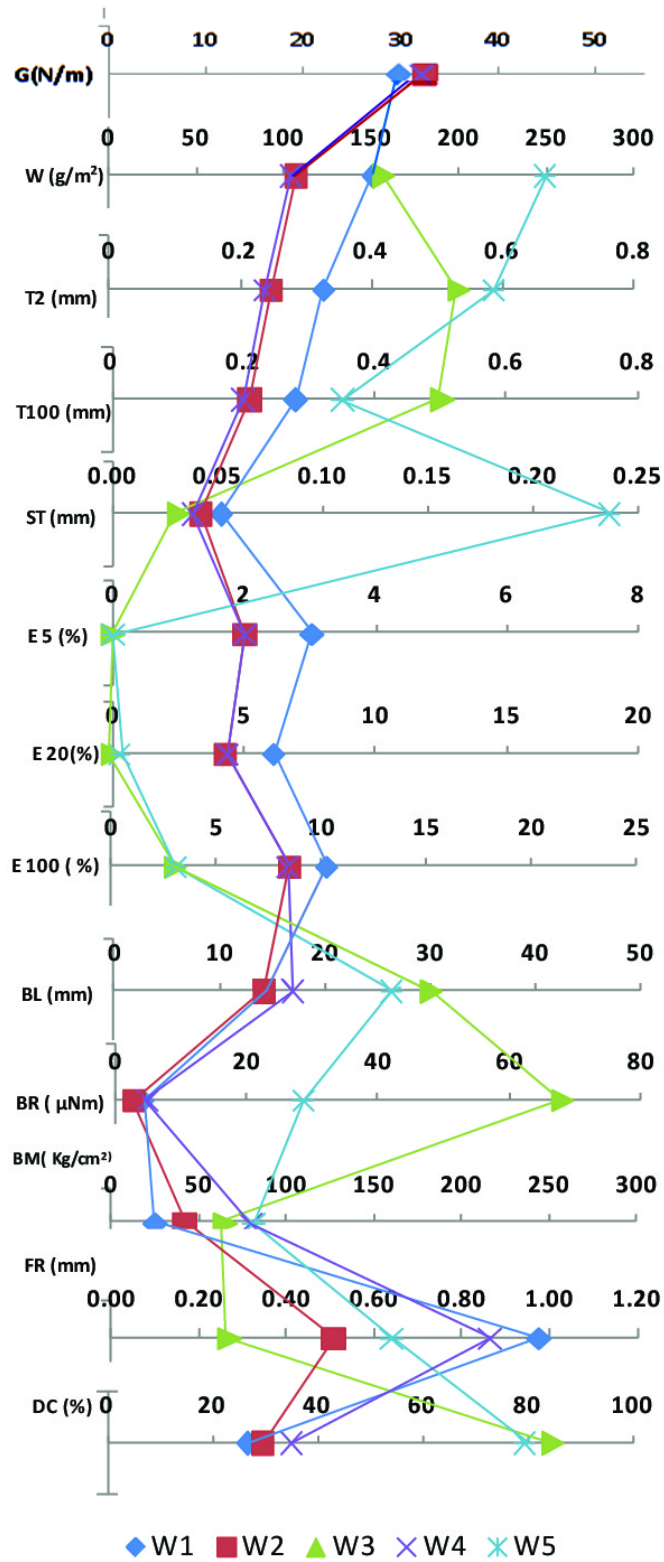
Table 7.3 lists nonwovens' properties which lie inside the conventional fabrics region (presented by an asterisk). The mechanical properties which would make the three nonwovens N1, N6 and N5 out of the traditional fabrics limitation was investigated. N1 had (*W*, *FR*, *BM*, *BL* and *E100*) out of the conventional range, N5 had only the *E100* value out of the conventional range, N6 was differing in (*T2*, *BL*, *BR* and *E100*). Therefore, the increased DC would be as result of the difference in (increased/reduced) *BL*, *BR*, *BM*, *FR* and *E100*.

**Table 7.3** Summary of nonwoven fabrics' properties lying in the conventional fabrics range

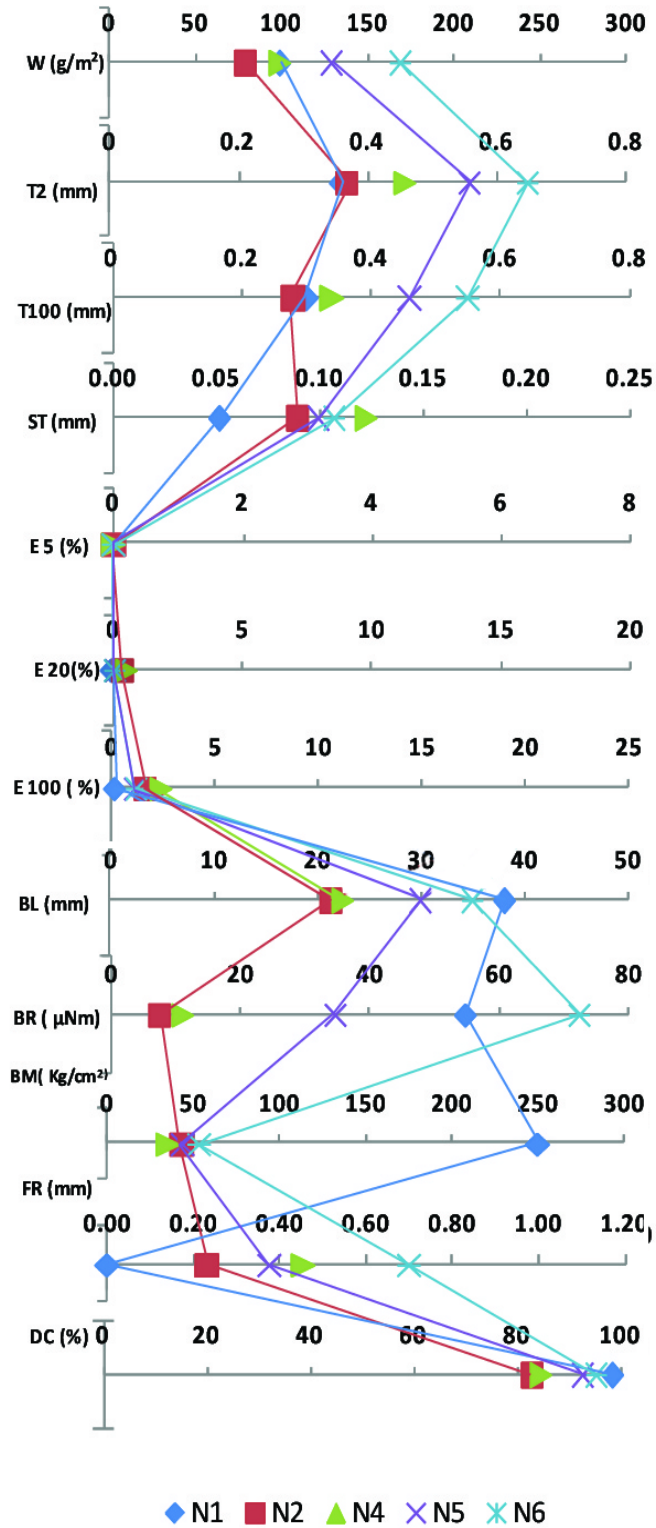
	N1	N2	N4	N5	N6
<b>W</b>			*	*	*
<b>T2</b>	*	*	*	*	
<b>T100</b>	*	*	*	*	*
<b>ST</b>	*	*	*	*	*
<b>E 5</b>	*	*	*	*	*
<b>E 20</b>		*	*	*	*
<b>E 100</b>					
<b>BL</b>		*	*	*	
<b>BR</b>	*	*	*	*	
<b>BM</b>		*	*	*	*
<b>FR</b>			*	*	*
<b>DC30</b>		*	*		



**Figure 7.12** Measured drape coefficient and mechanical properties of knitted fabrics

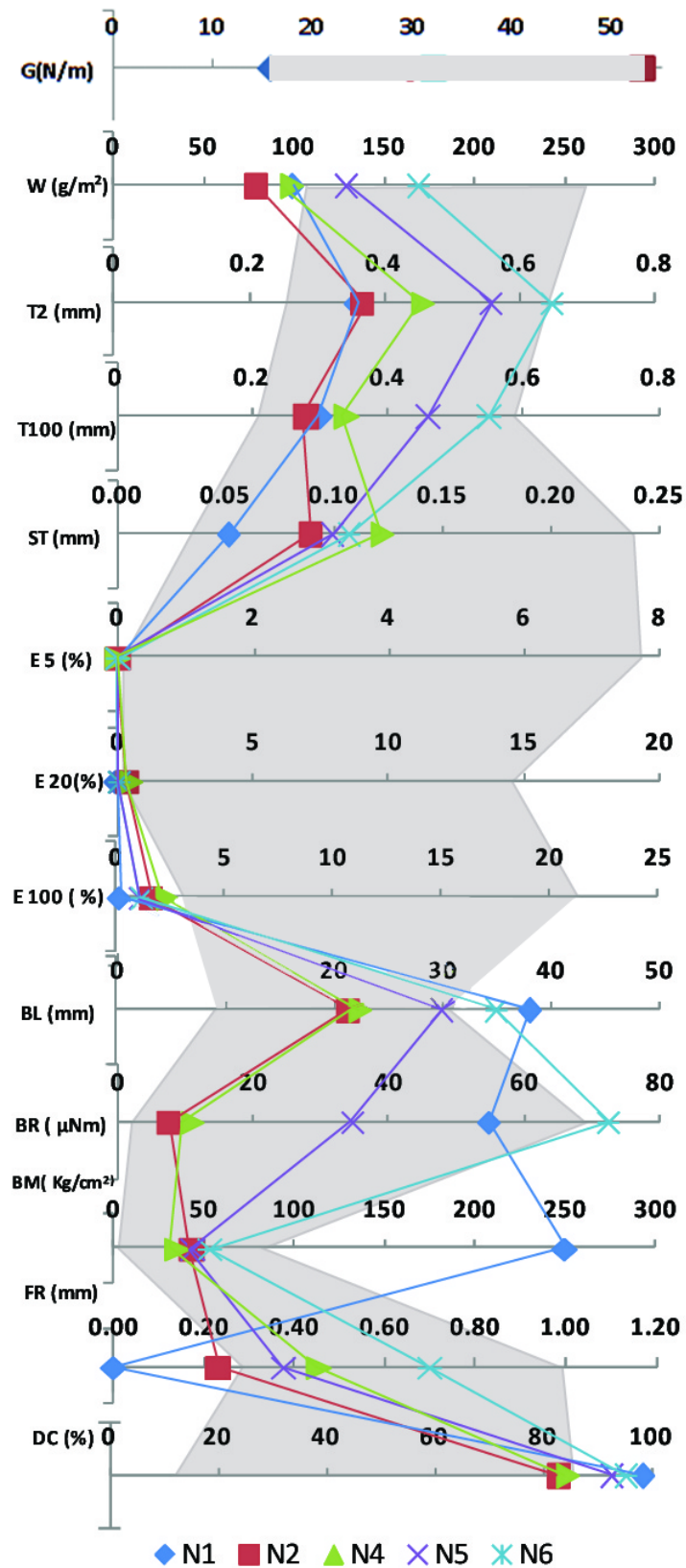


**Figure 7.13** Measured drape coefficient and mechanical properties of woven fabrics



**Figure 7.14** Measured drapability coefficient and mechanical properties of nonwoven fabrics





**Figure 7.15** Correlations between conventional fabrics and nonwovens' measured properties (the shaded areas are for the conventional fabrics)

## 7.4 Summary

The digital and manual methods for measuring fabrics' drapeability used in this study are highly correlated. The number of nodes is correlated with the drape coefficient negatively and strongly. Some nonwoven fabrics produced the highest DC and the lowest and largest node numbers and sizes respectively (if any existed) compared with some conventional fabrics. The nonwoven fabrics vastly differ from some conventional fabrics with regard to fabric drapeability and similar to others. The knitted fabrics had the highest drapeability and higher than the woven fabrics. In the knitted fabrics, the nodes are fewer in the lengthwise direction and larger in the crosswise direction. The nonwovens tended to generate nodes in the machine (lengthwise) direction. All DC36 of the nonwovens are lower than the DC30 and NN36 values are higher than NN30. The nonwoven fabrics were ranked according to their drapeability from the highest: N2 and N4, N5 and N6 and N1 is the lowest (seemingly undrapeable) fabric. The nonwoven fabrics have similar mechanical properties i.e. bending length, extensibility, surface thickness and to some extent in bending modulus, bending rigidity and formability to the conventional fabrics. Therefore, the mechanical properties producing high drape coefficient, these are the extensibility at high load (100g/cm), bending properties and weight.

## **Chapter 8**

### **Assessment of garment drapeability using an image analysis technique**

#### **8.1 Introduction**

Measurement of fabric drape has been carried out using a drape coefficient since 1950 by the development of the Fabric Research Laboratories drapemeter. In 1960, drape shape parameters were proposed by Chu *et al.* for measuring fabric drape, as fabrics could have similar drape coefficients while their drape profiles are different. Since then, different techniques based on image analysis methods have been used to investigate fabric drape and measure drape shape values. In this Chapter, a new combination of drape shape parameters is proposed. Moreover, previous studies concerned with drape shape parameter measurement aimed to predict fabric drapeability for apparel end-use, however no direct comparison was carried out between drape shape parameters of fabrics and garments (fabric form for apparel use) on a mannequin (the real/practical supporting body for a garment). Therefore, it was decided to carry out this comparison using the proposed drape shape parameters. A graphical user interface was developed to calculate these drape values.

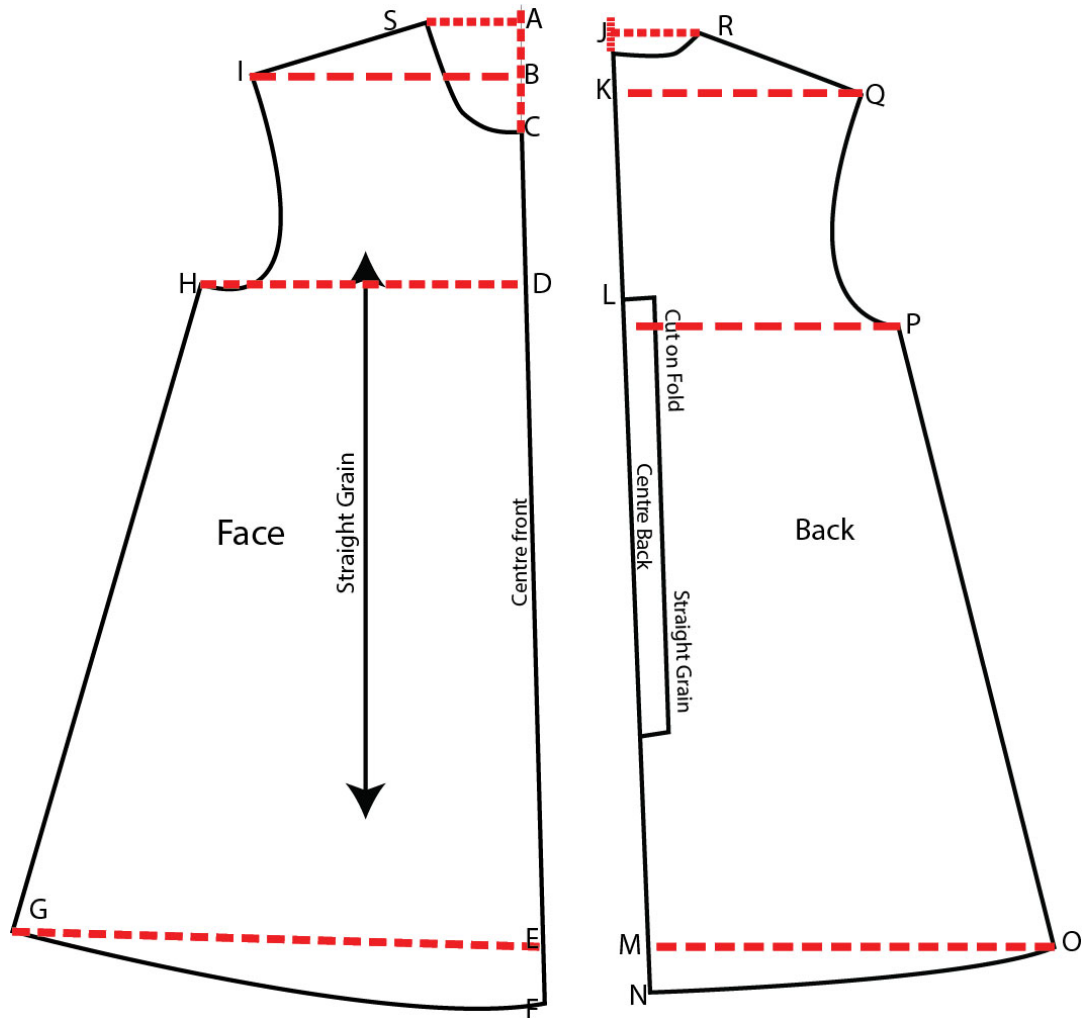
#### **8.2 Experimental**

##### **8.2.1 Samples / Images**

Images analysed in this chapter were taken for the 12 fabrics used in this study (see Chapter 6 for physical and mechanical properties) and garments made from these fabrics.

##### **8.2.1.1 Garment samples (pattern cut and dress making)**

A line shift dress pattern (size 12) was used to cut dresses from the 12 fabrics tested in this study (see Figure 8.1 for the pattern used and its dimensions). All dresses were cut in the fabric lengthwise direction. One centimetre seam allowance was applied in all the dresses. An invisible zip with length 54.5 cm was sewn in the back opening. The centre back seam was stitched from the lowest end of the dress to the zip. In the woven and knitted dresses seam binding was used to finish the neck.



**Face**

AB=4.85 cm      CD=12.6 cm      EF=4.7 cm      HD=27.1 cm      AS=7.8 cm  
 BC=4.58 cm      DE=55.1 cm      EG=44.5 cm      BI=22.6 cm

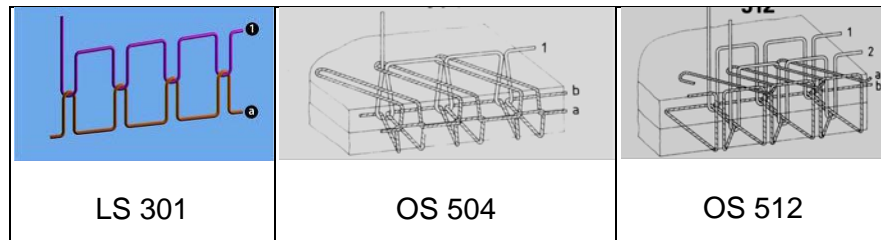
**Back**

JT=1.7 cm      KL=19.5 cm      MN=3.7 cm      LP=22.5 cm      JR=6.9 cm  
 TK=3.5 cm      LM=51.9 cm      MO=34 cm      KQ=20.8 cm

**Figure 8.1** The A line shift dress pattern used to cut the dresses

The 12 dresses made were from three different types of fabric. Suitable stitches and seams were used for each fabric type. The simplest stitches were used in order to obtain the least effect on dress drapeability. Figure 8.2 shows stitch types (British Standards Institution 1991) used in making the 12 dresses. Seam types used in dress making are listed in Table 8.1 (British Standards Institution 1991), each seam type is identified using a numerical designation consisting of 5 digits. The first digit determines the seam class; the second two digits indicate the difference in material configuration, and the last two digits indicate differences in location of needle penetration which is presented by a vertical straight line. Seams used at each area/part on the

dress for the three types of fabrics are shown in Table 8.2, presented by its relative numerical designation followed by seam/s used.



**Figure 8.2** Stitch types used in making the dresses

**Table 8.1** Seam types used in dress making

Numerical designation	Material configuration	Location of needle penetration
1.01.01		
1.01.02		
1.01.06		
3.03.01		
3.14.01		
6.01.01		
6.02.01		

**Table 8.2** Seam and stitch types' locations in Knitted K, Woven W and Nonwoven N fabrics

	Neck	shoulders	Arm holes	Side	Back	Back Zip	lower
<b>K</b>	3.03.01 (504)	1.01.02 (301) (504)	3.03.01 (504)	1.01.01 (504)	1.01.06 (301) (504)	1.01.06 (301) (504)	6.02.01 (512)
<b>W</b>	3.14.01 (301)	1.01.02 (301) (504)	3.14.01 (301)	1.01.02 (301) (504)	1.01.06 (301) (504)	1.01.06 (301) (504)	6.02.01 (504)
<b>N</b>	6.01.01 (301)	1.01.02 (301) (504)	6.01.01 (301)	1.01.02 (301) (504)	1.01.06 (301) (504)	1.01.06 (301) (504)	6.01.01 (301)

### 8.2.1.2 Garment images (Picture capture and preparation)

A mannequin was used for suspending the dresses with the following dimensions in centimetres: Bust =87, Waist= 64, Hips= 92, Back neck waist= 40.5 (see Figure 8.3). Photos were taken for each dress on this mannequin from underneath (Figure 8.4 shows an example of one of the original pictures captured).

Each picture captured was converted into a black and white image using Photoshop software. Steps performed in Chapter 8 were applied on the dress images to obtain black and white images (see Figure 8.5).

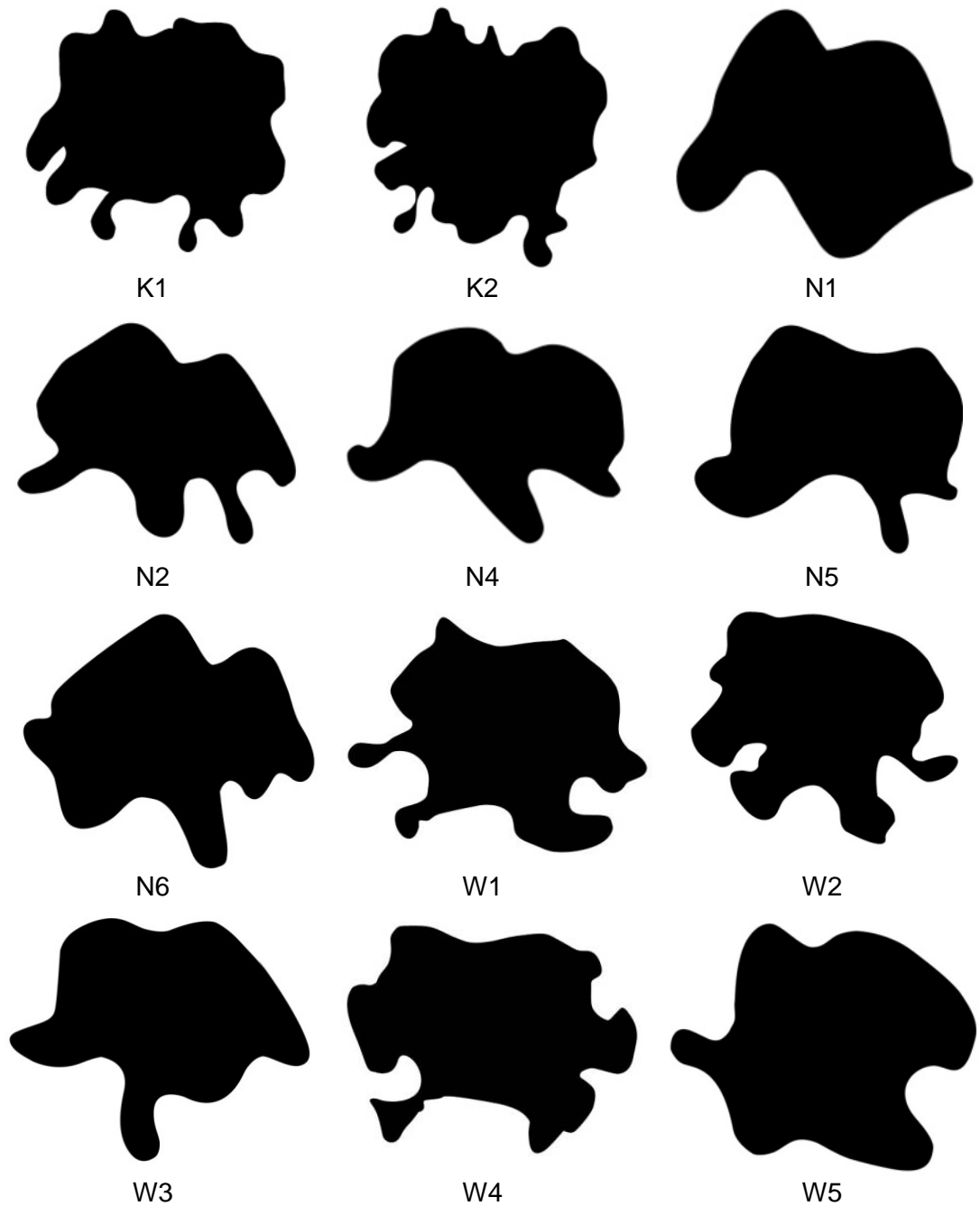
It is very important to adjust each image to be 1:10 scale of the original image with 100 pixel/cm. This specification is necessary to obtain the correct results later when an image is processed.



**Figure 8.3** Different views for the mannequin employed



**Figure 8.4** Original image captured for a dress on the suspended mannequin

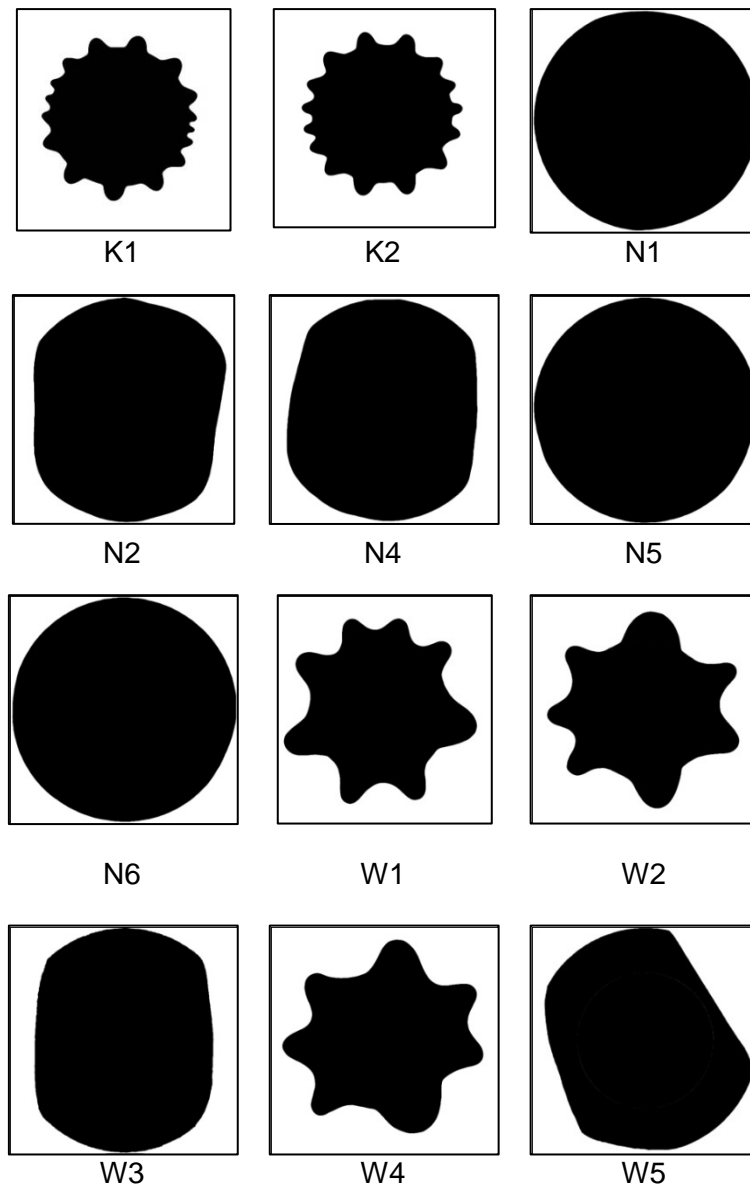


**Figure 8.5** Dresses' images used for image analysis

### 8.2.1.3 Fabric samples/images

Images used in Chapter 7 (Measurement of drape coefficient) which were taken for circular fabric samples with 30cm diameter on a Cusick drapemeter were analysed. However, these produced filled solid shapes as shown in Figure 8.6.





**Figure 8.6** Fabricimages used for image analysis

### 8.2.2 Image analysis procedure

Each processed image passed through the following procedures in order to obtain the values calculated in this study:

A monochrome (black and white/binary) image was converted into a polar plot  $(\theta, r)$ , as the discrete points making up the image's contour were converted into/realised as polar coordinates, where the distance from the

pole (analogous to the origin of a Cartesian system) is the radial coordinate or radius  $r$ , and the angle is the angular coordinate, polar angle  $\theta$ .

The polar plot was converted into Cartesian plot  $(x, y)$ , where  $x$  was the angle of each coordinates and  $y$  was the radius. This plot was called the shape signature as it presented the original distinctive wave of each image.

The ideal (reconstructed) wave shape was recomposed from the determined average wave values measured; namely wave length, amplitude and height.

A Fast Fourier transform was performed to convert the original Cartesian plot into a frequency domain.

In this study, twenty one shape parameters were selected as drape values. These were subdivided into four groups: the first group was the “Basic drape shape characteristics”; the second group was the “wave measurements”, the third was “wave analysis” and the last one was “Fourier”.

In the “Basic drape shape characteristics” group, the general shape properties were measured including:

- Perimeter ( $P$ ): This is the length of the processed shape outline measured in centimetres (Costa and Jr 2000; Haidekker 2011).
- Area ( $A$ ): This is the amount of space inside the boundary of shape measured in centimetres square (Costa and Jr 2000).
- Circularity (CIRC): This is a measure of shape complexity and sharpness (see Equation 8.1) (Robson and Long 2000).

$$\text{CIRC} = 4\pi A / P^2 \quad 8.1$$

where:  $A$  is the area and  $P$  is the Perimeter. CIRC can take a value in the range 0 to 1, where  $\text{CIRC} = 1$  for a perfect circle and CIRC tends towards 0 for more complex profiles. This parameter showed strong correlation with the conventional drape parameter (Drape coefficient) (Robson and Long 2000). It was decided to use it in this study as an alternative for drape coefficient as the latter is not applicable to garment images.

It is noteworthy that another complexity shape parameter Area/ Perimeter ( $A/P$ ) (Costa and Jr 2000; Haidekker 2011) was found to have strong correlation with circularity ( $r_{\text{Dress images}}=0.96$ ,  $p < 0.00001$  and  $r_{\text{Fabric images}}=0.995$ ,  $p < 0.00001$ ). The  $A/P$  parameter showed negative/reverse relation with drapeability as this ratio increased with low drapeable samples. However the Circularity was used for its advantage in being compared with perfect circle.

- Symmetry: This is the reflection symmetry which measures the degree of two halves of a shape identical over vertical axis (Y) for Left/Right symmetry and over horizontal (X) axis for Front/Back symmetry. Symmetry ranges between 0 (completely asymmetrical two halves) and 1 (identical symmetrical parts) (Costa and Jr 2000). This was calculated using 2-D Correlation coefficient (Corr2) function in MATLAB software which computes the correlation coefficient between two matrices of the same size.
- Number of peaks: This is the number of peaks/ nodes making up the original wave of the shape signature. The threshold of Peak-Trough distance/length stated in Shyr et al's study which was found reliable to determine the number of drape wave peaks 0.3 cm was applied to detect the peak number (Shyr, Wang and Lin 2009). In MATLAB software, the function [pks, locs] = FINDPEAKS(X,'THRESHOLD',TH) was used to find the peaks that are at least greater than their neighbours by the threshold TH, where X is the data vector.

In the “Wave measurements” group: The average, maximum, minimum and variation of single waves constituting the wave shape were computed. This was based on two successive peaks making up a single wave in the entire wave representing the original shape. According to this the calculations were conducted as follows:

- Wavelength (WL) (degrees): This is a measure of the distance between repetitions of a shape feature. In this study the distance between two successive peaks was used, expressed in degrees of a circle (from 0° to 360°). It was calculated using Equation 8.2: (see Figure 8.7) (Jevšnik and Žunič-Lojen 2007).

$$WL_i = Peak_i - Peak_{i+1} \quad 8.2$$

- Wave height (WH) (cm): One of the drape shape parameters indicating the wave distance/displacement/elevation from the centre of the supporting body. This was measured using Equation 8.3.

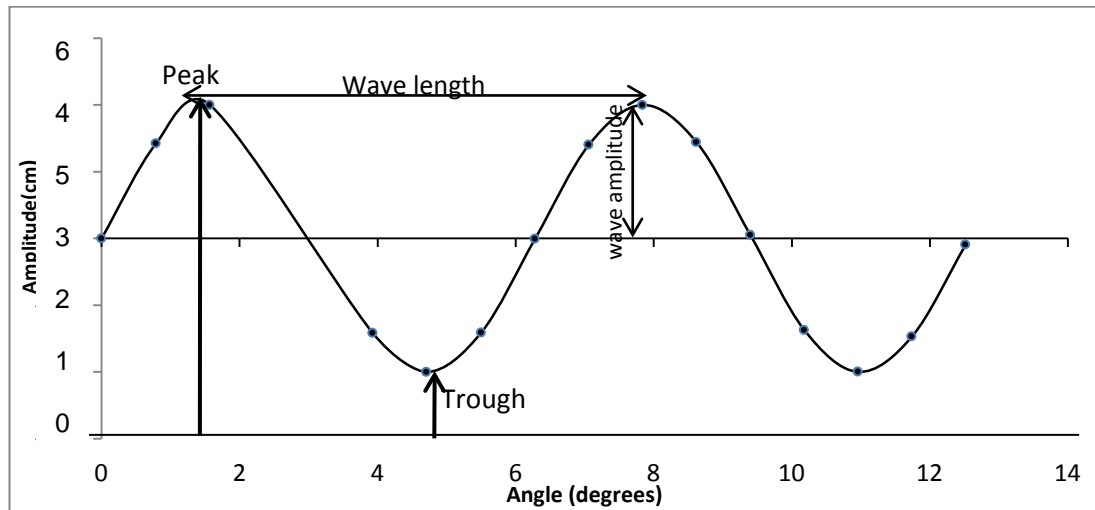
$$WH_i = \frac{Peak_i + trough_i}{2} \quad 8.3$$

where:  $Peak_i$  and  $trough_i$  are two successive peaks and troughs. Each peak and trough was measured from the X axis (see Figure 8.7) (Pandurangan et al. 2008).

- Wave amplitude ( $WA$ ) (cm): One of the drape shape parameters indicating the size and magnitude of change in the oscillating fabric edge. Peak-to-trough amplitude is the change between peak (highest amplitude value) and trough (lowest amplitude value) (see Figure 8.7). Each peak and trough was measured in terms of its distance from the x axis (British Standards Institution 2008). This is a measure of wave depth with respect to the relation between peak and trough (see Equation 8.4).

$$WA_i = \frac{Peak_i - trough_i}{2} \quad 8.4$$

The reason for selecting this combination of shape parameters (wave amplitude, length and height) was that these are the essential parameters to represent/ draw any wave.



**Figure 8.7** Measurement of wave characteristics/dimensions (length, amplitude and height)

In the “wave analysis” group, the following drape shape parameters were calculated:

- $AM/WH$ : This is the ratio of wave amplitude to wave height. (Sharma *et al.* 2005), calculated using Equation 8.5.

$$AM/WH = \frac{(Hmax - Hmin) / 2}{WH A} \quad 8.5$$

where:  $Hmax$  and  $Hmin$  are maximum and minimum radii respectively,  $WH A$  is the wave height average.

- $WH/WL$ : This is the ratio of wave height to wavelength. This is a measure of drape fold severity (Robson and Long 2000). It was calculated using Equation 8.6.

$$WH/WL = \text{Mean}(Hi/Li)$$

8.6

where:  $Hi$  and  $Li$  were each single wave height and length respectively.

In the “Fourier” measurements group, three parameters called fitness factors which investigate the reliability of using Fourier transformation to represent drape were calculated:

- Fourier (F)(cm): This is the area under the frequency (Fourier) plot for the measured shape. The Fast Fourier transform (fft) function in MATLAB software was used to perform this transformation.
- Fourier/Original (F/O)(%): This is the ratio between areas under frequency and original curves.
- Dominant/Original(D/O) (%): This is the ratio between areas under reconstructed and original curves.

### 8.2.3 Apparatus/Tools

A graphical user interface (GUI) called “Drape” was developed in MATLAB software to enable calculating the required drape parameters (see Figure 8.8). Before constructing the “Drape” GUI, the following questions were answered:

- Who the “Drape” GUI users will be: They will be garment makers and designers, simulation scientists, CAD/CAM software developers and textile engineers interested in drape measurement.
- What will the “Drape” GUI be used for (user requirements including input, outputs and displays): It will be used for processing input images to measure drape shape values and display charts for some of these measurements.
- How users will interact with the GUI: The user will upload the image to be analysed and would export the results to Excel software.
- What components the GUI requires to function: In Drape GUI a user selects an image using “New” from “File” menu. The selection of any image with certain specifications (ratio 1:10 of the original size and resolution 100 pixel/cm) make the GUI read and analyse the image i.e. calculate the drape shape parameters. There is another menu called “Edit” which includes “To Excel” by which the operator could export the measured values to Excel software.

In MATLAB software a guide was used to create “Drape” GUI. This is a graphical display in one window containing controls (components) that

enable a user to perform two interactive tasks. These were uploading the image to be analysed and exporting the analysis results to Excel software.

Figure 8.8 shows the Graphical user interface displaying one of the processed image's results, the value of each parameter calculated for the relative image is displayed next to it. The question mark push buttons were used to display the definition of the corresponding drape parameter in the "Definition" box.

Three axes of components exist in Drape GUI: the one at the top right displays the original analysed image, the second axis below the original image presents the Fourier transform plot, and the third axis component at the bottom of the Drape GUI displays the Cartesian plot transformation from the Polar plot of the original drape profile, the peaks and the reconstructed wave from the average wave values in terms of wavelength, wave amplitude and wave height average.

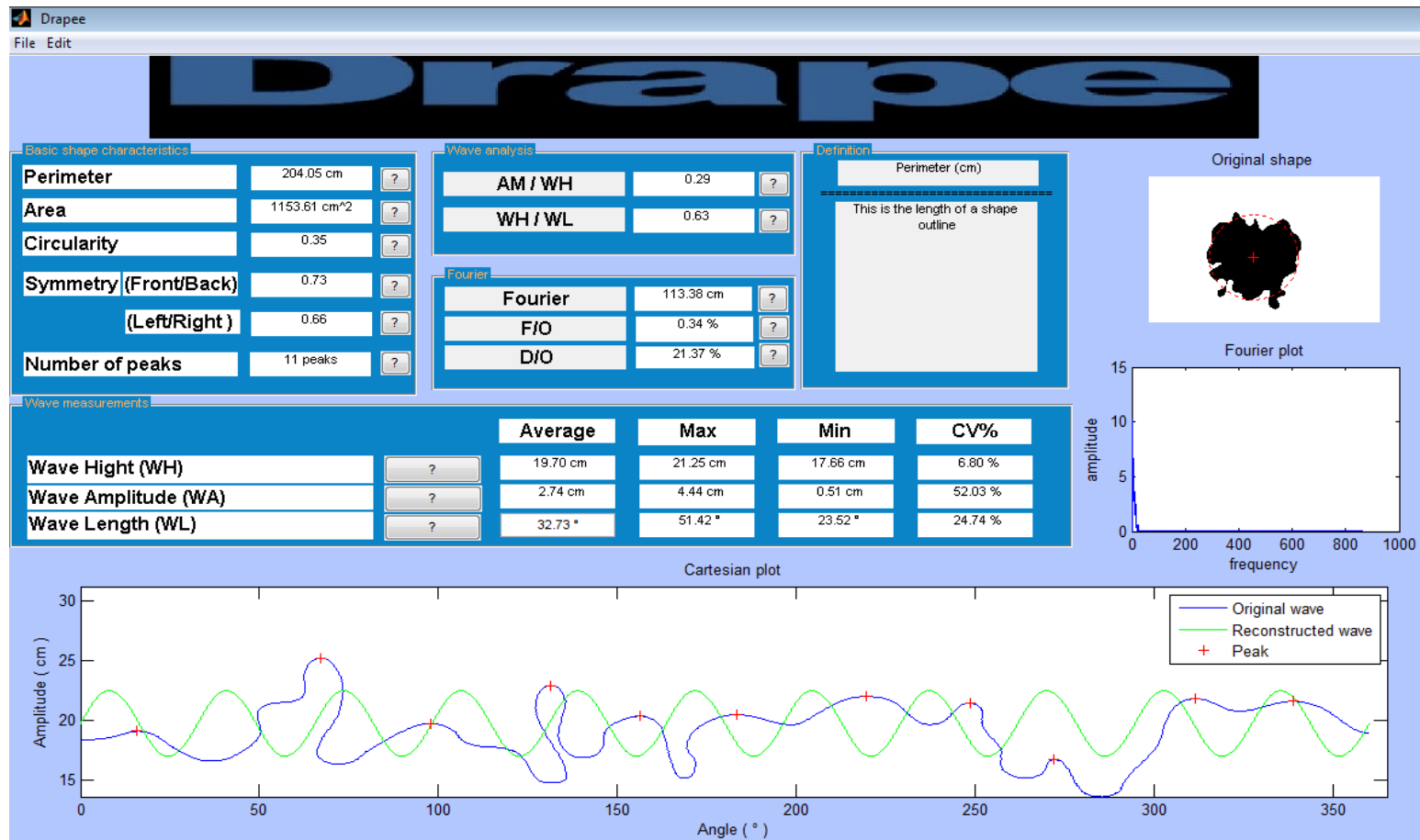


Figure 8.8 “Drapee” Graphical user interface (example of image processed)

### 8.3 Results and discussion

#### 8.3.1 Correlation between fabric and garment drape values

In this study, two groups of samples (fabrics and dresses) were analysed. Each group included 12 samples. Five photos were taken for each sample. Fabrics were captured on a Cusick drapemeter and the dresses were photographed from underneath the mannequin used. Each image was processed using a “Drape GUI” to obtain the drape values proposed. The results of each test (image) were exported to Excel software to calculate the average of each parameter from the five replicas captured.

The correlations between fabric and garment drape values resulting from the image analyses were investigated. Table 8.3 lists the correlation coefficients and coefficients of determination calculated for the 12 fabrics and their correspondent dresses and ranked from the strongest to the weakest.

**Table 8.3** Correlation coefficients and coefficients of determination between parameters measured for fabrics and dresses tested

	r	R <sup>2</sup>
Circularity	<u>0.91</u>	0.84
Peaks	<u>0.83</u>	0.69
Area	<u>0.64</u>	0.41
Perimeter	<u>-0.61</u>	0.37
<i>WH/WL</i>	0.55	0.30
<i>WH A</i>	-0.44	0.20
<i>WA Max</i>	-0.36	0.13
Fourier	0.36	0.13
<i>WH Min</i>	-0.34	0.12
<i>WA CV</i>	-0.34	0.12
<i>WH Max</i>	-0.34	0.12
F/O	0.34	0.12
<i>WA Min</i>	0.32	0.10
<i>WL A</i>	0.29	0.09
Sym (R-L)	-0.27	0.07
<i>AM/WH</i>	-0.25	0.06
<i>WA A</i>	0.23	0.05
D/O	-0.19	0.04
Sym (F-B)	-0.14	0.02
<i>WL Min</i>	0.12	0.01
<i>WH CV</i>	0.11	0.01
<i>WL Max</i>	-0.11	0.01
<i>WL CV</i>	-0.02	0.00



It is evident from Table 8.3 that just 4 drape values (from the fabric and dress images) namely Circularity, Peaks number, Area and Perimeter from the 23 drape values measured had significant correlations. The highest correlation is for the Circularity with  $R^2 = 0.84$  followed by moderate  $R^2 = 0.69$  for the number of peaks. However the Area and the Perimeter have weak correlations with 0.41 and 0.37 coefficients of determination respectively. Circularity and number of peaks were always considered as conventional parameters for fabric drapeability. It is believed that these two parameters characterise only the overall degree of drapeability not highly/significantly correlated with drape profile parameters. This would explain the reason for insignificant and weak correlations between the rest of the drape values measured for fabrics and dresses which are responsible for establishing drape shape. The drape shape parameters are highly dependant on the fabric form and supporting body. Therefore, it would not be reliable to predict garment drape shape using the drape shape values measured for fabrics.

### 8.3.2 Correlation between drape coefficient and drape values measured for fabrics on drapemeter

The correlations between the drape values measured using “Drape” GUI and drape coefficient values measured previously in this study were investigated, see Table 8.4 for the significant correlations found.

**Table 8.4** Significant correlations between Drape coefficient and Drape values

	r	R <sup>2</sup>
Circularity	<u>0.99</u>	0.97
Peaks number	<u>-0.96</u>	0.91
WH/WL	<u>-0.83</u>	0.69
F/O	<u>-0.65</u>	0.42
D/O	<u>-0.64</u>	0.41
Perimeter	<u>0.62</u>	0.38
Sym (R-L)	<u>0.57</u>	0.33

DC was dependant on area ratio which means that Area parameter was completely consistent with DC. Another two very strong correlations were found between the DC and each of Circularity ( $R^2 = 0.97$ ) and Number of Peaks ( $R^2 = 0.91$ ). Good reverse correlation was found between DC and *WH/WL* (measure of node severity), as node severity decreases with increased DC (decreased drapeability). *F/O*, *D/O* and Perimeter were found with significant weak correlations with DC  $R^2 = 0.42$ , 0.41 and 0.38 respectively. Symmetry (R/L) had the least significant correlation  $R^2 = 0.33$ .

This means that Area>Circularity>Peaks number>*WH/WL* were alternative predictors for drape coefficient, however the area is the best alternative.

#### **8.4 Summary**

It was found that drape shape parameters of a garment could not be predicted using corresponding fabric drape shape parameters. This is because of the poor correlations between most of the drape parameters measured for fabrics and dresses tested. This means that textile engineers and scientists working on drape measurement and simulation should measure drape shape properties for a garment on a mannequin rather than flat fabric supported on circular disc.

Strong and good correlations were found between DC, Circularity and Peak number. Therefore any of these parameters could be used as alternative parameters for DC.

## **Chapter 9**

### **Subjective assessment of fabric and garment drape**

#### **9.1 Introduction**

Fabric and garment drape is a visual property which is being evaluated subjectively in the fashion and apparel industries by professionals employing visual and tactile senses. Therefore, drapability assessment is practically a subjective process.

Textile researchers have worked on developing objective measurement methods to cope with limitations in subjective assessment of drape including inconsistency between judges, inaccuracy and high cost. The first drapemeter developed by Fabric Research Laboratories was based on simulating the process of displaying fabric yards in windows shops for clients (Chu 1950). Although, panels of assessors were employed to relate instrumentally measured drape values to subjective evaluations of drape. Strong correlations between subjective and objective measurements were used to validate a developed drapemeter or method for measuring drape. Subjective drape assessment was carried out in terms of drape level and/or preference.

This study was concerned with proposing an alternative system for measuring garment drape objectively (based on an image analysis technique) and investigating its correlation with actual fabric drape behaviour. Therefore, it was found that investigating subjectively this relationship employing the objectively analysed images was important. Another drape level assessment of real materials (fabrics and garments) was conducted in order to simulate the process of professional fashion designers and makers' assessment of drape which is based on viewing and touching the fabric being assessed.

Drape preference, as well, was investigated. As one of the main objectives of this study is considering the drapability of nonwoven fabrics, it was decided to examine the desirability of purchasing nonwoven garments with given drape levels amongst the group of garments tested including conventional and nonwoven fabrics. This was another reason for using real samples as studying drape preference has to be carried out using real samples.

## **9.2 Experimental**

### **9.2.1 Assessment/Ranking method**

In previous studies concerned with subjective assessment of fabric and garment drape, evaluations were carried out to rank tested fabrics and/or garments using either paired comparison (Cusick 1962; Agarwal, Koehl and Perwuelz 2011) or rating methods at 7 (Collier 1991, Orzada *et al.* 1997) or 10 point scales (Mahar *et al.* 1990, Uçar *et al.* 2004) in order of most and/or preferred drape.

Slater found that in textile subjective experiments the rating method often lacks accuracy, since there is the probability of inconsistent evaluation among observers due to using different scaling techniques. He also suggested using paired comparison or ordinal ranking methods for subjective assessments of textile properties as more reliable methods (Slater 1997). In this study, it was found that using the paired comparison method produced 66 pairs in each assessment from 5 assessments using only one judge. This was found impractical.

Therefore, in this study, all assessments were carried out using an ordinal ranking method to compel each judge to prioritise items being assessed with respect to the property/attribute evaluated. Each judge was asked to order items being assessed according to the attribute tested.

### **9.2.2 Samples**

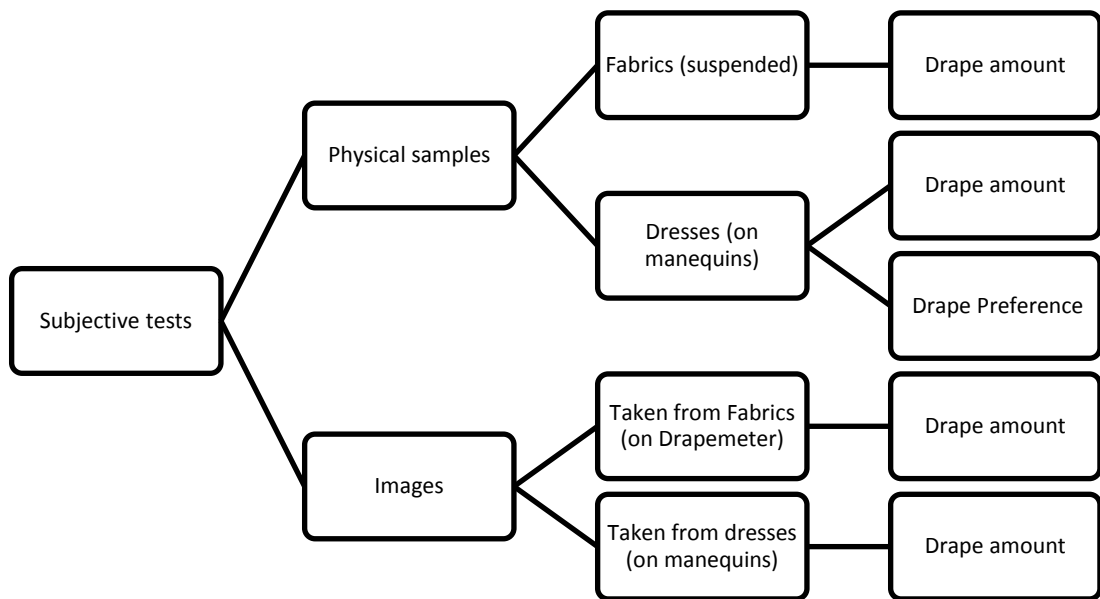
Twelve fabrics tested in Chapter 6 (see Sections 6.1.3 and 6.9 for physical and mechanical properties respectively) were evaluated in this chapter in fabric and garment forms.

In the fabric tests, circular specimens of 30 cm diameter were used on the drapemeter tests. In the garment tests, the dresses used in Chapter 8 were employed again.

### **9.2.3 Presentation of samples**

In previous research studies, subjective assessments were carried out using real samples displayed on a supporting body (Cusick 1962) with either handling/touching (Agarwal, Koehl and Perwuelz 2011) or viewing images of the fabrics being assessed (Uçar *et al.* 2004).

In this study, subjective assessment of fabric and garment drape was carried out using both fabrics and garments and their images (see Figure 9.1 is a summary of the subjective tests conducted).



**Figure 9.1** Summary of subjective tests conducted

### 9.2.3.1 Fabrics and garments (real samples)

In this test, a convenience sample of 20 third year students of the Fashion design programme graduating in 2012 were the assessors. Prior to the test, “Drape” was defined to each judge to clarify the test and orient the judge. It was defined as the fabric’s ability to deform and orient itself into graceful folds or pleats when it is suspended under its own weight (British standards Institution 1973; Chu, Cummings and Teixeira 1950).

In the fabric drapeability test, the 12 fabrics employed in Chapter 7 were used. They were hung from one tip to allow them to make folds. Assessors were asked to order them from the most drape with highest number of folds/nodes to the least drape and node number. They were allowed to handle and touch the fabrics.

In the garment tests, 12 garments used in Chapter 8 and constructed from the fabrics used in the previous test were hung on 12 mannequins of the same size (12) in a line (see Figure 9.2). The mannequins were arranged randomly in a row in front of the judge. First, each judge was asked to rank the dresses for drapeability (highly drapeable garments have the ability to make folds/ nodes when it is hung) and then to order them according to drape preferred.

Students were allowed to examine the dresses closely and touch them if necessary. Therefore, the evaluation process was dependant on visual and

tactile senses which are usually used by apparel designers, makers and consumers in a drape assessment process.

### **9.2.3.2 Images assessment**

In this test, 2 groups of black and white images for fabrics and garments were assessed. Fabric images were taken for the draped fabric on the Cusick drapemeter and used in objective assessments in Chapters 7 and 8. Dress images were the ones taken for the dresses from underneath the mannequin when they were suspended (used in Chapter 8).

20 individuals were asked to rank the images of each group for drape ability. They were asked to order the images from most complex and deformed shape with high number of peaks to the lowest number of peaks.

### **9.2.4 Data analysis**

An ordinal ranking method was applied in ranking the samples presented to the observers with respect to the property tested. The collected ranks were analysed using the following procedures:

1. Kendall's  $W$  (also known as Kendall's coefficient of concordance), a non-parametric statistic was computed. This is a normalisation of the statistic of the Friedman test, and can be used for assessing agreement among judges. There is a close relationship between Friedman's two-way analysis of variance without replication by ranks and Kendall's coefficient of concordance in terms of their hypotheses (which is on the same data collected) and using the same  $\chi^2$  statistic for testing. They differ only in the formulation of their null hypothesis. In Friedman's test, the null hypothesis is that there is no real difference among the  $n$  objects.  $H_0$  is accepted if they have random ranks from the various judges, so that their sums of ranks should be approximately equal. However, Kendall's test is concerned with  $r$  judges. If the null hypothesis of Friedman's test is true, this means that the judges have produced rankings that are independent of one another. This is the null hypothesis of Kendall's test (Friedman 1937; Kendall and Smith 1939; Legendre 2005)



**Figure 9.2** Dresses tested in the subjective assessment (real garments)

Friedman's  $H_0$  is that the  $n$  objects are drawn from the same statistical population. However, Kendall's  $H_0$  is that the  $r$  judges produced independent rankings of the objects. Kendall's  $W$  ranges from 0 (no agreement) to 1 (complete agreement).

To compute Kendall's  $W$  statistic (see Equation 9.1), a matrix was set for each set of test results as each row represented an observer (for  $n_o$  observers), and each column represented a stimulus/fabric (for  $n_t$  fabrics) (Leaf 1987).

$$\text{Kendall's } W = \frac{12S}{r^2n(n-1)(n+1)} \quad 9.1$$

where:  $S = \sum(R_j - \bar{R})^2$ ,  $R_j$  = rank sum of each object/fabric,  $\bar{R} = \frac{r(n+1)}{2}$ ,  $r$  = the number of observers,  $n$  = the number of fabrics.

Because in this study  $n > 7$ ,  $W$  was tested for statistical significance using Friedman's  $\chi^2$  statistic. Friedman's  $\chi^2$  statistic was obtained from  $W$  using the formula:  $\chi^2 = r(n-1)W$ . This quantity ( $\chi^2$ ) follows a chi-square distribution with  $(n-1)$  degrees of freedom. In this study, the  $p$  value was calculated using function CHIDIST ( $T$ ,  $DF$ ) in Excel software. This function returns the one tailed probability (the right hand tail area) of the Chi-squared distribution. Therefore,  $p$  value  $< \alpha$  (significance level) shows the significance of  $W$ . If the  $p$  value is less than the significance level, the null hypothesis is of complete independence of the rankings which is therefore rejected, and it is concluded that there is a real measure of agreement among judges. A final overall ranking of the fabrics according to the average ranks could therefore be justified.

To summarise, each test had the following results at the end:

- Kendall's  $W$
- Friedman's  $\chi^2$  statistic (ChiSq).
- $df$
- $p$  value
- The average rank values (when  $H_0$  was rejected).

2. If  $H_0$  was rejected ( $p$ -value  $< \alpha$  (significance level)), the fabrics average ranks could be used. But how these fabrics were different, as it is important to find out where the differences among the populations means are. A multiple comparison test (MCT) was considered to answer this question and as a Post-hoc test in order to decide which groups are significantly different from each other. It measures the difference between all possible pairs of fabric means. It was found that different MCTs available



differ according to the power of the calculations. Bonferroni's method for MCT was selected because it could be used to control the family (experiment-wise) type 1 error rate in any multiple testing situation to  $\alpha_{\text{family}}$  (see Equation 9.2). So, the individual tests were performed using a reduced value of  $\alpha$  called Bonferroni-corrected (Mathews 2010; Dowdy, Wearden and Chilko 2011).

$$\alpha = \frac{\alpha_{\text{family}}}{K} \quad 9.2$$

where:  $K$  (number of all possible comparison tests) =  $\frac{n(n-1)}{2}$ ,  
 $n$  is the number of objects (=12 in this study).

Therefore  $\alpha$  was calculated as follows  $\alpha = \frac{0.05}{12(12-1)/2} = 0.0008$ . This test performed more than one hypothesis test simultaneously. The null hypothesis was that each pair was equal. This was rejected if the absolute difference between any pair is higher than the test threshold or significant range.

This significant range is called Least Significant Difference (LSD) and calculated using Equation 9.3 (some results were taken from the ANOVA table):

$$\text{LSD} = t_{\text{crit}} S_{\text{pooled}} \sqrt{\frac{2}{K}} \quad 9.3$$

where:  $t_{\text{crit}}(\alpha_{\text{Bonferroni}}, df_{\text{within}})$ ,  $S_{\text{pooled}} = \sqrt{\text{RMS}}$ .

If the difference between two means of rank was equal or greater than this critical value (LSD), it is concluded that there was sufficient evidence that means of populations were different. To perform this test, fabrics were arranged ascendingly according to average rank results and the differences between them were set in a matrix. The end product of the multiple comparisons matrix was presented as a collection of groups, where a group was defined to be a set of populations with sample means not significantly different from each other. This information was summarised by ordering the samples from least to highest rank average, and then connecting the fabrics in the same group.

### 9.3 Results and discussion

Drape ability of fabrics and garments and their images was assessed subjectively using panels of judges. Drape preference of garments was assessed as well.

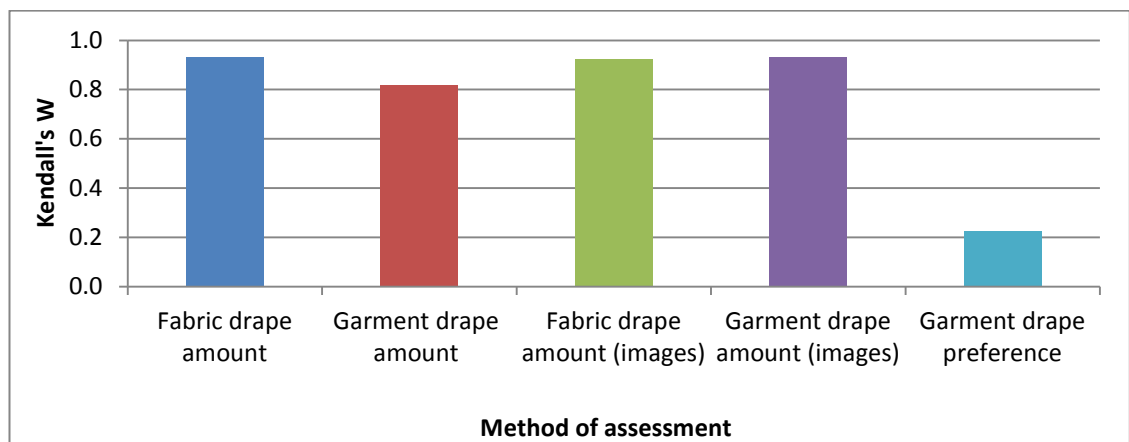
### 9.3.1 Agreement between judges (producing rank average)

Kendall's coefficient of concordance (W) was calculated for each assessment to investigate the agreement between judges (see Table 9.1 and Figure 9.3 for test results). It is evident that Kendall's W coefficients for fabric drape ability, garment drape ability, fabric drape ability (images), garment drape ability (images), and garment drape preference tests were significant  $p$  value  $\leq 0.01$ . This means that correlations found were not obtained by chance and if these tests will be repeated, similar results will be obtained. It is obvious that the assessment of fabric drape ability using any method and material (fabrics or their images, garments or their images) produced high and consistent agreement between judges. Kendall's W coefficients (of drape ability)  $W \geq 0.82$  were much higher than  $W = 0.22$  for garment drape preference assessment. This means that there was a significant low agreement between judges with regard to garment drape preference.

Methods of evaluating drape ability used were ranked from the highest to the least agreement as follows: Garment (images) > Fabric > Fabric (images) > Garment.

**Table 9.1** Kendall's W test statistic for methods of drape assessment

	Fabric drape ability	Garment drape ability	Fabric drape ability (images)	Garment drape ability (images)	Garment drape preference
Kendall W	0.93	0.82	0.92	0.93	0.22
ChiSq	204.59	179.48	203.02	204.94	49.16
df	11	11	11	11	11
p=<	0.01	0.01	0.01	0.01	0.01



**Figure 9.3** Kendall's coefficients of concordance for methods of drape assessment

### 9.3.2 Correlation between methods

Correlations between tests' results were studied using the average rank values to investigate how these assessment methods of drape were related to each other (see Table 9.2).

**Table 9.2** Correlation coefficient between drape assessment tests

	Fabric drape ability	Garment drape ability	Fabric drape ability (images)	Garment drape ability (images)	Garment drape preference
Fabric drape ability	1				
Garment drape ability	0.98	1			
Fabric drape ability (images)	0.92	0.94	1		
Garment drape ability (images)	0.87	0.92	0.83	1	
Garment drape preference	0.78	0.80	0.81	0.83	1

It was found that all correlations were high and significant  $r \geq 0.83$ ,  $p < 0.01$ . The highest correlation was between fabric (real) and garment (real) drape ability  $r = 0.98$ ,  $p < 0.01$  ( $R^2 = 0.96$ ).

The correlation between fabric and garment drape ability (images) was found to be  $r = 0.83$ ,  $p < 0.01$  ( $R^2 = 0.69$ ).

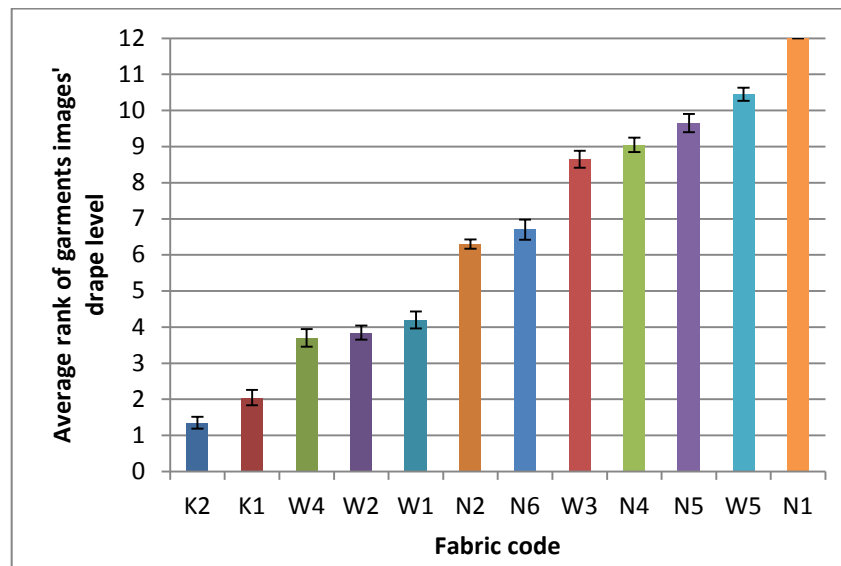
Correlations between drape ability of fabrics (real) and their images, and between garments and their images were found to be  $r = 0.92$ ,  $p < 0.01$  ( $R^2 = 0.84$ ).

The average ranks of garment drape preference was correlated positively with fabric drape ability assessed using either of the four methods,  $r \geq 0.78$ ,  $p < 0.01$  ( $R^2 \geq 0.6$ ). This means that highly drapeable garments were preferred by judges over low drapeable fabrics. This preference was consistent with the fashion trend of high drapeable fabrics/garments.

The strong significant correlation coefficients between different tests (methods) of evaluating drape ability illustrates that equivalent results could be obtained when evaluating drape ability subjectively using either form of fabric or garment using real materials or their images. Therefore, drape ability assessment could be conducted using any of the applied approaches.

### 9.3.3 Drape ability ranking

The ranking of drape ability using fabric, their images, garments and their images were highly correlated and significant. However, it was decided to choose the method with highest degree of agreement between judges to study the drape ability ranking. The drape ability assessment using garment images was found to be the highest  $W = 0.933$  and had high correlation with other methods applied. Therefore, it was found that according to this test average ranks, garments drape ability were ranked as follows:  $K2 > K1 > W4 > W2 > W1 > N2 > N6 > W3 > N4 > N5 > W5 > N1$  (see Figure 9.4).



**Figure 9.4** Average ranks of garments images' drape level

It was decided to investigate how these ranked garments were different from each other, as two fabrics or more could be ranked for example as the first and the second, however there are no significant differences between them and they could be ranked in one group with similar drapeability.

Bonferroni's method for multiple paired comparison was used to compare pairs of fabrics using their resulting least significant difference (using the Equations mentioned in Section 9.2.4). A pair of fabrics had no difference, if the difference between them did not exceed the LSD. Bonferroni's least significant range difference for the garment images' drape ability was 0.549 for 66 tests (see Table 9.3) . This means that the value 0.549 could be used as a threshold to determine differences between the fabrics. Therefore, any two ranks differ by at least 0.549 in magnitude were significantly different,  $p < 0.01$ .

**Table 9.3** Calculation of Bonferroni's least significant range difference for the garment images' drapéability

ANOVA						
Source of Variation	SS	df	MS	F	P-value	F crit
Between Groups	2669.14583	11	242.65	283.93	2E-126	1.8308
Within Groups	194.85	228	0.8546			
Total	2863.99583	239				
Bonferroni's LSD						
		alpha			0.0008	
		s pooled			0.9244	
		TINV(p, dfwithin)			3.414	
		k			12	
		n1			66	
		<b>LSD</b>			<b>0.5494</b>	

Paired comparison was carried out by calculating the absolute difference between average value rank of each pair of fabrics. The resultant values are presented in Table 9.4, each cell is the difference between the corresponding fabrics (its column- row). The underlined value indicates that the difference is lower than the predetermined Bonferroni's LSD.

**Table 9.4** Multiple paired comparison using Bonferroni's LSD (Garment images' drapé ability)

Average rank	Fabrics	K2	K1	W4	W2	W1	N2	N6	W3	N4	N5	W5
1.35	<b>K2</b>											
2.05	<b>K1</b>	0.7										
3.7	<b>W4</b>	2.35	1.65									
3.85	<b>W2</b>	2.5	1.8	<u>0.15</u>								
4.2	<b>W1</b>	2.85	2.15	<u>0.5</u>	<u>0.35</u>							
6.3	<b>N2</b>	4.95	4.25	2.6	2.45	2.1						
6.7	<b>N6</b>	5.35	4.65	3	2.85	2.5	<u>0.4</u>					
8.65	<b>W3</b>	7.3	6.6	4.95	4.8	4.45	2.35	1.95				
9.05	<b>N4</b>	7.7	7	5.35	5.2	4.85	2.75	2.35	<u>0.4</u>			
9.65	<b>N5</b>	8.3	7.6	5.95	5.8	5.45	3.35	2.95	1	0.6		
10.4	<b>W5</b>	9.1	8.4	6.75	6.6	6.25	4.15	3.75	1.8	1.4	0.8	
12	<b>N1</b>	10.6	9.95	8.3	8.15	7.8	5.7	5.3	3.35	2.95	2.35	1.55

Table 9.4 was summarised as follows to obtain the following groupings which shows significant and insignificant differences between fabrics assessed. The underlined groups refer to fabrics with insignificant differences.

K2 K1 W4 W2 W1 N2 N6 W3 N4 N5 W5 N1

The groupings imply that there is insufficient evidence to conclude that the mean of garments' drape ability in each group: (W4, W2 and W1), (N2 and N6), (W3 and N4) differ. This means that there is similarity between the drape behaviour of fabrics in the previous assigned groups. However, there was sufficient evidence to conclude that the population mean of drape ability of these groups are different from each other.

From the rankings of garment images assessed, it was noted that the two knitted fabrics tested  $K2 > K1$  had the highest drapeability and the group of (W4, W2 and W1) had lower drapeability than them. With regard to the five nonwoven fabrics evaluated (N1, N2, N4, N5 and N6), it was found that two nonwoven fabrics (N2, N6) had higher drape than two woven fabrics (W3, W5) in the fabrics group tested. Moreover, 4 nonwovens from the five N2, N6, N4 and N5 had higher drapeability than one of the woven fabrics tested W5. N1 had the least drape ability.

It is evident from the groupings that one nonwoven garment (N4) was paired with one woven fabric (W3), which indicated the similarity between them in drape ability. This means that some nonwoven fabrics tested could have better or similar drapeability than some conventional fabrics. These results contradict with the reason preventing apparel makers and consumers from making or wearing a garment made from nonwoven fabrics as it has low drapeability. Therefore, nonwoven fabrics can be proposed to be used in apparel industry.

#### **9.3.4 Drape preference ranking**

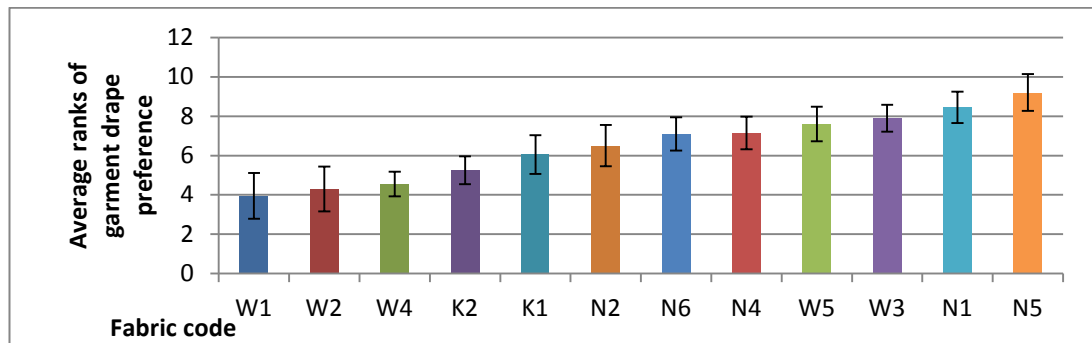
Previous research studied the correlation between fabric drapeability and preference. Negative rank correlation and significance at level higher than 5% was found between drapeability and preference when stiff fabrics were the fashion trend, which affected judges in ranking skirts according to drape preference. Cotton fabrics was preferred to rayon fabrics (cotton was stiffer than rayon), but when two bonded (nonwoven) fabrics were added to the group of fabrics tested, a negative relation still existed but they were not preferred (Cusick 1962). In other studies, drape preference and drape values were found with a positive strong correlation (Collier 1991; Orzada, Moore and Collier 1997).

In this study, it is important to recall the results of Kendall's coefficient of concordance computed for garment drape preference, Kendall's  $W$  was 0.22,  $p \leq 0.0001$ . This means that there was a significant low agreement between judges for drape preference. This means that there was inconsistent evaluation for drape preference, as a low drapeable garment which was preferred by some judges was not preferred by others. This

illustrates the unnecessary desire of a high drape fabric for making garments as low drape fabrics were preferred by some judges.

In this study, the average rank values were used to study drape preference of fabrics assessed. It was found that there was strong positive correlations  $r \geq 0.78$ ,  $p > 0.05$  between drapability rankings and drape preference. This means that high drape fabrics were preferred.

The fabrics were ranked as follows from the most preferred to least: W1 > W2 > W4 > K2 > K1 > N2 > N6 > N4 > W5 > W3 > N1 > N5 (see Figure 9.5).



**Figure 9.5** Average ranks of garment drape preference

It was required to investigate the significance of differences between the garments. Paired comparison tests were carried out by calculating the absolute difference between average rank value of each pair. Bonferroni's method for multiple paired comparison was applied to find the least significant difference of 1.85. This means that if two average ranks differing by at least 1.85 in magnitude, they will be significantly different (see Table 9.5 for Bonferroni's LSD calculation) .

**Table 9.5** Calculation of Bonferroni's least significant range difference for the garment drape preference

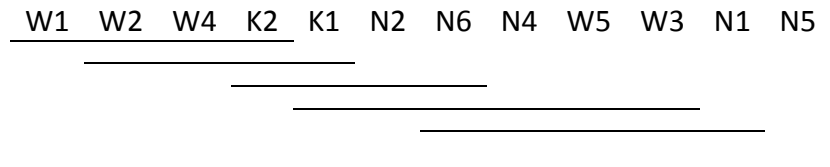
ANOVA						
Source of Variation	SS	df	MS	F	P-value	F crit
Between Groups	639.1	11	58.1	5.96461	1.6E-08	1.83082
Within Groups	2220.9	228	9.74079			
Total	2860	239				
Bonferroni's LSD						
		alpha			0.00076	
		s pooled			3.12102	
		TINV(p, dfwithin)			3.41399	
		k			12	
		n1			66	
		LSD			1.85482	

Resulting values are presented in Table 9.6, each cell is the difference between its corresponding fabrics (its column- row). The underlined value indicates that the difference is less than the predetermined Bonferroni's LSD.

**Table 9.6** Multiple paired comparison using Bonferroni's LSD (Real garment drape preference)

Rank Average	Fabrics	W1	W2	W4	K2	K1	N2	N6	N4	W5	W3	N1
3.95	W1											
4.3	W2	<u>0.35</u>										
4.55	W4	<u>0.6</u>	<u>0.25</u>									
5.25	K2	<u>1.3</u>	<u>0.95</u>	<u>0.7</u>								
6.05	K1	2.1	<u>1.75</u>	<u>1.5</u>	<u>0.8</u>							
6.5	N2	2.55	2.2	1.95	<u>1.25</u>	<u>0.45</u>						
7.1	N6	3.15	2.8	2.55	1.85	<u>1.05</u>	<u>0.6</u>					
7.15	N4	3.2	2.85	2.6	1.9	<u>1.1</u>	<u>0.65</u>	<u>0.05</u>				
7.6	W5	3.65	3.3	3.05	2.35	<u>1.55</u>	<u>1.1</u>	<u>0.5</u>	<u>0.45</u>			
7.9	W3	3.95	3.6	3.35	2.65	1.85	<u>1.4</u>	<u>0.8</u>	<u>0.75</u>	<u>0.3</u>		
8.45	N1	4.5	4.15	3.9	3.2	2.4	1.95	<u>1.35</u>	<u>1.3</u>	<u>0.85</u>	<u>0.55</u>	
9.2	N5	5.25	4.9	4.65	3.95	3.15	2.7	2.1	2.05	<u>1.6</u>	<u>1.3</u>	<u>0.75</u>

Table 9.6 was summarised as follows to obtain the following groupings which shows significant and insignificant differences between fabrics assessed. The underlined groups refer to fabrics with insignificant differences.



The groupings imply that there is sufficient evidence to conclude that (W1 was preferred to K1), (W4 preferred to N6), (K2 preferred to W3) (N2 preferred to N1) and (N4 preferred to N5), in other words that their populations means are different.

However, there was insufficient evidence to conclude that the population mean drape preference for fabrics in the following groups (W1, W2, W4, K2), (W2, W4, K2, K1), (K2, K1, N2, N6), (K1, N2, N6, N4, W5, W3), (N6, N4, W5, W3, N1), (W5, W3, N1, N5) differ.

With respect to nonwoven fabrics, two conventional fabrics W5 and W3 were less preferred than three nonwoven fabrics (N2, N6, N4). Two nonwoven fabrics were least preferred by the observers (N1, N5).



This means that the drapeability of nonwovens could be preferred to conventional fabrics. In addition to the results from the above section that some nonwovens had higher drapeability than some conventional fabrics, it was found that they were preferred as well. These results recommend adopting nonwovens in the clothing industry for making drapeable garments.

### **9.3.5 Correlations between subjective assessment of drapeability and drape coefficient**

Previous researchers found good correlations between objective drape values and subjective assessment of drapeability  $r=0.79$  (Chu, Cummings and Teixeira 1950),  $r=0.83$ ,  $p<0.001$  (Collier 1991),  $r= 0.95$ ,  $p<0.05$  (Orzada, Moore and Collier 1997),  $r=0.86$  (Uçar *et al.* 2004),  $R^2= 0.9$ (Agarwal, Koehl and Perwuelz 2011)

In this study, drape coefficient (measured in Chapter 7) was found to have a strong negative correlation with subjective drapeability tests  $r > 0.82$ ,  $p < 0.05$ .

## **9.4 Summary**

Drapeability was assessed using real materials and images for both fabrics and garments. Assessment of fabric drapeability using either material/method was found to have high agreement between judges. These methods were found highly correlated with each other. Therefore, it was concluded that using either method is representative for fabric drapeability assessment subjectively. The drapeability of some nonwoven fabrics evaluated was similar to other conventional fabrics but others were lower than them.

With regard to drape preference, although there was low agreement between judges for drape preference, if average rank values resulting from drape preference were to be used, some nonwovens were grouped with some conventional fabrics (insignificant differences between them) or more preferred than them.

## **Chapter 10**

### **Prediction of fabric and garment drapeability**

#### **10.1 Introduction**

Drape is a complex fabric deformation as it is affected by many different factors. In recent years, several research studies were carried out investigating the relationship between a fabric's properties and its appearance in terms of drape. Statistical analyses were carried out to find the key properties affecting drape. These studies produced different theoretical prediction equations for fabric drape. Several equations developed for calculating drape coefficient and other drape values were used successfully as alternative objective measurement for experimental drape values (measured on a drapemeter). Also, there is another advantage for this theoretical method, that these equations were undertaken by many researchers interested in developing theoretical approaches to predict and simulate fabric and garment drape such as CAD-CAM systems for clothing design and manufacture. This approach is based on using fabric physical and mechanical properties as input parameters to calculate and simulate fabric drape shape.

Most of those studies predicted a fabric drape coefficient or its alternative drape values from mechanical properties measured on the Kawabata Evaluation System for fabrics and some were dependent on the FAST system properties. Other studies were based on predicting the subjective rating of fabric drape from drape values measured. Several physical and mechanical properties were suggested as contributors to the drape of knitted and woven fabrics.

Since, in this study a new combination of drape values (measured by Drape GUI) was introduced, it was decided to study the relationship between them and drape rank scores. As a result of this investigation new equations for predicting drape rank scores were derived.

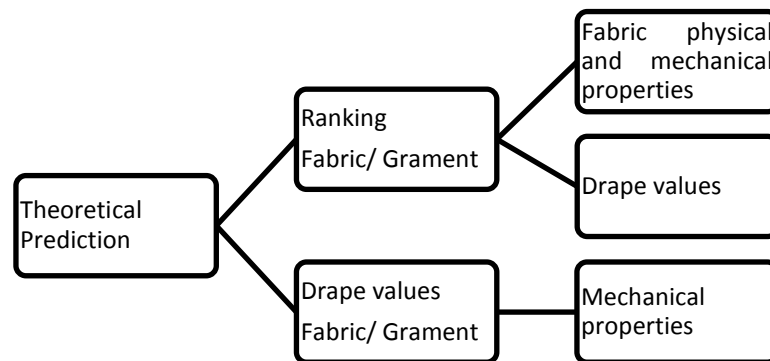
Since the literature lacks information concerning the physical and mechanical properties affecting the drape of nonwoven fabrics, as the few papers found which included some bonded-fibre fabrics was by (Backer and Petterson 1960; Cusick 1962; Cusick *et al.* 1963; Hearle, Michie and Stevenson 1964; Cusick 1965; Michie and Stevenson 1966; Zeronian and Wilkinson 1966; Sengupta and Majumdar 1971; Newton and Ford 1973; Lamb and Costanza 1975; Floyd 1975; Koenig and Kadolph 1983; Patel and Warner 1994). Since then, there were no studies carried out on nonwovens'

drape, although there has been substantial progress in nonwoven fabric production and properties with regard to apparel end use. Therefore, it was decided to study the factors affecting a fabric group including nonwoven fabrics and compare between them and factors affecting conventional fabrics in terms of developing equations for theoretical prediction of drape. It was aimed to determine whether the same properties affecting conventional fabrics have a role in nonwovens' drape. Therefore, in addition to testing the whole group of fabrics two sub groups were considered namely conventional fabrics and nonwovens.

Since, there were differences found between drape values for fabric and garments measured using image analysis technique with respect to their correlation with rank scores, comparisons between factors' contributions to fabric and garment ranking in terms of drape values and mechanical properties were carried out.

As a new combination of drape values was proposed previously in this study, it was found that predicting these parameters using mechanical properties of fabrics was important.

Therefore, in this chapter, fabric properties affecting drape were investigated in the form of a direct quantitative evaluation methods. The present work was also undertaken to include comparison of fabric and garment drape in the light of the proposed parameters see Figure 10.1 for a summary of the investigations carried out.



**Figure 10.1** Prediction of fabric and garment drape

## 10.2 Regression analysis

Simple (bivariate) regression analysis includes several techniques and methods used to model the relationship between two variables (dependent DV and independent IV). So, it is used to predict a dependent variable in the

conditions controlled by an independent variable. Therefore, regression analysis is used for prediction and forecast.

Regression analysis produces a regression line (best line fit/trend line) for two variables plotted on a scatter chart. It passes through the points of the scatter chart to give the closest fit to them. This line is presented using Equation 10.1:

$$Y_{\text{Dependent}} = b_{\text{slope}}X_{\text{independent}} + a_{\text{intercept}} \quad 10.1$$

where Y is a dependent variable which is presented on the vertical axis on the chart and also called “ criterion”, X is an independent variable, also called predictor and presented at the horizontal axis on the scatter chart. The intercept (a) is the point at which the regression line cuts the vertical axis. The slope (b) (also called the regression coefficient) is the gradient of the regression line. The closer the scatter plots to the regression line are, the higher the accuracy of predicting a dependent variable is. Both the correlation coefficient and the regression line illustrate the two variables' relationship but they are used in different ways.

Multiple regression and correlation are extensions of regression analysis. However, it includes several different X independent variables and only one Y dependent variable. This method of regression indicates the best predictor of the Y variable, then the next best predictor until all the X variables are screened to result the most accurate prediction parameters. There are different types of multiple regression analyses, the method applied is chosen according to the desired output.

There are two main aims for multiple regression, the first is to estimate the minimum number of predictors for an independent variable. However, if two good predictors are highly correlated with each other, this means that only one of them would be used to predict the criterion. Another aim is to investigate whether a predictor remains significantly related to the independent variable while involving new dependent variable/s.

In multiple regressions (MR), the regression equation is similar to the simple regression, except there are several predictors and each predictor has its own partial regression coefficient (see Equation 10.2):

$$Y = a + \sum_{i=1}^n b_i X_i \quad 10.2$$

where n is the number of predictors.

A partial regression coefficient expresses the relationship between each predictor and criterion and other predictors in the regression equation. It illustrates each predictor's contribution to the prediction of IV.

Multiple correlation is measured by the coefficient of multiple determination  $R^2$  which ranges between 0 (no correlation) and 1 (perfect correlation).

### 10.2.1 Model selection methods

The number of regression equations that could be produced in MR increases exponentially with the number of predictors. Entering all IV s in the equation is called standard multiple regression. When using big numbers of predictors, many regression equations are derived. Obtaining all subsets for predicting IVs produces some difficulty in arranging them according to the best subset. So, when there are large numbers of IVs, a number of different approaches are suggested to avoid looking to all potential equations and selecting and testing the predictors. There are different methods here are some of them:

- Hierarchical (Blockwise) selection: The predictors are entered in the regression equation singly or in blocks based on some practical or theoretical consideration.
- Forward selection: statistical criteria are used to include and exclude the predictors involved, especially if our objective is to derive the best equation to calculate IV. It starts with entering the best predictor for the DVs with significant correlation with the IV. It then adds the predictor improving the prediction the most. The addition process is continued until all the IVs are tested. The disadvantage of this method is that once a variable is added to the model it stays in the model regardless of its relation with other variables added later on.
- Backward elimination: This method is the reverse of the forward selection method. It starts with all predictors considered and then removes the one with the smallest significance. The process continues until no more variables are removed. This method has the same disadvantage of the forward selection method as it does not take into consideration the significance of each predictor with respect to its intercorrelation with other variables in the regression.
- **Stepwise selection:** This method is a combination of forward and backward selection methods. In this method, the predictor with the highest correlation is entered first into the regression equation, if it has significant correlation with the DV. The following predictor is entered into the equation

as well if it has the highest significant partial correlation. The first predictor is tested for its significance after including the second predictor. If it (first predictor) is not significant, it is removed from the equation. The process of entering and removing the predictors is repeated and continued until all predictors are tested and no more variables are added or removed.

This method is the one used in the present study as it was used repeatedly in previous theoretical drape prediction studies. Another important reason for applying this method was that it does not have the previous methods' (Forward – Backward) disadvantages.

### **10.2.2 Regression analysis performed**

In this study, four regression analysis were conducted for modelling and analysing the relation between drape rank scores (IV) and the drape values (DVs), between drape rank scores (IV) and the mechanical properties, and between the drape values and the mechanical properties.

In each regression analysis, the correlation coefficients between IV and DV/s were calculated initially to investigate the relationship between them and the results were plotted in charts. Then, the stepwise regression analysis was performed by using IV and DVs as input data for the software used.

SPSS software was used to carry out the stepwise regression analysis with the following criteria: Probability-of-F-to-enter an independent variable was to be less than or equal to 0.05, Probability-of-F-to-remove an independent variable to be higher than or equal to 0.1. The results of the regression analysis are shown in tables and include the following: Dependent Variable (criterion predicted), independent variables (predictors) include constant (intercept which accounts for the random variation in the data) and partial regression coefficient/s (B unstandardised coefficient/s) and (Beta standardised coefficient/s which show which of the independent variables have a greater effect on the dependent variable in a multiple regression analysis, t is the t statistic, sig is the significance level of the variable also called p-value,  $R^2$  is the proportion of the total amount of variation in the data which can be explained by the fitted model (see Appendix E for Regression analysis results) .

Beta coefficients are standardised to make their variance equal to 1. They represent the relationship between the standard deviations of DVs and IV. In other words, they represent the amount of standard deviation of DV changes for each standard deviation increase in IVs. They show and compare the effect of different IVs measured in different units on DV. Therefore, the standardised coefficients obviate the independent variable's scale of units, which makes comparisons easy. So, they are used and plotted on a bar

chart at the end of each regression analysis conducted to show the importance and contribution of DV/s to predict IV.

## **10.3 Results and discussion**

### **10.3.1 Prediction of drape rank scores using the drape values**

Before performing the stepwise regression analysis, the correlations between the average drape values (independent variables) measured employing the “Drape” GUI for fabrics’ and dresses’ images (see section 8.2.2), and rank scores of the respective images (measured in Chapter 9) were calculated (see Figure 10.2). In order to study the correlation dependence on fabric form (fabric/garment) and type (conventional/nonwovens), the correlations were calculated for the “all” group of the tested fabrics and garments, moreover, the correlations of two subgroups i.e. conventional and nonwoven fabrics and garments and their drape rank scores were calculated (see Figure 10.3 and Figure 10.4). Critical correlation coefficient for  $n$  (number of fabrics measured) = 12 is  $\pm 0.57$ .

With respect to the fabric form, in the all groups (fabrics and garments), it was found that there were significant contradictory (reverse direction) correlations. In other words there were some significant correlations in the fabrics’ group in the reverse direction of the garments’ group. Circularity, area, peaks no, *WA CV*, *WL CV*, *WH/WL*, Fourier and F/O had correlations in the same direction, however the rest of the parameters had contradictory/reverse directions. The garment drape values had almost more significant parameters than fabric drape values.

In conventional groups (fabrics - garments), garment drape values had higher significant correlations with the rank scores than fabric. Contradictory correlations’ directions were found in Perimeter, Symmetry (Face/ back), Fourier, F/O and D/O; however the rest of the drape values had relations in similar directions.

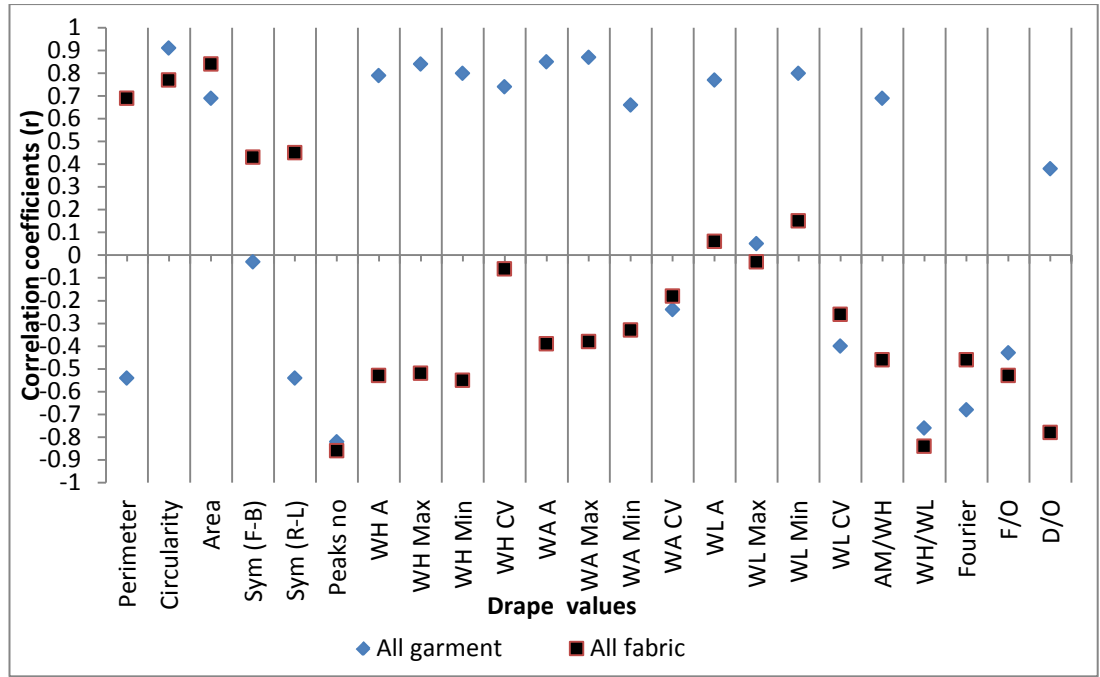


Figure 10.2 Correlation coefficients (r) of image results and the corresponding rank scores.

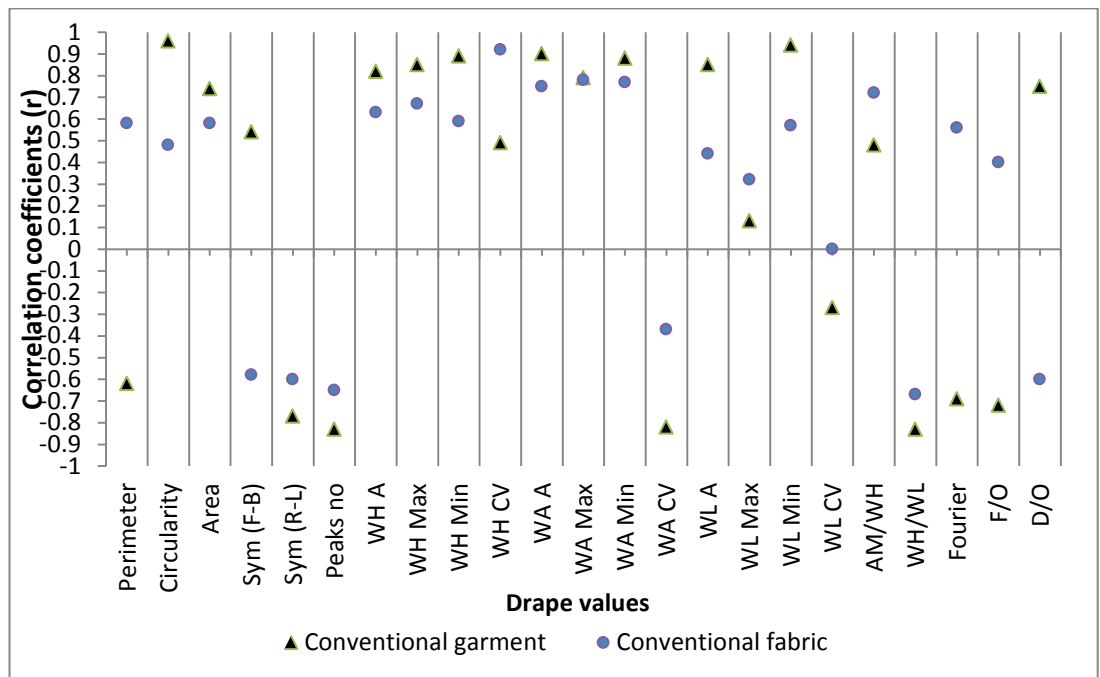
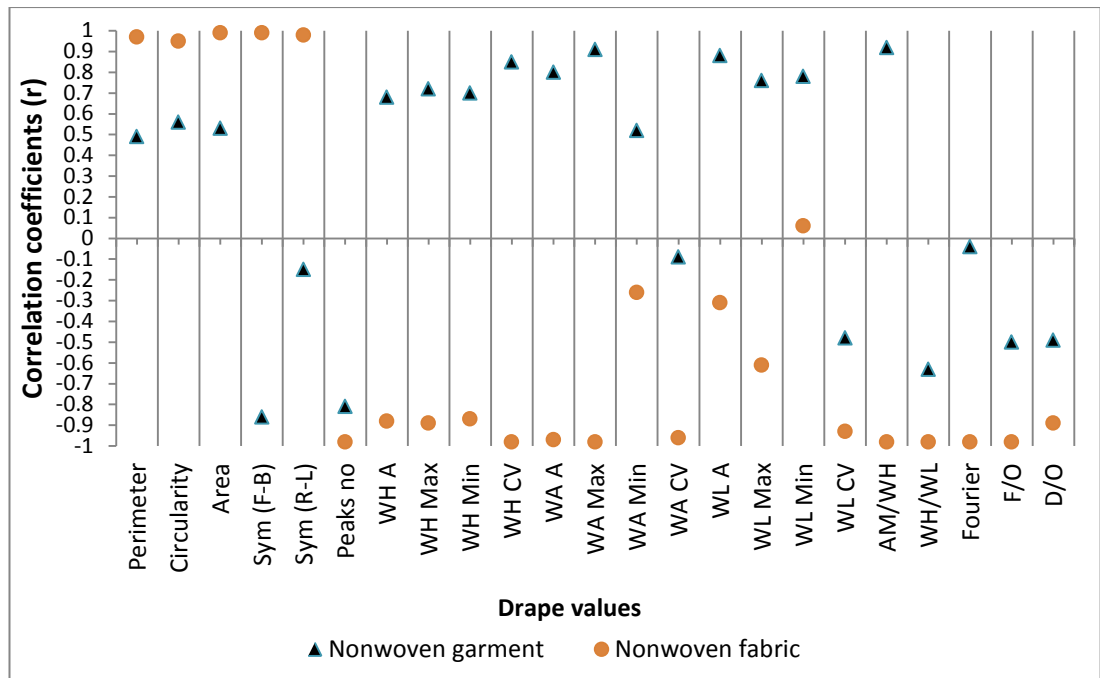


Figure 10.3 Correlation coefficients (r) of image results and the corresponding rank scores.



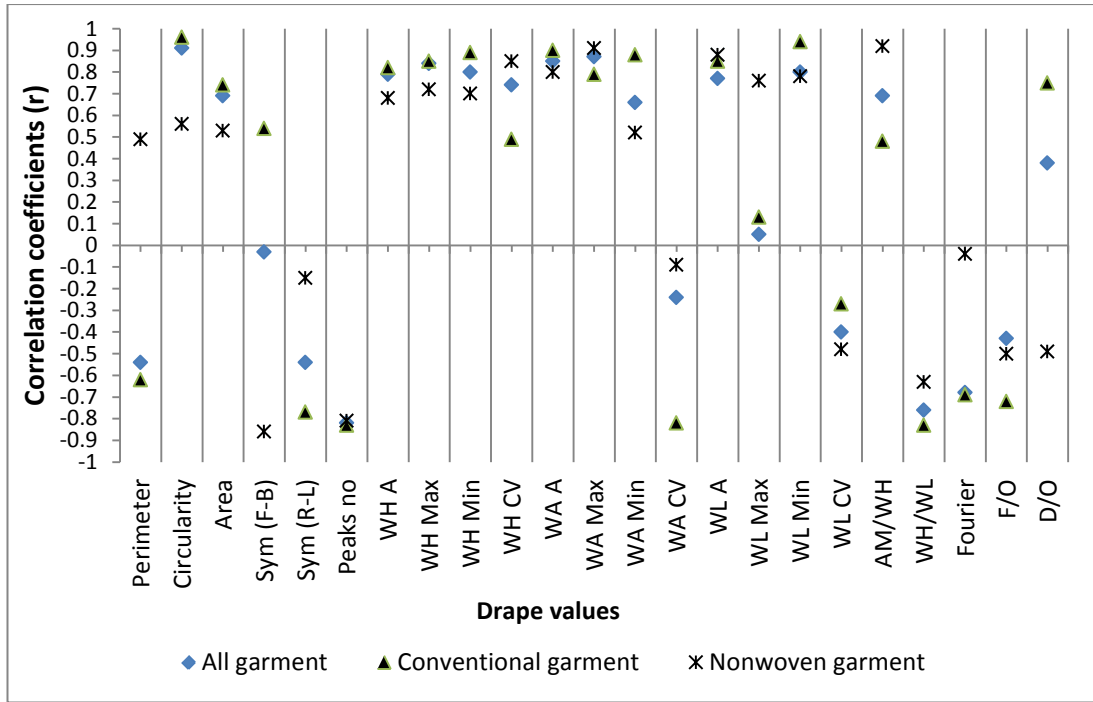


**Figure 10.4** Correlation coefficients (r) of image results and the corresponding rank scores.

From the above results, most of the drape values' correlation with rank scores was contradictory in all and nonwoven groups for fabrics and garments. In the conventional group most of the correlations were in the same direction. There were different levels of significance; in all and conventional groups the significance levels were higher in the garments groups than fabrics. However in the nonwovens group the fabric group had higher significance.

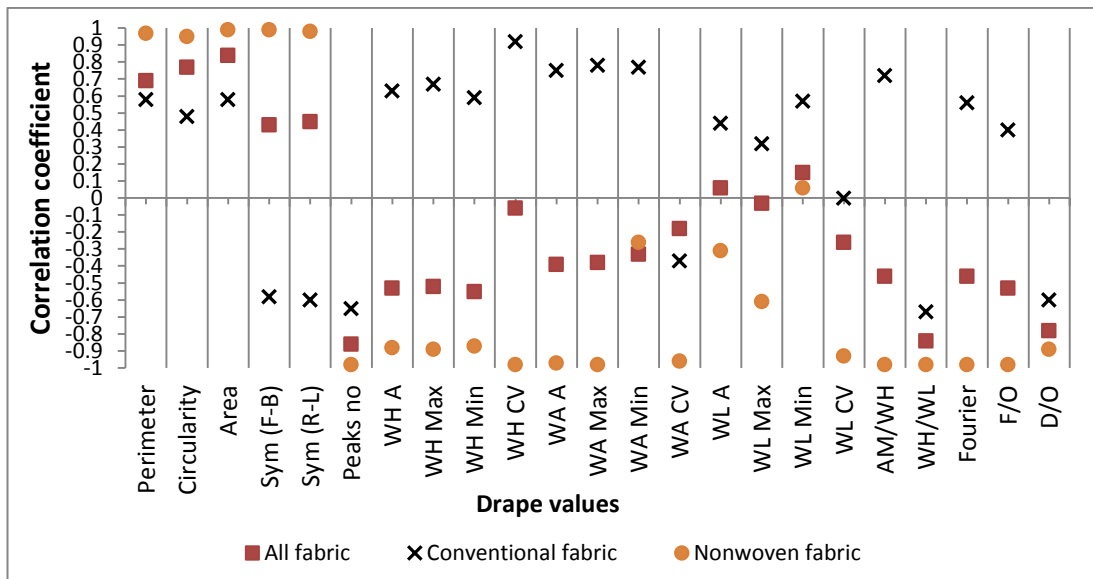
The contradiction in relations direction between rank scores and, garments and fabrics in all, conventional and nonwoven groups indicated the importance of using the garment form in studying drapeability rather than the fabric form. As correlations direction and significance was dependent on fabric form.

With respect to the **fabric type** (see Figure 10.5 and Figure 10.6), in the garment samples tested, it was found that the conventional fabrics had the highest significant correlations with rank scores followed by the all group and the nonwoven garments group had the least significance levels. There were contradictory correlations in perimeter, area and D/O.



**Figure 10.5** Correlation coefficients (r) of image results and the corresponding rank scores.

In the fabric groups' correlations (Figure 10.6), the nonwoven fabrics had generally the highest levels of correlation significance in most drape values and contradicted with all and conventional groups. Perimeter, Circularity, Area, *WA CV*, *WH/WL* and *D/O* correlations were in the same direction for all, conventional and nonwoven groups, although nonwovens had the highest significance levels.



**Figure 10.6** Correlation coefficients (r) of image results and the corresponding rank scores.

All previous results indicated the effects of fabric form (fabric/garment) and type on the correlation between rank scores and the drape values. This means that prediction of garment drape profile and ability are dependent on fabric form and type. Therefore it was expected to obtain different regression equations for each fabric form and type as correlations differ according to fabric form.

It was found that the number of nodes and *WH/WL* (node severity) were significant in all sub groups forms and types.

The correlations between the drape values (DV) were investigated. There were several interrelations between DV s which were already correlated with rank scores.

Therefore, **Stepwise regression analysis** was performed for garment and fabric drapability rankings on drape values measured by Drape GUI to find the basic parameters that could best predict fabric and garment drape rank scores. The rank scores of fabrics' and garments' images were predicted using their correspondent average drape values calculated in Chapter 8. Table 10.1 and Table 10.2 list the data obtained from the regression analysis of garments and fabrics images rank scores on the drape values measured for the respective images.

**Table 10.1** Regression analysis of garments' images rank scores on the drape values measured for the respective images

Multiple regression equation	R <sup>2</sup>
Rank (All) = -9.721 + 27.607 Circularity + 0.122 <i>WLMIN</i>	0.93
Rank (Conventional) = -14.131 + 25.329 Circularity + 0.280 <i>WLMIN</i> -1.954 <i>WAA</i> + 31.031 <i>D/O</i> + 0.008 Fourier + 0.005 <i>WAMAX</i>	1
Rank (Nonwovens) = -31.286 + 121.706 <i>AM/WH</i> -1.431 <i>WAMIN</i>	0.99

**Table 10.2** Regression analysis of fabrics' images rank scores on the drape values measured for the respective images

Multiple regression equation	R <sup>2</sup>
Rank (All)= 10.072 - 0.731 Peaks no	0.74
Rank (Conventional)= 0.569 + 264.043 <i>WHCV</i> - 0.012 <i>WLMAX</i> (R <sup>2</sup> = 0.98)	0.98
Rank (Nonwovens)= -26.901 + 0.056 Area	0.98

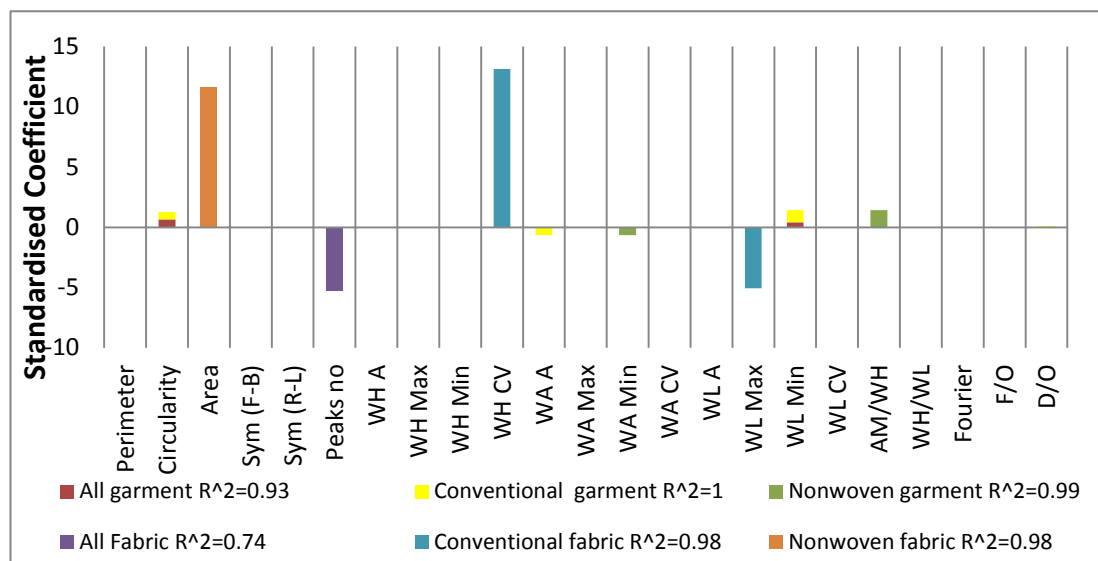
It is evident from Table 10.1 and Table 10.2 that the predictors differ according to the fabric form and type.

Circularity and *W*LMin were the best predictors in All/Garment equation with  $R^2 = 0.93$ . CIRC, WL Min, WAA, D/O, Fourier and WAMax played an important role in the Conventional/Garment equation  $R^2 = 1$ , however *AM/WH* and WAMin were significant predictors in the nonwoven garment equation  $R^2 = 0.99$ .

In the equations derived for fabric prediction, only the number of peaks parameter significantly predicted the ranking of All/fabrics with  $R^2 = 0.74$ . However, the  $R^2$  of conventional and nonwoven fabrics' stepwise regression equations were higher with 0.98. *WHCV* (Wave height coefficient of variation) and *WLMAX* (Maximum Wave length) had the main role of theoretically calculating the ranking of conventional fabrics. Only the area parameter contributed to the prediction of nonwovens' drapability. This means that different type of fabric measured (fabric or garment) have different best predictors.

The regression analysis results indicate that fabric and garment forms have different correlated predictors (drap values). This shows that the prediction of garment drap will be more accurate employing a system using garment drap values rather than the same garments' fabric drap values.

It is evident from Table 10.1, Table 10.2 and Figure 10.7 that the sub groups conventional and nonwovens fabrics and garments were more precisely predicted using their independent variables rather than the general regression equations. The coefficients of determination of the sub groups are higher than the all group. Figure 10.7 illustrates the contribution of each parameter in predicting when using the standardised coefficients.

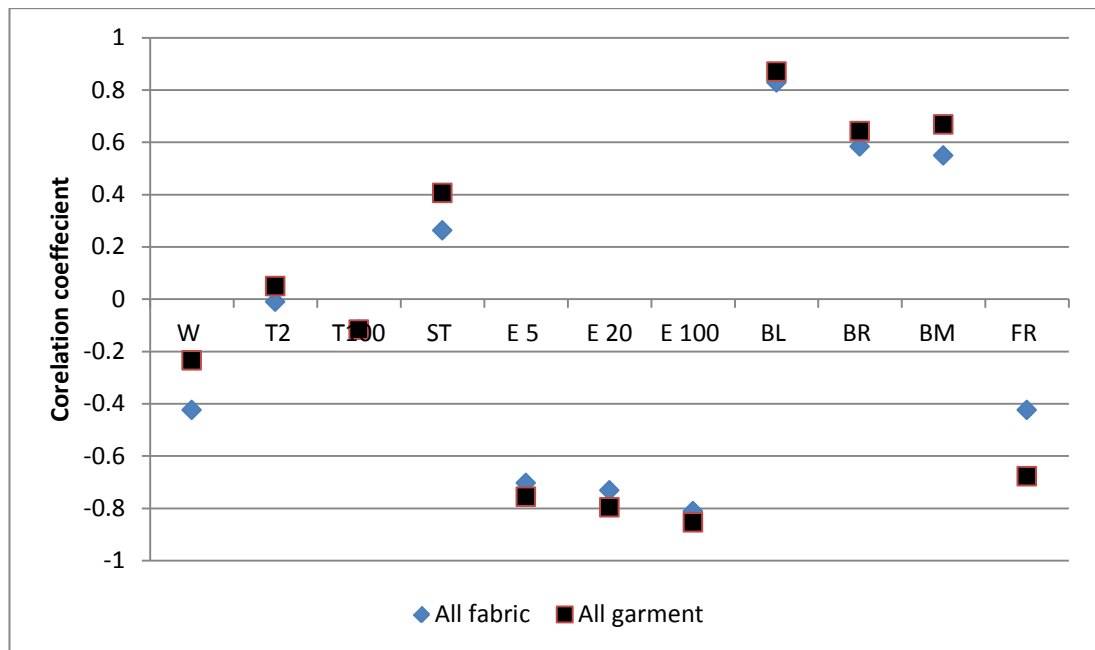


**Figure 10.7** The best drap values predictors of each group of fabric form and type drap rank scores

### 10.3.2 Prediction of fabric and garment drapéability using the mechanical properties

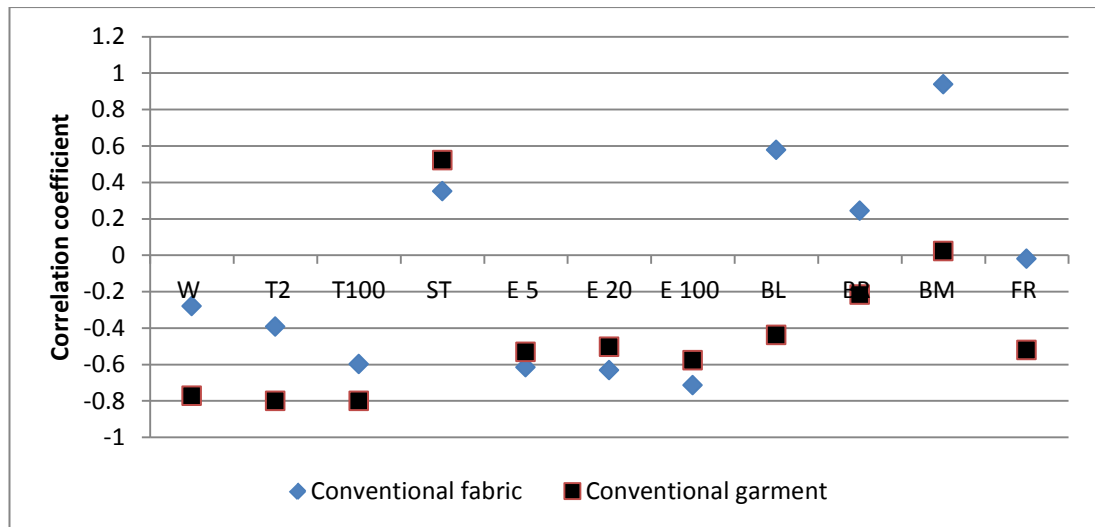
The correlations between the mechanical properties measured (except the shear rigidity which showed virtually infinite values for two woven and all the nonwoven fabrics) and garment and fabric rank scores and the interrelations between these properties were investigated. Results of correlation coefficients are plotted in Figure 10.8, Figure 10.9 and Figure 10.10.

With respect to the fabric form (fabric-garment), in the all groups (see Figure 10.8), it was found that the mechanical properties had higher significant correlations with rank scores of garments than fabrics. The extensibility parameters ( $E5$ ,  $E20$  and  $E100$ ), bending length, rigidity and modulus had significant correlations in the all garment group. Thickness and weight did not have significant correlations with rank scores.



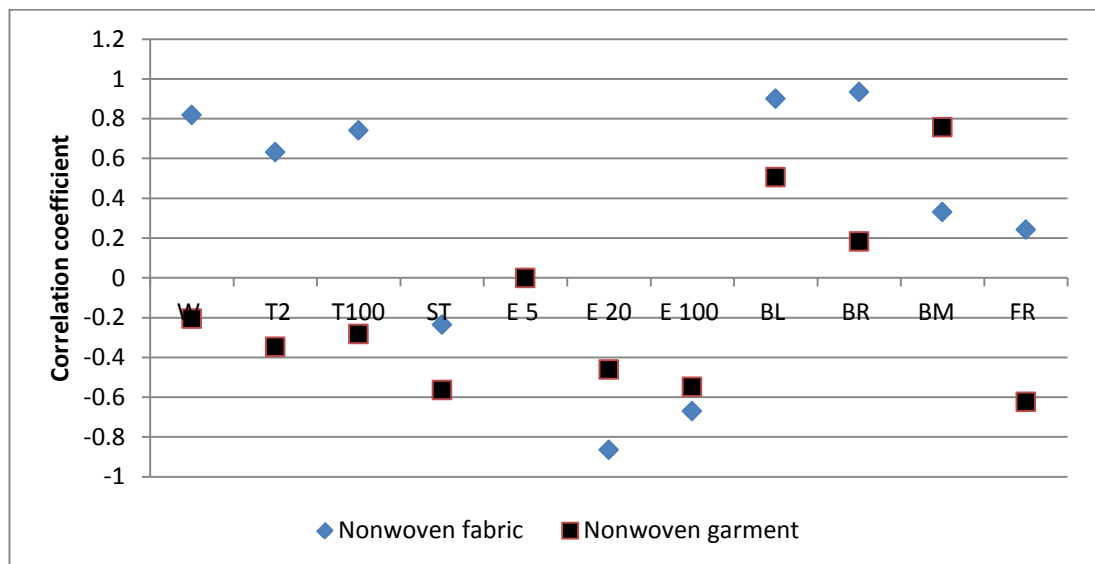
**Figure 10.8** Correlation coefficients between rank scores and the mechanical properties for all group of samples

In the conventional groups, (see Figure 10.9),  $T2$ ,  $T100$  and weight had significant correlations in garment rank scores. In the fabric group  $T100$  had significant correlation with the images' rank scores. The extensibility properties  $E5$ ,  $E20$  and  $E100$  of the garments had significant correlations, but this was not the case in the fabrics group except  $E100$ . The bending length had significant correlation in the fabric group. Bending rigidity and formability had no significant correlations in both groups. Fabric bending modulus had significant correlations but this was not true for the garment correlations.



**Figure 10.9** Correlation coefficients between rank scores and the mechanical properties for conventional samples.

In the nonwovens group (Figure 10.10), it was found that *W*, *T2*, *T100*, *BL*, *BR*, *E20* and *E100* had significant correlations with rank scores in the garment samples. Two properties; namely *BM* and *FR* correlated significantly in fabric nonwovens with rank scores. Most of the properties had significant correlations in the garment samples rather than fabric correlations. These results show the importance of using garment form image analysis for nonwovens.



**Figure 10.10** Correlation coefficients between rank scores and mechanical properties for nonwoven samples.

The difference between correlations' directions and significance levels for garments and fabrics drape values for all, conventional and nonwoven groups again shows the dependence of drape rank scores on fabric form.

Generally, the garment form produced higher significance correlations with drape rank scores than the fabric form which put forward using the garments rather than fabrics for more significant correlations. The interrelations between mechanical properties were investigated in terms of correlation coefficients between them (see Table 10.3). There were found significant correlations between thickness (*T2* and *T100*) and weight. There were significant correlations between extensibility and bending properties except bending modulus.

**Table 10.3** Correlations between mechanical properties

	<i>W</i>	<i>T2</i>	<i>T100</i>	<i>ST</i>	<i>E 5</i>	<i>E 20</i>	<i>E 100</i>	<i>BL</i>	<i>BR</i>	<i>BM</i>
<i>T2</i>	<u>0.73</u>	-	-	-	-	-	-	-	-	-
<i>T100</i>	<u>0.64</u>	<u>0.93</u>	-	-	-	-	-	-	-	-
<i>ST</i>	0.41	0.45	0.10	-	-	-	-	-	-	-
<i>E 5</i>	0.53	0.12	0.27	-0.34	-	-	-	-	-	-
<i>E 20</i>	0.51	0.11	0.25	-0.33	<u>1.00</u>	-	-	-	-	-
<i>E 100</i>	0.54	0.19	0.32	-0.26	<u>0.90</u>	<u>0.94</u>	-	-	-	-
<i>BL</i>	-0.26	0.14	0.07	0.21	<u>-0.78</u>	<u>-0.82</u>	<u>-0.86</u>	-	-	-
<i>BR</i>	0.00	0.35	0.37	0.06	-0.56	<u>-0.61</u>	<u>-0.62</u>	<u>0.89</u>	-	-
<i>BM</i>	-0.33	-0.31	-0.34	-0.05	-0.44	-0.47	-0.54	<u>0.68</u>	0.50	-
<i>FR</i>	0.48	0.08	0.08	0.05	<u>0.59</u>	<u>0.61</u>	0.60	<u>-0.63</u>	-0.45	<u>-0.60</u>

Stepwise regression analysis was conducted for garment and fabric rankings on the mechanical properties measured in Chapter 6 to find the basic mechanical properties that could best predict fabric and garment drape rank scores (see Table 10.4 and Table 10.5 for regression analysis results). The rank scores of fabrics and garments were predicted using their corresponding average drape values calculated in Chapter 8.

It is evident from Table 10.4 and Table 10.5 that the predictor combinations differ according to the fabric form and type.

The bending length was a good predictor for all and conventional garments drapeability ( $R^2 = 0.76$  and  $0.88$  respectively). In the nonwoven garments no independent variables entered into the regression equation which shows insignificant correlation between the mechanical properties and nonwovens garment rank scores.

In the fabrics regression analysis, it was found that bending length and rigidity were the best contributors for all fabric rank scores. However in conventional fabric regression, bending rigidity and *E100* had the major role in illustrating the fabric drape rank scores. In the nonwoven fabric group, the

bending rigidity predicted the fabric drape of nonwovens with strong multiple coefficient of determination ( $R^2 = 0.87$ ).

Again the fabric type and form affected the mechanical properties in the prediction equations. These results indicate the point of different predictors for different fabric form (fabric/garment) and/or type (All / conventional / nonwovens).

**Table 10.4** Regression analysis of garments' images rank scores on the mechanical properties measured for the respective images

Multiple regression equation	$R^2$
Rank (All)=-0.568 + 0.313 BL	0.76
Rank (Conventional) = -2.043320 + 0.395901 BL	0.88
Rank (Nonwovens) (No equation derived)	

**Table 10.5** Regression analysis of fabrics' images rank scores on the mechanical properties measured for the respective images

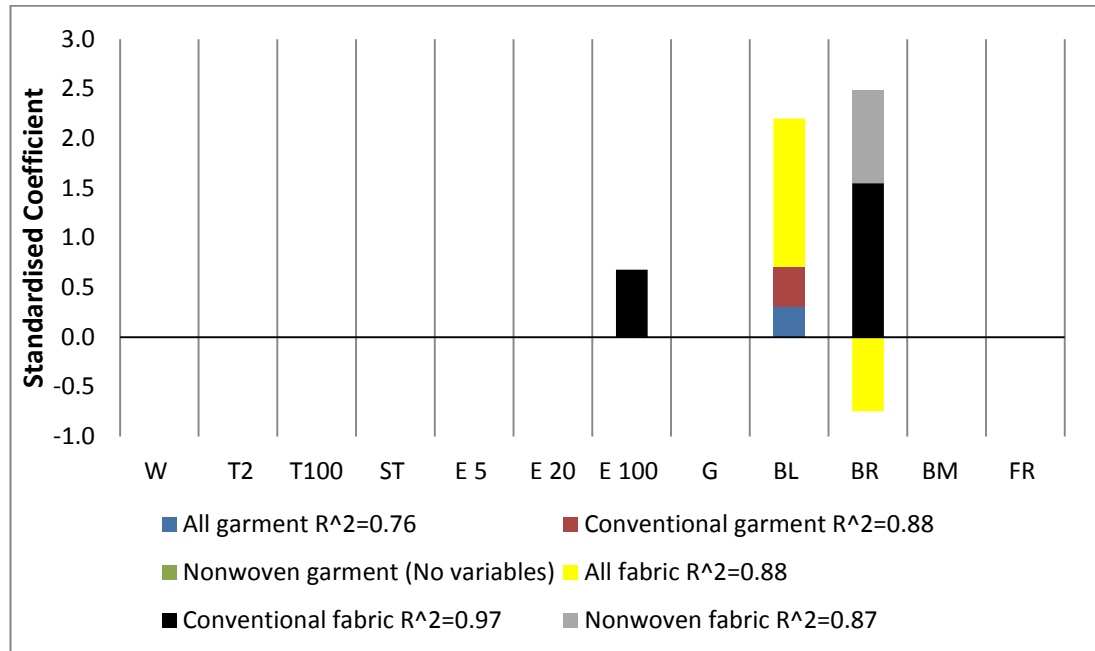
Multiple regression equation	$R^2$
Rank (All)= -3.178 + 0.534 BL - 0.096 BR	0.88
Rank (Conventional) = -2.566 + 0.106 BR + 0.220E100	0.97
Rank (Nonwovens) = 7.279 + 0.065 BR	0.87

It is obvious from Figure 10.11 that  $E100$ ,  $BL$  and  $BR$  played an important role in predicting the drape amount of all, conventional fabric and garment groups and nonwoven fabric group. However no independent variables were effective for nonwoven garment drape. This means that, for the tested garments no mechanical property was significantly affecting the rankings of garment drape.

In the fabric equations,  $BL$  and  $BR$  were the essential properties for the all fabrics group tested with  $R^2 = 0.88$ . In the conventional fabric equation, the bending rigidity and  $E100$  (extensibility at 100 g/cm<sup>2</sup>) were the significant predictors for drape amount ranking with  $R^2 = 0.97$ . The bending rigidity was the only parameter significantly correlated with nonwoven fabrics drapeability with  $R^2 = 0.87$ .



Figure 10.11 identifies the mechanical properties' best predictors of each group (fabric and garment) and type drape rank scores. Generally, *E100*, *BL* and *BR* were the best predictors for the variety of combinations for different groups.



**Figure 10.11** The mechanical properties best predictors of each group (fabric and garment) and type drape rank scores

### 10.3.3 Prediction of the drape values using the mechanical properties

A new combination of drape parameters was proposed earlier in this study and was found to correlate with drape rank scores. It was decided to carry out a stepwise regression analysis to predict these drape values using the mechanical properties (see Table 10.6, Table 10.7 and Table 10.8).

In Basic characteristics (Table 10.6), *W*, *T2*, *T100*, *BL*, *BR*, *FR*, *E5* and *E100* were good predictors for garment and fabric parameters. The circularity was best predicted using the bending length. Garment Area was predicted using only the *BR*; however the fabric Area was dependent on *E100*, *T2* and *FR*. The symmetry (face and back) of the garment images was not able to be predicted. However, the symmetry (Left and right) was predicted with weak  $R^2 = 0.42$  using *BR*. Fabric symmetry (face/back) and (right / left) were predicted with high accuracy ( $R^2 = 0.95$ ) using *FR*, *T100* and *W*. *E100* efficiently predicted the garment number of peaks ( $R^2 = 0.81$ ). The *BL*, *E100*, *E5* and *T2* were included in fabric peaks number equation and produced higher  $R^2 = 0.99$ .

**Table 10.6** Multiple regression equations of fabrics and garments drape values (Basic characteristics) prediction using the mechanical properties

	Independent variable/s	R <sup>2</sup>	Independent variable/s	R <sup>2</sup>
<b>Perimeter=</b>	183.580 + 4.578 E5	<b>0.74</b>	96.886-0.414 E100	<b>0.68</b>
<b>Circularity=</b>	0.262 + 0.008 BL	<b>0.9</b>	0.347+0.017BL	<b>0.79</b>
<b>Area=</b>	1147.191 + 5.795 BR	<b>0.62</b>	534.845-19.051E100+336.777T2- 77.338FR	<b>0.99</b>
<b>Sym F/B=</b>	No variables.		0.913-.084FR+0.482T100-0.001W	<b>0.95</b>
<b>Sym L-R=</b>	0.645 -0.002 BR	<b>0.42</b>	0.883-0.115FR+0.575T100-0.001W	<b>0.95</b>
<b>Peaks no=</b>	4.919 +0.268 E100	<b>0.81</b>	7.754-0.184BL+0.511E100-0.616E5- 2.753T2	<b>0.99</b>

The wave measurement parameters were predicted using the mechanical properties see the regression equations in Table 10.7. The most obvious observation was that no variable entered the regression equations in fabric analysis except T100 which was involved in WA Max with weak correlation  $R^2 = 0.37$ . These results could indicate the importance of predicting wave measurements which are very important for redrawing/reconstructing drape profile using garment images rather than fabric images.

*BL* and *W* were good predictors for *WH A*, Max and Min. *WH CV* had low  $R^2 = 0.54$  using *FR*. *WA MAX* (Wave amplitude maximum) equation involved the *BL* as an independent variable. *WL A* and Min were predicted using *BM* with weak  $R^2 = 0.52$  and  $0.46$  respectively. *E5* and *E100* contributed to *WL CV* with good  $R^2 = 0.8$ .

**Table 10.7** Independent variables of the mechanical properties for predicting fabrics and garments drape values (Wave measurements)

	Independent variable/s	R <sup>2</sup>	Independent variable/s	R <sup>2</sup>
<b>WH A=</b>	15.252 + 0.175 BL + 0.014 W	<b>0.81</b>	No variables	
<b>WH Max=</b>	16.948+0.202BL+0.014W	<b>0.77</b>	No variables	
<b>WH Min=</b>	13.936+0.143 BL+0.011 W	<b>0.74</b>	No variables	
<b>WH CV=</b>	0.107-0.035FR	<b>0.54</b>	No variables	
<b>WA A=</b>	4.761-0.098E100	<b>0.53</b>	No variables	
<b>WA Max=</b>	3.960+0 .122BL	<b>0.77</b>	2.308-3.321T100	<b>0.37</b>

<b>WA Min=</b>	3.163 -2.452FR	<b>0.35</b>	No variables
<b>WA CV</b>	No variables were entered into the equation.		No variables
<b>WL A=</b>	53.046+ 0.209BM	<b>0.52</b>	No variables
<b>WL Max</b>	No variables were entered into the equation.		No variables
<b>WL Min=</b>	24.069+ 0.123 BM	<b>0.46</b>	No variables
<b>WL CV=</b>	0.521+ 0.150E5 -.030 E100	<b>0.80</b>	No variables

*AM/WH* were predicted with higher accuracy for the fabric group ( $R^2 = 0.79$ ) than the garment group ( $R^2 = 0.41$ ) using different parameters, namely T100, *BM* and *W*, however only *FR* had a role in predicting *AM/WH* of garments. Also, fabric *WH/WL* and Fourier parameters were more precisely predicted for fabrics rather than garments.

**Table 10.8** Independent variables of the mechanical properties for predicting fabrics and garments drape values (wave analysis and Fourier)

	Independent variable/s	R <sup>2</sup>	Independent variable/s	R <sup>2</sup>
<b>AM/WH=</b>	0.374+ -0.074FR	<b>0.41</b>	0.224- 0.496T100+0.000BM+0.001W	<b>0.79</b>
<b>WH/WL=</b>	0.378+0.014 E100	<b>0.62</b>	0.446-0.012BL	<b>0.88</b>
<b>Fourier=</b>	106.910+ 1.523 E20	<b>0.51</b>	27.985-69.329T100+27.574FR	<b>0.80</b>
<b>F/O=</b>	No variables		0.003-0.007T100+0.003FR	<b>0.82</b>
<b>D/O=</b>	0.252-0.002 E100	<b>0.39</b>	0.700-0.015BL	<b>0.67</b>

### 10.4 Summary

In this Chapter new equations were derived for predicting garment and fabric rank scores using proposed drape values and the mechanical properties. The drape values used in predicting drape rank scores were Circularity , Area, Peaks no, *WL MAX*, *WL MIN*,*WHCV* ,*WAA* ,*WAMAX*, *WAMIN*, *AM/WH*,*D/O*, Fourier. The mechanical properties employed in predicting rank scores were generally *E100*, *BL* and *BR*.

## Chapter 11

### Conclusions and future work

#### 11.1 Conclusions

This study aimed at developing an alternative method and system for measuring the drapeability of nonwovens engineered for apparel use in order to give better capability for drape understanding and analysis.

➤ A comprehensive literature review about fabric objective measurement focused on fabric drape measurement methods and factors affecting drape was carried out. This review showed that extensive research concerned with fabric drape has been carried out by many researchers since 1930. Most of these studies were concerned with conventional fabrics (woven and knitted). There was no appropriate attention paid to nonwoven fabric drape and use as shell fabrics, relative to the progress in nonwovens that have been engineered in the last decade for apparel use.

Moreover, the design and form of the supporting bodies employed in commonly used fabric drape measurement systems are not related to the human body shape which may render them less effective for carrying out reliable and accurate drape profile assessment and analysis. The alternative methods used in this study overcomes this problem.

➤ In this study a range of conventional and nonwoven fabrics were tested. Although nonwoven garment drape is the focus of this study, conventional fabrics (knitted and woven) suitable for making women's dress were involved to support the resulting data in terms of subjective and objective comparisons/studies, improve the calculated statistical values and provide clear information about the nonwovens' drape. Nonwoven, woven and knitted fabrics already used for apparel making were included. A group of conventional fabrics were used including two knitted fabrics and five woven fabrics. Their weights were suitable for making women's dress. Five hydroentangled nonwoven (EVOLON) fabrics of different weights, ranging from 80-170 g/m<sup>2</sup>, were used.

➤ The physical and low stress mechanical properties of the tested fabrics range were used for fabric identification (i.e. bending length (*BL*) in mm, bending rigidity (*BR*) in  $\mu\text{Nm}$ , bending modulus (*BM*) in  $\text{Kg/cm}^2$ , Formability (*FR*) in  $\text{mm}^2$ , Extensibility (*E*) at 5, 20, 100 gf/cm, Shear rigidity (*G*) in  $\text{N/m}$ , Thickness (*T*) at 2 and 100  $\text{gf/cm}^2$  and Surface thickness (*ST*)).

It was found that the most important parameters affecting drape were bending length and shear rigidity. It was found that the tested nonwoven fabrics have high bending length which was sometimes similar to conventional fabrics. This suggests that these nonwovens would be able to drape in a similar manner to some conventional fabrics. The nonwoven fabrics were found to have almost infinite values of shear rigidity which was the case in some conventional fabrics tested. These findings suggest that nonwoven fabrics would have less drapeability than some conventional fabrics but would drape like others. The nonwoven fabric bending rigidity is also similar to conventional fabrics tested. The bending modulus was similar for all the fabrics except one fabric (N1 unsoftened 100 g/m<sup>2</sup> with a very papery handle). The nonwoven fabric extensibility was far less than conventional fabrics in E100. However the range of their thickness is similar to the conventional fabrics and sometimes less than knitted fabrics.

These findings show that there were similarities in the mechanical behaviour of both nonwovens and some conventional fabrics (already used in apparel making).

➤ During fabric range identification, a comparative study was carried out between four different methods of *BL* measurement (Shirley, FAST 2, Heart loop and bending loop). These were found strongly correlated with each other and there were significant agreements between them. The Heart loop test was the most reproducible method. Shirley was the highest in sensitivity and discrimination ability. The stiffness level of the measured fabrics does not affect the stability between methods. The Heart loop and bending loop tests which were correlated strongly and agreed with the cantilever methods would be suggested to do the whole range of fabrics.

A further comparative study between bending loop and Heart loop was carried out aimed at introducing a method which would be able to measure a range of fabrics including materials with bending length values more than the maximum of the cantilever methods (high stiffness) and lower than their minimum (low stiffness/limp). It was found that both methods could be used efficiently to measure a range of fabrics involving different stiffness degrees between limp ( $BL = 0.5$  cm) and very stiff fabrics ( $BL = 5$  cm). The differences are statistically insignificant. But the selection of one of them would be based on other parameters for instance, relative precision, relative sensitivity and discrimination ability.

Including very limp and stiff fabrics increased the two methods' correlation, relative sensitivity and discrimination ability, however, their reproducibility decreased. The bending loop test had higher sensitivity than the Heart loop test. Therefore, the Heart loop test was selected to carry out further

measurements as mentioned above based on its better precision and discrimination ability than the bending loop test.

➤ The drape coefficient (conventional drape parameter) of the tested fabrics was measured using manual and digital (image analysis) and was found highly correlated. The number of nodes was correlated with the drape coefficient negatively and strongly. Some nonwoven fabrics produced the highest DC, and the least and largest node numbers and sizes respectively (if any existed) compared with some conventional fabrics. The nonwoven fabrics vastly differ from some conventional fabrics with regard to fabric drapeability but are similar to others. The knitted fabrics had the highest drapeability.

➤ An alternative drape measurement system was developed consisting of a suspended mannequin to hang the garment being measured and a digital camera to capture a photo for the garment hung from below. A graphical user interface was developed to calculate drape values of flat fabrics on drapemeter and garments on mannequin images to assess drapeability using an image analysis technique. It was found that drape shape parameters of garments could not be predicted using corresponding fabric drape shape parameters. This means that textile engineers and scientists working on drape measurement and simulation have to measure drape shape properties for garments on a mannequin rather than flat fabric supported on a circular disc.

Strong correlations were found between DC and other drape values including Area, Circularity and Peak number. Any of these parameters could be used as alternative parameters for DC.

➤ Subjective assessment of fabric and garment drape were carried out. The drape ability was assessed using physical materials and images for both fabrics and garments. Assessment of fabric drape ability using either material/technique was found to have high agreement between judges. Therefore, it was concluded that using either method is useful for fabric drape ability assessment subjectively. The drape ability of some nonwoven fabrics evaluated was similar to other conventional fabrics but better than others.

➤ With regard to drape preference, although there was low agreement between judges for drape preference, if average rank values resulting from drape preference were to be used, some nonwovens were grouped with

some conventional fabrics (insignificant differences between them) or more preferred than them.

➤ Fabric properties affecting drape were investigated in the form of direct quantitative evaluation methods. Regression analysis was applied to develop new equations predicting garment and fabric rank scores using proposed drape values and FAST properties.

The mechanical properties employed in predicting rank scores were generally *E100*, *BL* and *BR*. The drape values used in predicting drape rank scores were: Circularity, Area, Peak no, *WL MAX*, *WL MIN*, *WHCV*, *WAA*, *WAMAX*, *WAMIN*, *AM/WH*, *D/O*, Fourier.

The usefulness of this research is that it challenges the use of flat fabric measurements of drape properties. It is suggested that as fabrics in garments are never draped in this manner then we need to seek a more suitable measurement system. An alternative has been suggested, evaluated and though more studies are required, a considerable degree of success has been achieved.

## **11.2 Limitations of the current research**

Any research study has to have limitations due to the time available, the resources available and the level of the extant body of knowledge at the beginning of the study.

- It seemed to the researcher that the existing research in the field was exhaustive and of a very high level. However, the various studies had taken so many varied approaches that it was difficult to identify the most appropriate stage of entry.
- It is accepted that a wider range of garment types could have been used and this would have helped to identify the limitations of the proposed alternative method.
- As always, a larger and wider number of subjective assessment judges would have been helpful.

## **11.3 Future work**

Further studies are recommended and required into measurement of fabric drapeability:

- As recently a variety of nonwoven fabrics have become available in the fabric market, a wider range of fabrics including different commercial nonwovens, which would give acceptable drapeability for garment use, could be investigated.

- Investigating the reliability of the proposed drape parameters in this study by fabric simulation is recommended.
- Development of alternative drape parameters using image analysis methods providing representative and reliable parameters for apparel making is required.
- Studying durability and comfort of nonwoven garments.
- Investigating the effect of laundry and softening treatment on nonwoven drape.



## List of References

- ABBOTT, N. J. 1951. The measurement of stiffness in textile fabrics. *Textile Research Journal*,**21**(6), pp.435-441.
- AGARWAL, G., L. KOEHL and A. PERWUELZ. 2011. Interaction of wash-ageing and use of fabric softener for drapeability of knitted fabrics. *Textile Research Journal*,**81**(11), pp.1100-1112.
- AL-GAADI, B., F. GÖKTEPE and M. HALÁSZ. 2011. A new method in fabric drape measurement and analysis of the drape formation process. *Textile Research Journal*,**82**(5), pp.1-11.
- AMIRBAYAT, J. and J. W. S. HEARLE. 1986a. The complex buckling of flexible sheet materials. Part I: theoretical approach. *International Journal of Mechanical Sciences*,**28**(6), pp.339-358.
- AMIRBAYAT, J. and J. W. S. HEARLE. 1986b. The complex buckling of flexible sheet materials. Part II: experimental study of three-fold buckling. *International Journal of Mechanical Sciences*,**28**(6), pp.359-370.
- AMIRBAYAT, J. and J. W. S. HEARLE. 1989a. The anatomy of buckling of textile fabrics: drape and conformability. *Journal of the Textile Institute*,**80**(1), pp.51-70.
- AMIRBAYAT, J. and J. W. S. HEARLE. 1989b. A new method in fabric drape measurement and analysis of drape formation process. *Journal of the Textile Institute*,**80**(1), pp.51 - 70.
- ANDERSON, K. 2012. Nonwoven fabrics in fashion apparel. *Techexchange.com* [online]. [Accessed 04/08/2012]. Available from: <http://www.techexchange.com/library/Nonwoven%20Fabrics%20in%20OFashion%20Apparel.pdf>.
- BACKER, S. 1948. The relationship between the structural geometry of a textile fabric and its physical properties. *Textile Research Journal*,**18**(11), pp.650-658.
- BACKER, S. and D. R. PETERSON. 1960. Some principles of nonwoven fabrics1. *Textile Research Journal*,**30**(9), pp.704-711.
- BEHERA, B. K. and R. MISHRA. 2006. Objective measurement of fabric appearance using digital image processing. *Journal of the Textile Institute*,**97**(2), pp.147-153.
- BEHERA, B. K. and A. PANGADIYA. 2003. Drape measurement by digital image processing. *Textile Asia*,**34**(11), pp.45-50.
- BEHERA, B. K. and A. K. PATTANAYAK. 2008. Measurement and modeling of drape using digital image processing. *Indian journal of fibre and textile research*,**33**(3), pp.230-238.
- BENDALI, F., J. KOKO and A. QUILLIOT. 1999. The draping of fabrics over arbitrary surfaces: an augmented-lagrangian method. *Journal of the Textile Institute*,**90**(2), pp.177-186.
- BISHOP, D. P. 1996. Fabrics: sensory and mechanical properties. *Textile Progress*,**26**(3), pp.1-62.
- BLACKLEY, D. C. 1997. *Polymer latices: applications of Latices*. London: Chapman and Hall.

- BONACICH, E., L. CHENG, N. CHINCHILA and P. ONG. 1994. *Global production: the apparel industry in the Pacific Rim*. Philadelphia: Temple University Press.
- BOOTH, J. 1968. *Principles of textile testing : an introduction to physical methods of testing textile fibres, yarns and fabrics*. 3rd ed. London: Heywood Books.
- BRAND, R. H. 1964. Measurement of fabric aesthetics: analysis of aesthetic components *Textile Research Journal*,**34**(9), pp.791-804.
- BREEN, D. E., D. H. HOUSE and M. J. WOZNY. 1994. A particle-based model for simulating the draping behavior of woven cloth. *Textile Research Journal*,**64**(11), pp.663-685.
- BRITISH STANDARD INSTITUTION. 1990. *Method for determination of bending length and flexural rigidity of fabrics*. London: BSI.
- BRITISH STANDARDS INSTITUTION. 1973. *Method for the assessment of drape fabrics*. London: BSI.
- BRITISH STANDARDS INSTITUTION. 1991. *Stitches and seams. Classification and terminology of stitch types*. London: BSI.
- BRITISH STANDARDS INSTITUTION. 1998. *Textiles - Test methods for nonwovens. Part 9: Determination of drape coefficient*. London: BSI.
- BRITISH STANDARDS INSTITUTION. 2005. *Textiles - Textiles - Woven fabrics - Determination of mass per unit length and mass per unit area*. London: BSI.
- BRITISH STANDARDS INSTITUTION. 2008. *Textiles. Test methods for nonwovens. . Determination of drapability including drape coefficient*. London: BSI.
- BURESH, F. M. 1962. *Nonwoven fabrics*. New York: Reinhold Pub Corp.
- CASSIDY, C. 2002. *An investigation of the mechanical and surface properties of weft knitted fabrics and their influence on sewability during garment assembly*. Ph.D. thesis, De Montfort University.
- CASSIDY, T., C. CASSIDY, S. CASSIE and M. ARKISON. 1991. The stiffness of knitted fabrics: a new approach to the measurement of bending. Part 1: development. *International Journal of Clothing Science and Technology*,**3**(5), pp.14-19.
- CHATTOPADHYAY, R. 2008. Design of apparel fabrics: role of fibre, yarn and fabric parameters on its functional attributes. *Journal of Textile Engineering*,**54**(6), pp.179-190.
- CHAUDHARI, S., A. MANDOT, P. MILIN and M. KARANSINGH. 2012. A review on nonwoven fabrics used in apparel *Fibre2fashion.com* [online]. [Accessed 02/08/2012]. Available from: <http://www.fibre2fashion.com/industry-article/16/1584/a-review-on-nonwoven-fabrics-used-in-apparel1.asp>.
- CHEN, B. and M. GOVINDARAJ. 1995. A physically based model of fabric drape using flexible shell theory. *Textile Research Journal*,**65**(6), pp.324-330.
- CHEN, S. F., J. L. HU and J. G. TENG. 2001. A finite-volume method for contact drape simulation of woven fabrics and garments. *Finite Elements in Analysis and Design*,**37**(6-7), pp.513-531.
- CHU, C. C., C. L. CUMMINGS and N. A. TEIXEIRA. 1950. Mechanics of elastic performance of textile materials. Part V: a study of the factors

- affecting the drape of fabrics -the development of a drape meter. *Textile Research Journal*,**20**(8), pp.539-548.
- CHU, C. C., M. M. PLATT and W. J. HAMBURGER. 1960. Investigation of the factors affecting the drapeability of fabrics. *Textile Research Journal*,**30**(1), pp.66-67.
- CHUNG, S. P., J. L. HU and M. T. LO. 1997. The relationship between fabric drape and seam parameters. In: *The 78th world conference of the textile institute in association with the 5th textile symposium of Seve and Sepve*, Thessalonika. The Institute, pp.175-187.
- glbtq: An Encyclopedia of Gay, Lesbian, Bisexual, Transgender, and Queer Culture*. 2002. s.v. Halston (Roy Halston Frowick).
- COLLIER, B. J. 1991. Measurement of fabric drape and its relation to fabric mechanical properties and subjective evaluation. *Clothing and Textiles Research Journal*,**10**(1), pp.46-52.
- COLLIER, B. J. and J. R. COLLIER. 1990. CAD/CAM in the textile and apparel industry. *Clothing and Textiles Research Journal*,**8**(3), pp.7-13.
- COLLIER, B. J., V. A. PAULINS and J. R. COLLIER. 1989. Effects of interfacing type on shear and drape behavior of apparel fabrics. *Clothing and Textiles Research Journal*,**7**(3), pp.51-56.
- COLLIER, J. R., B. J. COLLIER, G. O'TOOLE and S. M. SARGAND. 1991. Drape prediction by means of finite-element analysis. *Journal of the Textile Institute*,**82**(1), pp.96-107.
- CORBMAN, B. P. 1983. *Textiles: fiber to fabric*. 6th ed. New York: McGraw-Hill.
- COSTA, L. D. F. and R. M. C. JR. 2000. *Shape analysis and classification: theory and practice*. Boca Raton: CRC Press.
- CSIRO. 1991. *Fabric assurance by simple testing: instruction manual*. Cisro, Australia.
- CUI, F. F., X. ZHANG and L. S. WANG. 2010. Study of the relationship between jacket - business wear fitness and fabric drape. In: *The 3rd International Symposium of Textile Bioengineering and Informatics*, pp.1299-1306.
- CUSICK, G. E. 1962. *A study of fabric drape*. PhD thesis, Univeristy of Manchester.
- CUSICK, G. E. 1965. The dependence of fabric drape on bending and shear stiffness. *Journal of the Textile Institute Transactions*,**56**(11), pp.596-606.
- CUSICK, G. E. 1968. The measurement of fabric drape. *Journal of the Textile Institute*,**59**(6), pp.253-260.
- CUSICK, G. E., J. W. S. HEARLE, R. I. C. MICHIE, R. H. PETERS and P. J. STEVENSON. 1963. Physical properties of some commercial non-woven fabrics. *Journal of the Textile Institute Proceedings*,**54**(1), pp.52-74.
- DHANGE, V. K., L. WEBSTER and A. GOVEKAR. 2012. Nonwovens in fashion apparel applications. *International Journal of Fiber and Textile Research*,**2**(2), pp.12-20.

- DHINGRA, R. C. and R. POSTLE. 1980. Some aspects of the tailorability of woven and knitted outerwear fabrics. *Clothing Research Journal*,8(1), pp.59-74.
- DOWDY, S., S. WEARDEN and D. CHILKO. 2011. *Statistics for Research*. Wiley series in probability and mathematical statistics. New york: Wiley.
- DUTTON, K. C. 2009. *Consumer acceptance of nonwoven fabrics for apparel and accessory end-uses*. PhD thesis, North Carolina State University.
- EDANA. 1988. EDANA Nordic nonwovens symposium. *In: Nordic nonwovens symposium*, Stockholm. European disposables and nonwovens association.
- EDANA. 2012a. *Clothing, footwear, baggage* [online]. [Accessed 12/05/2009].
- EDANA. 2012b. *Web formation* [online]. [Accessed 01/01/2011]. Available from:  
<http://www.edana.org/Content/Default.asp?PageID=41#spunlaid>.
- EDISON INVESTMENT RESEARCH LIMITED. 2010. *Nonwovens*. Edison Investment Research Limited, London.
- ELDER, H. M., S. FISHER, K. ARMSTRONG and G. HUTCHINSON. 1984. Fabric stiffness, handle, and flexion. *Journal of the Textile Institute*,75(2), pp.99-106.
- ELSASSER, V. H. 2005. *Textiles: concepts and principles*. 2nd ed. New York: Fairchild.
- EVOLON. 2012. *Environment* [online]. [Accessed 03/04/2011]. Available from: <http://www.evolon.com/environment,10435,en/>.
- FABRICS.NET. 2011. *The Indian head connection - skinner and sons* [online]. [Accessed 04/08/2012]. Available from: <http://info.fabrics.net/the-indian-head-connection-skinner-sons/>.
- FAN, J. 2004. *Clothing appearance and fit: science and technology*. Cambridge: Woodhead Publishing in association with The Textile Institute.
- FARAJIKHAH, S., K. MADANIPOUR, S. SAHARKHIZ and M. LATIFI. 1986. *3D reconstruction of fabric drape using shadow moiré topography*. [Accessed 1/12/2011]. Available from: [https://docs.google.com/viewer?a=v&q=cache:AtUODSth75MJ:cisedu.us/storage/hpcs/2011/syamak1986\\_at\\_gmail.com-2011.02.03-03.42.03-Article.pdf+3D+Reconstruction+of+Fabric+Drape&hl=en&pid=bl&srcid=ADGEEsiJsuOyzMaRcpTS5MYIu0ISWst4jdgFQ3SnOZuVRtTfp9Lv9k8SEiaLouw3AADW\\_JvNZdpUTedtg4f-afHZzhvWMKweEHMi9T1RUun6wDVG-CkgL9INWqgGdk\\_A1X3\\_jzf\\_4dl&sig=AHIEtbRrkVLes8AsoZCiA2fEF-avx1fBsA](https://docs.google.com/viewer?a=v&q=cache:AtUODSth75MJ:cisedu.us/storage/hpcs/2011/syamak1986_at_gmail.com-2011.02.03-03.42.03-Article.pdf+3D+Reconstruction+of+Fabric+Drape&hl=en&pid=bl&srcid=ADGEEsiJsuOyzMaRcpTS5MYIu0ISWst4jdgFQ3SnOZuVRtTfp9Lv9k8SEiaLouw3AADW_JvNZdpUTedtg4f-afHZzhvWMKweEHMi9T1RUun6wDVG-CkgL9INWqgGdk_A1X3_jzf_4dl&sig=AHIEtbRrkVLes8AsoZCiA2fEF-avx1fBsA).
- FASHION AND STYLE. 2012. *What is a shift dress how do I wear one?* [online]. [Accessed 1/8/2009]. Available from: <http://fashionoverstyle.net/2007/11/26/what-is-a-shift-dress-how-do-i-wear-one/>.

- FIDM MUSEUM. 2009. *Would you believe it's paper?* [online]. [Accessed 01/03/2011]. Available from: <http://blog.fidmmuseum.org/>.
- FISCHER, P., S. KRZYWINSKI, H. RODEL, A. SCHENK and V. ULBRICHT. 1999. Simulating the drape behavior of fabrics1. *Textile Research Journal*,**69**(5), pp.331-334.
- FLOYD, K. L. 1975. Factors limiting the application of nonwovens in the apparel field. *In: Progress in nonwovens*, Manchester. Shirley Institute pp.39-52.
- FREESTON, W. D. and M. M. PLATT. 1965. Mechanics of elastic performance of textile materials. *Textile Research Journal*,**35**(1), pp.48-57.
- FRIEDMAN, M. 1937. The use of ranks to avoid the assumption of normality implicit in the analysis of variance. *Journal of the American Statistical Association (American Statistical Association)*,**32**(200), pp.675–701.
- FRYDRYCH, I., G. DZIWORSKA and A. CIESLINSKA. 2000. Mechanical fabric properties influencing the drape and handle. *International Journal of Clothing Science and Technology*,**12**(3), pp.171-183.
- FRYDRYCH, I., G. DZIWORSKA and M. MATUSIAK. 2003. Influence of the kind of fabric finishing on selected aesthetic and utility properties. *Fibres and Textiles in Eastern Europe*,**11**(3), pp.31-37.
- GAN, L., N. G. LY and G. P. STEVEN. 1995. A study of fabric deformation using nonlinear finite elements. *Textile Research Journal*,**65**(11), pp.660-668.
- GAUCHER, M. L., M. W. KING and B. JOHNSTON. 1983. Predicting the drape coefficient of knitted fabrics. *Textile Research Journal*,**53**(5), pp.297-303.
- GIDER, A. 2004. *An online fabric database to link fabric drape and end-use properties*. Master of Science thesis, Louisiana State University
- GREENWALD, E. F. 1986. Home furnishing markets for nonwovens. *Journal of Industrial Textiles*,**15**(3), pp.205-214.
- GROSBURG, P. 1966. The mechanical properties of woven fabrics. Part II: the bending of woven fabrics. *Textile Research Journal*,**36**(3), pp.205-211.
- GROVER, G., M. A. SULTAN and S. M. SPIVAK. 1993. A screening technique for fabric handle. *Journal of the Textile Institute*,**84**(3), pp.486-494.
- HAIDEKKER, M. A. 2011. *Advanced biomedical image analysis*. Chichester: Wiley.
- HAMMAD, M. 2010. *Nonwoven fabric* [online]. [Accessed 04/08/2012]. Available from: <http://sst.umt.edu.pk/newsite/courses/Spring2010/TX-224/3-%20Non%20Woven%20Web%20formation.pdf>.
- HARDAKER, C. H. M. and G. J. W. FOZZARD. 1998. Towards the virtual garment: three-dimensional computer environments for garment design. *International Journal of Clothing Science and Technology*,**10**(2), pp.114-127.
- HEARLE, J. W. S. 1969. *Structural mechanics of fibers, yarns, and fabrics*. New York: Wiley Interscience.
- HEARLE, J. W. S. and J. AMIRBAYAT. 1986. Analysis of drape by means of dimensionless groups. *Textile Research Journal*,**56**(12), pp.727-733.

- HEARLE, J. W. S. and J. AMIRBAYAT. 1988. The design of a multipurpose fabric tester. *Journal of the Textile Institute*,**79**(4), pp.588-597.
- HEARLE, J. W. S., R. I. C. MICHIE and P. J. STEVENSON. 1964. Nonwoven fabric studies. Part V: the dependence of fabric stiffness and drape on the properties of the constituent fiber and binder. *Textile Research Journal*,**34**(4), pp.275-282.
- HEGDE, R. R., G. S. BHAT and R. A. CAMPBELL. 2008. Thermal bonding of polypropylene films and fibers. *Journal of Applied Polymer Science*,**110**(5), pp.3047-3058.
- HOLLIDAY, T. M. 1993. *Nonwovens : theory, process, performance, and testing*. Atlanta: TAPPI Press.
- HOLLIES, N. R. S. 1989. Visual and tactile perceptions of textile quality. *Journal of the Textile Institute*,**80**(1), pp.1-18.
- HOWORTH, W. S. and P. H. OLIVER. 1958. The application of multiple factor analysis to the assessment of fabric handle. *Journal of the Textile Institute Transactions*,**49**(11), pp.T540-T553.
- HU, J. 2004. *Structure and mechanics of woven fabrics*. Abingdon: Woodhead Publishing.
- HU, J. and Y. F. CHAN. 1998. Effect of fabric mechanical properties on drape. *Textile Research Journal*,**68**(1), pp.57-64.
- HU, J., S. CHUNG and M. T. LO. 1997. Effect of seams on fabric drape. *International Journal of Clothing Science and Technology*,**9**(3), pp.220-227.
- HU, J. L. 1997. A review on the study of fabric drape. Part 1: evaluation methods and emperical studies. *Research journal of textile and apparel*,**1**, pp.126-136.
- HU, J. L., S. F. CHEN and J. G. TENG. 2000. Numerical drape behavior of circular fabric sheets over circular pedestals. *Textile Research Journal*,**70**(7), pp.593-603.
- HU, J. L. and S. P. CHUNG. 1998. Drape behavior of woven fabrics with seams. *Textile Research Journal*,**68**(12), pp.913-919.
- HUTTEN, I. M. 2007. *Handbook of nonwoven filter media*. London: Elsevier.
- HWAN SUL, I., T. JIN KANG, S. MIN KIM and Y. S. CHI. 2006. Simulation of Cusick drapemeter using particle-based modeling: stability analysis of explicit integration methods. *Textile Research Journal*,**76**(9), pp.712-719.
- HYNEK, W. J. and G. WINSTON. 1953. A comparative study of the Tinius Olsen and Peirce stiffness testers. *Textile Research Journal*,**23**(10), pp.743-748.
- INDA. 1995. *The needlepunch primer*. Cary: INDA.
- INDA. 2012a. *About Nonwovens* [online]. [Accessed 01/01/2011]. Available from: [www.inda.org/](http://www.inda.org/).
- INDA. 2012b. *INDA releases global spunlace report* [online]. [Accessed]. Available from: [http://www.nonwovens-industry.com/issues/2012-05/view\\_breaking-news/inda-releases-global-spunlace-report/](http://www.nonwovens-industry.com/issues/2012-05/view_breaking-news/inda-releases-global-spunlace-report/).
- JEDDA, H., A. GHITH and F. SAKLI. 2007. Prediction of fabric drape using the FAST system. *Journal of the Textile Institute*,**98**(3), pp.219-225.

- JEONG, Y. J. 1998. A study of fabric drape behaviour with image analysis. Part I: measurement, characterisation, and instability. *Journal of the Textile Institute*,**89**(1), pp.59 - 69.
- JEONG, Y. J. and D. G. PHILLIPS. 1998. A study of fabric drape behaviour with image analysis. Part II: The effects of fabric structure and mechanical properties on fabric drape. *Journal of the Textile Institute*,**89**(1), pp.70-79.
- JEVŠNIK, S. and J. GERŠAK. 2004. Modelling the fused panel for a numerical simulation of drape. *Fibres and Textiles in Eastern Europe*,**12**(1), pp.47-52.
- JEVŠNIK, S. and D. ŽUNIČ-LOJEN. 2007. Drape behaviour of seamed fabrics. *Fibers and Polymers*,**8**(5), pp.550-557.
- JEVŠNIK S. and GERŠAK J. 2004. Modelling the Fused Panel for a Numerical Simulation of Drape. *FIBRES & TEXTILES in Eastern Europe* [online]. **12**(1), [Accessed 1/12/2011], pp.47-52. Available from: <http://www.fibtex.lodz.pl/archive.htm>.
- JOHNSON, N. A. G., E. J. WOOD, P. E. INGHAM, S. J. MCNEIL and I. D. MCFARLANE. 2003. Wool as a technical fibre. *Journal of the Textile Institute*,**94**(3-4), pp.26-41.
- JOWETT, P. D. 1975. The production of apparel fabrics by needle-punching. *In: The 5th International Wool Textile Research Conference*, Aachen. Wool research centre.
- KALYANARAMAN, A. R. and A. SIVARAMAKRISHNAN. 1984. An electronic fabric stiffness meter - performance evaluation with the known instruments. *Textile Research Journal*,**54**(7), pp.479-484.
- KENDALL, M. G. and B. B. SMITH. 1939. The Problem of m Rankings. *The Annals of Mathematical Statistics*,**10**(3), pp.275–287.
- KENKARE, N., T. A. M. LAMAR, P. PANDURANGAN and J. EISCHEN. 2008. Enhancing accuracy of drape simulation. Part I: investigation of drape variability via 3D scanning. *Journal of the Textile Institute*,**99**(3), pp.211-218.
- KENKARE, N. and T. MAY-PLUMLEE. 2005. Fabric drape measurement: a modified method using digital image processing. *Journal of Textile and Apparel, Technology and Management*,**4**(3 spring ), pp.1-8.
- KENKARE, N. S. 2005. *Three dimensional modeling for garment drape*. Ph.D. thesis, North carolina state.
- KESSELAER, N. 2006. Fashion show helps nonwovens hit the runway. *Tredegar Film Products* [online]. [Accessed 04/08/2012]. Available from: <http://www.tredegarfilms.com/News/Releases/FashionShow.pdf>.
- KIM, J. O. and B. L. SLATEN. 1999. Objective evaluation of fabric hand. Part I: relationships of fabric hand by the extraction method and related physical and surface properties. *Textile Research Journal*,**69**(1), pp.59-67.
- KOENIG, S. K. and S. J. KADOLPH. 1983. Comparison of performance characteristics of seven fusible interfacings. *Textile Research Journal*,**53**(6), pp.341-346.
- KOKAS-PALICSKA, L., I. SZÜCS and Z. BORKA. 2008. Characterisation of fabric drape using spectral functions *Journal of Applied Sciences*,**5**(3), pp.75-85.

- KRCMA, R. 1971. *Manual of nonwovens*. Manchester: Textile trade press.
- LAM, A., A. RAHEJA and M. GOVINDARAJ. 2004. Neural network models for fabric drape prediction. *In: IEEE International Symposium on Neural networks*, Budapest. IEEE, pp.2925-2929.
- LAMB, G. E. R. and P. A. COSTANZA. 1975. Properties and potential applications of nonwoven crepe fabrics. *Textile Research Journal*,**45**(10), pp.722-728.
- LEAF, G. A. V. 1987. *Practical statistics for the textile industry. Part 2*. Manchester: Textile Institute.
- LEGENDRE, P. 2005. Species associations: the Kendall coefficient of concordance revisited. *Journal of Agricultural, Biological and Environmental Statistics*,**10**(2), pp. 226–245.
- LIN, J. Y., P. N. WANG and T. W. SHYR. 2008. Comparing and modeling the dynamic drape of four natural-fiber fabrics. *Textile Research Journal*,**78**(10), pp.911-921.
- LO, W. M., J. L. HU and L. K. LI. 2002. Modeling a fabric drape profile. *Textile Research Journal*,**72**(5), pp.454-463.
- LYUKSHINOVA, I. V., A. V. KURDENKOVA and Y. S. SHUSTOV. 2008. Prediction of the air permeability of thermobonded nonwovens. *Fibre Chemistry*,**40**(2), pp.136-139.
- MAGNENAT-THALMANN, N. and P. VOLINO. 2005. From early draping to haute couture models: 20 years of research. *Visual Computer*,**21**(8-10), pp.506-519.
- MAHAR, T. J., P. WHEELWRIGHT, R. C. DHINGRA and R. POSTLE. 1990. Measuring and interpreting fabric low stress mechanical and surface properties. *Textile Research Journal*,**60**(1), pp.7-17.
- MATHEWS, P. 2010. *Sample size calculations: practical methods for engineers and scientists*. Fairport Harbor: Paul Mathews and Baily Inc.
- MATSUDAIRA, M., Y. TAN and Y. KONDO. 1993. The effect of fibre cross-sectional shape on fabric mechanical properties and handle. *Journal of the Textile Institute*,**84**(3), pp.376-386.
- MATSUDAIRA, M. and M. YANG. 2000. Some features of the static and dynamic drape behaviour of polyester-fibre shingosen fabrics. *Journal of the Textile Institute*,**91**(4), pp.600-615.
- MATSUDAIRA, M. and M. YANG. 2003a. Changes of static- and dynamic-drape coefficients of polyester-fiber woven fabrics by weight reduction in sodium hydroxide solution. *Journal of Textile Engineering*,**49**(2), pp.27-32.
- MATSUDAIRA, M. and M. YANG. 2003b. Features of conventional static and new dynamic drape coefficients of woven silk fabrics. *Textile Research Journal*,**73**(3), pp.250-255.
- MATSUDAIRA, M., M. YANG, T. KINARI and S. SHINTAKU. 2002. Polyester "Shingosen" fabrics characterized by dynamic drape coefficient with swinging motion. *Textile Research Journal*,**72**(5), pp.410-416.
- MATSUDAIRA, M., M. Z. YANG, T. KINARI and S. SHINTAKU. 2003. Changes in the static and dynamic drape coefficients of polyester



- fabrics through the finishing stages. *Textile Research Journal*,**73**(1), pp.59-63.
- MATSUDAIRAA, M., S. YAMAZAKI and Y. HAYASHI. 2008. Changes in dynamic drapability of polyester fabrics with weave density, yarn twist and yarn count obtained by regression equations. *Indian journal of fibre and textile research*,**33**(3), pp.223-229.
- MCCARTNEY, J., B. K. HINDS, B. L. SEOW and D. GONG. 2000. Dedicated 3D CAD for garment modelling. *Journal of Materials Processing Technology*,**107**(1-3), pp.31-36.
- MCINTYRE, K. 2009. Awaiting Apparel despite a lot of interest, nonwovens have not yet made inroads in clothing. *Nonwovens Industry*,**12**.
- MICHIE, R. I. C. and P. J. STEVENSON. 1966. Nonwoven fabric studies. Part VII: the effect of stretching on the mechanical properties of nonwoven fabrics. *Textile Research Journal*,**36**(6), pp.494-501.
- MILLER, E. 1992. *Textiles:properties behaviour in clothing use*. London: B. T. Batsford Ltd.
- MIZUTANI, C., T. AMANO and Y. SAKAGUCHI. 2005. A new apparatus for the study of fabric drape. *Textile Research Journal*,**75**(1), pp.81-87.
- MOORE, C. L. 1992. Factors that affect undesirable garment drape. *Journal of Home Economics*,**84**(3), pp.31-3.
- MOORE, C. L., L. M. GUREL and M. LENTNER. 1995. Effects of fabric skewness on the drape of four-gore skirts. *Clothing and Textiles Research Journal*,**13**(2), pp.131-138.
- MORI, T. and D. W. LLOYD. 1994. Measuring the twisting rigidity of woven fabrics. *Textile Research Journal*,**64**(7), pp.397-405.
- MOROOKA, H. and M. NIWA. 1976. Relation between drape coefficients and mechanical properties of fabrics. *The Journal of the Textile Machinery Society of Japan*,**22**(3), pp.67-73.
- MPH DESIGN. 2012. *History of the paper dress* [online]. [Accessed 02/08/2012]. Available from: <http://www.mphdesign.net/page11.html>.
- NEWTON, A. and J. E. FORD. 1973. The production and properties of nonwoven fabrics. *Textile Progress*,**5**(3), pp.1-86.
- NG, S. F., C. L. HUI and F. Y. TAM. 2002. Analysis of fabric drape and garment drape. *Research journal of textile and apparel*,**6**(2), pp.65-74.
- NGOC, N. T. T. and H. N. ANH. 2008. Investigating on fabric and skirt drape in clothing construction. *World Journal Of Engineering*,**7**(supplement 1), pp.1-8.
- OKUR, A. and T. GIHAN. 1993. Prediction of fabric drape coefficients from FAST data. *Textile Asia*,**33**(7), pp.28-31.
- ÖNDER, E., F. KALAO and B. ÖZIPEK. 2003. Influence of varying structural parameters on the properties of 50/50 wool/polyester blended fabrics. *Textile Research Journal*,**73**(10), pp.854-860.
- ORZADA, B. 2006. Blank canvas: nonwoven fashion apparel and accessories could become an emerging market. *Nonwovens Industry*,**12**.
- ORZADA, B. T., M. A. MOORE and B. J. COLLIER. 1997. Grain alignment: effects on fabric and garment drape. *International Journal of Clothing Science and Technology*,**9**(4), pp.272-284.

- PAN, N. 2007. Quantification and evaluation of human tactile sense towards fabrics. *The International Journal of Design and Nature and Ecodynamics*,**1**(1), pp.48-60.
- PANDURANGAN, P. 2003. *Mechanics of fabric drape*. Master of Science thesis, North Carolina State University.
- PANDURANGAN, P., J. EISCHEN, N. KENKARE and T. A. M. LAMAR. 2008. Enhancing accuracy of drape simulation. Part II: optimized drape simulation using industry-specific software. *Journal of the Textile Institute*,**99**(3), pp.219-226.
- PATEL, S. V. and S. B. WARNER. 1994. Modelling the bending stiffness of point bonded nonwoven fabrics. *Textile Research Journal*,**64**(9), pp.507-513.
- PEIRCE, F. T. 1930. The handle of cloth as a measurable quantity. *Journal of the Textile Institute Transactions*,**21**(9), pp.T377-T416.
- PGI GROUP. 2012. *APEX fabrics* [online]. [Accessed 05/04/2011]. Available from: <http://www.pgi-industrial-europe.com/en/apex-fabrics>.
- POSTLE, J. and R. POSTLE. 2000. Fabric drape. *Textile Asia*,**31**(1), pp.30-32.
- POSTLE, J. R. and R. POSTLE. 1993. Fabric drape based on objective measurement of fabric bending length. *Textile Asia*,**24**(2), pp.63-66.
- POSTLE, J. R. and R. POSTLE. 1999. The dynamics of fabric drape. *Textile Research Journal*,**69**(9), pp.623-629.
- POTLURI, P., S. SHARMA and R. RAMGULAM. 2001. Comprehensive drape modelling for moulding 3D textile preforms. *Composites Part a- Applied Science and Manufacturing*,**32**(10), pp.1415-1424.
- POURDEYHIMI, B. 2004. Nonwovens and traditional textile Know-How. *TEXTILE WORLD*,**154**(8), pp.42-45.
- PURDY, A. T. 1980. *Needle-punching*. Manchester: Textile Institute.
- PURDY, A. T. 1983. Developments in non-woven fabrics. *Textile Progress*,**12**(4), pp.1-86.
- PURDY, A. T. 1985. *Non-woven bonded fabrics*. Manchester: Textile Institute.
- QUIRK, M. M., T. L. MARTIN and M. T. JONES. 2009. Inclusion of fabric properties in the e-textile design process. *In: 13th IEEE International symposium on wearable computers*, Linz. IEEE, pp.37-40.
- RAMAKRISHNAN, G., D. BHAARATHI and S. MUKHOPADHYAY. 2009. An investigation into the properties of knitted fabrics made from viscose microfibers. *Journal of Textile and Apparel, Technology and Management*,**6**(1), pp.1-9.
- RANGANATHAN, T. S., D. RAMASWAMY, K. S. JAYARAMAN, R. SANJEEVI, V. ARUMUGAM, S. DAS and A. VAIDYANATHAN. 1986. A new approach to drape. *Journal of the Textile Institute*,**77**(3), pp.226-228.
- ROBSON, D. and C. C. LONG. 2000. Drape analysis using imaging techniques. *Clothing and Textiles Research Journal*,**18**(1), pp.1-8.
- RODEL, H., V. ULBRICHT, S. KRZYWINSKI, A. SCHENK and P. FISCHER. 1998. Simulation of drape behaviour of fabrics. *International Journal of Clothing Science and Technology*,**10**(34), pp.201-208.

- ROSSI-CAMUS, J. 2010. Future beauty: 30 years of Japanese fashion: exhibition notebook part 1. *Worn through* [online]. **11**, [Accessed 04/08/2012]. Available from: <http://www.wornthrough.com/2010/11/18/future-beauty-30-years-of-japanese-fashion-exhibition-notebook-part-1/>.
- RUCKMAN, J. E., K. B. CHENG and R. MURRAY 1998. Dynamic drape measuring system. *International Journal of Clothing Science & Technology*,**10**(6), p56.
- RUPP, J. 2008a. Drylaid nonwovens. *Textiel world*,**158**(2), pp.32-34.
- RUPP, J. 2008b. Spunbond and meltblown nonwovens. *TEXTILE WORLD*,**158**(3), pp.38-40.
- RUPP, J. 2009. Versatile nonwovens for fashionable fabrics. *TEXTILE WORLD*,**159**(5), pp.20-20.
- RUSSELL, S. J. 1994. An alternative instrument for the measurement of fabric bending length. *Journal of the Textile Institute*,**85**(1), pp.82-83.
- RUSSELL, S. J. ed. 2007. *Handbook of nonwovens*. Cambridge: Woodhead.
- RUSSELL, S. J., K. J. BEVERLEY and S. SALEH. 2006. Model materials: the future prospects for nonwovens in clothing. *In: EDANA symposium, Vienna*. EDANA, pp.263-279.
- SALEH, S. 2003. *Low stress mechanical properties of hydroentangled fabrics*. Ph.D. thesis, The university of Leeds.
- SAVILLE, B. 1999. *Physical testing of textiles*. Cambridge: Woodhead Publishing.
- SCHIEFER, H. F. 1933. The Flexometer. *Textile Research Journal*,**3**(8), pp.388-403.
- SCHWARZ, E. R. 1939. Technical evaluation of textile finishing treatments. *Textile Research Journal*,**9**(6), pp.216-223.
- SENGUPTA, A. K. and A. MAJUMDAR. 1971. A study of xanthate-bonded nonwoven fabrics. *Textile Research Journal*,**41**(12), pp.956-961.
- SHARMA, K. R., B. K. BEHERA, H. ROEDEL and A. SCHENK. 2005. Effect of sewing and fusing of interlining on drape behaviour of suiting fabrics. *International Journal of Clothing Science and Technology*,**17**(1-2), pp.75-90.
- SHISHOO, R., T. DARTMAN and N. SVENSSON. 1997. Industrial-research strategies for technical textiles at TEFO/IFP. *Journal of the Textile Institute*,**88**(3), pp.103-121.
- SHYR, T. W., P. N. WANG and K. B. CHENG. 2007. A comparison of the key parameters affecting the dynamic and static drape coefficients of natural-fibre woven fabrics by a newly devised dynamic drape automatic measuring system. *Fibres and Textiles in Eastern Europe*,**15**(3), pp.81-86.
- SHYR, T. W., P. N. WANG and J. Y. LIN. 2009. Subjective and objective evaluation methods to determine the peak-trough threshold of the drape fabric node. *Textile Research Journal*,**79**(13), pp.1223-1234.
- SIDABRAITÉ, V. and V. MASTEIKAITĖ. 2003. Effect of woven fabric anisotropy on drape behaviour. *Materials science*,**9**(1), pp.111-115.
- SILVA, E. 2010. *Nonwovens in apparel*. Master thesis, North Carolina state university.

- SLATER, K. 1997. Subjective textile testing. *Journal of the Textile Institute*,**88**(2), pp.79-91.
- STUART, I. M. 1966. A loop test for bending length and rigidity. *British Journal of Applied Physics*,**17**(9), pp.1215-1221.
- STUART, I. M. and K. BAIRD. 1966. A new test for bending length. *Textile Research Journal*,**36**(1), pp.91-93.
- STUMP, D. M. and W. B. FRASER. 1996. A simplified model of fabric drape based on ring theory. *Textile Research Journal*,**66**(8), pp.506-514.
- STYLIOS, G. and T. WAN. 1997. The modelling of fabric drape on humans for virtual wear trials: the next generation of fashion technologies. *In: The 78th world conference of the textile institute in association with the 5th textile symposium of Seve and Sepve, Thessalonika*. The Institute, pp.163-173.
- STYLIOS, G., T. R. WAN and N. J. POWELL. 1995. Modelling the dynamic drape of fabrics on synthetic humans: a physical, lumped-parameter model. *International Journal of Clothing Science and Technology*,**7**(5), pp.10-25.
- STYLIOS, G. K. and N. J. POWELL. 2003. Engineering the drapability of textile fabrics. *International Journal of Clothing Science and Technology*,**15**(3-4), pp.211-217.
- STYLIOS, G. K., N. J. POWELL and L. CHENG. 2002. An investigation into the engineering of the drapability of fabric. *Transactions of the Institute of Measurement and Control*,**24**(1), pp.33-50.
- STYLIOS, G. K. and T. R. WAN. 1999. The concept of virtual measurement: 3D fabric drapeability. *International Journal of Clothing Science and Technology*,**11**(1), pp.10-18.
- STYLIOS, G. K. and R. ZHU. 1997. The characterisation of the static and dynamic drape of fabrics. *Journal of the Textile Institute*,**88**(4), pp.465-475.
- SUN, M. N. 2008. A new tester and method for measuring fabric stiffness and drape. *Textile Research Journal*,**78**(9), pp.761-770.
- TANDON, S. and M. MATSUDAIRA. 2010. Improved discrimination and prediction of drapability of fabrics. *Research journal of textile and apparel*,**14**(3), pp.62-76.
- TERMONIA, Y. 2003. Lattice model for the drape and bending properties of nonwoven fabrics. *Textile Research Journal*,**73**(1), pp.74-78.
- THE LENZING GROUP. 2012. *Lenzing quality and Lenzing innovative power set standards for manmade cellulose fibers worldwide* [online]. [Accessed 04/08/2012]. Available from: <http://www.lenzing.com/en/concern/lenzing-group.html>.
- TOKMAK, O., O. B. BERKALP and J. GERSAK. 2010. Investigation of the mechanics and performance of woven fabrics using objective evaluation techniques. Part I: The relationship between FAST, KES-F and Cusick's drape-meter parameters. *Fibres and Textiles in Eastern Europe*,**18**(2), pp.55-59.
- TORAY INDUSTRIES INC. 2006. *Knolltextiles partners with Toray Ultrasuede for contract market* [online]. [Accessed 04/08/2012]. Available from: <http://www.ultrasuede.com/news/?p=40>.

- TORRES, M. 2010. *What is fabrican?* [online]. [Accessed 04/08/2012]. Available from: <http://www.fabricanltd.com/>.
- TSAI, K. H., M. C. TSAI, P. N. WANG and T. W. SHYR. 2009. New approach to directly acquiring the drape contours of various fabrics. *Fibres and Textiles in Eastern Europe*,**17**(3), pp.54-59.
- UÇAR, N., F. KALAOÇLU, D. BAHTIYAR and O. E. BLAÇ. 2004. Investigating the drape behavior of seamed knit fabrics with image analysis. *Textile Research Journal*,**74**(2), pp.166-171.
- UNIVERSITY OF LEEDS. 2012. *Fashion with nonwovens* [online]. [Accessed 01/01/2011]. Available from: <http://www.nonwovens.leeds.ac.uk/fashionwithnonwovens/index.html>
- VANGHELuwe, L. and P. KIEKENS. 1993. Time dependence of the drape coefficient of fabrics. *International Journal of Clothing Science and Technology*,**5**(5), pp.5-8.
- VAUGHN, E. A. 1988. The relationship of textile, paper and plastic technologies to emerging nonwoven manufacturing processes. *Journal of Industrial Textiles*,**18**(2), pp.94-105.
- WEBSTER, L. 2010. Vive la différence! When it comes to apparel. *Nonwovens Industry*,**12**.
- WERNER, V. and W. JAMES. 1952. Properties of apparel wools: I. preliminary report on worsted processing trials *Textile Research Journal*,**22**(2), pp.123-137.
- WEST, B. P. V., R. B. PIPES and M. KEEFE. 1990. A simulation of the draping of bidirectional fabrics over arbitrary surfaces. *Journal of the Textile Institute*,**81**(4), pp.448 - 460.
- WINN, L. J. and E. R. SCHWARZ. 1939a. Technical evaluation of textile finishing treatments. *Textile Research Journal*,**9**(1), pp.216-223.
- WINN, L. J. and E. R. SCHWARZ. 1939b. Technical evaluation of textile finishing treatments: flexibility and drape as measurable properties of fabric. *Textile Research Journal*,**10**(1), pp.5-16.
- WINN, L. J. and E. R. SCHWARZ. 1940a. Technical evaluation of textile finishing treatments. Part III: use of rank correlation for comparison of data. *Textile Research Journal*,**10**(11), pp.453-461.
- WINN, L. J. and E. R. SCHWARZ. 1940b. Technical evaluation of textile finishing treatments. Part IV: a comparison of certain methods of measuring stiffness in fabrics. *America dyestuff reporter*,**29**, pp.469-476.
- XIAOQUN, D., F. TAKAO, M. SHIGERU, T. MASAYUKI and S. YOSHIO. 2001. Drape formation based on geometric constraints and its application to skirt modelling. *International Journal of Clothing Science and Technology*,**13**(1), p23.
- YU, W. R., T. J. KANG and K. CHUNG. 2000. Drape simulation of woven fabrics by using explicit dynamic analysis. *Journal of the Textile Institute*,**91**(2), pp.285-301.
- ZEND NON-WOVENS CO. LTD. 2011. *Nonwoven fashion could become an emerging market* [online]. [Accessed 15/12/2011]. Available from: [http://www.non-wovens.com/En\\_yeNewsInfo.asp?id=192](http://www.non-wovens.com/En_yeNewsInfo.asp?id=192).

- ZERONIAN, S. H. and J. WILKINSON. 1966. Nonwoven fabric studies. Part XI: binder distribution effects. *Textile Research Journal*,**36**(10), pp.866-873.
- ZHOU, N. and T. K. GHOSH. 1998. On-line measurement of fabric bending behaviour. *Textile Research Journal*,**68**(7), pp.533-542.
- ZIDIANAKIS, V. 2008. RRRIPP!! Paper fashion. *Eco design* [online]. [Accessed 03/03/2011]. Available from: [http://www.egodesign.ca/en/article.php?article\\_id=346](http://www.egodesign.ca/en/article.php?article_id=346)
- ZUNIC-LOJEN, D. and S. JEVSNIK. 2007. Some aspects of fabric drape. *Fibres and Textiles in Eastern Europe*,**15**(4), pp.39-45.
- ZUREK, W., D. JANKOWIAK and I. FRYDRYCH. 1985. Surface frictional resistance of fabrics woven from filament yarns. *Textile Research Journal*,**55**(2), pp.113-121.

## List of Abbreviations

<b>Abbreviation</b>	<b>Meaning</b>
A	Area
<i>AM/WH</i>	The ratio of wave amplitude to wave height
B	Bending stiffness (KES-F)
b	Back of the fabric
<i>BL</i>	Bending length (FAST)
<i>BM</i>	Bending modulus
<i>BR</i>	Bending rigidity
C	Crosswise direction
<i>Circ</i>	Circularity
CS	Circular seam
CV	Coefficient of variation
D	Drapeability
<i>D/O</i>	Dominant/Original
DC <sub>0</sub>	Static Drape coefficient
DC <sub>100</sub>	DC at 100 rpm speed
DC <sub>125</sub>	DC at 125 rpm speed
DC <sub>200</sub>	The drape coefficient at 200 rpm (dynamic drape coefficient)
DC <sub>50</sub>	DC at 50 rpm speed
DC <sub>75</sub>	DC at 75 rpm speed
DC <sub>r</sub>	The revolving drape-increase coefficient
DC <sub>s</sub>	Static conventional drape coefficient
D <sub>d</sub>	Dynamic drape coefficient with swinging motion
<i>DDC</i>	Drape distance coefficient
<i>DDR</i>	Drape distance ratio
<i>DP</i>	Drape profile
<i>DPR</i>	draped profile ratio
D <sub>sm</sub>	drape coefficient with swinging motion
<i>DU</i>	drape unevenness
<i>E100</i>	Fabric extensibility at 100 gf/cm (FAST)
<i>E20</i>	Fabric extensibility at 20 gf/cm (FAST)
<i>E5</i>	Fabric extensibility at 5 gf/cm (FAST)
EMT	Tensile strain or elongation
f	Face of the fabric
F	Fourier
<i>F/O</i>	Fourier/Original
FAST	The Fabric assurance by simple testing system
<i>FDI</i>	Fold depth index
<i>FR</i>	Formability
G	Shear stiffness/rigidity
<i>GDC</i>	Garment drape coefficient
GEA	Girth ease allowance

Gp	Fold distribution
HS	Horizontal seams (parallel to the hanging edge of cantilever sample test)
K	Polish drape coefficient
KES-F	Kawabata evaluation system of fabrics
L	Lengthwise direction
C	Linearity of stress-thickness curve (KES-F)
LSD	Least Significant Difference
LT	Linearity of stress-strain curve
Max	Maximum
Min	Minimum
MIU	Coefficient of friction (KES-F)
MMD	Mean deviation of MIU (KES-F)
N	Nodes/Folds
NN	Number of nodes
NO	Nodes' orientation
NS	Nodes' severity/size
P	Perimeter
RC	Compression resilience (KES-F)
RT	Tensile resilience
SA	Seam allowance
SMD	Surface roughness (KES-F)
SN	Seam number
ST	Surface thickness (FAST)
Sum	Sum of individual components' shear rigidities
$Sym(F - B)$	Symmetry between the face and back of a shape
$Sym(L - R)$	Symmetry between the left and right of a shape
T100	Thickness at 100 gf/cm <sup>2</sup>
T2	Thickness at 2 gf/cm <sup>2</sup>
VS	Vertical (perpendicular and parallel to the hanging edge of cantilever sample test)
W	Kendall's coefficient of concordance
WA	Wave amplitude
WC	Compression energy (KES-F)
WH	Wave height
WH/WL	This is the ratio of wave height to wavelength.
WL	Wavelength
WT	Tensile energy
30	Cusick drape test using 30 cm diameter paper ring
36	Cusick drape test using 36 cm diameter paper ring
2HB	Bending hysteresis (KES-F)
2HB 1.5	Bending hysteresis at k value 1.5 (KES-F)
2HG	Hysteresis of shear stress at 0.5 degree (KES-F)
2HG5	Hysteresis of shear stress at 5 degree (KES-F)



## Appendix A Measurement of the mechanical properties

### A.1 Measurement of the thickness (mm)

	Average T2 (mm)	T2 Standard deviation	Average T100 (mm)	T100 Standard deviation	Average surface thickness ST	ST Standard deviation
K1	0.64	0.01	0.58	0.01	0.06	0.00
K2	0.63	0.02	0.54	0.01	0.09	0.02
W1	0.33	0.02	0.28	0.01	0.05	0.01
W2	0.25	0.01	0.21	0.01	0.04	0.00
W4	0.24	0.01	0.2	0.01	0.04	0.00
N1	0.36	0.02	0.3	0.02	0.05	0.00
N2	0.37	0.03	0.28	0.02	0.09	0.01
N4	0.46	0.01	0.34	0.01	0.12	0.01
N5	0.56	0.03	0.46	0.03	0.10	0.01
N6	0.65	0.05	0.55	0.04	0.11	0.01
W3	0.54	0.06	0.50	0.05	0.03	0.04
W5	0.59	0.03	0.35	0.02	0.24	0.01

### A.2 Measurement of the extensibility

	E 5 (%)	E 20 (%)	E100 (%)	SDEV E 5 (%)	SDEV E 20 (%)	SDEV E100(%)
K1	7.6	14.5	21.1	0.55	0.64	0.26
K2	2.8	6.8	19.7	1.16	1.15	1.99
W1	3.0	6.2	10.3	3.29	6.38	8.44
W2	2.0	4.3	8.5	1.83	4.15	7.51
W3	0.0	0.06	3.11	0.00	0.07	2.98
W4	2.0	4.4	8.4	1.93	4.48	7.62
W5	0.0	0.33	3.13	0.00	0.35	2.83
N1	0.0	0.0	0.2	0.00	0.00	0.09
N2	0.0	0.4	1.7	0.00	0.20	0.56
N4	0.0	0.6	2.4	0.00	0.31	0.96
N5	0.0	0.2	1.2	0.00	0.09	0.39
N6	0.0	0.1	1.2	0.00	0.08	0.43

### A.3 Shear rigidity results (N/m)

	K1		K2		W1		W2		W4	
	EB 5	G								
Sample 1	8.3	14.82	2.5	49.2	4.4	27.95	4.1	30	4.4	27.95
Sample 2	7	17.57	2.3	53.47826	4.3	28.60	4	30.75	2.5	49.20
Sample 3	7.1	17.32	1.9	64.73684	4.1	30.00	3.2	38.4375	3.4	36.18
Sample 4	8	15.38	2.4	51.25	4	30.75	4	30.75	4	30.75
Sample 5	8.3	14.82	2.3	53.47826	3.9	31.54	3.5	35.14286	4.4	27.95
Sample 6	8	15.38	2.5	49.2	4.1	30.00	3.9	31.53846	4.3	28.60
<b>Mean</b>		15.88		53.55723		29.81		32.7698		33.44
SD		1.24		5.801559		1.33		3.319681		8.33
SE		0.10		0.483463		0.11		0.27664		0.69

### A.3 Measurement of the bending length (cm)

	Value				Standard deviation			
	Lengthwise	Crosswise	Bias 45	Arithmetic average	Lengthwise	Crosswise	Bias 45	Arithmetic average
<b>K1</b>	0.95	0.71	0.92	0.88	0.04	0.05	0.04	0.11
<b>K2</b>	1.34	1.15	0.93	1.09	0.07	0.06	0.04	0.18
<b>W1</b>	1.75	1.56	1.24	1.45	0.07	0.05	0.04	0.23
<b>W2</b>	1.84	1.50	1.21	1.44	0.08	0.05	0.02	0.27
<b>W3</b>	3.56	2.27	3.16	3.03	0.13	0.17	0.14	0.50
<b>W4</b>	2.40	1.41	1.53	1.72	0.17	0.06	0.03	0.41
<b>W5</b>	2.81	2.29	2.65	2.65	0.07	0.12	0.23	2.65
<b>N1</b>	4.51	3.75	3.53	3.83	0.12	0.12	0.21	0.44
<b>N2</b>	2.81	1.62	2.08	2.15	0.20	0.12	0.04	0.45
<b>N4</b>	2.74	2.09	2.11	2.26	0.09	0.13	0.08	0.30
<b>N5</b>	3.65	3.02	2.70	3.02	0.08	0.10	0.09	0.40
<b>N6</b>	4.10	3.23	3.38	3.52	0.49	0.08	0.22	0.44

### A.4 Measurement of the bending rigidity ( $\mu\text{Nm}$ )

	Lengthwise	Crosswise	Bias 45	Average
<b>K1</b>	2.19	0.93	2.01	1.73
<b>K2</b>	4.60	2.92	1.58	2.49
<b>W1</b>	8.03	5.65	2.85	4.53
<b>W2</b>	6.65	3.60	1.89	3.19
<b>W3</b>	110.29	28.53	77.04	68.43
<b>W4</b>	14.29	2.90	3.68	5.22
<b>W5</b>	34.30	18.73	28.99	28.99
<b>N1</b>	90.24	51.54	43.11	55.09
<b>N2</b>	17.43	3.35	7.09	7.80
<b>N4</b>	20.27	8.93	9.25	11.39
<b>N5</b>	61.95	35.22	25.04	35.02
<b>N6</b>	114.68	56.07	64.29	72.74

### A.5 Measurement of the bending modulus (Kg/cm<sup>2</sup>)

	W (gm/m <sup>2</sup> )	$\frac{L}{JBL}(\text{mm})^3$	$\frac{C}{JBL}(\text{mm})^3$	$\frac{\text{Bias}}{JBL}(\text{mm})^3$	$\frac{\text{Average BL}(\text{mm})^3}{3}$	T100 <sup>3</sup>	BM L	BM C	BM Bias 45	BM average
K1	260	858.26	364.62	789.91	677.72	0.20	1.37	0.58	1.26	1.08
K2	197	2383.28	1510.32	816.88	1288.52	0.16	3.58	2.27	1.23	1.93
W1	152	5386.03	3787.59	1911.39	3038.79	0.02	44.75	31.47	15.88	25.25
W2	108	6278.73	3394.93	1796.71	3008.84	0.01	87.87	47.51	25.00	42.11
W4	105	13872.86	2811.88	3573.77	5070.83	0.01	218.50	44.29	56.29	79.87
N1	100	92013.82	52557.05	43960.44	56170.40	0.03	408.95	233.59	195.38	249.65
N2	80	22219.38	4266.85	9041.96	9937.99	0.02	97.17	18.66	39.54	43.46
N4	100	20672.95	9107.60	9436.95	11617.26	0.04	63.12	27.81	28.81	35.47
N5	130	48590.84	27628.65	19643.35	27465.49	0.10	77.88	44.28	31.48	44.02
N6	170	68785.45	33630.19	38560.12	43632.43	0.17	84.34	41.24	47.28	53.50
W3	250	44983.76	11636.07	31422.99	27912.70	0.128	105.41	27.27	73.63	65.41
W5	158	22138.64	12087.18	18710.81	18710.81	0.043	96.52	52.70	81.57	81.57

### A.6 Measurement of the formability (mm<sup>2</sup>)

	BR( $\mu$ Nm)				E20-E5				Formability(mm)			
	L	C	Bias	Average	L	C	Bias	Average	Lengthwise	Crosswise	Bias 45	Average
K1	2.19	0.93	2.01	1.73	6.08	6.85	7.23	6.85	0.91	0.43	0.99	0.81
K2	4.60	2.92	1.58	2.49	3.90	3.95	4.03	3.98	1.22	0.78	0.43	0.67
W1	8.03	5.65	2.85	4.53	1.68	0.73	3.40	3.17	0.92	0.28	0.66	0.98
W2	6.65	3.60	1.89	3.19	0.80	0.63	5.00	2.35	0.36	0.15	0.64	0.51
W4	14.29	2.90	3.68	5.22	0.52	0.53	5.40	2.44	0.50	0.11	1.35	0.87
N1	90.24	51.54	43.11	55.09	0.00	0.00	0.00	0.00	0.00	0.00	0.00	0.00
N2	17.43	3.35	7.09	7.80	0.15	0.43	0.58	0.44	0.18	0.10	0.28	0.23
N4	20.27	8.93	9.25	11.39	0.13	0.55	0.83	0.59	0.18	0.33	0.52	0.46
N5	61.95	35.22	25.04	35.02	0.13	0.27	0.12	0.16	0.56	0.64	0.20	0.38
N6	114.68	56.07	64.29	72.74	0.03	0.20	0.17	0.14	0.26	0.76	0.73	0.70
W3	110.29	28.53	77.04	68.43	0	0	0.12	0.06	0.00	0.00	0.61	0.27
W5	34.30	18.73	28.99	28.99	0	0	0.65	0.325	0.00	0.00	1.28	0.64

## Appendix B Measurement of the drape coefficient

### B.1 Measurement of the drape coefficient 30

	Dc face	SDEV	SE	DC Back	SDEV	SE	overall average	SDEV	SE
<b>K1</b>	11.04	0.11	0.02	12.27	0.18	0.04	11.65	0.65	0.07
<b>K2</b>	12.65	0.11	0.03	12.26	0.19	0.04	12.46	0.25	0.03
<b>W1</b>	26.75	0.19	0.04	27.14	0.18	0.04	26.95	0.27	0.03
<b>W2</b>	30.10	0.30	0.07	29.51	0.28	0.06	29.81	0.42	0.05
<b>W4</b>	35.26	0.33	0.07	35.27	0.27	0.06	35.27	0.29	0.03
<b>N1</b>	98.62	0.20	0.04	98.71	0.19	0.04	98.66	0.20	0.02
<b>N2</b>	82.58	0.28	0.06	83.65	0.13	0.03	83.12	0.59	0.07
<b>N4</b>	84.62	0.30	0.07	84.94	0.41	0.09	84.78	0.39	0.04
<b>N5</b>	94.41	0.39	0.09	91.39	0.32	0.07	92.90	1.59	0.18
<b>N6</b>	97.51	0.41	0.09	93.57	0.37	0.08	95.54	2.06	0.23
<b>W3</b>	84.09	2.26	0.50	85.93	8.40	1.87	85.01	6.04	0.67
<b>W5</b>	76.68	3.23	0.72	82.57	4.72	1.05	79.63	4.96	0.55

### B.2 Measurement of the drape coefficient 36

	DC 36% Face	SDEV	DC 36% Back	SDEV	Average	SDEV
<b>N1</b>	99.15	0.74	95.24	3.39	97.20	3.10
<b>N2</b>	65.26	3.36	63.58	3.55	64.42	3.41
<b>N4</b>	58.74	6.48	62.20	4.45	60.47	5.60
<b>N5</b>	84.21	3.71	82.62	3.83	83.42	3.69
<b>N6</b>	90.19	1.12	86.15	0.42	88.17	2.26

## Appendix C Measurement of the drape values

### C.1 Fabric drape values measurement

Average values of each fabric																							
Perimeter	Circularity	Area	Peaks	Sym (F-B)	Sym (R-L)	WH A	WH Max	WH Min	WH CV	WA A	WA Max	WA Min	WA CV	WA	WL A	WL Max	WL Min	WL CV	AM/WH	WH/WH	Fourier	F/O	D/O
K1	86.57	0.51	306.37	10.60	0.91	9.96	10.08	9.78	0.01	0.33	0.48	0.15	0.36	34.04	57.70	21.34	0.32	0.05	0.32	9.23	0.001285	0.50	
K2	87.33	0.51	309.34	12.40	0.95	9.98	10.06	9.88	0.01	0.28	0.49	0.08	0.48	29.31	45.66	16.62	0.28	0.05	0.37	11.68	0.001687	0.49	
N1	96.64	0.91	673.60	0.00	0.99	0.99	0.00	0.00	0.00	0.00	0.00	0.00	0.00	0.00	0.00	0.00	0.00	0.00	0.00	0.00	0.000000	0.00	
N2	94.17	0.88	617.84	4.20	0.95	14.17	14.78	13.50	0.05	0.66	1.39	0.07	1.06	91.20	174.90	32.80	0.72	0.10	0.25	15.76	0.001954	0.44	
N4	93.55	0.88	615.74	3.80	0.96	0.95	14.11	14.74	13.55	0.04	0.68	1.27	0.06	96.00	165.45	37.37	0.62	0.09	0.22	13.45	0.001159	0.44	
N5	97.18	0.90	676.54	0.80	0.99	8.73	8.76	8.70	0.01	0.17	0.21	0.13	0.37	180.00	205.10	154.30	0.33	0.02	0.05	2.55	0.000209	0.26	
N6	97.72	0.90	685.58	0.00	0.99	0.99	0.00	0.00	0.00	0.00	0.00	0.00	0.00	0.00	0.00	0.00	0.00	0.00	0.00	0.00	0.000000	0.00	
W1	96.20	0.51	373.09	7.60	0.82	0.80	11.12	11.37	10.94	0.01	1.29	1.65	0.66	47.57	64.18	33.37	0.23	0.15	0.25	36.84	0.004100	0.45	
W2	96.30	0.52	384.67	7.00	0.90	0.84	11.25	11.50	11.06	0.02	1.33	1.67	0.80	51.43	68.04	37.23	0.21	0.15	0.23	31.04	0.003406	0.44	
W3	93.98	0.87	614.00	2.60	0.96	13.78	14.15	13.47	0.03	1.18	1.48	0.81	0.43	173.42	297.65	85.87	0.67	0.11	0.15	14.30	0.001226	0.43	
W4	95.10	0.56	403.54	7.00	0.84	0.80	11.54	11.99	11.13	0.03	1.34	1.79	0.78	51.86	67.75	37.24	0.22	0.16	0.23	36.86	0.003967	0.45	
W5	94.33	0.65	601.22	2.60	0.81	0.79	13.69	14.13	13.32	0.03	1.61	2.02	1.08	144.00	188.18	100.93	0.35	0.15	0.11	25.66	0.002308	0.44	
Coefficient of variation																							
Perimeter	Circularity	Area	Peaks	Sym (F-B)	Sym (R-L)	WH A	WH Max	WH Min	WH CV	WA A	WA Max	WA Min	WA CV	WA	WL A	WL Max	WL Min	WL CV	AM/WH	WH/WH	Fourier	F/O	D/O
K1	0.01	0.02	0.01	0.05	0.02	0.01	0.00	0.00	0.00	0.16	0.17	0.24	0.27	0.11	0.05	0.10	0.21	0.17	0.19	0.06	0.20	0.20	0.01
K2	0.00	0.00	0.00	0.11	0.00	0.01	0.00	0.00	0.00	0.08	0.05	0.02	0.38	0.11	0.11	0.23	0.18	0.23	0.02	0.11	0.06	0.06	0.00
N1	0.00	0.00	0.00	0.00	0.00	0.00	0.00	0.00	0.00	0.00	0.00	0.00	0.00	0.00	0.00	0.00	0.00	0.00	0.00	0.00	0.00	0.00	0.00
N2	0.00	0.00	0.00	0.26	0.01	0.01	0.01	0.01	0.00	0.08	0.21	0.02	0.18	0.15	0.29	0.39	0.09	0.34	0.01	0.11	0.10	0.10	0.01
N4	0.01	0.01	0.02	0.12	0.01	0.01	0.01	0.00	0.01	0.17	0.11	0.04	0.41	0.09	0.14	0.18	0.28	0.25	0.03	0.26	0.06	0.06	0.01
N5	0.01	0.00	0.01	1.05	0.00	0.01	0.91	0.91	0.91	1.73	0.94	0.95	1.23	1.73	1.00	0.92	1.22	1.73	0.95	1.36	0.92	0.92	0.91
N6	0.00	0.00	0.00	0.00	0.00	0.00	0.00	0.00	0.00	0.00	0.00	0.00	0.00	0.00	0.00	0.00	0.00	0.00	0.00	0.00	0.00	0.00	0.00
W1	0.00	0.02	0.02	0.07	0.02	0.07	0.01	0.01	0.01	0.18	0.10	0.04	0.33	0.26	0.07	0.28	0.14	0.51	0.06	0.06	0.12	0.12	0.01
W2	0.01	0.02	0.01	0.00	0.05	0.08	0.00	0.01	0.00	0.18	0.06	0.03	0.11	0.09	0.00	0.11	0.08	0.22	0.04	0.02	0.19	0.20	0.01
W3	0.00	0.01	0.02	0.34	0.03	0.02	0.05	0.01	1.12	0.28	0.10	0.93	1.23	0.19	0.56	0.61	0.55	0.11	0.61	0.10	0.11	0.11	0.03
W4	0.00	0.02	0.02	0.10	0.07	0.05	0.01	0.02	0.01	0.26	0.08	0.08	0.16	0.06	0.10	0.13	0.09	0.09	0.10	0.10	0.10	0.10	0.01
W5	0.00	0.01	0.02	0.21	0.04	0.05	0.02	0.04	0.01	0.60	0.21	0.05	0.68	0.75	0.23	0.31	0.10	0.55	0.00	0.16	0.08	0.09	0.01

## C.2 Garment drape values measurement

Average values of each dress																							
	Perimeter	Circumference	Area	Peaks	Sym (F-B)	Sym (R-L)	WHA	WH Max	WH Min	WVCV	VAA	WA Max	WAMin	WACV	VLA	VL Max	VL Min	WLCV	AMWH	WHML	Fourier F/O	D/D	
K1	218.67	0.36	1353.13	10.00	0.63	0.59	21.17	23.02	18.53	0.08	2.93	5.55	1.35	0.44	59.77	302.27	20.15	1.07	0.29	0.66	123.28	0.003	0.20
K2	199.66	0.34	1076.78	11.80	0.73	0.64	19.00	21.29	16.18	0.09	2.56	4.55	0.48	0.55	30.63	48.49	14.86	0.33	0.31	0.72	120.77	0.004	0.22
M1	185.15	0.54	1460.76	5.00	0.59	0.56	23.57	26.02	20.57	0.11	5.25	9.23	3.28	0.46	95.16	202.45	51.96	0.45	0.40	0.33	110.67	0.003	0.25
M2	166.02	0.42	1008.38	6.40	0.74	0.60	18.83	21.40	16.69	0.10	3.88	6.02	1.76	0.40	57.26	111.05	25.70	0.56	0.33	0.45	114.80	0.005	0.31
M4	186.77	0.47	1314.32	5.00	0.74	0.65	21.77	24.52	18.98	0.11	5.09	7.49	2.46	0.39	73.20	115.89	39.88	0.44	0.36	0.37	104.55	0.003	0.24
M5	185.65	0.55	1513.10	6.00	0.72	0.58	23.57	26.88	20.66	0.10	4.06	7.91	0.58	0.65	60.69	93.23	24.11	0.44	0.34	0.52	100.02	0.003	0.24
M6	188.10	0.54	1513.09	6.60	0.78	0.56	22.82	24.86	19.83	0.09	3.66	7.42	1.27	0.66	54.86	90.37	25.97	0.43	0.33	0.52	101.15	0.003	0.24
W1	197.68	0.36	1117.60	7.40	0.71	0.76	20.15	21.98	18.38	0.07	3.83	6.30	0.69	0.53	48.86	95.18	31.27	0.53	0.36	0.50	129.10	0.004	0.22
W2	192.98	0.36	1070.75	6.20	0.72	0.61	18.83	20.42	17.16	0.06	4.28	6.17	2.22	0.37	58.29	117.09	33.23	0.51	0.34	0.38	109.80	0.004	0.23
W3	187.90	0.52	1461.67	4.80	0.70	0.42	22.66	25.22	19.94	0.10	5.57	7.92	3.72	0.32	79.20	123.22	43.98	0.40	0.36	0.36	113.32	0.003	0.23
W4	186.80	0.40	1115.44	6.60	0.69	0.67	19.72	21.98	18.15	0.07	3.10	5.24	0.62	0.54	73.63	204.91	20.28	0.72	0.27	0.49	113.19	0.004	0.23
W5	187.61	0.52	1460.25	5.00	0.77	0.43	22.84	25.77	20.86	0.09	4.98	6.55	3.55	0.25	95.90	222.43	46.31	0.56	0.33	0.34	100.12	0.003	0.24
Coefficient of variation																							
	Perimeter	Circumference	Area	Peaks	Sym (F-B)	Sym (R-L)	WHA	WH Max	WH Min	WVCV	VAA	WA Max	WAMin	WACV	VLA	VL Max	VL Min	WLCV	AMWH	WHML	Fourier F/O	D/D	
K1	0.01	0.04	0.02	0.07	0.05	0.04	0.01	0.02	0.01	0.13	0.07	0.20	0.07	0.17	0.17	0.52	1.11	0.08	0.89	0.06	0.04	0.04	0.04
K2	0.07	0.05	0.16	0.07	0.06	0.02	0.09	0.10	0.10	0.23	0.06	0.08	0.15	0.12	0.07	0.12	0.47	0.19	0.07	0.20	0.07	0.17	0.08
M1	0.00	0.05	0.05	0.00	0.06	0.13	0.02	0.02	0.02	0.09	0.05	0.05	0.17	0.13	0.54	1.23	0.12	1.16	0.05	0.08	0.07	0.08	0.02
M2	0.31	0.07	0.47	0.14	0.03	0.03	0.32	0.32	0.32	0.14	0.31	0.34	0.43	0.11	0.16	0.40	0.34	0.38	0.11	0.37	0.34	0.51	0.53
M4	0.01	0.03	0.04	0.14	0.05	0.06	0.03	0.04	0.03	0.20	0.12	0.11	0.58	0.36	0.15	0.23	0.41	0.40	0.11	0.24	0.10	0.11	0.02
M5	0.01	0.07	0.07	0.12	0.08	0.09	0.04	0.06	0.04	0.22	0.16	0.17	0.98	0.17	0.12	0.11	0.25	0.06	0.19	0.14	0.17	0.20	0.01
M6	0.00	0.05	0.05	0.08	0.05	0.06	0.03	0.01	0.05	0.23	0.13	0.08	0.35	0.18	0.09	0.16	0.31	0.32	0.06	0.19	0.10	0.11	0.01
W1	0.00	0.01	0.01	0.07	0.03	0.05	0.01	0.02	0.01	0.09	0.08	0.04	0.40	0.15	0.07	0.04	0.06	0.08	0.04	0.03	0.02	0.02	0.00
W2	0.01	0.03	0.03	0.07	0.03	0.04	0.01	0.01	0.02	0.09	0.08	0.08	0.29	0.19	0.07	0.02	0.13	0.12	0.02	0.12	0.05	0.06	0.01
W3	0.00	0.06	0.06	0.23	0.06	0.08	0.02	0.05	0.02	0.23	0.10	0.14	0.18	0.25	0.30	0.38	0.38	0.45	0.11	0.23	0.20	0.19	0.01
W4	0.01	0.05	0.05	0.08	0.07	0.01	0.02	0.03	0.03	0.10	0.11	0.10	1.16	0.25	0.61	1.19	0.39	0.65	0.10	0.15	0.10	0.11	0.02
W5	0.00	0.05	0.05	0.05	0.00	0.06	0.04	0.01	0.01	0.11	0.07	0.10	0.02	0.16	0.56	1.10	0.05	0.81	0.08	0.08	0.10	0.12	0.01





## D.2 Physical garment drapeability

Observer	Stimulus											
	K1	K2	W1	W2	W4	W3	W5	N1	N2	N4	N5	N6
Judge 1	1	2	6	5	3	12	10	11	4	7	8	9
Judge 2	2	1	4	3	5	12	7	11	6	10	9	8
Judge 3	1	2	3	5	4	9	8	11	6	7	10	12
Judge 4	1	2	5	3	4	10	9	11	6	7	8	12
Judge 5	1	2	5	4	3	10	11	7	9	6	12	8
Judge 6	1	2	5	3	4	8	6	12	10	7	11	9
Judge 7	1	2	8	5	3	10	9	6	4	7	12	11
Judge 8	1	2	4	5	3	12	9	11	8	7	6	10
Judge 9	1	2	5	4	3	8	11	9	7	6	12	10
Judge 10	2	1	5	4	3	8	10	12	7	9	6	11
Judge 11	2	1	3	4	5	7	12	11	6	9	10	8
Judge 12	1	2	5	3	4	8	6	12	7	10	9	11
Judge 13	2	1	3	5	4	7	6	12	10	8	11	9
Judge 14	1	2	4	5	3	12	8	9	10	6	7	11
Judge 15	1	2	3	5	4	10	7	9	6	11	12	8
Judge 16	1	2	4	3	5	11	8	9	7	6	12	10
Judge 17	1	2	5	4	3	11	10	8	6	7	12	9
Judge 18	1	2	4	3	5	12	9	8	6	7	10	11
Judge 19	1	2	4	5	3	10	12	9	8	7	11	6
Judge 20	1	3	7	6	2	4	8	12	9	5	11	10
R Average	1.2	1.85	4.6	4.2	3.65	9.55	8.8	10	7.1	7.45	9.95	9.65
Rj	24	37	92	84	73	191	176	200	142	149	199	193
Ri-R'	11236	8649	1444	2116	3249	3721	2116	4900	144	361	4761	3969
Sum(Ri-R')	46666											
W	0.816											
W'	0.816											
Fstat	84.14											
r	20											
n	12											
K1	10.9											
K2	207.1											
Fcritic	2.408											

Kendall W = 0.8158  
ChiSq=179.4846  
df=11  
p=<0.0001

### D.3 Assessment of fabric drapéability using images

Observer	Stimulus											
	K1	K2	W1	W2	W4	W3	W5	N1	N2	N4	N5	N6
Judge 1	1	2	3	5	4	7	6	10	8	9	11	12
Judge 2	1	2	3	4	5	9	6	10	7	8	11	12
Judge 3	2	1	3	5	4	9	6	10	7	8	11	12
Judge 4	1	2	3	4	5	9	7	11	6	8	10	12
Judge 5	5	4	1	2	3	7	6	11	9	8	10	12
Judge 6	1	2	3	4	5	8	9	12	6	7	11	10
Judge 7	4	5	3	2	1	6	7	10	8	9	11	12
Judge 8	5	4	3	1	2	8	9	10	7	6	11	12
Judge 9	2	1	3	4	5	6	7	10	9	8	11	12
Judge 10	1	2	3	4	5	9	6	10	7	8	11	12
Judge 11	1	2	3	4	5	6	7	10	8	9	11	12
Judge 12	1	2	3	4	5	8	9	10	6	7	11	12
Judge 13	1	2	3	4	5	9	7	11	6	8	10	12
Judge 14	1	2	3	4	5	9	6	10	7	8	11	12
Judge 15	2	1	3	4	5	7	6	12	9	8	10	11
Judge 16	1	2	3	4	5	9	8	12	7	6	11	10
Judge 17	2	1	4	3	5	9	6	12	7	8	11	10
Judge 18	2	1	3	5	4	7	9	10	6	8	11	12
Judge 19	1	2	3	4	5	7	6	11	9	8	10	12
Judge 20	2	1	3	5	4	9	6	10	7	8	11	12
R Average	1.85	2.05	2.95	3.8	4.35	7.9	6.95	10.6	7.3	7.85	10.8	11.65
Rj	37	41	59	76	87	158	139	212	146	157	215	233
Ri-R'	8649	7921	5041	2916	1849	784	81	6724	256	729	7225	10609
Sum(Ri-R')	52784											
W	0.9228											
W'	0.92275											
Fstat	226.947											
r	20											
n	12											
K1	10.9											
K2	207.1											
Fcrtic	2.40754											

Kendall W = 0.9228  
 ChiSq=203.0154  
 df=11  
 p=<<0.0001

### D.4 Assessment of garment drapeability using images

Observer	Stimulus											
	K1	K2	W1	W2	W4	W3	W5	N1	N2	N4	N5	N6
Judge 1	5	4	2	3	1	7	11	12	6	9	8	10
Judge 2	4	1	3	5	2	9	11	12	6	7	10	8
Judge 3	1	2	6	4	3	8	10	12	5	9	11	7
Judge 4	1	2	5	4	6	8	10	12	7	9	11	3
Judge 5	2	1	4	5	3	8	11	12	6	9	10	7
Judge 6	2	1	5	3	4	8	11	12	6	9	10	7
Judge 7	2	1	3	5	4	10	11	12	7	9	8	6
Judge 8	2	1	5	4	3	8	11	12	6	9	10	7
Judge 9	2	1	5	4	3	10	11	12	6	8	9	7
Judge 10	2	1	5	3	4	11	10	12	7	9	8	6
Judge 11	1	2	5	3	4	8	9	12	7	11	10	6
Judge 12	1	2	4	3	5	8	11	12	7	9	10	6
Judge 13	2	1	3	5	4	9	11	12	6	10	8	7
Judge 14	2	1	5	3	4	9	10	12	6	8	11	7
Judge 15	2	1	5	3	4	8	10	12	6	9	11	7
Judge 16	2	1	3	4	4	8	10	12	6	9	11	7
Judge 17	2	1	3	5	4	10	11	12	7	9	8	6
Judge 18	2	1	4	5	3	8	11	12	6	9	10	7
Judge 19	2	1	5	3	4	8	11	12	7	9	10	6
Judge 20	2	1	4	3	5	10	8	12	6	11	9	7
R Average	2.05	1.35	4.2	3.85	3.7	8.65	10.45	12	6.3	9.05	9.65	6.7
SDEV	0.9445	0.7452	1.0563	0.8751	1.0809	1.04	0.8256	0	0.5712	0.887	1.1367	1.2607
SE	0.2112	0.1666	0.2362	0.1957	0.2417	0.2325	0.1846	0	0.1277	0.1983	0.2542	0.2819
Rj	41	27	84	77	74	173	209	240	126	181	193	134
Ri-R'	7921	10609	2116	2809	3136	1849	6241	12100	16	2601	3969	16
Sum(Ri-R')	53383											
W	0.9333											
W'	0.9332											
Fstat	265.51											
r	20											
n	12											
K1	10.9											
K2	207.1											
Fcrtic	2.4075											

Kendall W = 0.9315  
 ChiSq=204.9378  
 df=11  
 p=<0.0001

### D.5 Assessment of garment drape preference

Observer	Stimulus											
	K1	K2	W1	W2	W4	W3	W5	N1	N2	N4	N5	N6
Judge 1	10	11	6	7	12	8	9	4	2	3	5	1
Judge 2	2	1	5	3	4	12	8	10	6	7	9	11
Judge 3	5	4	1	3	2	12	10	8	6	7	9	11
Judge 4	2	1	5	7	6	12	11	10	9	8	4	3
Judge 5	5	4	3	2	1	12	11	9	7	6	8	10
Judge 6	10	6	5	1	4	7	3	12	8	9	11	2
Judge 7	2	1	7	6	12	11	10	5	9	4	3	8
Judge 8	1	2	3	4	5	12	7	11	10	6	8	9
Judge 9	7	1	3	6	4	2	5	10	11	12	9	8
Judge 10	10	12	3	1	4	2	6	9	7	8	11	5
Judge 11	3	2	1	6	5	8	12	9	7	4	11	10
Judge 12	4	2	3	7	1	6	5	11	9	8	12	10
Judge 13	2	6	3	5	1	7	4	11	10	8	12	9
Judge 14	7	1	3	5	4	12	6	11	2	8	9	10
Judge 15	11	10	2	1	3	8	5	7	4	9	12	6
Judge 16	4	5	6	2	3	7	11	8	1	9	12	10
Judge 17	12	8	7	6	1	4	10	9	3	5	11	2
Judge 18	11	12	2	1	3	8	6	10	4	7	9	5
Judge 19	12	8	2	9	11	1	10	3	5	4	7	6
Judge 20	1	8	9	4	5	7	3	2	10	11	12	6
R Average	6.05	5.25	3.95	4.3	4.55	7.9	7.6	8.45	6.5	7.15	9.2	7.1
R <sub>j</sub>	121	105	79	86	91	158	152	169	130	143	184	142
R <sub>i</sub> -R <sub>i'</sub>	81	625	2601	1936	1521	784	484	1521	0	169	2916	144
Sum(R <sub>i</sub> -R <sub>i'</sub> )	12782											
W	0.223											
W'	0.223											
F stat	5.467											
r	20											
n	12											
K1	10.9											
K2	207.1											
F <sub>critic</sub>	2.408											

Kendall W = 0.2235

ChiSq= 49.1615

df= 11

p<0.0001

## Appendix E Prediction of fabric and garment drapeability

### E.1 Regression analysis of garments images' rank scores on the drape values measured for the respective images

Dependent Variable	Independent Variables	Unstandardised Coefficients		Standardised Coefficients	t	Sig	R <sup>2</sup>
		B (Coefficient value)	Std. Error	Beta			
All	(Constant)	-9.721	1.627		-5.976	0	0.93
	Circularity	27.607	4.367	0.668	6.321	0	
	WLMIN	0.122	0.031	0.411	3.890	0.004	
Conventional	(Constant)	-14.131	0		.	.	1
	Circularity	25.329	0	0.594	.	.	
	WLMIN	0.280	0	1.010	.	.	
	WAA	-1.954	0	-0.645	.	.	
	D/O	31.031	0	0.106	.	.	
	Fourier	0.008	0	0.023	.	.	
	WAMAX	0.005	0	0.002	.	.	
Nonwovens	(Constant)	-31.286	3.659		-8.551	0.013	0.99
	AM/WH	121.706	11.701	1.439	10.401	0.009	
	WAMIN	-1.431	0.308	-0.642	-4.644	0.043	

### E.2 Regression analysis of fabrics images' rank scores on the drape values measured for the respective images

Dependent Variable	Independent Variables	Unstandardised Coefficients		Standardised Coefficients	t	Sig	R <sup>2</sup>
		B (Coefficient value)	Std. Error	Beta			
All	(Constant)	10.072	0.862		11.689	0	0.74
	Peaks no	-0.731	0.138	-0.859	-5.302	0	
Conventional	(Constant)	0.569	0.331		1.718	0.161	0.98
	WHCV	264.043	20.078	1.223	13.151	0	
	WLMAX	-0.012	0.002	-0.470	-5.050	0.007	
Nonwovens	(Constant)	-26.901	3.149		-8.542	0.003	0.98
	Area	0.056	0.005	0.989	11.612	0.001	

**E.3 Regression analysis of garments images' rank scores on the mechanical properties measured for the respective images**

Dependent Variable	Independent Variables	Unstandardised Coefficients		Standardised Coefficients	t	Sig	R <sup>2</sup>
		B (Coefficient value)	Std. Error	Beta			
All	(Constant)	-0.568	1.366		-0.416	0.003	0.76
	<i>BL</i>	0.313	.056	0.87	5.591	0.016	
Conventional	(Constant)	-2.043320	1.248169			-1.637054	0.88
	<i>BL</i>	0.395901	0.065607		0.937693	6.034391	
Nonwovens	No variables were entered into the equation.						

**E.4 Regression analysis of fabrics images' rank scores on the mechanical properties measured for the respective images**

Dependent Variable	Independent Variables	Unstandardised Coefficients		Standardised Coefficients	t	Sig	R <sup>2</sup>
		B (Coefficient value)	Std. Error	Beta			
All	(Constant)	-3.178	1.843		-1.725	0.119	0.88
	<i>BL</i>	0.534	0.117	1.492	4.570	0.001	
	<i>BR</i>	-0.096	0.042	-0.745	-2.281	0.048	
Conventional	(Constant)	-2.566	1.239		-2.071	0.107	0.97
	<i>BR</i>	0.106	0.014	1.549	7.824	0.001	
	<i>E100</i>	0.220	0.064	0.679	3.429	0.027	
Nonwovens	(Constant)	7.279	0.627		11.610	0.001	0.87
	<i>BR</i>	0.065	0.014	0.934	4.546	0.020	