

This is the submitted version of the article: Catalán, E.; Komilis, D. and Sánchez, A. *Solid state fermentation and composting as alternatives to treat hair waste: a LCA comparative approach in Waste management and research*, vol. 35, issue 7 (2017), p. 786-790

Available at: <https://dx.doi.org/10.1177/0734242X17709909>

© 2017. This manuscript version is made available under the “All rights reserved” license

**Solid state fermentation and composting as alternatives to treat hair waste: A LCA  
comparative approach**

Eva Catalán, Dimitrios Komilis, Antoni Sánchez\*

Composting Research Group

Department of Chemical, Biological and Environmental Engineering

Universitat Autònoma de Barcelona

08193 Barcelona (Spain)

\*Corresponding author: [antoni.sanchez@uab.cat](mailto:antoni.sanchez@uab.cat)

## **Abstract**

One of the wastes associated with leather production in tannery industries is the hair residue generated during the dehairing process. Hair wastes are mainly dumped or managed through composting but recent studies propose the treatment of hair wastes through solid state fermentation (SSF) to obtain proteases and compost. These enzymes are suitable for its use in an enzymatic dehairing process, as an alternative to the current chemical dehairing process. In the present work, two different scenarios for the valorization of the hair waste are proposed and assessed by means of Life Cycle Assessment (LCA): composting and SSF for protease production. Detailed data on hair waste composting and on SSF protease production is gathered from previous studies performed by our research group and from a literature survey. Background inventory data is mainly based on Ecoinvent version 3 from software SimaPro® 8. The main aim of this study was to identify which process results in the highest environmental impact. The SSF process was found to have lower environmental impacts than composting, due to the fact that the enzyme use in the dehairing process prevents the use of chemicals traditionally used in the dehairing process. This permits to reformulate an industrial process from the classical approach of waste management to a novel alternative based on circular economy.

**Keywords:** LCA, solid state fermentation, dehairing, tanning industry, hair waste.

## **Introduction**

Large amounts of industrial organic wastes are produced worldwide that can be managed by biological treatment technologies. Composting and solid state fermentation (SSF) are common procedures for organic waste treatment. The main aim of composting is to reduce the volume of these residues, stabilize organic matter and produce compost for agricultural use. The goal of SSF is to recover biologically active secondary metabolites (e.g. enzymes) from an organic substrate during the composting process using some type of extracting agent (Singhania et al., 2009). SSF can result in the production of enzymes from a solid substrate in the absence of free water (Renge et al., 2012). A compost can be produced after the extraction as long as the composting process continues; however, compost production is not the main target of SSF as is in traditional composting. SSF has proven to be a very promising technology in the development of several bioprocesses and products, since it has a high potential for the production of enzymes, among other compounds (Bisen and Sharma, 2014).

The leather industry has been associated to high pollutant loads mainly due to the use of chemicals during the dehairing stage and the production of high amounts of solid waste, among them hair waste. Leather processing involves a series of unit operations that can be classified as: beamhouse operations, which clean the hides or skins; tanning, which stabilizes the skin or hide and post-tanning operations where aesthetic value is added. The beamhouse operations include the soaking, the green fleshing, the dehairing and the liming stage. The soaking stage is the most polluting stage of the process since it contributes to a 50-55% of the total pollution (Chowdhury et al., 2015) due to chemical products used for the treatment of hide, such as lime, sodium carbonate, sodium hydroxide, etc. In the liming stage, hair, skin and an emulsion fats are removed from the hides and are released in the effluent thus increasing the total pollutant load (Chowdhury et al., 2013). Hair waste is an adequate source of protein with a dry matter (DM) content between 65-95%

wb (Dawber, 1996). Recent studies have proven the efficiency of the use of hair waste in SSF to produce alkaline proteases, which can be used in the dehairing process (Abu Yazid et al., 2016).

The main objective of the current study is to compare the environmental impacts associated with the different possible scenarios for the management of hair waste produced by a typical leather industry. The two processes (treatment scenarios) considered in this work are: a) composting by means of a turned windrow or an in-vessel system and b) SSF with the goal of producing enzymes and a potential soil amendment after addition of sludge obtained from the wastewater treatment plant of a real tanning industry. The novelty of this work is to change from the classical paradigm of waste treatment to a new technology that permits to reformulate an industrial process from the point of view of circular economy. The use of experimental data for LCA makes it more consistent and reliable than other similar studies. It is clarified that SSF is practically a composting process but with a different objective than traditional composting.

## **Methodology**

### *LCA software*

A LCA methodology was followed to compare the environmental impacts of the aforementioned scenarios. The software SimaPro© 8 was used and environmental impacts were calculated according to the ReCiPe methodology. Concerning the database and method used with SimaPro, the Ecoinvent version 3 was adopted since it has a wide database and covers several areas. The ReCiPe methodology is a follow up of Eco-Indicator 99 and CML methods. ReCiPe has two levels of indicators: i) Midpoint indicators ii) Endpoint indicators. At the midpoint level, 18 impact categories are used (PRé Consultants, 2015). The midpoint level was selected in this work.

### *System boundaries and technical assumption*

The inputs and outputs of all materials during a typical leather dehairing process were obtained from a tannery industry in Igualada (Barcelona, Spain). It is important to note that the study focuses on the treatment of hair waste by two technologies (composting and SSF). This specific industry adopts windrow composting to treat the hair waste generated. Previous studies have demonstrated that compost from hair waste is a suitable for agricultural purposes containing considerable amounts of organic matter and nitrogen with a high level of stability and maturity (Barrena et al., 2007a; Barrena et al., 2007b). The Leather Tanner's Union in Igualada treats 100 t per day of raw leather and around 14 t per day of hair wastes are produced during the process (Abraham et al., 2014). The compost produced by the industry is currently given for free to land farmers. Data related to the environmental burdens of the SSF have been based on laboratory experiments obtained by the research group, as further commented.

Regarding the LCI (Life Cycle Inventory), transportation of hair waste, bulking agent, compost and enzyme was not accounted for in any of the scenarios considered. The enzymes were considered to be internally used within the leather industry to replace chemicals typically used during dehairing. The two possible scenarios to manage hair waste produced in this industry are shown in Figure 1.

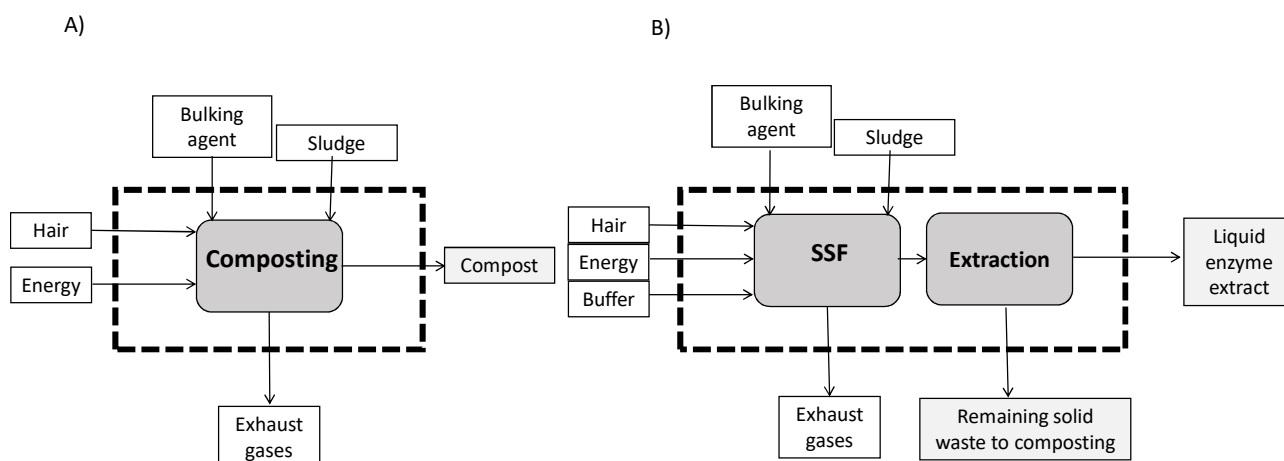

**FIGURE 1:** Flow diagram of the two possible scenarios to treat hair waste from a leather industry. A) Composting process (existing scenario in Igualada), B) SSF alternative process. Dashed lines indicate the boundaries of the LCA applied here.

### *LCA assumptions*

In this study, the functional unit (FU) was 100 kg of raw leather after the dehairing stage in a tannery industry.

The same reactor was considered for SSF and for in-vessel composting. Pre-treatment was considered to be performed with an 80 mm trommel screen and post-treatment with a 10 mm trommel followed by a ballistic separator (Colón et al., 2012). The data on gaseous emissions during SSF and composting are available in the literature (Colón et al., 2012; Maulini-Duran et al., 2015). The input data, which are similar for both scenarios, are presented in Table 1.

**TABLE 1.** Input data to the SimaPro model for all three scenarios. HW: hair waste, WS: wet sludge, BA: bulking agent, VOC: volatile organic compounds and FU: functional unit.

	Value	Unit	Data Source
HW generated	13.7	kg/FU	Abraham et al. (2014)
WS required during composting / SSF	26	kg/FU	Abraham et al. (2014)
BA required during composting / SSF	9.7	kg/FU	Calculated
Compost obtained (wet basis)	48.7	kg/FU	Calculated
VOC	0.003992	kg/FU	Maulini-Duran et al. (2015)
CH <sub>4</sub>	0.000072	kg/FU	Maulini-Duran et al. (2015)
N <sub>2</sub> O	0.000042	kg/FU	Maulini-Duran et al. (2015)
NH <sub>3</sub>	0.0638761	kg/FU	Maulini-Duran et al. (2015)

### *Hair waste treatment*

In both composting and SSF, hair waste obtained after the dehairing stage is mixed with raw sludge on a 2:1 ratio (wet weight). The sludge from the tanning wastewater treatment plant is used to inoculate the main substrate and to start up the process (Barrena et al., 2007b). Bulking agent is mixed in a 1:1 ratio (v/v) (Ruggieri et al., 2009).

### *Composting process*

Two technologies for composting of the hair wastes are included in this study: windrow and in-vessel composting. In this study, it is considered that SSF would be performed in an in-vessel system as described later. The input variables for the composting process for both technologies are obtained from Colón et al. (2012).

### *Solid state fermentation process (SSF)*



SSF was carried out in pilot-scale reactors (10-50 L) to obtain all the data necessary to carry out this LCA. The complete description of SSF can be found elsewhere, including operational conditions, material conditioning, final product, etc. (Abraham et al., 2014; Abu Yazid et al., 2016).

The extraction of enzymes takes place within the same vessel that is used for the in-vessel composting. The extraction procedure, as applied in the laboratory, is: the entire mixture is submerged in 50 mM HCl-Tris buffer (pH 8.10) at 1:1 (v/v) ratio (Abu Yazid et al., 2016). Then, the enzyme extract is cleaned through filtration. The remaining solid material after protease extraction can be easily further stabilized to obtain a stable compost-like material with a microbial dynamic respiration index lower than  $1 \text{ g O}_2 \text{ kg}^{-1} \text{ OM h}^{-1}$ , as was demonstrated by Abu Yazid (2016). This is a respiration index typical of stable substrates that can be achieved with traditional composting as well.

It is considered here that 95% of the total environmental impacts of the process will be allocated to SSF and the remaining 5% to compost production. This allocation is based on the economic values of those two products, since the compost derived from hair wastes usually has usually no economic value. On the other hand, the extracted enzymes have a rather significant market value. For example, the commercial value in Spain (Sigma-Aldrich) is €98 per 50 ml of enzyme extract using as reference the protease obtained from *Aspergillus oryzae*. The main inputs to the LCA model are expressed per functional unit (FU), which is 100 kg of raw leather. These are: buffer 80 L/FU (Abu Yazid et al., 2016), energy for filtration 3 kWh/FU (experimental value) and enzyme extract 80 L/FU (Abu Yazid et al., 2016).

## **Results and discussion**

Enzyme production by SSF has been evaluated and is shown in Figure 2. The other scenarios result in similar figures (data not shown). The environmental impacts due to direct emissions are those associated to composting process or SSF process per se. The environmental impacts due to indirect emissions are, for example, those that are generated during the production of hair waste or the

electricity consumption needed to put operate the processes. LCAs to analyse composting (with different methods or wastes) have been extensively presented in the literature (Andersen et al., 2010; Rajcoomar and Ramjeawon, 2016) but, to our knowledge, this is the first time that LCA is applied to SSF processes.

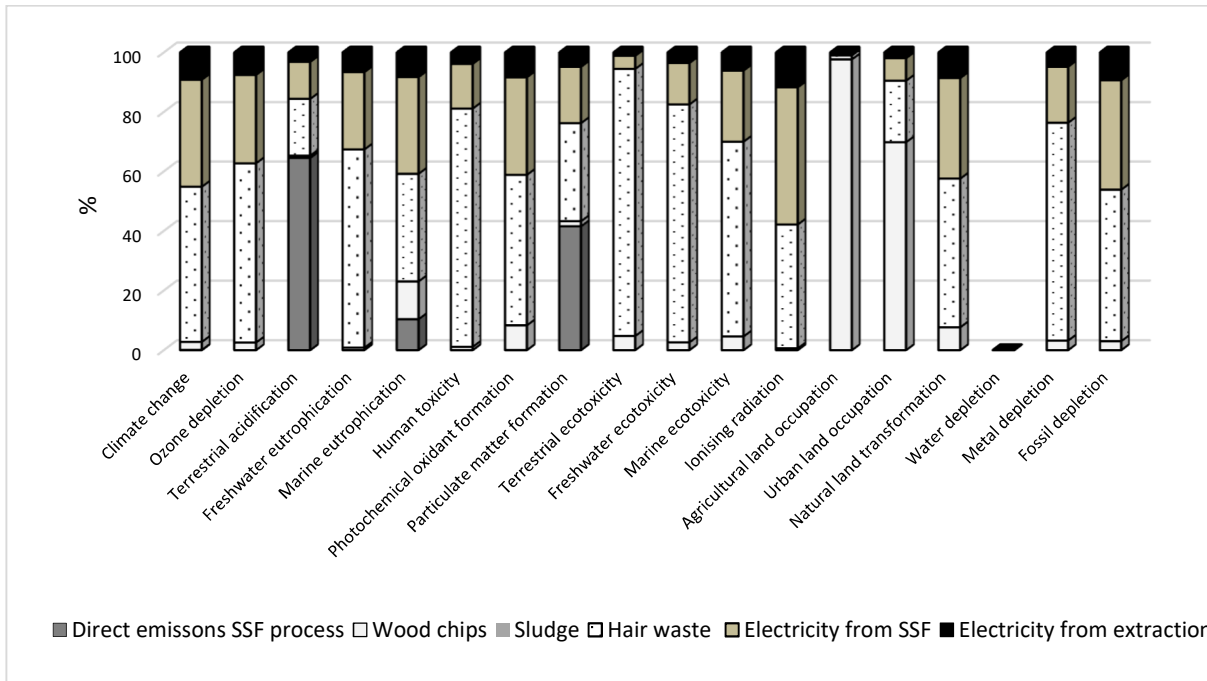

**FIGURE 2:** LCA results for enzyme production by SSF process. Results are expressed as percentage. Impact categories are based on the ReCipe method with 18 midpoint indicators.

The main impacts caused by the direct emissions during extraction of enzymes in SSF are terrestrial acidification and particulate matter (PM) formation. The main emissions responsible for these impacts is the NO<sub>x</sub>, SO<sub>x</sub> and PM generated during the operation of the windrow turned composting equipment and other vehicles operating during windrow turned and in-vessel composting. The Acidification Potential (AP) describes the fate and disposal of acidifying substances, and it is expressed in kg SO<sub>2</sub> equivalents/kg emission (PRé Consultants, 2015).

In Figure 2, it is clearly shown that most of the impacts are due to indirect emissions. The impact categories of fresh water aquatic ecotoxicity, marine aquatic ecotoxicity, fresh water eutrophication, metal depletion and natural land transformation were relatively high. Another high

indirect impact comes from the electricity used in the SSF process. This production has high impacts on ionising radiation or climate change categories due to the material (usually fossil fuel) used for electricity production in Spain.

The environmental impacts associated to each process of hair waste management during leather production are presented in Figure 3. This figure presents the sum of both direct and indirect emissions for both treatment technologies. All the results are shown as normalized values, which permits a direct comparison of the scenarios.

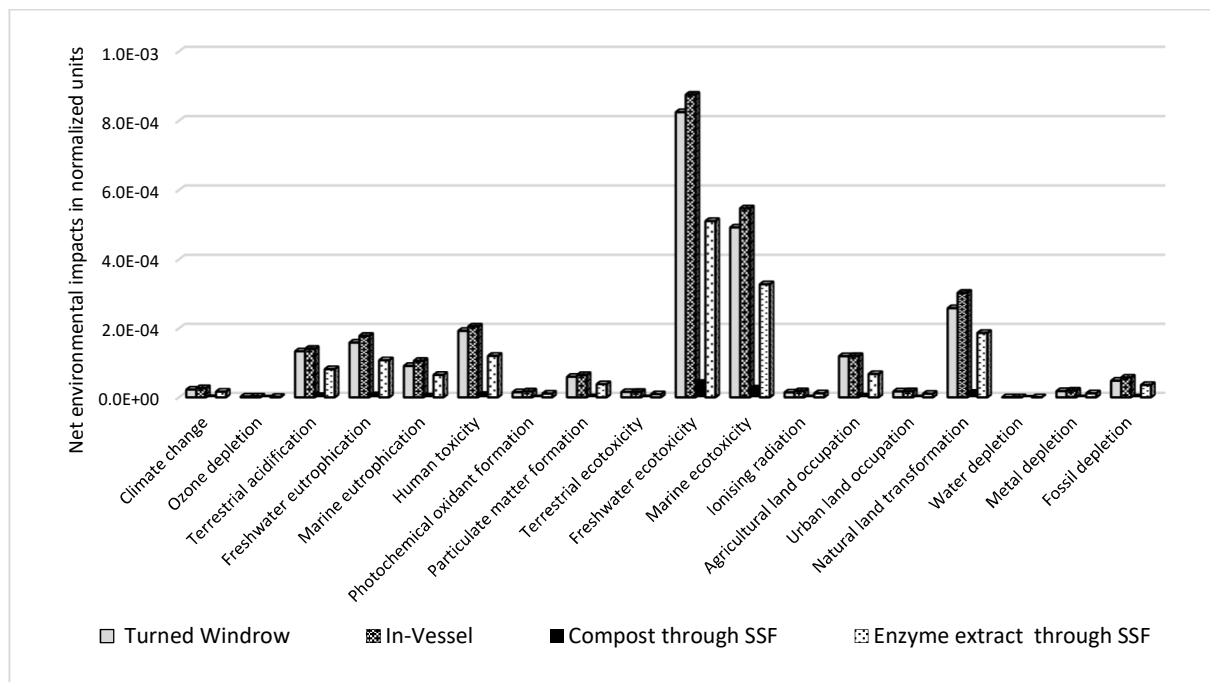

**FIGURE 3:** LCA results to compare different stages of the processes. Results are normalized. Impact categories were based on the ReCiPe method with 18 midpoint indicators.

Figure 3 shows the comparison of the composting processes (by turned windrow and in-vessel systems) with the SSF process. It presents the total emissions, i.e. the sum of direct and indirect environmental impacts per category and per scenario. According to Figure 3, the high environmental impacts attributed to freshwater ecotoxicity, marine ecotoxicity and natural land transformation are observed. This was expected, due to the indirect environmental impacts associated with hair waste production, which involves the use of chemicals that consume water and

electricity and therefore result in the consumption of fossil fuels and the emission of gases such as CO<sub>2</sub>, NO<sub>x</sub> and SO<sub>x</sub>. Actually, in all the scenarios, the environmental impact categories with the highest values were the same. It is clear that the use of in-vessel system in composting leads to higher environmental impacts due to the indirect emissions associated to the higher energy consumption.

Regarding the SSF process, the same relative profile of the environmental impacts as in composting is observed. However, the SSF process has lower overall environmental impacts due to the replacement of chemicals by the enzymes, obtained in SSF, and thereof due to the reduction of the indirect emissions associated with the production of those chemicals. In all categories, the stage of enzyme extraction has a high contribution in the overall impacts due to the energy requirements of the in-vessel system where the extraction takes place.

## **Conclusions**

The LCA results show that:

- 1) Applying SSF to treat the hair waste generated in a leather industry leads to lower environmental impacts compared to traditional composting in all impact categories.
- 2) The relative magnitude of the environmental impacts in both scenarios is the same, with fresh water ecotoxicity and marine ecotoxicity being the major environmental impacts in both. This is mainly attributed to electricity consumption. Ozone depletion, photochemical oxidant formation, terrestrial ecotoxicity, ionising radiation, urban land occupation and water depletion are negligible.
- 3) The direct emissions in both scenarios contribute to three impact categories: terrestrial acidification (64%), marine eutrophication (10%) and particulate matter formation (41%). There is no influence on the other 15 categories.
- 4) Anyway, it is important to highlight the limitation of this study, which does not consider the application of compost and enzyme within the boundaries of LCA, as this was beyond the scope of

this paper. Our study mainly deals with the environmental impacts related to hair waste treatment by two different technologies as a first step of its management. Further research should be focused on completing LCA including the other steps of the management of both processes.

Consequently, in absolute terms of the environmental impact assessment, the SSF process for the management of solid waste allows to obtain a bio-product with added value (enzyme), decreases the amount of solid waste and minimizes the consumption of resources. This validates the SSF alternative approach as an alternative method for the management of hair waste under the framework of circular economy.

### **Acknowledgements**

E. Catalán thanks the financial support provided by the *Universitat Autònoma de Barcelona* for a pre-doctoral grant and all the authors thank the Spanish Ministerio de Economía y Competitividad (Project CTM2015-69513R) and Mr. Miquel Vila from the Leather Tanner's Union in Igualada, for providing the detailed information for this study. Dimitrios Komilis thanks Tecniospring for the financial support (project no. TECSPR13-1-0006, ACCIÓ, Government of Catalonia).

### **REFERENCES**

- Abraham J, Gea T, Sánchez A, (2014). Substitution of chemical dehairing by proteases form solid-state fermentation of hair waste. *Journal of Cleaner Production* 74:191-198.
- Abu Yazid N, Barrena R, Sánchez A, (2016). Assessment of protease activity in hydrolysed extracts from SSF of hair waste by and indigenous consortium of microorganisms. *Waste Management* 49:420-426.
- Andersen JK, Boldrin A, Christensen TH, Scheutz C, (2010). Mass balances and life-cycle inventory for a garden waste windrow composting plant (Aarhus, Denmark). *Waste Management and Research* 28:1010-1020.

- Barrena R, Pagans E, Vázquez F, Artola A, Sánchez A, (2007a). Full-Scale Co-Composting of Hair Wastes from the Leather Manufacturing Industry and Sewage Sludge. *Compost Science and Utilization* 15:16-21.
- Barrena R, Pagans E, Artola A, Vazquez F, Sánchez A, (2007b). Co-composting of waste from tanning industry with de-inking and municipal wastewater sludges. *Biodegradation* 18:257-268.
- Bisen PS, Sharma A, (2014) Introduction to Instrumentation in Life Sciences. *CRC Press, Taylor & Francis Group*, New York.
- Chowdhury M, Mostafa Biswas TK, Saha AK, (2013). Treatment of leather industrial effluents by filtration and coagulation processes. *Water Resources and Industry* 3:11-22.
- Chowdhury M, Mostafa, MG, Kumar T, Mandal A, Kumar A, (2015). Characterization of the effluents from leather processing industries. *Environmental Process* 2:173-187.
- Colón J, Cadena E, Pognani M, Barrena R, Sánchez A, Font A, (2012). Determination of the energy and environmental burdens associated with the biological treatment of source-separated Municipal Solid Waste. *Energy & Environmental Science* 5:5731-5741.
- Dawber R, (1996). Hair: its structure and response to cosmetics preparations. *Clinics Dermatology* 14:105-112.
- Guo M, Murphy R.J, (2012). LCA data quality: sensitivity and uncertainty analysis. *The Science of Total Environment* 435-436:230-243.
- Maulini-Duran C, Artola A, Font X, Sánchez A, (2015). A systematic study of the gaseous emissions from biosolids composting: Raw sludge versus anaerobically digested sludge. *Bioresource Technology* 143:43-51.
- PRé Consultants, (2015). SimaPro Database Manual. Methods library. *PRé-Sustainability, The Netherlands*.
- Rajcoomar A, Ramjeawon T, (2016). Life cycle assessment of municipal solid waste management scenarios on the small island of Mauritius. *Waste Management and Research*, available online: DOI: 10.1177/0734242X16679883.
- Renge VC, Khedkar SV, Nandurkar NR, (2012) Enzyme synthesis by fermentation method: a review. *Scientific Reviews & Chemical Communications* 2:585-590.
- Ruggieri L, Gea T, Artola A, Sánchez A, (2009). Air filled porosity measurements by air pycnometry in the composting process: a review and a correlation analysis. *Bioresource Technology* 100:2655-2666.

Singhania R, Patel A., Soccol C, Pandey A, (2009). Recent advances in solid-state fermentation.

*Biochemical Engineering Journal*, 44, 13-18.