



US010160555B2

(12) **United States Patent**
Turse et al.

(10) **Patent No.:** **US 10,160,555 B2**
(45) **Date of Patent:** **Dec. 25, 2018**

(54) **MULTIPLE BOOM DEPLOYMENT**

(71) Applicant: **Composite Technology Development, Inc.**, Lafayette, CO (US)

(72) Inventors: **Dana Turse**, Broomfield, CO (US);
Larry Adams, Thornton, CO (US);
Doug Richardson, Westminster, CO (US)

(73) Assignee: **COMPOSITE TECHNOLOGY DEVELOPMENT, INC.**, Lafayette, CO (US)

(*) Notice: Subject to any disclaimer, the term of this patent is extended or adjusted under 35 U.S.C. 154(b) by 354 days.

(21) Appl. No.: **15/136,487**

(22) Filed: **Apr. 22, 2016**

(65) **Prior Publication Data**

US 2016/0311558 A1 Oct. 27, 2016

Related U.S. Application Data

(60) Provisional application No. 62/150,965, filed on Apr. 22, 2015.

(51) **Int. Cl.**

B64G 1/22 (2006.01)
B64G 1/66 (2006.01)
B64G 1/34 (2006.01)
B64G 1/40 (2006.01)
B64G 1/44 (2006.01)

(52) **U.S. Cl.**

CPC **B64G 1/22** (2013.01); **B64G 1/34** (2013.01); **B64G 1/407** (2013.01); **B64G 1/44** (2013.01); **B64G 1/66** (2013.01)

(58) **Field of Classification Search**

CPC B64G 1/222; B64G 1/34; B64G 1/407; B64G 1/44; B64G 1/66

See application file for complete search history.

(56) **References Cited**

U.S. PATENT DOCUMENTS

3,144,104 A * 8/1964 Weir E04C 3/005
182/41
3,300,910 A * 1/1967 Isaac B64C 27/50
137/355.26
3,387,414 A * 6/1968 Adams E04C 3/005
206/216
3,499,610 A * 3/1970 Hamlin B64G 9/00
138/166
3,508,587 A * 4/1970 Mauch F16L 11/121
138/119

(Continued)

Primary Examiner — Medhat Badawi

(57) **ABSTRACT**

Some embodiments of the invention include a boom deployment system. The boom deployment system, for example, may include a housing, a spool, a first boom, and a second boom. The spool may be disposed within the housing and configured to rotate around an axis that is fixed relative to the housing. The first boom and/or the second boom may have a cylindrical shape in a deployed configuration, a flattened shape in a stowed configuration, and a slit that extends along the longitudinal length of the boom in the deployed configuration. The first boom and/or the second boom may be stowed in the stowed configuration flattened and wrapped around the spool. The first boom and/or the second boom may transition from the stowed configuration to the deployed configuration as the spool rotates around the axis.

12 Claims, 22 Drawing Sheets

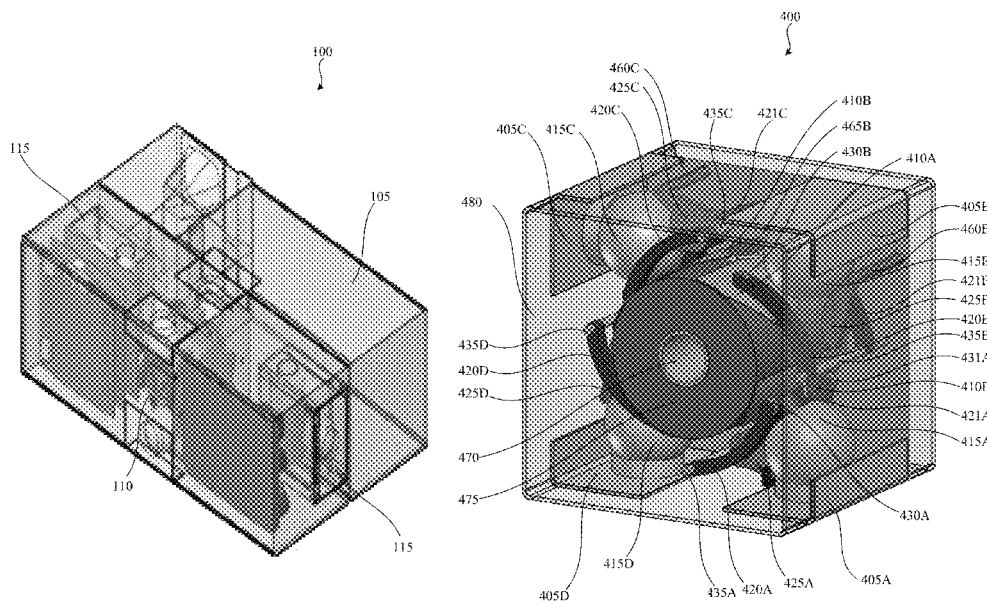

(56)

References Cited

U.S. PATENT DOCUMENTS

3,589,632	A *	6/1971	Rew	B21C 47/003 188/82.84	2010/0187364	A1 *	7/2010	Kutter	B64G 1/1078 244/171.7
3,608,844	A *	9/1971	Tumulty, Jr.	B21C 47/18 242/373	2010/0187365	A1 *	7/2010	Kutter	B64G 1/1078 244/171.7
3,735,943	A *	5/1973	Fayet	B64G 1/222 136/245	2011/0204186	A1 *	8/2011	Keller	B64G 1/222 244/172.6
4,018,397	A *	4/1977	Rusch	B21C 37/10 242/388.6	2011/0210209	A1 *	9/2011	Taylor	B64G 1/222 244/172.6
4,225,871	A *	9/1980	Ramari	H01Q 1/087 343/877	2012/0012154	A1 *	1/2012	Keller	B64G 1/222 136/245
4,265,690	A *	5/1981	Lowenhar	H01P 3/00 156/148	2012/0090660	A1 *	4/2012	Keller	B64G 1/222 136/245
4,991,784	A *	2/1991	Schmid	B64G 9/00 242/390.3	2013/0061541	A1 *	3/2013	Taylor	B29C 67/0014 52/108
5,235,788	A *	8/1993	Maimets	B64G 4/00 244/172.6	2013/0186011	A1 *	7/2013	Keller	E04H 12/00 52/108
6,217,975	B1 *	4/2001	Daton-Lovett	B29C 61/0608 156/161	2014/0123575	A1 *	5/2014	Bobbio	E04H 12/185 52/108
6,256,938	B1 *	7/2001	Daton-Lovett	F16H 19/064 138/119	2014/0230949	A1 *	8/2014	Daton-Lovett	B64G 1/222 138/177
6,343,442	B1 *	2/2002	Marks	B64G 1/222 244/172.6	2015/0144740	A1 *	5/2015	Turse	B64G 1/44 244/172.6
6,508,036	B1 *	1/2003	Cadogan	B64G 1/222 52/108	2015/0259911	A1 *	9/2015	Freebury	E04O 3/005 52/108
7,806,370	B2 *	10/2010	Beidleman	B64G 1/222 136/245	2015/0284955	A1 *	10/2015	Adams	E04O 3/005 52/108
8,683,755	B1 *	4/2014	Spence	B64G 1/222 136/245	2015/0368903	A1 *	12/2015	Turse	B65H 75/4402 242/407
8,893,442	B1 *	11/2014	Spence	E04O 3/005 52/108	2016/0032609	A1 *	2/2016	Kucinski	B21C 37/0818 52/108
8,894,017	B1 *	11/2014	Baghdasarian	B64G 1/443 136/245	2016/0137319	A1 *	5/2016	Steele	B64G 1/443 52/745.2
9,156,568	B1 *	10/2015	Spence	B64G 1/44	2016/0332752	A1 *	11/2016	Abrams	B64G 1/222
9,528,264	B2 *	12/2016	Freebury	E04O 3/005	2017/0158357	A1 *	6/2017	Hart, III	B64G 1/222
9,580,190	B1 *	2/2017	Spence	B64G 1/222	2017/0297749	A1 *	10/2017	Steele	B64G 1/44
9,611,056	B1 *	4/2017	Spence	B64G 1/443	2017/0298628	A1 *	10/2017	Rakow	B64G 1/222
						2018/0111703	A1 *	4/2018	Hensley	B64G 1/222

* cited by examiner

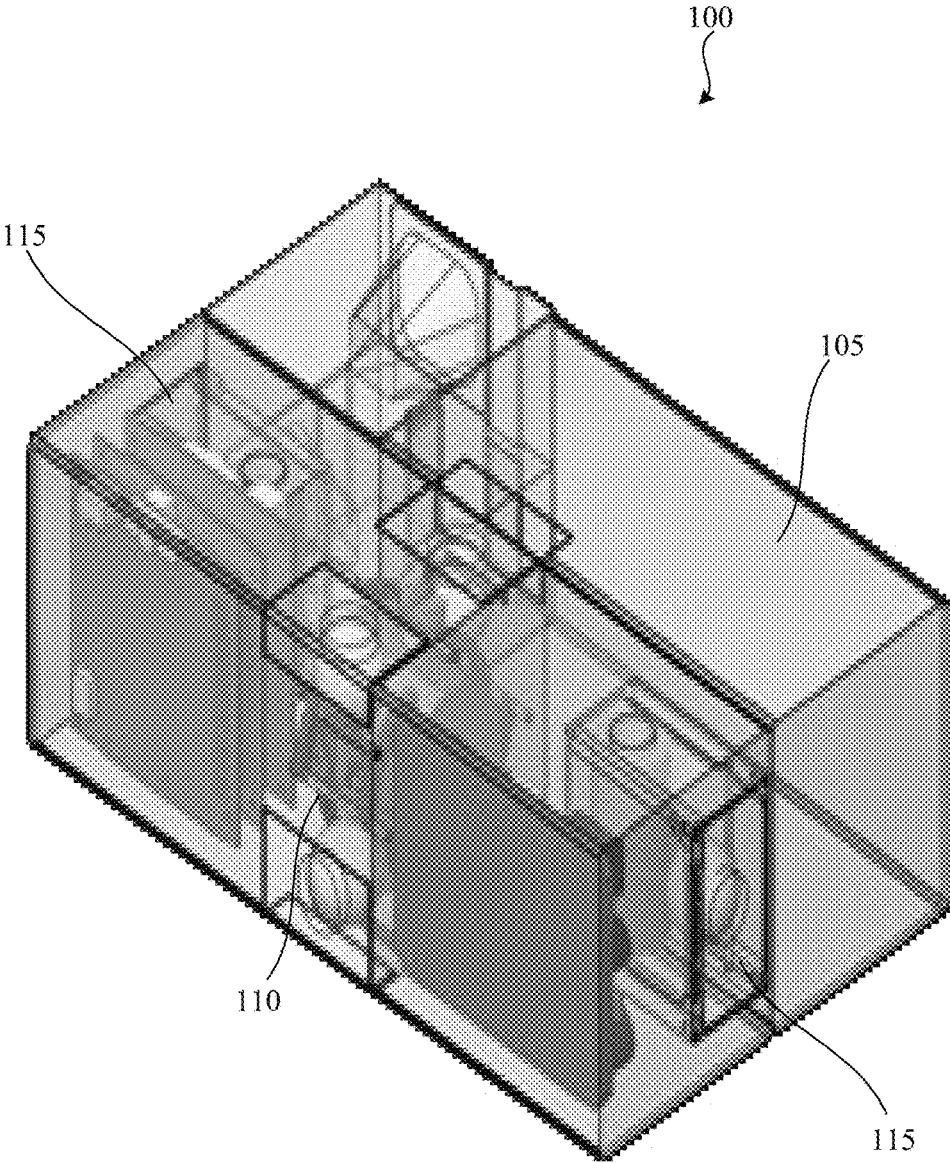

FIG. 1

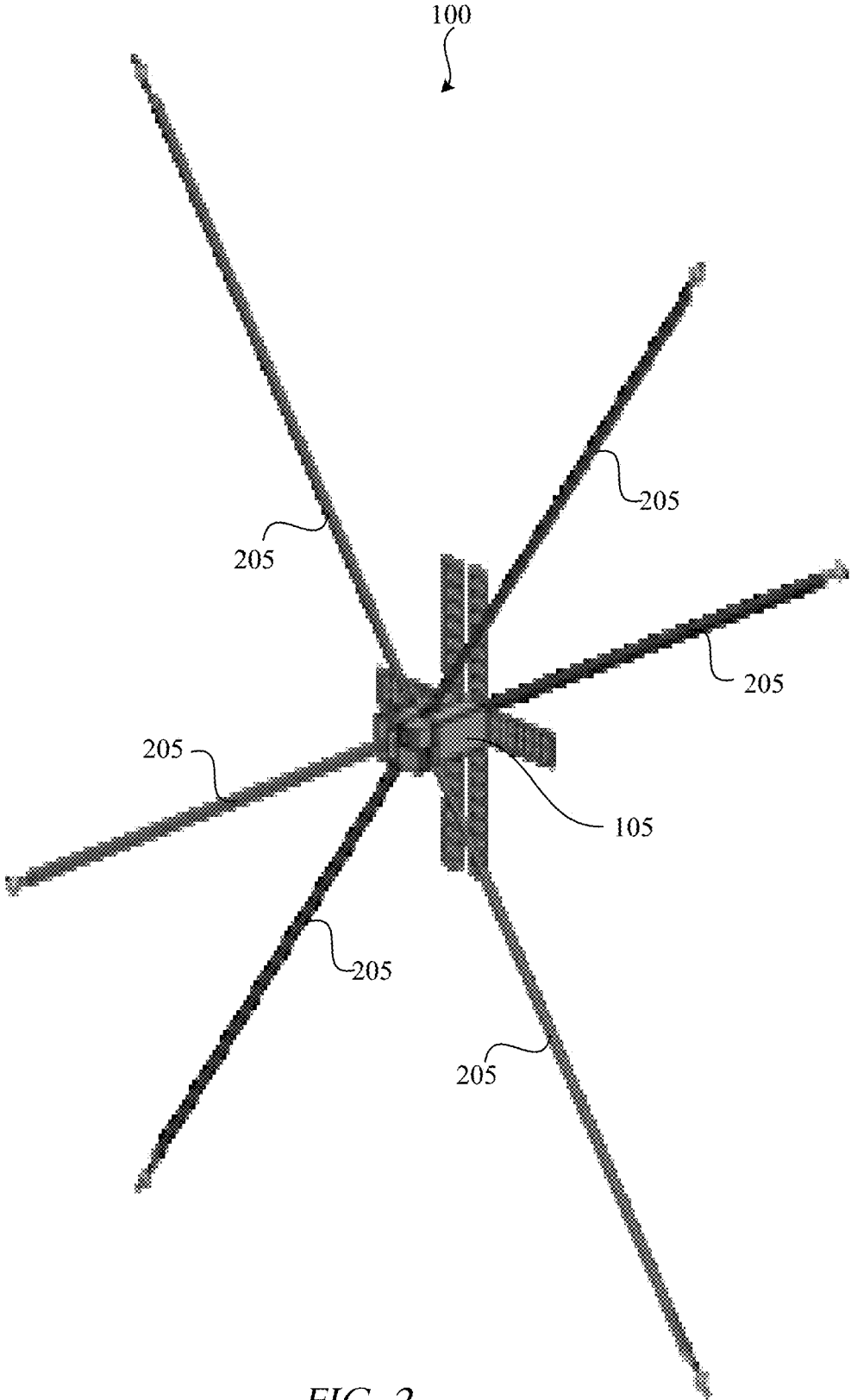

FIG. 2

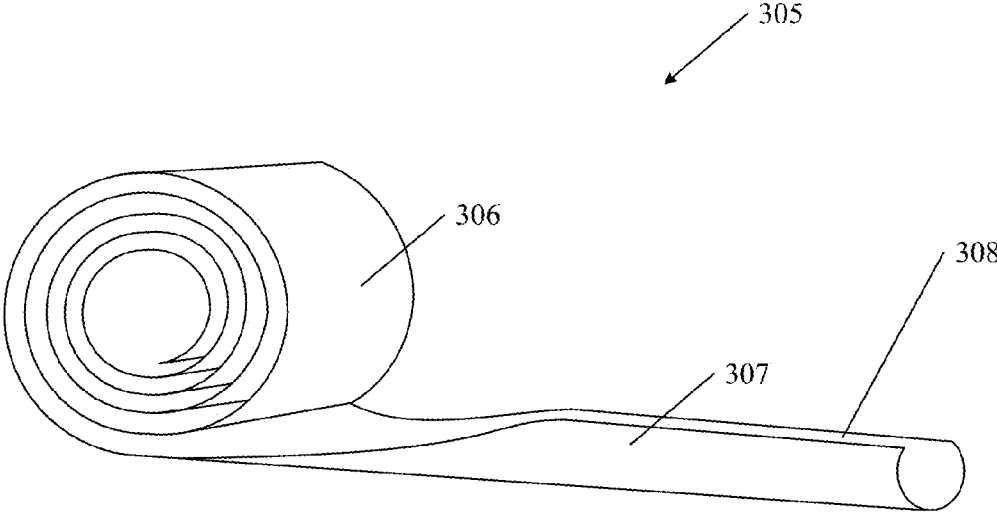

FIG. 3

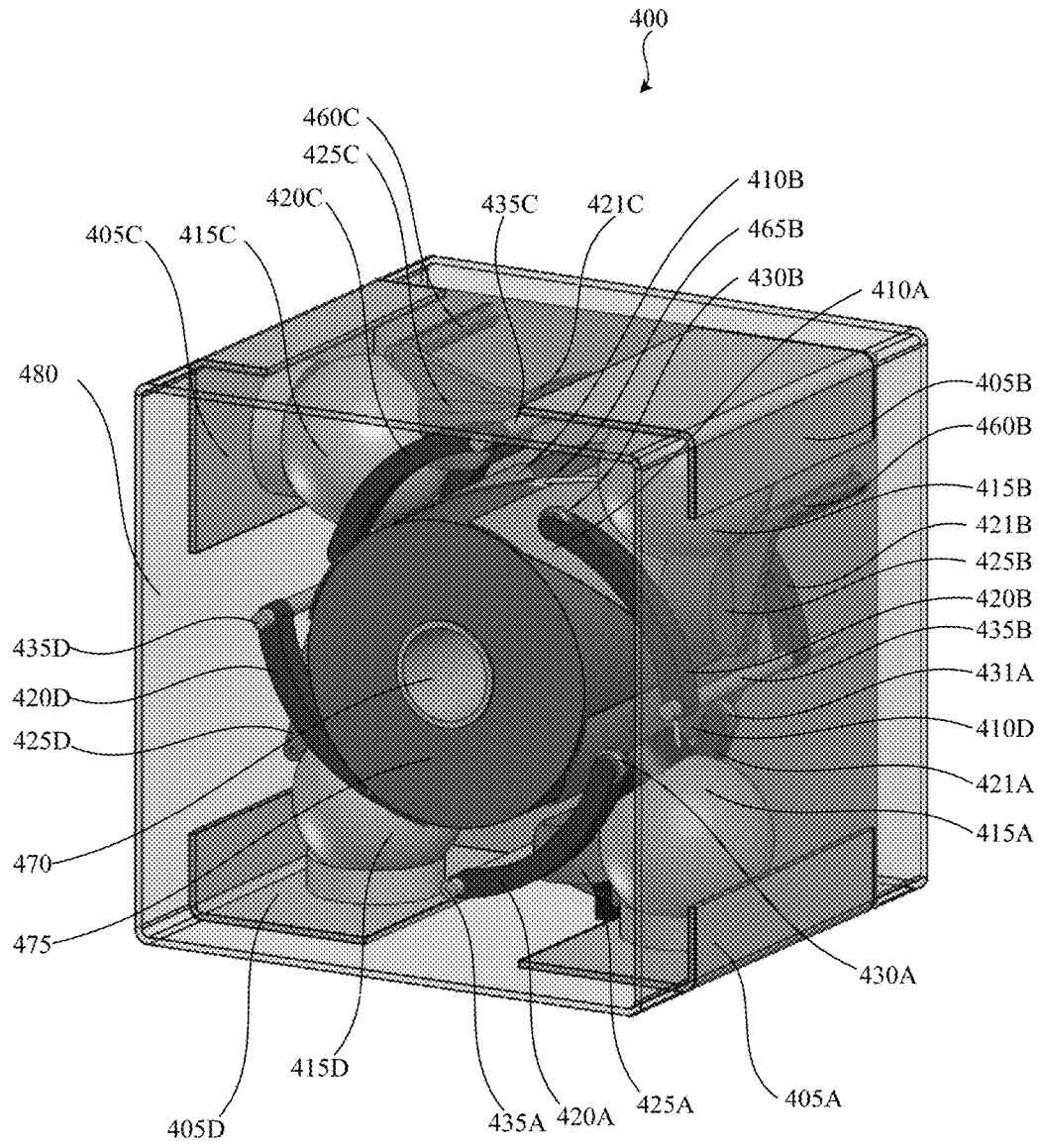

FIG. 4

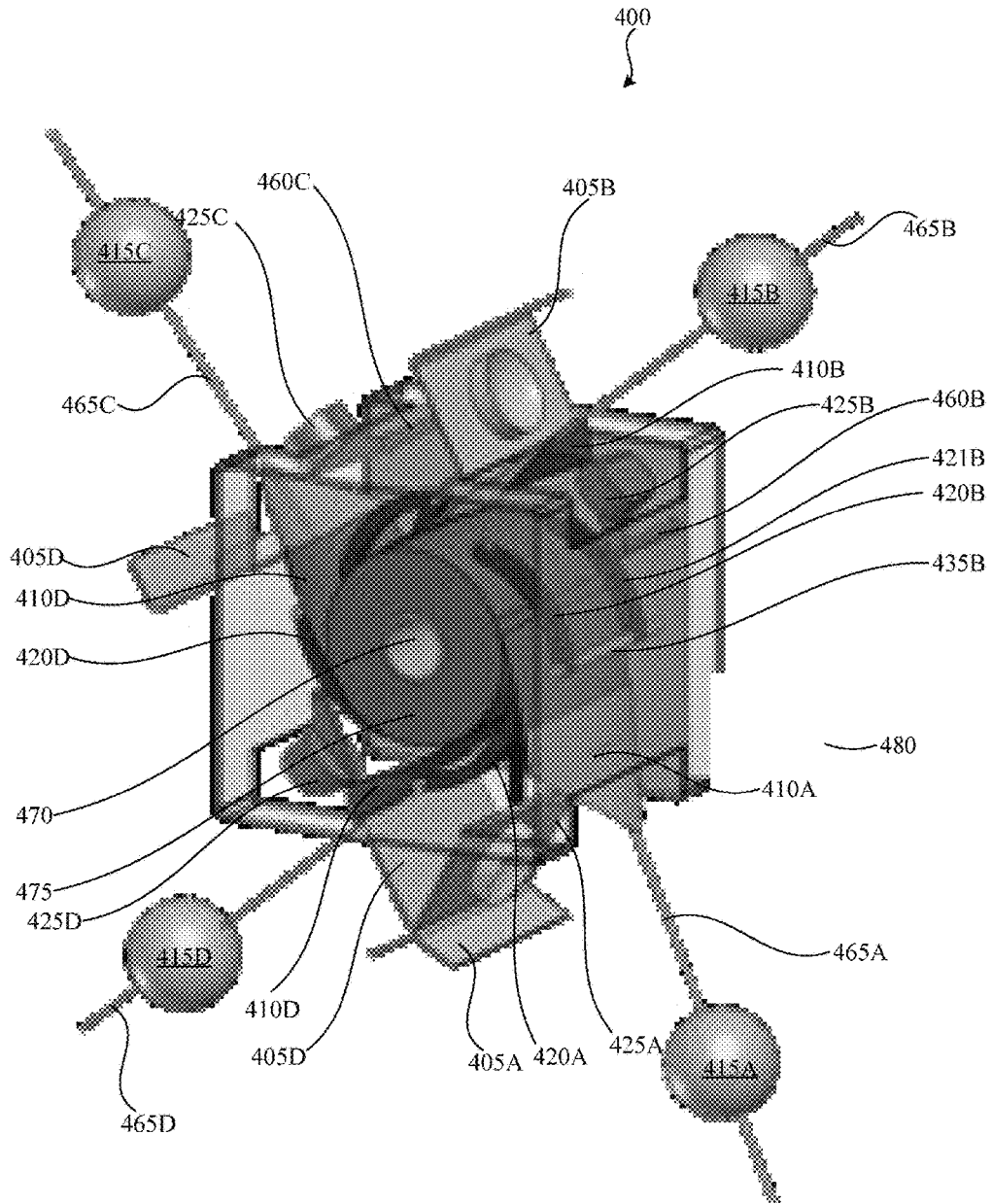

FIG. 5

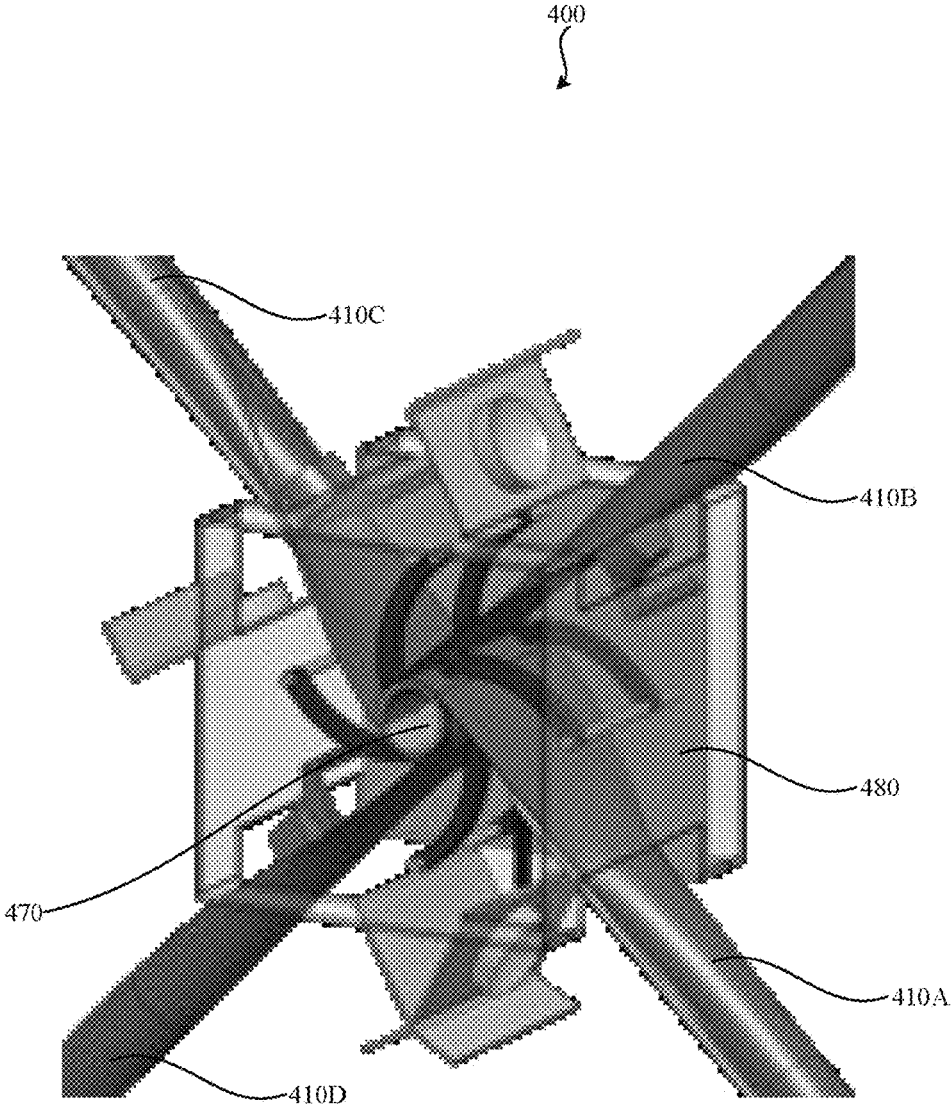

FIG. 6

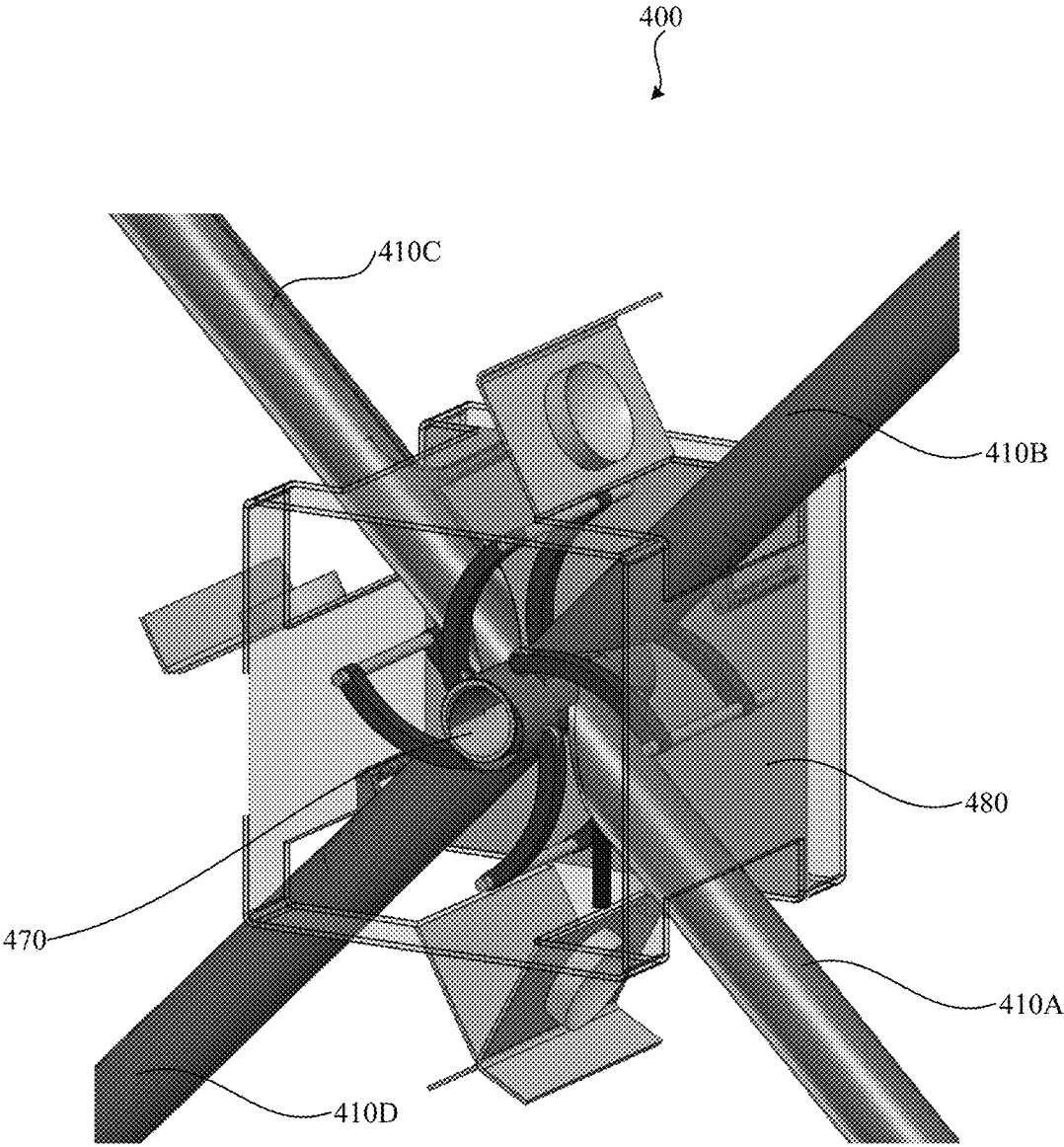

FIG. 7

400

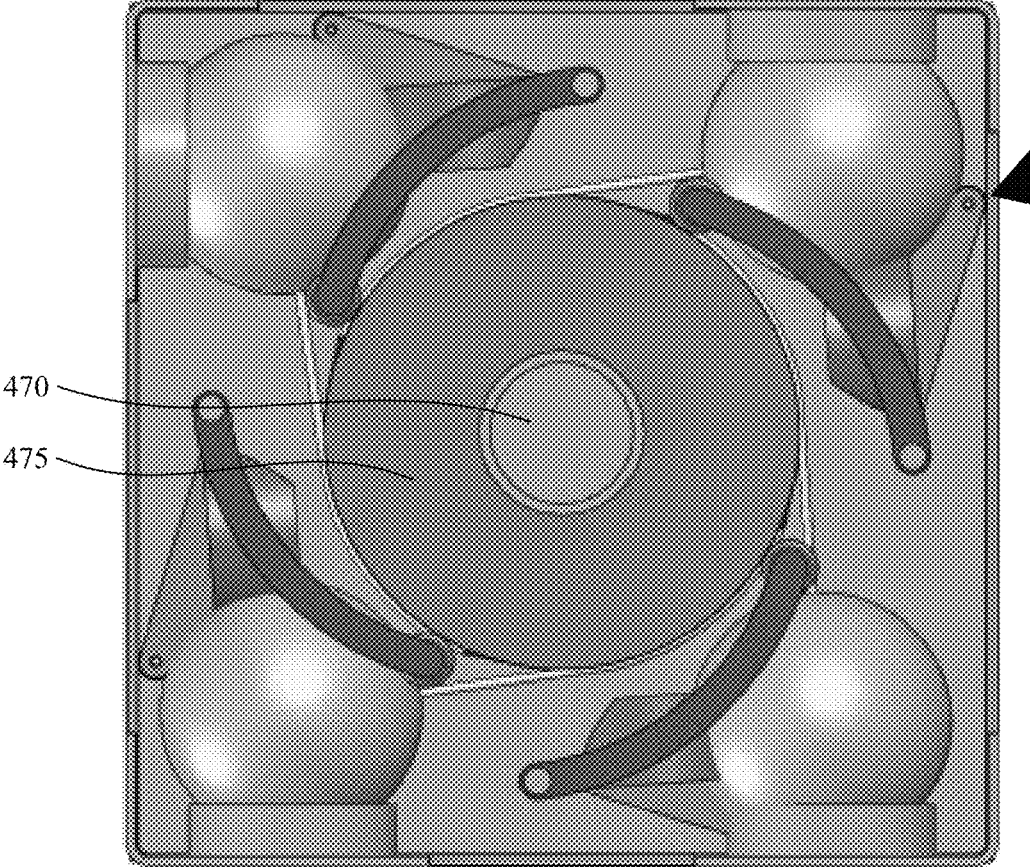

FIG. 8

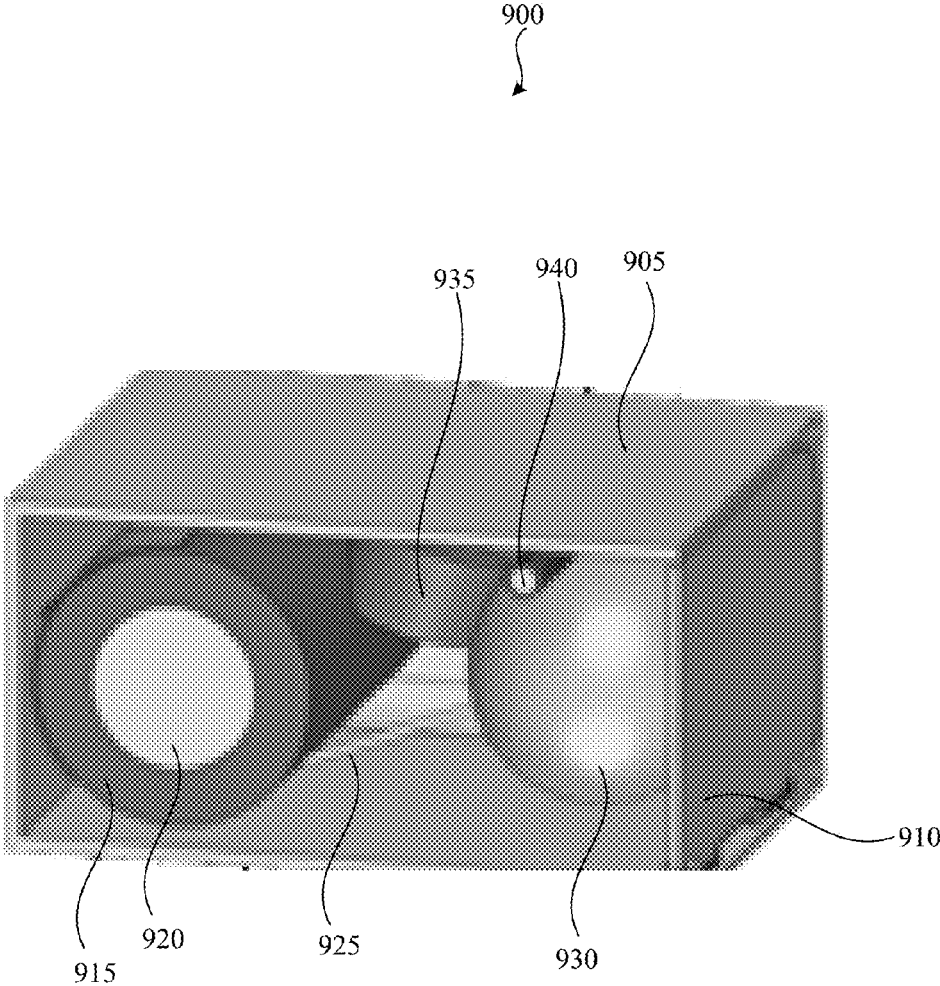

FIG. 9

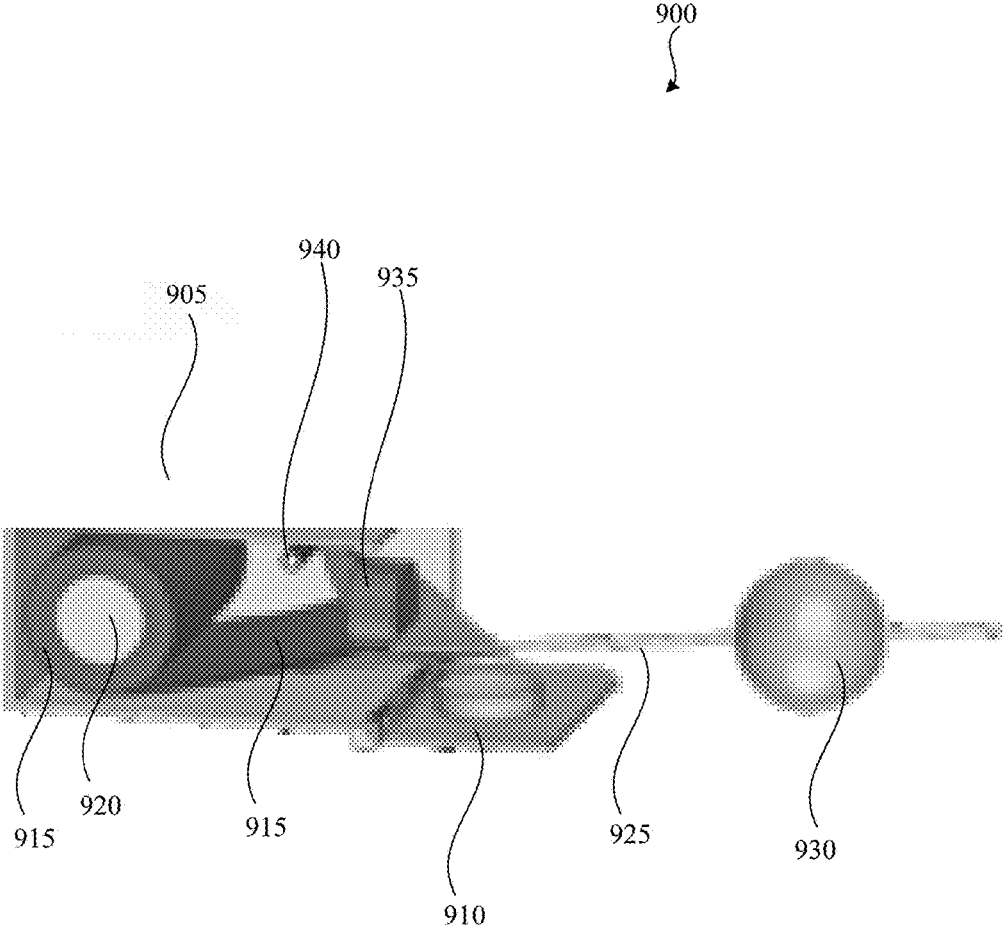

FIG. 10

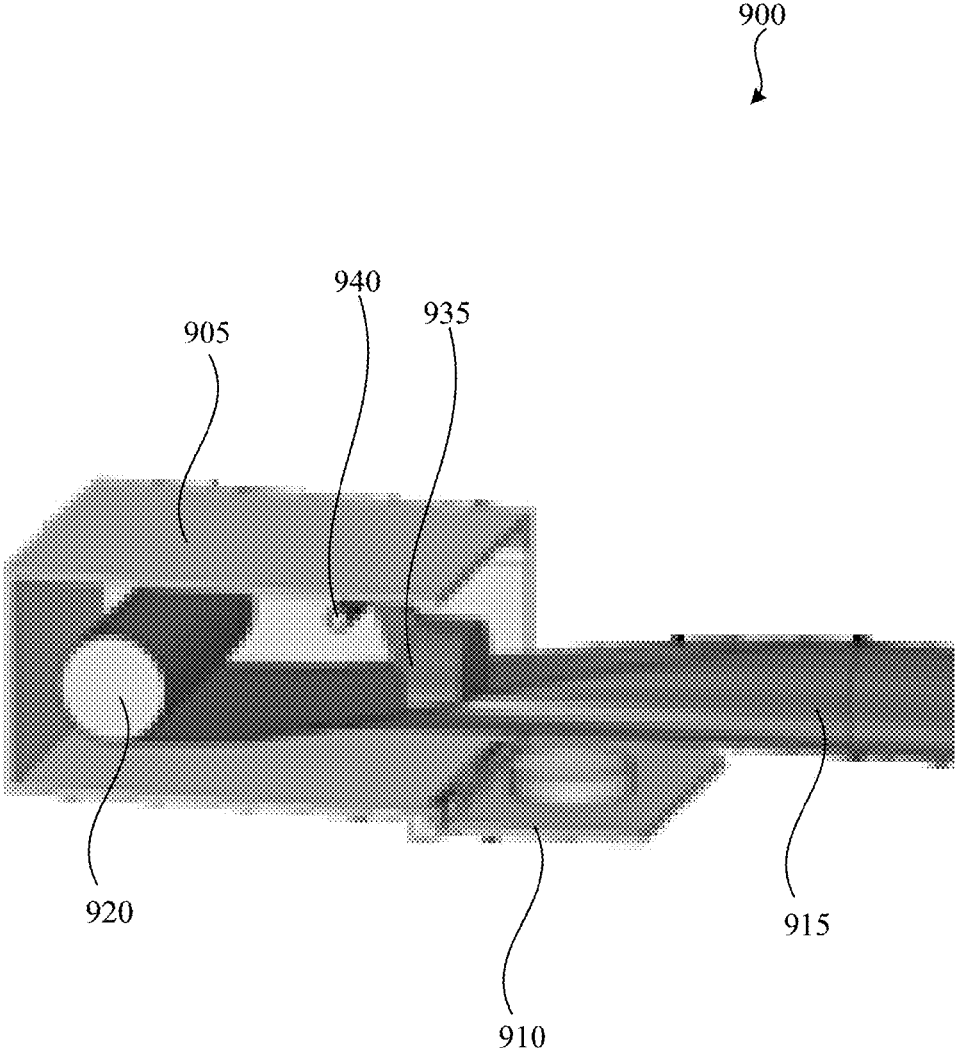

FIG. 11

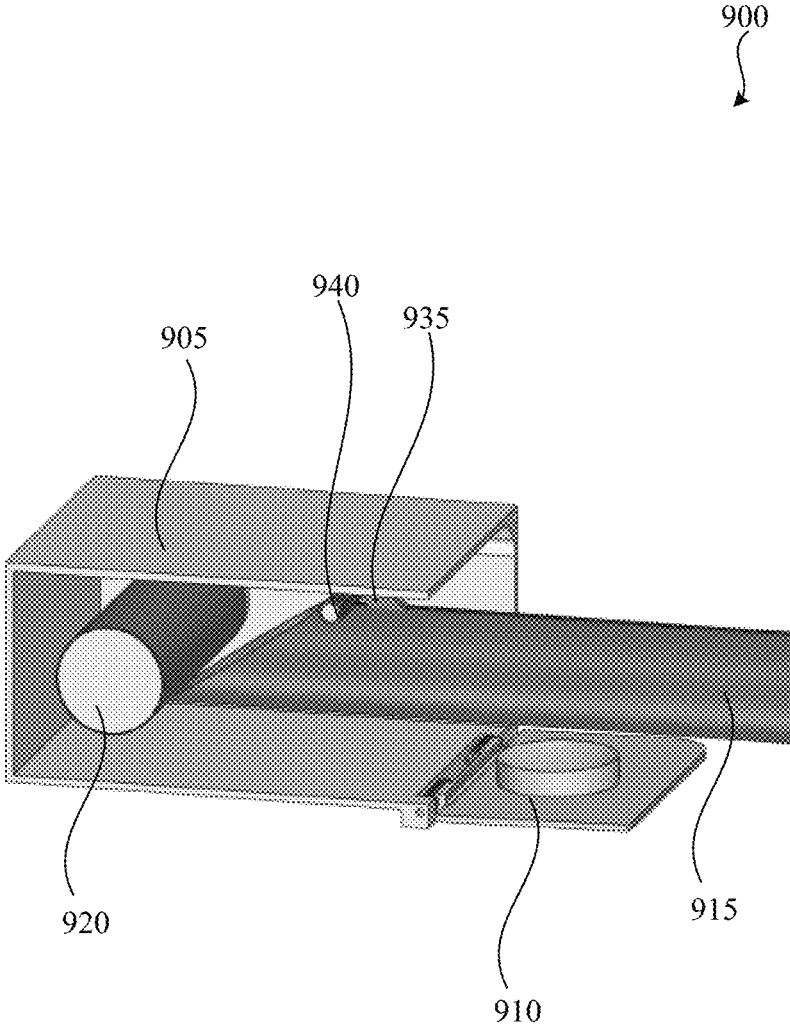

FIG. 12

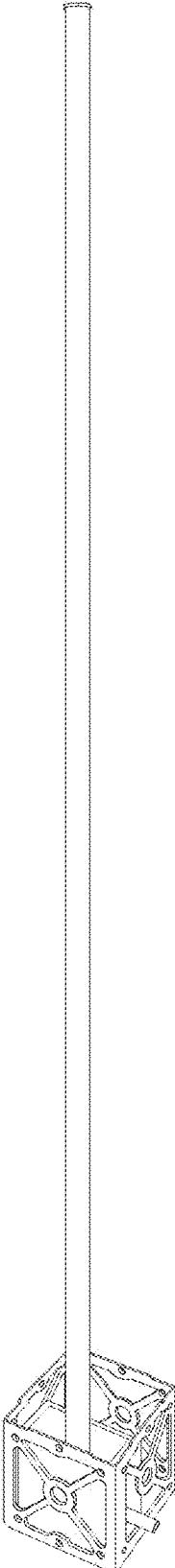

FIG. 13A

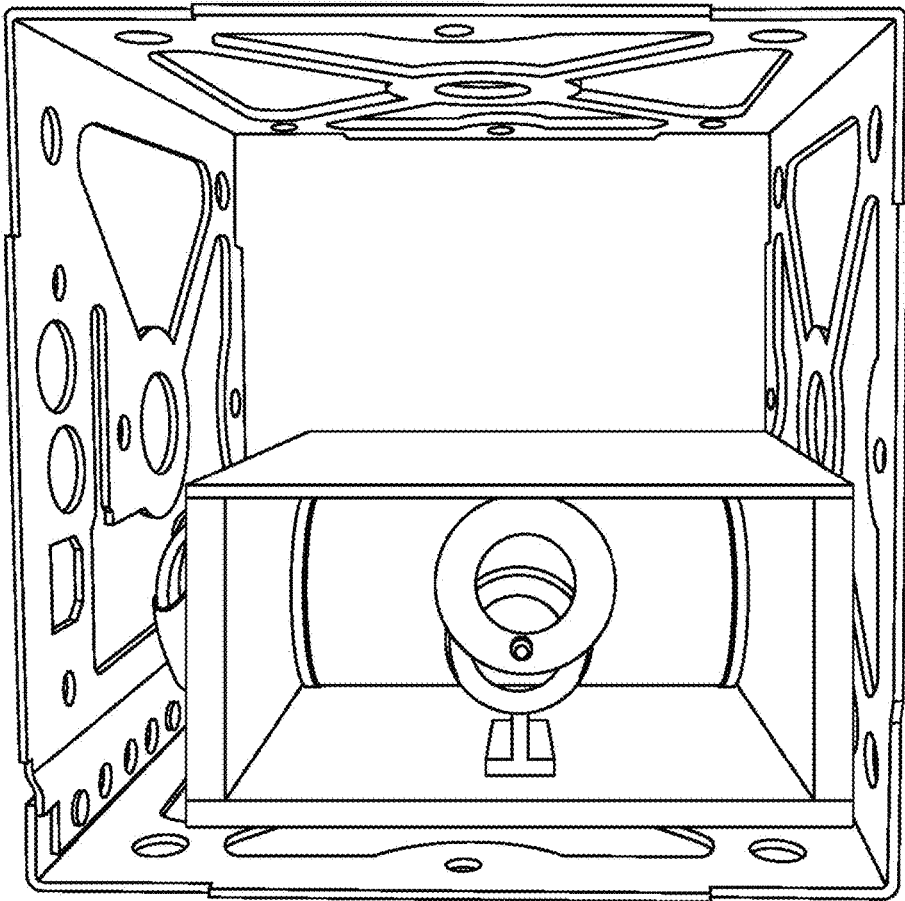

FIG. 13B

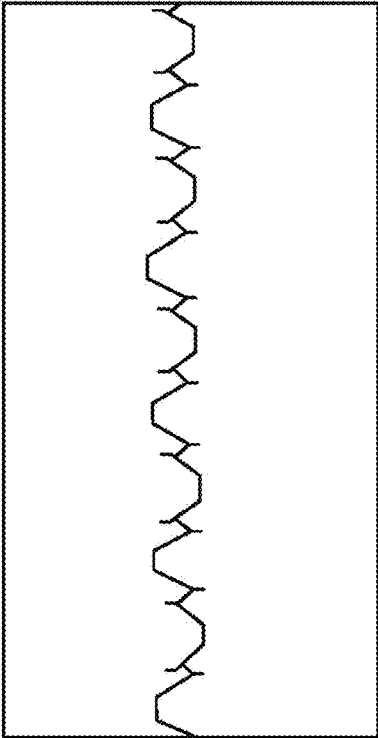

FIG. 14B

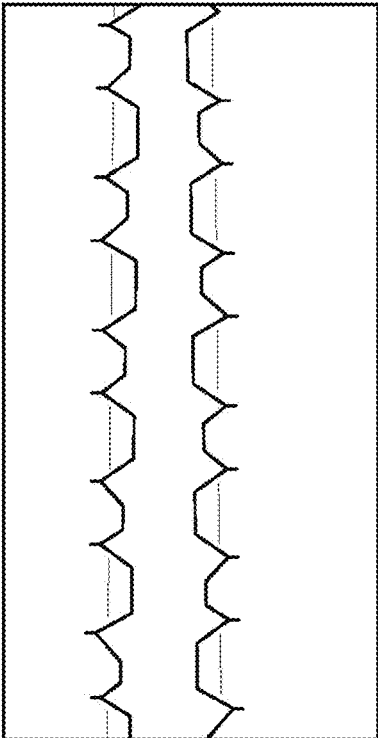

FIG. 14A

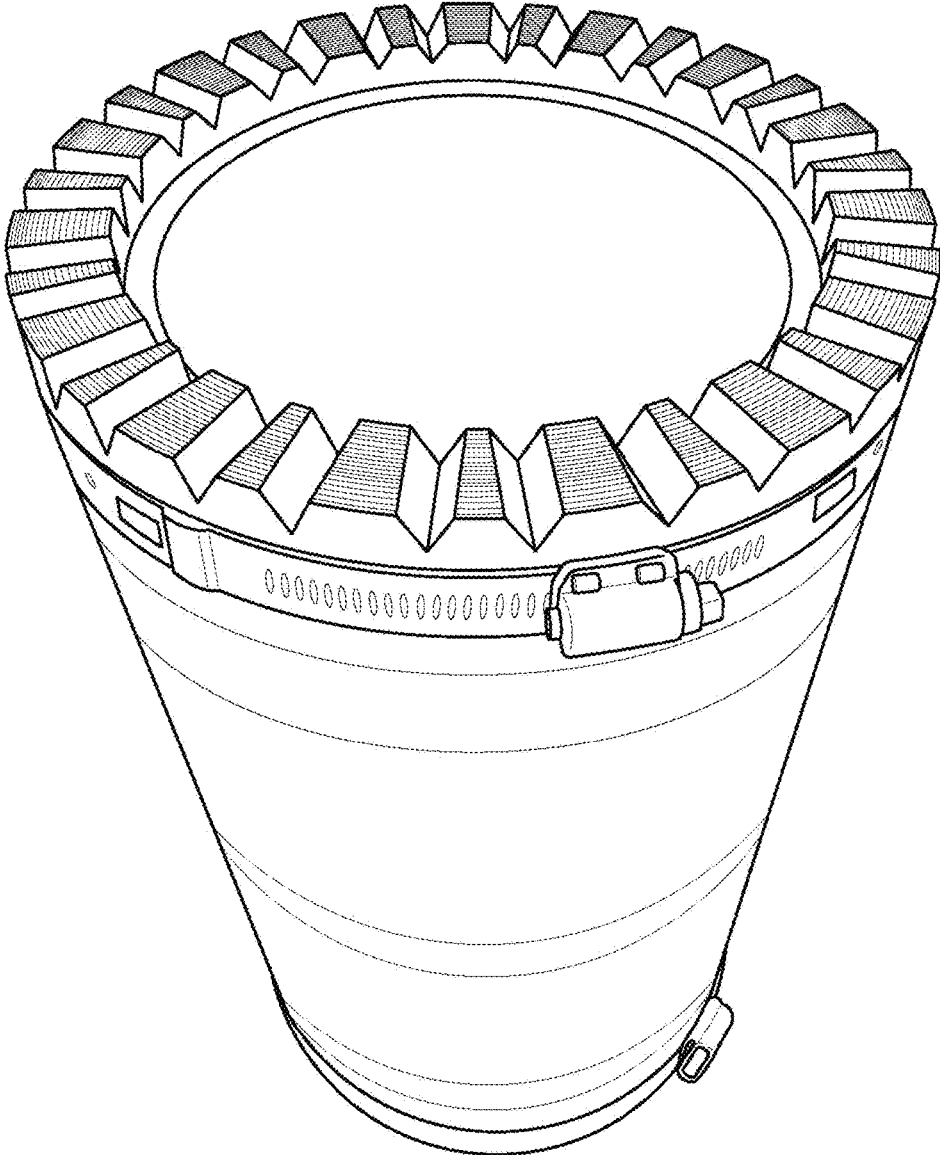

FIG. 15A

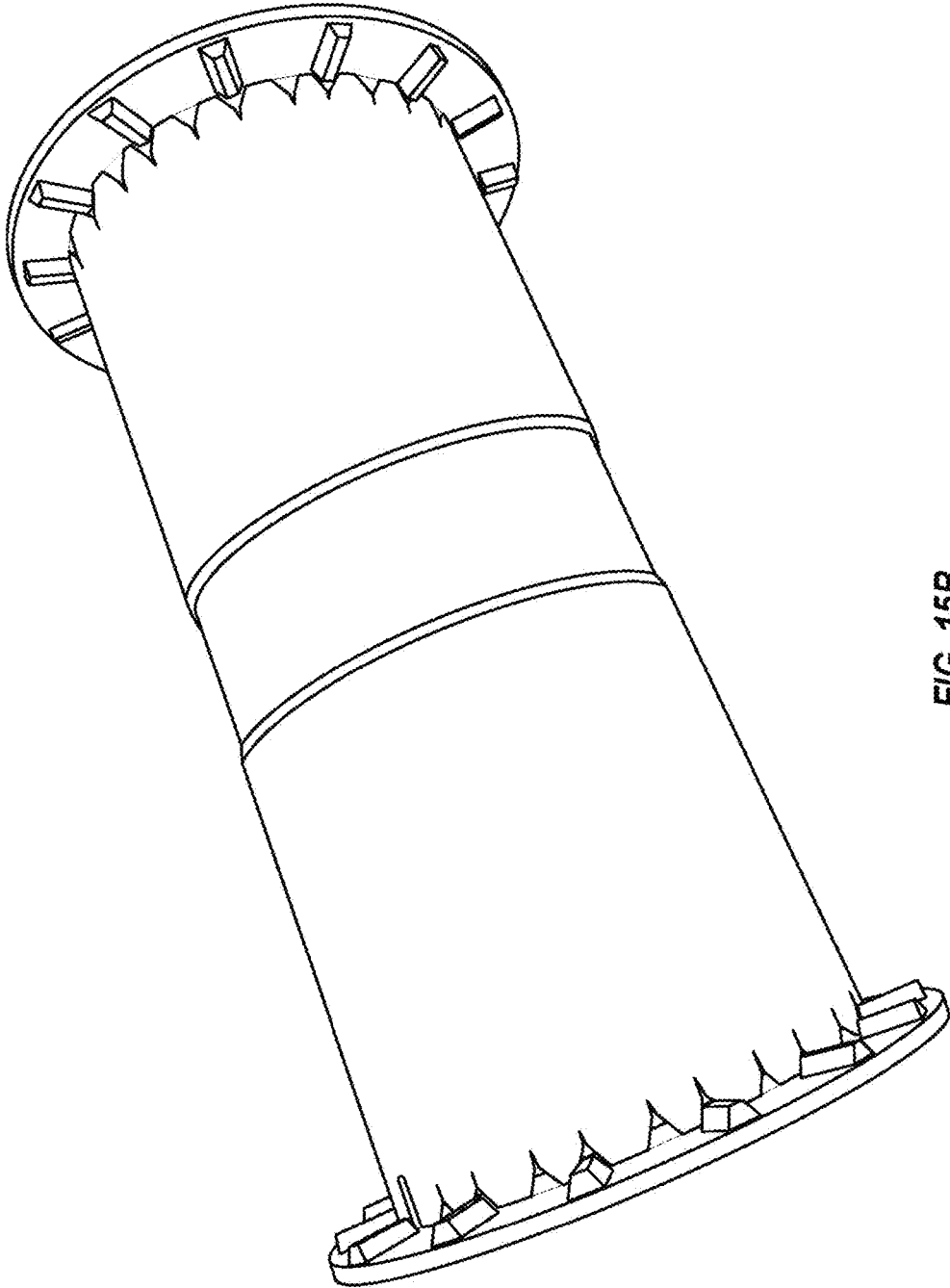

FIG. 15B

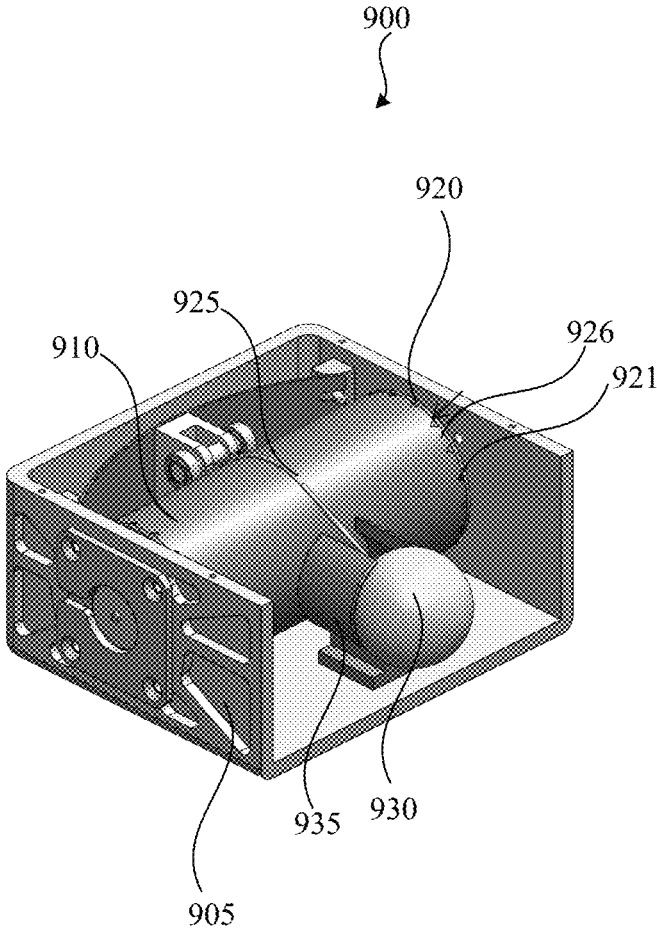
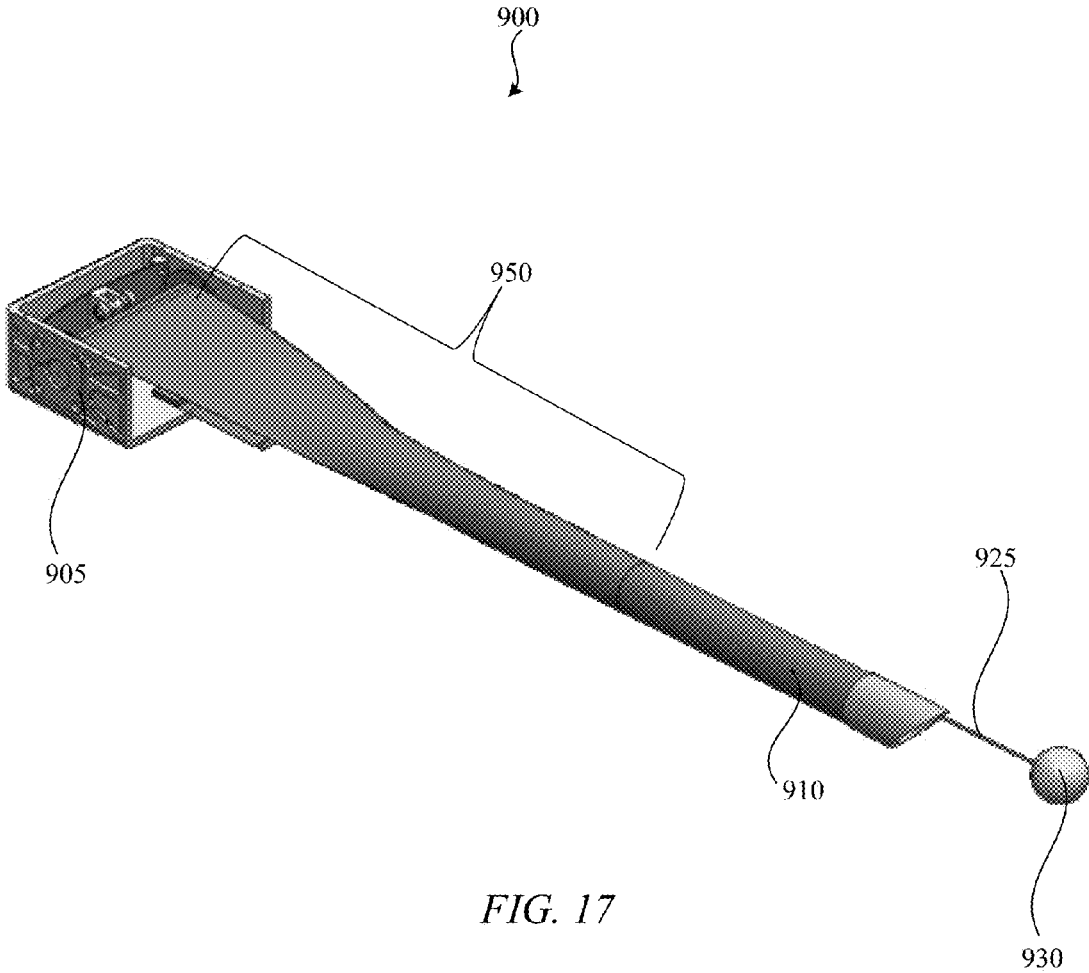

FIG. 16



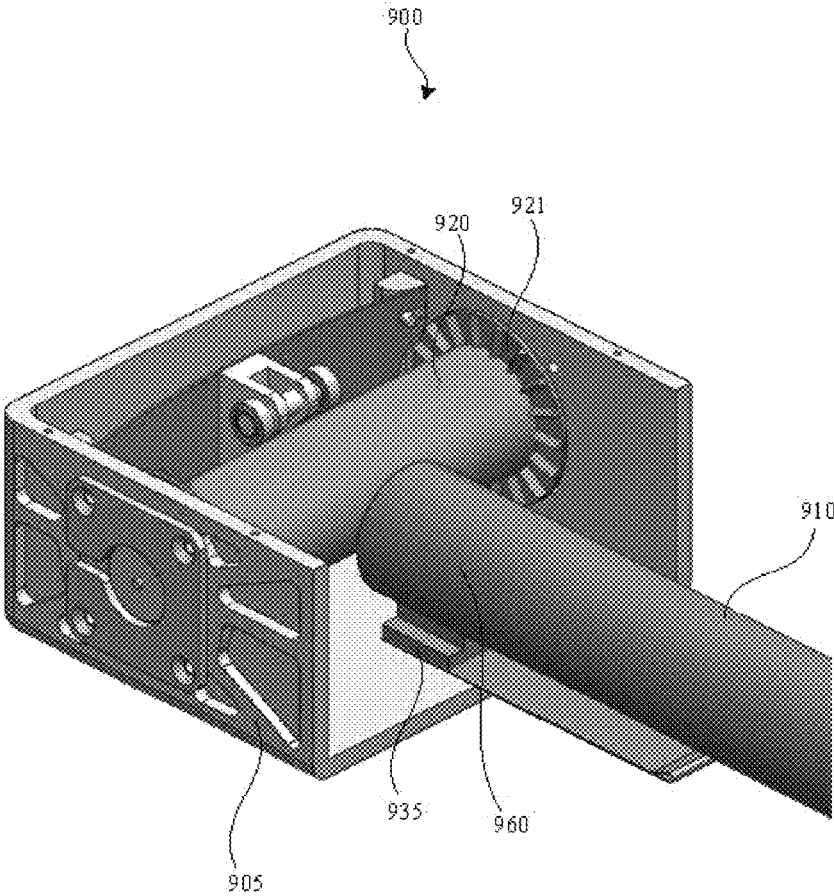

FIG. 18

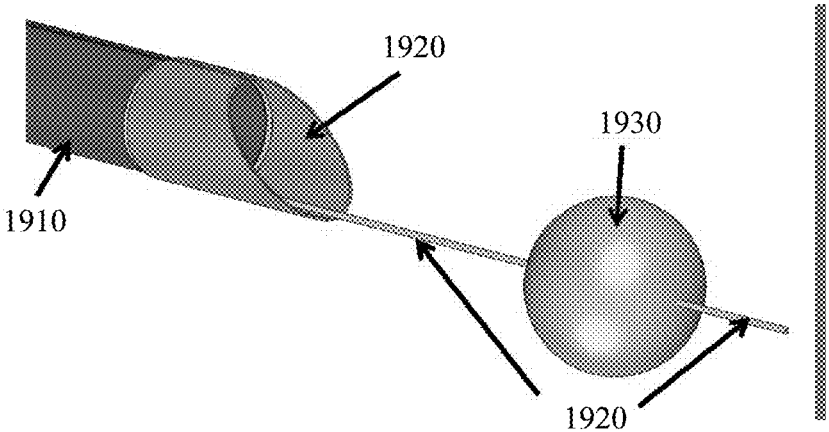

FIG. 19A

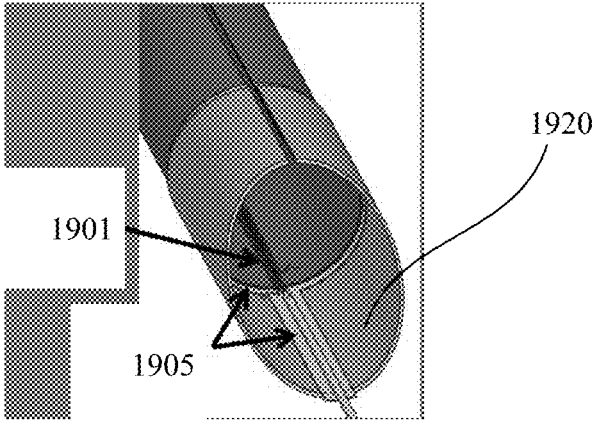

FIG. 19B

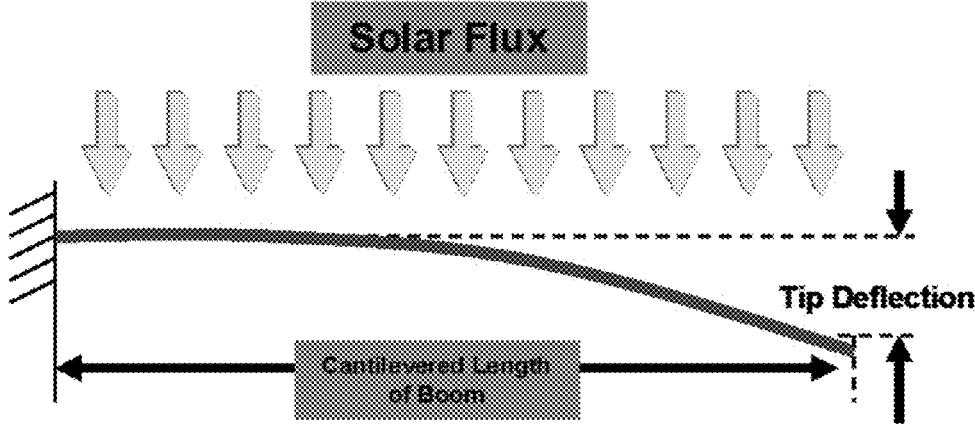

FIG. 20

MULTIPLE BOOM DEPLOYMENT

GOVERNMENT RIGHTS

This invention was made with government support under contract number NNX15CG38P awarded by the National Aeronautics and Space Administration (NASA). The government has certain rights in the invention.

CROSS-REFERENCE TO RELATED APPLICATION

This application is a non-provisional of U.S. Provisional Patent Application No. 62/150,965, filed Apr. 22, 2015, titled MULTIPLE BOOM DEPLOYMENT.

SUMMARY

Some embodiments of the invention include a multi-boom deployment device that includes a first spool, a first boom, a second boom, a third boom, and a fourth boom. The first boom having a cylindrical shape in a deployed configuration, a flattened shape in a stowed configuration, and a slit that extends along the longitudinal length of the first boom in the deployed configuration. In some embodiments, the first boom is stowed in the stowed configuration flattened and wrapped around the first spool. The second boom having a cylindrical shape in a deployed configuration, a flattened shape in a stowed configuration, and a slit that extends along the longitudinal length of the second boom in the deployed configuration. In some embodiments, the second boom is stowed in the stowed configuration flattened and wrapped around the first spool. The third boom having a cylindrical shape in a deployed configuration, a flattened shape in a stowed configuration, and a slit that extends along the longitudinal length of the third boom in the deployed configuration. In some embodiments, the third boom is stowed in the stowed configuration flattened and wrapped around the first spool. The fourth boom having a cylindrical shape in a deployed configuration, a flattened shape in a stowed configuration, and a slit that extends along the longitudinal length of the fourth boom in the deployed configuration. In some embodiments, the fourth boom is stowed in the stowed configuration flattened and wrapped around the first spool.

In some embodiments, the multi-boom deployment device may include a housing within which the first spool, the first boom, the second boom, the third boom, and the fourth boom are disposed in the stowed the stowed configuration.

In some embodiments, the multi-boom deployment device may include a housing having an aperture through which the first boom extends in the deployed configuration.

In some embodiments, the multi-boom deployment device may include a restraint mechanism configured to cover the aperture in the stowed configuration and open in the deployed configuration.

In some embodiments, the multi-boom deployment device may include a housing and a first root lock. In some embodiments, the first spool is disposed within the housing. In some embodiments, the first root lock may be disposed within the housing. In some embodiments, the root lock is position within the housing relative to the spool, wherein in the deployed configuration a proximal end of the first boom is wrapped around the root lock.

In some embodiments, the multi-boom deployment device may include a spring mechanism coupled with the

housing and the first root lock. In some embodiments, the spring mechanism is configured to move the root lock from a location in the stowed configuration into a position near the spool in the deployed configuration.

In some embodiments, the first boom and one or more of the second boom, the third boom, and the fourth boom are substantially orthogonal in the deployed configuration.

In some embodiments, the first boom and at least one of the second boom, the third boom, and the fourth boom are substantially parallel in the deployed configuration.

In some embodiments, the first boom transitions from the stowed configuration to the deployed configuration as the spool rotates around the axis, and wherein the second boom transitions from the stowed configuration to the deployed configuration as the spool rotates around the axis.

In some embodiments, the multi-boom deployment device may include a housing, wherein the first spool is disposed within the housing; a second spool disposed within the housing; and a fifth boom having a cylindrical shape in a deployed configuration, a flattened shape in a stowed configuration, and a slit that extends along the longitudinal length of the boom in the deployed configuration, wherein the fifth boom is stowed in the stowed configuration flattened and wrapped around the second spool.

Some embodiments of the invention include a boom deployment system. The boom deployment system, for example, may include a housing, a spool, a first boom, and a second boom. The spool may be disposed within the housing and configured to rotate around an axis that is fixed relative to the housing. The first boom and/or the second boom may have a cylindrical shape in a deployed configuration, a flattened shape in a stowed configuration, and a slit that extends along the longitudinal length of the boom in the deployed configuration. The first boom and/or the second boom may be stowed in the stowed configuration flattened and wrapped around the spool. The first boom and/or the second boom may transition from the stowed configuration to the deployed configuration as the spool rotates around the axis.

In some embodiments, the boom deployment system may include a first sensor coupled with the first boom and a second sensor coupled with the second boom.

In some embodiments, the boom deployment system may include a first wire coupled with the first boom and a second wire coupled with the second boom.

In some embodiments, in the deployed configuration the first boom is substantially perpendicular with the second boom.

In some embodiments, in the deployed configuration the first boom is substantially parallel with the second boom.

In some embodiments, the housing includes a first aperture through which the first boom extends in the deployed configuration, and wherein the housing includes a second aperture through which the second boom extends in the deployed configuration.

Some embodiments may include a satellite having a housing, a first spool disposed within the housing and configured to rotate around an axis that is fixed relative to the housing; and a first boom having a cylindrical shape in a deployed configuration, a flattened shape in a stowed configuration, and a slit that extends along the longitudinal length of the first boom in the deployed configuration, wherein the first boom is stowed in the stowed configuration flattened and wrapped around the first spool, the first boom transitions from the stowed configuration to the deployed configuration as the spool rotates around the axis; a second boom having a cylindrical shape in a deployed configura-

tion, a flattened shape in a stowed configuration, and a slit that extends along the longitudinal length of the second boom in the deployed configuration, wherein the second boom is stowed in the stowed configuration flattened and wrapped around the first spool the second boom transitions from the stowed configuration to the deployed configuration as the spool rotates around the axis; a second spool disposed within the housing and configured to rotate around an axis that is fixed relative to the housing; and a third boom having a cylindrical shape in a deployed configuration, a flattened shape in a stowed configuration, and a slit that extends along the longitudinal length of the third boom in the deployed configuration, wherein the third boom is stowed in the stowed configuration flattened and wrapped around the second spool, the third boom transitions from the stowed configuration to the deployed configuration as the second spool rotates around the axis.

In some embodiments, in the deployed configuration the third boom is substantially perpendicular with the second boom, and wherein in the deployed configuration the third boom is substantially perpendicular with the first boom.

In some embodiments, the satellite may include a first restraint mechanism configured to cover an aperture in the housing in the stowed configuration and open in the deployed configuration, wherein the third boom extends through the aperture in the deployed configuration.

In some embodiments, the satellite may include a first root plug disposed to couple with the first boom in the deployed configuration; a second root plug disposed to couple with the second boom in the deployed configuration; and a third root plug disposed to couple with the third boom in the deployed configuration.

BRIEF DESCRIPTION OF THE FIGURES

These and other features, aspects, and advantages of the present disclosure are better understood when the following Detailed Description is read with reference to the accompanying drawings.

FIG. 1 illustrates a satellite with booms in a stowed configuration according to some embodiments.

FIG. 2 illustrates a satellite with booms in a deployed configuration according to some embodiments.

FIG. 3 illustrates an example boom according to some embodiments.

FIG. 4 illustrates a multi-boom deployment device in a stowed configuration according to some embodiments.

FIG. 5 illustrates a multi-boom deployment device in a partially-deployed configuration according to some embodiments.

FIG. 6 illustrates a multi-boom deployment device in a mostly-deployed configuration according to some embodiments.

FIG. 7 illustrates a multi-boom deployment device in a deployed configuration according to some embodiments.

FIG. 8 is a side view of a multi-boom deployment device according to some embodiments.

FIG. 9 illustrates a single-boom deployment device in a stowed configuration according to some embodiments.

FIG. 10 illustrates a single-boom deployment device in a mostly-stowed configuration according to some embodiments.

FIG. 11 illustrates a single-boom deployment device in a mostly-deployed configuration according to some embodiments.

FIG. 12 illustrates a single-boom deployment device in a deployed configuration according to some embodiments.

FIG. 13A illustrates a single-boom deployment device in a deployed state.

FIG. 13B illustrates a single-boom deployment device in the deployed state.

FIG. 14A illustrates a plurality of teeth along the length of the slit in an unlocked configuration.

FIG. 14B illustrates the plurality of teeth in a locked configuration.

FIG. 15A and FIG. 15B illustrate a slit-lock mechanism according to some embodiments.

FIG. 16 illustrates a single-boom deployment device in a stowed configuration according to some embodiments.

FIG. 17 illustrates the single-boom deployment device in a partially-deployed configuration according to some embodiments.

FIG. 18 illustrates the single-boom deployment device in a deployed configuration according to some embodiments.

FIG. 19A and FIG. 19B illustrate an example embodiment of a distal end of a boom.

FIG. 20 illustrates the relationship between the solar flux incident along a boom and the resulting "thermal bending" on the boom according to some embodiments.

DETAILED DESCRIPTION

Some embodiments of the invention include a multi-boom deployment device and a single-boom deployment device. Some embodiments may also include various satellite systems that include one or more multi-boom deployment devices and/or one or more single-boom deployment devices. In some embodiments, the multi-boom deployment device may include a plurality of booms that are flattened and wrapped around a spool within a housing in a stowed configuration. In some embodiments, in a deployed configuration the booms may extend away from the housing a plurality of directions. The multi-boom deployment device and/or the single-boom deployment device may be used for any number of purposes.

Some embodiments may be used for measuring electric fields, which may include the measurement of voltage potential between three pairs of electrodes separated along orthogonal axes using the booms.

In some embodiments, the satellite system may deploy two, three, four, or more booms from a single deployment mechanism or deployment drum or spool. Each boom may, for example, include a tubular longeron with a slit along the length of the longeron that may or may not include teeth on one or more sides of the longeron. In some embodiments, six booms may be deployed using as few as two or three deployment mechanisms or deployment drums or spools. In some embodiments, the longeron may be flattened and/or rolled along the longitudinal length of the longeron such as, for example, for stowage. In some embodiments, the longeron may include teeth along the length of the slit such that the teeth can join together after deployment.

FIG. 1 illustrates a satellite 100, which may include a satellite body 105 according to some embodiments. In some embodiments, the satellite 100 may include a plurality of boom deployment devices such as, for example, a multi-boom deployment device 110 and/or two single-boom deployment devices 115.

In some embodiments, some components of the satellite 100 may be configured to be packaged within a small volume such as, for example, a box or the volume of a satellite body 105. In some embodiments, the satellite body 105 may be configured to include any number of other devices within the volume of the satellite body 105, such as,

for example: a 3-axis electric field sensor, a 3D vector electric field instrument, a magnetometer, particle detector, Langmuir probe, an ion drift meter, a flux gate magnetometer, electrostatic analyzer, a propulsion system, a controller, communication systems, or any other desirable device to be housed within the satellite body **105**. In some embodiments, spacecraft functionality for the satellite body **105** may be provided by a satellite bus such as the XB-1 Precision Pointing XACT Based satellite bus or any other satellite bus configured to perform functions such as ADCS, C+DH, Power, RF/Comm, GPS or 3-axis stabilized capability.

In some embodiments, various science objectives can be met using multiple satellites in Low Earth Orbit (LEO) that include 3-axis electric field instruments. One such deployment system may include an Electric Potential and Field Instrument for a satellite that can be accommodated in less than half of a 6U satellite. In some embodiments, this may include a deployable composite boom technology with lightweight, stiff, straight, thermally stable booms capable of being stowed within a satellite form factor. In some embodiments, a satellite may include one or more deployable booms with lengths configured to accomplish satellite missions.

In some embodiments, in the stowed configuration two or more booms may be wrapped around the same drum or spool. In some embodiments, each boom may include a slit tube longeron comprising a slit that extends along the longitudinal length of the longeron. In some embodiments, the longeron may be flattened and/or rolled along the longitudinal length of the longeron such as, for example, for stowage. In some embodiments, the longeron may include teeth along the length of the slit such that the teeth can join together after deployment.

FIG. 2 illustrates a satellite **100** with booms **205** deployed. The satellite **100** may include internal electronics and spherical sensors mounted on long rigid graphite composite booms coupled with the booms **205**. In some embodiments, such sensors may be configured to form three orthogonal dipoles or to act individually depending upon the desired measurement mode. The booms **205** may be composed of a sufficiently rigid material, such as graphite for example, that enables the instrument to be accommodated on a multi-axis stabilized satellite platform. In some embodiments the booms **205** may be configured to form any number of dipole lengths such as 4 m, 5 m, or any other length. Additionally, the booms **205** may be configured to be deployable and retractable. The satellite **100** may include any number of booms **205**.

FIG. 3 illustrates an example boom **305** according to some embodiments. The boom **305** can be flattened and rolled for stowage and then regain its original, unflattened, circular, elliptical, or semi-circular cross-section during deployment. The boom **305** may include a long tube with one or more slits **308** or gaps that extend through all or a portion of the longitudinal length of the boom **305**. The boom **305** may include a hollow interior. The slit **308** may allow the boom **305** to be flattened and rolled into a stowed or rolled configuration or extended in a deployed configuration. When rolled, various different booms may be stacked, nested, aligned and/or combined and collectively rolled together. The boom **305** may be constructed from any type of material that may, for example, include metal, graphite, fiber, resins, shape memory materials, composite materials, polymers, etc. In some embodiments, the boom **305** may be constructed from a composite material with a number of plies embedded with a resin.

The boom **305** may have a tubular shape in the deployed configuration and flattened and rolled in the stowed configuration. When rolling a boom **305**, the tubular cross-section of the boom **305** can be flattened and/or the boom **305** may be opened along the longitudinal length of the boom **305**. The boom **305** can then be rolled into a stowed configuration. In some embodiments, during stowage, portions of the boom **305** may be progressively flattened as the boom **305** is rolled up. In some embodiments, multiple booms can be stacked upon one another, nested or embedded within each other in the tubular or deployed configuration. The combined boom stack can then be rolled along the longitudinal length of the booms into the stowed configuration.

In some embodiments, the boom **305** may include more than one slit along the longitudinal length of the boom **305**.

FIG. 4 illustrates a multi-boom deployment device **400** in a stowed configuration according to some embodiments. The multi-boom deployment device **400** may include stow and/or deploy any plurality of booms such as, for example, two, three, four, five, six, seven, etc. booms.

The multi-boom deployment device **400** shown in FIG. 4 includes four booms flattened and rolled about a spool **470**. The four booms in this example include boom **410A**, boom **410B**, boom **410C**, and boom **410D** (collectively and/or individually boom **410**). The booms **410** in the stowed configuration comprise flattened and wound booms **475** that are wound about the spool **470**. Each boom **410** may, for example, be similar to boom **305** and/or may include the characteristics and/or properties of boom **305**.

In some embodiments, the spool **470** may include a motor such as, for example, a stepper motor (e.g., the Faulhaber AM 0820 or the like). In some embodiments, the motor may be disposed within the interior of the spool **470**. In some embodiments, the motor may be used to drive out the boom **410**.

In some embodiments, the boom **410** may include any of a variety of deployable composite booms that range from 12.7 mm (0.5") to 203 mm (8.0") diameter and up to 23 H meters (75-ft) in length. In some embodiments, the boom **410** may also include slit-tube composite boom that can be flattened and rolled around the spool **470** for storage. Some embodiments may include a boom **410** configured to be 1.5 m long, with a 19 mm diameter motor-driven boom **410** that may take up less than 50% of a 1U satellite volume and weighs less than 200 g.

In some embodiments, the boom **410** may be rotated using strain energy stored in one or more of the booms. For example, while the booms **410** are being flattened and rolled into the stowed configuration strain energy is introduced into the booms **410**. The strain energy, for example, can provide a bias in the booms toward the deployed state. Thus, when a restraint mechanism holding the booms in place is released, the strain energy in the booms **410** will cause the booms to unroll and deploy. Various other mechanisms may be used to unroll the booms **410** on the spool **470**.

In some embodiments, the boom **410** may be configured to survive the mechanical strain of being wrapped around the spool **470**, while also having sufficient axial stiffness and a coefficient of thermal expansion ("CTE"), allowing for tip stability in a typical on-orbit environment. In some embodiments, the size of the boom **410** and the sensor **415** may be configured to reduce shadowing and influences on electric field detection.

In some embodiments, the boom **410** may be configured to be sufficiently long and narrow as to reduce the influence of the satellite **100** on a DC e-field vector measurement.

The booms **410** may be stowed within housing **480**. The housing **480** may comprise any geometric shape and/or may have any size configured to stow and/or deploy the booms **410**. In this example, the housing comprise a roughly cube shape. In some embodiments, the housing may be disposed within a satellite or other body.

In some embodiments, each boom **410** may be coupled with a corresponding boom wire **465** (e.g., boom wire **465A**, boom wire **465B**, boom wire **465C**, and/or boom wire **465C** collectively and/or individually boom wire **465**) and/or a corresponding sensor **415** (e.g., sensor **415A**, sensor **415B**, sensor **415C**, and/or sensor **415C** collectively and/or individually sensor **415**). The boom wire **465** may include any type of wire such as, for example, wire that can communicate sensor data or signals from the sensor **415** to data sampling device. In some embodiments, the sensor **415** may include an electric field sensor, a magnetic field sensor, a temperature sensor, etc.

The housing **480** may include a plurality of restraint mechanisms **405** (e.g., restraint mechanism **405A**, restraint mechanism **405B**, restraint mechanism **405C**, and/or restraint mechanism **405C** collectively and/or restraint mechanism **405**).

In some embodiments, the restraint mechanisms **405** may be spring loaded so that when an electric release on the restraint mechanisms **405** is activated, the restraint mechanisms may spring open as shown in FIG. 5. Each boom **410** may be disposed near, include, and/or be associated with a corresponding restraint mechanism **405** such that the boom **410** may be deployed through the corresponding restraint mechanism **405** during deployment. The restraint mechanism **405** may include a spring loaded device held closed with any number of simple release devices, such as a burn wire. The restraint mechanism **405** may be further configured to be released by a single command from the satellite **100**. The restraint mechanism may then be configured to pop open. In some embodiments, the sensor **415** may be configured to be released once the restraint mechanism **405** has opened. In some embodiments, embodiments the restraint mechanism may include a strap, cord, wire, latch, release, clamp, etc.

In the example shown in FIG. 4, the restraint mechanism **405** comprises a door. In the stowed configuration, for example, the door may be closed. The closed doors, for example, may secure the boom **410** within the housing. In some embodiments, the restraint mechanisms **405** may include a socket that is sized and/or configured to couple with the sensor **415**, for example, to secure the sensor while in the stowed configuration.

In some embodiments, the multi-boom deployment device **400** may include a boom deployment guide that includes a first boom guide arm **420** (first boom guide arm **420A**, first boom guide arm **420B**, first boom guide arm **420C**, and/or first boom guide arm **420D** collectively and/or individually first boom guide arm **420**), a second boom guide arm **421** (second boom guide arm **421A**, second boom guide arm **421B**, second boom guide arm **421C**, and/or second boom guide arm **421D** collectively and/or individually first boom guide arm **421**), and/or a boom guide cross member **435** (e.g., boom guide cross member **435A**, boom guide cross member **435B**, boom guide cross member **435C**, and/or boom guide cross member **435D** collectively and/or individually boom guide cross member **435**). The boom guide arm **420** and/or the boom guide arm **421** may be biased toward the flattened and wound booms **475** on the spool **470**. In some embodiments, each of the boom deployment guides may include a plurality of rollers or wheels such

as, for example, a first wheel **430** (e.g., first wheel **430A**, first wheel **430B**, first wheel **430C**, and/or first wheel **430D** collectively and/or individually first wheel **430**) and/or a second wheel **431** (e.g., second wheel **431A**, second wheel **431B**, second wheel **431C**, and/or second wheel **431D** collectively and/or individually second wheel **431**). In some embodiments, the boom deployment guides may guide a corresponding boom toward an exit aperture of the housing **480** during deployment.

In some embodiments, the multi-boom deployment device **400** may include a plurality of root plugs **425** (e.g., root plugs **425A**, root plugs **425B**, root plugs **425C**, and/or root plugs **425D** collectively and/or individually root plugs **425**). Each boom **410** may couple with a corresponding root plug **425** after deployment to secure the boom **410** with the housing **480** as shown in FIG. 7. In some embodiments, each root plug **425** may be coupled with a spring mechanism **460**. In some embodiments, the spring mechanism **460** (e.g., spring mechanism **460A**, spring mechanism **460B**, spring mechanism **460C**, and/or spring mechanism **460D** collectively and/or individually spring mechanism **460**) may be coupled with the housing **480**. In some embodiments, the spring mechanism **460** may rotate the root plug **425** into a position near the proximal end of the boom **410** so that the proximal end of the boom **410** may wrap around the root plug **425** when deployed and formed into a cylindrical shape in the deployed configuration. In the stowed configuration, for example, the root plug **425** may be positioned away from the spool **470** and/or the flattened and wound booms **475**, and/or nearer the interior wall of the housing **480**.

FIG. 5 illustrates a multi-boom deployment device **400** in a partially-deployed configuration according to some embodiments. In this configuration, the booms are partially stowed within the housing. For instance, a portion of each boom **410** may still be wrapped around the spool **470**. In this example, the restraint mechanisms **405** are open as shown in the figure. When the restraint mechanisms open an aperture in the housing **480** is opened through which each of the booms may be deployed. In this example, each of the four booms are beginning to exit the housing **480** through the apertures. Also, in this configuration, the sensors **415** and/or the boom wires **465** have exited the housing **480** through the apertures.

The spool **470**, in this configuration, has been rotated clockwise to a new angular position in comparison to the angular position of the spool **470** in FIG. 4. This rotation may cause the booms **410** to uncoil from the spool **470** and extend through the apertures in the housing **480**. As the booms **410** extend they unflatten and regain their tubular shape. As the booms **410** roll off the spool **470** the distal end for the boom **410** may be directed toward the aperture by the boom deployment guide.

FIG. 6 illustrates a multi-boom deployment device **400** in a mostly-deployed configuration according to some embodiments. In this configuration, the booms **410** are nearly completely deployed or unrolled from the spool **470**.

FIG. 7 illustrates a multi-boom deployment device **400** in a deployed configuration according to some embodiments. In this configuration, the booms **410** are unrolled from the spool **470**. In some embodiments, the booms **410** may still be coupled with the spool **470** such as, for example, at the proximal end of the booms **410**. The proximal end of the boom **410** (e.g., the end of the boom **410** closes to the spool **470**) may transition from a flattened state to a tubular state; and each of the proximal ends of the booms **410**, for example, may be wrapped around the root plug **425**. The root plug **425**, for example, may provide structural stability

to the proximal end of the boom **410**. In some embodiments, the boom **410** may be coupled with the root plug **425** via an additional clamping mechanism that may secure the boom **410** with the root plug **425**.

Each of the booms **410** of multi-boom deployment device **400** are shown being deployed at substantially right angles from the two adjacent booms **410**. In some embodiments, the booms **410** of the multi-boom deployment device **400** may be configured to deploy at any number of angles, for example at a 45 degree angle with respect to the side of the housing **480**. In some embodiments, the booms **410** may be deployed at 90 degrees relative to one another. Alternatively or additionally, any number of booms **410** may be deployed at any number of angles relative to one another such as, for example, two booms, three boom, five booms, six booms, seven booms, eight booms, etc.

At the end of deployment, the spool **470** may be configured to stop against a hard stop and lock in position by the recovered cross section of the boom **410**. In embodiments including a regained cross-section, the boom **410** may have increased stiffness and strength near the multi-boom deployment device **400**. Such increased strength may also increase the pointing accuracy of a longer and narrower boom **410**.

FIG. **8** is a side view of a multi-boom deployment device **400** according to some embodiments.

FIG. **9** illustrates a single-boom deployment device **900** in a stowed configuration according to some embodiments. The single-boom deployment device **900** includes a housing **905** with an openable restraint mechanism **910**. A spool **920** is disposed within the housing. A boom **915** is flattened and wrapped around the spool **920**. In some embodiments, the boom may be coupled with a sensor **930** and/or a boom wire **925**. The sensor **930** may be the same or similar as sensor **415**. The boom wire **925** may be the same or similar as the boom wire **465**. A root plug **935** may be coupled with the housing with a spring mechanism **940**. The spring mechanism **940** may bias the root plug so that the root plug **935** may rotate into a position relative to the boom **915** in the deployed configuration.

FIG. **10** illustrates a single-boom deployment device **900** in a mostly-stowed configuration according to some embodiments. In this configuration, the restraint mechanism **910** has been opened creating an aperture in the housing **905** through which the boom **915** may extend. The spool **920** may rotate counter-clockwise causing the boom **915** to extend. In some embodiments, the root plug **935** may rotate into the deployed position as shown in FIG. **10**.

FIG. **11** illustrates a single-boom deployment device **900** in a mostly-deployed configuration according to some embodiments. In this configuration, most of the boom **915** has been unwound from the spool **920** and/or deployed. As the boom **915** deploys, it forms into an extended, tubular shape as shown in FIG. **11**. The boom **915** deploys as the spool rotates counter-clockwise.

FIG. **12** illustrates a single-boom deployment device **900** in a deployed configuration according to some embodiments. In the deployed configuration, the proximal end of the boom **915** is wrapped around the root plug **935**. The root plug **935** may provide stability to the proximal end of the boom **915**. In some embodiments, an additional clamp may be coupled with the boom **915** and/or the root plug **935**.

FIG. **13A** illustrates a single-boom deployment device in a deployed state. FIG. **13B** illustrates a single-boom deployment device in the deployed state.

In some embodiments, a boom may include a slit-lock mechanism that may include teeth formed along both side of the longitudinal length of a slit of the tubular boom. FIG.

14A illustrates a plurality of teeth along the length of the slit in an unlocked configuration. FIG. **14B** illustrates the plurality of teeth in a locked configuration. In some embodiments, the slit-lock may improve the stability of the boom when deployed.

In some embodiments, the teeth on the boom may be aligned with keys on a spool when the boom is stowed with the spool. This alignment may allow the teeth to be engaged to keys on the end caps of a spool as shown in FIG. **15A** and FIG. **15B**. The slot and key engagement may allow one or more booms to unspool in a controlled manner such as, for example, at precisely the same rate every time. In some embodiments, the engagement between the teeth and the spool may also allow much higher forces to be driven from the spool into the boom as it deploys. In some embodiments, the engagement between the teeth and the spool may allow a significant amount of tension to be driven into the boom or booms during deployment.

FIG. **16** illustrates a single-boom deployment device **900** in a stowed configuration according to some embodiments. In this example, the boom **915** includes a plurality of teeth **926** that engage with keys **921** on the spool **920**.

FIG. **17** illustrates the single-boom deployment device **900** in a partially-deployed configuration according to some embodiments. As the boom **915** deploys from the spool **920**, a transition zone is created in the boom **915** that is partially between a flattened boom and a tubular boom. This transition zone can be an area where the boom **915** is less rigid and/or weaker.

FIG. **18** illustrates the single-boom deployment device **900** in a deployed configuration according to some embodiments. In the deployed configuration, the proximal end **960** of the boom **915** is wrapped around the root plug **935**. As shown in the figure, the spool **920** includes a plurality of keys **921**.

FIG. **19A** and FIG. **19B** illustrate an example embodiment of a distal end of a boom **1910**, which may include similar features as the boom **305**, **410**, and/or **910**. The boom **1910** may include a wire harness **1901**. The boom **1910** may be configured to control surface voltage potential across the various components of the boom **1910**, which may include a sphere, a guard, a stub, etc. In some embodiments, control of voltage across various surfaces may be accomplished by utilizing an insulating layer **1905** on the boom **1910**, such as polymer scrim at each bondline.

The wire harness **1901** may be configured to be bonded to the inside of the boom **1910** and roll up with the boom **1910** upon deployment and retraction. The wire harness **1901** may include the ability to accommodate storage/deployment cycles. In some embodiments, the wire harness **1901** may be routed through the boom **1910** from the internal electronics to the tip of the boom **1910**, such that electrical connectivity to the controlled surfaces may be achieved with a wire harness **1901**. In some embodiments the wire harness **1901** may be a ribbon cable consisting of a plurality of small gauge wires (36-40 awg). In some embodiments, the wire harness **1901** may be a flat flex circuit.

In some embodiments, the boom **1910** may include a conductive surface **1920** on the outermost portion of the boom and include an attachment point for electrical connection to the wire harness **1901**. The conductive surface **1920** may be atomic oxygen resistant, such as, for example, gold, TiN, or AlTiN. In some embodiments, the conductive surface **1920** may be a surface treatment or a bulk conductor. Embodiments including a surface treatment may include the application of a thin TiN coating. Such embodiments may apply conductive coatings at relatively low temperatures.

Some embodiments may include the application of a bulk conductor to the tip of the boom **1910** as the conductive surface **1920**. For example, the conductive surface **1920** may be a thin section of stainless steel bonded to the tip of the boom **1910**.

In some situations, measurements such as, for example, DC e-field measurements can be influenced by the geometry and design of a satellite and the sensor **415** location. The electrostatic charge of the spacecraft creates a disturbance in the electric field that may be subtracted from the measurement. Therefore, reducing the influence of the spacecraft is desired to obtain more accurate measurements. In some embodiments, this may be done by moving the electric field sensor away from the spacecraft body. In some embodiments, the deployable structure itself may also disturb the electric field.

In some embodiments a long and narrow boom may reduce the influence of the boom on an electric field sensor. However, some embodiments may include the boom configured with deployed stiffness, natural frequency, and pointing stability sufficient to reduce influence on an electric field sensor. Some embodiments may include a boom configured to be 2 m long with a deployed diameter that is less than 20 mm.

In some embodiments a boom may be configured to have a greater deployed stiffness than typical satellite appendages, such as carpenter's tape springs or conventional slit-tube beams. For example, a boom may include a stability of 1 degree between orthogonal pairs. In some embodiments, a boom may include locking edge features between lateral edges of the boom, sufficient to increase deployed stiffness and improving stability in both bending and torsion.

Some embodiments may include compositions configured to increase thermal stability, which may increase instrument performance. For example, solar flux along the boom may result in a temperature gradient across a section of a boom, resulting in increased "thermal bending", as illustrated in FIG. **20**. This phenomenon famously induced "thermal flutter" in the stainless steel slit-tubes of the 1st generation Hubble solar arrays. However, embodiments of the boom **410** may include materials, such as graphite composite, configured to have a reduced CTE, increasing the pointing accuracy in large on-orbit thermal gradients. In some embodiments, the boom **410** may be configured to experience less than a 0.1 degree pointing shift as a result of thermal bending.

In some embodiments the boom **410** and the sensor **415** may be configured to have a first natural frequency of about 2 Hz.

Modifications may be made without changing the scope of the disclosure. Additional embodiments may also include a magnetometer boom configured as particle or field sensors that separate from a spacecraft. Additional embodiments may include a canisterized boom configured to be used as a gravity gradient boom, or as a deployable structure to support solar arrays, solar sails, antennas, or drag sails. The components and features discussed in the disclosure may be configured to function at temperatures from 4 K to 500 K.

The term "substantially" means within 5% or 10% of the value referred to or within manufacturing tolerances.

Numerous specific details are set forth herein to provide a thorough understanding of the claimed subject matter. However, those skilled in the art will understand that the claimed subject matter may be practiced without these specific details. In other instances, methods, apparatuses, or

systems that would be known by one of ordinary skill have not been described in detail so as not to obscure claimed subject matter.

Embodiments of the methods disclosed herein may be performed in the operation of such computing devices. The order of the blocks presented in the examples above can be varied—for example, blocks can be re-ordered, combined, and/or broken into sub-blocks. Certain blocks or processes can be performed in parallel.

The use of "adapted to" or "configured to" herein is meant as open and inclusive language that does not foreclose devices adapted to or configured to perform additional tasks or steps. Additionally, the use of "based on" is meant to be open and inclusive, in that a process, step, calculation, or other action "based on" one or more recited conditions or values may, in practice, be based on additional conditions or values beyond those recited. Headings, lists, and numbering included herein are for ease of explanation only and are not meant to be limiting.

While the present subject matter has been described in detail with respect to specific embodiments thereof, it will be appreciated that those skilled in the art, upon attaining an understanding of the foregoing, may readily produce alterations to, variations of, and equivalents to such embodiments. Accordingly, it should be understood that the present disclosure has been presented for purposes of example rather than limitation, and does not preclude inclusion of such modifications, variations, and/or additions to the present subject matter as would be readily apparent to one of ordinary skill in the art.

That which is claimed:

1. A boom deployment system comprising:

a housing;

a first spool disposed within the housing;

a first boom having a proximal end, a distal end, and a cylindrical shape extending in a first direction out of the housing in a deployed configuration, a flattened shape in a stowed configuration, and a slit that extends along a longitudinal length of the first boom in the deployed configuration, wherein the first boom is stowed in the stowed configuration flattened and wrapped around the first spool, wherein the distal end of the first boom comprises a first sensor;

a second boom having a proximal end, a distal end, and a cylindrical shape extending in a second direction out of the housing at an angle offset from the first boom in a deployed configuration, a flattened shape in a stowed configuration, and a slit that extends along a longitudinal length of the second boom in the deployed configuration, wherein the second boom is stowed in the stowed configuration flattened and wrapped around the first spool, wherein the distal end of the second boom comprises a second sensor;

a third boom having a proximal end, a distal end, and a cylindrical shape extending in a third direction out of the housing at an angle offset from the first boom and the second boom in a deployed configuration, a flattened shape in a stowed configuration, and a slit that extends along a longitudinal length of the third boom in the deployed configuration, wherein the third boom is stowed in the stowed configuration flattened and wrapped around the first spool, wherein the distal end of the third boom comprises a third sensor; and

a fourth boom having a proximal end, a distal end, and a cylindrical shape extending in a fourth direction out of the housing at an angle offset from the first boom, the second boom, and the third boom in a deployed con-

13

- figuration, a flattened shape in a stowed configuration, and a slit that extends along a longitudinal length of the fourth boom in the deployed configuration, wherein the fourth boom is stowed in the stowed configuration flattened and wrapped around the first spool, wherein the distal end of the fourth boom comprises a fourth sensor.
2. The boom deployment system according to claim 1, further comprising a restraint mechanism configured to cover the aperture in the stowed configuration and open in the deployed configuration.
3. The boom deployment system according to claim 1, further comprising:
 a first root lock disposed within the housing, wherein the root lock is position within the housing relative to the spool, wherein in the deployed configuration a proximal end of the first boom is wrapped around the root lock.
4. The boom deployment system according to claim 3, further comprising a spring mechanism coupled with the housing and the first root lock, wherein the spring mechanism is configured to move the root lock from a location in the stowed configuration into a position near the spool in the deployed configuration.
5. The boom deployment system according to claim 1, wherein the first boom and one or more of the second boom, the third boom, and the fourth boom are substantially orthogonal in the deployed configuration.
6. The boom deployment system according to claim 1, wherein the first boom transitions from the stowed configuration to the deployed configuration as the spool rotates around an axis, and wherein the second boom transitions from the stowed configuration to the deployed configuration as the spool rotates around an axis.
7. The boom deployment system according to claim 1, further comprising:
 a housing, wherein the first spool is disposed within the housing;
 a second spool disposed within the housing; and
 a fifth boom having a cylindrical shape in a deployed configuration, a flattened shape in a stowed configuration, and a slit that extends along a longitudinal length of the boom in the deployed configuration, wherein the fifth boom is stowed in the stowed configuration flattened and wrapped around the second spool.
8. A boom deployment system comprising:
 a housing having a first aperture and a second aperture, the second aperture being offset from the first aperture;

14

- a spool disposed within the housing and configured to rotate around an axis that is fixed relative to the housing; and
 a first boom having a proximal end, a distal end, and a cylindrical shape extending in a first direction out of the first aperture in the housing at an angle offset from the first boom in a deployed configuration, wherein the proximal end of the first boom is coupled with the spool, wherein the first boom has a flattened shape in a stowed configuration, and a slit that extends along a longitudinal length of the first boom in the deployed configuration, wherein the first boom is stowed in the stowed configuration flattened and wrapped around the spool, the first boom transitions from the stowed configuration to the deployed configuration as the spool rotates around the axis, wherein the distal end of the first boom comprises a first sensor; and
 a second boom having a proximal end, a distal end, and a cylindrical shape extending in a second direction out of the second aperture of the housing in a deployed configuration, wherein the proximal end of the second boom is coupled with the spool, wherein the second boom has a flattened shape in a stowed configuration, and a slit that extends along a longitudinal length of the second boom in the deployed configuration, wherein the second boom is stowed in the stowed configuration flattened and wrapped around the spool, where in the slit in the second boom faces the same axial direction as the slit in the first boom; the second boom transitions from the stowed configuration to the deployed configuration as the spool rotates around the axis, where in the distal end of the second boom comprises a second sensor.
9. The boom deployment system according to claim 8, further comprising a first sensor coupled with the first boom and a second sensor coupled with the second boom.
10. The boom deployment system according to claim 8, further comprising a first wire coupled with the first boom and a second wire coupled with the second boom.
11. The boom deployment system according to claim 8, wherein in the deployed configuration the first boom is substantially perpendicular with the second boom.
12. The boom deployment system according to claim 8, wherein the housing includes a first aperture through which the first boom extends in the deployed configuration, and wherein the housing includes a second aperture through which the second boom extends in the deployed configuration.

* * * * *