



WHITE SANDS TEST FACILITY

ASTM G86 Energy vs. Momentum

Steven A. Mathe, NASA White Sands Test Facility,
Laboratories Department

Stephen F. Peralta, NASA White Sands Test Facility,
Laboratories Office

ASTM G86 Is Broad

- Covers Ambient and Pressurized testers
- Ambient tester more controlled
 - Specified striker pin design
 - Minimum base requirements
- Pressurized system only has examples

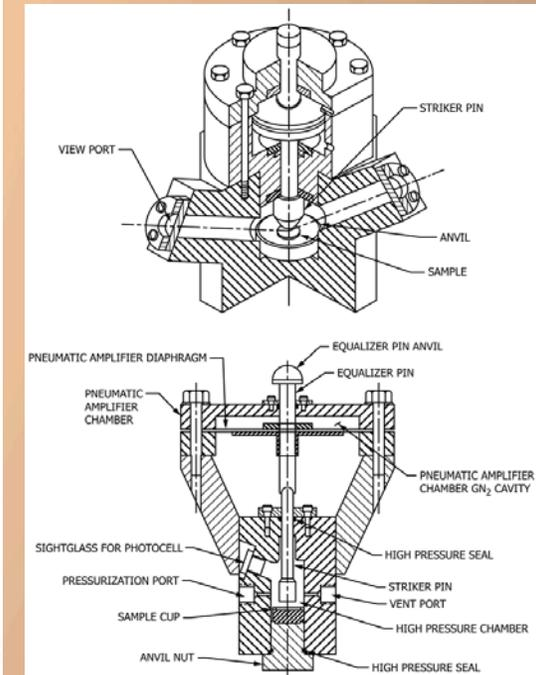
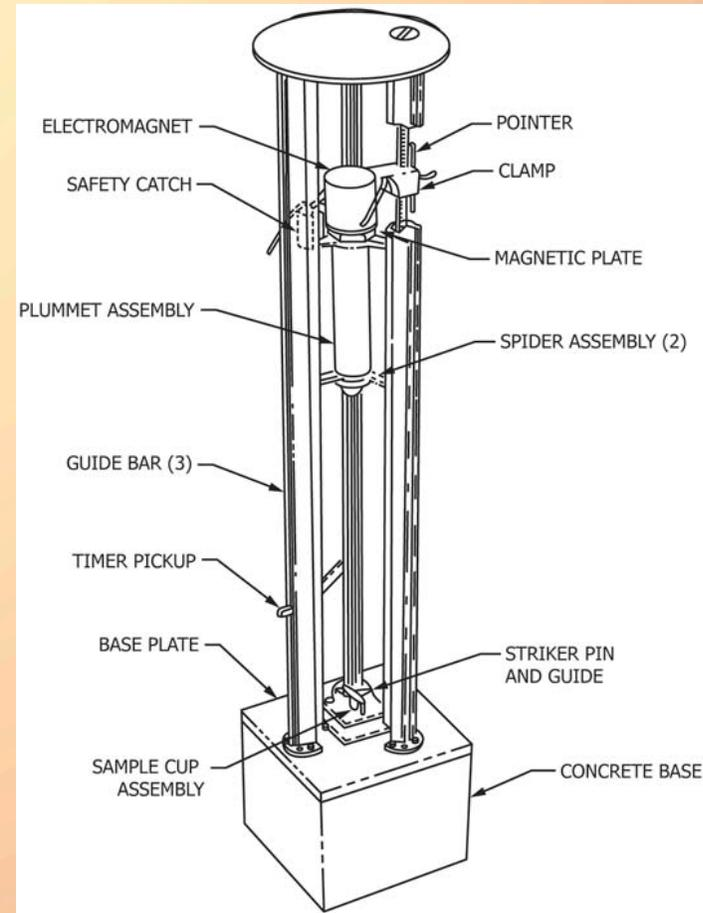

Measuring Impacts

- Standard measuring sticks are dent blocks, minimum slope
- Configurational differences result in different impacts (NASA-TM-74106)
- Compensate for losses by adding potential energy



Energy vs. Momentum

$$E = mgh$$

$$mgh = \frac{1}{2}mv^2$$
$$v = \sqrt{2gh}$$

$$p = mv = m\sqrt{2gh}$$

$$v = gt$$

$$h = \frac{1}{2}gt^2$$

$$t = \sqrt{\frac{2h}{g}}$$

$$v = g\sqrt{\frac{2h}{g}} = \sqrt{2gh}$$

Energy vs. Momentum

Mass = $2m$, Height = h

- $E = (2m)gh = 2mgh$
- $p = (2m)\sqrt{2gh}$

Mass = m , Height = $2h$

- $E = mg(2h) = 2mgh$
- $p = m\sqrt{2g(2h)} = 2m\sqrt{gh}$

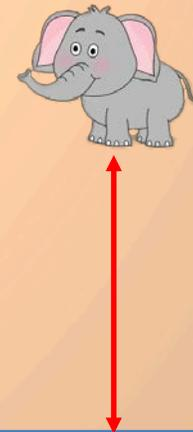
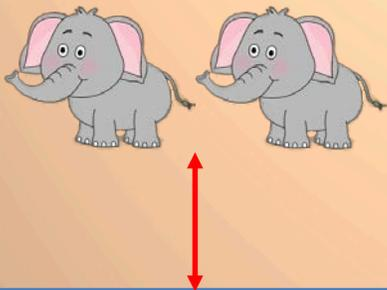

- Same E , $\sqrt{2}$ more p

Approach

- Impacts at various Energy/Momentum combinations
- Two dent block materials
 - 304 Stainless Steel
 - 110 Copper
- Instrumented plummet to collect other impact data



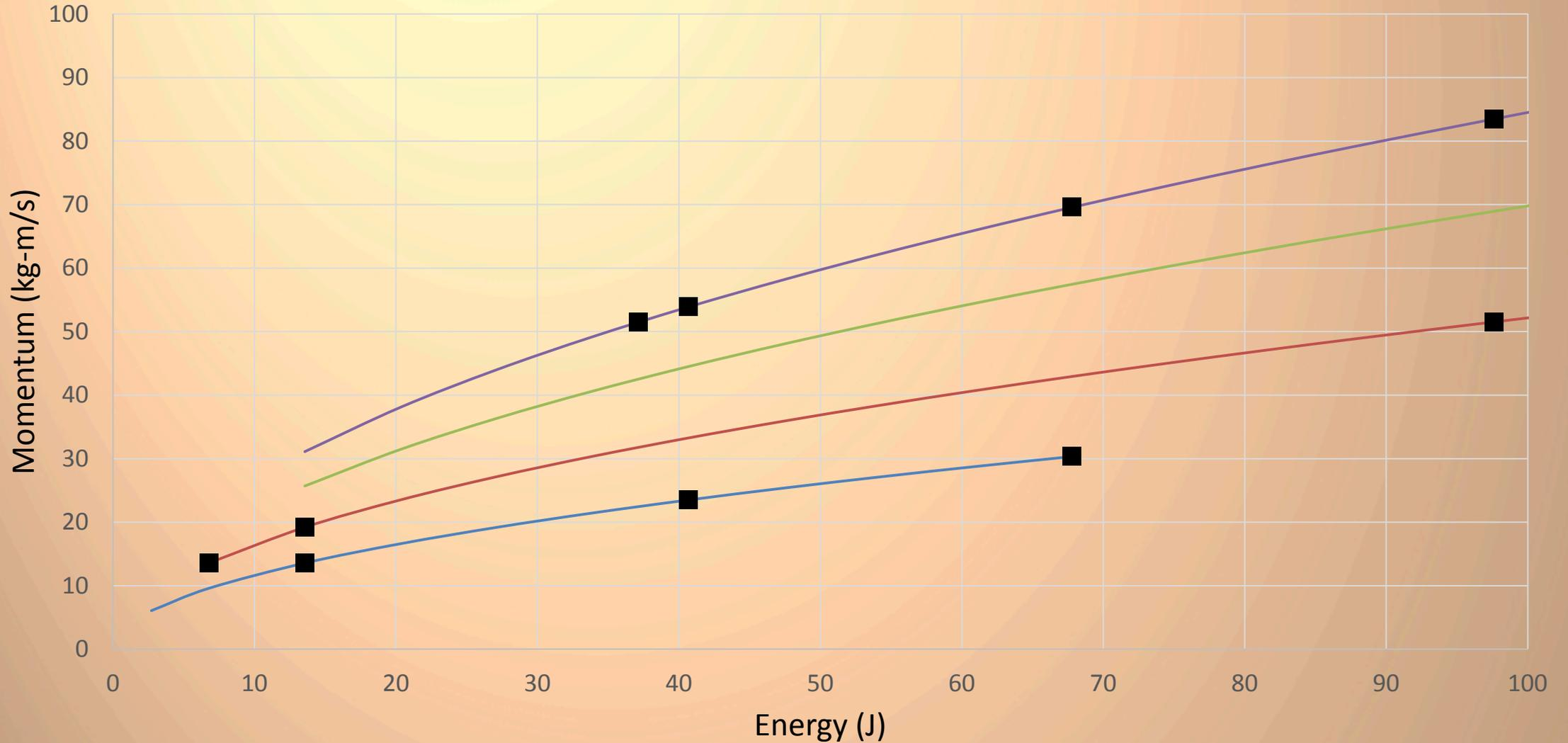

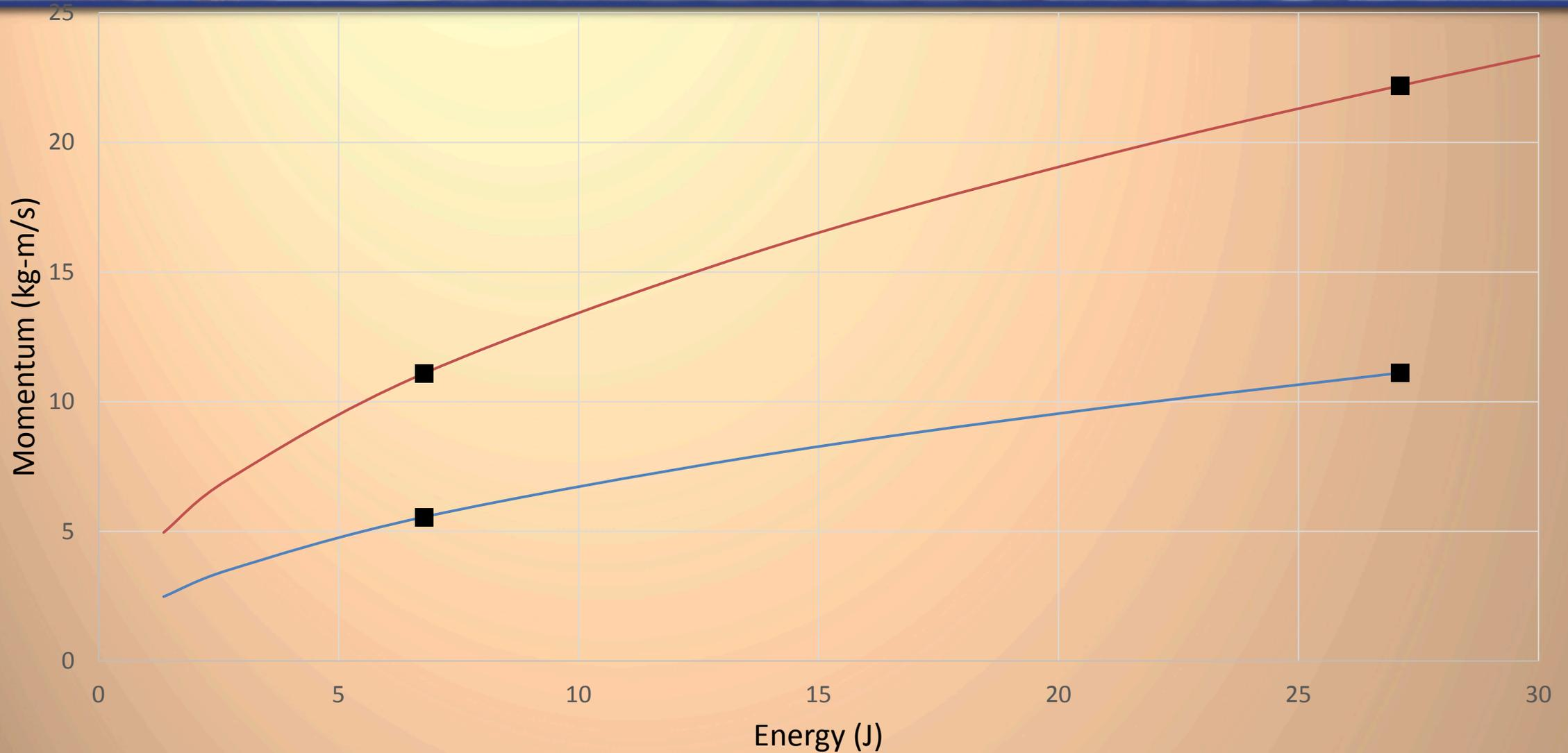

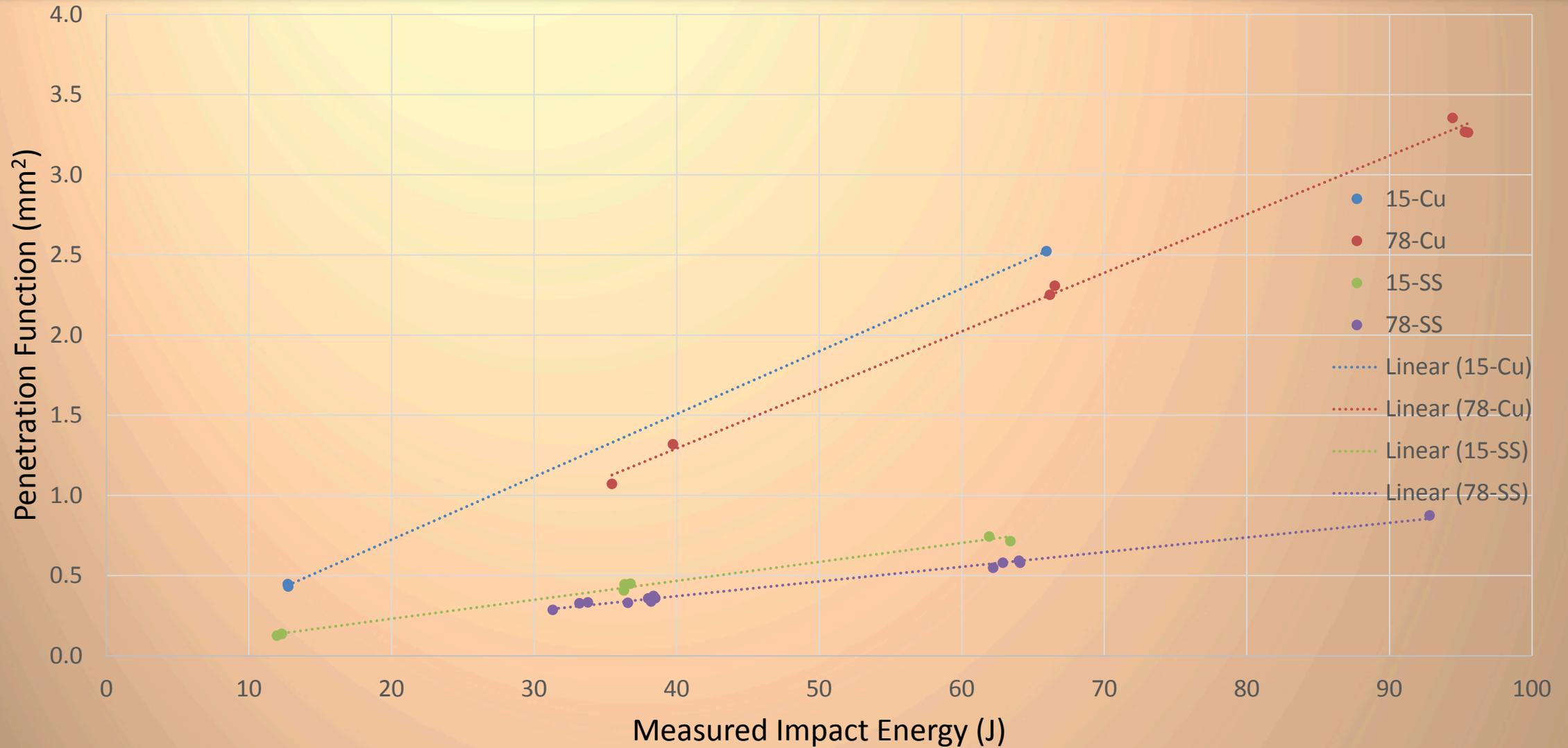

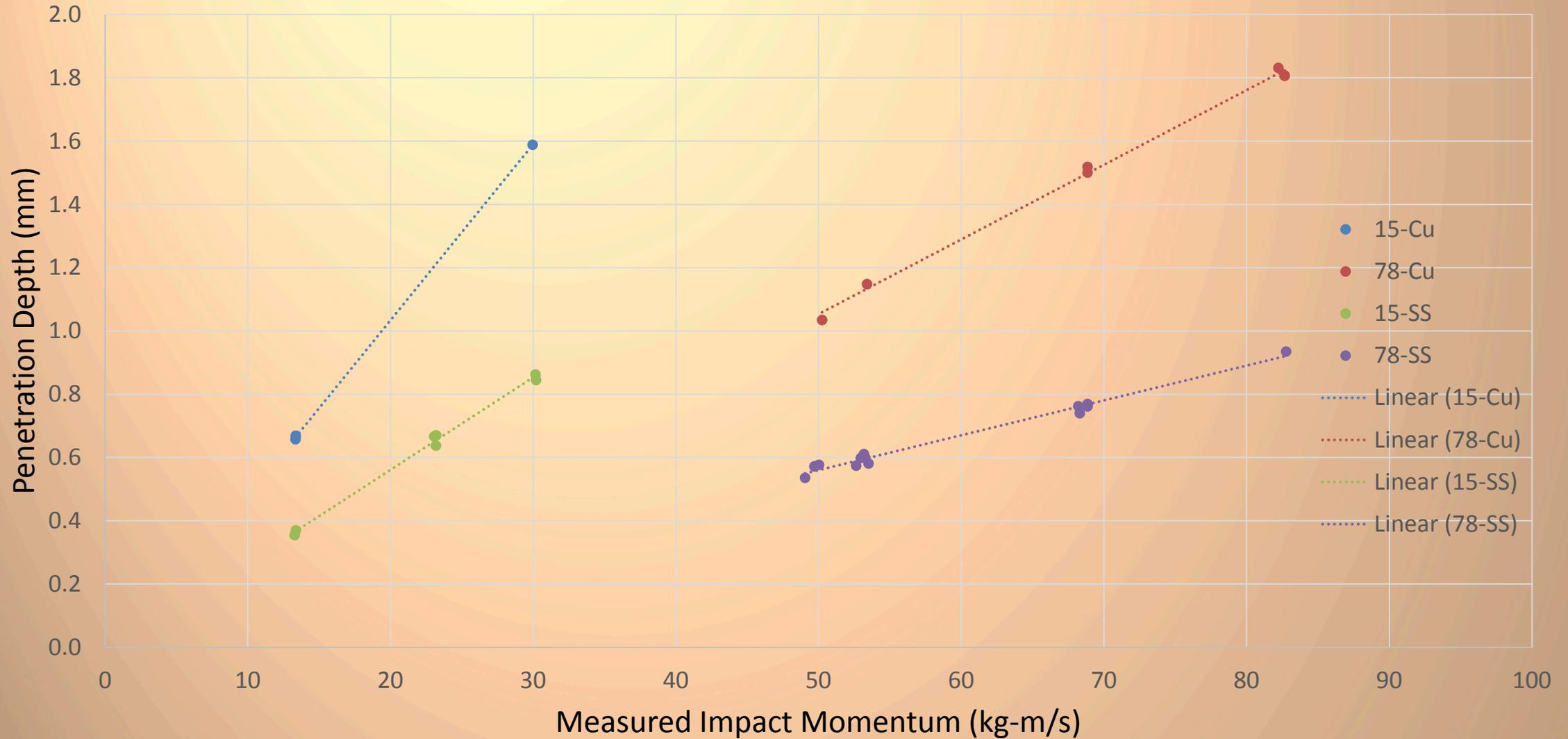

Results

Energy (J)	Momentum (kg-m/s)	Mass (kg)	Drop Height (m)	Material	Peak Load (N)	Impact Velocity (m/s)	Impact Duration (ms)	Impact Energy (J)	Impact Momentum (kg-m/s)	Average Power (kW)	Impulse (kg-m/s)	Dent Diameter (mm)	Penetration Depth (mm)	Penetration Function (mm ²)
67.8	30.3	6.78	1.02	Cu	40417	4.42	1.25	65.93	29.96	52.7	32.4	8.4023	1.0350	2.5230
67.8	69.6	35.67	0.194	Cu	41593	1.93	3.09	66.35	68.84	21.5	77.9	8.2207	1.0918	2.2797
40.7	23.5	6.78	0.612	SS	56117	3.41	0.96	36.47	23.14	38.0	29.7	5.6312	1.8196	0.4338
40.7	53.9	35.67	0.116	SS	50603	1.49	2.50	37.94	53.12	15.2	65.9	5.3579	1.8071	0.3516
67.8	30.3	6.78	1.02	SS	72614	4.45	0.95	62.67	30.19	66.0	38.1	6.3614	1.8065	0.7295
67.8	69.6	35.67	0.194	SS	65071	1.92	2.45	63.30	68.55	25.8	84.3	6.0185	0.3705	0.5752

Results

Energy (J)	Momentum (kg-m/s)	Mass (kg)	Drop Height (m)	Material	Peak Load (N)	Impact Duration (ms)	Impact Energy (J)	P-Value	Impact Momentum (kg-m/s)	P-Value	Average Power (kW)	P-Value	Penetration Function (mm ²)	P-Value
67.8	30.3	6.78	1.02	Cu	40417	1.25	65.93	0.253	29.96	---	52.7	0.0095	2.5230	0.0721
67.8	69.6	35.67	0.194	Cu	41593	3.09	66.35		68.84		21.5		2.2797	
40.7	23.5	6.78	0.612	SS	56117	0.96	36.47	0.022	23.14	6.04e-12	38.0	2.33e-7	0.4338	0.0012
40.7	53.9	35.67	0.116	SS	50603	2.50	37.94		53.12		15.2		0.3516	
67.8	30.3	6.78	1.02	SS	72614	0.95	62.67	0.486	30.19	1.29e-8	66.0	5.96e-7	0.7295	0.0008
67.8	69.6	35.67	0.194	SS	65071	2.45	63.30		68.55		25.8		0.5752	

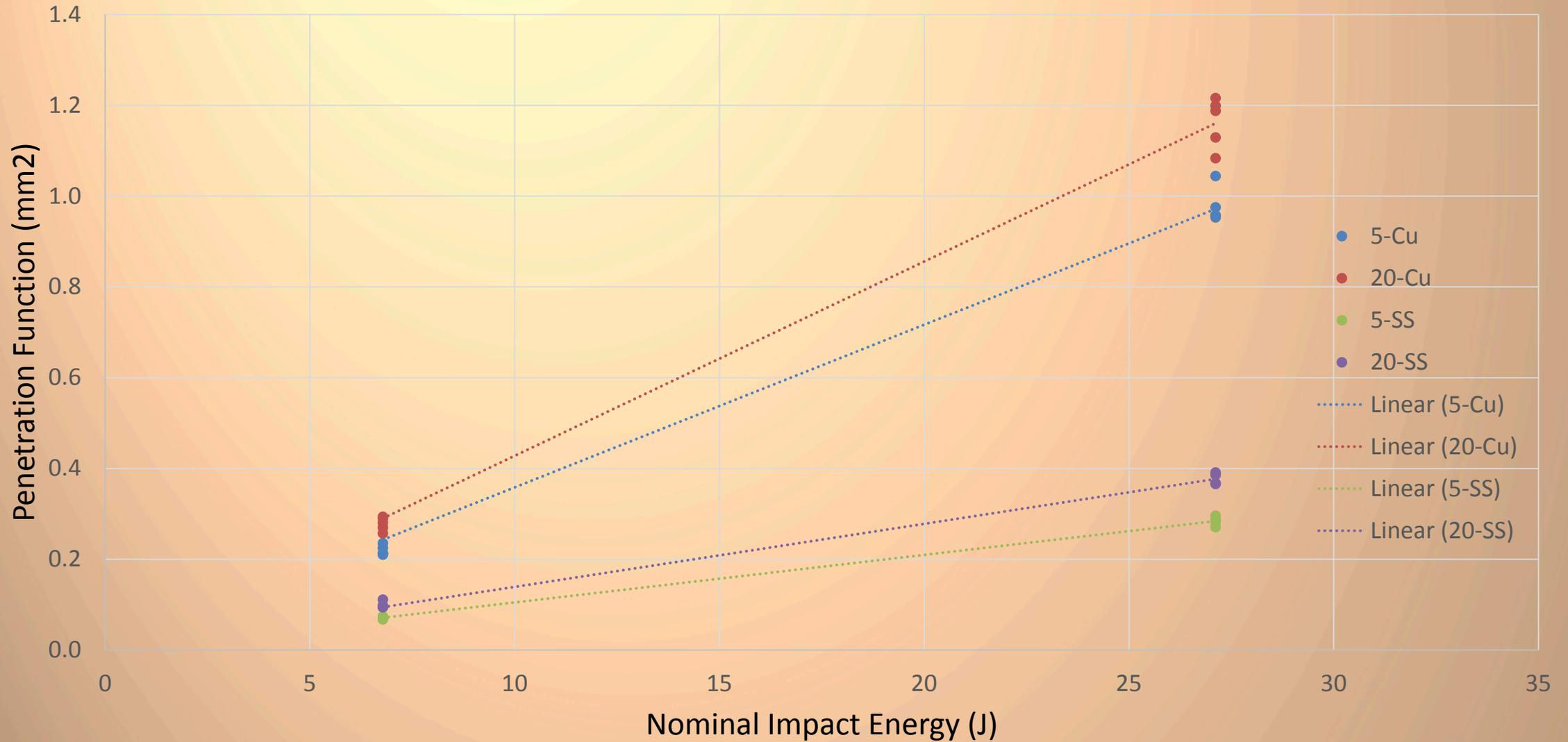

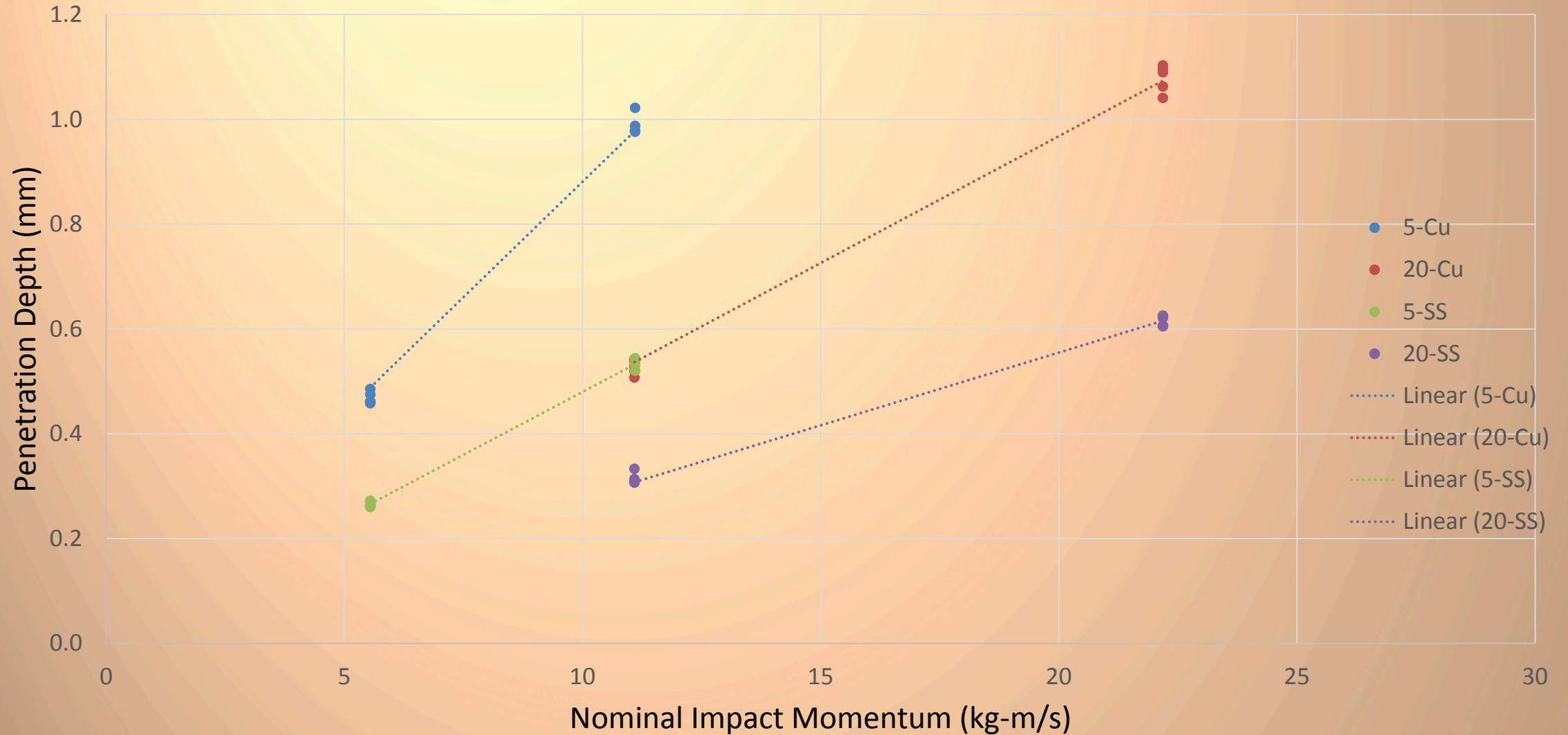

Results

Nominal Energy (J)	Nominal Momentum (kg-m/s)	Mass (kg)	Material	Penetration Depth (mm)	Penetration Function (mm ²)	P-Value
6.78	5.55	2.275	Cu	0.4682	0.2193	7.77e-6
6.78	11.09	9.068	Cu	0.5273	0.2782	
27.12	11.11	2.275	Cu	0.9885	0.9774	2.31e-5
27.12	22.18	9.068	Cu	1.0783	1.1632	
6.78	5.55	2.275	SS	0.2659	0.0707	2.62e-6
6.78	11.09	9.068	SS	0.3139	0.0986	
27.12	11.11	2.275	SS	0.5333	0.2845	1.25e-7
27.12	22.18	9.068	SS	0.6128	0.3757	

Discussion - Materials

Parameter	304 Stainless Steel	110 Copper
Hardness	96.8 HRB	41.1 HRB
Dent Size	Smaller	Larger
Energy Delivery	Slightly Less	Slightly More
Power	More	Less

Discussion - Systems

Non-Standard Instrumented System

- Heavier weight made smaller dent
- More momentum made larger dent
- Less rigid base
- Lighter weight impact happens faster – no time for structure to flex?

Standard Ambient System

- Heavier weight made larger dent
- More momentum made larger dent
- More rigid base
- Minimal structural flexing on either time scale

Discussion – Important Parameters

- Energies matched, but clear differences in impact
 - Power
 - Impulse
- Presumably power affects reactivity
- Two-parameter (or more) problem?

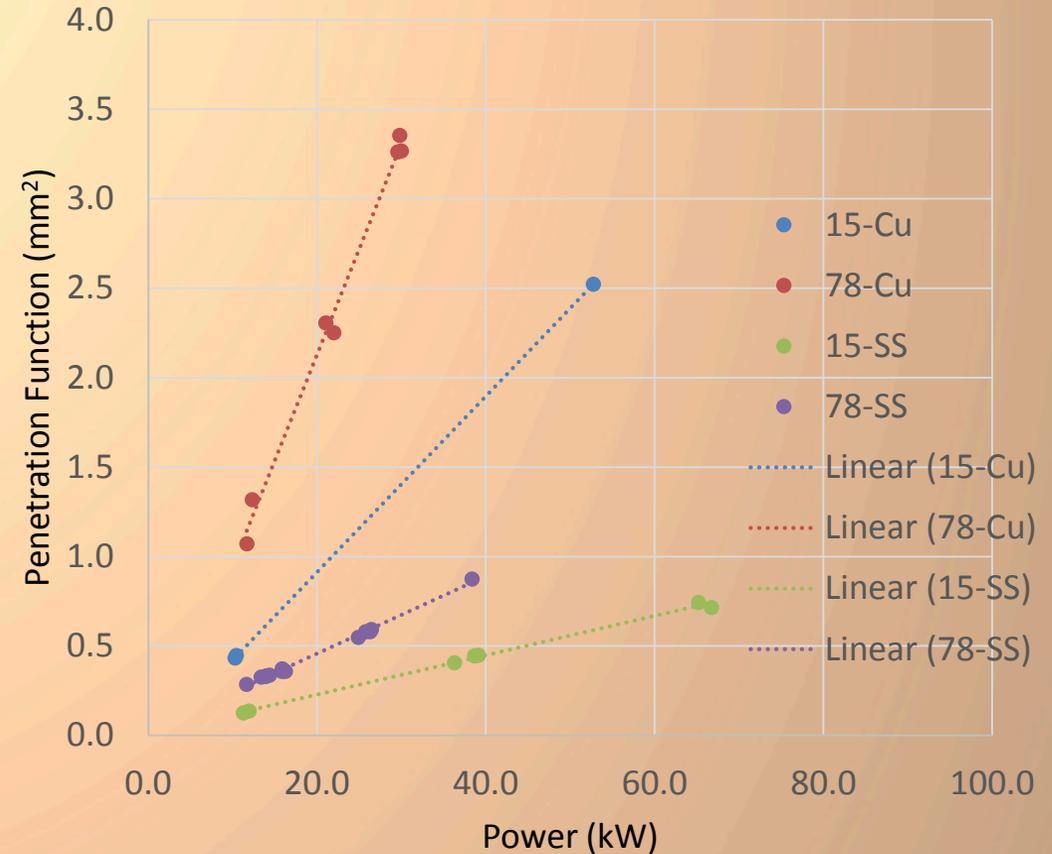

Discussion – Important Parameters

- Energies matched, but clear differences in impact
 - Power
 - Impulse
- Presumably power affects reactivity
- Two-parameter (or more) problem?

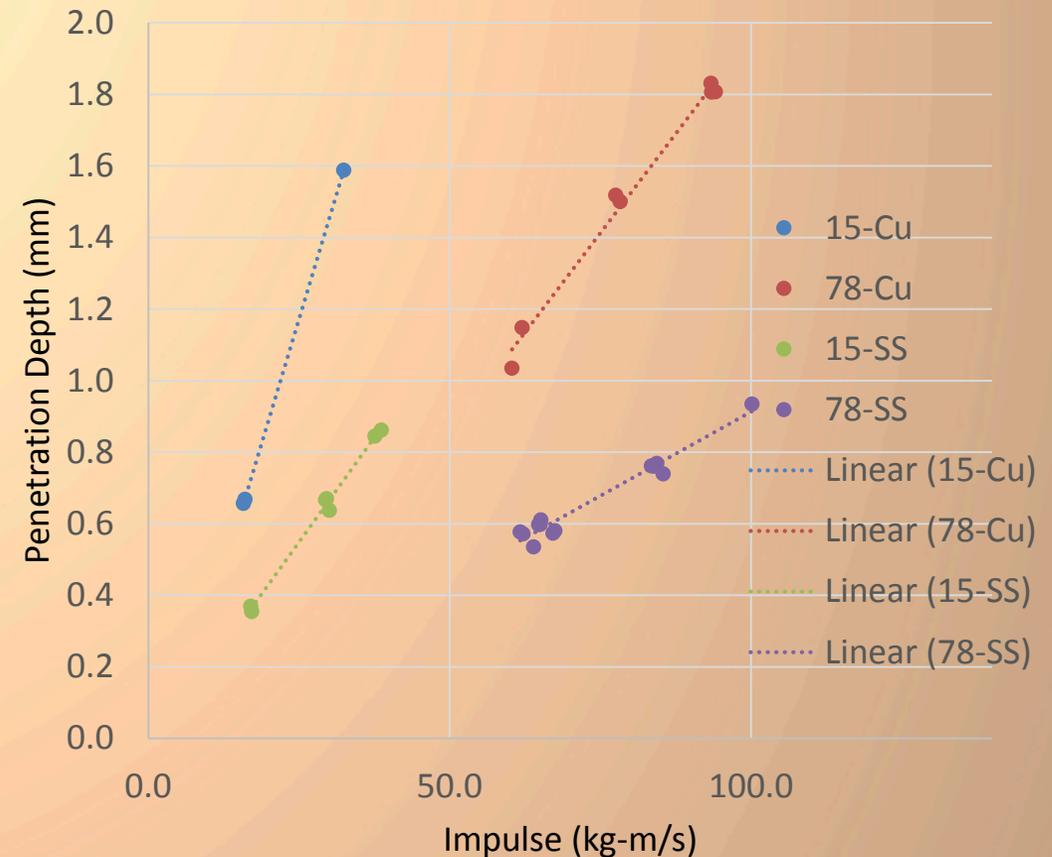

Discussion – Important Parameters

- Energies matched, but clear differences in impact
 - Power
 - Impulse
- Presumably power affects reactivity
- Two-parameter (or more) problem?

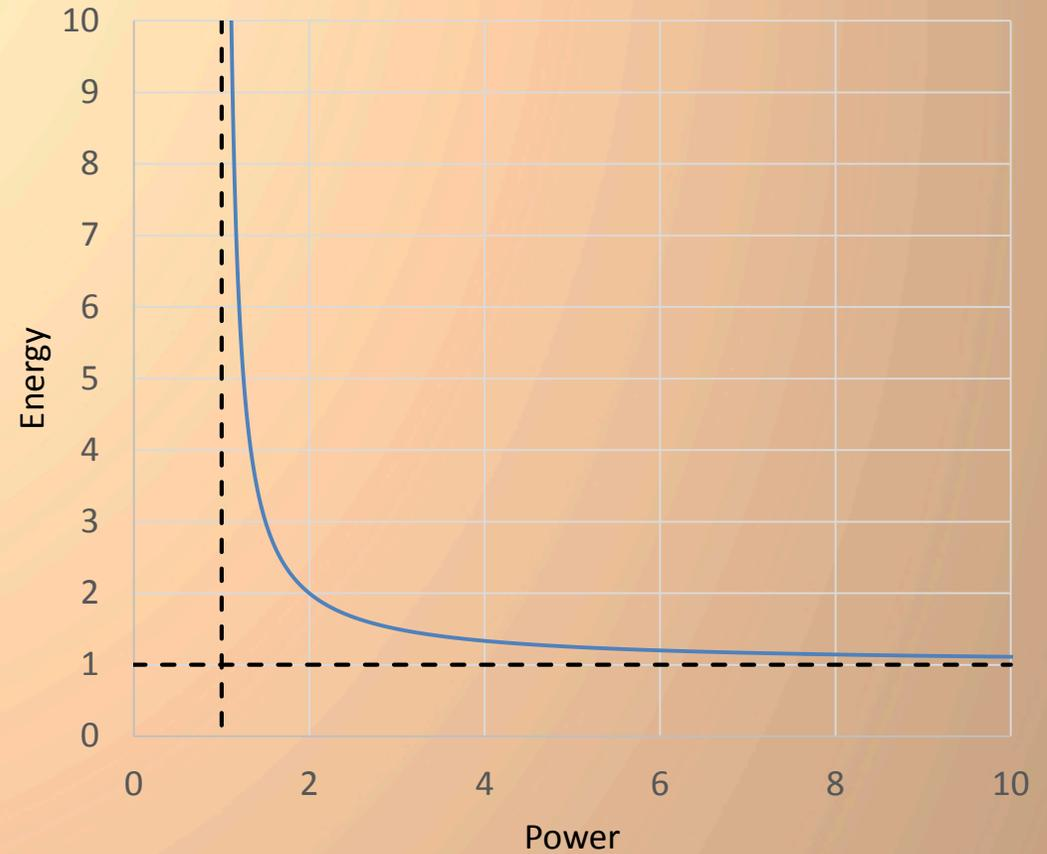

Conclusions and Future Work

- Softer dent blocks may offer increased resolution
- Comparison of different systems is extremely complicated
- Energy alone may not adequately characterize impacts

- More work needed to understand Power and Impulse
- Introduce controlled losses and attempt to compensate
- Test materials in oxygen

Results

Energy (J)	Momentum (kg-m/s)	Mass (kg)	Material	Peak Load (N)	Impact Velocity (m/s)	Impact Duration (ms)	Impact Energy (J)	Impact Momentum (kg-m/s)	Dent Diameter (mm)	Penetration Depth (mm)	Penetration Function (mm ²)	Average Power (kW)	Impulse (kg-m/s)
13.6	13.6	6.78	Cu	22942	1.97	1.23	12.74	13.35	5.6515	0.6634	0.4401	10.4	15.9
37.1	51.5	35.67	Cu	33533	1.41	3.04	35.45	50.25	6.9494	1.1231	1.0713	11.7	60.3
40.7	53.9	35.67	Cu	33728	1.50	3.23	39.74	53.40	7.2847	1.5884	1.3190	12.3	62.0
67.8	30.3	6.78	Cu	40417	4.42	1.25	65.93	29.96	8.4023	1.0350	2.5230	52.7	32.4
67.8	69.6	35.67	Cu	41593	1.93	3.09	66.35	68.84	8.2207	1.0918	2.2797	21.5	77.9
97.6	83.5	35.67	Cu	47090	2.31	3.19	95.08	82.51	8.8900	1.3337	3.2952	29.8	93.6
13.6	13.6	6.78	SS	30807	1.96	1.05	12.13	13.33	4.2304	1.5098	0.1316	11.6	17.1
37.1	51.5	35.67	SS	49090	1.39	2.53	32.76	49.59	5.2214	1.6660	0.3158	13.0	62.6
40.7	23.5	6.78	SS	56117	3.41	0.96	36.47	23.14	5.6312	1.8196	0.4338	38.0	29.7
40.7	53.9	35.67	SS	50603	1.49	2.50	37.94	53.12	5.3579	1.8071	0.3516	15.2	65.9
67.8	30.3	6.78	SS	72614	4.45	0.95	62.67	30.19	6.3614	1.8065	0.7295	66.0	38.1
67.8	69.6	35.67	SS	65071	1.92	2.45	63.30	68.55	6.0185	0.3705	0.5752	25.8	84.3
97.6	83.5	35.67	SS	77856	2.32	2.42	92.82	82.77	6.6345	0.3627	0.8749	38.4	100.1