



Marshall Grazing Incidence

Ken Kobayashi¹, Amy Winebarger¹, Sabrina Savage¹, Patrick Champey¹,
Peter Cheimets², Edward Hertz², Alexander Bruccoleri³, Jorg Scholvin³, Leon
Golub², Brian Ramsey¹, Jaganathan Ranganathan¹, Vanessa Marquez², Ryan
Allured², Theodore Parker², Ralf Heilmann⁴, Mark Schattenburg⁴

1: NASA Marshall Space Flight Center

2: Smithsonian Astrophysical Observatory

3: Izentis LLC

4: Massachusetts Institute of Technology

Background

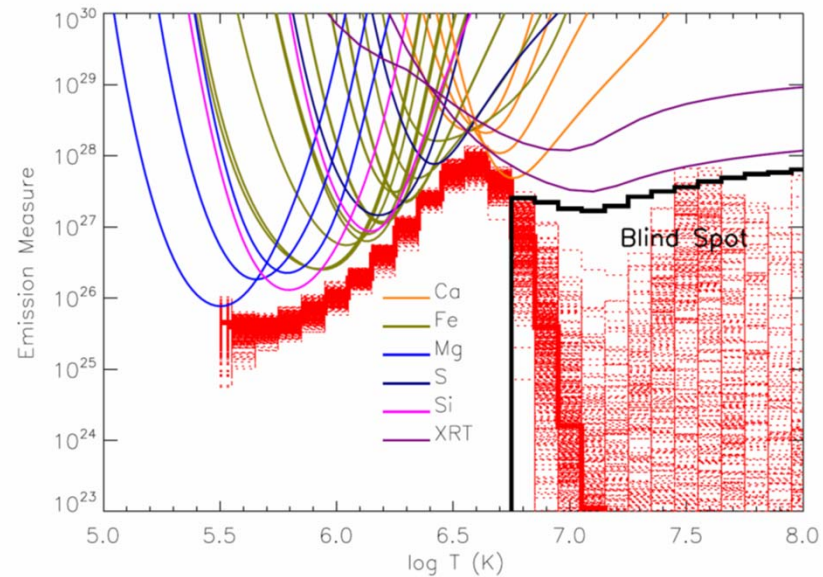

- Science Goals:
 - Measure the temperature distribution (Differential Emission Measure) of the solar corona to better understand the coronal heating mechanism
 - Measure the elemental abundance in the solar corona

Observation Goals

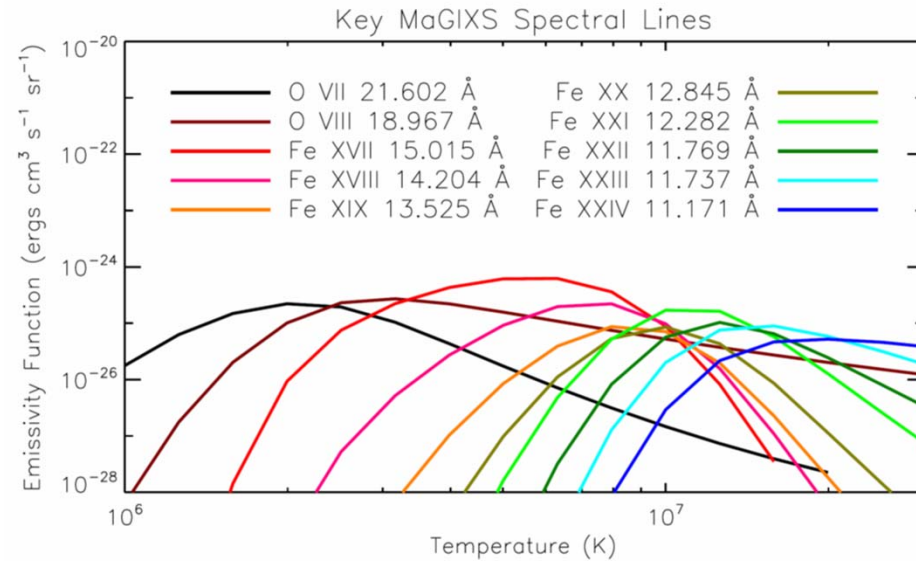

- Observation Goals:
 - Energy range: 0.57 – 1.3 keV (0.91 – 2.16 nm)
 - Energy resolution: ~1 eV (0.005 nm)
 - Slit spectrograph with 260" slit length
 - 6" spatial resolution along slit

Optical Design

(Al/mesh pre-filter not shown)

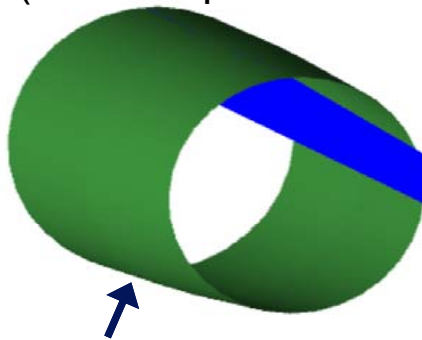

Wolter-I Telescope:

- Focal length = 1090 mm
- Full length = 250 mm
- Diameter = 150 mm
- Graze angle = 1.0°

Paraboloid Mirror x2
(collimating & reimaging)

- Focal length = 600 mm
- Shell length = 80mm
- Graze angle = 2.0°

slit

Al/Polyimide filter +
2k x 1k frame-transfer
CCD

Grating:

- Planar, 25 mm x 73 mm
- 1850 – 2500 lines/mm

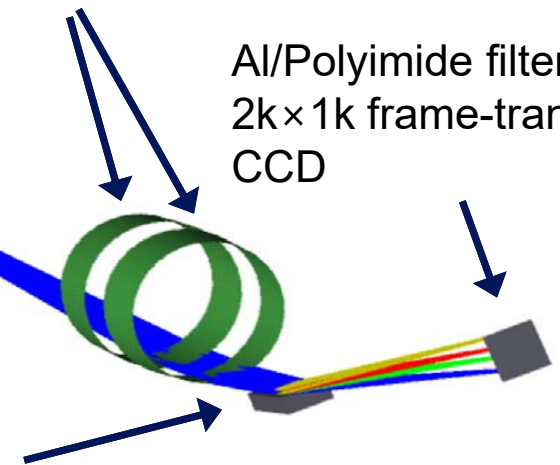



Instrument Layout

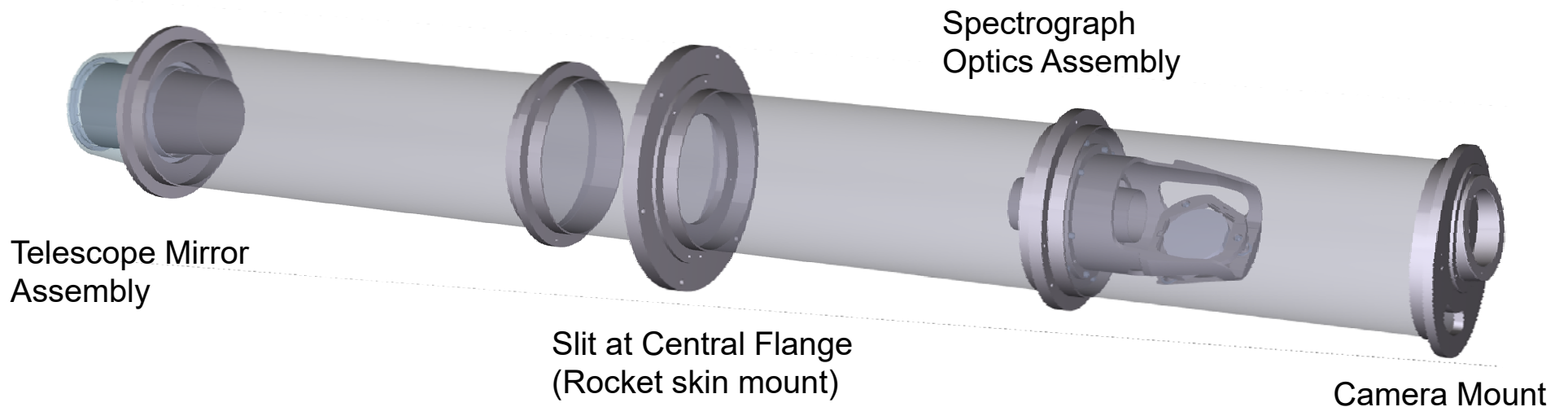



Instrument Structure

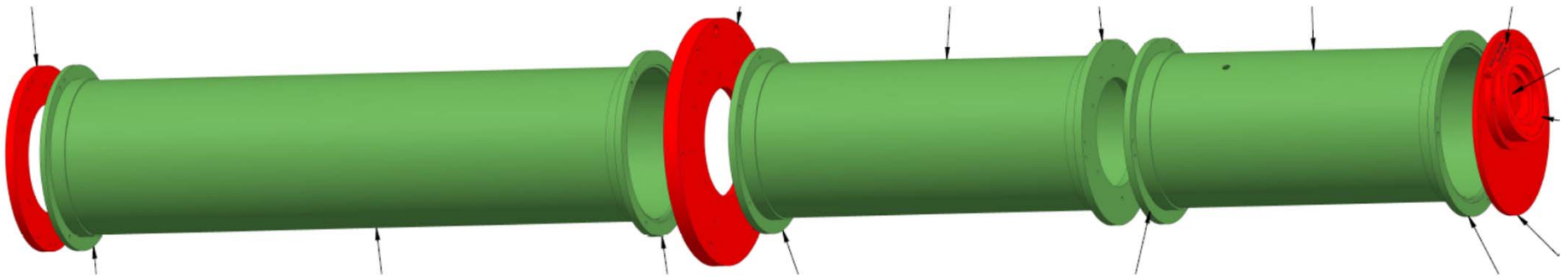

- Structure is cantilevered from central flange
- Stainless steel tubing with welded & machined flanges for low cost & acceptable thermal stability



Telescope Mirror Assembly

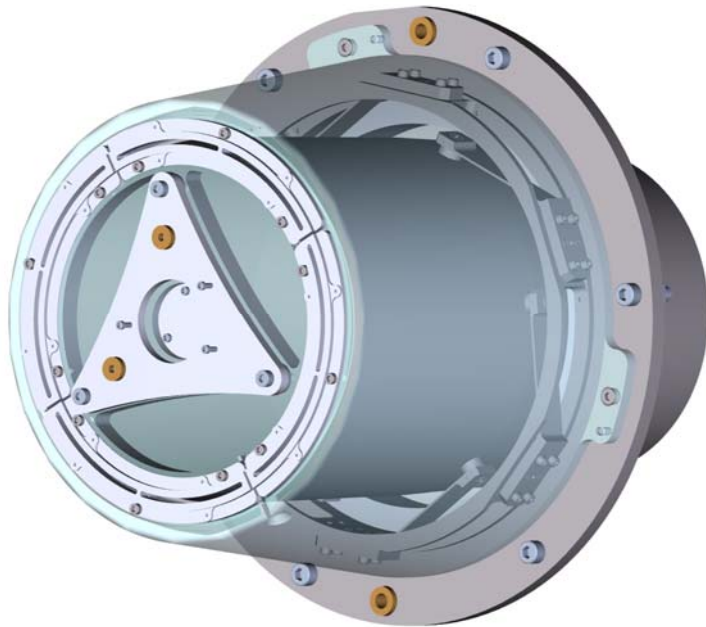

Telescope Mirror Assembly:

- Sun sensor mount
- Pre-filters (Al on mesh); light tight design
- Telescope mirror supported at CG by 6 flexures
- Alignment features (centering reticle and optical flat)
- Mirror aligned to optical flat with CDA (centroid detector assembly) before bonding
- Hardware delivery expected in September.



Spectrograph Optics Assembly

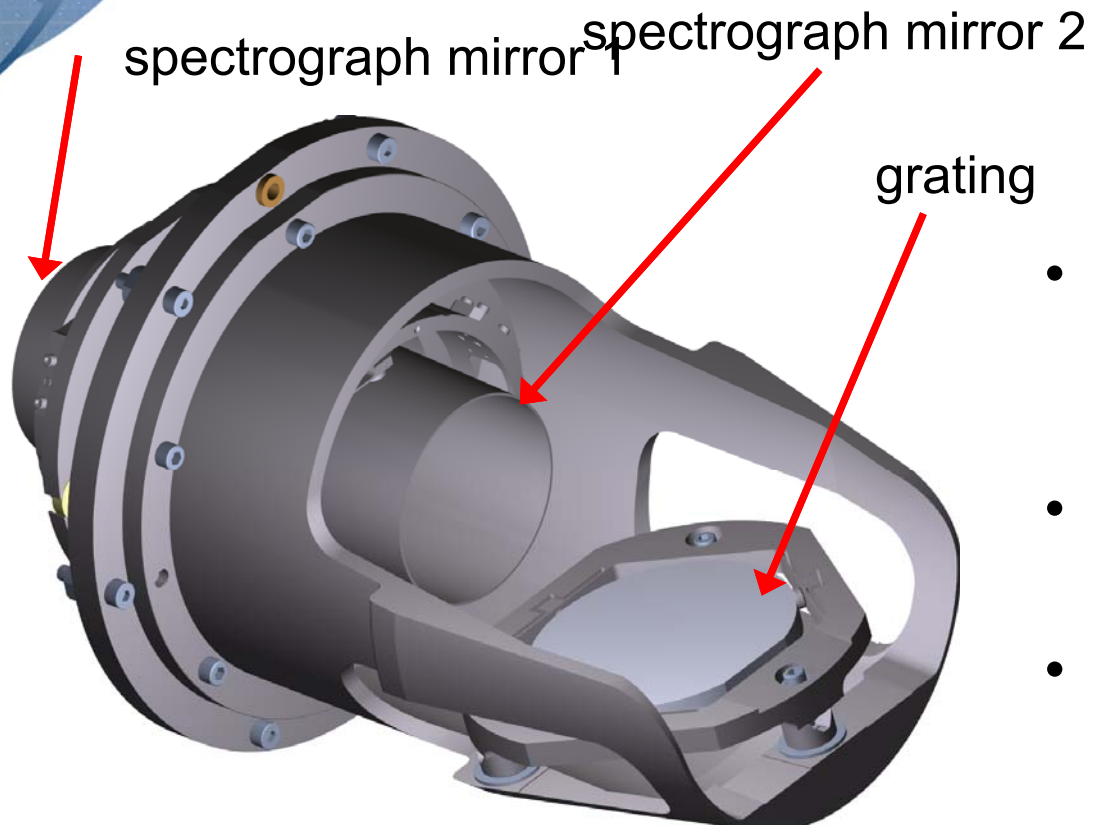

- Spectrograph mirror pair aligned to each other optically to ~6" and bonded
- Mirrors aligned to centering reticle & reference flat
- Kinematic grating mount



Mirrors

- Electroformed nickel replicated mirrors, fabrication at NASA MSFC, based on heritage from FOXSI, HERO, ART-XC, etc
- Unique challenges:
 - Short focal length, long segment length
 - High resolution requirement (<6 arcsec half power diameter)
- Status:
 - Machining completed on both mandrels
 - Hand polishing and lapping of both mandrels completed
 - Test mirror shells replicated & tested in X-ray
 - Further mandrel polishing using Zeeko polisher underway





Mirrors

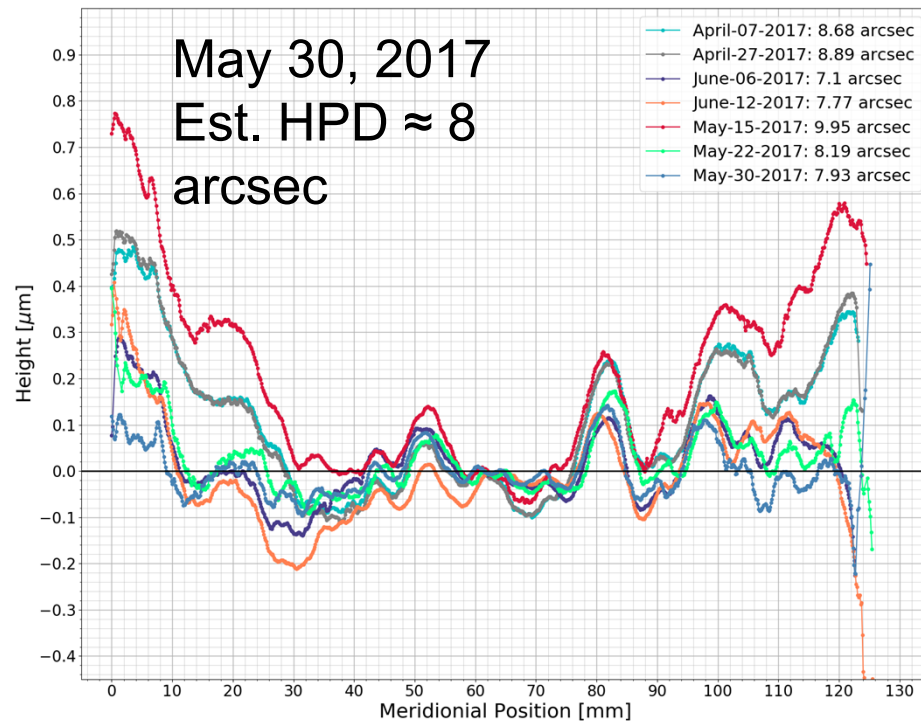



Grating

- Planar grating with varied line spacing
- Challenges:
 - Blazed grating required for good efficiency at grazing incidence
 - Large variation in line spacing (398nm to 541nm over 73mm) precludes use of holographic grating
- Electron-beam lithography + etching to be used
- Grating substrate is crystalline silicone with the {111} crystal orientation matched to the desired blaze angle
- KOH etching, with {111} plane of crystal acting as etch stop
- Substrate procured; fabrication preparation underway at Izentis LLC

Camera

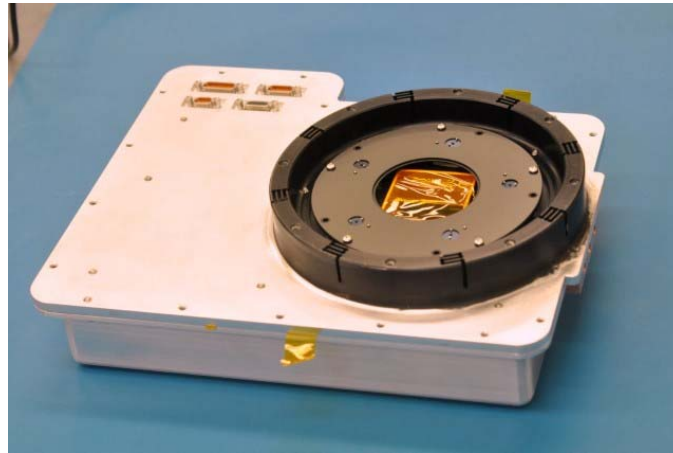

- Custom designed at MSFC, originally for the High Resolution Coronal Imager 2 (Hi-C II).
- e2v CCD230 – 2k x 2k full-frame / 2k x 1k frame-transfer (frame-transfer mode for MaGIXS)
- Flight heritage from Hi-C (used in full frame mode)
- 6 e- rms noise demonstrated at 500 kpixel/s readout speed
- CCD connected to LN2-cooled thermal reservoir; <-30C temperature to be maintained for flight
- Data transfer through SpaceWire to flight computer for control onboard image storage & downlink



Status

- Major instrument structures in fabrication
- Mirror mandrels in polishing