

Chapter 1

Electra: A Modular-Based Expansion of NASA’s Supercomputing Capability

Rupak Biswas

NASA Ames Research Center

Jeff Becker, Davin Chan, David Ellsworth, Robert Hood

CSRA LLC—NASA Ames Research Center

Piyush Mehrotra

NASA Ames Research Center

Michelle Moyer, Chris Tanner

CSRA LLC—NASA Ames Research Center

William Thigpen

NASA Ames Research Center

1.1	Introduction	2
1.2	NASA Requirements for Supercomputing	3
1.3	Supercomputing Capabilities: Conventional Facilities	4
1.3.1	Computer Systems	4
1.3.2	Interconnect	5
1.3.3	Network Connectivity	6
1.3.4	Storage Resources	6
1.3.5	Visualization and hyperwall	7
1.3.6	Primary NAS Facility	8
1.4	Modular Supercomputing Facility	9
1.4.1	Limitations of the Primary NAS Facility	9
1.4.2	Expansion and Integration Strategy	9
1.4.3	Site Preparation	10
1.4.4	Module Design	10
1.4.5	Power, Cooling, Network	11
1.4.6	Facility Operations and Maintenance	13
1.4.7	Environmental Impact	14
1.5	Electra Supercomputer	15
1.5.1	Performance	16
1.5.2	I/O Subsystem Architecture	16

1.6	User Environment	17
1.6.1	System Software	17
1.6.2	Resource Allocation and Scheduling	17
1.6.3	User Services	18
1.7	Application Benchmarking and Performance	18
1.8	Utilization Statistics of HECC Resources	21
1.9	System Operations and Maintenance	23
1.9.1	Administration Tools	24
1.9.2	Monitoring, Diagnosis, and Repair Tools	24
1.9.3	System Enhancements and Maintenance	25
1.10	Featured Application	25
1.11	Conclusions	28
	Acknowledgments	29
	Bibliography	29

1.1 Introduction

NASA has increasingly relied on high-performance computing (HPC) resources for computational modeling, simulation, and data analysis to meet the science and engineering goals of its missions in space exploration, aeronautics, and Earth and space science. The NASA Advanced Supercomputing (NAS) Division at Ames Research Center in Silicon Valley, Calif., hosts NASA’s premier supercomputing resources, integral to achieving and enhancing the success of the agency’s missions. NAS provides a balanced environment, funded under the High-End Computing Capability (HECC) project, comprised of world-class supercomputers, including its flagship distributed-memory cluster, Pleiades; high-speed networking; and massive data storage facilities, along with multi-disciplinary support teams for user support, code porting and optimization, and large-scale data analysis and scientific visualization.

However, as scientists have increased the fidelity of their simulations and engineers are conducting larger parameter-space studies, the requirements for supercomputing resources have been growing by leaps and bounds. With the facility housing the HECC systems reaching its power and cooling capacity, NAS undertook a prototype project to investigate an alternative approach for housing supercomputers. Modular supercomputing, or container-based computing, is an innovative concept for expanding NASA’s HPC capabilities. With modular supercomputing, additional containers—similar to portable storage pods—can be connected together as needed to accommodate the agency’s ever-increasing demand for computing resources. In addition, taking advantage of the local weather permits the use of cooling technologies that would additionally save energy and reduce annual water usage.

The first stage of NASA’s Modular Supercomputing Facility (MSF) prototype, which resulted in a 1,000 square-foot module on a concrete pad with

room for 16 compute racks, was completed in Fall 2016 and an SGI (now HPE) computer system, named Electra, was deployed there in early 2017. Cooling is performed via an evaporative system built into the module, and preliminary experience shows a Power Usage Effectiveness (PUE) measurement of 1.03. Electra achieved over a petaflop on the LINPACK benchmark, sufficient to rank number 96 on the November 2016 TOP500 list [14]. The system consists of 1,152 InfiniBand-connected Intel Xeon Broadwell-based nodes. Its users access their files on a facility-wide filesystem shared by all HECC compute assets via Mellanox MetroX InfiniBand extenders, which connect the Electra fabric to Lustre routers in the primary facility over fiber-optic links about 900 feet long. The MSF prototype has exceeded expectations and is serving as a blueprint for future expansions.

In the remainder of this chapter, we detail how modular data center technology can be used to expand an existing compute resource. We begin by describing NASA's requirements for supercomputing and how resources were provided prior to the integration of the Electra module-based system.

1.2 NASA Requirements for Supercomputing

NASA's research-oriented science and aeronautics projects rely on very large-scale, high-fidelity simulations to advance the understanding of a broad spectrum of topics, such as Earth's weather and climate, galaxy formation, solar magnetic fields, and complex aircraft aerodynamics. Some of these intensive simulations require system capabilities that can handle long-running computations using upwards of 70,000 cores each, utilizing a sizable portion (25% or more) of the system at one time. The system must also support more than 1,500 users and be able to run hundreds of jobs simultaneously; individual jobs must not adversely affect the performance of other jobs that are also being executed. In addition, NASA's engineering-oriented efforts, such as launch and crew exploration vehicle development, often require high-throughput system capacities to rapidly process large sets of moderate-scale computations—typically, 500–4,000 cores each—in order to analyze a wide range of flight conditions and vehicle design variations.

The high demand for compute resources and the need to meet mission critical deadlines mean that any downtime related to maintenance activities must be minimized. High availability is also required for time-sensitive, mission-critical analyses that can be performed on demand—for example, immediate analyses of anomalous events during space missions, such as debris strikes, or timely weather prediction analyses that can aid preparations for dangerous storms.

NASA's HECC users run more than 1000 applications covering various programming paradigms and languages, and numerous classes of algorithms,

data structures, and communication/memory access patterns. Of these, 12 applications are responsible for approximately 50% of the resource usage. The performance of these key applications—used heavily in aerospace vehicle design and Earth and space sciences research—must be taken into careful consideration when selecting system and processor types, hardware architectures, storage and filesystems configurations, and so on. In addition, to handle an increasing and evolving workload over time, the system must be expandable while still providing a consistent user interface over its lifetime.

Collectively, these diverse NASA project needs, analysis applications, and access requirements drive many of the key decisions to procure, configure, and regularly upgrade the agency's supercomputing systems. In the next section, we describe the capability into which the new MSF and Electra system were integrated.

1.3 Supercomputing Capabilities: Conventional Facilities

1.3.1 Computer Systems

Prior to deploying the MSF, the NAS supercomputing resources comprised four platforms, all manufactured by SGI (now HPE):

- Pleiades: NASA's flagship supercomputer, a distributed-memory cluster containing four generations of Intel processors (described in more detail below).
- Endeavour: A shared-memory, single system image (SSI) computer that replaced the Columbia SSI cluster, which was the predecessor to Pleiades.
- Merope: A system containing older processor nodes removed from Pleiades to accommodate its expansion, located about a mile from the main NAS facility.
- hyperwall: A 128-node visualization cluster with a wall of 128 screens arranged in an 8x16 configuration.

The initial deployment of Pleiades, in 2008, comprised 100 racks with 12,800 quad-core Intel Xeon E5472 (Harpertown) processors. At 487 teraflops (TF) (LINPACK), it was the third-most powerful supercomputer in the world at that time. Subsequent expansions added Intel X5570 (Nehalem), X5670 (Westmere), E5-2760 (Sandy Bridge), E5-2680v2 (Ivy Bridge), E5-2680v3 (Haswell), and E5-2680v4 (Broadwell) multi-core processors. Currently, Pleiades comprises 160 racks (11,440 nodes) containing Sandy Bridge,

Ivy Bridge, Haswell, and Broadwell processors, and is ranked 15th in the world at 5.95 petaflops (LINPACK). [13]

As Pleiades has grown, racks that were removed to accommodate the new ones were repurposed into a smaller cluster, Merope, situated in a remote building approximately one mile from the primary NAS facility. [10] Currently, Merope consists of 56 half-populated racks containing 1,792 Westmere compute nodes. Merope is connected to Pleiades through a long-distance InfiniBand network that also allows it to share storage with the other NAS systems. This storage-sharing architecture is important to note, as it provides the basis for a similar scheme used between Pleiades and the MSF. The architecture is described in more detail below.

1.3.2 Interconnect

A Pleiades rack consists of four individual rack units (IRUs), each split into two halves. Each half-IRU has nine compute nodes connected to a single Fourteen Data Rate (FDR) InfiniBand (IB) switch. Because each node has two IB ports—either a dual-port host-channel adapter (HCA) or two single-port HCAs—the second port is connected to a separate IB switch on a second plane. The first IB plane is used for MPI traffic, while the second plane is primarily used for I/O. Both planes are similar hypercubes, so we only describe the construction of the first plane.

Each IB switch is a vertex of a hypercube. The first dimension is built by connecting the two switches in each IRU. Neighboring IRUs are connected on the second dimension, followed by connections between the top IRU pair and the bottom IRU pair in each rack. Neighboring racks are connected on the fourth dimension, and so on. In total, the 160 racks of Pleiades are interconnected in a partial 12-dimension hypercube. Both IB planes are managed using the OpenSM subnet manager from Mellanox OFED. The subnet manager uses the dimension-order routing (DOR) algorithm to program the IB switch forwarding tables. This algorithm uses the Min Hop techniques to pick the shortest route and breaks ties by choosing the lowest-numbered dimension.

1.3.3 Network Connectivity

The NAS high-speed routed data network connects multiple components within the primary NAS facility and the external location containing Merope, but also provides system access to external users. Each month, users move hundreds of terabytes of data over this network that has three major elements: enclave, core, and border. The enclave directly connects the Pleiades compute systems and major subsystems, supporting the overall administrative and IT security requirements. The core provides high-speed Local Area Network (LAN) connectivity for users to access compute resources and services, as well as private networks for system administrators and public-facing networks such as web servers. This LAN has a 10-Gigabit Ethernet (GigE)

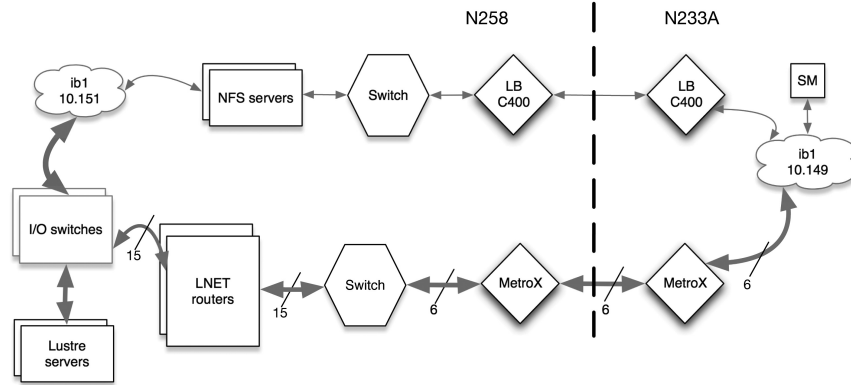

FIGURE 1.1: Components connecting Merope’s compute nodes in Building 233A to user filesystems in Building N258, the primary NAS facility.

backbone consisting of many subnets for NAS support functions. The border provides high-speed wide area network (WAN) connections to NASA networks and other partner sites for access by remote users. This advanced peering environment includes 10-GigE connectivity to the NASA Integrated Communications Services (NICS) backbone, and dedicated 10-GigE connectivity to the Jet Propulsion Laboratory and Goddard Space Flight Center.

1.3.4 Storage Resources

NAS provides both Network File System (NFS) storage for home filesystems and software packages, and high-performance Lustre filesystems for reading and writing from HPC jobs. [6] There are six Lustre filesystems, each with between 84 and 312 object storage targets (OSTs), providing a total storage pool of between seven and 19 petabytes (PB) per filesystem. Both the NFS and Lustre servers are connected via InfiniBand (QDR for NFS, FDR for Lustre) to a four-dimensional hypercube of 16 FDR IB switches. This torus has connections throughout Pleiades on the I/O plane, and also to Endeavour and the hyperwall. (Note that the I/O IB plane is a single InfiniBand subnet.) In order to permit DOR to route between three hypercubes—Pleiades, the I/O switch bank, and the hyperwall—NASA engineers worked with SGI (now HPE) to add weights to selective links in the fabric. Each weight (an integer > 1) multiplies the effective distance (number of hops) of the associated link. Since DOR favors shorter paths, this enables the routing to favor paths free of deadlock cycles.

Merope, located in the auxiliary NAS facility in Building 233A, also requires access to the NFS and Lustre filesystems in Building N258, the primary

facility. However, since it has its own compute and I/O subnets, a different connection method is required, as shown in Figure 1.1.

In the case of NFS, each server is connected to a QDR IB switch. The latter is then connected to an Obsidian Longbow InfiniBand Range Extender, which connects to a second Longbow next to Merope via approximately 1.2 miles of optical fiber. Finally, this Longbow connects to Merope's I/O plane to allow the sharing of NFS filesystems with Pleiades. For Lustre, several routers (called "LNET routers" in Figure 1.1), which have two IB ports, are used to bridge between Pleiades' I/O plane and Merope's. The Pleiades side of each Lustre router is connected to a Mellanox MetroX long-haul IB switch, which is connected via optical fiber to another MetroX switch that is situated next to Merope. The Lustre connection is completed by several connections between this MetroX switch and Merope's I/O plane.

In addition to the NFS and Lustre filesystems, NAS storage resources include a 525 PB tape system that enables reliable and secure archiving and rapid retrieval. User data is written to two separate tape media in silos located in different buildings. Data migration is managed via SGI's Data Migration Facility (DMF) and OpenVault.

The mass storage system, an SGI parallel DMF cluster with high-availability clustering software, consists of four 32-processor front-end systems with 64 gigabytes (GB) of memory each; 2.9 PB of locally attached SATA RAID Spectra Logic tape storage (525 PB maximum capacity with normal 35-percent compression); six TFinity tape libraries; and 92 LTO-7 tape drives.

1.3.5 Visualization and hyperwall

The NAS facility's hyperwall, shown in Figure 1.2, is composed of 128 nodes containing NVIDIA GeForce GTX 780 Ti graphics processing units (GPUs) and Intel Xeon Ivy Bridge processor cores, connected to 128 tiled LCD display screens arranged in a wall measuring 23 feet wide by 10 feet high. It has a peak processing power of 57 TF, and directly accesses the NAS facility's online disk storage. [8]

The NAS-developed concurrent visualization framework enables realtime graphical processing and display on the hyperwall while applications are running. This capability is needed to support the visualization of very large datasets that are challenging to store, transfer, and view in their entirety, and provides results that are immediately available for analysis. The framework also enables animations to be rendered and stored showing every time step in the simulation, which allows researchers to see rapid processes in their models—often for the first time—and identify computational problems or optimize parameters on the fly. Production data can be transferred live from the supercomputer to the hyperwall without slowing code performance. A new interactive data analysis tool for the hyperwall, recently developed by the NAS Visualization and Data Analysis team, is described in Section 1.10.

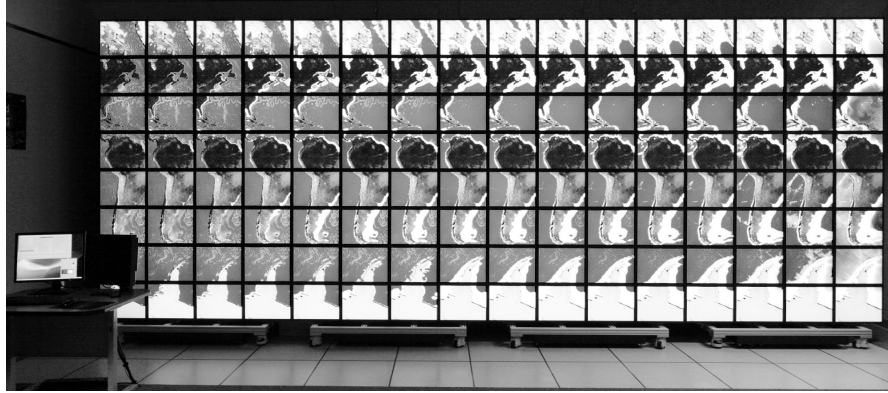

FIGURE 1.2: The 128-screen hyperwall, showing part of a visualization of a global ocean circulation simulation (described in Section 1.10).

1.3.6 Primary NAS Facility

Constructed in 1985, the primary NAS facility at NASA Ames Research Center is a steel-frame two-story structure with steel-reinforced concrete floor, built to sustain shear loads consistent with the force of a magnitude 8.0+ earthquake. The raised floor includes 15,000 square feet of primary computer floor.

The facility's chiller system has a capacity of 1,800 tons and is capable of achieving a water temperature of 42°F. An intricate plumbing topology and a pumping system able to sustain flow rates in excess of 4000 gallons per minute (gpm) are used to deliver cooling in a precise and efficient manner. The heat load is ultimately ejected to the cooling tower, which uses evaporative and drip technology to lower the water temperature before returning it to the chillers. Electrical consumption by HECC resources at the NAS facility hovers at the current building capacity of 6 megawatts (MW). Electrical service arrives at 13.8 kilovolts (kV), and is transformed and delivered to electrical switchgear at 480 volts (V) for the HECC systems and 2.4 kV for the chillers. A series of rotary uninterruptible power supplies (RUPS) serve as a backup. All electrical and mechanical infrastructure components, including chillers, pumps, and the cooling tower, are managed by a building management system for electrical efficiency through switchgear, motor control centers, and variable-speed motors.

1.4 Modular Supercomputing Facility

1.4.1 Limitations of the Primary NAS Facility

In its current configuration, Pleiades stresses the primary NAS facility's engineering thresholds in almost every infrastructure category, as the increased processor and memory density of each system augmentation has resulted in more power, cooling, and floor loading requirements. Starting with the integration of new Haswell-based nodes in 2015, the facility could no longer support the power and cooling requirements of new compute nodes without the removal of older-generation nodes that were still cost effective to run. The early retirement of productive nodes effectively drove up the cost of providing additional compute resources.

The HECC project predicts that NASA's requirements for supercomputing capabilities will continue to grow exponentially over time, as the agency leverages HPC to pursue its challenging missions. To meet these requirements, HECC must continue to provide the funding needed to upgrade and replace the supercomputing resources that NAS hosts for the agency. It is critical, therefore, for NAS to realize the full value of adding new compute resources by overcoming the limitations of its current facility space.

1.4.2 Expansion and Integration Strategy

Once it was determined that additional facility space and resources were required for HECC to expand its supercomputing services, NASA commissioned a trade-off study to evaluate its options: (1) restructure the existing NAS facility; (2) construct a new building; (3) move compute resources offsite to a larger, existing data center; (4) utilize commercial HPC cloud resources; or (5) install a quickly deployable modular data center (MDC). Results indicated that the fastest, most cost-effective approach would be to deploy an MDC. As a lower-risk approach before committing to a large-scale facility, NASA decided to develop a proof-of-concept project, known as the Modular Supercomputing Facility (MSF), with the goals that the system should:

- Represent the most cost-effective way of delivering compute resources that enable science and engineering returns to NASA;
- Be capable of being operated in an energy-efficient and environmentally friendly manner; and
- Interoperate with existing InfiniBand-connected Lustre and NFS filesystems in the primary NAS facility.

Potential vendors were asked to propose strategies for a flexible, energy-efficient approach that would meet the project goals. Once the contractors were selected, construction and deployment tasks were divided between two teams. The infrastructure team—a partnership between Cyber Professional Solutions and AECOM—was responsible for concrete slab construction and installation of site utilities, power, water, and drainage. The computer/MDC

vendor team—a partnership between SGI, the computer vendor; CommScope, the MDC integrator; and Saiver, the MDC manufacturer—was responsible for module and computer installation, as well as post-installation maintenance.

1.4.3 Site Preparation

The NAS team decided to install the prototype MSF on a 4000-square-foot lot across the street from the primary NAS facility—a distance of about 300 feet. The site is located about a mile from the southern end of San Francisco Bay, so initial groundwork included flood mitigation, including raising the level of the site. Utility duct banks and water lines were installed to connect the site to existing utilities, and a 45x50-foot, 16-inch-thick concrete slab foundation was poured, designed to hold two MDCs weighing up to 135,000 lbs. each. Due to the site's earthquake-prone location, the module was welded to thick steel weld pads embedded in the foundation.

Transformer and switchgear were set onto the slab over conduits for power conductors, which were run under and up through the slab. Power is delivered to the MSF site via 15 kV-rated conductors directly fed from a dedicated breaker in the Ames Research Center substation to a 2,800 kilovolt-amp (kVA) transformer at the site. The transformer steps down from 13.8 kV to 415 V, 3-phase power, which is then distributed through the switchgear; each module has its own dedicated breaker. Ten sets of 750-kcmil conductors run from the transformer secondary to the switchgear main breaker, and four sets of 500-kcmil conductors run from the switchgear into the module's electrical panel.

1.4.4 Module Design

The MDC draws outside air into each end of the module via two fan banks of 12 centrifugal fans each. The air is filtered—and conditioned if required—before it travels into two separate cold aisles and through the racks, and then exhausted into a common hot aisle in the middle of the module for release back to the outdoors.

A programmable logic controller (PLC) controls the operating environment, adjusting dampers for recirculation of hot air, solenoid valves to run water through the evaporative cooler, and fan speeds based on temperature and pressure sensors located inside and outside of the module. Power meters measure total power draw for the module and each of the four Starline busways that feed the compute racks.

The MDC is capable of holding twenty 24-inch wide racks, in two rows of ten each. For our installation, we installed only 18 racks—16 compute racks and two I/O racks—with two blanking panels (to control air circulation) at the end of each cold aisle. The module's four busways each feed power to four compute racks. Each compute rack is powered by two 415 volts-AC (VAC), 3-phase feeds through IEC309 32A, 5-pin connectors. The power distribution units (PDUs) within the rack distribute the 415 V, 3-phase input as 240 VAC

single-phase to the 16 power supplies in the rack that output 12 volts-DC (VDC) to the compute and fans. Powering the module at 415 V, 3-phase eliminates the electrical losses associated with the traditional 480–208 V step-down that occur in the the primary facility (Building N258), saving 12 kW.

While the San Francisco Bay Area's weather is mild, there are days when the outside temperature cannot meet the ideal cold aisle settings of 15–27°C (59–81°F). Fortunately, hot days are almost always complemented with low relative humidity, and cooling the supply air can easily be accomplished with an evaporative cooler. When the outside air temperature exceeds 27°C, the air is drawn through an evaporative media—an impregnated glass fiber, honeycomb-like material that has been saturated with water. The heat in the air evaporates the water as it passes through the media, raising the humidity of the air stream and lowering the air temperature. With a maximum cold aisle temperature of 27°C, evaporative cooling will be needed approximately 300 hours per year, requiring an average of about 3.5 gallons per minute of water—for an average yearly water consumption of about 65,000 gallons.

Solenoid valves control the wetting of the evaporative media by pulsing on and off to limit waste. The evaporative cooler has four columns of media, and the PLC controls which columns to wet to provide the proper amount of cooling. The water is run through the evaporative media only once without the use of any water treatment, which allows it to be drained into the center storm drain system. Measurements show that the amount of water lost due to evaporation or drainage in the module is 5% of the amount that would be needed if the compute racks were installed in the conventionally cooled primary NAS facility.

On cold days below 15°C (59°F), the air in the hot aisle can recirculate back to mix with the incoming supply air to increase the air temperature and/or lower the relative humidity (RH) below the 80% maximum setting. In the Bay Area, the recirculating configuration is quite common, as the outside supply is at or above 15°C/80% RH or less for half of the yearly hours.

1.4.5 Power, Cooling, Network

The MDC is controlled by the PLC, which queries sensors throughout the module and makes adjustments to maintain the internal environment within the set operating parameters. Access to the operational control is provided through a user interface (UI) that displays the current module conditions on monitors in three places: inside the module; in the main control room of the primary facility; and in the engineering office. The UI displays detailed measurements for temperature sensors, fan performance, and power/voltage/current draw. The data provided is sampled every 10 seconds and stored in a log file for trending and evaluation. The computer system's power draw is typically about 300 kW, averaging 20–22 kW per rack. (For comparison, LIN-PACK testing was conducted with an average power consumption of 439 kW). At 22 kW per rack, the fans on the backs of the racks are moving 3,000 cu-

bic feet per minute (CFM) of air per rack. Originally, the racks were not sealed for a tight cold-aisle/hot-aisle configuration, and the module's supply fans had to be overdriven to overpressurize the cold aisle and to keep air from the hot aisle from being drawn back into the cold aisle by the rack fans. When the racks were first powered on to run diagnostic tests, there were several instances where nodes powered off due to overheating because the module's fans were set too low. While overpressurizing the cold aisle was effective in cooling the nodes, it was to the detriment of total power consumption. For the initial setup, depending on how conservative the control parameters were, fan power ranged from 15–45 kW.

Subtle changes were made to the module that improved air management and lowered the fan power. Large metal mesh debris filters in the exhaust airflow of the module were removed to reduce pressure in the hot aisle. Open spaces between the I/O racks and the adjacent compute racks were sealed with large blanking panels. The decorative openings in the top sheet metal enclosure above each rack to contain cables were sealed. The gap between the floor and the rack bottom as well as the gap between the rack sides and module's wall were also sealed. Finally, the open area above the top nodes was blanked off, basically extending the top of the rack. After these changes were made, processor temperature testing was conducted to determine the best operating settings.

The target processor temperature is 70°C, which is a typical high temperature on a 22 kW Broadwell rack in the 20°C (68°F) primary computer room floor. For temperature testing, diagnostic software was run to provide a stable power load on each processor. The total power load was 400 kW (25 kW per rack), about 15% higher than a typical workload. SGI rack management software recorded the processor and air intake temperatures, while the module's PLC recorded airflow. The nodes at the top of the rack are most affected by poor air separation, with hot air spilling over the top of the rack. By setting the module's fans to supply 43,000–45,000 CFM (air flow total to two cold aisles), processor temperatures drop below the 70°C target. When module supply airflow drops below 40,000 CFM, the compute rack fans pull air from the hot aisle to meet their 48,000 CFM requirement (16 racks at 3,000 CFM per rack). Increasing airflow continues to reduce processor temperature, but at the cost of additional fan power. To keep fan power at a minimum, the module is operated at 43,000 CFM, which requires 8 kW of power.

1.4.6 Facility Operations and Maintenance

In this section we present more detailed information about recent operating trends. The data is representative of the facility's performance since it went into production in January 2017.

While the cold aisle temperature increased slightly as summer progressed, we did not need to change our operating parameters from previous months, other than an increase in the running of water. Testing of the evaporative

system has shown that passing water over the evaporative media does not require an increase in fan power to improve airflow.

Current operating settings for the cold aisle are a temperature range of 15–27°C (59–81°F) with relative humidity at 20–80%. The lowest airflow setting is 43,000 CFM, which is a setting of 40% fan speed in the PLC, drawing only 350 watts per fan. The airflow will never drop below this setting and will only increase when the hot aisle exceeds 44.5°C (112°F). A 44.5°C hot aisle means that the difference between the cold aisle and hot aisle temperatures, Delta T, is 17.5°C (31°F), at the maximum cold aisle of 27°C.

Electra's Power Effect on Delta T: With the module's fans set to a constant airflow of 43,000 CFM, the hot aisle/cold aisle Delta T is dependent on Electra's power consumption. The Delta T trends at 15–16°C for normal workloads of 350 kW. For the module's control logic, Delta T is not limited until the hot aisle temperature exceeds 44.5°C, at which time the airflow will increase to maintain the hot aisle maximum setting. It should be noted that hot aisle control is just one of five fan strategy programs that can be used to control the module's environment. Each program controls airflow and Delta T in slightly different ways. Because of the significant airflow on the rack fans, hot aisle control has been identified as the best fit for our application, but other strategies may be considered as experience is gained from more operating time with the module.

Damper Settings Dependent on Outside Temperature: The module's dampers adjust to maintain a constant cold aisle temperature over a fluctuating outside temperature. When the outside temperature falls, the outside air damper changes from 100% to 20% open while the recirculating air damper acts in a complementary fashion and changes from 95% to 65% closed (35% open). The adjustable dampers allow for a 16°C cold aisle temperature while the outside air varies from 5° to 20°C.

The dampers also adjust to maintain the cold aisle humidity, even if it means raising the cold aisle temperature. In cases where the outside air is within the cold aisle range of 15–27°C, but the outside air relative humidity is over 80%—such as on a rainy day—the recirculating air damper will open to mix hotter air with the incoming air to lower the relative humidity below the set point. In the Bay Area, 27°C dry-bulb temperature days with 80% humidity do not occur, so there is little concern about inability to control the humidity in the module.

Cold Aisle Temperature Compared to Outside Temperature: Figure 1.3 compares the cold aisle temperature ranges on a daily basis with the outside temperature ranges over an eight-week period. For this data set, the cold aisle temperature was set to range between 15–27.2°C (59–81°F). As shown in the chart, the cold aisle ranges generally match the outside ranges; where they do not match, the “Water Used” line shows the effectiveness of the adiabatic system. At the extreme in early September, the outside temperature rose above 40°C on two days. While the adiabatic system was not able to keep the cold aisle temperature in the target range, it did keep it below 30°C.

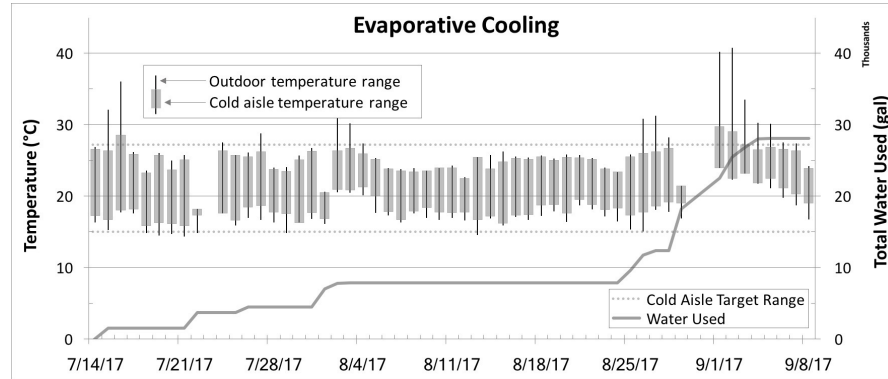

FIGURE 1.3: Evaporative cooling in the MSF over an eight-week period.

This increases our confidence in the MDC’s ability to maintain a cold aisle maximum that is well below the $40+^{\circ}\text{C}$ set point, at which compute nodes will start to shut themselves off due to heat.

1.4.7 Environmental Impact

As mentioned previously, an important selection criterion for the MSF prototype was that it must be environmentally friendly. The existing NAS supercomputer facility is a traditional data center that uses a chilled water loop for heat transfer from the computer floor. With a constant compute power load of 4.0 MW, Building N258 uses approximately 1.0 MW to power the chillers and cooling tower that cool the computer systems. In addition to its power usage, the cooling system consumes an average of 50,000 gallons of water per day.

Fortunately, the weather in the Bay Area is very temperate and for most hours of the day, the outdoor air temperature is sufficiently cool for computer operation. The MSF prototype design procured by the NAS team is able to exploit the local weather to reduce both water usage and the power needed for cooling.

The Electra system uses an unusual combination of outdoor air and fan technology to remove the heat it generates, and consumes less than 10% of the energy used in traditional supercomputing facilities. As a result, the system has achieved a power usage effectiveness (PUE) rating of 1.03—well below the computing industry standard of 1.7 PUE. The PUE is a measurement that reflects the ratio of energy used by the computing equipment to energy used to power the entire data center, including cooling, lighting, and staff workstations.

The system’s power draw varies from a low of 250 kW to a high of 360 kW; the PUE is consistently under 1.03 when Electra is performing a typical work-

load of 300 kW or higher. Because the module's non-compute power consumption is constant at 8 kW, the PUE only rises above 1.03 when the batch processing system is collecting nodes to run a large job or nodes are taken out of service for system testing. When compared to the resources that would be used if Electra were installed in the conventionally cooled primary NAS facility, this translates to a savings of more than a million kilowatt-hours of energy each year—enough to power five Broadwell racks—and a reduction of more than a million gallons in annual water usage.

1.5 Electra Supercomputer

The computational system installed in the MDC is known as Electra. It consists of 1,152 nodes, installed in 16 racks, and has a theoretical peak performance of 1.24 PF. Each node has two 14-core, 2.4-GHz Intel E5-2680v4 (Broadwell) processor chips and 128 GB of memory. There are 4 IRUs in each rack, with 18 compute nodes per IRU. For every two racks, there is a rack leader controlling them. The nodes are interconnected via two independent FDR InfiniBand fabrics in a hypercube topology. I/O traffic is isolated to the ib1 fabric and MPI/system communication is primarily on the ib0 fabric.

The compute system is mostly self-contained within the module, but from a user perspective, it has been tightly integrated with the Pleiades system in Building N258. Electra users log into Pleiades front ends, and their batch jobs have full access to the NFS and Lustre filesystems, which are located in the primary compute facility and shared by all HECC resources. A single Portable Batch System (PBS) server manages all of the jobs for Pleiades as well as Electra; user jobs are routed to the appropriate system by specifying the hardware model types associated with each system.

1.5.1 Performance

On its very first attempt in October 2016—6 weeks after the start of module assembly—Electra achieved an Rmax of 1.096 PF on the LINPACK benchmark. This was sufficient to place it in the top 100 systems in the November 2016 edition of the TOP500 list. [14] While facility information is not available for some systems in the TOP500 list, we believe Electra to be the top system in the list that is module-based. On the High Performance Conjugate Gradients (HPCG) benchmark, Electra measured 25.2 TF, sufficient to place the system at number 46 in the world on the November 2016 edition of the HPCG list. [7]

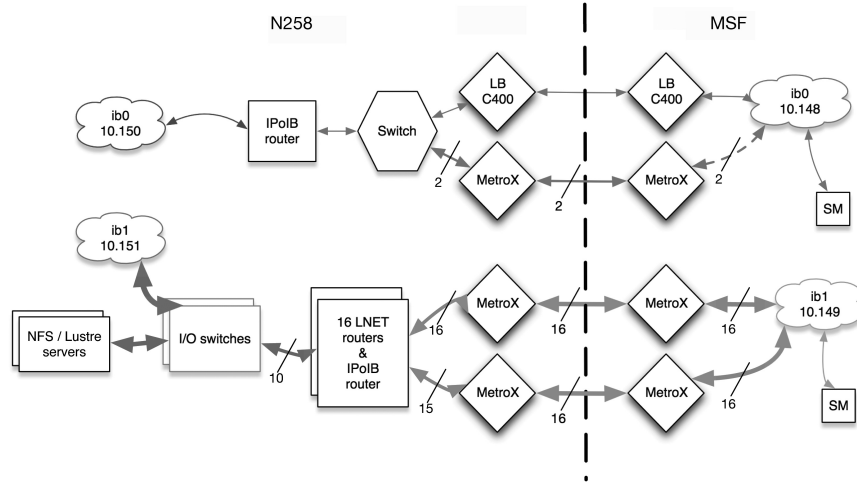

FIGURE 1.4: Components connecting Electra’s compute nodes in the MSF to user filesystems in Building N258, the primary NAS facility.

1.5.2 I/O Subsystem Architecture

The cluster management infrastructure used to provision and manage Pleiades and Electra utilizes the same software and hardware components, so the two supercomputers can be managed as a single instance rather than two independent systems. This reduces the amount of required hardware and labor, and maintains consistency between the systems. Although they are highly integrated, the systems are distinct from the user’s perspective: jobs are not allowed to span the two systems due to bandwidth limitations.

As shown in Figure 1.4, access to the HECC filesystems is facilitated through Lustre and IP routers connected via Mellanox MetroX long-haul InfiniBand switches and Obsidian Longbow InfiniBand range extenders. As discussed in Section 1.3.2, the Lustre routers were proven in a previous network configured between the primary NAS facility and the Merope supercomputer, located in an auxiliary facility. However, with Electra the IP routers were utilized to minimize the InfiniBand connectivity required on the NFS servers. In the Merope deployment, additional InfiniBand host channel adapters were added to multi-home the NFS servers on all of the required IB fabrics.

With the exception of the I/O subsystem, Electra is very similar to the Broadwell subsystem of Pleiades. Given that fact and that about 900 feet of cabling was needed to reach the user filesystems, we focused on the performance of the I/O infrastructure. In particular, we wanted to determine how many Lustre routers were required to achieve similar I/O performance to Pleiades.

We planned to use up to ten Lustre routers in the I/O infrastructure (these

are called “LNET routers” in Figure 1.4). In order to test the sensitivity of I/O performance to the number of routers, we varied the I/O configuration to have two, four, and then ten routers. For each setup, the applications team used a variety of applications from the standard workload on Pleiades to measure I/O performance. Some applications ran stand-alone, filling the system, while others were run with a variety of user jobs sharing the system. We found that application performance suffered significantly when only two or four Lustre routers were available, and consequently the full complement of ten routers was put into production.

1.6 User Environment

1.6.1 System Software

All HECC hosts run Linux. The compute nodes and the Lustre clients run SUSE Linux Enterprise Server (SLES); the Lustre servers run CentOS. All of the InfiniBand software—including the subnet manager, drivers, and libraries—comes from Mellanox OFED.

1.6.2 Resource Allocation and Scheduling

NAS supercomputing resources are shared among hundreds of projects representing NASA's four mission directorates (MDs): Aeronautics Research (ARMD), Human Exploration and Operations (HEOMD), Space Technology (STMD), and Science (SMD). Each MD is allocated a percentage of the total annual node-hours available on the systems (excluding a small fraction reserved for NAS internal use). Allocations are translated into share percentages to help the PBS job scheduler, PBSPro, guarantee that each MD has an appropriate amount of resources at any time. These share percentages are adjusted as needed to ensure high system utilization and best possible job turnaround. The PBSPro software—originally developed at NAS and commercialized through a NASA technology transfer agreement with Altair Engineering—handles job scheduling. Users submit job requests that specify the number and type(s) of node they need, and PBSPro allocates compute resources, taking into account factors such as MD share, job priority within an MD, number of requested nodes, and job wait time.

1.6.3 User Services

The NAS teams listed in this section provide services to assist NASA scientists and engineers through the entire lifecycle of their projects.

24×7 User Support: Ensures that the agency’s scientists and engineers can make the most effective, productive use of HECC systems around the clock. The team provides users with immediate responses to their questions, and then coordinates custom support from the other service teams, as well as continuously monitoring all systems.

Application Performance and Productivity: Provides a wide range of consulting services to help users optimize performance of their codes, improve scalability, and port their applications to HECC resources. In addition to helping individual users, code optimization results in improvements to resource availability, thereby benefitting the entire user community.

Data Analysis and Visualization: Develops and implements advanced software tools and data analysis technologies, including a sophisticated concurrent visualization framework that enables users to explore high-resolution results in real time on the hyperwall.

Production Supercomputing and Archive Storage: Evaluates, acquires, installs, and operates new systems; develops custom software tools; and implements advanced IT security methods; also provides customized training and support to help users efficiently manage large amounts of data.

High-Speed Networking: Works closely with remote users to optimize their data flows and select the most efficient transfer methods. Maintains high-capacity connections and resolves network issues so users can transfer massive volumes of data seamlessly between NAS resources and their remote systems.

1.7 Application Benchmarking and Performance

Despite having the capability to run applications at scale, HECC compute resources are not commonly used for applications running on more than 10,000 cores. Rather, the system’s primary use is as a capacity resource for projects supporting NASA’s future space missions, fundamental aeronautics applications, and Earth and planetary science research. In fact, Pleiades typically runs more than 75,000 jobs each month, and about 50% of the resources are used by jobs requesting 2,400 cores or fewer.

Given this usage pattern, NAS concentrates its benchmarking on modest-sized computations that represent the actual NASA computational workload. In order to be able to compare the capabilities of the different node types comprising HECC systems and also to equitably charge users for their computer usage, NAS embarked on the process of defining a Standard Billing Unit. An SBU reflects the amount of computing power needed to run a representative workload. Each node type can then be tested to determine the amount of resources used to run the workload and establish its SBU charging rate. By using the relative computing power of each node type and its SBU rate, users can run their jobs on the nodes that execute their codes most economically.

Using past accounting data, six application codes that were heavily executed on Pleiades were identified: three codes from SMD and three representing ARMD, HEOMD, and the NASA Engineering and Safety Center (NESC). This suite of codes makes up the application portion of benchmarking requirements in the HECC requests for proposals (RFPs) for supercomputers. In the remainder of this section we describe these applications and give a brief explanation of how they are used to establish charging rates for the different compute resources (see Tables 1.1 and 1.2).

In 2011, a Westmere node was used as a baseline, i.e., the SBU was defined in terms of the application in SBU benchmark suite in such a way that a Westmere node has an SBU rate of 1. In order to choose the number of MPI ranks to use for each application, the benchmarking team first conducted a strong scaling study on the Westmere nodes of Pleiades. They then picked rank counts to reflect typical usage of each application and verified that there was reasonable scaling behavior at that point. Runtime parameters such as iteration counts were then adjusted so that the execution required about 30 minutes on the Westmere nodes.

In 2017, the SBU suite was revamped, using the Broadwell node type as a baseline. The codes were upgraded to use the latest versions, new core counts were chosen and the runtime parameters were adjusted so that the execution required about 30 minutes on the Broadwell nodes.

Following are the six representative codes in the SBU benchmark suite. All of these codes use MPI for interprocess communication.

Enzo v2.5 is an adaptive mesh refinement, grid-based code, developed by a community of academic participants, that is used to simulate cosmological structure formation [3]. Appropriate input files are used to create data in HDF5 format representing initial cosmological conditions in the setup phase. When the benchmark is executed, the cosmos represented by these binary HDF5 files is allowed to evolve. This benchmark case uses 196 MPI ranks.

FUN3D v13.1 is an unstructured computational fluid dynamics (CFD) code from NASA Langley Research Center (LaRC) that is used for aerospace design analysis and optimization [4]. The code uses an adjoint-based error estimation to perform mesh adaptation. The benchmark grid is a wing-body geometry developed as a Common Research Model (CRM) for aerodynamic prediction validation studies of various CFD codes. The CRM consists of unstructured tetrahedral grids with about 285 million unknowns and 1.7 billion tetrahedral elements. This benchmark uses 2016 MPI ranks.

GEOS v5.16, the Goddard Earth Observing System Model, is the atmospheric general circulation model from NASA Goddard Space Flight Center's suite of models to support climate and weather prediction, data analysis, Earth observing system modeling and design, and basic research [5]. The dataset used is the GMAO global data for year 2000 with a resolution of 360 x 2,160 x 72 for atmosphere and 2,880 x 1,440 x 34 for ocean. The physical problem that it solves is known as the Jablonowski & Williamson Baroclinic Test Case. This benchmark uses 1,344 MPI ranks.

TABLE 1.1: Runtimes (in seconds) for the SBU suite of six applications on different HECC processor types.

Application	Westmere	Sandy Bridge	Ivy Bridge	Haswell	Broadwell
Enzo	2,384	2,524	2,018	1,801	1,616
FUN3D	4,675	4,868	4,144	3,541	3,251
GEOS-5	3,266	3,178	2,373	2,282	2,130
OVERFLOW	4,140	2,728	2,676	2,553	2,555
USM3D	3,299	3,024	2,839	2,290	2,299
nu-WRF	1,076	943	785	751	747

OVERFLOW v2.21 is a CFD code from LaRC for solving complex compressible flow problems. It is widely used to design launch and reentry vehicles, rotorcraft, and commercial aircraft [12]. The dataset used is a three-blade, generic rotor system with a fixed NACA0010 airfoil section and rectangular planform, similar to the UH-60 rotor system. The benchmark geometry consists of about 750 million overset grid points and uses 2,016 MPI ranks.

USM3D v20130926 is an unstructured mesh code from LaRC used to calculate flows over complex geometries such as aerospace vehicles [15]. The dataset used in the benchmark solves the same CRM problem as FUN3D but with slightly different grid size. The wing-body geometry consists of about 105 million unknowns and 623 million tetrahedral elements. This benchmark uses 2,016 MPI ranks.

nu-WRF v8-3.71, the NASA-Unified Weather Research and Forecasting Model, is the latest-generation, mesoscale numerical weather prediction system originated from the National Center for Atmospheric Research. The code has been adapted by NASA for observation-driven regional earth system modeling and assimilation system at satellite-resolvable scale [11]. The Modern-Era Retrospective analysis for Research and Applications, Version 2 (MERRA-2) provides data beginning in 1980, which enables assimilation of modern hyperspectral radiance and microwave observations, along with GPS-Radio Occultation datasets. This benchmark uses a domain size of 600 x 400 x 51 and 1,680 MPI ranks.

To establish the SBU charging rates, each application was run on each node type. The runtimes are shown in Table 1.1. This information is used to calculate the relative number of runs that each application can execute in one hour on 64 nodes (prorated both in time and space, as needed) compared to what could be run in an hour on the baseline 64 Broadwell nodes. Those numbers are shown in Table 1.2. For each node type, the SBU charging rate is a weighted average across all applications of the relative number of runs shown in Table 1.2. This calculation gives the SBU charging rate for each node type, as shown on the last row of the table. Note that the charging factor progressively increases with newer generations of the Intel Xeon architecture.

TABLE 1.2: Relative number of runs for the SBU applications on different HECC processor types.

		Runs relative to Broadwell				
Application	Weight	Westmere	Sandy Bridge	Ivy Bridge	Haswell	Broadwell
Enzo	20%	0.29	0.37	0.57	0.77	1.00
FUN3D	20%	0.30	0.38	0.56	0.79	1.00
GEOS-5	15%	0.28	0.38	0.64	0.80	1.00
OVERFLOW	20%	0.26	0.54	0.68	0.86	1.00
USM3D	10%	0.30	0.43	0.58	0.86	1.00
nu-WRF	15%	0.30	0.45	0.68	0.85	1.00
Weighted Average		0.29	0.43	0.62	0.82	1.00

1.8 Utilization Statistics of HECC Resources

Since their installation, the HECC systems have experienced extremely heavy utilization. In fact, the utilization has closely tracked system expansions over the years. (See Figures 1.5, 1.6, and 1.7 for Pleiades and Electra compute utilization, and HECC storage utilization, respectively.) The NAS operational approach is designed to best meet the needs of NASA’s users. For example, the configuration of the different batch queues gives users options for trading off maximum runtime versus likely queue wait time—longer job requests tend to wait longer in the queue. Most of the SBUs delivered on the systems are to jobs that run 24 hours or longer. Job queue limits allow runs of up to five days, and many users take advantage of that. When an application requires even more time, NAS allows jobs up to 16 days if there is a compelling reason and support from the project’s MD.

In addition to its continual growth as a capacity resource, Pleiades has also seen an increase in its use as a capability resource. In June 2009, jobs requiring between 257 and 512 cores used more SBUs than jobs in any other category, and the widest jobs were under 8,192 cores. However, a year later, jobs between 512 and 1,024 cores represented the largest category of SBU usage, and the widest jobs were between 16,000 and 32,000 cores. In the twelve months from September 1, 2016, to August 31, 2017, 20.9% of the jobs used from 1,025 to 2,048 cores, and 20.6% used from 2,049 to 4,096 cores. Of all the SBUs run on Pleiades during the year, 67.3% were used by jobs requesting 1,025 cores or more. The widest jobs exceeded 70,000 cores.

Because Electra uses the latest Intel processors, Xeon Broadwell, it has been used more as a capability system for larger jobs rather than a capacity resource. Since its installation in January and through August 2017, 32.6% of the SBUs on Electra were used by jobs requesting 8,193 to 16,384 cores—more

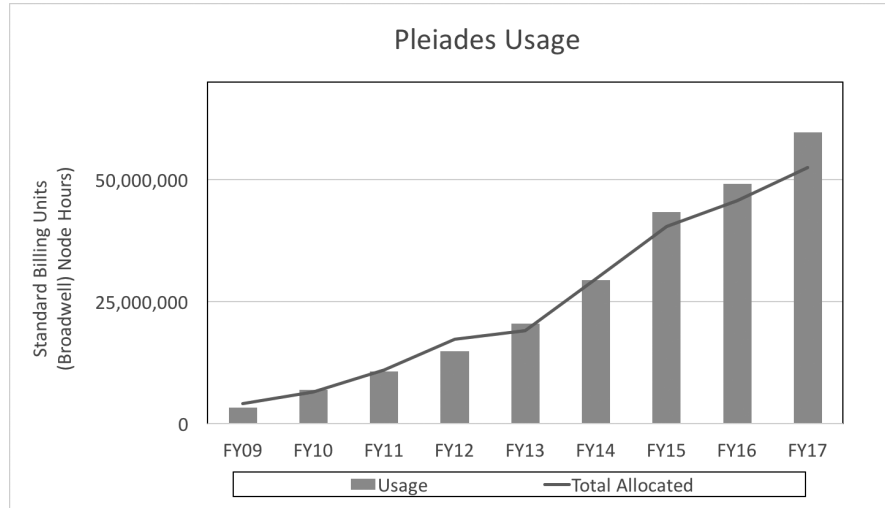

FIGURE 1.5: Compute capacity and utilization growth over the life of Pleiades. The Total Allocated line represents 75% of the maximum theoretically available SBUs.

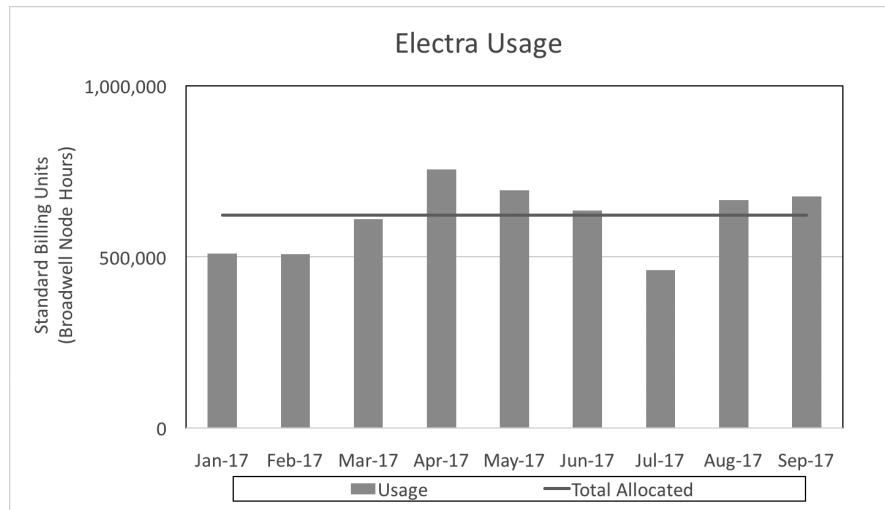

FIGURE 1.6: Compute capacity and utilization growth over the life of Electra. The Total Allocated line represents 75% of the maximum theoretically available SBUs.

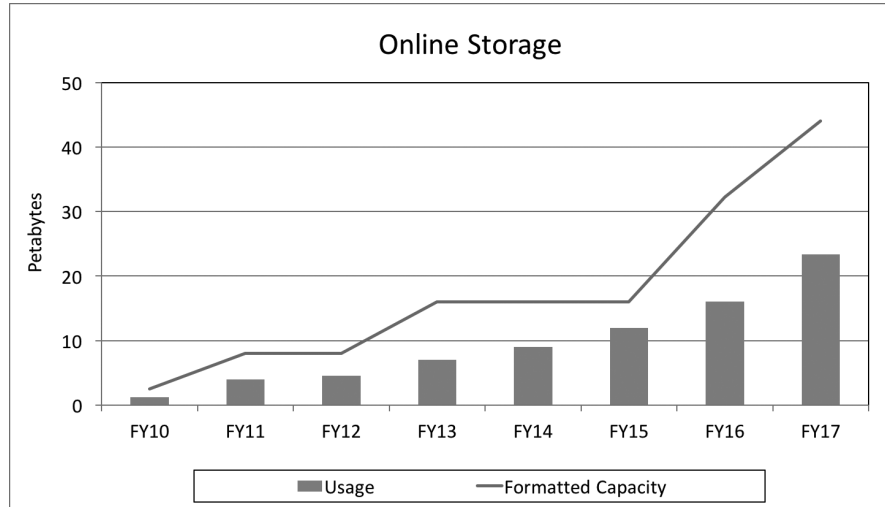

FIGURE 1.7: Storage capacity and utilization growth over the life of the HECC storage system.

than double that of any other category. Of all the SBUs used on Electra, 79.4% were used by jobs requesting 1,025 cores or more, while jobs requesting 8,193 to 32,768 cores accounted for 43.8% of the SBUs.

1.9 System Operations and Maintenance

This section provides an overview of the tools and processes used to administer, debug, monitor, and correct problems on HECC systems. Because all the hosts run Linux, there is a variety of open source tools available to our teams for operations and maintenance activities.

1.9.1 Administration Tools

We use SGI's cluster administration package, Tempo, which is based on open source tools such as systemimager, Oscar, C3, and pdsh and customized for the SGI UV and SGI ICE environments. A key element in the administration of these systems is the Rack Leader Controller (RLC), which communicates with the nodes in the racks it administers over a private 1-Gb Ethernet LAN. The RLC is responsible for all administrative functions within the racks it controls, and is also indirectly responsible for controlling power to the IB switches in each rack.

The RLCs allow the system to scale, as the load on an RLC is nearly independent of the total number of system racks and the racks do not have to compete with each other for LAN bandwidth.

Several “admin nodes” are used for overall administration of HECC resources. The admin nodes communicate with the RLCs rather than the individual compute nodes, providing DHCP, NTP, DNS, and syslog services to the RLCs and to other infrastructure service hosts, such as I/O servers and front-end nodes. All initial install images and updates are built on the admin nodes and then pushed out to the RLCs. Configuration management is handled with CVS and Bcfg2.

1.9.2 Monitoring, Diagnosis, and Repair Tools

Our system administrators use Nagios with several custom plug-ins to monitor infrastructure hosts and filesystems. The Nagios data also provides status information via an at-a-glance display used by 24×7 onsite NAS facility monitors, and via the web for users and program managers.

For the most part, each node runs its own diagnostic and repair tasks. To achieve this, the PBSPro batch scheduling system runs prologue and epilogue scripts at the start and end of every job to perform diagnostic tests on each node used by the job. If a test fails, the node is marked as being offline, and PBSPro selects other nodes for future runs.

All hosts are configured with kdb and crash dumps enabled so administrators can analyze system crashes quickly and develop solutions. It is also fairly common for application codes to exhaust the memory on the nodes; the default Linux behavior is to kill a process in this case, but unfortunately it does not kill the appropriate one. Thus, on HECC systems, Linux is configured to reboot nodes when this occurs so that the error can be handled. A set of scripts using the Simple Event Correlator (SEC) tool monitors system logs and node consoles to detect such out-of-memory (OOM) reboots. SEC then identifies the job and instructs PBSPro to terminate it on the remainder of its nodes.

In addition to these tools, the Application Performance and Productivity team developed a tool called Lumber that is able to collect and scan log messages that result during the running of a job. Despite the fact that such messages can be spread across thousands of files on the system, the tool can locate and gather this information for any job, typically within 30 seconds, automating a process that in the past was laborious to the point of being intractable. Besides facilitating analysis of individual job failures, the tool can be used to find all jobs that experienced a pattern of log messages. Lumber’s efficiency has also led to using log files as a mechanism for storing information about a job, such as executable name, I/O statistics, or power usage. It is then straightforward to produce periodic reports about jobs, such as resources used by specific applications.

1.9.3 System Enhancements and Maintenance

NAS teams have developed several processes to minimize the number of full system outages and maximize availability. For example, compute nodes can be booted using one of several images, which facilitates rolling updates—the default operating system of each compute node can be upgraded at the completion of the job executing on that node.

When scheduling a job, PBSPro checks for the availability of necessary resources, including the Lustre scratch filesystem assigned to the user submitting the job. If the filesystem has been taken down for maintenance, the system can still be fully utilized by other jobs. The NFS filesystems are hard mounted, and user applications can reliably withstand reboots (or crashes) of the NFS servers.

HECC systems support live integration, which enables NAS system administrators to augment the systems with new compute nodes while jobs continue to run on the existing hardware, thus increasing overall availability. When the new nodes are ready to be integrated with the existing system, they are powered down, and the subnet manager sweeping is turned off. Then, the new hardware is cabled to the existing hardware, the cabling is verified, and finally the new hardware is powered up and the subnet sweeping is restarted. The subnet manager sweep integrates the new hardware into the overall fabric and the new nodes are added to the PBSPro's list of available resources.

1.10 Featured Application

To study global systems, Earth scientists run ocean, weather and climate models that require ever-increasing resolution and ever more complex physics representation, driving the need for substantially larger HPC systems than ever before. To help meet these requirements, NAS has been working for over a decade with scientists from the Estimating the Circulation and Climate of the Ocean, Phase II (ECCO2) project, a joint venture led by the Massachusetts Institute of Technology (MIT) and NASA Jet Propulsion Laboratory (JPL) to study ocean currents and their interactions with Earth's atmosphere, sea ice, and marine-terminating glaciers [1]. Their objective is to help monitor and understand the ocean's role in climate variability and changes, as well as to improve the representation of ocean-climate interactions in Earth system models. The ECCO2 project team uses the MIT general circulation model (MITgcm) [9], a numerical model designed to study ocean, atmosphere, and sea ice circulation. MITgcm is combined with observational data from NASA satellites and in-situ ocean probes measuring sea level, temperature, salinity, and momentum, as well as sea ice concentration, motion, and thickness. This model-data combination requires the solution of a huge, nonlinear estimation

problem. The result of this estimation is a realistic description of how ocean circulation, temperature, salinity, sea level, and sea ice interact on a global scale.

In 2011, ECCO2 project scientists approached NAS with a request for assistance. They wanted to increase the resolution of their global model from $\frac{1}{24}^\circ$ to an unprecedented $\frac{1}{48}^\circ$ and also increase the number of depth levels in the simulation. In order to accomplish this, NAS estimated that such a simulation would produce data at a sustained rate of 10 GB/s. However, at that time, MITgcm did all of its I/O through rank 0; achieving the project's goals meant that the I/O would need to be parallelized. An evaluation of MPI-IO indicated that its performance would not meet the goals, so the NAS team undertook a custom design and implementation in which auxiliary I/O processes were added to handle data compositing and I/O. For example, suppose there is a large MITgcm run that needs N MPI ranks for computing. The domain decomposition takes place in the horizontal plane (x, y) but not in z —that is, each rank is responsible for the full range of vertical points. The desired output is a collection of M full-range horizontal slices. The new approach is to use M auxiliary ranks for I/O. Each of the N compute ranks will send data to a subset of the M I/O ranks; the I/O ranks will then shuffle data among themselves so that each has the data for the slice it's responsible for. It then outputs the desired plane.

In 2014, the ECCO2 scientists used a new MITgcm code to run a very high-resolution global ocean simulation that covered 14 months of simulated ocean time and used a total of 22 billion grid points (242 million grid points at each of 90 ocean depths). Output was written at each hour of simulated time, totalling 10,311 time steps, each with 20 variables (five 3D fields and 15 2D fields)—a total of 5 PB of stored data. To visualize the data, the NAS Visualization and Data Analysis group created movies that could be both produced and viewed at full resolution on the hyperwall. While ECCO2 project scientists successfully used this method to view their data, it was mutually agreed that a more powerful visualization tool was needed.

The NAS group then began developing an interactive visualization tool that allows browsing, side-by-side comparisons, and dynamic linked scatterplot brushing—enabling researchers to interact with their data in real time. Disk bandwidth requirements are reduced by converting the model's floating-point data to 16-bit fixed point values, and compressing those values with a lossless video encoder, which together allow synchronized playback at 24 time steps per second across all 128 hyperwall displays (see Figure 1.2). The application allows dynamic assignment of any two encoded tiles to any display, and has multiple interfaces for quickly specifying various orderly arrangements of tiles. All subsequent rendering is done on the fly, with runtime control of colormaps, transfer functions, histogram equalization, and labeling. The two data streams on each screen can be rendered independently and combined in various ways, including blending, differencing, horizontal/vertical wipes, and checkerboarding, and can optionally be displayed as a scatterplot in their joint

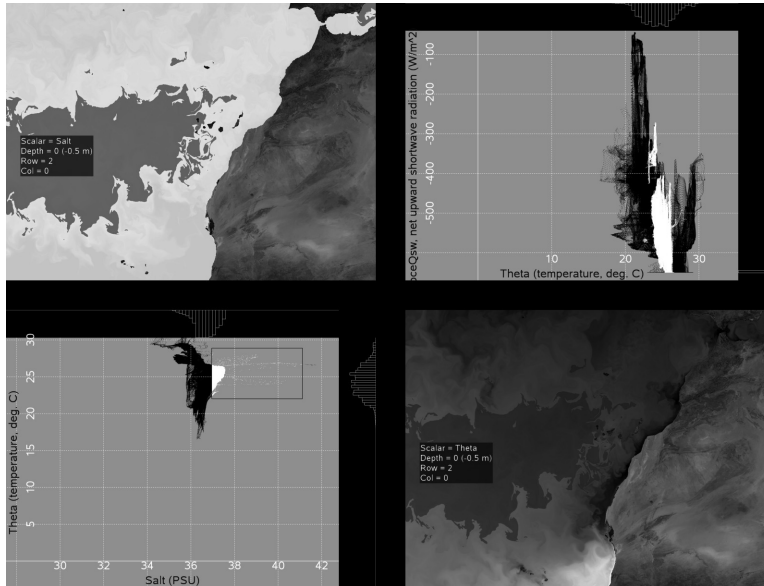

FIGURE 1.8: A portion of the ECCO2 MITgcm visualization on the hyper-wall, showing scatterplots and map-view displays for the same geographical location.

attribute space, as shown in Figure 1.8. All scatterplots and map-view plots from the same (x, y) location and depth are linked so they all show the current brushable selection. ECCO2 project scientists have used the system on several occasions and have found previously unidentified features in the data [2].

During the configuration of Electra, NAS teams used output-intensive runs of MITgcm to size the I/O system. In particular, runs were made with varying numbers of Lustre routers to find out how many were needed. In the end, the NAS Systems team decided on 10 routers; this enabled MITgcm to achieve 40 GB/s of output bandwidth.

During Electra's system testing period, NAS wanted to use short-term runs of MITgcm to fill in the gaps between tests. Unfortunately, initializing each run took about an hour as a single rank read in the startup files; after parallelizing the input routines, the initialization time dropped to a few minutes. This shortened the restart overhead, allowing productive use of the code to fill in the gaps.

1.11 Conclusions

In this chapter, we have focused on the Electra system housed in the Modular Supercomputing Facility (MSF) at NASA Ames Research Center in Silicon Valley, Calif.—an approach that has provided NASA with extended high-performance computing resources while reducing energy costs and minimizing the environmental impact of the facility. Facing a situation where its primary supercomputer facility could not economically support the addition of new equipment, the NAS Division elected to conduct an experiment to study whether HPC equipment was compatible with Modular Data Center (MDC) technology. Specifically, we undertook the design, installation, and deployment of the MSF prototype, which resulted in the Electra supercomputer being housed in a 1,000-square foot module about 100 meters from the primary facility while being integrated into the current HPC environment. Overall, the prototype has been a huge success. The MSF site was transformed from an unimproved lot to a production supercomputer in less than six months. The additional compute resources increased the capacity available for NASA’s large-scale simulations by 16%. In addition, in the nine months since it went into operation, the facility has returned an average PUE of under 1.03. Also during this time period, it has utilized approximately 65,000 gallons of water for cooling the systems—a 95% reduction relative to the same system being housed in a traditional data center facility.

Building on the success of the prototype, NAS plans to use MDC technology for two future expansions. One, which is already underway, has added a second module on the current pad next to the first. Rather than using outside air for directly cooling the compute nodes, NAS aims to gain experience with warm-water cooling in the new module. While the Electra system uses a traditional hot/cold aisle setup, the next iteration is utilizing the HPE water-cooled E-Cell technology, which allows for a higher density configuration. Although the PUE is expected to rise, we expect that the Total-power Usage Effectiveness (TUE) measurement will improve; this is due to the integrated fans in the existing Electra racks being counted as compute load for its PUE calculation and as cooling load in its TUE calculation. In the longer term, NAS plans to significantly expand its available facility space. A Request for Proposals is underway for computer systems and facility space that would support a growth path to 30 MW of equipment over the next five years.

The modular facility approach described here pushes HPC technology to meet NASA’s evolving computing requirements, and makes it possible for the agency to be flexible and add computing resources as needed. NASA will save about half the cost of building another big brick-and-mortar facility, and the MSF can serve as a model for expanding supercomputing facilities in the future.

Acknowledgments

The authors would like to thank Christopher Buchanan, Johnny Chang, Michael Hartman, Henry Jin, Catherine Schulbach, and Dale Talcott for their contributions to this chapter. We are also indebted to our colleagues in the entire NAS Division for their hard work in acquiring, running, and maintaining HECC systems and providing outstanding services to users.

Bibliography

- [1] Estimating the Circulation and Climate of the Ocean Consortium, Phase II (ECCO2). Website. <http://ecco2.jpl.nasa.gov/>.
- [2] D. Ellsworth, C. Henze, and B. Nelson. Interactive Visualization of High-Dimensional Petascale Ocean Data. *2017 IEEE 7th Symposium on Large Data Analysis and Visualization (LDAV)*. Phoenix, AZ, 2017.
- [3] The Enzo Project. Website. <http://enzo-project.org/>.
- [4] FUN3D: Fully Unstructured Navier-Stokes. Website. <http://fun3d.larc.nasa.gov/>.
- [5] The GEOS-5 System. Website. <http://gmao.gsfc.nasa.gov/systems/geos5/>.
- [6] HECC Storage Resources. Website. https://www.nas.nasa.gov/hecc/resources/storage_systems.html.
- [7] High Performance Conjugate Gradients–November 2016. Website. <http://www.hpcg-benchmark.org/custom/index.html?lid=155&slid=289>.
- [8] hyperwall Visualization System. Website. https://www.nas.nasa.gov/hecc/resources/viz_systems.html.
- [9] Massachusetts Institute of Technology General Circulation Model (mit-gcm). Website. <http://mitgcm.org/>.
- [10] Merope Supercomputer. Website. <https://www.nas.nasa.gov/hecc/resources/merope.html>.
- [11] nu-WRF: NASA-Unified Weather Research and Forecasting (nu-WRF). Website. <https://modelingguru.nasa.gov/community/atmospheric/nuwrf>.

- [12] OVERFLOW Computational Fluid Dynamics (CFD) flow solver. Website. <https://overflow.larc.nasa.gov/>.
- [13] Pleiades Supercomputer. Website. <https://www.nas.nasa.gov/hecc/resources/pleiades.html>.
- [14] TOP500 – November 2016. Website. <https://www.top500.org/lists/2016/11/>.
- [15] USM3D NASA Common Research Model (USM3D). Website. <https://commonresearchmodel.larc.nasa.gov/computational-approach/flow-solvers-used/usm3d/>.

Index

- Common Research Model (CRM),
19, 20
- Computational Fluid Dynamics
(CFD), 19
- Dimension Order Routing (DOR), 5
- ECCO2, *see* Estimating the
Circulation and Climate of
the Ocean project, Phase II
- Electra, 3, 4, 13, 15, 16, 21, 28
- Endeavour, 4, 6
- Enzo, 19
- Estimating the Circulation and
Climate of the Ocean,
Phase II (ECCO2) project,
25–28
- FUN3D, 19
- Goddard Earth Observing System
model (GEOS-5), 20
- HCA, *see* InfiniBand host channel
adapter
- HECC, *see* NASA High-End
Computing Capability
Project
- High Performance Conjugate
Gradients (HPCG) list, 16
- hyperwall, 5–8, 18, 26
- IB, *see* InfiniBand
- Individual rack unit (IRU), 5, 15
- InfiniBand, 5
 - Electra, 3
 - Endeavour, 6
 - host channel adapter (HCA), 5,
16
 - hypercube, 5, 6
 - hyperwall, 6
 - Merope, 7
 - storage, 6
- Intel Xeon
 - Broadwell, 3, 5, 12, 20, 23
 - Harpertown, 5
 - Haswell, 5, 9, 20
 - Ivy Bridge, 5, 7, 20
 - Nehalem, 5
 - Sandy Bridge, 5, 20
 - Westmere, 5, 20
- IRU, *see* individual rack unit
- LINPACK, 3, 5, 12, 16
- Linux
 - CentOS, 17
 - out of memory (OOM), 24
 - SUSE Linux Enterprise Server
(SLES), 17
- Live integration, 25
- Lumber, 25
- Lustre, 3, 6, 7, 15–17, 25, 28
- MD, *see* Mission Directorate
- Merope, 5–7
- MIT general circulation model
(MITgcm), 25–28
- Modular Data Center (MDC), 9–12,
14, 15, 28
- Modular Supercomputing Facility
(MSF), 3–5, 9, 10, 14, 16,
28, 29
- NACA0010 airfoil, 20

- Nagios, 24
- NAS, *see* NASA Advanced Supercomputing
- NASA
 - Advanced Supercomputing (NAS) Division, 9
 - Ames Research Center, 2, 28
 - Building 233A, 6
 - Building N258, 6–11
 - Engineering and Safety Center (NESC), 19
 - Goddard Space Flight Center (GSFC), 6
 - High-End Computing Capability (HECC) Project, 2
 - Jet Propulsion Laboratory (JPL), 6
 - Langley Research Center (LaRC), 19
 - Mission Directorate, 17
 - NASA Advanced Supercomputing (NAS) Division, 2
- National Center for Atmospheric Research (NCAR), 20
- Network File System (NFS), 6, 7, 15, 16, 25
- nu-WRF, 20
- OOM, *see* Linux out of memory
- OVERFLOW, 20
- Pleiades, 4–7, 16, 21
- Portable Batch System (PBS, PBSPro), 15, 17, 24, 25
- Rack Leader Controller (RLC), 24
- Rotary uninterruptible power supply (RUPS), 9
- SBU, *see* standard billing unit
- Simple Event Correlator (SEC), 24
- SLES, *see* Linux SUSE Linux Enterprise Server
- Standard billing unit (SBU), 19–21, 23
- Tempo, 24
- TOP500 list, 3, 16
- USM3D, 20