

University of Nebraska - Lincoln

## DigitalCommons@University of Nebraska - Lincoln

---

The Handbook: Prevention and Control of  
Wildlife Damage

Wildlife Damage Management, Internet Center  
for

---

July 1994

### Rodent-Proof Construction and Exclusion Methods

Rex O. Baker

*California State Polytechnic University*

Gerald R. Bodman

*University of Nebraska - Lincoln*

Robert M. Timm

*University of California, Hopland*

Follow this and additional works at: <https://digitalcommons.unl.edu/icwdmhandbook>



Part of the [Environmental Sciences Commons](#)

---

Baker, Rex O.; Bodman, Gerald R.; and Timm, Robert M., "Rodent-Proof Construction and Exclusion Methods" (1994). *The Handbook: Prevention and Control of Wildlife Damage*. 27.

<https://digitalcommons.unl.edu/icwdmhandbook/27>

This Article is brought to you for free and open access by the Wildlife Damage Management, Internet Center for at DigitalCommons@University of Nebraska - Lincoln. It has been accepted for inclusion in The Handbook: Prevention and Control of Wildlife Damage by an authorized administrator of DigitalCommons@University of Nebraska - Lincoln.

**Rex O. Baker**

Professor and Research Project Leader  
Horticulture/Plant & Soil Science  
California State Polytechnic University  
Pomona, California 91768

**Gerald R. Bodman**

Extension Agricultural Engineer —  
Livestock Systems  
Department of Biological  
Systems Engineering  
University of Nebraska  
Lincoln, Nebraska 68583

**Robert M. Timm**

Superintendent and Extension  
Wildlife Specialist  
Hopland Research and  
Extension Center  
University of California  
Hopland, California 95449

# RODENT-PROOF CONSTRUCTION AND EXCLUSION METHODS

## Importance of Rodent-Proof Construction

Rats and mice cause serious damage to all kinds of structures if they are allowed access to them. Damage by rodents has been documented in homes, apartments, hotels, office complexes, retail businesses, manufacturing facilities, food processing and warehouse facilities, public utility operations (especially power and electronic media operations), farm and feed storage buildings, and other structures.

In urban settings, rodents most often cause damage to older, inner-city buildings and utilities in poor repair. New housing developments may experience commensal rodent problems, but problems are more noticeable in neighborhoods 10 to 12 years of age or older. Ornamental plantings, accumulation of refuse, woodpiles, and other such sources of harborage and food are more quickly invaded and occupied by rodents when adjacent to an established rodent habitat.

Many types of land, air, and water transportation systems and their infrastructure also face serious rodent infestation problems. Infestations are of particular concern in the transportation of foodstuffs, feed, and other agricultural products. Commensal rodents consume and contaminate human and

livestock feed. One rat can eat about 1/2 pound (227 g) of feed per week, and will contaminate and waste perhaps 10 times that amount.

Rodents destroy insulation, electrical wiring, plumbing, and other structural components of buildings (Fig. 1). Insu-



Fig. 1. (a) Electrical cord of a freezer in a retail market, severely damaged by house mice; (b) fiberglass batt insulation within walls of a hog finishing house near Lincoln, Nebraska, was destroyed by house mice in less than 3 years.



**PREVENTION AND CONTROL OF WILDLIFE DAMAGE — 1994**

**Cooperative Extension Division  
Institute of Agriculture and Natural Resources  
University of Nebraska - Lincoln**

**United States Department of Agriculture  
Animal and Plant Health Inspection Service  
Animal Damage Control**

**Great Plains Agricultural Council  
Wildlife Committee**

lation damage alone may amount to a loss of several thousand dollars in only a few years. Energy loss from damaged buildings results in added annual costs. Rodent-induced fires from damaged electrical wiring or nest building in electrical panels cause loss of property and threaten human safety.

Rodents also serve as vectors or reservoirs of a variety of diseases, such as salmonellosis, leptospirosis, and murine typhus, that are transmittable to humans. Additionally, they may be sources of swine dysentery, brucellosis, sarcoptic mange, and tuberculosis, all of which affect livestock or pets.

The most effective means of limiting rodent damage is rodent-proof construction. New buildings should be designed and built to prevent rodent entry. Rodent-proofing is a good investment. Designing and constructing a rodent-proof building is less expensive than adding rodent-proofing later. Nevertheless, poor maintenance or management practices, such as leaving entry doors and unscreened windows open, will make the best-constructed building susceptible to rodent entry. Techniques discussed here apply both to new construction and to the modification of existing structures.

Junctures where utilities (pipes, cables) enter structures require special consideration in preventing rodent entry. Some earthquake design criteria require open spaces in important joints and other support areas, to allow for limited movement of tall structures. These present a real challenge in the design of rodent-proof construction.

## Physical Abilities of Rats and Mice

To prevent rodent entry, their capabilities must be understood. For example, both rats and mice can:

- run along or climb electrical wires, pipes, fences, poles, ropes, cables, vines, shrubs, and trees to gain entry to a building (Fig. 2);
- climb almost any rough vertical surface, such as wood, brick, concrete, weathered sheet metal, and many plastic products;

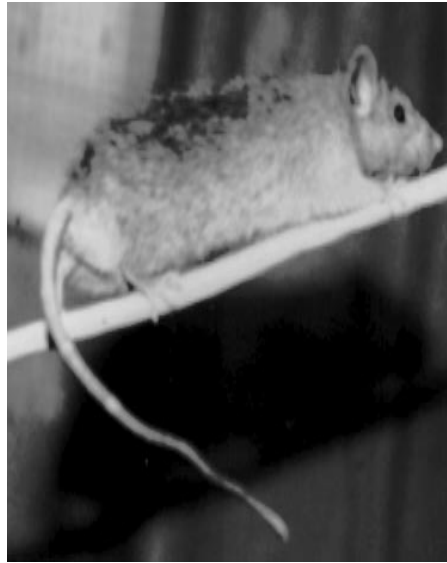

Fig. 2. Rat traveling along an electric wire.

- crawl horizontally along or through pipes, augers, conveyors, conduit, and underground utility and communications lines;
- gnaw through a wide variety of materials, including lead and aluminum sheeting, window screens, wood, rubber, vinyl, fiberglass, plastic, and low-quality concrete or concrete block.

Rats can:

- crawl through or under any opening higher or wider than 1/2 inch (1.3 cm) (Fig 3);
- climb the outside of vertical pipes and conduits up to 3 inches (7.6 cm) in diameter; climb the outside of larger pipes attached to buildings by bracing themselves between the wall and the pipe; climb the inside of vertical pipes, wall voids, or earthquake safety seams and joints between 1 1/2 and 4 inches (3.8 and 10.2 cm) in diameter;
- jump from a flat surface up to 36 inches (91 cm) vertically and as far as 48 inches horizontally;
- drop 50 feet (15 m) without being seriously injured;
- burrow straight down into the ground for at least 36 inches (91 cm);
- reach as high or wide as 13 inches (33 cm);
- swim as far as 1/2 mile (800 m) in open water, dive through water traps in plumbing, and travel in

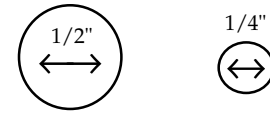

Fig. 3. Rats can gain entry through holes larger than 1/2 inch (1.3 cm); mice can use holes larger than 1/4 inch (0.6 cm).

sewer lines against a substantial water current. In areas where high rat populations exist, it is common for both roof rats and Norway rats to enter buildings through toilets and uncovered drains.

House mice can:

- enter openings larger than 1/4 inch (0.6 cm);
- jump as high as 18 inches (46 cm) from a floor onto an elevated surface;
- travel considerable distances crawling upside-down along screen wire;
- survive and reproduce at a temperature of 24°F (-4°C) if adequate food and nesting material are available.

## Survey for Entry Points

When inspecting sites for potential rodent entry points, look for rub marks, droppings, tracks, gnawing, or other rodent signs. Special attention should be paid to areas discussed under Common Rodent Entry Points (below). Keep in mind the physical abilities and behavior of the particular rodents, especially their tendency to seek shelter behind, under, or in appliances, sinks cabinets, drawers, stored goods, wall voids, false ceilings, and other undisturbed areas.

To conduct a thorough survey, inspectors will need an inspection form and paper for noting and illustrating items needing attention; a good flashlight; a mirror (to see under and behind objects); and screwdrivers and other small hand tools to remove interior and exterior vent grills, appliance base plates, and service doors to attics, crawl spaces, and utility cabinets. A tape measure is usually necessary when preparing a plan and estimating materials needed for repair. A small dustpan, broom, and some lime, flour, or similar powdered material are useful in preparing an area for a follow-up

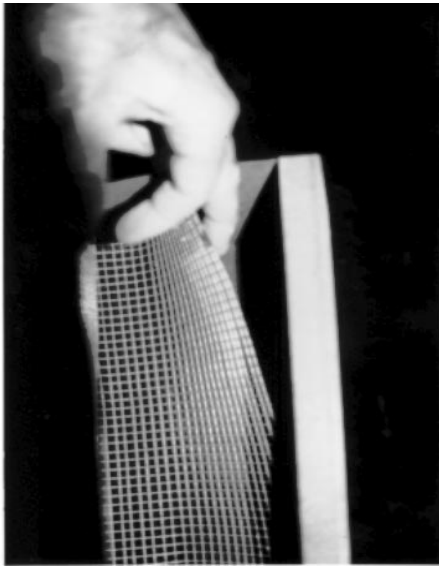

Fig. 4a. Low-profile wall vent with poorly attached hardware cloth, allowing for easy rodent entry.



Fig. 4b. Gap (3/4 x 26 inch) between wall covering and framing at roof joint, allowing rats and mice easy access.



Fig. 4c. Large hole gnawed by Norway rats in weather strip on the base of a warehouse door.

observation of fresh tracks. A camera can be of great value, especially when trying to design a project after leaving the site, or when seeking assistance from someone unfamiliar with the site. A simple item to use when measuring gaps under doors or around pipes, screens, or vents is a common wooden pencil or ball-point pen (usually 3/16 to 3/8 inch [0.5 to 1.0 cm] in diameter) — large enough for mouse entry.

## Common Rodent Entry Points

Many structures have inherently similar rodent entry areas due to similarity in design (particularly entry and service areas), utility sources, and building equipment. For the sake of simplicity, we have attempted to group similar structures and settings.

**Commercial Office Buildings, Hotels, Hospitals, and Retail Stores.** Commercial buildings are constructed from types of materials and design methods that vary greatly in the degree of susceptibility to rodent infestation (for example, metal and concrete versus wood). Most structures eventually become less rodent-proof due to deterioration, alteration, or repair. Heating, air conditioning, plumbing, electrical service, and fire sprinklers provide some of the most

commonly encountered rodent entry points. Neoprene seals, spray-in-place foam, and similar products commonly used to close openings are not rodent-proof.

Even in new buildings, utility pipes, electrical conduit (often at meters or circuit breaker panels), water and gas lines, and communication cables generally have large openings that permit entry of mice and rats. Once rodents have entered walls, they generally have ready access to much of a building via holes for utility pipes and wires in the framing, and via overhead suspended ceilings or other types of construction adjacent to utility enclosures. Specific problem areas include poorly sealed heating and air conditioning ducts; roof and wall vents installed without strong, well-attached hardware cloth screening (Fig. 4a); roof and wall joints and edges without properly installed metal flashing (Fig. 4b); and doors hung unevenly or too high, or lined with unprotected soft rubber weather stripping (Fig. 4c). Refuse and food handling areas are likely to have the greatest rodent pressure. In older buildings, cracks in concrete slabs, brick and concrete block walls, or worn or damaged drain covers allow rodent entry. Air and elevator shafts and laundry chutes also merit close inspection.

**Food Handling Facilities and Warehouses.** Businesses in which food is stored or handled are especially prone to rodent invasion. Good sanitation practices are essential. Keeping food well-sealed is very important and more difficult than might initially appear. Scraps of food can often be found in floor drains, under food preparation equipment and stored products, and around refuse and entry areas. Outside doors are often left ajar or fit poorly due to heavy use, physical damage, or improper installation.

Space under equipment (mixers, stoves, counters, or refrigerators) should allow easy cleaning and inspection, or be closed off completely with rodent-proof materials (Fig. 5). Mice and rats are sometimes found using freezer and refrigerator compressor areas for harborage and water (from condensation on cold coils). Mice are often found in the insulated walls of large coolers. Look closely at corners and edges of metal, or other material covering the insulation, for rodent openings. Drains should have adequate screens or grates to prevent rodent entry.

Food disposal, refuse, and damaged goods areas are often located close to food handling or storage areas and are not sealed from rodents. Areas near loading docks should be closely



Fig. 5. Area under food preparation equipment is raised above a smooth stainless steel floor, allowing for easy cleaning of food spills and open to prevent harborage.

inspected for cracks, broken screens, damaged doors, and uneven floors near doorways. Interior loading docks served by rail cars are difficult to close due to the tracks, but rubber door guards made to fit the tracks are available and will deter rodent entry.

Rodent-infested goods in food warehouses commonly include cereals, flour, and baking mixes; waxed carton drinks; dry pet foods; dried fruits and nuts; fresh produce; paper goods; charcoal briquets, and damaged goods. Products in these categories should be kept in open, easily inspected areas, not in dark corners. Regular and routine removal of such nonsalable or nonusable products should be standard practice to enhance cleanliness and safety and to reduce harborage.

**Apartments and Houses.** Utility entry points include underground electrical and communication trunk lines, and exhaust vents for clothes dryers. Power lines have always been a favorite route of travel for commensal rodents, especially roof rats. Check all roof joints for tightness and presence of flashing, if rats and mice have access to the roof via wire, pipes, plants, or rough-textured walls. Also check roof and sewer vents for adequate screening and sealing, including



Fig. 6. Poorly installed light-gauge roof vent, allowing easy access of rodents between roofing and base of vent. Gaps were large enough to allow rats and pigeons to enter.

presence of tight roof jacks (Fig. 6). Chimneys should be checked for properly installed flashing or for missing mortar.

Rats occasionally enter buildings through toilet traps in inner-city areas with rat-infested sewer systems. In such cases, tracks and water may be found on the rim of toilet bowls. Both roof and Norway rats have been known to enter structures via the sewerage system. This route usually occurs in older (20 years or more) established areas with poorly maintained sewer systems. Mice often enter under entry doors, through holes beside water pipes and electrical conduit, and through the cold air return ducts on forced air furnaces, especially those located in outside cabinets or garages, and underneath mobile homes. Mice and rats often find easy access to garage areas through open doors or under and beside poor-fitting garage doors. Once in the garage, they may gain entry into the main structure along electrical lines, pipes, poorly sealed fire wall sheathing, or around furnace ducts, hot water heaters, or laundry drains.

If rodents are able to reach the attic, they may travel from room to room or unit to unit through openings for pipes, ducts, and wiring. Attics pro-

vide excellent harborage in winter, spring, and fall, but are often too hot during summer. Common attics, basements, or raised foundations in condominiums and apartments are a frequent source of rodent infestation.

Another source of entry to residences, and a source of harborage for rats and mice, are fireplaces—especially the newer preconstructed zero clearance sheet metal units that eliminate the need for concrete mortar and brick. A hollow space is left in the siding and the fireplace support framing between the outside wall and the fireplace. Rats and mice can enter this area from the outside via the roof joint, between the siding and decorative wood corner trim, around gas pipes, or outside wood storage doors.

Once a rodent gets into the attic, inside entry to the fireplace void is often easy because of poorly fitted sheeting or metal collars. Entry to the inside of the fireplace is made from the damper area or cool air and warm air returns on units that provide for air circulation around the firebox. When the fireplace is in use, the heat will prevent rodent entry. If the outside cannot be sealed, glass doors that seal the burn area are recommended to prevent rodent entry throughout the year. Cracked and missing mortar, or poorly fitted siding or plaster, may allow entry through brick or rock fireplaces.

Tile or shake shingle roofs allow rodent entry if the roof is not solidly sheathed with plywood or similar material and the tile is not properly fitted and grouted. Vents without tightly fitted double roof jacks also facilitate access to rodents.

Gaps or flaws in foundations and slabs, or where the wall framing meets the foundation or slab floor, may provide large enough openings for rodent entry. Older buildings commonly have cracked foundations, cracked plaster or mortar, warped siding, or broken and torn vent screens. Wood or masonite siding is especially vulnerable to warping and cracking near corners and around the base of the building. Old, unused holes where utilities formerly entered the structure are also

common, especially in raised foundation and basement homes. Window screens are often left off or fit poorly in older, low-cost apartments and homes, allowing rodent entry from exterior utility lines and pipes running along exterior walls. Runways going to window ledges are often observed on stucco and brick walls and in ornamental plantings next to buildings.

**Manufacturing Plants and Farm Buildings.** Overhead or underground pipes, conveyor belts, and augers commonly found in farm buildings and factories are often used as entry points and routes into and between buildings. Such equipment, particularly if abandoned, may provide harborage as well as food. Rodent-proofing these areas is not easy if the equipment is still in use.

Utility entry points must be constantly monitored for excess openings caused by equipment repair, installation, or modification. Outside walls and doors must also be monitored for damage from equipment or livestock and for damage or wear from heavy use. If work patterns require doors to be open during hours of darkness, when rodent entry is most likely, rodent barriers may be needed, such as a solid fence or wall or a metal wing wall between the foundation and adjacent loading dock areas (Fig. 7).

Buildings constructed with ribbed or corrugated metal siding allow rodent

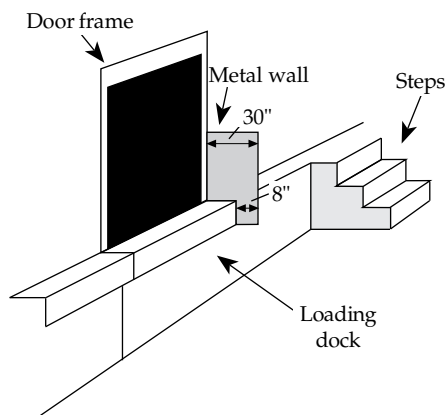

Fig. 7. Rodent barrier or guard used between steps, foundation, or other sources of rodent entry and the loading dock doors when doors must be left open at night.



Fig. 8. Large gap between roll-up warehouse door frame and wall, allowing for easy rodent access.

entry if the bottoms of the siding panels do not rest flat on a solid surface or they are not otherwise closed off. Sections of prefabricated buildings should be assembled tightly, and gaps at joints should be covered with metal flashing. Often, however, they are left open, especially at corners and at the foundation/slab interface.

Roll-up or overhead doors often provide easy entry for rodents, birds, and bats. With the door closed, check for gaps along the sides, bottom, and top of the door (Fig. 8). A gap at the top is common. Rats and mice can easily climb up the space between the door and the inner wall or track to the top, where they gain entry and climb down the inside of the track. Gaps between the track and the wall are also common, especially if the track has been installed on brick walls. Door bottoms may be bent or damaged, leaving gaps along the floor. Uneven floors due to frost heaves may leave gaps when the door is closed.

Screens on windows, crawl spaces, and vents are often damaged in farm and industrial buildings. Check these carefully for needed repair or replacement.

One of the greatest challenges in farm buildings is preventing feed and seed from being a food source for rodents. Good sanitation practices are very

important. Clean up spilled feed, and store feed and seed in rodent-proof buildings and containers. Keep sacked materials off the floor when possible. This facilitates for inspection and reduces harborage.

Excluding rodents from livestock and poultry operations is another challenge due to livestock and manure management and various animal husbandry practices. Nevertheless, rodent-proofing is important and can be accomplished. Many of the entry points already identified for other types of structures apply to farm buildings. Additional problem areas include insulated walls used for harborage, feed bins, and portable feed bunks. These are but a few of the challenges discussed in more depth under Exclusion Methods (below).

## Exclusion Methods: Existing Structures and Equipment

**Holes and Openings.** By gnawing, rats can gain entry through any opening greater than 1/2 inch (1.3 cm) across, and mice through any opening larger than 1/4 inch (0.6 cm). The paired front (incisor) teeth of rats and mice curve slightly inward. This inward curve makes it difficult for them to gnaw into a flat, hard surface. When given a rough surface or an edge to bite into, however, they can quickly gnaw into most materials. To prevent rodent entry, seal all such holes with durable materials. Steel wool, copper gauze (Stuf-it® brand) or screen wire packed tightly into openings is a good temporary plug. For long-term or permanent repair, mix a quick-drying patching plaster or anchoring such as Fixall® into a wad of Stuf-it® before pushing the material into the hole, and smooth over the outside (Fig. 9). If steel wool is used, rust stains are likely to result. Holes 3 inches (8 cm) or more in diameter should be covered or backed with 1/4-inch (0.6-cm) woven/welded hardware cloth prior to filling with a good patching compound (see recommendations under Foundations and



Fig. 9. Patching small holes with copper gauze and a fast-drying patching compound (left), and 1/4-inch hardware cloth for larger holes (right).

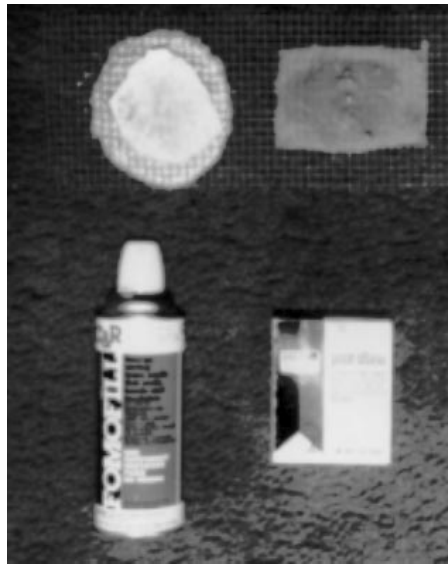

Fig. 10. Frequently used patching materials on 1/4-inch woven hardware cloth backing. Fomofill®, Pour Stone®, Fix-all®, and Custom Plug® are shown as examples of the many materials available.

Floors). Another backing material available is Strong Patch™ (D. P. Wagner Mfg. Inc.), a 6 x 6-inch (15 x 15-cm) sheet metal patch to cover holes up to 5 x 5 inches (11 x 11 cm). It has a self-adhesive backing and a mesh on the surface for better adhesion of the patching compound or other texture.

To close larger openings or protect other areas subject to gnawing, use materials such as those listed in Table 1. Hardware cloth, if not woven, breaks easily. The woven/welded hardware cloth maintains its shape when cut to fit around pipes or other objects. Hardware cloth used to cover gaps and holes can be filled with foam caulk, Fix-all®, Quick-Fix®, or other fast-drying interior patching compounds. When used on the exterior, concrete mortar, plaster, or Concrete Patch® can be used to provide longer-term rodent-proofing (Fig. 10). These are just a few of the many products available.

Close openings around augers, pipes, and electric cables where they enter structures with Portland cement mortar, Concrete Patch®, masonry, or metal collars (Fig. 11). Even a small unprotected opening can be an invitation to rodents.

### Table 1. Recommended materials for rodent-proofing.

<b>Concrete:</b> Minimum thickness of 2 inches (5.1 cm) if reinforced, or 3 3/4 inches (9.5 cm) if not reinforced.
<b>Galvanized sheet metal:</b> 24 gauge or heavier for wall or pipe barriers; 22 gauge or heavier for kick plates or door edging. Perforated or expanded sheet metal grills should be 14 gauge.
<b>Brick:</b> 3 3/4 inches (9.5 cm) thick with joints filled with mortar.
<b>Hardware cloth (wire mesh):</b> Woven, 19-gauge, 1/2- x 1/2-inch (1.3- x 1.3-cm) mesh to exclude rats; 24-gauge, 1/4- x 1/4-inch (0.6- x 0.6-cm) mesh to exclude mice.
<b>Aluminum:</b> 22 gauge for frames and flashing; 18 gauge for kick plates and guards.

The ribs and corrugations in metal siding can be blocked with metal or mortar. Rubber or vinyl weather stops are quickly gnawed through. Design or modify buildings with metal siding by butting siding panels or sheets against solid materials (metal flashing or con-

crete) so the openings are not present (Fig. 12). **Caution:** letting metal siding rest directly against concrete can lead to accelerated rusting and corrosion. The siding should be installed so that openings are no greater than 1/8 inch (0.3 cm) wide. If the siding is installed with the ribs horizontal, the ends must still be sealed or the bottom of the decorative corner trim flashed and closed.

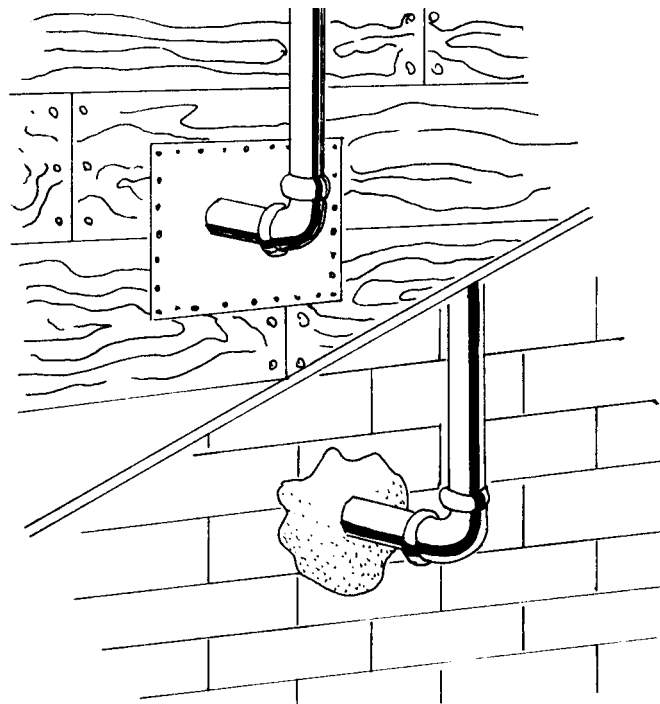

Fig. 11. Seal gaps or holes with rodent-proof materials where pipes, wires, or other similar objects enter buildings.



Metal thresholds can be fastened to floors. Steel pipes embedded in a concrete floor make good rodent-proof thresholds and allow doors to swing free when open. Pipe thresholds are especially useful where doorways are used by wheeled pallet jacks, heavy equipment, or livestock. Install flashing or a metal channel on the lower edge of doors, particularly softwood doors (Fig. 13); a plastic door boot has been successfully used where the door receives low use and the edges are not easily accessible to rodent gnawing. Properly applied flashing extends to within 1/8 inch (0.3 cm) of the edge of the door at the sides and bottom. Close the gap at the top or sides of roll-up doors with conveyor belt material shaped to fit into the side channel frames and mounted on the top door jamb. Bent bottom rails on doors should be straightened. Concrete damage due to inadequate reinforcement or poor placement practices should be repaired or the concrete replaced. A metal or pipe threshold is sometimes preferable or required.

Mechanical door-closing devices save time and help overcome human negligence. Equip doorways used for ventilation with rodent-proof screen doors, or if the door surface is too slick for rodents to climb, modify the existing door so the upper half can be left open for ventilation. Always use a heavy kick plate and solid frame on screen doors in commercial and agricultural

Fig. 12. Metal siding may provide entry points for mice and rats where panel ends are left open (left). Properly installed metal siding rests on the concrete floor or has metal flashing or angle iron to block entry (right).

**Vents and Windows.** Use only metal window screening materials where windows or doors are accessible to rodents. Avoid unnecessary ledges outside windows. When necessary, screen ventilation openings and windows with woven/welded galvanized hardware cloth. Such screening is critical in commercial and farm buildings and where high rodent pressures in residential areas are found. For large openings or where the screen may be subject to abuse, add crossbars to support the hardware cloth. If the opening is an access route, install the screen on a hinged frame.

All vents and duct openings for heating and air conditioning should be screened or raised and/or guarded with an excluder device to prevent rodent entry. Residential cold air return grills can easily be mouse-proofed by placing 1/4-inch (0.6-cm) hardware cloth behind the grill where it is not unsightly. In some applications, power vents can be covered with hinged metal plates (louvered) that open with air flow and close when fans are off. These louvers are only effective if they fit tightly and the sides are recessed to prevent rodents from pushing through them. **Caution:** Hardware cloth less than 1/2 x 1/2 inch (1.3 x 1.3 cm) significantly reduces air flow. In buildings where ventilation

is already marginally adequate or inadequate, such further restrictions may be unacceptable. In some locations, small mesh screens can become clogged with dust or freeze over. In such situations, the use of 1/2 x 1/2-inch (1.3 x 1.3-cm) hardware cloth is a reasonable compromise between ventilation requirements and rodent control.

**Exterior Doors.** Doors should fit tightly, the distance between the bottom of the door and the threshold not exceeding 1/4 inch (0.6 cm). In some instances, it is possible to build up the threshold rather than modify the door.

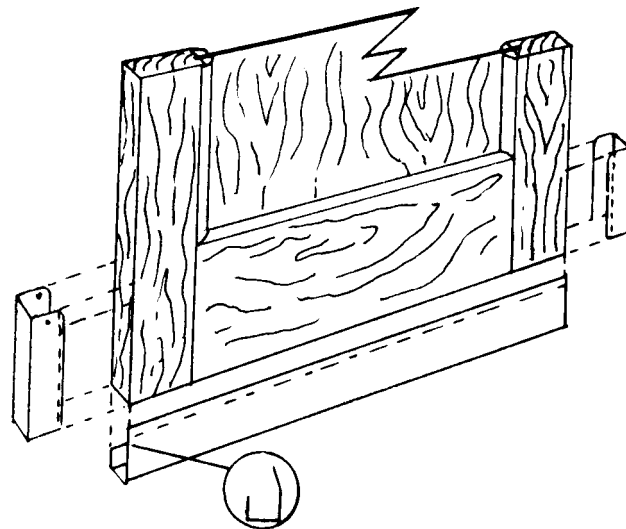

Fig. 13. Metal flashing or metal channel prevents rodent gnawing at bottom edges of a door.



buildings. Light-framed screen doors easily get bent out of shape, allowing rodent entry.

**Foundations and Floors.** Gaps or flaws along building exteriors where the wall framing or siding meets the foundation provide easy entry for rodents. Such openings can be prevented by well-formed and finished concrete work and installation of tight wall framing and siding, or installing metal screed-type flashing between the siding and the foundation. Use of rodent-proof exterior surface materials such as concrete, plaster, or metal sheeting is also effective if properly installed so that all ribs or corrugations are closed.

Rodents can gain entry into buildings with piers or shallow foundation walls by burrowing beneath the floor or foundation. To prevent rat entry by this route, extend foundation walls below ground at least 36 inches (91 cm). This also reduces damage from frost. A horizontal footing extension also may be added to deflect burrowing rodents away from the foundation (Fig. 14). Avoid the use of slab-on-grade construction techniques for agricultural buildings or bulk bin pads. The possible savings in initial construction may be quickly offset by the costs of rodent damage and control measures.

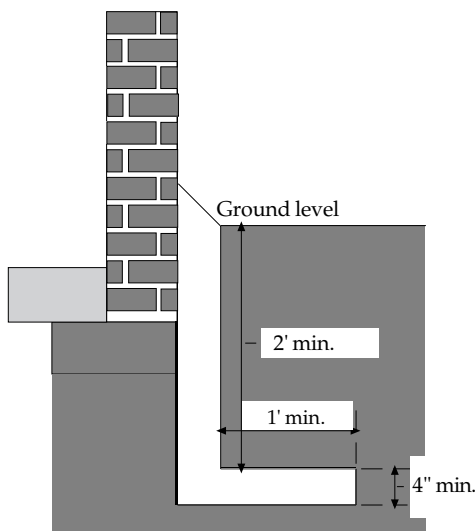

Fig. 14. A 1-foot horizontal footing extension to deflect burrowing rodents.

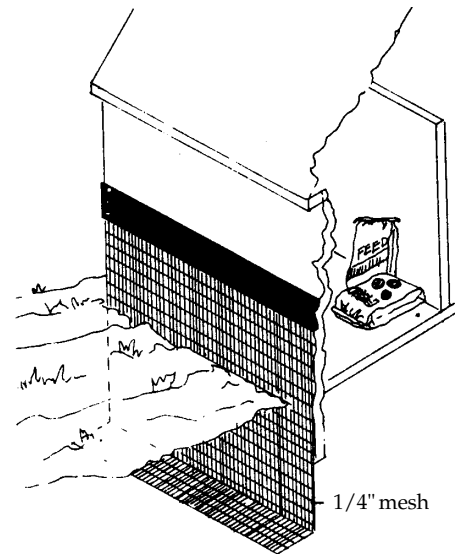
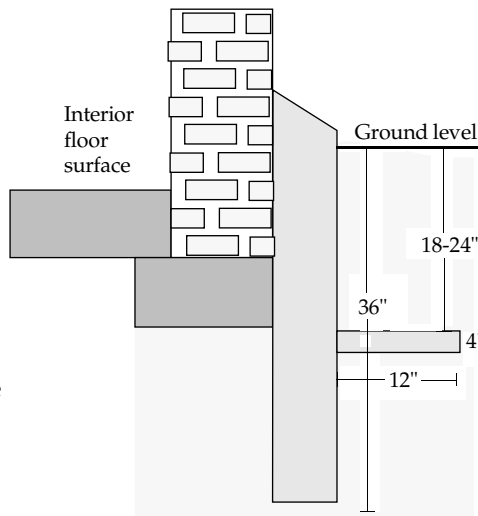

Fig. 15. *Left:* A curtain wall made of concrete will prevent rats from burrowing under foundations to gain entry to buildings. Curtain walls can be installed on existing buildings. A horizontal footing extension often deflects burrowing rodents away from structures. *Right:* Feed sheds, corn cribs, and other existing wooden structures can be rodent-proofed by installing hardware cloth topped by a band of sheet metal. The hardware cloth can also serve as a curtain wall to prevent rodent burrowing.

Rats exert more effort to enter buildings where feed is available. They frequently seek shelter under concrete floors and slabs, where they burrow to find protection. Ideally, install floors, slabs, and sidewalks with deep footings, or with curtain walls of concrete or 1/4-inch (0.6-cm) mesh wire (Fig. 15). The choice between concrete and wire mesh depends on the expected life of the structure. Though wire mesh costs considerably less than concrete, its usefulness generally lasts only 5 to 10 years.

Repair cracks in foundations and floors with concrete or masonry grout. There are numerous quick-setting types of products, such as Fix-all® or Quick-Fix®, which are for interior use, and Concrete Patch®, Rockite®, or Pour Stone® for interior or exterior use (previously illustrated in figure 10). The four last-mentioned products are specifically designed for repairs and have quick setting, good adhesion, and nonshrinking properties which make them ideal for exclusion work. Each, however, is made for a specific application: Pour Stone® and Rockite® are designed to be easily poured into cracks in floors or into holes to anchor bolts or machinery, and set hard in 15 minutes. Concrete Patch® is a mortar-type material for repairing masonry surfaces and has a vinyl polymer to

increase adhesion. It sets in 2 hours and is hard after 12 hours. Quick-Fix® is a durable patching plaster for inside use on plaster, drywall, or wood surfaces. Drying time may be within 30 minutes, depending on thickness. With all of these types of repairs, the use of reinforcement with hardware cloth is usually needed on vertical or overhead horizontal surfaces to add strength and provide the necessary backing. Rodents can claw and gnaw at concrete and Portland cement until it is fully cured, so the use of 1/2-inch (1.3-cm) hardware cloth laid in the top 1/4 inch (0.6 cm) of the repair area may be necessary if rats are currently using the repair area as an entry point. Otherwise, provide an effective temporary rodent-proof protective overlay until the concrete is fully cured. **Caution:** Metal products placed within 1 inch (2.5 cm) of a concrete surface will oxidize and corrode and may discolor the concrete.

If rats have gained access to crawl spaces under building floors, prevent them from getting into walls by using such modifications as illustrated in figure 16.

Maintaining a clean, 3-foot-wide (1-m) weed-free area around building foundations, concrete slabs, and footings often discourages rodents from burrowing as well as eliminates a food

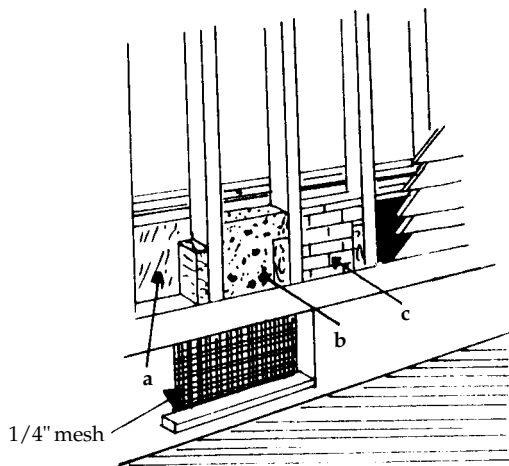

Fig. 16. Method of excluding rats from double walls. In old buildings, galvanized sheet metal (a) may be cut to fit and nailed into place between studs, joists, floor, and sill; in buildings under construction, noncombustible stops of good quality concrete (b) or bricks (c) are recommended.

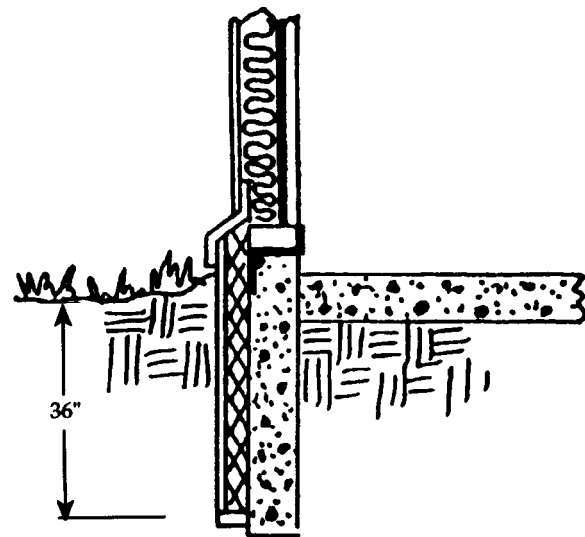

Fig. 17. Perimeter insulation placed on the outside of a foundation, curtain, or stem wall must be protected to prevent rodent damage. Protection is required along the top and to a depth of at least 36 inches below the soil surface.

source and attractive harborage. Where erosion of bare soil is likely, this buffer can be maintained by regular, close mowing of vegetation or by installing heavy gravel. To discourage burrowing, install a strip of 1-inch-diameter (2.5-cm) or larger gravel laid in a band at least 2 feet (60 cm) wide and 1/2 foot (15 cm) deep.

**Interior Rodent-Proofing.** When rats or mice are present in a building, attention must be given to interior as well as exterior rodent-proofing to remove all sources of shelter. A combination of actions is required in such instances, as no single effort is likely to yield the desired result.

Concrete floors are preferred to wooden floors. An attempt should be made to seal off rodents. Use traps to remove the rodents, or place poison bait packets through openings in the floor or wall and then seal the openings with galvanized metal or hardware cloth and patching plaster as previously discussed. Promptly treat new openings as they are found. In occupied buildings, always trap the rodents before sealing interior walls to avoid odors, stains, and an influx of insects that feed on decaying rodent carcasses.

Eliminate rodent hiding places beneath and behind equipment. Feeders in live-

stock facilities should have flat bottoms and be designed and installed so that rodents cannot find shelter beneath or behind them. Give special attention to storage rooms, closets, feed storage, or other areas where construction techniques may allow rodents access to walls, floor spaces, or attics. Stacks of wood and other stored items should be 18 inches (46 cm) above the floor and 18 to 24 inches (46 to 61 cm) away from walls to allow for proper cleaning and inspection. Warehouse stock should always be stacked off the floor on pallets and away from walls, and it should be rotated often to prevent development of infestations in undisturbed areas.

Rodents often gnaw into wall materials at corners or where joints in construction materials provide an edge. Poor construction techniques may allow rodents to gain access through materials that are otherwise considered rodent-proof.

Perimeter insulation is a necessary part of energy-efficient construction. Placing insulation on the exterior of foundation walls subjects it to mechanical damage as well as infestation and destruction by rodents. To prevent damage to perimeter insulation, use sandwich wall construction in which the insulation is placed within the con-

crete. Insulation placed on the outside of a foundation wall requires protective-covering material. Suitable materials include cement board, high density fiberglass-reinforced plastics, troweled-on coatings such as Block Bond®, or Surewall®. In such situations, metal flashing should be used to prevent the potential for entry routes for subterranean termites. Several companies now manufacture special coatings for exterior perimeter insulation. Examples include DuraWall™ and Securewall™.

Extend protective cover materials at least 36 inches (91 cm) below finished grade. If the protective layer ends less than 36 inches (91 cm) below grade, add a horizontal ledge that extends outward at least 1 foot (30 cm). All top edges and corners must also be protected with a close-fitting heavy-gauge metal flashing (Fig. 17).

**Drains and Pipes.** Both rats and mice use drainage pipes or sewage systems as routes to enter buildings. Equip floor drains with metal grates held firmly in place. Grate openings should not exceed 1/4 inch (0.6 cm). Maintain 1/2-inch (1.3-cm) hardware cloth over sewer roof vents in rat-infested areas. If the sewer system is known to be rat-infested, a "Rat Guard" one way flap valve may be

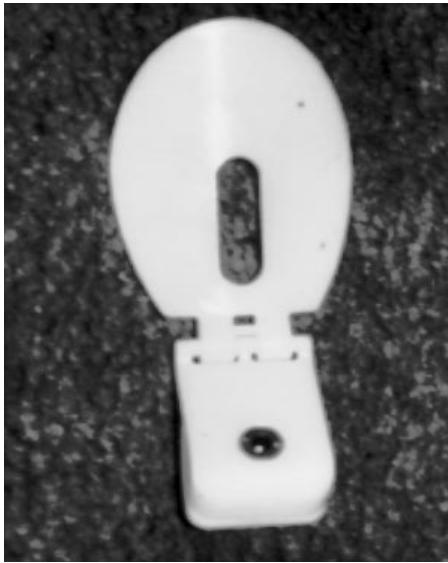

Fig. 18. “Rat Guard” one-way flap valve is available for placement in toilets where the sewer system is known to be rat-infested.

placed in toilets (Fig. 18). Sewer laterals should be checked for openings that could allow rodent entry. Smoke-producing leak detectors are often used by agencies checking sewer lines for leaks or openings. If openings are detected, replace the pipe or wrap the pipe break with 1/4-inch (0.6-cm) hardware cloth and use concrete patching material to seal the area. Rain gutter downspouts are often used by rats to gain access to roofs. It may be possible to screen over openings at the base of downspouts with 1/2-inch (0.6-cm) hardware cloth or a grate, but this will require continued maintenance to remove accumulated debris, particularly where leaves and small sticks are washed from roofs into the gutter system. Flap valves have been used here too—swinging shut except when water is flowing. Openings to floor or driveway drains should have covers. Gutter and other drain covers must be kept clean of debris to prevent water backup.

Manure management systems in livestock facilities may be of a type that periodically drains manure or water from the building to a lagoon or other storage area. In such cases, a “floating” metal cover or check valve-style closure at the open end of the discharge pipe, with a hinge at its upper edge, can be effective. The hinge must operate easily so that the cover will open

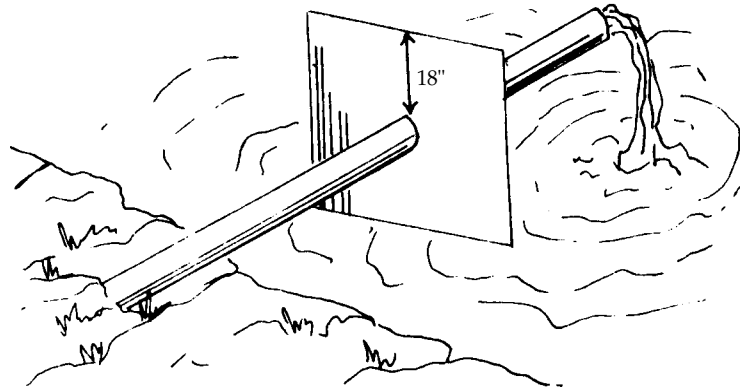

Fig. 19. Shield on manure discharge pipe to prevent access by rodents to open pipe.

when water or manure flows out but will fall back into place when the flow stops in a manner similar to a tide gate used on drains in coastal areas. The potential for such covers to freeze shut, however, can be a drawback. A better method is to extend discharge pipes far enough over the bank or into the lagoon to prevent rodents from jumping or crawling into the open end. Install rodent shields to prevent rodents from gaining access (Fig. 19).

Always cap pump-out ports when under-building manure storages are not in use. Left open, they allow rodents easy entry.

**Physical Barriers/Guards.** To prevent rodents from climbing or traveling along a particular route, install guards made of sheet metal or similar materials (Table 1). Guards must be wide enough and positioned to keep rodents from reaching their outer margins by climbing or jumping. Dock areas may need guards to keep rodents from jumping or climbing from foundations, pipes, steps, or rough exterior wall surfaces, and from infesting trucks or rail cars transporting goods.

A sheet metal band attached to a wall will prevent rodents from climbing. Rodent guards should be at least 14 inches (36 cm) but preferably 18 inches (46 cm) wide (Fig. 20). Inside buildings, such guards can prevent rats and mice from climbing at corners. Used in combination with hardware cloth or other suitable material, they can make



Fig. 20. Sheet metal band attached to outside walls to prevent rodent climbing. Band should be 14 to 18 inches wide and 30 inches above where a rodent can jump from.

a building essentially rodent-proof. These modifications are essential on pumping plants, water treatment facilities, power stations, and communications facilities. They have also been used to make corn cribs, barns, and other older buildings in current use rat- and mouse-proof.

Guards on walls should be at least 36 inches (91 cm) above ground or floor level. Flat guards have been used to prevent rodents from traveling along horizontal or vertical pipes or electric wires (Fig. 21). Cones or discs act as rodent guards on suspended cables, rain gutter downspouts, conduit, ropes, augers, or pipes (Fig. 22). With

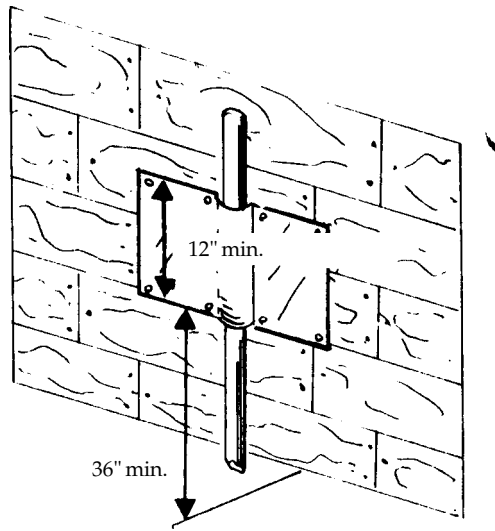

Fig. 21. Guards of various designs can prevent rodents from climbing along wires or pipes.

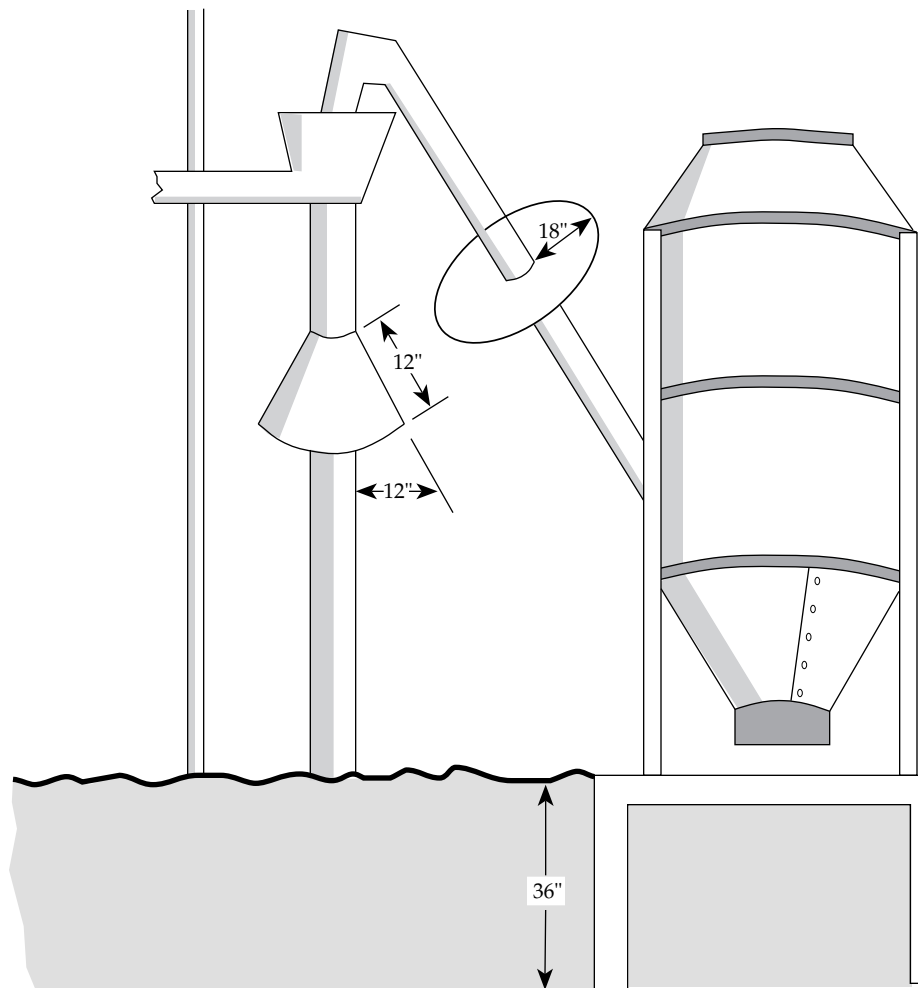

Fig. 22. Guards can be used to prevent rats from climbing augers, pipes, or wires leading to buildings. Footings or foundations for grain bins should extend into the ground to prevent rat burrowing.

some ingenuity, you can design rodent guards to fit any given situation. Free-hanging guards are easily damaged. Circular guards must extend out 18 inches (46 cm) around the line they guard. They are constructed of 24-gauge metal and anchored in place by one or more arms on the side opposite to that accessible to rats. Cone-shaped circular guards prevent rats from climbing vertical pipes, pilings, and trees. Shields or wire guards made of 1/4-inch (0.6-cm) wire mesh are useful in excluding rodents from the interior of conveyor belts, underground power and communications conduit, feed augers, fan housings, and similar openings.

### **Food Handling and Storage**

**Areas.** Even when all of the holes are plugged, rodents seem to find a way into food storage and handling areas. Sometimes rodents come in with supplies, or they run in through open doors or windows. Often, one or more openings remain undetected. These hidden holes are often below sinks, behind equipment, in false or suspended ceilings, and behind or under cupboards. Once in an environment having all the basic needs, rodents quickly establish viable populations. The solution is to eliminate harborage and exclude rodents from food and water sources inside the building.

All equipment such as large refrigerators, freezers, counters, dishwashers, and sanitizers should be raised and easily movable, enabling cleaning underneath and behind them. Insulated walls and closed areas should be tightly closed off to avoid use as harborage. Openings are commonly seen in new stainless-steel work counters in supports under the work surface, or in areas provided for drains. Drains should be easy to clean but should have rodent-proof covers.

Store food products in rodent-proof enclosures or on shelving at least 18 inches (46 cm), but preferably 30 inches (76 cm) or more, above the floor. Tubular supports (legs) for shelving should be a minimum of 4 inches (10 cm) in diameter to prevent rats from shinnying up from the floor.

Keep all damaged goods and returns, as well as refuse, in a separate rodent-proof room. Loading docks should be very tightly rodent-proofed and only open during daylight hours. All outside doors should be self-closing, have heavy kickplates, and be checked periodically for excessive gaps. In warehouses and storage situations, centralize highly susceptible foodstuffs into areas that can be securely rodent-proofed and closely monitored. These areas should also have rodent bait stations and multiple-capture mouse traps permanently installed around the perimeter.

#### **Livestock Feed Bunks and Bins.**

Rats typically burrow and nest under feed bunks that are placed directly on the ground or near ground level. Properly designed concrete bunks that sit tightly on a concrete base eliminate rodent habitat. Though cattle traffic may discourage burrowing under the concrete slab, a foundation may be needed to prevent burrowing around the sides of the slab that do not receive heavy cattle use. Concrete slabs on which feed bins are placed should have foundations extending 36 inches (91 cm) into the soil at the outer edge to prevent rats from burrowing under the slab. Installing heavy gravel and maintaining a clean, weed-free zone around the perimeter of the slab will also discourage rat burrowing and permit easier detection of rat activity.

**Feed and Refuse Storage.** Livestock or pet feed and edible refuse attract rodents and are a common food source. Always store these materials in metal containers with tight-fitting lids. Food is often available to rodents around homes, kennels, and poultry and livestock feed storage areas because feed is kept in plastic or wood storage bins or hoppers. These storage containers are frequently open at the top, or may be gnawed through the sides. Check nonmetal hoppers frequently for holes and, when necessary, repair with sheet metal. Avoid the use of self-feeders for pets. Feed pets only as much as they will consume at one time and only during daylight hours.

Proper storage and disposal of household garbage and dead animals is a very important part of rat control. Bulk dumpsters are often left with the tops open, or the tops are badly bent, allowing rodent entry. Constant vigilance and calls to the refuse company should correct these situations. Seal bulk trash compactors from rodents. Spilled refuse and juices from crushed contents often create rodent problems under and behind compactors and bulk dumpsters. Clean these areas often and install rodent screening in container drains.

## **Rodent-Proof Building Design Considerations**

The degree of a structure's susceptibility to rodent infestation depends on several considerations that the architect, engineer, builder, and end-user should keep foremost in mind prior to and during construction. All structures, but particularly those intended for human occupancy, should be built to be as rodent-proof as possible.

One consideration is the current and historical level of rodent problems in the general area of the construction site. A project that is in an inner-city redevelopment area with a known history of rodent problems warrants more attention to rodent exclusion than a project in a new urban fringe area with little or no history of problems. Rodent control should be considered during the preconstruction and construction phases. Infestations at these times are common and sometimes even include larger animals such as skunks and opossums. Contracts should require that contractors maintain a clean and debris-free site.

If the area is known to have heavy rat and/or mouse problems, use exterior surface materials that have a hard, smooth surface on at least the lower levels that will be subject to contact with the ground, ornamental plantings, fences, and other potential areas of rodent harborage. A viable alternative is to utilize a smooth-surfaced

decorative band 14 to 18 inches (35 to 46 cm) wide around the structure above the rodent access height, in order to prevent rodents from climbing up exterior walls. Tightly rodent-proof sewer, electrical, communication, water, and natural gas services, as well as exterior doors and windows. Loading docks should have exclusion devices, automatic door-closing devices, and good construction materials that preclude rodent climbing and entry. Stairs to the dock area should have a tight-fitting personnel door far enough from the dock that rodents cannot jump from stairs to the dock. Dock bumper pads should be high enough (30 to 36 inches; [76 to 92 cm]) to avoid being used as steps by rodents.

Another consideration is the building's interior design and intended use. Office buildings with tight-fitting interior doors, tightly sealed wall voids and utility access areas, and no food or water sources are less attractive to rodents than food handling facilities, apartments, hospitals, and warehouses. Pallets commonly used in warehouses provide good harborage for rodents and should be rotated regularly. Coolers and other food storage areas should be centrally located and, if possible, in sealed rooms, separate from other warehouse goods. This confines rodent exclusion to a small area and provides for better observation if problems arise. Even the clutter of machinery, parts, and nonfood stored goods may attract rodents as harborage if food and water are nearby.

Containers for refuse disposal, including bulk dumpsters, should have tight lids. They should be kept clean and tightly sealed.

Earthquake safety joints can provide a route from the basement to the top floor of a building. Use 1/4-inch (0.6-cm) woven/welded hardware cloth between floors in these joints to effectively stop rodent travel. Urethane foam caulk or sheet metal screws have been used to hold the hardware cloth in place without interfering with the



Fig. 23. Chimney with metal stack, heavy screen (animal excluder and spark arrestor), and tight roof to wall and Z-bar flashing joints.

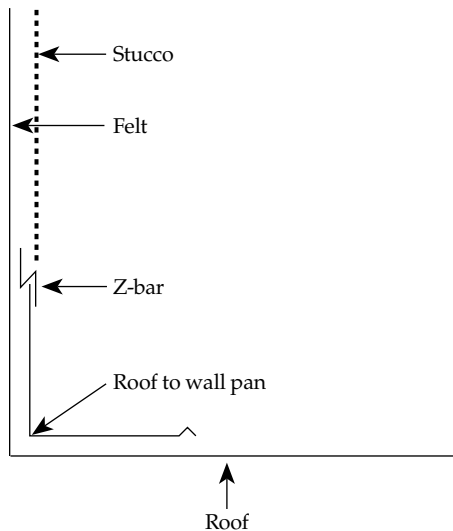

Fig. 24. Z-bar and roof-to-wall pan flashing, when properly installed, prevent rodent entry.

purpose of the safety joints. Install adjustable metal collars around utility pipes or other types of openings. They are available through building supply stores or can be easily cut from 24-gauge (or heavier) galvanized sheet metal. Double walls can best be protected near the foundation or floor area with galvanized sheet metal, hardware cloth, concrete, or other methods, as previously discussed. Use heavy (24-gauge or better) galvanized flashing, called "screed," between the siding and foundation to close any openings created by warped wood or

Masonite, board and batt construction, stucco, or corrugated metal siding. Installation of fireplaces, especially zero clearance sheet metal types, poses a challenge when sealing the wall void created around and above the firebox to the roof. This area must be solidly sheathed with sheet rock or dry wall, and a metal collar called a draft stop must be used at the ceiling and roof lines. When tightly fitted, it serves to prevent rodent movement. It is also imperative that good, tight Z-bar and roof-to-wall pan flashing is properly installed around the outside of the chimney. A metal cap and secure heavy mesh screen should be installed to prevent bird or small mammal entry (Fig. 23). There are many types of metal flashing. The Z-bar flashing is installed so that it is under the felt paper and then bends outward to overlap the roof-to-wall flashing that rests against the roof and wall in an L shape (Fig. 24).

Roofs and eaves often have openings large enough for raccoons and pigeons, as well as for small rodents to enter. Many of these problems in single-family residences and apartments seem to occur where roof lines change angles or elevations, leaving an area under the eaves that is hard to fit with siding. Problems are especially common where the proper roof-to-wall and Z-bar flashing are not tightly cut and installed during initial construction. Shingle or tile roofs are sometimes a problem when they butt up against a wall or around roof vents and at roof edges. Tile and shingles are less of a problem if solid sheathing underlies the roofing material and adjacent walls have properly installed metal flashing. Tile on roofs must be well placed to avoid gaps and the ends should all be sealed with preshaped metal (commonly called "bird stop," Fig. 25) or tile fillers. All other gaps should be filled with concrete grout.

Vents must have openings of 1/4 x 1/4 inch (0.6 x 0.6 cm) or less to prevent house mouse entry (Fig. 26). There are many different types of vents for specialized placement. They include gable vents, exhaust vents, roof vents, foundation vents, and many others. The



Fig. 25. "Bird stop" shaped metal for tile roofs to prevent rodent and bird entry.



Fig. 26. A side wall exhaust vent with 1/4-inch hardware cloth.

building industry has had a problem getting good-quality vents with strong 1/4 inch galvanized hardware cloth properly fastened in place. Many manufacturers are using nongalvanized hardware cloth or light screen wire, and others are simply shaping the wire into place with no fastening method used or using light spot-welding spaced too far apart, allowing the screen to be pushed away from the housing of the vent.

Openings larger than 1/4 inch x 1/4 inch (0.6 x 0.6 cm) can be used if air flow is inhibited, but the vent should be located to prevent exposure to

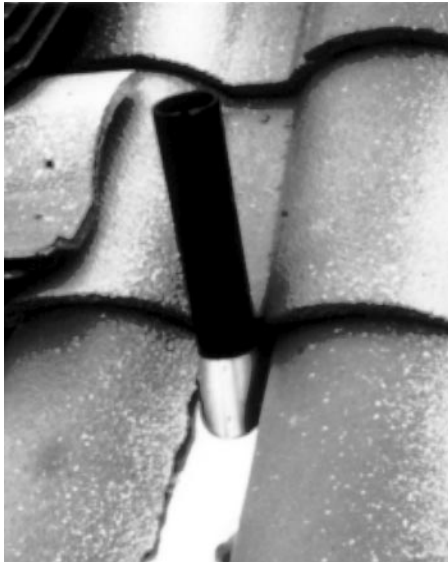

Fig. 27. Soft (upper) roof jack under tile.

rodents. This can easily be accomplished on roofs with smooth sheet metal raised 40 inches (1 m) or higher, constructed in a manner to avoid rough edge ribs or other surfaces that rodents can climb. Place vents on the sides of buildings at least 40 inches (1 m) above the ground level, fences, or shrubs. Use a smooth surface around the vent if the wall material has a rough texture.

Poorly installed roof jacks are a common entry point for rodents. Tile and shake shingle roofs require the use of double jacks, one rigid and the other often soft or flexible. The solid jack is installed over one layer of roofing felt and the sheathing or other substrate, and an overlapping piece of felt is then layered over the jack. The second jack is placed between the layers of roofing (tile or shingles, Fig. 27). When rigid metal is used for the upper (second) jack, gaps left between the tile and the metal should be grouted to prevent rodent or bird entry or nesting.

#### ***Permanent Bait/Census Stations.***

Another method that can be used to prevent the build-up of rodent populations is the installation of permanent rodent "service access areas" around the exterior of buildings. These cupboard-type areas can be built at ground level into walls or foundations near loading docks, trash areas, near utility service panels, corners, or rear alleys. The stations should be large enough to contain an automatic multiple-capture mouse trap (Ketch-All™ or Tin Cat™) and a bait station containing toxic baits. Placebo baits can be used to monitor rodent

population pressure. The panel door should have tamper-resistant screws, bolts, or locks and have two 2 1/2- x 2 1/2-inch (6.4- x 6.4-cm) openings at ground level to allow entry by rats and mice.

For additional information on the control of commensal rodents, see the chapters **House Mice**, **Norway Rats**, and **Roof Rats**.

## **Acknowledgments**

Figures 1a, 2, 4a, b, and c, 5, 6, 8, 9, 10, 12, 18, 20, 23, 25, 26, and 27 by Rex O. Baker.

Figure 1b by Robert M. Timm.

Figures 3, 7, 14, 15, 17, 19, 22, and 24 by Frances I. Gould, David Thornhill and Clint Chapman.

Figures 11, 13, 16, and 21 adapted by Frances I. Gould and David Thornhill from Pratt, H.D., B. F. Bjornson, and K. S. Littig. 1977. Control of domestic rats and mice. Publ. Health Serv. US Dep. Health, Educ. Welfare, Pub. No. (CDC) 77-841. 47 pp.

## **Editors**

Scott E. Hygnstrom  
Robert M. Timm  
Gary E. Larson