

Design of Electro Cardiograph Machine Based on ATmega Microcontroller

Bambang Guruh Irianto¹, Budhiaji², Syaifudin³

^{1,3}Department of Electromedical Engineering, Polytechnic of Health Ministry of Health Surabaya.
Jl Pucang Jajar Timur 10 Surabaya, Indonesia. Ph/Fax + 6231-5037095

²Department of Electromedical Engineering, Polytechnic of Health Ministry of Health Jakarta II.
Jl Hang Jebat III Blok F3 Kebayoran Baru, Jakarta Selatan Indonesia Ph/Fax +6221-726

*Corresponding author, e-mail: bgi_ps@yahoo.com

Abstract

ECG machine on the market, has a considerable cost, the technology used is still very complicated. In efficient and display ECG still not interconnect with other devices. In this study, the researchers designed ECG machine 12 channels to take advantage ATmega microcontroller technology, Graphic LCD 64x12, which can be obtained on the market at low prices, thus yielding a portable ECG apparatus, can interconnect with other devices and cheap. Objective is to design a ECG machine using ATmega microcontroller technology, by making a series of bio amplifier ECG, measuring the amplitude and frequency response bio amplifier, and make the ECG signal processing circuit with microcontroller, which can be displayed on a 128x64 graphic LCD or PC. To answer the research objectives, the design of the research is to use pure experimental research is the design of experimental series. The independent variable ECG phantom or human and the dependent variable is the ECG machine. While the design ECG machine through the stages as follows: circuit design, circuit testing and calibration output. The conclusion of this study: The result of the design of microcontroller ATmega program listings can be used transform and run the program to the ECG machine to know the number of heartbeats, a beep sound every wave R the ECG signal, displayed on the graphical LCD, PC, printed through a computer, and can be stored in computer.

Keywords: ECG, ATmega Microcontroller, Heart

Copyright © 2016 Institute of Advanced Engineering and Science. All rights reserved.

1. Introduction

ECG machines are standard equipment used to diagnose heart disease [1]-[3]. ECG machine is needed in health facilities such as: health centers, community Health centre and Hospital, even gave for monitoring can be used in the House. For the purposes of early detection of heart attack, it is necessary for the purposes of monitoring ECG machine or daily checks. ECG machine on the market, has the price is quite expensive, so it is not accessible to the public medium or small clinics in addition to the technology used is difficult to understand, if the device is damaged very difficult and many electronic circuits are secret. Technological knowledge microcontroller for ECG machine design has been done by several researchers, including microprocessor-based physiological signal monitoring and recording system for ambulatory subjects (Kao, 1995) [4] Development of a Portable ECG linux-Based Measurement and Monitoring System (Without Hsu, 2011) [5], Research of portable ECG Monitoring Device (Geng huang Yang, 2012) [6], Design of the intelligent simple Electrocardiograph (Sun, 2012) [7], Microcontroller-based data acquisition system for Heart Rate Variability (HRV) measurement (Akhter, 2012) [8], Two Low-Cost Solutions for Cardiac Mobile Monitoring (R.I. Gonzalez, 2008) [9], Novel compact micro strip low pass filter with sharp transition and improved stop band (Ping Juan Zhang, 2015) [10], Fast Distance Protection for Proximal Fault of EHV Transmission Line (Li Zhenkun, 2013) [11], Designing ECG mini one channel with graphic display LCD (Triwiyanto, 2014) [12].

The Problem from the research is currently still has the disadvantage that the data storage system and the measurement of only one channel can not be used to diagnose heart disease and not associated with a personal computer. Besides the price is expensive, the component commercially available.

The proposed solution to solve the problems found in previous research. Researcher trying to develop a ECG machine that can store more data and increase the measurement point to 12 channels, especially in the field of the measurement of frontal and transverse plane by utilizing appropriate technology which uses components of microcontroller ATmega, LCD Graphic 64x12, RAM and SD Card which can be obtained on the market at low prices, so it can be designed as ECG machines are portable and inexpensive, and can connect with a personal computer by recording the signals of heart which does not differ with sophisticated equipment.

2. The Purposed of the design of ECG machne based on Microcontroller ATmega

The purpose of research to develop a system of ECG equipment that can store more data and increase the measurement point to 12 channels, utilizing appropriate technology.

2.1. Research Purposes

General purpose : Design of ECG machine using ATmega microcontroller technology. Special purpose are :

- 2.1.1. Make a series of ECG signals intercepts,
- 2.1.2. Make a bio-amplifier circuit,
- 2.1.3. Creating a series of microcontroller circuit to circuit LCD graphic display and the Personal Computer (PC),
- 2.1.4. Make a design software program measuring heart rate (heart rate) and the ECG signal,
- 2.1.5. Measure heart rate response and the amplitude of the ECG signal 6. Perform calibration to see heart rate and amplitude of the ECG signal on graphic LCD and PC

2.2. Conceptual Framework

The conceptual framework describes how the research process runs in the form of a block diagram. Which can be explained as in Figure 1.

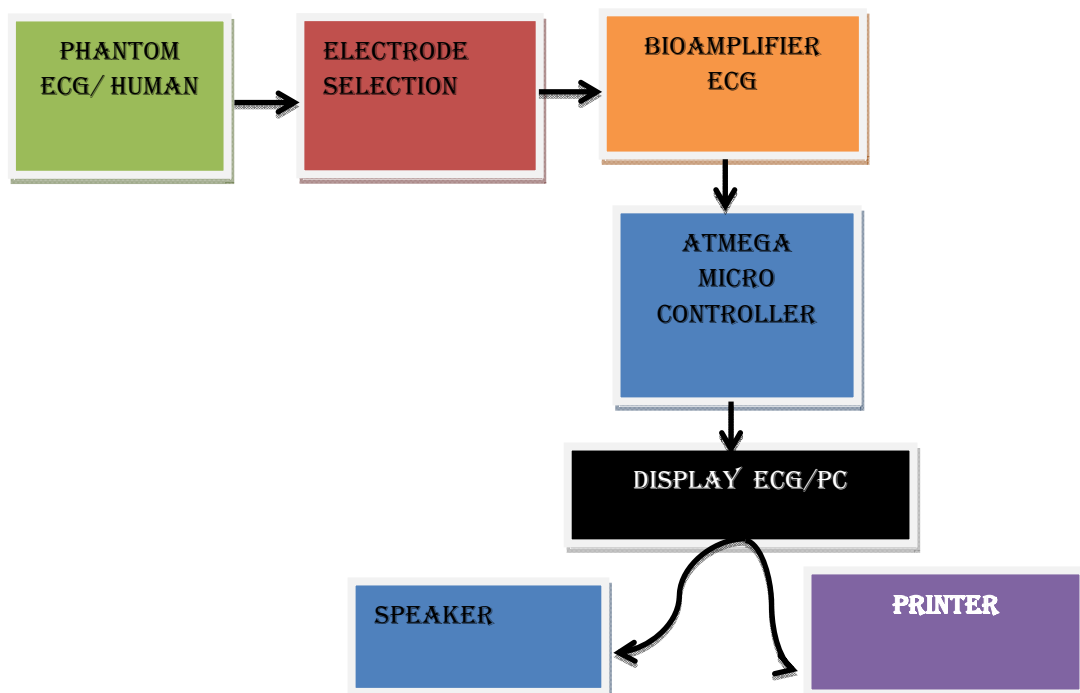

Figure 1. Block Diagram Research

Signal of bioelectrical ECG phantom or the human body has an amplitude very small tapped by the electrodes and then output from the electrode, an input circuit buffer that

functions as a series of buffer zone, the output of the circuit buffer will enter as an input block electrode selector (multiplexer) which serves to select the area of measurement or select the desired lead, the output of the multiplexer block as the input of the amplifier block Bio. So the signals can be recorded better than the block is also equipped with a series of filters. Bio amplifier is as input for the output of the microcontroller block. ATmega Microcontroller block serves as the signal processing of the circuit bio amplifier to both LCD display and Personal Computer.

3. Research Methodology

This type of research is research Quasi-Experimental, Variable: Independent variables in this study is the ECG signal and the dependent variable is ECG Machine. [13], [14] Location and Time Research: Location of research done at the Department of Electromedical Engineering Polytechnic of Ministry of Health Surabaya, Indonesia and research duration for 10 months, starting from January to October, 2015. Data processing and data analysis :

The results of the measurement of the heart rate from the design of ECG machine based on microcontroller ATmega will be analyzed by comparison with standard.

Then the researchers compared the results of measurements with calculations manually, the distance between waves R1 to R2 to note that the speed of 25 mm / min or phantom, the formula:

$$\text{Heart Rate (BPM)} = \frac{1500}{\text{Number of Small Box}} \text{ BPM}$$

Example: Researchers determine on phantom Heart rate listed in the phantom 30, the distance from R1 to R2 are 30 small boxes, then Heart rate can be calculated:

$$\text{HR (BPM)} = \frac{1500}{30} = 50 \text{ BPM}$$

4. Results and Discussion

4.1. Results

The result of this research is the design of ECG machine based on ATmega microcontroller (Figur 2). While the results of the measurement of heart rate by using the standard ecg phantom and measuring results p wave can be seen in Table 1- 3).

Table 1. Results of Measurement of Heart Rate (BPM) with a standard phantom 30 BPM

Set media	Personal Computer (BPM)				
	I	II	III	IV	V
LEAD					
Lead 1,2,3,	30	30	30	30	30
Lead AVR	29	30	30	30	30
Lead AVL	30	30	29	29	30
Lead AVF	30	30	30	30	29
Lead V1,V2,V3,V4,V5,V6	30	30	30	30	30

Table 2. Results of Measurement of Heart Rate (BPM) with a standard phantom 60 BPM

Set media	Personal Computer (BPM)				
	I	II	III	IV	V
LEAD					
Lead 1	60	60	59	59	60
Lead 2	60	60	59	60	60
Lead 3	59	60	60	60	60
Lead AVR	60	60	60	59	60
Lead AVL	59	60	59	60	60
Lead AVF	60	60	60	59	60
Lead V1,V2,V6	60	60	60	60	60
Lead V3	59	60	60	60	60
Lead V4	60	59	60	59	60
Lead V5	60	60	59	59	59

Table 3. The R wave amplitude measurement on an ECG Module

Set media	R wave measurement.					ECG Standard
	I	II	III	IV	V	Standard
LEAD						
Lead 1	13	13	13,05	13	13	13
Lead 2	20	20	20	20	20	20
Lead 3	5	5	5	5	5	5
Lead AVR	15	15	15	14,8	15	15
Lead AVL	3	3	3	3	3	3
Lead AVF	11,8	12	12	12	12	12
Lead V1	4	4	4	4	4	4
Lead V2	8	8	8	9	8	8
Lead V3	17,8	18	18	18	18	18
Lead V4	22	22	22	22	22	22
Lead V5	22	22	22	22	22	22
Lead V6	15	15	15	15	15,05	15

4.2. Discussion

The result of this research is the design of ECG machine based on ATmega microcontroller. How it works as follows: Input derived from phantom will be tapped by the electrodes. The output of the leads will be entered into a series of Low pass filter (Figure 2).

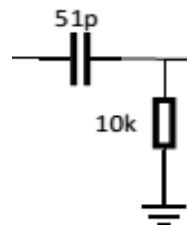

Figure 2. LPF Circuit

By entering a 10K Ohm resistance value and the value of the capacitor 10 pF then cut off frequency of the low pass filter circuit is 312 KHz. It serves as a high frequency filter that will pass. Each interception is equipped with Low pass filter circuit is composed of 12 filters. Output of Low pass filter will enter the buffer circuit (Figure 3). The buffer circuit consists of 12 buffer mounted on each lead.

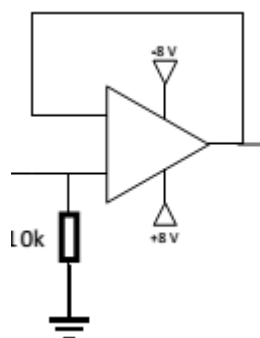

Figure 3. Buffer Amplifier

This circuit is very beneficial because it can be retrieved an amplifier with very high impedance input ($10 \cdot 10^{12}$ Ohms) and a very low impedance output ($10^{-3} \cdot 10^{-1}$ Ohm). that is approaching the ideal conditions.

The output of the buffer circuit will be entered into a series of images multiplexer. The multiplexer circuit functions as a switch option. Where from 12 lead will come out as output a signal in accordance with a selector switch selection. While the output of the multiplexer will enter Bio amplifier circuit will go into the microcontroller ATmega to be processed and the results are displayed on a computer or on the LCD graph. In Microcontroller ATmega will be processed by the application program Delphi [12].

The result between the measurement data and standard phantom will be compared using statistical calculations, then: 1. BPM: 30 BPM has a % error of 0,022,222 and U_a : 0,000324748.2. BPM: 60 BPM has a % error of -0.003888889 and U_a : 0.000550637. By looking at the results of the above calculations, the design of ECG machine based on ATmega Microcontroller still within the limits permitted tolerance values, because the limit value tolerance of 5%. In the same way, then the analysis can be used to analyze wave signal R. Namely: 1. The R signal lead 1 has an % Error of 0.000769 and U_a : 0.01. 2. R signal leads 2 has an % error of 0.538462 and U_a : 0. 3. R signal lead 3 has a % error of -0.61538 and U_a : 0. 3. 4. R signal lead AVR has a % error 150 769 and U_a : 0.04. 5. R signal lead AVL has a % Error of -0.76923 and U_a : 0. 6. The signal R lead AVF has a %error of -0.08% and U_a : 0.04. 7. R signal lead V1 has a % error of -0.69231 and U_a : 0. 8. R signal lead V2 has an% error of -0.38615 and U_a : 0.02. 9. R signal lead V3 has a % Error of 0, 384 615 and U_a : 0. 10. R signal lead V4 has an % Error of 0, 692 308 and U_a : 0. R 11.sinyal leads V5 has a % error 0.692308% and U_a : 0. R 12.sinyal lead V6 has a % Error of 0, 154 615 and U_a : 0.01. By looking at the value of% Error and Uncertainty still below 5%, it is feasible to use ECG module

5. Conclusion

Results of ECG machine based on ATmega microcontroller is used to measure heart rate, as having % error of 0.150769% level of uncertainty (U_a) most 0.04, still below the standard 5%. The design of each ECG R wave appears to 0.002628889% error and uncertainty (U_a) 0.000605608, still below the standard 5%, so the design of ECG machine baesd on ATmega microcontroller feasible to use. The result of the design of microcontroller ATmega program listings can be used transform and run programs based ECG module ATmega microcontroller with a pull to see the number of heartbeats, a beep sound every wave R and the ECG signal. The results of this ECG design can be displayed on the graphical LCD, PC, printed through a computer and can be stored in the computer.

References

- [1] Carr Jos eph. *Introduction to Biomedical Equipment Technology*. New Jersey: Prentice Hall. 1998.
- [2] Gabriel JF. *Fisika Kedokteran*. Jakarta: EGC.1995.
- [3] Khandpur. *Biomedical Instrumentation Technology and Applications*. United State of America: McGraw Hill. 2005.

- [4] Kao et al. *Microprocessor based physiological signal monitoring and recording system for ambulatory subjects*. China: Medical and Biological Engineering & Computing. 1995.
- [5] Tan-Hsu Tan. Development of a Portable Linux-Based ECG Measurement and Monitoring System. *Journal of Medical Systems*. 2011; 35(4): 559-569.
- [6] Genghuang Yang. *Research of portable ECG Monitoring Device*. Lecture Notes in Electrical Engineering. 2012; 121: 213-220.
- [7] Jie Sun. *Design of the Intelligent Simple Electrocardiograph*. Advances in intelligent and soft computing. 2012; 129: 157-162.
- [8] Nazneen Akhter, Jinan Fadhil Mahdi, Ganesh R Manza. Microcontroller based data acquisition system for Heart Rate Variability (HRV) measurement. *International Journal of Applied Science and Engineering Research*. 2012; 1(4).
- [9] RI Gonzalez. *Two Low-Cost Solutions for Cariac Mobile Monitoring*. World Congress on Medical Physics and Biomedical Engineering. Munich. 2009.
- [10] Ping Juan Zhang. Novel compact micro strip low pass filter with sharp transition and improved stop band. *Telkomnika ieas Journal*. 2015; 13(1): 85-90.
- [11] Li Zhenkun, Ji Hui, Fu Yang. Fast Distance Protection for Proximal Fault of EHV Transmission Line. *Telkomnika Indonesia ieas Journal*. 2013; 11(2): 615-622.
- [12] Triwiyanto. *Perancangan ECG mini satu chanel dengan tampilan grafik LCD*, Surabaya, 2014.
- [13] Sugiyono. *Metode Penelitian Kuantitatif Kualitatif dan R & D*, Bandung: ALFABETA. 2008.
- [14] Katarzyna Cieslak-Blinowska. *Practical Biomedical Signal Analysis using MATLAB*, Spanis: Press. 2010.