

EUROPEAN RECOVERY SYSTEM (ERS)

Marcus Hörschgen⁽¹⁾, Horst Pfeuffer⁽²⁾, Thomas Janke⁽³⁾

⁽¹⁾E-mail: Marcus.Hoerschgen@dlr.de, Phone: +49 8153 28 2172, Fax: +49 8153 28 1344
DLR-RB-MR, Postfach 11 16, 82230 Weßling

⁽²⁾E-mail: Horst.Pfeuffer@kayser-threde.com, Phone: +49 89 72 495 221, Fax: +49 89 72 495 483
Kayser-Threde GmbH, Perchtingerstr.5, 81379 München, Germany

⁽³⁾E-mail: Thomas.Janke@dlr.de, Phone: +49 8153 28 2722, Fax: +49 8153 28 1344
DLR-RB-MR, Postfach 11 16, 82230 Weßling

ABSTRACT

Up to the TEXUS-44 microgravity research mission, successfully launched in February 2008, the payloads of the TEXUS vehicles were exclusively equipped with the Magellan (former Bristol Aerospace Ltd.) ORSA recovery system, integrated into the ogive nose cone. With the intention to gain more independency from the North American market and the inherent procurement and ITAR regulations problems, the European Space Agency (ESA) has taken initiative to contract industry for the development and built-up of a new European Recovery System (ERS) in 2006. For the design, manufacturing and qualification task sharing, a cooperation of DLR Moraba and the Kayser-Threde GmbH has been initialized.

The ERS is designed to recover payloads of up to 450 kg mass and 17 inch (438 mm) diameter by a two-stage subsonic parachute system. It features a separating ogive nose tip with a forward deploying recovery parachute. The assembly incorporates a 3:1 fineness ratio ogive which forward portion is ejected exo-atmospherically to permit subsequent parachute recovery system operation. The aft ogive houses the parachute system, autonomous redundant pyrotechnic ignition system, housekeeping electronics, TM interface, beacon system, camera system and pyrotechnic and electronic batteries.

The parachute system activation is controlled by barometric switches on the descent trajectory at a nominal altitude of 15 kft (4.6 km) in the combination of an electronic timing activation unit (ignition unit). Together with the heat shield ejection the drogue parachute is deployed and the payload is mainly stabilized from flat spin and decelerated. After complete stabilization the drogue parachute is separated and extracts the main parachute out of the deployment bag. At fully opened main parachute the final sink rate is around 8 m/sec.

1. INTRODUCTION

The TEXUS program is a German Aerospace Center (DLR) and European Space Agency (ESA) funded sounding rocket program. TEXUS is conducted by Astrium Space Transportation as industrial prime.

Kayser-Threde GmbH in corporation with the DLR Moraba provides the TSM service module and the ERS recovery system.

The TEXUS vehicle consists in general of:

Rocket Motor System (VSB-30 sounding rocket)

- S31 first stage with boost adapter, spin-up system, fin assembly
- S30 second stage with separation and despin system, payload adapter, fin assembly

Payload

- Cylindrical experiment modules
- Service system (TSM)
- Recovery system (ERS)



Figure 1. TEXUS Vehicle Configuration

After the burn phase of the rocket motors, despin and motor-payload and nose tip separation, the TEXUS payload provides with apogees of 270 km around 6 minutes of microgravity environment.

2. SYSTEM ARCHITECTURE

2.1. ERS Overall Configuration

The ERS is mounted onto the forward end of the 438 mm cylindrical payload with data interface to the service system. The GPS antenna is placed on top of the ERS forward ogive containing the tip separation mechanism, followed by the ERS aft ogive, equipped with electronics, batteries and the parachute recovery system. The complete system mass is 55.5 kg at a total length of 1355 mm.

2.2. Forward Ogive Assembly

The forward ogive part consists of a forged aluminium ogive with a total length of 883 mm. It comprises the

GPS nose tip antenna in front with a conical adapter, the aluminium ogive structure, a pyrotechnically actuated high pressure gas manacle ring release and plunger separation system, the forward manacle flange and a releasable manacle ring. Fig. 2 illustrates the main components.

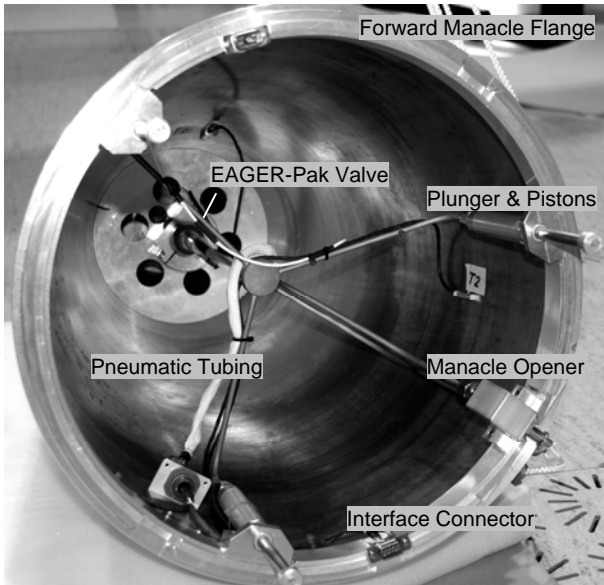

Figure 2. ERS Nose Tip Configuration

The nose tip is attached to the payload by the segmented manacle ring, which parts are flexibly connected and fixed by a locking mechanism that is released by a pneumatically actuated piston. The manacle ring release and the forward ogive ejection are initiated by a pyrotechnic valve.

2.3. Aft Ogive Assembly

The aft ogive part consists of an up to 6 mm thick Ni-coated aluminium alloy, machined from a rolled one-piece raw material. The forward manacle flange is used for the fixation of the forward ogive by the manacle ring. Behind that, a heat shield protects the parachute inside the parachute compartment from hot gases outside during the re-entry. The heat shield release mechanism, interface connectors and a camera system are implemented to the flange ring. Fig. 3 shows a view inside the aft ogive.

The lift-off switch, mounted to the cylindrical part of the aft outer structure, initializes the system in parallel to acceleration sensitive g-switches. The rear part of the aft ogive contains the ignition unit, barometric system, main parachute brackets, battery packs, and a beacon system assembled on the mounting plate. The main parachute, released by the stage line cutter system, is attached to the main parachute brackets. The two redundant system battery packs can be installed through access doors.

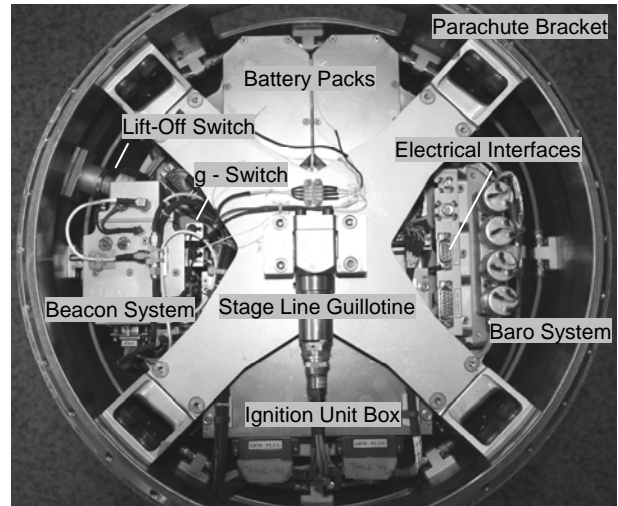

Figure 3. ERS Aft Ogive Configuration

3. SYSTEM DESIGN DETAILS

3.1. Forward Ogive Design Details

3.1.1. GPS Tip Antenna

The GPS tip antenna comprises an antenna thermal protection radome made of PEEK material, the helix antenna and an incorporated low noise amplifier. The antenna is mounted on top of an aluminium cone frustum that is attached with 6 M5 screws to the forward ogive and thermal protected with FIREX RX-2376 ablative material after the assembly with the cone structure. The length of the complete GPS tip is 166 mm. The antenna is operating in RHC polarization with semi-hemispheric coverage at GPS reception frequency L1. An integrated amplifier is providing 20dB gain and requires a 5 Volts DC power supply delivering 20 mA current.

3.1.2. Nose Cone

The outer structure of the forward ogive is made of forged AlMg1 aluminium alloy with an average wall thickness of 2.2 mm and an ogive ratio of 1:2.95. For heat protection the complete forward ogive is coated with 1.3 mm FIREX RX-2376 ablative paint which is activated at temperatures of 140 °C and maintains a constant structure temperature level of 120 °C until complete ablation.

The manacle flange is made of aluminium alloy with anodized surface. The manacle interface is milled as a high precision part guaranteeing perfect fit of the manacle clamp band. The separation plunger and manacle ring opener are attached to the manacle flange. Two floating diametrically installed Canon D-Sub 9P type connectors are used as electrical interfaces to the GPS antenna and EAGER-PAK valve. Fig. 4 shows the single components and a cross section view of the nose cone.

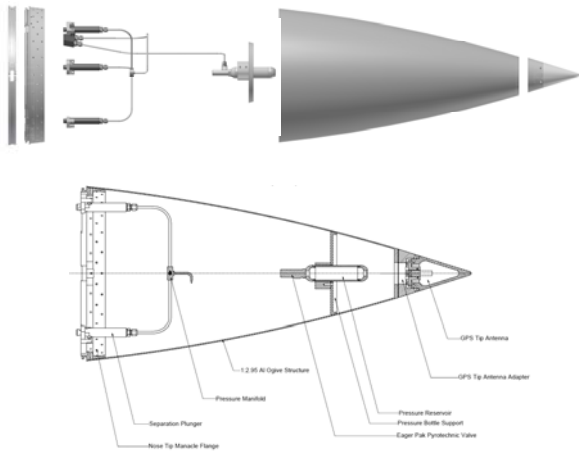

Figure 4. Nose Cone Assembly

3.1.3. Manacle Release and Separation System

The manacle ring release and separation system comprises the 80 cm³ gas reservoir, filled with Nitrogen at 250 bars, inclusive filling valve and EAGER-PAK pyrotechnic valve, the pipeline system including distributor, the manacle ring opener and the separation plungers.

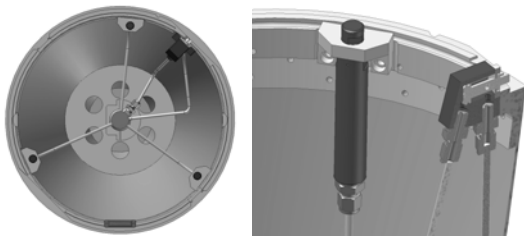

Figure 5. Opening and Separation System Details

After initiation of the pyrotechnic valve the pipeline downwards to the manacle ring opener is pressurized and the opener piston releases the manacle lock. When the piston is fully extracted a pressure outlet towards the pressure distributor becomes unblocked. Via the pressure distributor and three identical pipes the three separation pistons are deployed simultaneously pushing the forward ogive away. The pressure reservoir is made of a St-52 steel cylinder with WIG welded end caps. The Conax EAGER-PAK sub-assembly is widely used in aerospace systems for actuation of pneumatic devices by pyrotechnic driven valves. The pyrotechnic charge is initiated by two bridge wires for redundancy.

The manacle ring opener consists of a piston installed in a small housing and providing a maximum stroke of 24 mm for dynamically opening of the manacle lock and ensuring safe release of the complete ring. The mechanical interfaces for pressure inlet and outlet are 3/8" UNF threads. When installed into the forward ogive assembly the piston of the manacle ring opener

produces an opening force of 3.8 kN. For the separation of the forward ogive three pneumatic plungers are used acting on the heat shield of the aft ogive. The separation plungers consist of a cylindrical housing, piston with end cap and a support for attachment to the structure. Pneumatic tubes via the pressure manifold are used for the distribution of the pressurized gas to the manacle release mechanism and the separation pistons as well.

3.1.4. Manacle Ring

The manacle ring is the mechanical connection between the forward and the aft ogive that is released by the manacle ring opener. Different to the payload motor connecting manacle joints this manacle ring is conical in outer geometry adapted to the ogive radius to reduce protuberances and heating. The manacle ring consists of four segments made from aluminium alloy, connected by steel joints, a releasable lock and a turnbuckle. For heat protection the manacle ring is silicone covered on the outside.

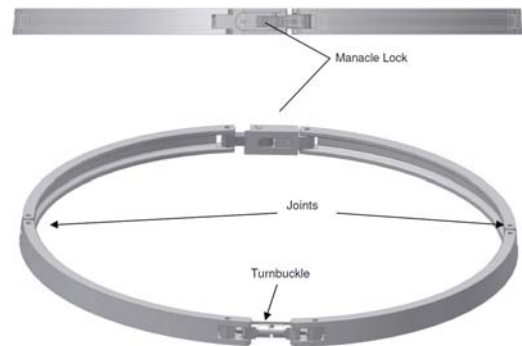

Figure 6. Manacle Ring

3.2. Aft Ogive Design Details

3.2.1. Heat Shield

The heat shield consists of a 9 mm aluminium structure with a 2.5 mm FIREX RX-2373 thermal protection layer, injection welded to the outer surface and a 2.5 mm cork insulation for thermal and mechanical protection of the parachute inside. Three parachute brackets are fixed 120 degrees apart on the rear side for attachment of the drogue parachute extraction lines. The heat shield is sealed by a Ø 324 mm x 4 mm silicone O-ring and fixed by two 1.5" screws.

3.2.2. Heat Shield Gun Assembly

The heat shield deployment gun has a dual function, both fixing and deploying the heat shield. With ignition of the two HOLEX 6201 type pressure cartridges the expanding gas pushes a stainless steel piston onto the heat shield, shears the heat shield attachment screws and forces the heat shield away from the parachute container. Details are depicted in the following Fig. 7.

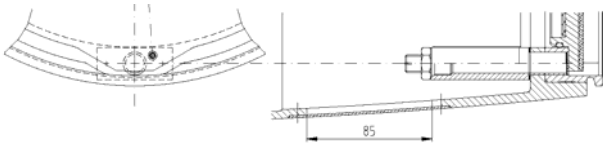

Figure 7. Heat Shield Gun Assembly

3.2.3. Interface Connector Assembly

The electrical interfaces to the pyrotechnics, the GPS tip antenna and a status tip break wire are realized via two 9-pole standard and mixed D-Sub type interface connectors. Temperature sensors in the nose tip are also optional.

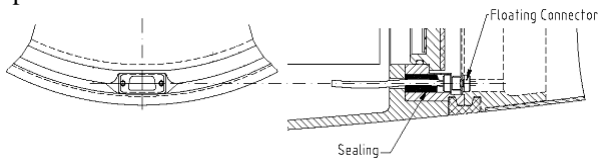

Figure 8. Interface Connector Assembly

3.2.4. Video Camera Assembly

An industrial WAT-260 video camera is mounted to the aft ogive with a sealing ring into a closed container, similar to the shape of a heat shield gun assembly. For the protection of the camera lens it is covered with a slide of glass.

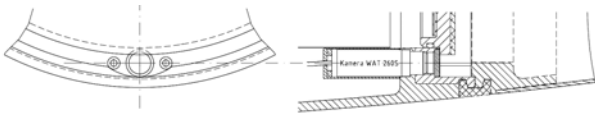

Figure 9. Camera Assembly

3.2.5. Aft Ogive Structure

The aft ogive is built from 6 mm aluminium alloy AlZn4.5Mg1, temperature treated and machined from a forged one-piece raw material. Thermal analysis has shown that with this structure thickness additional thermal protection inside and outside are not required.

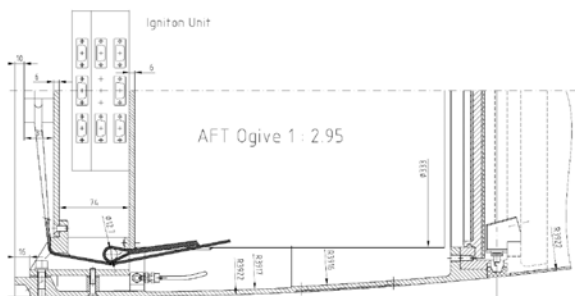

Figure 10. Aft Ogive Structure

The lift-off switch is mounted to the cylindrical part of the aft outer structure. The following Fig. 10 shows the mechanical outline of the aft ogive outer structure. The integrated length is 493 mm. Four access doors are incorporated for the mounting of the main parachute attachment bolts, the arming of the ignition system by means of arming connectors, the mounting of the ignition circuit and ignition electronic batteries and the installation of the heat shield pressure cartridges. The parachute canister inside the aft ogive is built from 0.8 mm aluminium sheet and contains and protects the parachute system.

3.2.6. Parachute System

The parachute system in packed state has a diameter of 330 mm and measures 330 mm in height. The parachute system comprises two stages and is contained completely in the parachute canister, fixed to the main parachute brackets and attached with the drogue parachute deployment bag attachment lines to the heat shield. The parachute is designed to provide a final sink velocity of approx. 8 m/s for a 450 kg payload. The first stage consists of a 20° conical ribbon parachute with a nominal reference area of 7.9 m² which serves as a stabilization and main breaking device from rough flat spin re-entry motion. The drogue parachute deployment bag is attached to the rear side of the heat shield and is extracted with heat shield jettison initiating the recovery sequence.



Figure 41. Main Parachute

Subsequently the reefed drogue parachute is deployed from the packing bag while the main parachute is fixed

with the main harness to the main parachute brackets. The drogue parachute is designed for a maximum activation velocity of 150 m/sec in 15 kft activation altitude. For the first 10 seconds the parachute is reefed to 35%. After the total action time of 25 sec, controlled by the ignition unit, the payload is stabilized and decelerated to approximately 40 m/sec without exceeding load levels of 3.5 g during opening shocks.

The second stage consists of a cross canopy parachute with a nominal reference area of 147 m² also reefed for 10 seconds to 8%. The cross canopy provides very stable final sink conditions avoiding violent payload movements hence reducing landing damages. In standard missions the parachute is activated at velocities around 50 m/sec by cutting the drogue parachute harness with a pyrotechnically operating guillotine knife, which is fixed on the center of the rear side of the parachute system container. The released drogue parachute drags and deploys the main parachute package by means of an extraction line. On fully opened main parachute the final sink velocity at landing point is below 8 m/sec. The opening loads on the main parachute are below 2.5 g. Fig. 11 shows the fully open parachute stages seen from on-board video camera.

3.2.7. Stage Line Cutter Assembly

The stage line cutter assembly consists of a solid aluminium cross attached to the main parachute brackets on the rear side of the parachute compartment base plate, atop the recovery system electronics.

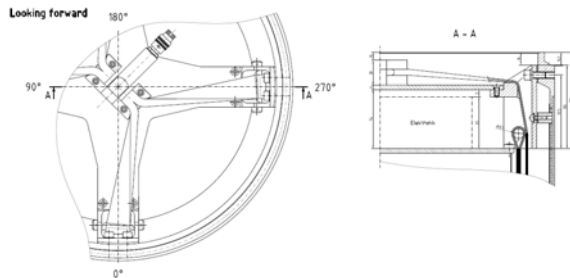

Figure 52. Stage Line Cutter Assembly

The stage line guillotine operated by a HOLEX 6201 pressure cartridge is mounted on top in the center of the cross.

3.2.8. Barometric System

The barometric system consists of two sets of two different Precision Sensors E28C type barometric switches, mounted to a solid aluminium plenum block. The barometric block is with two lines symmetrically connected to a ring line that combines the pressure of six circumferentially placed pressure sensing ports, mounted to the aft ogive structure. The pressure ports consist of 2 mm holes through the structure for ambient

pressure measurement. A 5 kft nominal open switch serves as a ground safety device for the complete pyrotechnic system and a 15 kft switch activates the recovery sequence. The plenum pressure is monitored with a MPX5100 type pressure sensor.

3.2.9. Battery Packs

The power for the ignition circuitry and the ignition electronics is provided by two redundant battery packs.

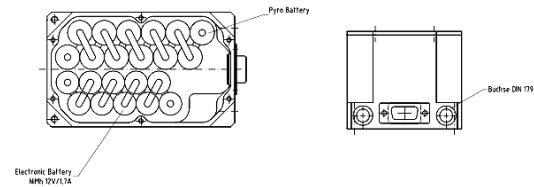

Figure 63. Battery Pack

Each pack contains 12 Saft VHT type AA Ni-MH rechargeable battery cells for the ignition circuitry and 10 VH AAH 1700 Ni-MH high energy cells for the ignition unit electronics. The charging of the batteries is performed with an external battery charger after dismount of the battery assembly. Remote charging in the launcher is not foreseen but in principle possible.

3.2.10. Ignition Unit

The recovery system is pre-armed via the umbilical, consequently activating the recovery system electronics and initialized by a separate lift-off switch. The ignition unit (IU) controls all ignition relevant electrical functions inside the ERS and has a RS422 serial interface to the service system for housekeeping data transmission. The connection of external batteries, lift off switch, barometric switches, pyrotechnical devices and status monitoring break wires are realized by standard D-Sub type connectors.

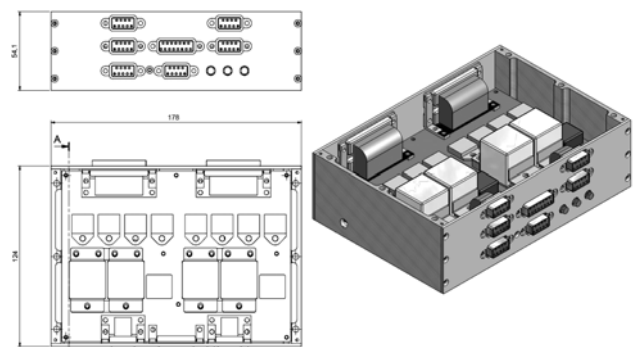

Figure 74. Ignition Unit

The IU is a fully redundant system, except all micro controller related circuitry, which has only a monitoring but no control function. The IU consists of a redundant

electronics card and a redundant power card stacked together and mounted in an aluminium box with dimensions of 178×124×58 mm. The IU is built up of two independent but identical, redundant circuits (Side A and Side B). Enabling and disabling of the IU is performed by a dedicated GSE arming-function via the service system umbilical. The ignition sequence is fixed programmed inside the CPLD logic. It is initiated by dedicated lift-off and g-switches. Fig. 15 shows the block diagram for only one part of the redundant ignition unit system.

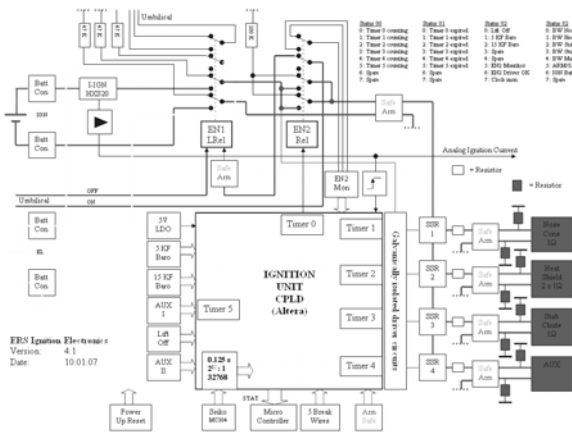

Figure 8. Ignition Unit Block Diagram

Each redundant circuit is served by its own pyrotechnic battery pack (VPB). The logic circuits are not supplied from the pyrotechnic battery, but fed by a separate electronics battery (VEB). In total there are four battery packs, two VPB and two VEB. Control, sequencing and inhibiting of the pyrotechnics timing is realized in the CPLD. Four timer outputs are low pass filtered and then routed from the electronics card to the power card. The driving power to the solid-state relays is routed through two relays, providing additional security against unintentional activation of the pyrotechnics. The first relay (EN1) in the chain is controlled via a separate 28V power source provided through the umbilical; the second relay (EN2) is controlled via the Timer 0 output from the CPLD. The minus terminal of the pyrotechnics battery is only routed through the EN1 relay. Bleeder resistors between the SAFE/ARM connector and the pyrotechnic connector provide protection against electrostatic charge when the pyrotechnics are connected to the IU. Arming of the pressure cartridges is performed by safety and arming connectors. A microcontroller circuit is also included inside the IU providing housekeeping information for further processing via the serial interface.

3.2.11. Beacon System

The autonomous beacon system for easy location of the payload on ground consists of a beacon box, transmitter,

barometric switch, battery, electronics and antenna. Fig. 16 shows the outline of the beacon box with the beacon transmitter mounted aside.

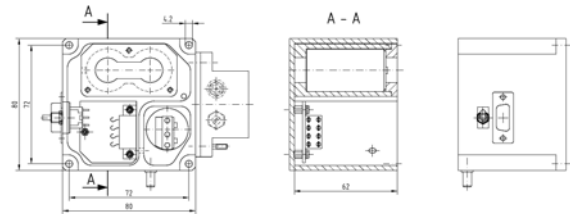

Figure 96. Beacon Box

The beacon electronics is contained inside the beacon box and has an electrical interface to the externally placed beacon transmitter. The activation of the beacon transmitter is performed by a 20 kft (6.1 km) barometric switch on descent, inhibited by a timer controlled auxiliary output from the ignition unit and activated at the end of the mission (T+750 sec) with payload on the parachute. The beacon system comprises a Micro Electronics Model 505-6 type beacon transmitter, operating on UHF frequency at 244.05 MHz. The beacon battery consists of two SL-770 Li/SOCI2 primary cells, connected in series to provide a total voltage supply of 7.2 Volts for the beacon and also the parachute video camera. The beacon antenna, directly connected to the recovery beacon, is routed between parachute container and ERS aft structure to the top of the parachute container. The radiating antenna elements are placed on top of the drogue parachute and are extracted with the heat shield and drogue parachute deployment.

4. MISSION

The ERS has been successfully flown on the TEXUS-44 vehicle for the first time, launched at Esrange, Sweden, at 10:30:00 UT on February 7, 2008. The ERS has been developed in a joined co-operation between DLR Moraba and Kayser-Threde and is also used as the recovery system for the MASER program. So far, three successful flights have been recorded and two upcoming missions are prepared.

5. REFERENCES

1. W. Saedtler and M. Hörschgen, *ERS System Design Description*, Munich, Germany, 2007.
2. T. Janke, *Ignition Unit Handbook System Description 1.0*, Oberpfaffenhofen, Germany, 2007.
3. T. Janke, *Ignition Unit Handbook ERS 1.0*, Oberpfaffenhofen, Germany, 2007.
4. M. Hörschgen, *TEXUS Parachute System Layout 3.4*, Oberpfaffenhofen, Germany, 2007.