



Strathprints Institutional Repository

Kelly, Nicolas and Tuohy, Paul Gerard (2013) Simulation based performance assessment of phase change enhanced thermal buffering for domestic heat pump load shifting. In: 13th Building Simulation Conference, BS2013, 2013-08-25 - 2013-08-28. ,

This version is available at <http://strathprints.strath.ac.uk/44666/>

Strathprints is designed to allow users to access the research output of the University of Strathclyde. Unless otherwise explicitly stated on the manuscript, Copyright © and Moral Rights for the papers on this site are retained by the individual authors and/or other copyright owners. Please check the manuscript for details of any other licences that may have been applied. You may not engage in further distribution of the material for any profitmaking activities or any commercial gain. You may freely distribute both the url (<http://strathprints.strath.ac.uk/>) and the content of this paper for research or private study, educational, or not-for-profit purposes without prior permission or charge.

Any correspondence concerning this service should be sent to Strathprints administrator: strathprints@strath.ac.uk

SIMULATION BASED PERFORMANCE ASSESSMENT OF PHASE CHANGE ENHANCED THERMAL BUFFERING FOR DOMESTIC HEAT PUMP LOAD SHIFTING

Nick Kelly and Paul Tuohy

Energy Systems Research Unit, Department of Mechanical and Aerospace Engineering,
University of Strathclyde, Glasgow, Scotland

ABSTRACT

In this study, the feasibility of using thermal buffering enhanced with phase change material (PCM) to enable heat pump load shifting for a typical UK dwelling was investigated by comparing the performance of a buffered, load-shifted heat pump against a reference case. The impact of load shifting on a larger population of heat pumps was also explored.

The results indicate that with adequate buffering the operation of a domestic heat pump can be wholly moved to off-peak periods without adversely affecting space or hot water temperatures. The volume of the buffer required could be more than halved using PCM. However, load shifting was associated with a significant energy penalty that negated any economic benefits accruing from a switch to off peak electricity. The study also showed that load shifting of populations of buffered heat pumps could exacerbate peak loading on the electrical network rather than reducing it.

INTRODUCTION

In the UK, heat pumps are often viewed as a means to deliver low-or-zero carbon heat to the domestic sector (e.g. Hewitt, 2012), provided that the UK electricity supply decarbonises in the future. However, if significant numbers of heat pumps were retro-fitted into the UK housing stock then the peak electrical load in the electricity distribution system could be substantially increased in areas where heat pumps were concentrated. This could lead to problems such as low voltages and cable overloading at times of peak heat pump operation in the mornings and evenings, resulting in the need for significant and expensive network reinforcement or even infrastructure replacement. However, if sufficient local thermal buffering was provided to enable the operating time of a heat pump to be shifted outside peak electrical demand periods then such a scenario might be avoided. However, a shift in heat pump operating time could potentially cause problems for the end-user such as low space temperatures during occupied periods or low hot water temperatures.

A study by Hong et al., (2013) examined the flexible operation of air source heat pumps (ASHP) retro-fitted into current and future UK dwellings. In their

study, the limit of the heat pumps' operational flexibility was dictated by the service delivered to the end user: any shift in heat pump operation should have a minimal effect on delivered space or hot water temperatures. Using these criteria, Hong et al. indicated that heat pump operational flexibility was limited to between 1 and 2 hours in systems without thermal buffering. The same authors also demonstrated that more substantial shifts in heat pump operating times of up to 6-hours were feasible, but only with the addition of significant quantities of hot water thermal buffering (up to 500 L) and only with the building fabric insulated to passive house standards. The authors themselves pointed out that upgrading all houses to such exacting insulation standards may not be possible and that accommodating thermal buffering of this size could be problematic, particularly in smaller dwellings which constitute much of the UK housing stock (Palmer and Cooper, 2011).

Following-on from the work of (Hong et al, 2013), this study had three basic aims. Firstly, the feasibility of using PCM-enhanced thermal buffering to provide heat pump load shifting for typical UK dwellings was investigated. The second aim was to investigate the energy, environmental and economic performance of the load-shifted heat pump compared to the case with no load shifting and no buffering. The final aim was to assess the impact of thermal buffering and load shifting on a larger population of heat pumps.

The basis of this investigation was an integrated ESP-r model (ESP-r, 2013) of a larger, detached UK dwelling (Beyer and Kelly, 2008) featuring an ASHP heating system. This was used to investigate the potential for thermal storage augmented with PCM to provide practical, volumetrically efficient thermal buffering and load shifting in a larger dwelling type, which accounts for approximately 30% of the UK housing stock.

MODEL DETAILS

The detached dwelling model used in this study is stereotypical of the UK stock (Palmer and Cooper, 2011), with a usable floor area of 136 m² spread over an upper and ground floor. The building features three thermal zones: a loft space and two composite zones describing (respectively) the spaces hosting active occupancy such as the living room and

kitchen; and those spaces that have low occupancy rates or that are occupied during sleeping hours such as bathrooms and bedrooms. This form of model captures the key thermodynamic characteristics of the building's performance and has been deployed successfully in other studies (e.g. Clarke et al., 2008).

Table 1 Thermal characteristics of the main building elements.

Fabric element	'U'-value (W/m ² K)
Glazing (14mm gap)	3.03
External walls	0.26
Ground floor	0.121
Upper floor ceiling	0.129

The fabric of the building was subject to an upgrade, with 300 mm of insulation between the loft space and the occupied areas of the building; 60 mm of cavity wall insulation and 300 mm of insulation between the occupied area of the building and the void under the floor. This upgrading follows on from the findings of Hong et al. (2013) who indicated that without fabric improvements, the volume of thermal storage required for load shifting becomes infeasible, especially in smaller dwellings. The thermal characteristics of the main fabric elements are shown in Table 1. The average air leakage used in the model is 0.5 air-changes-per-hour, which is typical of newer dwellings in the UK (Johnston et al, 2012). The dwelling was assumed to be occupied by a family of four with active occupancy between 07.00-09.00 and 17.00-23.00; the occupants were assumed to be sleeping between 23.00-07.00 and outside of these periods the house was unoccupied.

The dwelling model was augmented with both unbuffered and buffered air source heat pump (ASHP) heating system variants (Figures 1 and 2, respectively). The ASHP has a nominal 11kW of thermal output. In the buffered system, a circulation pump transferred the stored heat from the buffer tank to the heating and hot water circuits. The system variants shown could be retro-fitted into many existing UK detached dwellings as a direct replacement for the boiler-based heating systems found in 90% of UK housing (Palmer and Cooper, 2011). However, the radiators would need to be resized for the lower flow temperature delivered by the heat pump modelled here of approximately 55°C (compared to water temperatures of up to 80°C often seen in boiler-based systems [Palmer and Cooper, 2011]).

The performance of the ASHP algorithm used in this study has been verified using field trial data, as described by Kelly and Cockroft (2012).

The tank algorithm used in this study to represent both the buffer and domestic hot water (DHW) tanks (Padovan and Manzan, 2013) accounts for

stratification and parasitic losses to the environment. The model can accommodate variable numbers of phase change modules and so can be used to represent sensible thermal buffering as well as buffering incorporating different percentages (by tank volume) of PCM.

As part of this study this study, the quantity of PCM, and the volume of the buffer tank were both varied to determine the amount of thermal buffering required to instigate load shifting of heat pump operation from peak to off-peak periods. The PCM used was a commercially available inorganic hydrated salt with the characteristics shown in Table 2; this material was selected as the best-fit match for the operating characteristics of the heat pump, enabling the buffer to operate in the phase change range and making best use of the material's latent heat.

The time-varying draw from the domestic hot water (DHW) tank was generated using a high-resolution algorithm based on that developed by Jorden and Vagen (2005) that calculates hot water draws at 1-minute resolution. The nominal draw used with the model, of 120 L/day, is consistent with the hot water use of a family of four (Knight and Ribberink, 2008).

Table 2 Selected characteristics of the phase change material (PCM Products, 2012).

Latent heat J/kg	210,000
Melting temperature °C	48
c solid J/kgK	2410
c liquid J/kgK	2410
ρ solid kg/m ³	1600
ρ liquid kg/m ³	1666

The control strategy adopted for the heating system differed depending upon whether a buffer tank was present. With a buffer tank, the ASHP was operated in an attempt to maintain the buffer outlet temperature between 50 and 55 °C, (on/off control with a 5°C dead band). The circulating pump then provided heat to the hot water tank and heating system if required. Ideally, the DHW tank was maintained between 43-45°C¹ and the space temperatures within the living zone were ideally to be maintained between 19 and 21°C, both using on/off control. The heating system was controlled with hot water priority: so that when the water tank temperature was below 43°C, all of the flow from the buffer tank heated the DHW tank. Only when the DHW tank reached 43°C was any hot water supplied to the heating circuit. With the unbuffered system, the ASHP was controlled directly in an attempt to maintain the conditions indicated above in the DHW

¹ The focus here is on the heat pump operation and this study does not consider secondary heating systems that may be used for boosting hot water tank temperatures e.g. for sterilisation / legionella control etc.

tank and living space. The hours of operation of the heating system are discussed later in the load shifting section. These control settings were derived from experience gained from field trials with other ASHPs (Kelly and Cockroft, 2012).

METHODOLOGY

Investigating PCM-enhanced Buffering

To determine the amount of thermal buffering needed to support radical heat pump load shifting whilst not adversely affecting the end-user through the occurrence of low space and hot water temperatures, the operating times of the heat pump were set back to off-peak demand periods. At the same time, the volume of the thermal buffer was varied from 300-1200 L and the percentage of PCM in the thermal buffer (by volume) was varied from 0% up to 70%. Above this percentage of PCM, the space remaining in the tank for heat exchangers becomes too restrictive.

The off-peak periods of heat pump operation correspond to the UK Economy-10 tariff (Economy 10, 2012), which offers lower electricity prices (Table 3) between the hours of 00.00-05.00, 13.00-16.00 and 20.00-22.00. Constraining the heat pump to operate within these hours effectively meant that (other than 20.00-22.00) it operated when the house was unoccupied or when the occupants were asleep.

To assess the effects of load shifting, the performance of the buffered system was compared to the case with no load shifting, where the heat pump was connected directly to the heating circuit (Figure 1). The hours of heating operation were set to 06.00-09.00 and 16.00-23.00, corresponding to the periods of active occupancy within the dwelling plus one-hour of pre-heating at the beginning of each period. These times also coincide with the UK's morning and evening peaks of electrical demand between around 08.00-09.00 and 17.00-18.00 respectively (National Grid, 2012).

The simulations were undertaken for a winter week for a cool UK climate (North East Scotland), which constitutes a 'worst case scenario' under which the ASHP/buffer would be expected to operate. The simulations were run at a 1-minute time resolution, which allowed the nuances of the heating system operation such as heat pump cycling and control valve operation to be captured in the results.

The performance metrics extracted were the percentage of occupied hours during which zone space temperatures fell below 18°C and in which hot water temperatures fell below 40°C. The performance of the buffered system was deemed adequate if the thermal comfort and hot water temperatures closely matched those of the reference (unbuffered) system (i.e. within 1%): so, to the end-user there would be no difference between the buffered and unbuffered system performance. Other performance metrics extracted were the heat pump coefficient of

performance, its electrical energy consumption and the number of on-off cycles, all of which were affected by the use of thermal buffering and the alteration of the heat pump operating times.

Economic and Environmental Performance

The ASHP performance data was post-processed to determine the energy costs for the end user and the carbon emissions associated with the use of the heat pump. Table 3 shows the on and off-peak prices used (Economy 10, 2012).

Table 3 Economy 10 on and off peak energy costs.

Tariff	On-peak cost £GBP per kWh	Off-peak cost £GBP per kWh
Standard	0.1308	0.1308
Economy 10	0.1817	0.1053

To determine the impact on CO₂ emissions from heat pump load shifting, it was necessary to generate time-varying carbon intensity data using a technique similar to that employed by Hawkes (2010). Data on the generation-mix at each hour of 2011 was obtained from Elexion (2012) and this information along with the assumed carbon intensities for different generation types (Hawkes, 2010) was then used to calculate the average hourly CO₂ intensity for grid electricity using the following equation:

$$c_{ave}(t) = \frac{1}{P_{TOT}} \sum_{x=1}^n P(t)_x \Delta t \times c_x \quad (1)$$

Load Shifting a Population of Heat Pumps

Finally, multiple simulations were run to illustrate the effect of load shifting on a population of heat pumps serving a group of similar detached dwellings such as this could be found in many UK suburban housing estates (Thomson and Infield, 2007). This simulation required that variants of the detached dwelling and buffered ASHP heating system were developed. Using information from Shipworth et al, (2010), diversity was introduced into the operation of the different heat pumps and heating systems by changing the total heating operating time, start/stop time settings and heating set point. Additionally the dwelling occupancy levels, occupancy time and the infiltration levels were varied using data from Johnston et al, (2012). Two groups of simulations were run for buffered heat pumps, constrained to operate during off-peak periods and unbuffered heat pumps that could operate as heat was required.

RESULTS AND DISCUSSION

PCM-Enhanced Thermal Buffering and Buffered System Performance

Table 4 shows, for each of case simulated, the size of the sensible and PCM-enhanced thermal buffer required to shift heat pump operation to off-peak

periods, whilst achieving a similar occurrence of low operative temperatures and/or hot water temperatures as the reference case. A tank size of 500 L with 50% of the volume occupied by PCM enabled acceptable load shifting, whilst without PCM a buffer tank of 1200 L was required. Clearly, the addition of the PCM to the buffer tank offered a significant improvement in the volume of thermal buffering required for load shifting.

Figure 3 illustrates the impact of increasing the percentage of phase change material in the buffer tank and the corresponding reductions in the occurrence of unacceptable living room and hot water temperatures during occupied hours.

Comparing the buffered results to the unbuffered case it is clear that there was a significant energy penalty associated with load shifting. Whilst the PCM-enhanced buffer tank offered improved performance compared to hot-water-only buffering, the energy use over the simulated week was still 27% higher than in the reference case with no load shifting. The increase in energy use is attributable to a number of factors. Firstly, the COP of the buffered heat pumps was lower than the unbuffered case: the addition of an extra heat exchanger in the buffer tank between the ASHP and the heating system meant that the temperature at which heat was supplied needed to be greater in order to maintain similar conditions in the dwelling. Additionally, the load-shifted ASHP was operated during off-peak hours in the evening and early morning when outside air temperatures were lower; this, coupled with the higher supply temperatures required meant that the temperature difference across the heat pump is higher and so the COP was reduced. Secondly, whilst the buffer tank in these simulations was well insulated (with a heat loss coefficient of $1\text{W/m}^2\text{K}$) it was still subject to parasitic losses not present in the unbuffered case.

The addition of hot water-only buffering was beneficial with respect to the cycling of the heat pump. The large sensible store reduced cycling, which could have a beneficial effect on both maintenance requirements and the heat pump lifespan. With the PCM-enhanced thermal buffer there was also a reduction in cycling, though less pronounced than with the 1200 L tank.

Environmental and Economic Performance

Table 4 also shows the environmental performance of the reference and load-shifted heat pump systems. Interestingly, using the 2011 UK CO₂ intensity data, load shifting of the heat pump into off-peak periods resulted in increased CO₂ emissions. This occurred primarily because load shifting of the heat pump resulted in higher electrical demand and also because the difference in UK grid CO₂ intensity between peak and off-peak periods was small. Indeed, in winter the CO₂ intensity in off-peak periods was occasionally higher than during peak periods, mainly due to the significant quantity of coal-powered stations

providing base load; at peak load times in winter, more lower-carbon generation such as CCGT and pumped hydro came on-line, reducing the CO₂ intensity of electricity per kWh generated.

Table 4 also shows the cost associated with running the ASHP during peak and off-peak periods. When the tariffs shown in Table 3 were applied there was a pronounced cost penalty for the end user from load shifting: the additional electrical demand associated with load shifting was not adequately compensated for by the Economy 10 price differential between peak and off-peak electricity.

Network Impact of Multiple Buffered Heat Pumps

The final simulations undertaken assessed the performance of a population of 50 ASHPs. In the future, this number of heat pumps could easily be found connected to a single suburban substation. A total of 100 separate simulations were undertaken with both the buffered and unbuffered ASHP systems, with heat pump operating times, duration of operation, occupancy, the heating set point and dwelling infiltration levels varied to provide adequate load diversity.

Figure 4 shows the aggregate load-shifted and non-load-shifted demands from the 50 dwellings over a 24-hour period during the simulated winter week. Shifting the demand of all of the heat pumps to off peak periods radically alters the timing of the demand, moving it into the three Economy 10 time periods outlined previously. This has the effect of reducing the level of the pre-existing morning and evening demands around 07.00 and 18.00. However, it is also clear that load shifting has the unintended consequence of creating new and significantly increased peak demands within the constrained load shift periods, particularly 13.00-16.00 and 20.00-22.00. The reasons for these demand spikes are due firstly to the increase in each individual heat pump's demand caused by the use of buffering observed previously. More importantly, there was a pronounced demand synchronisation effect; this occurred when the majority of the heat pumps operated at the first possible opportunity after a period of enforced non-operation in order to recharge the depleted buffer tank. This produced the very evident surges in demand at 13.00 and 20.00 resulting in the level of peak pump demand almost doubling compared to where the heat pumps were allowed to operate in an unconstrained manner.

In an attempt to reduce the large peak demands, Figure 5 shows the aggregate demand if only 50% of the ASHPs were constrained to operate in off-peak periods. With this level of load shifting the demand profile was again significantly altered, with demand around the morning and evening peaks of 07.00 and 18.00 reduced. However, even with this reduced demand intervention, a new peak demand of approximately 150 kW occurred within the 20.00-

22.00 operating period, some 20kW higher than the previous peak with no load shifting. Similar problems have been observed in other load shifting studies e.g. (Moreau, 2011) and the result serves as a warning that the consequences of load shifting are not necessarily beneficial to the operation of an electrical network.

A potential solution to the problems with load shifting highlighted here is to broaden the off-peak time period within which the load shifted heat pumps can operate. For example, looking at the aggregate load, excluding heat pumps there are clear periods of low demand between 09.00 and 16.00 and again between 22.00 and 07.00. Coupling broader off-peak periods along with staggered heat pump operating times (i.e. assigning slightly different operating periods to individual heat pumps) should reduce the excessive peaks in heat pump demand seen here. Essentially, to reduce the potential impact of heat pumps on the network will require algorithms and systems for careful orchestration of individual heat pumps in addition to thermal buffering.

CONCLUSIONS

To study the ability of phase change material (PCM)-enhanced thermal storage to facilitate effective heat pump load shifting, a model of a typical UK detached dwelling complete with a buffered air-source-heat-pump (ASHP) heating system was developed.

The operation of the heat pump was restricted to off-peak periods and the volume of storage (with and without PCM) required to deliver adequate space and hot water temperatures was investigated for a cool and UK climate over a winter week.

Using PCM, the volume of the buffering required to load shift the heat pump to off-peak periods could be reduced by more than half without a deterioration in the space temperatures or hot water temperatures delivered to the end user.

However, the simulations also highlighted a 27% energy penalty associated with the use of PCM-enhanced buffering and load shifting. This was due to a reduction in the COP of the heat pump when operated with thermal buffering, and the introduction of buffering standing losses.

Analysis of the environmental performance of the load-shifted heat pump indicated that there was no environmental benefit to be gained from load shifting to off peak periods. Indeed due to the increased energy use from load shifting and peculiarities of the time-varying CO₂ intensity of the UK grid, CO₂ emissions were actually greater with load shifting.

Similarly, applying UK off-peak prices to the load shifted ASHP energy demand indicated that there was a substantial cost penalty associated with running the heat pump during off peak periods, due primarily to the increased energy requirements.

Finally, simulation of a population of 50 buffered heat pumps indicated that constraining them to

operate only in off peak periods had the potential to substantially increase the peak electrical demand seen on the network compared to the case when the heat pumps were unbuffered and their operation was unconstrained. In the case shown, demand doubled, with the peak demand moving to off-peak periods.

To reduce the potential impact of heat pumps on the network will require algorithms and systems for careful orchestration of individual heat pumps in addition to thermal buffering.

NOMENCLATURE

Symbols

c – carbon intensity (kg/MW or g/kW)

n – number of generation sources

P – power MW

t – time

Δt – time interval (hours)

Subscripts

ave – average

x – relating to a specific generation source

Acronyms

ASHP – air source heat pump

COP – coefficient of performance

DHW – domestic hot water

GBP – Great Britain pounds

PCM – phase change material

ACKNOWLEDGMENTS

The simulation work described in this article was done within the SUPERGEN Highly Distributed Energy Futures research consortium (HIDEF). The authors gratefully acknowledge the funding and support provided by the UK Research Council's Energy Programme under grant EP/G031681/1. The authors also wish to acknowledge the assistance of members of IEA ECBCS Annex 54 for their help and useful input to this work.

REFERENCES

- Beyer D and Kelly N J, 2008. Modelling the Behaviour of Domestic Micro-Cogeneration under Different Operating Regimes and with Variable Thermal Buffering, Proc. Microgen, National Arts Centre, Ottawa.
- Clarke J A, Johnstone C M, Kim J M and Tuohy P G 2008. Energy, Carbon and Cost Performance of Building Stocks: Upgrade Analysis, Energy Labelling and National Policy Development, Advances in Building Energy Research 3, Earthscan, London.
- ESP-r, 2013. www.strath.ac.uk/Programs/ESP-r.htm Accessed 14.02.13.
- Economy10, 2012. <http://www.electricityprices.org.uk/economy-10>. Accessed 1.11.2012.

- Elexion, 2012. www.elexon.co.uk. Accessed 10.12.2012.
- Hewitt, N J “Heat pumps and energy storage – the challenges of implementation”, *Applied Energy*, 89, pp37-44 2012.
- Hawkes A. D., 2010. Estimating marginal CO2 emissions rates for national electricity systems, *Energy Policy*, 10(38), pp5977–5987.
- Hong J, Kelly N J, Thomson M, Richardson I (2013) Assessing heat pumps as flexible load, *Proceedings of the IMECHE Part A: Journal of Power and Energy*, 227(1), pp30-42.
- Johnston D, Wingfield J, Bell M, 2012. Airtightness of buildings–towards higher performance. Interim report D1 Available online: Centre for the built Environment, Leeds Metropolitan University. <http://www.lmu.ac.uk/as/cebe/projects/airtight/airtight1.pdf>. Accessed 26.08.2012.
- Jordan U and Vajen K, 2005. DHWCALC: Program to Generate Domestic Hot Water Draws with Statistical Means for User Defined Conditions, *Proc. ISES Solar World Congress, Orlando, US*.
- Kelly N J and Cockroft J, 2012. Analysis of retrofit air source heat pump performance : Results from detailed simulations and comparison to field trial data. *Energy and Buildings*, 43 (1). pp239-245.
- Knight I, Ribberink H (eds.), 2007. European and Canadian non-HVAC Electric and DHW Load Profiles for Use in Simulating the Performance of Residential Cogeneration Systems, A Report of Subtask A of FC+COGEN-SIM The Simulation of Building-Integrated Fuel Cell and Other Cogeneration Systems, Annex 42 of the International Energy Agency Energy Conservation in Buildings and Community Systems Programme. Natural Resources Canada, Ottawa, 2007.
- Moreau, A. 2011. Control Strategy for Domestic Water Heaters during Peak Periods and its Impact on the Demand for Electricity. *Energy Procedia* vol. 12 pp1074-1082
- National Grid 2012. <http://www.nationalgrid.com/uk/Electricity/Data/Demand+Data/> Jan-July Accessed 22.11.2012.
- Palmer J, Cooper I (eds.), 2011. Great Britain’s Housing Energy Fact File, Department for Energy and Climate Change Publication URN 11D/866.
- Padovan R and Manzan M, 2013. Development of a stratified tank storage component for ESP-r with embedded phase change material modules, *Proceedings of the IMECHE Part A: Journal of Power and Energy*, 227(1) pp53-61.
- PCM Products, 2012. http://www.pcmproducts.net/Phase_Change_Material_Products.htm. Accessed 30.10.2012.
- Shipworth, M., Firth, S. K. , Gentry, M. I., Wright, A. J., Shipworth, D. T. and Lomas, K. J., 2010. Central heating thermostat settings and timing: building demographics, *Building Research & Information*, 38(1), 50-69. Central heating thermostat settings and timing: Building demographics
- Thomson M, Infield D, 2007. Impact of widespread photovoltaics generation on distribution systems, *Journal of Renewable Power Generation*, Vol 1 (1), pp33-40.

Table 4 Performance of buffered load shifted and unbuffered unconstrained heat pumps over a cool winter week.

	Unbuffered	Sensible 1200 l	PCM-enhanced 500 l 50% PCM
Average living room temperature (°C)	21.05	21.31	20.98
Average rest-of-house temperature (°C)	17.53	18.96	18.57
Average buffer temperature (°C)	n/a	45.57	45.82
Average DHW temp (°C)	44.19	43.53	43.16
Average ASHP COP (-)	3.08	2.61	2.61
ASHP heat output (kWh)	218.17	293.05	255.45
ASHP electrical energy (kWh)	73.03	114.39	99.96
ASHP cycles -	164	106	131
Low living room temperature (%)	0.00	0.00	0.24
Low DHW temperature (%)	2.62	2.99	3.50
CO ₂ (kg)	37.84	59.62	51.84
ASHP running cost (£ GBP)	9.55	12.05	10.53

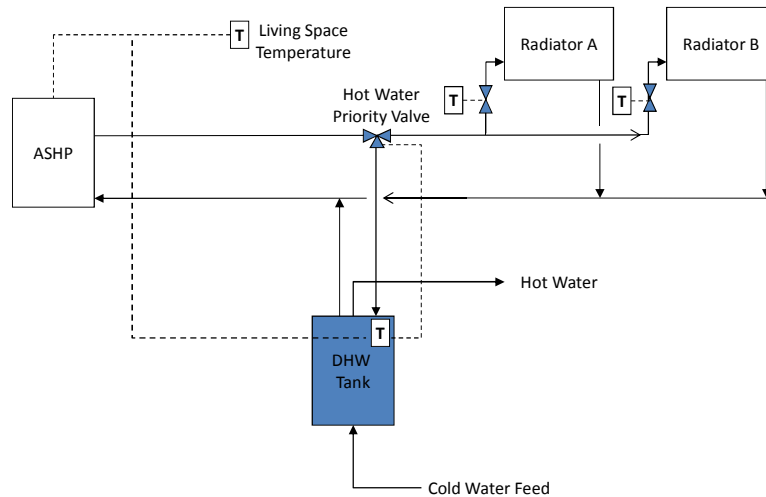

Figure 1 The modelled heating system supplied by the ASHP (with no buffer tank).

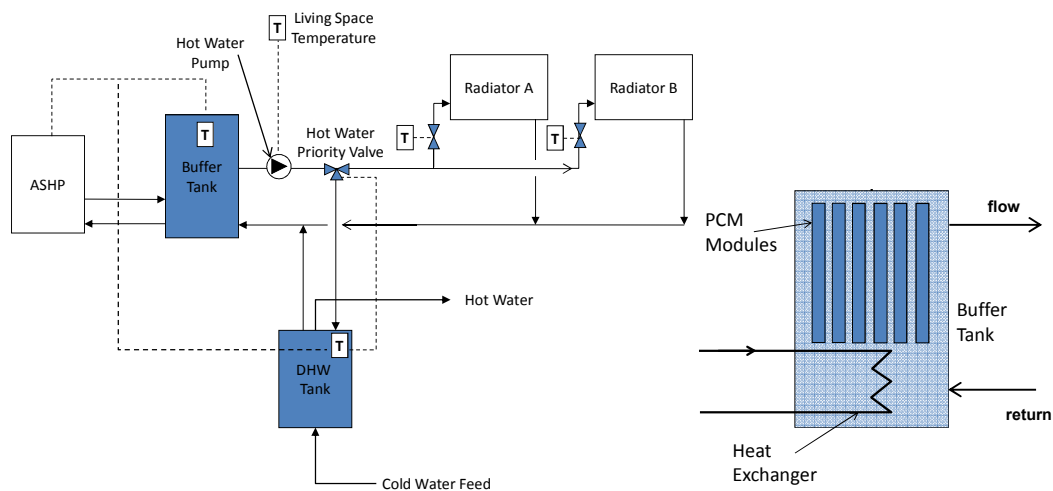

Figure 2 The modelled heating system supplied by the ASHP (with PCM-enhanced buffer tank).

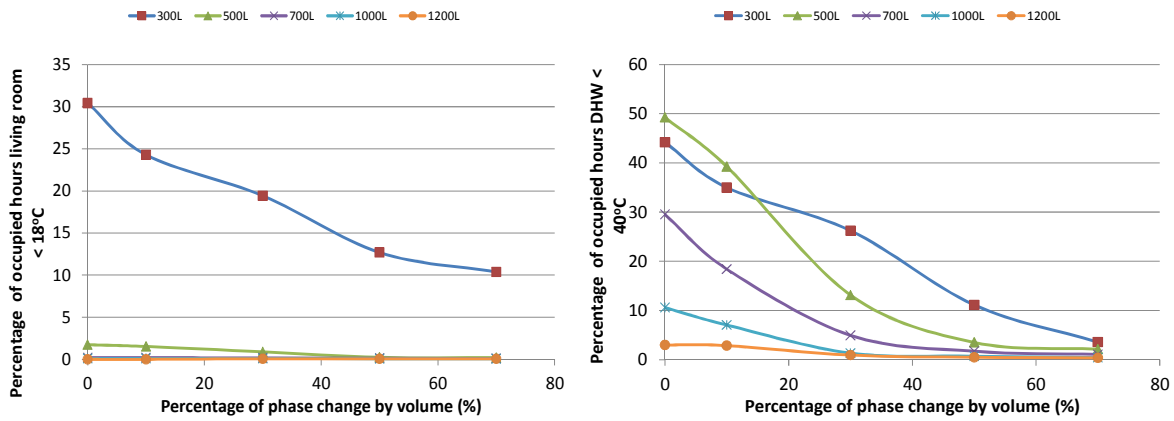

Figure 3 The effect of PCM on the occurrence of low space and hot water temperatures over a cool winter week.

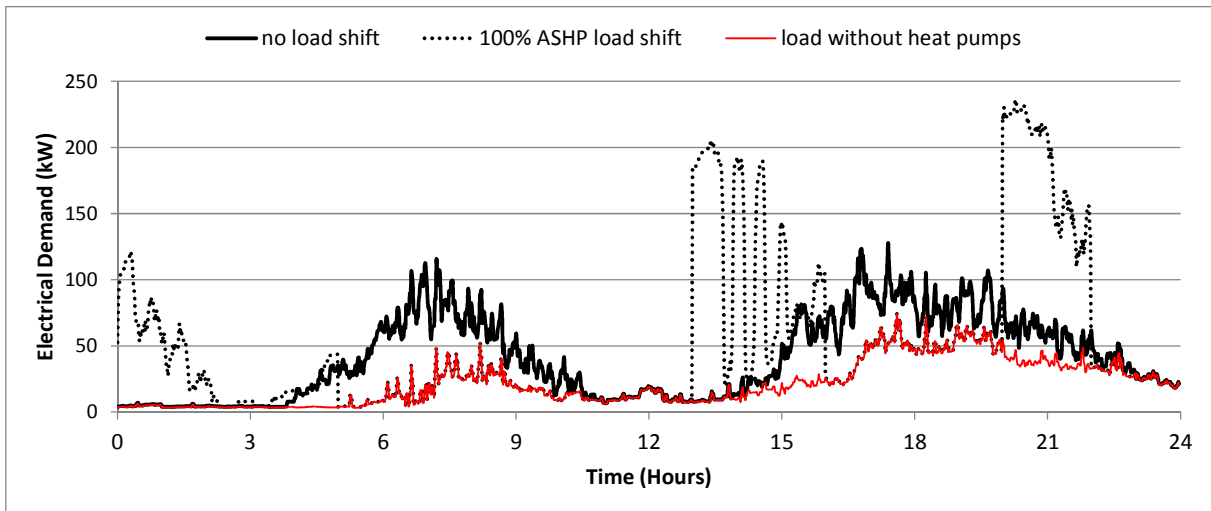

Figure 4 effect of load shifting 100% of heat pumps on the aggregate demand of 50 dwellings on a winter day.

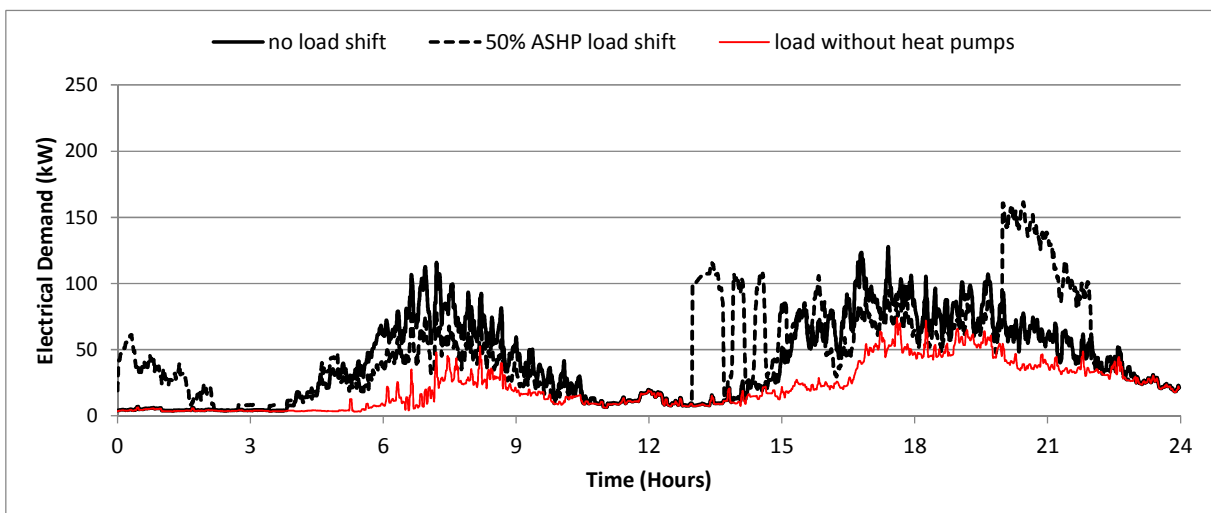

Figure 5 effect of load shifting 50% of heat pumps on the aggregate demand of 50 dwellings on a winter day.