

The London School of Economics and Political Science

**OPTIMAL STOPPING PROBLEMS
IN MATHEMATICAL FINANCE**

by

Neofytos Rodosthenous

*A thesis submitted to the Department of Mathematics of
the London School of Economics and Political Science
for the degree of
Doctor of Philosophy
London, May 2013*

Supported by the London School of Economics and
the Alexander S. Onassis Public Benefit Foundation



Declaration

I certify that the thesis I have presented for examination for the MPhil/PhD degree of the London School of Economics and Political Science is solely my own work other than where I have clearly indicated that it is the work of others (in which case the extent of any work carried out jointly by me and any other person is clearly identified in it).

The copyright of this thesis rests with the author. Quotation from it is permitted, provided that full acknowledgement is made. This thesis may not be reproduced without my prior written consent.

I warrant that this authorisation does not, to the best of my belief, infringe the rights of any third party.

I declare that my thesis consists of 110 pages (including bibliography).

Abstract

This thesis is concerned with the pricing of American-type contingent claims.

First, the explicit solutions to the perpetual American compound option pricing problems in the Black-Merton-Scholes model for financial markets are presented. Compound options are financial contracts which give their holders the right (but not the obligation) to buy or sell some other options at certain times in the future by the strike prices given. The method of proof is based on the reduction of the initial two-step optimal stopping problems for the underlying geometric Brownian motion to appropriate sequences of ordinary one-step problems. The latter are solved through their associated one-sided free-boundary problems and the subsequent martingale verification for ordinary differential operators. The closed form solution to the perpetual American chooser option pricing problem is also obtained, by means of the analysis of the equivalent two-sided free-boundary problem.

Second, an extension of the Black-Merton-Scholes model with piecewise-constant dividend and volatility rates is considered. The optimal stopping problems related to the pricing of the perpetual American standard put and call options are solved in closed form. The method of proof is based on the reduction of the initial optimal stopping problems to the associated free-boundary problems and the subsequent martingale verification using a local time-space formula. As a result, the explicit algorithms determining the constant hitting thresholds for the underlying asset price process, which provide the optimal exercise boundaries for the options, are presented.

Third, the optimal stopping games associated with perpetual convertible bonds in an extension of the Black-Merton-Scholes model with random dividends under different information flows are studied. In this type of contracts, the writers have a right to withdraw the bonds before the holders can exercise them, by converting the bonds into assets. The value functions and the stopping boundaries' expressions are derived in closed-form in the case of observable dividend rate policy, which is modelled by a continuous-time Markov chain. The analysis of the associated parabolic-type free-boundary problem, in the case of unobservable dividend rate policy, is also presented and the optimal exercise times are proved to be the first times at which the asset price process hits boundaries depending on the running state of the filtering dividend rate estimate. Moreover, the explicit estimates for the value function and the optimal exercise boundaries, in the case in which the dividend rate is observable by the writers but unobservable by the holders of the bonds, are presented.

Finally, the optimal stopping problems related to the pricing of perpetual American options in an extension of the Black-Merton-Scholes model, in which the dividend and volatility rates of the underlying risky asset depend on the running values of its maximum and its maximum drawdown, are studied. The latter process represents the difference between the running max-

imum and the current asset value. The optimal stopping times for exercising are shown to be the first times, at which the price of the underlying asset exits some regions restricted by certain boundaries depending on the running values of the associated maximum and maximum drawdown processes. The closed-form solutions to the equivalent free-boundary problems for the value functions are obtained with smooth fit at the optimal stopping boundaries and normal reflection at the edges of the state space of the resulting three-dimensional Markov process. The optimal exercise boundaries of the perpetual American call, put and strangle options are obtained as solutions of arithmetic equations and first-order nonlinear ordinary differential equations.

Contents

Introduction	5
I. Description of the subject	5
II. Historical notes and references	6
III. Contribution of the thesis	11
IV. Summary of the thesis	13
V. Acknowledgements	14
1. On the pricing of perpetual American compound options	16
1.1. Preliminaries	16
1.2. Solutions of the free-boundary problems	20
1.3. Main results and proofs	25
1.4. Chooser options	29
2. Perpetual American options in a diffusion model with piecewise-linear coefficients	36
2.1. Preliminaries	36
2.2. Solutions of the free-boundary problem	38
2.3. Main results and proof	49
3. Optimal stopping games in models with different information flows	53
3.1. Preliminaries	53
3.2. The case of full information	59
3.3. The case of partial information	74
3.4. The case of asymmetric information	80
4. Optimal stopping problems in diffusion-type models with running maxima and drawdowns	82
4.1. Preliminaries	82
4.2. Solution of the free-boundary problem	86
4.3. Main results and proof	97
Bibliography	102

Introduction

I. Description of the subject

The focus of this thesis is *optimal stopping problems*, which is an important and well-developed class of stochastic control problems. In such problems, we aim to find stopping times, at which the underlying stochastic processes should be stopped in order to optimise the values of some given functionals (e.g. maximise gain functions, minimise loss functions, etc). These kind of problems appear in various different research areas in sciences, one of which is *mathematical finance*. A great deal of the *derivatives* traded in the financial markets all over the world is of the so-called *American-type*. Contrary to the European-type derivatives, the holders of which have the opportunity to exercise only at a fixed maturity time, the American-type derivatives can be exercised at any time up to maturity. The rational (no-arbitrage) prices of such contracts are given by the values of their associated optimal stopping problems, which are considered under some martingale measures for the underlying risky asset price processes. A broad overview of the general theory, explanations of the main concepts and results, examples and proofs of key facts as well as the principles of the methods used for solving optimal stopping problems in various stochastic models can be found in [97], [105; Chapter VIII], [70] and [44].

A formulation of the general optimal stopping problem for sequences of random variables and the establishment of the *supermartingale characterization* of its value function was presented by Snell [107]. Then, it was observed by Dynkin [31] that the proposed in [107] supermartingale characterization of the value function of an optimal stopping problem is *superharmonic*, whenever the underlying sequence of random variables is *Markovian*. This resulted to further development of the field by allowing for more concrete results.

The optimal stopping times in the problems involving *continuous time* Markov processes were proved to be the first exit times of the associated Markov processes called *sufficient statistics* from some continuation regions specified by optimal stopping boundaries. The crucial connection between optimal stopping problems for continuous Markov processes and *free-boundary problems* for *differential operators* (see also e.g., Stefan's ice-melting problem in *mathematical physics*) was discovered (see also [58] for a result in a general multi-dimensional case). A detailed analysis of optimal stopping problems for continuous time Markov processes can be found in the book of Peskir and Shiryaev [97]. Based on these results the optimal values of

given functionals in continuous Markov models can be obtained in analytic expressions. The closed-form solutions of these free-boundary problems satisfying *certain additional conditions* are then proved to be the solutions of the initial optimal stopping problems, through some standard verification arguments from stochastic analysis. These include the application of the relevant change-of-variable formula (i.e. Itô's formula or its various extensions) and Doob's optional sampling theorem. A complete overview of the optimal stopping theory for both discrete- and continuous-time Markov processes can be found in the monograph of Shiryaev [104].

In order to select the unique solution of the free-boundary problem, which will eventually turn out to be the solution of the initial optimal stopping problem, the specification of these *additional conditions* in the free-boundary problems becomes essential. It was observed and then proved by many different authors, that if the underlying process exits the continuation region continuously, then the smooth-fit condition for the value function at the optimal stopping boundary should hold. Different proofs of the *principle of smooth fit* in continuous Markov models are contained in [104; Chapter III] and [97; Chapter IV]) (see also [58] for sufficient conditions for the occurrence of smooth fit in a general multi-dimensional continuous Markov model).

The value function, obtained as a solution of optimal stopping problems involving the running maximum process of continuous Markov (diffusion) processes, satisfies the *normal-reflection condition* on the diagonal of the state space of the two-dimensional process, whose components are given by the underlying and its running maximum. This fact was proved by Dubins, Shepp and Shiryaev [28] through the solution of the optimal stopping problem, which appeared in the proof of the related maximal inequalities for Bessel processes on random time intervals in stochastic calculus. A key result in the general theory, which proved that the *maximality principle* is equivalent to the superharmonic characterization of the value function, was established by Peskir [90], through the solution of the same problem in a general diffusion model (see also [64], [56]-[57]).

II. Historical notes and references

Let us now present some historical notes on the optimal stopping problems studied in this thesis and refer to the relevant literature, by also specifying the position of the results of this thesis.

Compound options are financial contracts which give their holders the right (but not the obligation) to buy or sell some other options at certain times in the future by the strike prices given. Such contingent claims are widely used in currency, stock, and fixed income markets, for the sake of risk protection (see, e.g. Geske [52]-[54] and Hodges and Selby [63] for the first financial applications of compound options of European type). In the real financial world, a

common application of such contracts is the hedging of bids for business opportunities which may or may not be accepted in the future, and which become available only after the previous ones are undertaken. This fact makes compound options an important example of using real options to undertake business decisions which can be expressed in the presented perspective (see Dixit and Pindyck [27] for an extensive introduction). Other important modifications of such contracts are compound contingent claims of *American type* in which both the initial and underlying options can be exercised at any (random) times up to maturity. The rational (no-arbitrage) pricing problems for such contracts are considered in [48] (Chapter 1), where they are embedded into *two-step optimal stopping problems* for the underlying asset price processes. The latter are decomposed into appropriate sequences of ordinary one-step optimal stopping problems which are then solved sequentially.

Apart from the extensive literature on optimal switching as well as impulse and singular stochastic control, the *multi-step optimal stopping problems* for underlying one-dimensional diffusion processes have recently drawn a considerable attention. Duckworth and Zervos [29] studied an investment model with entry and exit decisions alongside a choice of the production rate for a single commodity. The initial valuation problem was reduced to a two-step optimal stopping problem which was solved through its associated dynamic programming differential equation. Carmona and Touzi [19] derived a constructive solution to the problem of pricing of perpetual swing contracts, the recall components of which could be viewed as contingent claims with multiple exercises of American type, using the connection between optimal stopping problems and their associated Snell envelopes. Carmona and Dayanik [18] then obtained a closed form solution of a multi-step optimal stopping problem for a general linear regular diffusion process and a general payoff function. Algorithmic constructions of the related exercise boundaries were also proposed and illustrated with several examples of such optimal stopping problems for several linear and mean-reverting diffusions. Other infinite horizon optimal stopping problems with finite sequences of stopping times are being sought. Some of them are related to hiring and firing options and were recently considered by Egami and Xu [33] among others.

The problems related to the option pricing theory in mathematical finance and insurance, where the underlying process can describe the price of a risky asset (e.g. the value of a company) on a financial market have become of great importance. Such *perpetual option pricing problems* were first studied by McKean [81], who proved the optimality of the first time at which the price of the underlying risky asset, modelled by a geometric Brownian motion, hits a constant threshold (see also Shiryaev [105; Chapter VIII; Section 2a], Peskir and Shiryaev [97; Chapter VII; Section 25], and Detemple [26] for an extensive overview of other related results in the area). Note that the obtained prices of perpetual American options can be considered as upper bounds for the values of the corresponding European options with finite expiry, which are widely used by practitioners. Mordecki [83]-[84], Asmussen, Avram and Pistorius [5], and

Alili and Kyprianou [4] proved the optimality of the threshold strategies for the underlying process and derived closed form expressions for the values of these optimal stopping problems in several exponential Lévy models. Some associated optimal stopping games for such processes were recently studied by Baurdoux and Kyprianou [9] among others.

The framework of the so-called *local models of stochastic volatility*, in which the diffusion coefficients depend on both the time and the current state of the underlying risky asset price process, was proposed by Dupire [30] and Derman and Kani [25]. Apart from easy calibration features (see, e.g. [30] and [25]), such extensions of the classical model with constant coefficients remained within complete market setting in which any contingent claim can be replicated by an admissible self-financing portfolio strategy, based on the underlying asset and the riskless bank account only. More recently, Ekström [34]-[35] found explicit values for the rational prices of the perpetual American options and investigated their properties in some diffusion models with time- and state-dependent volatility coefficients. The call-put duality for perpetual American options was studied by Alfonsi and Jourdain [2]-[3] within a local volatility and constant dividend yield framework. Villeneuve [109] proposed a model with both the volatility and dividend yield coefficients depending on the underlying price process and investigated sufficient conditions on the payoff functions ensuring the optimality of the constant threshold exercise strategies for the perpetual American options. The closed-form solutions to the perpetual American put and call options in a diffusion model with piecewise-constant dividend and volatility coefficients are presented in [49] (Chapter 2). Using a geometric approach, Lu [80] presented a solution of the optimal stopping problem related to the perpetual American put option in a dividend-free model with piecewise-constant volatility rate. He also studied the inverse problem of recovering the volatility rate of such type from the perpetual put option prices, initiated by Ekström and Hobson [36] within the general local volatility framework.

Optimal stopping problems for general time-homogeneous one-dimensional diffusion processes were studied in Salminen [101] and Beibel and Lerche [13] for the cases of deterministic and random discounting, respectively. Dayanik and Karatzas [24] provided a characterization of the value functions of the optimal stopping problems for such general diffusions as the smallest nonnegative concave majorants of the reward functions. Rüschemdorf and Urusov [100] used the free-boundary approach to study optimal stopping problems for integral functionals of general one-dimensional diffusion processes, the coefficients of which do not satisfy the usual regularity assumptions. More recently, Christensen and Irle [21] characterized stopping regions of optimal stopping problems in terms of harmonic functions for general one-dimensional diffusions.

Stochastic game-theoretic problems in which both participants can select random (stopping) times, at which certain payoffs should be made from one participant to the other, attracted a considerable attention in the literature on optimal stochastic control. The study of such game-theoretic problems was initiated by Dynkin [32]. The purely probabilistic approach for the

analysis of such games, based on the application of martingale theory, was developed in Neveu [85], Krylov [74], Bismut [17], Stettner [108], and Lepeltier and Mainguenu [78] among others. The analytical theory of stochastic differential games with stopping times was developed in Bensoussan and Friedman [14]-[15] in Markov diffusion models. The latter approach, dealing with the analysis of the value functions and saddle points of such games, was based on the usage of the theory of variational inequalities and free-boundary problems for partial differential equations. Cvitanic and Karatzas [22] established a connection between the values of optimal stopping games and the solutions of backward stochastic differential equations with reflection and provided a pathwise approach to these games. Karatzas and Wang [71] studied such games in a more general non-Markovian setting and brought them into connection with bounded-variation optimal control problems. More recently, Ekström and Peskir [37] and Peskir [93]-[95] proved that the value function of a general optimal stopping game for a right-continuous strong Markov process is measurable and found necessary and sufficient conditions for the existence of the Stackelberg and Nash equilibria. Bayraktar and Sirbu [12] applied stochastic Perron's method and verification without smoothness using viscosity comparison for solving obstacle problems and Dynkin games.

The related concept of the so-called *game-type* (or *Israeli*) *contingent claims* for models of financial markets was introduced by Kifer [73], who generalised the one of American-type claims, by also allowing the writer to cancel the contract prematurely at the expense of some penalty. It was shown that the problem of pricing and hedging of such options can be reduced to solving an associated optimal stopping game. Kyprianou [77] obtained explicit expressions for the value functions of two classes of perpetual game option problems. Kühn and Kyprianou [76] characterized the value functions of the finite expiry versions of these classes of options via mixtures of other exotic options using martingale arguments and then produced the same analysis for a more general class of finite expiry game options via a pathwise pricing formulae. Kallsen and Kühn [67]-[68] applied the neutral valuation approach to American and game options in incomplete markets and introduced a mathematically rigorous dynamic concept to define no-arbitrage prices for game contingent claims. Sirbu, Pikovsky and Shreve [106] studied the convertible bond optimal stopping game within a structural model for the underlying risky asset. Further calculations of rational prices of perpetual game options and convertible bonds in reduced form models involving jump-diffusion structure were provided by Baurdoux and Kyprianou [8]-[10], Ekström and Villeneuve [38], and Baurdoux, Kyprianou and Pardo [11] among others, and involving random-dividend structure, modelled by a continuous Markov chain (under different information flows), are provided in Chapter 3.

Several versions of such models in which the drift and volatility coefficients of the underlying asset price process switch their values, according to the change in the state of continuous Markov chains, have been considered in the option pricing theory. The closed-form solutions of the

perpetual American lookback and put option pricing problems were obtained by Guo [59] and Guo and Zhang [62] in a version of such a model in which the drift and volatility coefficients of the underlying asset price process are switching between two constant values, according to the change in the state of the observable continuous-time Markov chain. Jobert and Rogers [66] considered the perpetual American put option problem within an extension of that model to the case of several states for the Markov chain and solved the corresponding problem with finite expiry numerically. In the model with a two-state Markov chain and no diffusion part, Dalang and Hongler [23] presented a complete and essentially explicit solution to a similar problem, which exhibited a surprisingly rich structure. These results were further extended by Jiang and Pistorius [65], who studied the perpetual American put option problem within the framework of an exponential jump-diffusion model with observable dynamics of regime-switching behaving parameters.

Optimal stopping problems for *running maxima* of some diffusion processes given linear costs were studied by Jacka [64], Dubins, Shepp, and Shiryaev [28], and Graversen and Peskir [56]-[57] among others, with the aim of determining the best constants in the corresponding maximal inequalities. A complete solution of a general version of the same problem was obtained in Peskir [90], by means of the established maximality principle which is equivalent to the superharmonic characterization of the value function. Discounted optimal stopping problems for certain payoff functions depending on the running maxima of geometric Brownian motions were initiated by Shepp and Shiryaev [102]-[103] and then considered by Pedersen [89] and Guo and Shepp [60] among others, with the aim of computing rational values of perpetual American lookback (Russian) options. More recently, Guo and Zervos [61] derived solutions for discounted optimal stopping problems related to the pricing of perpetual American options with certain payoff functions depending on the running values of both the initial diffusion process and its associated maximum. Glover, Hulley, and Peskir [55] provided solutions of optimal stopping problems for integrals of functions depending on the running values of both the initial diffusion process and its associated minimum. The main feature of the resulting optimal stopping problems is that the normal-reflection condition holds for the value function at the diagonal of the state space of the two-dimensional continuous Markov process having the initial process and its running extremum as the components, which implies the characterization of the optimal boundaries as extremal solutions of one-dimensional first-order nonlinear ordinary differential equations.

Asmussen, Avram, and Pistorius [5] considered perpetual American options with payoffs depending on the running maximum of some Lévy processes with two-sided jumps having phase-type distributions in both directions. Avram, Kyprianou, and Pistorius [6] studied exit problems for spectrally negative Lévy processes and applied the results to solving optimal stopping problems for payoff functions depending on the running values of the initial processes or their associated maxima. Optimal stopping games with payoff functions of such type were

considered by Baurdoux and Kyprianou [10] within the framework of models based on spectrally negative Lévy processes. Other complicated optimal stopping problems for the running maxima were considered by Gapeev [43] for a jump-diffusion model with compound Poisson processes with exponentially distributed jumps and by Ott [87] (see also [88]) for a model based on spectrally negative Lévy processes. More recently, Peskir [94]-[96] studied optimal stopping problems for three-dimensional Markov processes having the initial diffusion process as well as its maximum and minimum as the state space components. It was shown that the optimal boundary surfaces depending on the maximum and minimum of the initial process provide the maximal and minimal solutions of the associated systems of first-order non-linear partial differential equations. The perpetual American strangle options pricing problems in a diffusion-type extension of the Black-Merton-Scholes model, for which the dividend and the volatility coefficients depend on both the running maximum and maximum drawdown processes of the underlying, are studied in Chapter 4. The *drawdown process* represents the difference between the running values of the underlying asset price and its maximum and can therefore be interpreted as the market depth. The Laplace transforms of the drawdown process and other related characteristics associated with certain classes of the initial processes such as diffusion models (including constantly drifted Brownian motions, the Ornstein-Uhlenbeck process and the Cox-Ingersoll-Ross model), and spectrally positive and negative Lévy processes were studied by Pospisil, Vecer, and Hadjilidiadis [98] and by Mijatovic and Pistorius [82], respectively.

III. Contribution of the thesis

Let us now summarise the contribution of the thesis into the methods of optimal stopping problems and their applications.

The explicit solutions to the problems of pricing of the perpetual American standard compound options in the Black-Merton-Scholes model are derived (Chapter 1 or [48]), something which has not been done so far. For this, the approach based on the reduction of the resulting optimal stopping problems to their associated one-sided ordinary differential free-boundary problems, described profoundly in the monograph of Peskir and Shiryaev [97] (see also Dayanik and Karatzas [24]), is followed. It turns out that the payoff functions of some compound options are concave and the resulting value functions may have different structure, depending on the relations between the strike prices given. Moreover, a closed form solution to the problem of pricing of the perpetual American chooser option is obtained through its associated two-sided ordinary differential free-boundary problem. It is shown that the admissible intervals for the resulting exercise boundaries are smaller than the ones of the related strangle option recently studied by Gapeev and Lerche [47]. Note that the problem of pricing of American compound options was recently studied by Chiarella and Kang [20] in a more general stochastic volatility

framework. The associated two-step free-boundary problems for partial differential equations were solved numerically, by means of a modified sparse grid approach.

The rational prices of the perpetual American standard put and call options in an extension of the Black-Merton-Scholes model for underlying dividend paying assets with both piecewise-constant dividend and volatility rates are presented (Chapter 2 or [49]). It is assumed that these rates change their values at the times at which the underlying asset price process crosses some prescribed constant levels under the risk-neutral probability measure. Such a situation may appear in the case in which either the firm issuing the asset decides to change the dividend rate paid to stockholders or the volatility rate of the asset changes from one value to another at the times at which the market price crosses certain levels. These levels can have both statistical and psychological nature depending on the strategies of market participants. This model represents another example of local models of stochastic dividend and volatility, in which the related coefficients depend on the current state of the underlying asset price process and provides an approximation of the corresponding diffusion models with continuous coefficients studied in [34]-[35], [2]-[3], and [109]. A linear version of this diffusion model was proposed by Radner and Shepp [99] with the aim of solving some stochastic optimal impulse control problems. Explicit algorithms to determine the constant hitting thresholds for the underlying diffusion process, which provide the optimal exercise boundaries for the options, are presented. Based on solving the associated free-boundary problems, our approach should allow to handle optimal stopping problems with more complicated payoffs than the ones of put and call options, within the general diffusion framework of both piecewise-linear drift and diffusion coefficients.

The perpetual convertible bond pricing problem is studied in an extension of the Black-Merton-Scholes model in which the dynamics of the dividend rate of the underlying risky asset are described by means of a two-state continuous-time Markov chain (Chapter 3). Closed-form solutions to the associated optimal stopping games for the case in which the Markov chain is observable by both the writer and the holder of the convertible bond (full information) are derived. An analysis of the equivalent parabolic-type free-boundary problem for the case in which the Markov chain is unobservable by both participants of the contract (partial information) is also presented, as well as the case in which the Markov chain is observable by the writer but remains unobservable by the holder of the bond (asymmetric information) is studied.

The perpetual American standard options pricing problem in an extension of the Black-Merton-Scholes model with path-dependent coefficients is studied and closed-form solutions are obtained (Chapter 4). The underlying asset price dynamics are described by a geometric diffusion-type process X with local drift and diffusion coefficients which essentially depend on the running values of the maximum process S and the maximum drawdown process Y , defined in (4.1.1)-(4.1.3). It is shown that the optimal exercise times are the first times at which the process X exits some regions restricted by certain boundaries depending on the running

values of S and Y . The process Y represents the maximum of the difference between the running values of the underlying asset price and its maximum and can therefore be interpreted as the maximum of the market depth. Closed-form expressions for the value function of the resulting free-boundary problem are derived and the maximality principle from [90] is applied to describe the optimal boundary surfaces as the extremal solutions of first-order nonlinear ordinary differential equations. The starting points for these surfaces at the edges of the three-dimensional state space are specified from the solutions of the corresponding optimal stopping problem for the two-dimensional Markov process (X, S) in a model in which the coefficients of the process X depend only on the running maximum process S .

IV. Structure of the thesis

In Section 1.1, we formulate the perpetual American compound option problems and then specify the decompositions of the initial two-step optimal stopping problems into sequences of ordinary one-step problems for the underlying geometric Brownian motion. In Section 1.2, we derive explicit solutions of the four resulting one-sided ordinary differential free-boundary problems. In Section 1.3, we verify that the solution of the free-boundary problem related to the most informative put-on-call case provides the solution of the initial two-step optimal stopping problem. In Section 1.4, we present a closed form solution to the two-sided free-boundary problem associated with the perpetual American chooser option. The main results of Chapter 1 are stated in Propositions 1.3.1-1.3.4 and 1.4.1.

In Section 2.1, we formulate the perpetual American put and call option pricing optimal stopping problems in a diffusion model with piecewise-linear coefficients and their associated ordinary differential free-boundary problems. In Section 2.2, we derive solutions to the resulting systems of arithmetic equations equivalent to the free-boundary problems for the put and call options, separately. In Section 2.3, we verify that the solutions of the free-boundary problems provide the solutions of the initial optimal stopping problems. The main result of Chapter 2 is stated in Theorem 2.3.1.

In Section 3.1, we formulate the associated optimal stopping game for a two-dimensional Markov diffusion process, which has the underlying risky asset price and the filtering dividend rate estimate as its state space components. We show that the optimal exercise time of the writer and the holder of the convertible bond is expressed as the first time at which the asset price process hits stochastic boundaries depending on the running state of the filtering dividend rate estimate. In Section 3.2, we derive closed-form solutions of the coupled ordinary free-boundary problem, associated with the optimal stopping game for the case in which the continuous-time Markov chain, expressing the dividend policy, is observable by both participants of the contract. In Section 3.3, we provide an analysis of the parabolic-type free-boundary

problem equivalent to the optimal stopping game in the case of an unobservable Markov chain. Applying the change-of-variable formula with local time on surfaces from Peskir [92], we verify that the appropriate (unique) solution of the free-boundary problem gives the solution to the initial optimal stopping game. We also obtain a closed-form solution of the free-boundary problem under certain relations between the parameters of the model. In Section 3.4, we propose a solution to the optimal stopping game for the case in which the Markov chain is observable by the writer but remains unobservable by the holder of the bond. The main results of Chapter 3 are stated in Theorems 3.2.1 and 3.3.1, and Corollary 3.4.1.

In Section 4.1, we formulate the associated optimal stopping problem for a necessarily three-dimensional continuous Markov process which has the underlying asset price and the running values of its maximum and maximum drawdown as the state space components. The resulting optimal stopping problem is reduced to its equivalent free-boundary problem for the value function which satisfies the smooth-fit conditions at the stopping boundaries and the normal-reflection conditions at the edges of the state space of the three-dimensional process. In Section 4.2, we obtain closed-form solutions of the associated free-boundary problem in which the sought boundaries are found as unique solutions of appropriate systems of arithmetic equations or first-order nonlinear ordinary differential equations, where we specify the starting values for the latter on the edges of the three-dimensional state space. In Section 4.3, we verify by applying the change-of-variable formula with local time on surfaces, that the resulting solutions of the free-boundary problem provide the expressions for the value function and the optimal stopping boundaries for the underlying asset price process in the initial problem. The main results of Chapter 4 are stated in Propositions 4.3.1-4.3.3.

V. Acknowledgements

I would like to express my gratitude and appreciation to Mihail Zervos and Pavel V. Gapeev for the endless hours they invested, not only to enhance my mathematical knowledge, particularly in stochastic control theory, but also to help me develop my own way of thinking. I am grateful they played such an important role in the fulfillment of this thesis and for setting the example of an intellectual, which has been most influential.

I gratefully acknowledge the support from the Alexander Onassis Public Benefit Foundation in Greece and their contribution to the realisation of this thesis by awarding me the scholarship for my doctoral studies.

The Mathematics Department of the London School of Economics and Political Science has been an excellent academic environment for conducting research and a place full of intelligent people. I would like to thank Albina Danilova and Arne Lokka for their interest and useful comments, and Dave Scott for his continuous administrative support. I feel fortunate for having

as a fellow PhD student, my friend Filippo Riccardi, with whom we studied for countless hours trying to understand several aspects of stochastic calculus.

During my studies, I have been fortunate to meet Ioannis Karatzas and Jean-Pierre Zigrand and I cannot thank them enough for showing me what it is like to be a truly inspirational and impactful teacher. I would also like to thank all the influential teachers I have had previously in my life, who contributed in the formation of my scientific thought. Especially, Haralambos Papageorgiou, whose continuous support and guidance has been vital.

I thank Hongzhong Zhang for his hospitality during my stay at the Columbia University and together with Olympia Hadjiliadis for our many fruitful discussions.

Finally and most importantly, there are no words to describe how grateful I am to my parents Christos and Andri, my sister Popi and my grandparents Takis, Artemis and Popi, for believing in me and supporting me in every step of the way. Last but not least, my friends from Cyprus and Greece, who have constantly been by my side, will always have a special place in my heart. The encouragement of all these people made this thesis possible.

Chapter 1

On the pricing of perpetual American compound options

In this chapter (following [48]), we present explicit solutions to the perpetual American compound option pricing problems in the Black-Merton-Scholes model. The method of proof is based on the reduction of the initial two-step optimal stopping problems for the underlying geometric Brownian motion to appropriate sequences of ordinary one-step problems. The latter are solved through their associated one-sided free-boundary problems and the subsequent martingale verification. We also obtain a closed form solution to the perpetual American chooser option pricing problem, by means of the analysis of the equivalent two-sided free-boundary problem.

1.1. Preliminaries

In this section, we give a formulation of the perpetual American compound option optimal stopping problems and the associated ordinary differential free-boundary problems.

1.1.1. Formulation of the problem. For a precise formulation of the problem, let us consider a probability space (Ω, \mathcal{F}, P) carrying a standard one-dimensional Brownian motion $B = (B_t)_{t \geq 0}$. Let us define the process $S = (S_t)_{t \geq 0}$ by

$$S_t = s \exp \left(\left(r - \delta - \frac{\sigma^2}{2} \right) t + \sigma B_t \right) \quad (1.1.1)$$

which solves the stochastic differential equation

$$dS_t = (r - \delta) S_t dt + \sigma S_t dB_t \quad (1.1.2)$$

for $s > 0$, where $\sigma > 0$ and $0 < \delta < r$. Assume that the process S describes the risk-neutral dynamics of the price of a risky asset paying dividends, where r represents the riskless interest rate and δS is the dividend rate paid to stockholders.

We further consider the problem of pricing of the *initial* perpetual American standard *compound* options, which are contracts giving their holders the right to buy or sell some other *underlying* (perpetual American) call or put options at certain (random) exercise times by the (positive) strike prices given. More precisely, the call-on-call (call-on-put) option gives its holder the right to buy at an exercise time τ for the price of K_1 a call (put) option with the strike K_2 (L_2) and exercise time ζ . Furthermore, the put-on-call (put-on-put) option gives its holder the right to sell at an exercise time τ for the price of L_1 a call (put) option with the strike K_2 (L_2) and exercise time ζ . Then, the *rational* (or *no-arbitrage*) prices of such perpetual American contingent claims are given by the values of the optimal stopping problems

$$V_1^*(s) = \sup_{\tau} \sup_{\zeta} E \left[e^{-r\tau} (e^{-r(\zeta-\tau)} (S_{\zeta} - K_2)^+ - K_1)^+ \right] \quad (1.1.3)$$

$$V_2^*(s) = \sup_{\tau} \sup_{\zeta} E \left[e^{-r\tau} (e^{-r(\zeta-\tau)} (L_2 - S_{\zeta})^+ - K_1)^+ \right] \quad (1.1.4)$$

$$V_3^*(s) = \sup_{\tau} \inf_{\zeta} E \left[e^{-r\tau} (L_1 - e^{-r(\zeta-\tau)} (S_{\zeta} - K_2)^+)^+ \right] \quad (1.1.5)$$

$$V_4^*(s) = \sup_{\tau} \inf_{\zeta} E \left[e^{-r\tau} (L_1 - e^{-r(\zeta-\tau)} (L_2 - S_{\zeta})^+)^+ \right] \quad (1.1.6)$$

where the suprema and infima are taken over the sets of stopping times $0 \leq \tau \leq \zeta$ with respect to the natural filtration $(\mathcal{F}_t)_{t \geq 0}$ of the asset price process S , that is $\mathcal{F}_t = \sigma(S_u \mid 0 \leq u \leq t)$, for all $t \geq 0$. Here, the expectations are taken with respect to the equivalent martingale measure under which the dynamics of S started at $s > 0$ are given by (1.1.1)-(1.1.2), and z^+ denotes the positive part $\max\{z, 0\}$ of any $z \in \mathbb{R}$. Note that the payoff of the call-on-call option in (1.1.3) is unbounded, while the payoffs, and thus the related rational prices of the other options in (1.1.4)-(1.1.6), are bounded by L_2 and L_1 , respectively. Moreover, it is easily seen from (1.1.4) and will be shown for (1.1.6) below that the optimal exercise times of the related options are trivial whenever $K_1 \geq L_2$ and $L_1 \geq L_2$ holds, respectively.

Observe that the value functions in (1.1.3)-(1.1.4) are given by the optimal sequential choices of τ and ζ , that results in the suprema over both such stopping times, since the holders of the initial compound options can buy the underlying calls or puts at the time τ and then control the exercise time ζ . This is not the case for the value functions in (1.1.5)-(1.1.6), due to the fact that, in the case in which the holders of the compound options exercise the initial puts at the time τ by selling the underlying calls or puts, they cannot control the subsequent exercise time ζ of the latter options. We should then assume that the holders of the underlying options exercise them optimally. This turns out to be the worst case scenario for the holders of the initial compound options, resulting in the infima over ζ in the expressions of (1.1.5)-(1.1.6).

1.1.2. The structure of the optimal stopping times. The optimal stopping problems formulated above involve the sequential choice of the stopping times τ and ζ . Hence, the initial two-step optimal stopping problems can then be decomposed into sequences of two one-

step optimal stopping problems which can then be solved separately. More precisely, using the strong Markov property of the process S , we further show that the expressions for $V_i^*(s)$, $i = 1, \dots, 4$, in (1.1.3)-(1.1.6) can be reduced to the values of the optimal stopping problems

$$V_i^*(s) = \sup_{\tau} E[e^{-r\tau} H_i^+(S_{\tau})] \quad (1.1.7)$$

where the payoff functions $H_i(s)$, $i = 1, \dots, 4$, are given by

$$H_1(s) = W(s) - K_1, \quad H_2(s) = U(s) - K_1, \quad H_3(s) = L_1 - W(s), \quad H_4(s) = L_1 - U(s) \quad (1.1.8)$$

for all $s > 0$. Here we denote the rational prices of the underlying perpetual American put and call options by $U(s)$ and $W(s)$ with strike prices L_2 and K_2 , respectively. These are given by

$$U(s) = \sup_{\eta} E[e^{-r\eta} (L_2 - S_{\eta})^+] \quad \text{and} \quad W(s) = \sup_{\eta} E[e^{-r\eta} (S_{\eta} - K_2)^+] \quad (1.1.9)$$

where the suprema are taken over the stopping times η of the process S started at $s > 0$. It is well known (see, e.g. [105; Chapter VIII, Section 2a]) that the value functions in (1.1.9) are continuously differentiable and have the form

$$U(s) = \begin{cases} -(g_*/\gamma_-)(s/g_*)^{\gamma_-}, & \text{if } s > g_* \\ L_2 - s, & \text{if } s \leq g_* \end{cases} \quad (1.1.10)$$

and

$$W(s) = \begin{cases} (h_*/\gamma_+)(s/h_*)^{\gamma_+}, & \text{if } s < h_* \\ s - K_2, & \text{if } s \geq h_* \end{cases} \quad (1.1.11)$$

The optimal exercise times have the structure

$$\eta_g^* = \inf\{t \geq 0 \mid S_t \leq g_*\} \quad \text{and} \quad \eta_h^* = \inf\{t \geq 0 \mid S_t \geq h_*\} \quad (1.1.12)$$

and the hitting boundaries are given by

$$g_* = \frac{\gamma_- L_2}{\gamma_- - 1} \quad \text{and} \quad h_* = \frac{\gamma_+ K_2}{\gamma_+ - 1} \quad (1.1.13)$$

with

$$\gamma_{\pm} = \frac{1}{2} - \frac{r - \delta}{\sigma^2} \pm \sqrt{\left(\frac{1}{2} - \frac{r - \delta}{\sigma^2}\right)^2 + \frac{2r}{\sigma^2}} \quad (1.1.14)$$

so that $\gamma_- < 0 < 1 < \gamma_+$ holds.

It follows from the general theory of optimal stopping for Markov processes (see, e.g. [97; Chapter I, Section 2.2]) that the optimal stopping times in the problems of (1.1.7)-(1.1.8) are given by

$$\tau_i^* = \inf\{t \geq 0 \mid V_i^*(S_t) = H_i^+(S_t)\} \quad (1.1.15)$$

whenever they exist. Analysing the structure of the outer and inner payoffs in (1.1.3)-(1.1.6), we observe that the call-on-call and put-on-put options should be exercised at the first time at which the price of the underlying risky asset rises to some upper levels b_i^* , while the call-on-put and put-on-call options should be exercised at the first time at which the asset price falls to some lower levels a_i^* . Hence, we need further to search for optimal stopping times in the problems of (1.1.7)-(1.1.8) in the form

$$\tau_i^* = \inf\{t \geq 0 \mid S_t \leq a_i^*\} \quad \text{or} \quad \tau_i^* = \inf\{t \geq 0 \mid S_t \geq b_i^*\} \quad (1.1.16)$$

for some $a_i^* > 0$ and $b_i^* > 0$ to be determined, where the left-hand stopping time in (1.1.16) is optimal for the cases of $i = 2, 3$, and the right-hand one is optimal for the cases of $i = 1, 4$. Taking into account the structure of the stopping times in (1.1.12), we then further assume that the optimal stopping times ζ_i^* in (1.1.3)-(1.1.6) have the form

$$\zeta_i^* = \inf\{t \geq \tau_i^* \mid S_t \leq g_*\} \quad \text{or} \quad \zeta_i^* = \inf\{t \geq \tau_i^* \mid S_t \geq h_*\} \quad (1.1.17)$$

depending on the view of the payoff functions of the underlying options.

1.1.3. The free-boundary problem. It can be shown by means of standard arguments (see, e.g. [69; Chapter V, Section 5.1] or [86; Chapter VII, Section 7.3]) that the infinitesimal operator \mathbb{L} of the process S acts on an arbitrary twice continuously differentiable locally bounded function $F(s)$ according to the rule

$$(\mathbb{L}F)(s) = (r - \delta) s F'(s) + \frac{\sigma^2}{2} s^2 F''(s) \quad (1.1.18)$$

for all $s > 0$. In order to find explicit expressions for the unknown value functions $V_i^*(s)$, $i = 1, \dots, 4$, from (1.1.7)-(1.1.8) and the unknown boundaries a_i^* and b_i^* from (1.1.16), we may use the results of the general theory of optimal stopping problems for continuous time Markov processes (see, e.g. [104; Chapter III, Section 8] and [97; Chapter IV, Section 8]). We formulate the associated free-boundary problems

$$(\mathbb{L}V_i)(s) = rV_i(s) \quad \text{for} \quad s > a_i \quad \text{or} \quad s < b_i \quad (1.1.19)$$

$$V_i(a_i+) = H_i^+(a_i) \quad \text{or} \quad V_i(b_i-) = H_i^+(b_i) \quad (\text{instantaneous stopping}) \quad (1.1.20)$$

$$V_i'(a_i+) = H_i^{+'}(a_i) \quad \text{or} \quad V_i'(b_i-) = H_i^{+'}(b_i) \quad (\text{smooth fit}) \quad (1.1.21)$$

$$V_i(s) = H_i^+(s) \quad \text{for} \quad s < a_i \quad \text{or} \quad s > b_i \quad (1.1.22)$$

$$V_i(s) > H_i^+(s) \quad \text{for} \quad s > a_i \quad \text{or} \quad s < b_i \quad (1.1.23)$$

$$(\mathbb{L}V_i)(s) < rV_i(s) \quad \text{for} \quad s < a_i \quad \text{or} \quad s > b_i \quad (1.1.24)$$

for some $a_i > 0$ and $b_i > 0$ fixed, depending on the structure of the payoff $H_i^+(s)$ in (1.1.8), for every $i = 1, \dots, 4$.

1.2. Solutions of the free-boundary problems

We further derive solutions of the free-boundary problems related to the optimal stopping problems in (1.1.7)-(1.1.8), by specifying whether the left-hand or the right-hand part of the system in (1.1.19)-(1.1.24) is realised in every case of $i = 1, \dots, 4$. For this we first note that the general solution of the second order ordinary differential equation in (1.1.19) is given by

$$V_i(s) = C_{+,i} s^{\gamma_+} + C_{-,i} s^{\gamma_-} \quad (1.2.1)$$

where $C_{+,i}$ and $C_{-,i}$ are some arbitrary constants, and $\gamma_- < 0 < 1 < \gamma_+$ are defined in (1.1.14). Observe that we should have $C_{-,i} = 0$ in (1.2.1) when the right-hand part of the system in (1.1.19)-(1.1.24) is realised, since otherwise $V_i(s) \rightarrow \pm\infty$, which must be excluded because the value functions in (1.1.7) are bounded under $s \downarrow 0$. Similarly, we should also have $C_{+,i} = 0$ in (1.2.1) when the left-hand part of the system in (1.1.19)-(1.1.24) is realised, since otherwise $V_i(s) \rightarrow \pm\infty$, which must be excluded because the value functions in (1.1.7) are less than s under $s \uparrow \infty$.

1.2.1. The call-on-call option. Let us first consider the case of $i = 1$ in which the right-hand stopping time from (1.1.16) is optimal in (1.1.3) and (1.1.7)-(1.1.8), so that the right-hand part of the free-boundary problem is realised in (1.1.19)-(1.1.24). Applying the conditions of the right-hand parts of the equations in (1.1.20) and (1.1.21) to the function in (1.2.1) with $C_{-,1} = 0$, we obtain after some rearrangements that if $b_1 < h_*$ then the equalities

$$C_{+,1} b_1^{\gamma_+} = \frac{h_*}{\gamma_+} \left(\frac{b_1}{h_*} \right)^{\gamma_+} - K_1 \quad \text{and} \quad C_{+,1} \gamma_+ b_1^{\gamma_+} = h_* \left(\frac{b_1}{h_*} \right)^{\gamma_+} \quad (1.2.2)$$

should hold, and if $b_1 \geq h_*$ then the equalities

$$C_{+,1} b_1^{\gamma_+} = b_1 - K_2 - K_1 \quad \text{and} \quad C_{+,1} \gamma_+ b_1^{\gamma_+} = b_1 \quad (1.2.3)$$

are satisfied for some $C_{+,1}$ and $b_1 > 0$, where h_* is given by (1.1.13). Multiplying the first equation in (1.2.2) by γ_+ , we conclude from the second one there that the system in (1.1.19)-(1.1.21) does not have solutions, so that the subcase $b_1^* < h_*$ cannot be realised. Solving the system in (1.2.3), we obtain the solution of the right-hand part of the system in (1.1.19)-(1.1.21) having the form

$$V_1(s; b_1^*) = \frac{b_1^*}{\gamma_+} \left(\frac{s}{b_1^*} \right)^{\gamma_+} \quad \text{with} \quad b_1^* = \frac{\gamma_+(K_1 + K_2)}{\gamma_+ - 1} \equiv \frac{\gamma_+ K_1}{\gamma_+ - 1} + h_*. \quad (1.2.4)$$

1.2.2. The call-on-put option. Let us then proceed with the case of $i = 2$ in which the left-hand stopping time from (1.1.16) is optimal in (1.1.4) and (1.1.7)-(1.1.8), so that the left-hand part of the free-boundary problem is realised in (1.1.19)-(1.1.24). Applying the conditions

of the left-hand parts of the equations in (1.1.20) and (1.1.21) to the function in (1.2.1) with $C_{+,2} = 0$, we obtain after some rearrangements that if $a_2 > g_*$ then the equalities

$$C_{-,2} a_2^{\gamma_-} = -\frac{g_*}{\gamma_-} \left(\frac{a_2}{g_*}\right)^{\gamma_-} - K_1 \quad \text{and} \quad C_{-,2} \gamma_- a_2^{\gamma_-} = -g_* \left(\frac{a_2}{g_*}\right)^{\gamma_-} \quad (1.2.5)$$

should hold, and if $a_2 \leq g_*$ then the equalities

$$C_{-,2} a_2^{\gamma_-} = L_2 - a_2 - K_1 \quad \text{and} \quad C_{-,2} \gamma_- a_2^{\gamma_-} = -a_2 \quad (1.2.6)$$

are satisfied for some $C_{-,2}$ and $a_2 > 0$, where g_* is given by (1.1.13). Multiplying the first equation in (1.2.5) by γ_- , we conclude from the second one there that the system in (1.1.19)-(1.1.21) does not have solutions, so that the subcase $a_2^* > g_*$ cannot be realised. Solving the system in (1.2.6), we obtain the solution of the left-hand part of the system in (1.1.19)-(1.1.21) having the form

$$V_2(s; a_2^*) = -\frac{a_2^*}{\gamma_-} \left(\frac{s}{a_2^*}\right)^{\gamma_-} \quad \text{with} \quad a_2^* = \frac{\gamma_-(L_2 - K_1)}{\gamma_- - 1} \equiv g_* - \frac{\gamma_- K_1}{\gamma_- - 1} \quad (1.2.7)$$

where the number a_2^* is strictly positive if and only if $L_2 > K_1$.

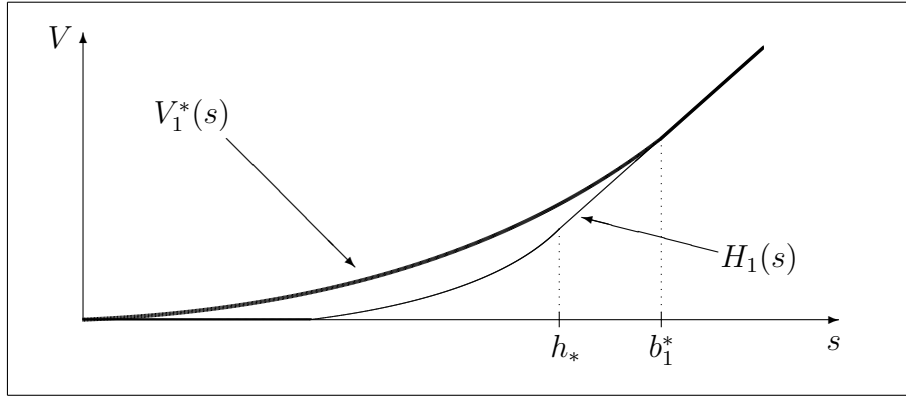

Figure 1. A computer drawing of the payoff function $H_1(s)$ and the resulting value function $V_1^*(s)$.

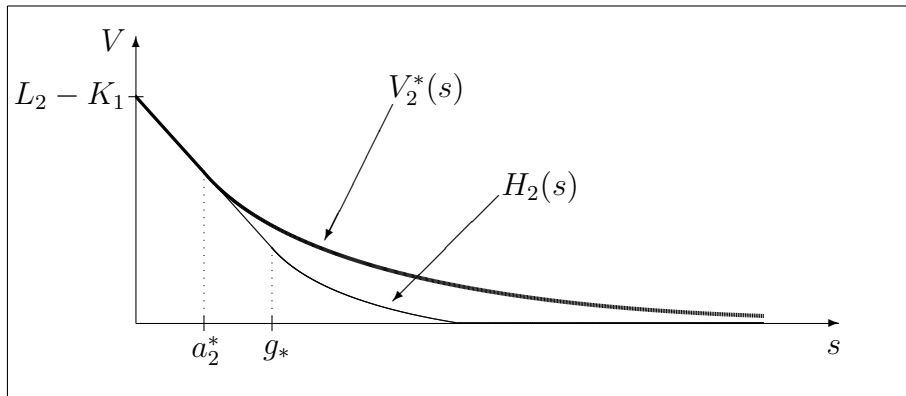

Figure 2. A computer drawing of the payoff function $H_2(s)$ and the resulting value function $V_2^*(s)$.

1.2.3. The put-on-call option. Let us now continue with the case of $i = 3$ in which the left-hand stopping time from (1.1.16) is optimal in (1.1.5) and (1.1.7)-(1.1.8), so that the left-hand part of the free-boundary problem is realised in (1.1.19)-(1.1.24). Applying the conditions of the left-hand parts of the equations in (1.1.20) and (1.1.21) to the function in (1.2.1) with $C_{+,3} = 0$, we get after some rearrangements that if $a_3 < h_*$ then the equalities

$$C_{-,3} a_3^{\gamma_-} = L_1 - \frac{h_*}{\gamma_+} \left(\frac{a_3}{h_*} \right)^{\gamma_+} \quad \text{and} \quad C_{-,3} \gamma_- a_3^{\gamma_-} = -h_* \left(\frac{a_3}{h_*} \right)^{\gamma_+} \quad (1.2.8)$$

hold, and if $a_3 \geq h_*$ then the equalities

$$C_{-,3} a_3^{\gamma_-} = L_1 - a_3 + K_2 \quad \text{and} \quad C_{-,3} \gamma_- a_3^{\gamma_-} = -a_3 \quad (1.2.9)$$

are satisfied for some $C_{-,3}$ and $a_3 > 0$, where h_* is given by (1.1.13). Solving the systems in (1.2.8) and (1.2.9), we conclude that the two regions for L_1 and K_2 , with qualitatively different solutions of the free-boundary problem, can be distinguished. By means of straightforward computations, if the condition

$$L_1 < \frac{\gamma_- - \gamma_+}{\gamma_+ \gamma_-} h_* \equiv \frac{(\gamma_- - \gamma_+) K_2}{\gamma_- (\gamma_+ - 1)} \quad (1.2.10)$$

is satisfied, then $a_3^* < h_*$ holds and the solution of the left-hand part of the system in (1.1.19)-(1.1.21) has the form

$$V_3(s; a_3^*, h_*) = -\frac{h_*}{\gamma_-} \left(\frac{a_3^*}{h_*} \right)^{\gamma_+} \left(\frac{s}{a_3^*} \right)^{\gamma_-} \quad (1.2.11)$$

with

$$a_3^* = h_* \left(\frac{\gamma_+ \gamma_- L_1}{(\gamma_- - \gamma_+) h_*} \right)^{1/\gamma_+} \equiv \frac{\gamma_+ K_2}{\gamma_+ - 1} \left(\frac{\gamma_- (\gamma_+ - 1) L_1}{(\gamma_- - \gamma_+) K_2} \right)^{1/\gamma_+}. \quad (1.2.12)$$

Using similar arguments, if the condition

$$L_1 \geq \frac{\gamma_- - \gamma_+}{\gamma_+ \gamma_-} h_* \equiv \frac{(\gamma_- - \gamma_+) K_2}{\gamma_- (\gamma_+ - 1)} \quad (1.2.13)$$

is satisfied, then $a_3^* \geq h_*$ holds and the solution of the left-hand part of the system in (1.1.19)-(1.1.21) has the form

$$V_3(s; a_3^*) = -\frac{a_3^*}{\gamma_-} \left(\frac{s}{a_3^*} \right)^{\gamma_-} \quad \text{with} \quad a_3^* = \frac{\gamma_- (L_1 + K_2)}{\gamma_- - 1}. \quad (1.2.14)$$

1.2.4. The put-on-put option. Let us finally consider the case of $i = 4$ in which the right-hand stopping time from (1.1.16) is optimal in (1.1.6) and (1.1.7)-(1.1.8), so that the right-hand part of the free-boundary problem is realised in (1.1.19)-(1.1.24). Applying the conditions of the right-hand parts of the equations in (1.1.20) and (1.1.21) to the function in (1.2.1) with $C_{-,4} = 0$, we get after some rearrangements that if $b_4 > g_*$ then the equalities

$$C_{+,4} b_4^{\gamma_+} = L_1 + \frac{g_*}{\gamma_-} \left(\frac{b_4}{g_*} \right)^{\gamma_-} \quad \text{and} \quad C_{+,4} \gamma_+ b_4^{\gamma_+} = g_* \left(\frac{b_4}{g_*} \right)^{\gamma_-} \quad (1.2.15)$$

hold, and if $b_4 \leq g_*$ then the equalities

$$C_{+,4} b_4^{\gamma_+} = L_1 - L_2 + b_4 \quad \text{and} \quad C_{+,4} \gamma_+ b_4^{\gamma_+} = b_4 \quad (1.2.16)$$

are satisfied for some $C_{+,4}$ and $b_4 > 0$. Solving the systems in (1.2.15) and (1.2.16), we conclude that the two regions for L_1 and L_2 , with qualitatively different solutions of the free-boundary problem (besides the trivial solution in the case $L_1 \geq L_2$), can be distinguished. By means of straightforward computations, if the condition

$$L_1 < \frac{\gamma_- - \gamma_+}{\gamma_+ \gamma_-} g_* \equiv \frac{(\gamma_- - \gamma_+) L_2}{\gamma_+ (\gamma_- - 1)} \quad (1.2.17)$$

is satisfied, then $b_4^* > g_*$ holds and the solution of the left-hand part of the system in (1.1.19)-(1.1.21) has the form

$$V_4(s; b_4^*, g_*) = \frac{g_*}{\gamma_+} \left(\frac{b_4^*}{g_*} \right)^{\gamma_-} \left(\frac{s}{b_4^*} \right)^{\gamma_+} \quad (1.2.18)$$

with

$$b_4^* = g_* \left(\frac{\gamma_+ \gamma_- L_1}{(\gamma_- - \gamma_+) g_*} \right)^{1/\gamma_-} \equiv \frac{\gamma_- L_2}{\gamma_- - 1} \left(\frac{\gamma_+ (\gamma_- - 1) L_1}{(\gamma_- - \gamma_+) L_2} \right)^{1/\gamma_-}. \quad (1.2.19)$$

Using similar arguments, if the condition

$$L_1 \geq \frac{\gamma_- - \gamma_+}{\gamma_+ \gamma_-} g_* \equiv \frac{(\gamma_- - \gamma_+) L_2}{\gamma_+ (\gamma_- - 1)} \quad (1.2.20)$$

is satisfied, then $b_4^* \leq g_*$ holds and the solution of the left-hand part of the system in (1.1.19)-(1.1.21) has the form

$$V_4(s; b_4^*) = \frac{b_4^*}{\gamma_+} \left(\frac{s}{b_4^*} \right)^{\gamma_+} \quad \text{with} \quad b_4^* = \frac{\gamma_+ (L_2 - L_1)}{\gamma_+ - 1} \quad (1.2.21)$$

where the number b_4^* is strictly positive if and only if $L_2 > L_1$.

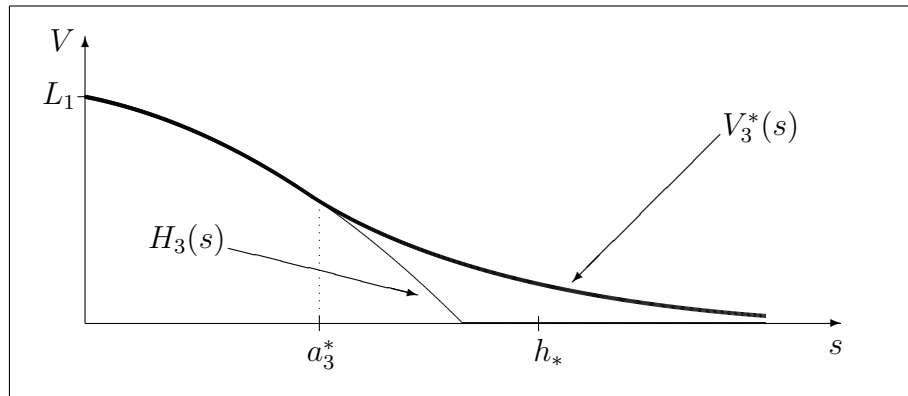

Figure 3. A computer drawing of the payoff function $H_3(s)$ and the value function $V_3^*(s)$, when (1.2.10) holds for L_1 and L_2 .

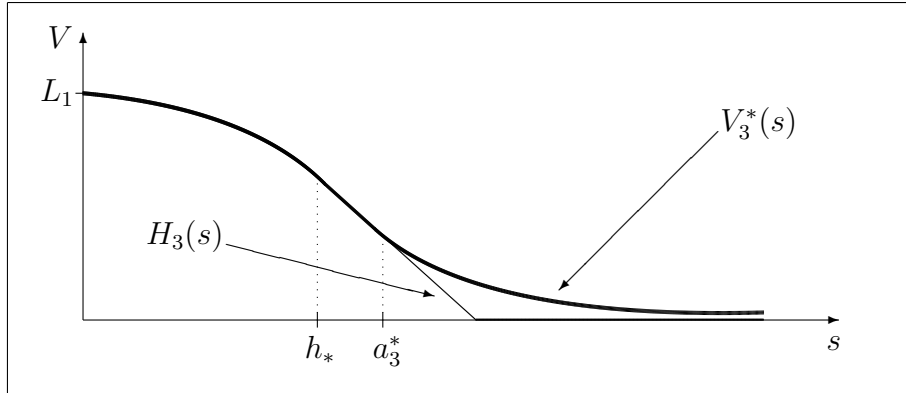

Figure 4. A computer drawing of the payoff function $H_3(s)$ and the value function $V_3^*(s)$, when (1.2.13) holds for L_1 and K_2 .

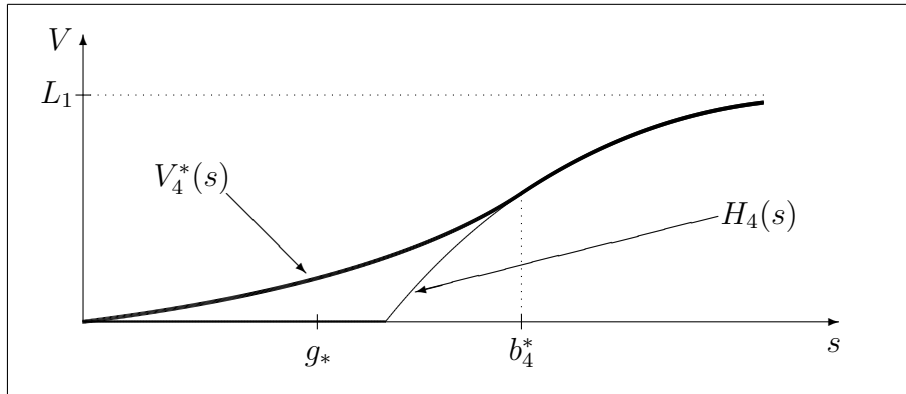

Figure 5. A computer drawing of the payoff function $H_4(s)$ and the value function $V_4^*(s)$, when (1.2.17) holds for L_1 and L_2 .

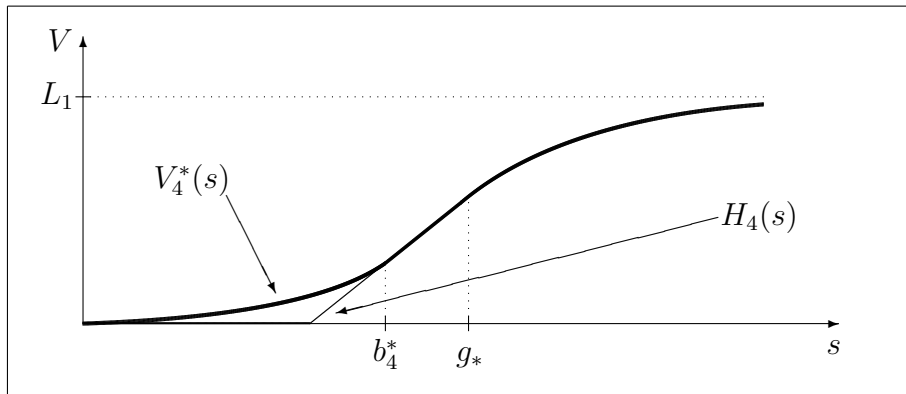

Figure 6. A computer drawing of the payoff function $H_4(s)$ and the value function $V_4^*(s)$, when (1.2.20) holds for L_1 and L_2 .

1.3. Main results and proofs

Taking into account the facts proved above, let us now formulate the main assertions of the chapter. We recall that the price process S of the underlying risky asset is defined in (1.1.1)-(1.1.2), and the exercise boundaries g_* and h_* for the underlying perpetual American put and call options are given by (1.1.13).

Proposition 1.3.1 *In the optimal stopping problem of (1.1.3), related to the perpetual American call-on-call option with strike prices $K_1 > 0$ and $K_2 > 0$ of the outer and inner payoffs, respectively, the value function has the form*

$$V_1^*(s) = \begin{cases} V_1(s; b_1^*), & \text{if } s < b_1^* \\ (s - K_2) - K_1, & \text{if } s \geq b_1^* \end{cases} \quad (1.3.1)$$

where the function $V_1(s; b_1^*)$ and the hitting boundary $b_1^* \geq h_*$ for the right-hand optimal exercise time τ_1^* in (1.1.16) are given by (1.2.4) (see Figure 1 above).

Proposition 1.3.2 *In the optimal stopping problem of (1.1.4), related to the perpetual American call-on-put option with strike prices $0 < K_1 < L_2$ of the outer and inner payoffs, respectively, the value function has the form*

$$V_2^*(s) = \begin{cases} V_2(s; a_2^*), & \text{if } s > a_2^* \\ (L_2 - s) - K_1, & \text{if } s \leq a_2^* \end{cases} \quad (1.3.2)$$

where the function $V_2(s; a_2^*)$ and the hitting boundary $a_2^* \leq g_*$ for the left-hand optimal exercise time τ_2^* in (1.1.16) are given by (1.2.7) (see Figure 2 above), while $V_2^*(s) = 0$ and $\tau_2^* = 0$ whenever $K_1 \geq L_2$.

Proposition 1.3.3 *In the optimal stopping problem of (1.1.5), related to the perpetual American put-on-call option with strike prices $L_1 > 0$ and $K_2 > 0$ of the outer and inner payoffs, respectively, the following assertions hold:*

(i) if (1.2.10) holds for L_1 and K_2 then the value function has the form:

$$V_3^*(s) = \begin{cases} V_3(s; a_3^*, h_*), & \text{if } s > a_3^* \\ L_1 - (h_*/\gamma_+)(s/h_*)^{\gamma_+}, & \text{if } s \leq a_3^* \end{cases} \quad (1.3.3)$$

where the function $V_3(s; a_3^*, h_*)$ and the hitting boundary $a_3^* < h_*$ for the left-hand optimal exercise time τ_3^* in (1.1.16) are given by (1.2.11) and (1.2.12), respectively (see Figure 3 above);

(ii) if (1.2.13) holds for L_1 and K_2 then the value function has the form:

$$V_3^*(s) = \begin{cases} V_3(s; a_3^*), & \text{if } s > a_3^* \\ L_1 - (s - K_2), & \text{if } h_* \leq s \leq a_3^* \\ L_1 - (h_*/\gamma_+)(s/h_*)^{\gamma_+}, & \text{if } s < h_* \end{cases} \quad (1.3.4)$$

where the function $V_3(s; a_3^*)$ and the hitting boundary a_3^* for the left-hand optimal exercise time τ_3^* in (1.1.16) are given by (1.2.14) (see Figure 4 above).

Proposition 1.3.4 *In the optimal stopping problem of (1.1.6), related to the perpetual American put-on-put option with strike prices $L_1 > 0$ and $L_2 > 0$ of the outer and inner payoffs, respectively, the following assertions hold:*

(i) if (1.2.17) holds for L_1 and L_2 , then the value function has the form

$$V_4^*(s) = \begin{cases} V_4(s; b_4^*, g_*), & \text{if } s < b_4^* \\ L_1 + (g_*/\gamma_-)(s/g_*)^{\gamma_-}, & \text{if } s \geq b_4^* \end{cases} \quad (1.3.5)$$

where the function $V_4(s; b_4^*, g_*)$ and the hitting boundary $b_4^* > g_*$ for the right-hand optimal exercise time τ_4^* in (1.1.16) are given by (1.2.18) and (1.2.19), respectively (see Figure 5 above);

(ii) if (1.2.20) holds with $L_1 < L_2$, then the value function has the form

$$V_4^*(s) = \begin{cases} V_4(s; b_4^*), & \text{if } s < b_4^* \\ L_1 - (L_2 - s), & \text{if } b_4^* \leq s \leq g_* \\ L_1 + (g_*/\gamma_-)(s/g_*)^{\gamma_-}, & \text{if } s > g_* \end{cases} \quad (1.3.6)$$

where the function $V_4(s; b_4^*)$ and the hitting boundary b_4^* for the right-hand optimal exercise time τ_4^* in (1.1.16) are given by (1.2.21) (see Figure 6 above), while $V_4^*(s) = L_1 - (L_2 - s)$ and $\tau_4^* = 0$ whenever $L_1 \geq L_2$.

Since all the assertions formulated above are proved using similar arguments, we only give a proof for the problem related to the perpetual American put-on-call option, which represents the most complicated and informative case.

Proof of Proposition 1.3.3. In order to verify the assertion stated above, it remains to show that the function $V_3^*(s)$ defined in either (1.3.3) or (1.3.4) coincides with the value function in (1.1.5), and that the stopping time τ_3^* in the left-hand side of (1.1.16) is optimal with a_3^* given by either (1.2.12) or (1.2.14). Let us denote by $V_3(s)$ the right-hand side of the expression in

(1.3.3) or (1.3.4). Applying the local time-space formula from [91] (see also [97; Chapter II, Section 3.5] for a summary of the related results as well as further references) and taking into account the smooth-fit condition in (1.1.21) and the smoothness of the functions in (1.1.10)-(1.1.11), the following expressions

$$e^{-rt} V_3(S_t) = V_3(s) + \int_0^t e^{-ru} (\mathbb{L}V_3 - rV_3)(S_u) I(S_u \neq a_3^*) du + M_t \quad (1.3.7)$$

$$e^{-rt} W(S_t) = W(s) + \int_0^t e^{-ru} (\mathbb{L}W - rW)(S_u) I(S_u \neq h_*) du + N_t \quad (1.3.8)$$

hold, where $I(\cdot)$ denotes the indicator function and the processes $M = (M_t)_{t \geq 0}$ and $N = (N_t)_{t \geq 0}$ defined by

$$M_t = \int_0^t e^{-ru} V_3'(S_u) \sigma S_u dB_u \quad \text{and} \quad N_t = \int_0^t e^{-ru} W'(S_u) \sigma S_u dB_u \quad (1.3.9)$$

are continuous square integrable martingales with respect to the probability measure P . The latter fact can easily be observed, since the derivatives $V_3'(s)$ and $W'(s)$ are bounded functions.

By means of straightforward calculations similar to those of the previous section, it can be verified that the conditions of (1.1.23) and (1.1.24) hold with a_3^* given by either (1.2.12) or (1.2.14). These facts together with the conditions in (1.1.19)-(1.1.20) and (1.1.22) yield that $(\mathbb{L}V_3 - rV_3)(s) \leq 0$ holds for all $s \neq a_3^*$, and $V_3(s) \geq (L_1 - W(s))^+$ is satisfied for all $s > 0$. It is well known (see, e.g. [105; Chapter VIII, Section 2a]) that $(\mathbb{L}W - rW)(s) \leq 0$ holds for all $s \neq h_*$, and $W(s) \geq (s - K_2)^+$ is satisfied for all $s > 0$. Moreover, since the time spent by the process S at the boundaries a_3^* and h_* is of Lebesgue measure zero, the indicators which appear in the integrals of (1.3.7)-(1.3.8) can be ignored. Hence, it follows from the expressions in (1.3.7)-(1.3.8) that the inequalities

$$e^{-r(\tau \wedge t)} (L_1 - W(S_{\tau \wedge t}))^+ \leq e^{-r(\tau \wedge t)} V_3(S_{\tau \wedge t}) \leq V_3(s) + M_{\tau \wedge t} \quad (1.3.10)$$

$$e^{-r(\zeta \wedge u)} (S_{\zeta \wedge u} - K_2)^+ \leq e^{-r(\zeta \wedge u)} W(S_{\zeta \wedge u}) \leq e^{-r(\tau \wedge t)} W(S_{\tau \wedge t}) + N_{\zeta \wedge u} - N_{\tau \wedge t} \quad (1.3.11)$$

hold for all $0 \leq t \leq u$ and any stopping times $0 \leq \tau \leq \zeta$ of the process S started at $s > 0$. Then, taking the (conditional) expectations with respect to P in (1.3.10)-(1.3.11), by means of Doob's optional sampling theorem (see, e.g. [79; Theorem 3.6] or [69; Chapter I, Theorem 3.22]), we get that the inequalities

$$E[e^{-r(\tau \wedge t)} (L_1 - W(S_{\tau \wedge t}))^+] \leq E[e^{-r(\tau \wedge t)} V_3(S_{\tau \wedge t})] \leq V_3(s) + E[M_{\tau \wedge t}] = V_3(s) \quad (1.3.12)$$

$$\begin{aligned} E[e^{-r(\zeta \wedge u)} (S_{\zeta \wedge u} - K_2)^+ | \mathcal{F}_{\tau \wedge t}] &\leq E[e^{-r(\zeta \wedge u)} W(S_{\zeta \wedge u}) | \mathcal{F}_{\tau \wedge t}] \\ &\leq e^{-r(\tau \wedge t)} W(S_{\tau \wedge t}) + E[N_{\zeta \wedge u} - N_{\tau \wedge t} | \mathcal{F}_{\tau \wedge t}] = e^{-r(\tau \wedge t)} W(S_{\tau \wedge t}) \quad (P\text{-a.s.}) \end{aligned} \quad (1.3.13)$$

hold for all $s > 0$. Thus, letting u and then t go to infinity and using (conditional) Fatou's lemma, we obtain

$$E[e^{-r\tau} (L_1 - W(S_\tau))] \leq E[e^{-r\tau} (L_1 - W(S_\tau))^+] \leq E[e^{-r\tau} V_3(S_\tau)] \leq V_3(s) \quad (1.3.14)$$

$$E[e^{-r\zeta} (S_\zeta - K_2)^+ | \mathcal{F}_\tau] \leq E[e^{-r\zeta} W(S_\zeta) | \mathcal{F}_\tau] \leq e^{-r\tau} W(S_\tau) \quad (P\text{-a.s.}) \quad (1.3.15)$$

for any stopping times $0 \leq \tau \leq \zeta$ and all $s > 0$. By virtue of the structure of the stopping times in (1.1.16) and (1.1.17), it is readily seen that the equalities in (1.3.14)-(1.3.15) hold with τ_3^* and ζ_3^* instead of τ and ζ , when $s \leq a_3^*$ and $S_{\tau_3^*} \geq h_*$ (P -a.s.).

It remains to be shown that the equalities are attained in (1.3.14)-(1.3.15) when τ_3^* and ζ_3^* replace τ and ζ , respectively, when $s > a_3^*$ and $S_{\tau_3^*} < h_*$ (P -a.s.). By virtue of the fact that the function $V_3(s; a_3^*, h_*)$ and the boundary a_3^* satisfy the conditions in (1.1.19) and (1.1.20) as well as for the function $W(s)$ and the boundary h_* the condition $(\mathbb{L}W - rW)(s) = 0$ is satisfied for $s < h_*$ and $W(h_* -) = h_* - K_2$ holds, it follows from the expressions in (1.3.7)-(1.3.8) and the structure of the stopping times τ_3^* and ζ_3^* in (1.1.16) and (1.1.17) that the equalities

$$e^{-r(\tau_3^* \wedge t)} V_3(S_{\tau_3^* \wedge t}) = V_3(s) + M_{\tau_3^* \wedge t} \quad (1.3.16)$$

$$e^{-r(\zeta_3^* \wedge u)} W(S_{\zeta_3^* \wedge u}) = e^{-r(\tau_3^* \wedge t)} W(S_{\tau_3^* \wedge t}) + N_{\zeta_3^* \wedge u} - N_{\tau_3^* \wedge t} \quad (1.3.17)$$

are satisfied for all $0 \leq t \leq u$, when $s > a_3^*$ and $S_{\tau_3^*} < h_*$ (P -a.s.), and where the processes M and N are defined in (1.3.9). Taking into account the fact that $V_3(s)$ is bounded by L_1 from above and the properties of the function $W(s)$ in (1.1.11) (see, e.g. [105; Chapter VIII, Section 2a]), we conclude from (1.3.16)-(1.3.17) that the variables $e^{-r\tau_3^*} V_3(S_{\tau_3^*})$ and $e^{-r\zeta_3^*} W(S_{\zeta_3^*})$ are equal to zero on the events $\{\tau_3^* = \infty\}$ and $\{\zeta_3^* = \infty\}$ (P -a.s.), respectively, and the processes $(M_{\tau_3^* \wedge t})_{t \geq 0}$ and $(N_{\zeta_3^* \wedge t})_{t \geq 0}$ are uniformly integrable martingales. Therefore, taking the (conditional) expectations with respect to P and letting u and then t go to infinity, we apply the (conditional) Lebesgue dominated convergence theorem to obtain the equalities

$$E[e^{-r\tau_3^*} (L_1 - W(S_{\tau_3^*}))] = E[e^{-r\tau_3^*} (L_1 - W(S_{\tau_3^*}))^+] = E[e^{-r\tau_3^*} V_3(S_{\tau_3^*})] = V_3(s) \quad (1.3.18)$$

$$E[e^{-r\zeta_3^*} (S_{\zeta_3^*} - K_2)^+ | \mathcal{F}_{\tau_3^*}] = E[e^{-r\zeta_3^*} W(S_{\zeta_3^*}) | \mathcal{F}_{\tau_3^*}] = e^{-r\tau_3^*} W(S_{\tau_3^*}) \quad (P\text{-a.s.}) \quad (1.3.19)$$

for all $s > a_3^*$ and $S_{\tau_3^*} < h_*$ (P -a.s.). The latter, together with the inequalities in (1.3.14)-(1.3.15), imply the fact that $V_3(s)$ coincides with the function $V_3^*(s)$ from (1.1.5), and τ_3^* and ζ_3^* from (1.1.16) and (1.1.17) are the optimal stopping times. \square

Remark 1.3.5 Note that in the cases of call-on-call and call-on-put options in Propositions 1.3.1 and 1.3.2 above, one should not stop the underlying process S when $s < b_1^*$ and $s > a_2^*$, respectively. However, both the initial and underlying options should be exercised immediately when $s \geq b_1^*$ and $s \leq a_2^*$, accordingly. Moreover, in the case of put-on-call option in Proposition

1.3.3 above, one should not stop the underlying process when $s > a_3^*$ holds, one should exercise the initial option only when either $s \leq a_3^*$ under (1.2.10) or $s < h_*$ under (1.2.13) is satisfied, while both the initial and underlying options should be exercised immediately when $h_* \leq s \leq a_3^*$ holds under (1.2.13). Similarly, in the case of put-on-put option in Proposition 1.3.4 above, one should not stop the underlying process when $s < b_4^*$, one should exercise the initial option only when either $s \geq b_4^*$ under (1.2.17) or $s > g_*$ under (1.2.20) is satisfied with $L_1 < L_2$, while both the initial and underlying options should be exercised immediately when $b_4^* \leq s \leq g_*$ holds under (1.2.20) with $L_1 < L_2$.

1.4. Chooser options

In this section, we give a formulation of the perpetual American chooser option optimal stopping problem and prove the uniqueness of solution of the associated free-boundary problem.

1.4.1. Formulation of the problem. Let us finally consider the perpetual American *chooser* option which is a contract giving its holder the right to decide at an exercise time τ whether the initial compound option acts further as the underlying perpetual American put or call option. Then, according to the arguments above, the rational price of such a contingent claim is given by the value of the optimal stopping problem

$$V^*(s) = \sup_{\tau} E[e^{-r\tau} (U(S_{\tau}) \vee W(S_{\tau}))] \quad (1.4.1)$$

where the supremum is taken over the stopping times τ of the process S started at $s > 0$, and $x \vee y$ denotes the maximum $\max\{x, y\}$ of any $x, y \in \mathbb{R}$. Recall that the functions $U(s)$ and $W(s)$ represent the rational prices of the underlying perpetual American put and call options defined in (1.1.9), respectively. By virtue of the structure of the resulting convex and strictly monotone value functions in (1.1.10)-(1.1.11), we further search for an optimal stopping time in the problem of (1.4.1) of the form

$$\tau^* = \inf\{t \geq 0 \mid S_t \notin (p_*, q_*)\} \quad (1.4.2)$$

for some numbers $0 < p_* < c < q_* < \infty$ to be determined, where c denotes the point of intersection of the curves associated with the functions $U(s)$ and $W(s)$ (see Figure 8 below). Note that the latter inequalities always hold, since we have $U'(c-) < 0 < W'(c+)$, so that it is never optimal to exercise the option at $s = c$ (see, e.g. [24; Section 4] or [47; Section 3]).

In order to find explicit expressions for the unknown value function $V^*(s)$ from (1.4.1) and the unknown boundaries p_* and q_* from (1.4.2), we follow the schema of arguments above and

formulate the free-boundary problem

$$(\mathbb{L}V)(s) = rV(s) \quad \text{for } p < s < q \quad (1.4.3)$$

$$V(p+) = U(p) \quad \text{and} \quad V(q-) = W(q) \quad (\text{instantaneous stopping}) \quad (1.4.4)$$

$$V'(p+) = U'(p) \quad \text{and} \quad V'(q-) = W'(q) \quad (\text{smooth fit}) \quad (1.4.5)$$

$$V(s) = U(s) \vee W(s) \quad \text{for } s < p \quad \text{and} \quad s > q \quad (1.4.6)$$

$$V(s) > U(s) \vee W(s) \quad \text{for } p < s < q \quad (1.4.7)$$

$$(\mathbb{L}V)(s) < rV(s) \quad \text{for } s < p \quad \text{and} \quad s > q \quad (1.4.8)$$

for some $0 < p < c < q < \infty$ fixed.

1.4.2. Solution of the free-boundary problem. In order to solve the free-boundary problem in (1.4.3)-(1.4.8), we first recall that the general solution of the differential equation in (1.4.3) has the form of (1.2.1) with some arbitrary constants C_+ and C_- . Hence, applying the instantaneous stopping conditions from (1.4.4) to the function in (1.2.1), we obtain the equalities

$$C_+ p^{\gamma_+} + C_- p^{\gamma_-} = U(p) \quad \text{and} \quad C_+ q^{\gamma_+} + C_- q^{\gamma_-} = W(q) \quad (1.4.9)$$

which hold for some $0 < p < c < q < \infty$, where c is uniquely determined by the equation $U(c) = W(c)$. Solving the system of equations in (1.4.9), we obtain the function

$$V(s; p, q) = C_+(p, q) s^{\gamma_+} + C_-(p, q) s^{\gamma_-} \quad (1.4.10)$$

which satisfies the system in (1.4.3)-(1.4.4) with

$$C_+(p, q) = \frac{U(p)q^{\gamma_-} - W(q)p^{\gamma_-}}{p^{\gamma_+}q^{\gamma_-} - q^{\gamma_+}p^{\gamma_-}} \quad \text{and} \quad C_-(p, q) = \frac{W(q)p^{\gamma_+} - U(p)q^{\gamma_+}}{p^{\gamma_+}q^{\gamma_-} - q^{\gamma_+}p^{\gamma_-}} \quad (1.4.11)$$

for $0 < p < c < q < \infty$. Applying the smooth-fit conditions from (1.4.5) to the function in (1.4.10), we obtain the equalities

$$C_+(p, q) \gamma_+ p^{\gamma_+} + C_-(p, q) \gamma_- p^{\gamma_-} = pU'(p) \quad (1.4.12)$$

$$C_+(p, q) \gamma_+ q^{\gamma_+} + C_-(p, q) \gamma_- q^{\gamma_-} = qW'(q) \quad (1.4.13)$$

which hold with $C_+(p, q)$ and $C_-(p, q)$ given by (1.4.11). It is shown by means of standard arguments that the system in (1.4.12)-(1.4.13) is equivalent to

$$I_+(p) = J_+(q) \quad \text{and} \quad I_-(p) = J_-(q) \quad (1.4.14)$$

with

$$I_+(p) = \frac{pU'(p) - \gamma_- U(p)}{p^{\gamma_+}} \quad \text{and} \quad J_+(q) = \frac{qW'(q) - \gamma_- W(q)}{q^{\gamma_+}} \quad (1.4.15)$$

$$I_-(p) = \frac{\gamma_+ U(p) - pU'(p)}{p^{\gamma_-}} \quad \text{and} \quad J_-(q) = \frac{\gamma_+ W(q) - qW'(q)}{q^{\gamma_-}} \quad (1.4.16)$$

for all $0 < p < c < q < \infty$.

In order to show the existence and uniqueness of a solution of the system of equations in (1.4.14), we follow the schema of arguments from [47; Section 4] which are based on the idea of the proof of the existence and uniqueness of solutions applied to the systems of equations in (4.73)-(4.74) from [104; Chapter IV, Section 2] and (3.16)-(3.17) from [42; Section 3]. For this, we observe that, for the derivatives of the functions in (1.4.15)-(1.4.16), the expressions

$$I'_+(p) = -\frac{(\gamma_+ - 1)(\gamma_- - 1)p - \gamma_+\gamma_-L_2}{p^{\gamma_++1}} \equiv -\frac{(\gamma_+ - 1)(\gamma_- - 1)(p - \bar{L}_2)}{p^{\gamma_++1}} < 0 \quad (1.4.17)$$

$$J'_+(q) = \frac{(\gamma_+ - 1)(\gamma_- - 1)q - \gamma_+\gamma_-K_2}{q^{\gamma_++1}} \equiv \frac{(\gamma_+ - 1)(\gamma_- - 1)(q - \bar{K}_2)}{q^{\gamma_++1}} < 0 \quad (1.4.18)$$

$$I'_-(p) = \frac{(\gamma_+ - 1)(\gamma_- - 1)p - \gamma_+\gamma_-L_2}{p^{\gamma_-+1}} \equiv \frac{(\gamma_+ - 1)(\gamma_- - 1)(p - \bar{L}_2)}{p^{\gamma_-+1}} > 0 \quad (1.4.19)$$

$$J'_-(q) = -\frac{(\gamma_+ - 1)(\gamma_- - 1)q - \gamma_+\gamma_-K_2}{q^{\gamma_-+1}} \equiv -\frac{(\gamma_+ - 1)(\gamma_- - 1)(q - \bar{K}_2)}{q^{\gamma_-+1}} > 0 \quad (1.4.20)$$

hold under $0 < p < g_* < \bar{L}_2$ and $\bar{K}_2 < h_* < q < \infty$, and are equal to zero otherwise, where we set

$$\bar{L}_2 = \frac{\gamma_+\gamma_-L_2}{(\gamma_+ - 1)(\gamma_- - 1)} \equiv \frac{rL_2}{\delta} \quad \text{and} \quad \bar{K}_2 = \frac{\gamma_+\gamma_-K_2}{(\gamma_+ - 1)(\gamma_- - 1)} \equiv \frac{rK_2}{\delta}. \quad (1.4.21)$$

Hence, the function $I_+(p)$ decreases on the interval $(0, g_*)$ from $I_+(0+) = \infty$ to $I_+(g_*) = 0$, and then remains equal to zero on the interval (g_*, ∞) , so that the range of its values is given by the interval $(0, \infty)$. The function $J_+(q)$ is equal to $J_+(h_*) = (\gamma_+ - \gamma_-)h_*^{1-\gamma_+}/\gamma_+ > 0$ on the interval $(0, h_*)$, and then decreases to zero on the interval (h_*, ∞) , so that the range is $(0, J_+(h_*))$. The function $I_-(p)$ increases from zero to $I_-(g_*) = (\gamma_- - \gamma_+)g_*^{1-\gamma_-}/\gamma_- > 0$ on the interval $(0, g_*)$, and then remains equal to $I_-(g_*)$ on the interval (g_*, ∞) , so that the range is $(0, I_-(g_*))$. The function $J_-(q)$ is equal to zero on the interval $(0, h_*)$, and then increases from $J_-(h_*) = 0$ to infinity on the interval (h_*, ∞) , so that the range is $(0, \infty)$. It is shown by means of straightforward computations that $I_+(g_* \wedge c) < J_+(h_* \vee c)$ and $I_-(g_* \wedge c) > J_-(h_* \vee c)$ holds. This fact guarantees that the ranges of values of the left- and right-hand sides of the equations in (1.4.14) have nontrivial intersections.

It thus follows from the left-hand equation in (1.4.14) that, for each $q \in (h_* \vee c, \infty)$, there exists a unique number $p \in (\hat{p}, g_* \wedge c)$, where \hat{p} is uniquely determined by the equation $I_+(\hat{p}) = J_+(h_* \vee c)$. It also follows from the right-hand equation in (1.4.14) that, for each $p \in (0, g_* \wedge c)$, there exists a unique number $q \in (h_* \vee c, \hat{q})$, where \hat{q} is uniquely determined by the equation $I_-(g_* \wedge c) = J_-(\hat{q})$ (see Figure 7 below). We may therefore conclude that the equations in (1.4.14) uniquely define the function $q_+(p)$ on $(\hat{p}, g_* \wedge c)$ with the range $(h_* \vee c, \infty)$ and the function $q_-(p)$ on $(0, g_* \wedge c)$ with the range $(h_* \vee c, \hat{q})$, respectively. This fact directly yields that, for each point $p \in (\hat{p}, g_* \wedge c)$, there exist unique values $q_+(p)$ and $q_-(p)$ belonging to $(h_* \vee c, \infty)$,

that together with the inequalities $h_* \vee c \equiv q_+(\hat{p}) \equiv q_-(0+) < q_-(g_* \wedge c) < \infty \equiv q_+(g_*)$ guarantees the existence of exactly one intersection point with the coordinates p_* and q_* of the curves associated with the functions $q_+(p)$ and $q_-(p)$ on the interval $(\hat{p}, g_* \wedge c)$ such that $h_* \vee c < q_+(p_*) \equiv q_* \equiv q_-(p_*) < \hat{q}$ holds (see Figure 7 below). This completes the proof of the claim.

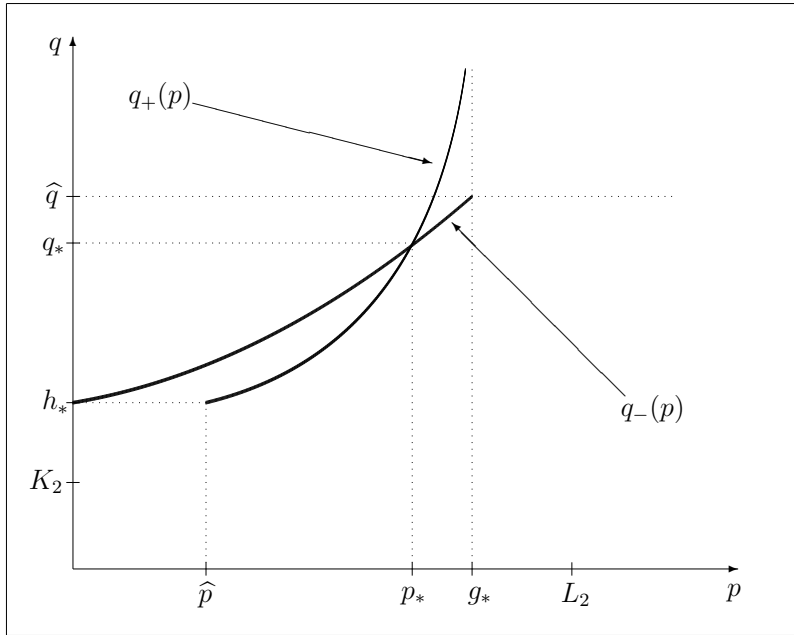

Figure 7. A computer drawing of the functions $q_+(p)$ and $q_-(p)$.

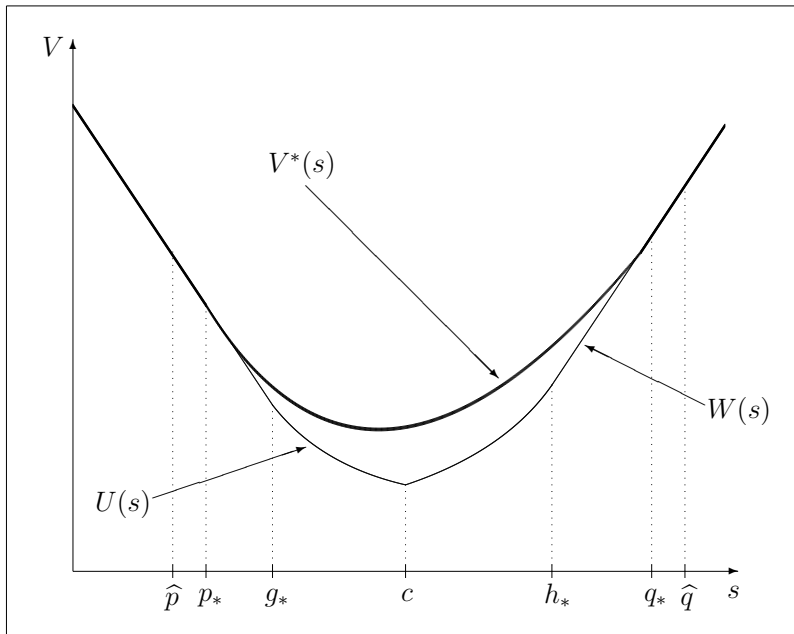

Figure 8. A computer drawing of the value function $V^*(s)$ for the case $g_* < c < h_*$ for the payoff function $U(s) \vee W(s)$.

Summarising the facts proved above, we are now ready to formulate the following result.

Proposition 1.4.1 *Let the process S be given by (1.1.1)-(1.1.2), the functions $U(s)$ and $W(s)$ be defined in (1.1.9)-(1.1.11), and the number c is uniquely determined by $U(c) = W(c)$. Hence, in the optimal stopping problem of (1.4.1), related to the perpetual American chooser option with the inner put and call payoffs with strike prices $L_2 > 0$ and $K_2 > 0$, respectively, the value function has the form*

$$V^*(s) = \begin{cases} V(s; p_*, q_*), & \text{if } p_* < s < q_* \\ U(s) \vee W(s), & \text{if } s \leq p_* \text{ or } s \geq q_* \end{cases} \quad (1.4.22)$$

where the function $V(s; p, q)$ is given by (1.4.10)-(1.4.11), and the exit boundaries p_* and q_* such that $0 < p_* < g_* \wedge c \leq h_* \vee c < q_* < \infty$ for the optimal exercise time τ^* in (1.4.2) are uniquely determined by the system of (1.4.14) (see Figure 8 above). The underlying perpetual American put or call option should then be exercised at the same time τ^* .

Proof of Proposition 1.4.1. In order to verify the assertion stated above, let us follow the schema of arguments from [47; Theorem 3.1] and show that the function defined in (1.4.22) coincides with the value function in (1.4.1), and that the stopping time τ^* in (1.4.2) is optimal with the boundaries p_* and q_* specified above. Let us denote by $V(s)$ the right-hand side of the expression in (1.4.22). Applying the local time-space formula from [91] and taking into account the smooth-fit conditions in (1.4.5), the following expression

$$e^{-rt} V(S_t) = V(s) + \int_0^t e^{-ru} (\mathbb{L}V - rV)(S_u) I(S_u \neq p_*, S_u \neq q_*) du + M_t^* \quad (1.4.23)$$

holds for all $t \geq 0$, where the process $M^* = (M_t^*)_{t \geq 0}$ defined by

$$M_t^* = \int_0^t e^{-ru} V'(S_u) \sigma S_u dB_u \quad (1.4.24)$$

is a continuous square integrable martingale with respect to P . The latter fact can be easily observed, since the derivative $V'(s)$ is a bounded function.

By means of straightforward computations, it can be verified that the conditions of (1.4.7) and (1.4.8) hold with p_* and q_* being a unique solution of the system in (1.4.14). These facts together with the conditions in (1.4.3)-(1.4.4) and (1.4.6) yield that $(\mathbb{L}V - rV)(s) \leq 0$ holds for any $s > 0$ such that $s \neq p_*$ and $s \neq q_*$, and $V(s) \geq U(s) \vee W(s)$ is satisfied for all $s > 0$. Moreover, since the time spent by the process S at the boundaries p_* and q_* is of Lebesgue measure zero, the indicator which appear in the integral of (1.4.23) can be ignored. Hence, it follows from the expression in (1.4.23) that the inequalities

$$e^{-r(\tau \wedge t)} (U(S_{\tau \wedge t}) \vee W(S_{\tau \wedge t})) \leq e^{-r(\tau \wedge t)} V(S_{\tau \wedge t}) \leq V(s) + M_{\tau \wedge t}^* \quad (1.4.25)$$

hold for any stopping time τ of the process S started at $s > 0$. Then, taking the expectations with respect to P in (1.4.25), by means of Doob's optional sampling theorem, we get that the inequalities

$$E[e^{-r(\tau \wedge t)} (U(S_{\tau \wedge t}) \vee W(S_{\tau \wedge t}))] \leq E[e^{-r(\tau \wedge t)} V(S_{\tau \wedge t})] \leq V(s) + E[M_{\tau \wedge t}^*] = V(s) \quad (1.4.26)$$

hold for all $s > 0$. Hence, letting t go to infinity and using Fatou's lemma, we obtain

$$E[e^{-r\tau} (U(S_\tau) \vee W(S_\tau))] \leq E[e^{-r\tau} V(S_\tau)] \leq V(s) \quad (1.4.27)$$

for any stopping time τ and all $s > 0$. By virtue of the structure of the stopping time in (1.4.2), it is readily seen that the equalities in (1.4.27) hold with τ^* instead of τ when either $s \leq p_*$ or $s \geq q_*$.

It remains to be shown that the equalities are attained in (1.4.27) when τ^* replaces τ for $p_* < s < q_*$. By virtue of the fact that the function $V(s; p_*, q_*)$ and the boundaries p_* and q_* satisfy the conditions in (1.4.3) and (1.4.4), it follows from the expression in (1.4.23) and the structure of the stopping time in (1.4.2) that the equality

$$e^{-r(\tau^* \wedge t)} V(S_{\tau^* \wedge t}; p_*, q_*) = V(s) + M_{\tau^* \wedge t}^* \quad (1.4.28)$$

is satisfied for all $s \in (p_*, q_*)$, where the process M^* is defined in (1.4.24). Observe that the explicit form of the function in (1.4.10) and (1.4.11) yields that the condition

$$E\left[\sup_{t \geq 0} e^{-r(\tau^* \wedge t)} V(S_{\tau^* \wedge t}; p_*, q_*)\right] < \infty \quad (1.4.29)$$

holds for all $s \in (p_*, q_*)$, as well as the variable $e^{-r\tau^*} V(S_{\tau^*}; p_*, q_*)$ is equal to zero on the event $\{\tau^* = \infty\}$ (P -a.s.). Hence, taking into account the property in (1.4.29), we conclude from the expression in (1.4.28) that the process $(M_{\tau^* \wedge t}^*)_{t \geq 0}$ is a uniformly integrable martingale. Therefore, taking the expectation in (1.4.28) and letting t go to infinity, we apply the Lebesgue dominated convergence theorem to obtain the equalities

$$E[e^{-r\tau^*} (U(S_{\tau^*}) \vee W(S_{\tau^*}))] = E[e^{-r\tau^*} V(S_{\tau^*}; p_*, q_*)] = V(s) \quad (1.4.30)$$

for all $s \in (p_*, q_*)$. The latter, together with the inequalities in (1.4.27), implies the fact that $V(s)$ coincides with the value function $V^*(s)$ from (1.4.1) and τ^* from (1.4.2) is the optimal stopping time. \square

Remark 1.4.2 Observe that the system of (1.4.14) is equivalent to the system of (4.5) from [47] with the only difference that the $(\widehat{p}, g_* \wedge c)$ and $(h_* \vee c, \widehat{q})$ are allowed for p_* and q_* , respectively, which are eventually smaller than the corresponding ones $(\bar{p}, g_* \wedge c)$ and $(h_* \vee c, \bar{q})$ from [47; Section 4]. Here, the numbers g_* and h_* are given by (1.1.13), and the boundaries $\bar{p} < \widehat{p}$ and

$\bar{q} > \hat{q}$ are uniquely determined by the equations $I_+(\bar{p}) = J_+(\bar{K}_2)$ and $I_-(\bar{L}_2) = J_-(\bar{q})$ with \bar{L}_2 and \bar{K}_2 defined in (1.4.21). It follows from the arguments above that the rational price $V^*(s)$ of the perpetual American chooser option in (1.4.1) coincides with the one of the perpetual American strangle option in [47; Example 4.2].

Chapter 2

Perpetual American options in a diffusion model with piecewise-linear coefficients

In this chapter (following [49]), we derive closed form solutions to the discounted optimal stopping problems related to the pricing of the perpetual American standard put and call options in an extension of the Black-Merton-Scholes model with piecewise-constant dividend and volatility rates. The method of proof is based on the reduction of the initial optimal stopping problems to the associated free-boundary problems and the subsequent martingale verification using a local time-space formula. We present explicit algorithms to determine the constant hitting thresholds for the underlying asset price process, which provide the optimal exercise boundaries for the options.

2.1. Preliminaries

In this section, we present the setting and notation of the perpetual American standard put and call option optimal stopping problems in a diffusion model with piecewise-linear coefficients. We also formulate the associated ordinary differential free-boundary problems.

2.1.1. Formulation of the problem. Let us consider a probability space (Ω, \mathcal{F}, P) carrying a standard one-dimensional Brownian motion $B = (B_t)_{t \geq 0}$. Assume that there exists a process $S = (S_t)_{t \geq 0}$ solving the stochastic differential equation

$$dS_t = (r - \Delta(S_t)) S_t dt + \Sigma(S_t) S_t dB_t \tag{2.1.1}$$

with $S_0 = s$, where the functions $\Delta(s)$ and $\Sigma(s)$ are defined by

$$\Delta(s) = \sum_{i=1}^n \delta_i I(L_{i-1} < s \leq L_i) \quad \text{and} \quad \Sigma(s) = \sum_{i=1}^n \sigma_i I(L_{i-1} < s \leq L_i) \quad (2.1.2)$$

for all $s > 0$ and some $0 = L_0 < L_1 < \dots < L_{n-1} < L_n = \infty$, $n \in \mathbb{N}$, fixed, and $I(\cdot)$ denotes the indicator function. Suppose that the process S describes the risk-neutral dynamics of the price of a risky asset (e.g. the value of an issuing firm) paying dividends. Here, $r > 0$ represents the riskless interest rate, $\sigma_i > 0$ is the volatility rate, and $\delta_i S$ such that $0 < \delta_i < r$ is the dividend rate paid to stockholders, whenever S fluctuates within the interval $(L_{i-1}, L_i]$, for every $i = 1, \dots, n$. Note that the stochastic differential equation in (2.1.1) admits a unique strong solution, and hence, S is a strong Markov process with respect to its natural filtration $(\mathcal{F}_t)_{t \geq 0}$ defined by $\mathcal{F}_t = \sigma(S_u \mid 0 \leq u \leq t)$, for all $t \geq 0$ (see, e.g. [110; Theorem 4], [69; Chapter 5] or [86; Chapter VII, Section 2]). A linear diffusion model with piecewise-constant coefficients was considered in [99].

The main purpose of this chapter is to compute the value functions of the optimal stopping problems

$$V^*(s) = \sup_{\tau} E_s [e^{-r\tau} (K_1 - S_{\tau}) \vee 0] \quad \text{or} \quad V^*(s) = \sup_{\tau} E_s [e^{-r\tau} (S_{\tau} - K_2) \vee 0] \quad (2.1.3)$$

where the suprema are taken over all stopping times τ with respect to the filtration $(\mathcal{F}_t)_{t \geq 0}$. Such values represent the rational (or no-arbitrage) prices of the perpetual American put and call options with strike prices $K_1, K_2 > 0$, respectively. Here, the expectations E_s are taken with respect to the equivalent martingale measure, under which the dynamics of S started at $s > 0$ are given by (2.1.1), and we further denote $x \vee y = \max\{x, y\}$ and $x \wedge y = \min\{x, y\}$, for any $x, y \in \mathbb{R}$. The left-hand problem of (2.1.3) was recently studied in [80] within the model of (2.1.1)-(2.1.2), under the assumption that $\Delta(s) = 0$.

2.1.2. Structure of the optimal stopping times. It follows from the general theory of optimal stopping for Markov processes (see, e.g. [97; Chapter I, Section 2]) that the optimal stopping times in the problems of (2.1.3) are given by

$$\tau^* = \inf\{t \geq 0 \mid V^*(S_t) = (K_1 - S_t) \vee 0\} \quad (2.1.4)$$

or

$$\tau^* = \inf\{t \geq 0 \mid V^*(S_t) = (S_t - K_2) \vee 0\} \quad (2.1.5)$$

whenever they exist. The latter fact means that the process S should be stopped at the first times at which it exits certain open intervals called the continuation regions. In this view, we further search for optimal stopping times of the problems of (2.1.3) in the form

$$\tau^* = \inf\{t \geq 0 \mid S_t \leq a^*\} \quad \text{or} \quad \tau^* = \inf\{t \geq 0 \mid S_t \geq b^*\} \quad (2.1.6)$$

for some $0 < a^* \leq K_1$ and $b^* \geq K_2$ to be determined. We also assume that the optimal stopping boundaries satisfy the conditions $L_{j-1} < a^* \leq L_j$ and $L_{m-1} < b^* \leq L_m$, for certain $j, m = 1, \dots, n$ to be specified.

2.1.3. The free-boundary problems. It can be shown by means of standard arguments (see, e.g. [69; Chapter V, Section 5.1] or [86; Chapter VII, Section 7.3]) that the infinitesimal operator \mathbb{L} of the process S acts on an arbitrary twice continuously differentiable function $F(s)$ on the intervals $(L_{i-1}, L_i]$ according to the rule

$$(\mathbb{L}F)(s) = (r - \delta_i) s F'(s) + \frac{\sigma_i^2}{2} s^2 F''(s) \quad \text{for } L_{i-1} < s \leq L_i \quad (2.1.7)$$

and we set $F'(L_i) = F'(L_i-)$ and $F''(L_i) = F''(L_i-)$, for every $i = 1, \dots, n$. In order to find explicit expressions for the unknown value functions $V^*(s)$ from (2.1.3) and the unknown boundaries a^* or b^* from (2.1.6), we may use the results of the general theory of optimal stopping problems for continuous time Markov processes (see, e.g. [97; Chapter IV, Section 8]). We formulate the associated free-boundary problems

$$(\mathbb{L}V)(s) = rV(s) \quad \text{for } s > a \quad \text{or } s < b \quad \text{and} \\ \text{such that } s \neq L_i, \quad i = j, \dots, m-1 \quad (2.1.8)$$

$$V(a+) = K_1 - a \quad \text{or } V(b-) = b - K_2 \quad (\text{instantaneous stopping}) \quad (2.1.9)$$

$$V'(a+) = -1 \quad \text{or } V'(b-) = 1 \quad (\text{smooth fit}) \quad (2.1.10)$$

$$V(s) = K_1 - s \quad \text{for } s < a \quad \text{or } V(s) = s - K_2 \quad \text{for } s > b \quad (2.1.11)$$

$$V(s) > (K_1 - s) \vee 0 \quad \text{for } s > a \quad \text{or } V(s) > (s - K_2) \vee 0 \quad \text{for } s < b \quad (2.1.12)$$

$$(\mathbb{L}V)(s) < rV(s) \quad \text{for } s < a \quad \text{or } s > b \quad (2.1.13)$$

for some $0 < a \leq K_1$ or $b \geq K_2$ fixed, in the case of put or call option, respectively. Here, the conditions of (2.1.9) and (2.1.10) are used to specify the solutions of the free-boundary problems which are related to the optimal stopping problems in (2.1.3).

2.2. Solution of the free-boundary problem

In this section, we derive solutions to the free-boundary problems formulated above for the cases of put and call option, separately, and prove the uniqueness of solutions of the related arithmetic equations for optimal stopping boundaries.

2.2.1. The equivalent system of arithmetic equations. We first note that the general solution of the second order ordinary differential equation in (2.1.8) is given by

$$V(s) = \sum_{i=1}^n \left(C_i^+ s^{\gamma_i^+} + C_i^- s^{\gamma_i^-} \right) I(L_{i-1} < s \leq L_i) \quad (2.2.1)$$

where C_i^+ and C_i^- are some arbitrary constants, and define

$$\gamma_i^\pm = \frac{1}{2} - \frac{r - \delta_i}{\sigma_i^2} \pm \sqrt{\left(\frac{1}{2} - \frac{r - \delta_i}{\sigma_i^2}\right)^2 + \frac{2r}{\sigma_i^2}} \quad (2.2.2)$$

so that $\gamma_i^- < 0 < 1 < \gamma_i^+$ holds for every $i = 1, \dots, n$. Hence, applying the instantaneous-stopping and smooth-fit conditions from (2.1.9)-(2.1.10) to the function in (2.2.1) and using the fact that the value function $V^*(s)$ is continuously differentiable for $s > a$ or $s < b$ in the case of put or call option, respectively, we get that the equalities

$$C_j^+ a^{\gamma_j^+} + C_j^- a^{\gamma_j^-} = K_1 - a \quad \text{or} \quad C_m^+ b^{\gamma_m^+} + C_m^- b^{\gamma_m^-} = b - K_2 \quad (2.2.3)$$

$$C_j^+ \gamma_j^+ a^{\gamma_j^+} + C_j^- \gamma_j^- a^{\gamma_j^-} = -a \quad \text{or} \quad C_m^+ \gamma_m^+ b^{\gamma_m^+} + C_m^- \gamma_m^- b^{\gamma_m^-} = b \quad (2.2.4)$$

$$C_{i-1}^+ L_{i-1}^{\gamma_{i-1}^+} + C_{i-1}^- L_{i-1}^{\gamma_{i-1}^-} = C_i^+ L_{i-1}^{\gamma_i^+} + C_i^- L_{i-1}^{\gamma_i^-} \quad (2.2.5)$$

$$C_{i-1}^+ \gamma_{i-1}^+ L_{i-1}^{\gamma_{i-1}^+} + C_{i-1}^- \gamma_{i-1}^- L_{i-1}^{\gamma_{i-1}^-} = C_i^+ \gamma_i^+ L_{i-1}^{\gamma_i^+} + C_i^- \gamma_i^- L_{i-1}^{\gamma_i^-} \quad (2.2.6)$$

hold for $i = j + 1, \dots, m$ and some $L_{j-1} < a \leq L_j \wedge K_1$ or $K_2 \vee L_{m-1} < b \leq L_m$. Observe that, in the case of the put option when the left hand side of (2.2.3)-(2.2.4) is realised, we have a unique optimal exercise boundary a^* given by the left-hand optimal stopping time in (2.1.6). It thus follows that $m = n$ for the equations in (2.2.5)-(2.2.6), while j is determined by the interval to which the point a^* belongs and there is no exercise boundary b involved. Similarly in the case of the call option, we have a unique optimal exercise boundary b^* , given by the right-hand optimal stopping time in (2.1.6). In this case, $j = 1$ for the equations in (2.2.5)-(2.2.6), while m is determined by the interval to which the point b^* belong and there is no exercise boundary a involved. It thus follows that the function

$$V(s; a, b) = \sum_{i=j}^m \left(C_i^+(a, b, L_j, \dots, L_{m-1}) s^{\gamma_i^+} + C_i^-(a, b, L_j, \dots, L_{m-1}) s^{\gamma_i^-} \right) I(L_{i-1} < s \leq L_i) \quad (2.2.7)$$

satisfies the system in (2.1.8)-(2.1.10) with some $C_i^+(a, b, L_j, \dots, L_{m-1})$ and $C_i^-(a, b, L_j, \dots, L_{m-1})$ to be specified by the system in (2.2.3)-(2.2.6), for some $L_{j-1} < a \leq L_j \wedge K_1$ or $K_2 \vee L_{m-1} < b \leq L_m$.

2.2.2. Solution for the case of put option. Observe that we should also have $C_n^+ = 0$ in (2.2.1) when the left-hand part of the system in (2.1.8)-(2.1.13) is realised with $m = n$, since otherwise $V(s) \rightarrow \pm\infty$, that must be excluded by virtue of the obvious fact that the value function in (2.1.3) is bounded under $s \uparrow \infty$. In this case, solving the system of equations in the left-hand part of (2.2.3)-(2.2.4), we get that its solution is given by

$$C_j^+(a) = \frac{I_j^+(a)}{\gamma_j^+ - \gamma_j^-} \quad \text{and} \quad C_j^-(a) = \frac{I_j^-(a)}{\gamma_j^+ - \gamma_j^-} \quad (2.2.8)$$

with

$$I_j^+(a) = \frac{(\gamma_j^- - 1)a - \gamma_j^- K_1}{a^{\gamma_j^+}} \quad \text{and} \quad I_j^-(a) = \frac{(1 - \gamma_j^+)a + \gamma_j^+ K_1}{a^{\gamma_j^-}} \quad (2.2.9)$$

for all $L_{j-1} < a \leq L_j \wedge K_1$.

Then, solving the system of equations in (2.2.5)-(2.2.6), we get the recursive expressions

$$\begin{aligned} C_i^+ L_i^{\gamma_i^+} &\equiv C_i^+ L_{i-1}^{\gamma_{i-1}^+} \left(\frac{L_i}{L_{i-1}} \right)^{\gamma_i^+} \\ &= \left[C_{i-1}^+ L_{i-1}^{\gamma_{i-1}^+} \frac{\gamma_{i-1}^+ - \gamma_i^-}{\gamma_i^+ - \gamma_i^-} + C_{i-1}^- L_{i-1}^{\gamma_{i-1}^-} \frac{\gamma_{i-1}^- - \gamma_i^-}{\gamma_i^+ - \gamma_i^-} \right] \left(\frac{L_i}{L_{i-1}} \right)^{\gamma_i^+} \end{aligned} \quad (2.2.10)$$

and

$$\begin{aligned} C_i^- L_i^{\gamma_i^-} &\equiv C_i^- L_{i-1}^{\gamma_{i-1}^-} \left(\frac{L_i}{L_{i-1}} \right)^{\gamma_i^-} \\ &= \left[C_{i-1}^+ L_{i-1}^{\gamma_{i-1}^+} \frac{\gamma_i^+ - \gamma_{i-1}^+}{\gamma_i^+ - \gamma_i^-} + C_{i-1}^- L_{i-1}^{\gamma_{i-1}^-} \frac{\gamma_i^+ - \gamma_{i-1}^-}{\gamma_i^+ - \gamma_i^-} \right] \left(\frac{L_i}{L_{i-1}} \right)^{\gamma_i^-} \end{aligned} \quad (2.2.11)$$

for any $i = j + 1, \dots, n - 1$. Hence, using the expressions in (2.2.8), we obtain that the expressions

$$C_i^+ = \frac{\text{sgn}(\gamma_i^+)}{\gamma_i^+ - \gamma_i^-} \sum I_j^{\pm}(a) \frac{L_j^{\gamma_j^{\pm}}}{L_{i-1}^{\gamma_{i-1}^{\pm}}} \frac{\gamma_{i-1}^{\pm} - \gamma_i^-}{\gamma_i^+ - \gamma_{i-1}^-} \prod_{k=j+1}^{i-1} \text{sgn}(\gamma_k^{\pm}) \frac{\gamma_{k-1}^{\pm} - \gamma_k^{\mp}}{\gamma_{k-1}^+ - \gamma_{k-1}^-} \left(\frac{L_k}{L_{k-1}} \right)^{\gamma_k^{\pm}} \quad (2.2.12)$$

and

$$C_i^- = \frac{\text{sgn}(\gamma_i^-)}{\gamma_i^+ - \gamma_i^-} \sum I_j^{\pm}(a) \frac{L_j^{\gamma_j^{\pm}}}{L_{i-1}^{\gamma_{i-1}^{\pm}}} \frac{\gamma_{i-1}^{\pm} - \gamma_i^+}{\gamma_i^+ - \gamma_{i-1}^-} \prod_{k=j+1}^{i-1} \text{sgn}(\gamma_k^{\pm}) \frac{\gamma_{k-1}^{\pm} - \gamma_k^{\mp}}{\gamma_{k-1}^+ - \gamma_{k-1}^-} \left(\frac{L_k}{L_{k-1}} \right)^{\gamma_k^{\pm}} \quad (2.2.13)$$

hold for any $i = j + 1, \dots, n - 1$, while using the equalities in (2.2.12)-(2.2.13), we also get from (2.2.5) that the expression

$$C_n^- = \frac{1}{\gamma_{n-1}^+ - \gamma_{n-1}^-} \sum I_j^{\pm}(a) \frac{L_j^{\gamma_j^{\pm}}}{L_{n-1}^{\gamma_{n-1}^{\pm}}} \prod_{i=j+1}^{n-1} \text{sgn}(\gamma_i^{\pm}) \frac{\gamma_{i-1}^{\pm} - \gamma_i^{\mp}}{\gamma_{i-1}^+ - \gamma_{i-1}^-} \left(\frac{L_i}{L_{i-1}} \right)^{\gamma_i^{\pm}} \quad (2.2.14)$$

holds. The sums in (2.2.12)-(2.2.14) as well as in (2.2.18)-(2.2.19) below should be read accord-

ing to the rule

$$\begin{aligned}
& \sum G(I_j^\pm(a), \gamma_j^\pm, \gamma_j^\mp, \gamma_{j+1}^\pm, \gamma_{j+1}^\mp, \dots, \gamma_n^\pm, \gamma_n^\mp) \\
& \equiv G(I_j^+(a), \gamma_j^+, \gamma_j^-, \gamma_{j+1}^+, \gamma_{j+1}^-, \dots, \gamma_n^+, \gamma_n^-) \\
& \quad + G(I_j^-(a), \gamma_j^-, \gamma_j^+, \gamma_{j+1}^-, \gamma_{j+1}^+, \dots, \gamma_n^-, \gamma_n^+) \\
& \quad + G(I_j^+(a), \gamma_j^+, \gamma_j^-, \gamma_{j+1}^+, \gamma_{j+1}^-, \dots, \gamma_n^+, \gamma_n^-) \\
& \quad + G(I_j^-(a), \gamma_j^-, \gamma_j^+, \gamma_{j+1}^-, \gamma_{j+1}^+, \dots, \gamma_n^-, \gamma_n^+) + \dots \\
& \quad + G(I_j^+(a), \gamma_j^+, \gamma_j^-, \gamma_{j+1}^+, \gamma_{j+1}^-, \dots, \gamma_n^-, \gamma_n^+) \\
& \quad + G(I_j^-(a), \gamma_j^-, \gamma_j^+, \gamma_{j+1}^-, \gamma_{j+1}^+, \dots, \gamma_n^-, \gamma_n^+) \\
& \quad + G(I_j^+(a), \gamma_j^+, \gamma_j^-, \gamma_{j+1}^+, \gamma_{j+1}^-, \dots, \gamma_n^-, \gamma_n^+) \\
& \quad + G(I_j^-(a), \gamma_j^-, \gamma_j^+, \gamma_{j+1}^-, \gamma_{j+1}^+, \dots, \gamma_n^-, \gamma_n^+)
\end{aligned} \tag{2.2.15}$$

for any measurable function $G(I_j^\pm(a), \gamma_j^\pm, \gamma_j^\mp, \gamma_{j+1}^\pm, \gamma_{j+1}^\mp, \dots, \gamma_n^\pm, \gamma_n^\mp)$. Thus, taking into account the fact that $C_n^+ = 0$, we obtain from the system in (2.2.5)-(2.2.6) that the equality

$$C_{n-1}^+ (\gamma_n^- - \gamma_{n-1}^+) L_{n-1}^{\gamma_{n-1}^+} = C_{n-1}^- (\gamma_{n-1}^- - \gamma_n^-) L_{n-1}^{\gamma_{n-1}^-} \tag{2.2.16}$$

is satisfied. Using the expressions in (2.2.12)-(2.2.13), we can therefore conclude that the equation in (2.2.16) takes the form

$$I_j^+(a) L_j^{\gamma_j^+} Q_j^+ = I_j^-(a) L_j^{\gamma_j^-} Q_j^- \tag{2.2.17}$$

for $L_{j-1} < a \leq L_j \wedge K_1$, with

$$Q_j^+ = \text{sgn}(\gamma_j^+) \sum \frac{(\gamma_j^+ - \gamma_{j+1}^\mp)(\gamma_{n-1}^\pm - \gamma_n^-)}{\gamma_{n-1}^\pm - \gamma_n^\mp} \prod_{i=j+1}^{n-1} \text{sgn}(\gamma_i^\pm)(\gamma_i^\pm - \gamma_{i+1}^\mp) \left(\frac{L_i}{L_{i-1}}\right)^{\gamma_i^\pm} \tag{2.2.18}$$

and

$$Q_j^- = \text{sgn}(\gamma_j^-) \sum \frac{(\gamma_j^- - \gamma_{j+1}^\mp)(\gamma_{n-1}^\pm - \gamma_n^-)}{\gamma_{n-1}^\pm - \gamma_n^\mp} \prod_{i=j+1}^{n-1} \text{sgn}(\gamma_i^\pm)(\gamma_i^\pm - \gamma_{i+1}^\mp) \left(\frac{L_i}{L_{i-1}}\right)^{\gamma_i^\pm} \tag{2.2.19}$$

for every $j = 1, \dots, n-2$, while $Q_{n-1}^+ = \gamma_{n-1}^+ - \gamma_n^-$, $Q_{n-1}^- = \gamma_n^- - \gamma_{n-1}^-$, $Q_n^+ = \gamma_n^+ - \gamma_n^-$, and $Q_n^- = 0$.

In order to prove the uniqueness of solution of the equation in (2.2.17), we observe that the derivatives of the functions in (2.2.9) are given by the expressions

$$I_j^{+'}(a) = \frac{(\gamma_j^+ - 1)(\gamma_j^- - 1)(\overline{K}_{1,j} - a)}{a^{\gamma_j^+ + 1}} \quad \text{and} \quad I_j^{-'}(a) = \frac{(\gamma_j^+ - 1)(\gamma_j^- - 1)(a - \overline{K}_{1,j})}{a^{\gamma_j^- + 1}} \tag{2.2.20}$$

so that $I_j^+(a) < 0$ and $I_j^-(a) > 0$ for all $0 < L_{j-1} < a \leq L_j \wedge K_1 < \overline{K}_{1,j}$, with

$$\overline{K}_{1,j} = \frac{\gamma_j^+ \gamma_j^- K_1}{(\gamma_j^+ - 1)(\gamma_j^- - 1)} \equiv \frac{rK_1}{\delta_j} > K_1 \quad (2.2.21)$$

so that the function $I_j^+(a)$ decreases and the function $I_j^-(a)$ increases on the interval $(L_{j-1}, L_j \wedge K_1]$. Hence, the equation in (2.2.17) admits a unique solution if and only if the inequalities

$$\frac{I_j^+(L_{j-1})L_j^{\gamma_j^+}}{Q_j^-} > \frac{I_j^-(L_{j-1})L_j^{\gamma_j^-}}{Q_j^+} \quad \text{and} \quad \frac{I_j^+(L_j \wedge K_1)L_j^{\gamma_j^+}}{Q_j^-} \leq \frac{I_j^-(L_j \wedge K_1)L_j^{\gamma_j^-}}{Q_j^+} \quad (2.2.22)$$

hold with Q_j^+ and Q_j^- given by the expressions in (2.2.18)-(2.2.19).

In order to prove the inequalities in (2.2.22) above, we first assume that $L_{j-1} < L_j < K_1$ holds. Then, it can be verified by means of the induction principle that the inequalities $Q_j^+ > 0$, $\gamma_j^+ Q_j^- < -\gamma_j^- Q_j^+$ and $\gamma_j^+ Q_j^- (L_{j-1})^{\gamma_j^+ - \gamma_j^-} < -\gamma_j^- Q_j^+ (L_j)^{\gamma_j^+ - \gamma_j^-}$ are satisfied for every $j = 1, \dots, n$. Hence, it is shown using straightforward computations that there exists a unique solution a_j^* of the equation in (2.2.17) such that $L_{j-1} < a_j^* \leq L_j$ if and only if the relationship $\mu_{j-1}L_{j-1} \vee L_j < K_1 \leq \mu_j L_j$ holds with

$$\mu_j = \frac{(\gamma_j^+ - 1) Q_j^- + (\gamma_j^- - 1) Q_j^+}{\gamma_j^+ Q_j^- + \gamma_j^- Q_j^+} > 1 \quad (2.2.23)$$

for every $j = 1, \dots, n$, and Q_j^+ and Q_j^- given by (2.2.18)-(2.2.19). Thus, the assumption $L_{j-1} < a_j^* \leq L_j$ can equivalently be replaced by the property $\mu_{j-1}L_{j-1} \vee L_j < K_1 \leq \mu_j L_j$. Observe that the latter inequalities can hold for K_1 if either $\mu_{j-1}L_{j-1} \leq L_j$, or $L_{j-1} < L_j < \mu_{j-1}L_{j-1}$ when $Q_j^- \geq 0$, or $L_{j-1} < \mu_{j-1}L_{j-1}/\mu_j < L_j < \mu_{j-1}L_{j-1}$ when $Q_j^- < 0$. Note that the property $\mu_{j-1}L_{j-1} \vee L_j < K_1 \leq \mu_j L_j$ does not hold, when $L_{j-1} < L_j \leq \mu_{j-1}L_{j-1}/\mu_j < \mu_{j-1}L_{j-1}$ and $Q_j^- < 0$, in which case there is no solution a_j^* of the equation in (2.2.17) in the interval $(L_{j-1}, L_j]$.

Let us now assume that $L_{j-1} < K_1 \leq L_j$ holds. In this case, it can be checked by means of the induction principle that the inequality $-Q_j^- < Q_j^+$ is satisfied for every $j = 1, \dots, n$. Hence, it is shown by means of straightforward computations and using the relationships between Q_j^+ and Q_j^- referred above that the equation in (2.2.17) admits a unique solution a_j^* such that $L_{j-1} < a_j^* \leq K_1$ if and only if the relationship $\mu_{j-1}L_{j-1} < K_1 \leq L_j$ holds with μ_j given by (2.2.23). Thus, the assumption $L_{j-1} < a_j^* \leq K_1$ can equivalently be replaced by the property $\mu_{j-1}L_{j-1} < K_1 \leq L_j$. Note that when the latter inequalities fail to hold, there is no solution a_j^* of the equation in (2.2.17) in the interval $(L_{j-1}, K_1]$.

Summarising the facts proved above, we can therefore formulate the following algorithm to specify the location interval $(L_{j-1}, L_j]$ for the solution a^* of the equation in (2.2.17), based on the corresponding relationships between K_1 , L_i and μ_j for $i, j = 1, \dots, n$ referred above.

Without loss of generality, let us thus assume that the strike price satisfies $L_{k-1} < K_1 \leq L_k$ for some $1 \leq k \leq n$, so that there exist k possible intervals in which the solution a^* can be located. Note that, after finding a solution $L_{j-1} < a_j^* \leq L_j$ of the equation in (2.2.17) for some $j = 1, \dots, k-2$, we can get another solution $L_{i-1} < a_i^* \leq L_i$, if $\mu_l L_l < \mu_{l-1} L_{l-1}$ holds for some $l = j+1, \dots, k-1$ and $l < i$. We further denote by a^* the minimum over such solutions a_j^* , $j = 1, \dots, k$, whenever they exist, and construct the corresponding solution $V(s; a^*)$ of the form in (2.2.7), which will dominate the other possible solutions of the second-order ordinary differential equation in (2.1.8), satisfying the conditions in (2.1.9)-(2.1.10) with the boundaries a_j^* , $j = 1, \dots, k$. The latter fact can be shown by means of the arguments similar to the ones used in [97; Chapter VI, Remark 23.2] and [97; Chapter VI, Theorem 24.1], or by verifying directly.

We can therefore start the following forward procedure started with $j = 1$, so that the value function associated with the solution $L_{j-1} < a_j^* \leq L_j \wedge K_1$ of the equation in (2.2.17), which is obtained first for a certain $j = 1, \dots, k$, dominates all the forthcoming possible solutions. Hence, the possibility of having other solutions $L_{i-1} < a_i^* \leq L_i$ for some $i > j+1$, does not make any impact on the procedure described below:

- (1) (searching for a solution in the interval $(L_0, L_1]$):
 - (a) if $K_1 \leq \mu_1 L_1$ holds, then there exists a solution $0 = L_0 < a_1^* \leq L_1$ of the equation in (2.2.17) for $j = 1$ and the optimal stopping boundary is given by $a^* = a_1^*$,
 - (b) if $\mu_1 L_1 < K_1$ holds, then continue with step (2);
- ⋮
- (j) (searching for a solution in the interval $(L_{j-1}, L_j]$, for $j = 2, \dots, k-1$):
 - (a) if $K_1 \leq \mu_j L_j$ holds, then there exists a solution $L_{j-1} < a_j^* \leq L_j$ of the equation in (2.2.17) and the optimal stopping boundary is given by $a^* = a_j^*$,
 - (b) if $\mu_j L_j < K_1$ holds, then continue with step (j+1);
- ⋮
- (k) (searching for a solution in the interval $(L_{k-1}, K_1]$):
 - in this case, $K_1 \leq L_k$ holds by assumption, and thus, there exists a solution $L_{k-1} < a_k^* \leq K_1$ of the equation in (2.2.17) for $j = k$ and the optimal stopping boundary is given by $a^* = a_k^*$.

Note that the above algorithm establishes the existence of at least one solution $L_{j-1} < a_j^* \leq L_j \wedge K_1$ of the equation in (2.2.17) for a certain $j = 1, \dots, k$, which coincides with the optimal stopping boundary a^* .

2.2.3. Solution for the case of call option. Observe that we should also have $C_1^- = 0$ in (2.2.1) when the right-hand part of the system in (2.1.8)-(2.1.13) is realised with $j = 1$,

since $V(s) \rightarrow \pm\infty$ otherwise, that must be excluded by virtue of the obvious fact that the value function in (2.1.3) is bounded under $s \downarrow 0$. In this case, solving the system of equations in the right-hand part of (2.2.3)-(2.2.4), we get that its solution is given by

$$C_m^+(b) = \frac{J_m^+(b)}{\gamma_m^+ - \gamma_m^-} \quad \text{and} \quad C_m^-(b) = \frac{J_m^-(b)}{\gamma_m^+ - \gamma_m^-} \quad (2.2.24)$$

with

$$J_m^+(b) = \frac{(1 - \gamma_m^-)b + \gamma_m^- K_2}{b\gamma_m^+} \quad \text{and} \quad J_m^-(b) = \frac{(\gamma_m^+ - 1)b - \gamma_m^+ K_2}{b\gamma_m^-} \quad (2.2.25)$$

for all $K_2 \vee L_{m-1} < b \leq L_m$. Then, solving the system of equations in (2.2.5)-(2.2.6), we obtain the recursive expressions

$$\begin{aligned} C_i^+ L_{i-1}^{\gamma_i^+} &\equiv C_i^+ L_i^{\gamma_i^+} \left(\frac{L_{i-1}}{L_i} \right)^{\gamma_i^+} \\ &= \left[C_{i+1}^+ L_i^{\gamma_{i+1}^+} \frac{\gamma_{i+1}^+ - \gamma_i^-}{\gamma_i^+ - \gamma_i^-} + C_{i+1}^- L_i^{\gamma_{i+1}^-} \frac{\gamma_{i+1}^- - \gamma_i^-}{\gamma_i^+ - \gamma_i^-} \right] \left(\frac{L_{i-1}}{L_i} \right)^{\gamma_i^+} \end{aligned} \quad (2.2.26)$$

and

$$\begin{aligned} C_i^- L_{i-1}^{\gamma_i^-} &\equiv C_i^- L_i^{\gamma_i^-} \left(\frac{L_{i-1}}{L_i} \right)^{\gamma_i^-} \\ &= \left[C_{i+1}^+ L_i^{\gamma_{i+1}^+} \frac{\gamma_i^+ - \gamma_{i+1}^+}{\gamma_i^+ - \gamma_i^-} + C_{i+1}^- L_i^{\gamma_{i+1}^-} \frac{\gamma_i^+ - \gamma_{i+1}^-}{\gamma_i^+ - \gamma_i^-} \right] \left(\frac{L_{i-1}}{L_i} \right)^{\gamma_i^-} \end{aligned} \quad (2.2.27)$$

for any $i = 2, \dots, m-1$. Hence, using the expressions in (2.2.24), we obtain that the expressions

$$C_i^+ = \frac{\text{sgn}(\gamma_i^+)}{\gamma_i^+ - \gamma_i^-} \sum J_m^\pm(b) \frac{L_{m-1}^{\gamma_m^\pm}}{L_i^{\gamma_i^+}} \frac{\gamma_{i+1}^\pm - \gamma_i^-}{\gamma_{i+1}^+ - \gamma_{i+1}^-} \prod_{k=i+1}^{m-1} \text{sgn}(\gamma_k^\pm) \frac{\gamma_{k+1}^\pm - \gamma_k^\mp}{\gamma_{k+1}^+ - \gamma_{k+1}^-} \left(\frac{L_{k-1}}{L_k} \right)^{\gamma_k^\pm} \quad (2.2.28)$$

and

$$C_i^- = \frac{\text{sgn}(\gamma_i^-)}{\gamma_i^+ - \gamma_i^-} \sum J_m^\pm(b) \frac{L_{m-1}^{\gamma_m^\pm}}{L_i^{\gamma_i^-}} \frac{\gamma_{i+1}^\pm - \gamma_i^+}{\gamma_{i+1}^+ - \gamma_{i+1}^-} \prod_{k=i+1}^{m-1} \text{sgn}(\gamma_k^\pm) \frac{\gamma_{k+1}^\pm - \gamma_k^\mp}{\gamma_{k+1}^+ - \gamma_{k+1}^-} \left(\frac{L_{k-1}}{L_k} \right)^{\gamma_k^\pm} \quad (2.2.29)$$

hold for any $i = 2, \dots, m-1$, while using the equalities in (2.2.28)-(2.2.29), we also get from (2.2.5) that the expression

$$C_1^+ = \frac{1}{\gamma_2^+ - \gamma_2^-} \sum J_m^\pm(b) \frac{L_{m-1}^{\gamma_m^\pm}}{L_1^{\gamma_1^+}} \prod_{i=2}^{m-1} \text{sgn}(\gamma_i^\pm) \frac{\gamma_{i+1}^\pm - \gamma_i^\mp}{\gamma_{i+1}^+ - \gamma_{i+1}^-} \left(\frac{L_{i-1}}{L_i} \right)^{\gamma_i^\pm} \quad (2.2.30)$$

holds. The sums in (2.2.28)-(2.2.30) as well as in (2.2.34)-(2.2.35) below should be read accord-

ing to the rule

$$\begin{aligned}
& \sum H(J_m^\pm(b), \gamma_m^\pm, \gamma_m^\mp, \gamma_{m-1}^\pm, \gamma_{m-1}^\mp, \dots, \gamma_1^\pm, \gamma_1^\mp) \\
& \equiv H(J_m^+(b), \gamma_m^+, \gamma_m^-, \gamma_{m-1}^+, \gamma_{m-1}^-, \dots, \gamma_1^+, \gamma_1^-) \\
& \quad + H(J_m^-(b), \gamma_m^-, \gamma_m^+, \gamma_{m-1}^-, \gamma_{m-1}^+, \dots, \gamma_1^-, \gamma_1^+) \\
& \quad + H(J_m^+(b), \gamma_m^+, \gamma_m^-, \gamma_{m-1}^-, \gamma_{m-1}^+, \dots, \gamma_1^+, \gamma_1^-) \\
& \quad + H(J_m^-(b), \gamma_m^-, \gamma_m^+, \gamma_{m-1}^+, \gamma_{m-1}^-, \dots, \gamma_1^-, \gamma_1^+) + \dots \\
& \quad + H(J_m^+(b), \gamma_m^+, \gamma_m^-, \gamma_{m-1}^+, \gamma_{m-1}^-, \dots, \gamma_1^+, \gamma_1^-) \\
& \quad + H(J_m^-(b), \gamma_m^-, \gamma_m^+, \gamma_{m-1}^+, \gamma_{m-1}^-, \dots, \gamma_1^-, \gamma_1^+) \\
& \quad + H(J_m^+(b), \gamma_m^+, \gamma_m^-, \gamma_{m-1}^-, \gamma_{m-1}^+, \dots, \gamma_1^+, \gamma_1^-) \\
& \quad + H(J_m^-(b), \gamma_m^-, \gamma_m^+, \gamma_{m-1}^-, \gamma_{m-1}^+, \dots, \gamma_1^-, \gamma_1^+)
\end{aligned} \tag{2.2.31}$$

for any measurable function $H(J_m^\pm(b), \gamma_m^\pm, \gamma_m^\mp, \gamma_{m-1}^\pm, \gamma_{m-1}^\mp, \dots, \gamma_1^\pm, \gamma_1^\mp)$. Thus, taking into account the fact that $C_1^- = 0$, we obtain from the system in (2.2.5)-(2.2.6) that the equality

$$C_2^+(\gamma_1^+ - \gamma_2^+)L_1^{\gamma_2^+} = C_2^-(\gamma_2^- - \gamma_1^+)L_1^{\gamma_2^-} \tag{2.2.32}$$

is satisfied. Using the expressions in (2.2.28)-(2.2.29), we can therefore conclude that the equation in (2.2.32) takes the form

$$J_m^+(b) L_{m-1}^{\gamma_m^+} R_m^+ = J_m^-(b) L_{m-1}^{\gamma_m^-} R_m^- \tag{2.2.33}$$

for $K_2 \vee L_{m-1} < b \leq L_m$, with

$$R_m^+ = \operatorname{sgn}(\gamma_m^+) \sum \frac{(\gamma_m^+ - \gamma_{m-1}^\mp)(\gamma_2^\pm - \gamma_1^+)}{\gamma_2^\pm - \gamma_1^\mp} \prod_{i=2}^{m-1} \operatorname{sgn}(\gamma_i^\pm)(\gamma_i^\pm - \gamma_{i-1}^\mp) \left(\frac{L_{i-1}}{L_i}\right)^{\gamma_i^\pm} \tag{2.2.34}$$

and

$$R_m^- = \operatorname{sgn}(\gamma_m^-) \sum \frac{(\gamma_m^- - \gamma_{m-1}^\mp)(\gamma_2^\pm - \gamma_1^+)}{\gamma_2^\pm - \gamma_1^\mp} \prod_{i=2}^{m-1} \operatorname{sgn}(\gamma_i^\pm)(\gamma_i^\pm - \gamma_{i-1}^\mp) \left(\frac{L_{i-1}}{L_i}\right)^{\gamma_i^\pm} \tag{2.2.35}$$

for every $m = 3, \dots, n$, while $R_2^- = \gamma_1^+ - \gamma_2^-$, $R_2^+ = \gamma_2^+ - \gamma_1^+$, $R_1^- = \gamma_1^+ - \gamma_1^-$, and $R_1^+ = 0$.

In order to prove the uniqueness of solution of the equation in (2.2.33), we observe that the derivatives of the functions in (2.2.25) are given by the expressions

$$J_m^{+'}(b) = \frac{(\gamma_m^+ - 1)(\gamma_m^- - 1)(b - \bar{K}_2)}{b^{\gamma_m^+ + 1}} \quad \text{and} \quad J_m^{-'}(b) = \frac{(\gamma_m^+ - 1)(\gamma_m^- - 1)(\bar{K}_2 - b)}{b^{\gamma_m^- + 1}} \tag{2.2.36}$$

so that $J_m^{+'}(b) < 0$ and $J_m^{-'}(b) > 0$ for all $0 < \bar{K}_{2,m} \vee L_{m-1} < b \leq L_m$, with

$$\bar{K}_{2,m} = \frac{\gamma_m^+ \gamma_m^- K_2}{(\gamma_m^+ - 1)(\gamma_m^- - 1)} \equiv \frac{r K_2}{\delta_m} > K_2 \tag{2.2.37}$$

so that the function $J_m^+(b)$ decreases and the function $J_m^-(b)$ increases on the interval $(\overline{K}_{2,m} \vee L_{m-1}, L_m]$. Hence, the equation in (2.2.33) admits a unique solution if and only if the inequalities

$$\frac{J_m^+(\overline{K}_{2,m} \vee L_{m-1})L_{m-1}^{\gamma_m^+}}{R_m^-} > \frac{J_m^-(\overline{K}_{2,m} \vee L_{m-1})L_{m-1}^{\gamma_m^-}}{R_m^+} \quad (2.2.38)$$

and

$$\frac{J_m^+(L_m)L_{m-1}^{\gamma_m^+}}{R_m^-} \leq \frac{J_m^-(L_m)L_{m-1}^{\gamma_m^-}}{R_m^+} \quad (2.2.39)$$

hold with R_m^+ and R_m^- given by the expressions in (2.2.34)-(2.2.35).

In order to prove the inequalities in (2.2.38)-(2.2.39) above, we first assume that $\overline{K}_{2,m} \leq L_{m-1} < L_m$ holds. Then, it can be verified by means of the induction principle that the inequalities $R_m^- > 0$, $\gamma_m^+ R_m^- > -\gamma_m^- R_m^+$ and $\gamma_m^+ R_m^-(L_m)^{\gamma_m^+ - \gamma_m^-} > -\gamma_m^- R_m^+(L_{m-1})^{\gamma_m^+ - \gamma_m^-}$ are satisfied for every $m = 1, \dots, n$. Hence, it is shown using straightforward computations that there exists a unique solution b_m^* of the equation in (2.2.33) such that $L_{m-1} < b_m^* \leq L_m$ if and only if the relationship $\lambda_m L_{m-1} < K_2 \leq \lambda_{m+1} L_m \wedge \delta_m L_{m-1}/r$ holds with

$$\lambda_m = \frac{(\gamma_m^+ - 1) R_m^- + (\gamma_m^- - 1) R_m^+}{\gamma_m^+ R_m^- + \gamma_m^- R_m^+} < 1 \quad (2.2.40)$$

for every $m = 1, \dots, n$, with R_m^+ and R_m^- given by (2.2.34)-(2.2.35). Thus, the assumption $L_{m-1} < b_m^* \leq L_m$ can equivalently be replaced by the property $\lambda_m L_{m-1} < K_2 \leq \lambda_{m+1} L_m \wedge \delta_m L_{m-1}/r$. Observe that the latter inequalities can hold for K_2 if either $L_m \leq \delta_m L_{m-1}/(\lambda_{m+1} r)$ when $\xi_m \leq 0$, or $\lambda_m L_{m-1}/\lambda_{m+1} < L_m \leq \delta_m L_{m-1}/(\lambda_{m+1} r)$ when $0 < \xi_m < 1$, or $\delta_m L_{m-1}/(\lambda_{m+1} r) < L_m$ when $\xi_m < 1$, where ξ_m is given by

$$\xi_m = -\frac{\gamma_m^-(\gamma_m^- - 1)R_m^+}{\gamma_m^+(\gamma_m^+ - 1)R_m^-} \quad (2.2.41)$$

for every $m = 1, \dots, n$. However, the property $\lambda_m L_{m-1} < K_2 \leq \lambda_{m+1} L_m \wedge \delta_m L_{m-1}/r$ does not hold when either $L_{m-1} < L_m \leq \lambda_m L_{m-1}/\lambda_{m+1}$ and $0 < \xi_m < 1$, or $\xi_m \geq 1$ holds, therefore there is no solution b_m^* of the equation in (2.2.33) in the interval $(L_{m-1}, L_m]$.

Let us now assume that $L_{m-1} < \overline{K}_{2,m} < L_m$ holds. In this case, it is shown by means of straightforward computations and using the relationships between R_m^+ and R_m^- referred above that the equation in (2.2.33) admits a unique solution b_m^* such that $\overline{K}_{2,m} < b_m^* \leq L_m$ if and only if the relationship

$$\frac{\delta_m L_{m-1}}{r} \vee \frac{\delta_m \nu_m L_{m-1}}{r} < K_2 \leq \lambda_{m+1} L_m \wedge \frac{\delta_m L_m}{r} \quad (2.2.42)$$

holds with λ_m given by (2.2.40) and $\nu_m = \xi_m^{1/(\gamma_m^+ - \gamma_m^-)} I(\xi_m > 0)$, for every $m = 1, \dots, n$, where ξ_m has the form of (2.2.41). We also observe that the inequalities in (2.2.42) can hold for K_2

if either $L_m > \delta_m L_{m-1}/(\lambda_{m+1}r)$ when $\xi_m \leq 1$, or $L_m > \delta_m \nu_m L_{m-1}/(\lambda_{m+1}r)$ when $\xi_m > 1$. However, the property of (2.2.42) does not hold if either $L_{m-1} < L_m \leq \delta_m L_{m-1}/(\lambda_{m+1}r)$ when $\xi_m \leq 1$, or $\nu_m L_{m-1} < L_m \leq \delta_m \nu_m L_{m-1}/(\lambda_{m+1}r)$ when $\xi_m > 1$, or $L_m \leq \nu_m L_{m-1}$ when $\xi_m > 1$ holds. Note that the last two cases are separated due to the fact that the property $\delta_m \nu_m L_{m-1}/r > \lambda_{m+1} L_m$ excludes $\delta_m \nu_m L_{m-1}/r > \delta_m L_m/r$ and vice versa.

Summarising the facts proved above, we can therefore formulate the following algorithm to specify the location interval $(L_{m-1}, L_m]$ for the solution b^* of the equation in (2.2.33), based on the corresponding relationships between K_2 , r , δ_i , L_i , λ_m , ξ_m , and ν_m for $i, m = 1, \dots, n$. Without loss of generality, let us thus assume that the strike price satisfies $L_{k-1} < K_2 \leq L_k$ for some $1 \leq k \leq n$, so that there exist $n - k + 1$ possible intervals in which the solution b^* can be located. Note that, after finding a solution $L_{m-1} < b_m^* \leq L_m$ of the equation in (2.2.33) for some $m = n, \dots, k + 2$ going backwards, we can get another solution $L_{i-1} < b_i^* \leq L_i$ if $\xi_i > 0$ and $K_2 \leq \lambda_i L_{i-1}$ holds for some $l = m - 1, \dots, k + 1$ and $l > i$. We further denote by b^* the maximum over such solutions b_m^* , $m = n, \dots, k$, whenever they exist, and construct the corresponding solution $V(s; b^*)$ of the form in (2.2.7), which will dominate the other possible solutions of the second-order ordinary differential equation in (2.1.8), satisfying the conditions in (2.1.9)-(2.1.10) with b_m^* , $m = n, \dots, k$. The latter fact can be shown by means of the arguments similar to the ones used in [97; Chapter VI, Remark 23.2] and [97; Chapter VI, Theorem 24.1], or by verifying directly.

We can therefore start the following backward procedure started with $m = n$, so that the value function associated with the solution $L_{m-1} < b_m^* \leq L_m$ of the equation in (2.2.33), which is obtained first for a certain $m = n, \dots, k$, dominates all the forthcoming possible solutions. Hence the possibility of having other solutions $L_{i-1} < b_i^* \leq L_i$ for some $i < m - 1$, does not make any impact on the procedure described below:

(n) (searching for a solution in the interval $(L_{n-1}, L_n]$):

- (I) if $\delta_n L_{n-1}/r < K_2$ holds, then we look for a solution b_n^* in the smaller interval $(\overline{K}_{2,n}, L_n]$, thus if
 - (a) either $\xi_n \leq 1$ or $\xi_n > 1$ and $\delta_n \nu_n L_{n-1}/r < K_2$ hold, there exists a solution $\overline{K}_{2,n} < b_n^* \leq L_n$ of the equation in (2.2.33) for $m = n$ and the optimal stopping boundary is given by $b^* = b_n^*$,
 - (b) $\xi_n > 1$ and $K_2 \leq \delta_n \nu_n L_{n-1}/r$ hold, proceed with checking whether $\xi_i > 0$ and $K_2 \leq \lambda_i L_{i-1}$ hold for some $i = n, \dots, k + 1$, and in that case, continue with step **(i-1)**,
- (II) if $K_2 \leq \delta_n L_{n-1}/r$ holds, then we observe that if
 - (a) $\lambda_n L_{n-1} < K_2$ holds, then there exists a solution $\overline{K}_{2,n} < b_n^* \leq L_n$ of the equation in (2.2.33) for $m = n$ and the optimal stopping boundary is given by $b^* = b_n^*$,
 - (b) $K_2 \leq \lambda_n L_{n-1}$ holds, then continue with step **(n-1)**;

⋮

- (**m**) (searching for a solution in the interval $(L_{m-1}, L_m]$, for $m = n - 1, \dots, k + 1$):
- (I) if $\delta_m L_m / r < K_2$ holds, then the interval $(L_{m-1}, L_m]$ belongs to the continuation region, and we proceed further, when
 - (a) $\lambda_m L_{m-1} < K_2$ holds, with checking whether $\xi_i > 0$ and $K_2 \leq \lambda_i L_{i-1}$ hold for some $i = m - 1, \dots, k + 1$, and in that case, continue with step (**i-1**),
 - (b) $K_2 \leq \lambda_m L_{m-1}$ holds, continue with step (**m-1**),
 - (II) if $\delta_m L_{m-1} / r < K_2 \leq \delta_m L_m / r$ holds, then we check for a solution b_m^* in the smaller interval $(\bar{K}_{2,m}, L_m]$, thus if
 - (a) either $\xi_m \leq 1$ or $\xi_m > 1$ and $\delta_m \nu_m L_{m-1} / r < K_2$ hold, there exists a solution $\bar{K}_{2,m} < b_m^* \leq L_m$ of the equation in (2.2.33) and the optimal stopping boundary is given by $b^* = b_m^*$,
 - (b) $\xi_m > 1$ and $K_2 \leq \delta_m \nu_m L_{m-1} / r$ hold, proceed with checking whether $\xi_i > 0$ and $K_2 \leq \lambda_i L_{i-1}$ hold for some $i = m, \dots, k + 1$, and in that case, continue with step (**i-1**),
 - (III) if $K_2 \leq \delta_m L_{m-1} / r$ holds, then observe that if
 - (a) $\lambda_m L_{m-1} < K_2$ holds, then there exists a solution $L_{m-1} < b_m^* \leq L_m$ of the equation in (2.2.33) and the optimal stopping boundary is given by $b^* = b_m^*$,
 - (b) $K_2 \leq \lambda_m L_{m-1}$ holds, then continue with step (**m-1**);

⋮

- (**k**) (searching for a solution in the interval $(\bar{K}_{2,k}, L_k]$):
- (I) if $\delta_k L_k / r < K_2$ holds, then the interval $(K_2, L_k]$ belongs to the continuation region,
 - (II) if $K_2 \leq \delta_k L_k / r$ holds, then observe that if
 - (a) either $\xi_k \leq 1$ or $\xi_k > 1$ and $\delta_k \nu_k L_{k-1} / r < K_2$ hold, then there exists a solution $\bar{K}_{2,k} < b_k^* \leq L_k$ of the equation in (2.2.33) for $m = k$ and the optimal stopping boundary is given by $b^* = b_k^*$,
 - (b) $\xi_k > 1$ and $K_2 \leq \delta_k \nu_k L_{k-1} / r$ hold, then there is no solution in the interval $(\bar{K}_{2,k}, L_k]$.

Observe that the algorithm presented above shows explicitly that there exist possible situations in which there does not exist any solution of the equation in (2.2.33) in anyone of the intervals $(\bar{K}_{2,m} \vee L_{m-1}, L_m]$, for $m = n, \dots, k$, and in this case we set $b^* = \infty$. For instance, such a situation can occur at part (I)(b) of step (**n**), under the conditions $\lambda_n L_{n-1} < K_2$ and $\xi_i < 0$, for all $i = n - 1, \dots, k + 1$.

However, taking into account the analysis above, we conclude that there are various ways to guarantee the existence of an optimal stopping time in the case of call option. The simplest conditions we can impose in order to characterize directly the existence of an optimal stopping

time are as follows. If $0 < K_2 < L_1$ holds, we can choose the underlying parameters such that the inequality

$$r K_2 < \delta_1 L_1 \quad (2.2.43)$$

is satisfied, while if $L_{k-1} \leq K_2 < L_k$ holds for some $k = 2, \dots, n$, we can choose the underlying parameters such that the inequalities

$$\xi_i \leq 1 \quad \text{and} \quad r K_2 < \delta_i L_i \quad (2.2.44)$$

are satisfied for all $i = k, \dots, n$. A violation of the condition in (2.2.43) or one of the conditions on the right-hand side of (2.2.44) for some i , yields that $L_i \leq \bar{K}_{2,i}$ holds. This fact means that it is impossible to have an optimal stopping boundary b_i^* in the interval $(L_{i-1}, L_i]$, since it follows from the free-boundary problem that $b_i^* \geq \bar{K}_{2,i}$ should hold for all $i = k, \dots, n$. If the parameters are such that these conditions are violated, then it is likely not to have an optimal stopping time for the case of call option, even though $\delta_i > 0$ for all $i = 1, \dots, n$. This, of course, also depends on other conditions as it is shown in the algorithm above.

2.2.4. Some remarks. Let us finally give some comments on the resulting algorithms in the cases of put and call options.

Remark 2.2.1 In the cases of the put or call option, the algorithms above describe how we begin from the interval $(0, L_1]$ or $(L_{n-1}, \infty]$, checking whether or not there exists an optimal stopping boundary a_1^* or b_n^* in these intervals, respectively. If such a boundary does not exist, the procedure moves to the next interval $(L_1, L_2]$ or $(L_{n-2}, L_{n-1}]$, etc. In any case, while checking the existence of an optimal stopping boundary a_i^* or b_i^* in $(L_{i-1}, L_i]$, it may happen that either $a_i^* = L_i$ or $b_i^* = L_i$ occurs. In such a case, it is straightforward to see that the algorithm for the call option works normally. Moreover, it can be seen that this fact creates no complication in what follows for the case of put option as well, since we ask for the value function to be smooth at the levels L_j , $j = 1, \dots, n-1$, and thus, the instantaneous-stopping and smooth-fit conditions are still satisfied for $s = a_i^* = L_i$, even though the process has different coefficients immediately before it exits the continuation region, when $s = L_i^-$.

2.3. Main results and proof

Taking into account the facts proved above, let us now formulate the main assertions of the chapter.

Theorem 2.3.1 *Suppose that the price process S of the underlying risky asset is defined by (2.1.1)-(2.1.2), and let $0 = L_0 < L_1 < \dots < L_{n-1} < L_n = \infty$, $n \in \mathbb{N}$, be some prescribed*

levels. Then, in the optimal stopping problems of (2.1.3), related to the perpetual American put and call options with strike prices $K_1, K_2 > 0$, the value functions are given by

$$V^*(s) = \begin{cases} K_1 - s, & \text{if } s \leq a^* \\ V(s; a^*), & \text{if } s > a^* \end{cases} \quad \text{or} \quad V^*(s) = \begin{cases} V(s; b^*), & \text{if } s < b^* \\ s - K_2, & \text{if } s \geq b^* \end{cases} \quad (2.3.1)$$

where the functions $V(s; a)$ and $V(s; b)$ and the optimal exercise time τ^* have the form of (2.2.7) and (2.1.6), respectively, and the optimal stopping boundaries a^* and b^* are specified as follows:

(i) in the put option case, the boundary a^* satisfies $L_{j-1} < a^* \leq L_j \wedge K_1$ for a certain $j = 1, \dots, n$, and it is specified as the minimal solution of the arithmetic equation in (2.2.17);

(ii) in the call option case, either the boundary b^* satisfies $\bar{K}_{2,m} \vee L_{m-1} < b^* \leq L_m$ for a certain $m = 1, \dots, n$, and it is specified as the maximal solution of the arithmetic equation in (2.2.33), or we have $m = n$ and $b^* = \infty$ and thus there is no optimal stopping boundary.

Since both parts of the assertion formulated above are proved in a similar way, we only give a proof for the problem related to the more complicated case of the perpetual American call option. It also follows from the results of the previous section that the value function $V^*(s)$ of the put (call) option in (2.3.1) is decreasing (increasing) and convex in every interval $(L_{i-1}, L_i]$ separately, for $i = 1, \dots, n$, and since it is smooth at every point L_i for $i = 1, \dots, n$, we conclude that it is decreasing (increasing) on the whole half line $(0, \infty)$.

Proof of part (ii). In order to verify the assertion stated above, it remains to show that the function $V^*(s)$ defined in the right-hand part of (2.3.1) coincides with the value function in the right-hand part of (2.1.3), and that the stopping time τ^* in the right-hand part of (2.1.6) is optimal with b^* either being the maximal solution of the equation in (2.2.33) or $b^* = \infty$. For this, let us denote by $V(s)$ the right-hand side of the right-hand expression in (2.3.1). Then, applying the local time-space formula from [91] (see also [97; Chapter II, Section 3.5] for a summary of the related results as well as further references) and taking into account the smooth-fit condition in the right-hand part of (2.1.10), we get that the expression

$$e^{-rt} V(S_t) = V(s) + M_t + \int_0^t e^{-ru} (\mathbb{L}V - rV)(S_u) I(S_u \neq L_i, i = 1, \dots, n-1, S_u \neq b^*) du \quad (2.3.2)$$

holds, where the process $M = (M_t)_{t \geq 0}$ defined by

$$M_t = \int_0^t e^{-ru} V'(S_u) \Sigma(S_u) S_u dB_u \quad (2.3.3)$$

is a continuous square integrable martingale with respect to the probability measure P . The latter fact can easily be observed, since the derivative $V'(s)$ and $\Sigma(s)$ are bounded functions.

By means of straightforward calculations, similar to those of the previous section, it can be verified that the conditions in the right-hand parts of (2.1.12) and (2.1.13) hold with b^* either being the maximal solution of the equation in (2.2.33) or $b^* = \infty$. It is also shown using the comparison arguments for solutions of second-order ordinary differential equations that, in the former case, $V(s)$ represents the maximal solution of the equation in (2.1.8) satisfying the conditions in the right-hand parts of (2.1.9)-(2.1.10). These facts together with the condition in the right-hand part of (2.1.11) yield that $(\mathbb{L}V - rV)(s) \leq 0$ holds for all $s \neq L_i$, $i = 1, \dots, n-1$, and $s \neq b^*$, as well as $V(s) \geq (s - K_2) \vee 0$ is satisfied for all $s > 0$. Moreover, since the time spent by the process S at the boundary b^* as well as at the levels L_i , $i = 1, \dots, n-1$, is of Lebesgue measure zero, the indicator which appears in the integral of (2.3.2) can be ignored. Hence, it follows from the expression in (2.3.2) that the inequalities

$$e^{-r(\tau \wedge t)} (S_{\tau \wedge t} - K_2) \vee 0 \leq e^{-r(\tau \wedge t)} V(S_{\tau \wedge t}) \leq V(s) + M_{\tau \wedge t} \quad (2.3.4)$$

hold for any stopping time τ of the process S started at $s > 0$. Then, taking the expectation with respect to P in (2.3.4), we get by means of Doob's optional sampling theorem (see, e.g. [69; Chapter I, Theorem 3.22]) that the inequalities

$$E_s[e^{-r(\tau \wedge t)} (S_{\tau \wedge t} - K_2) \vee 0] \leq E_s[e^{-r(\tau \wedge t)} V(S_{\tau \wedge t})] \leq V(s) + E_s[M_{\tau \wedge t}] = V(s) \quad (2.3.5)$$

hold for all $s > 0$. Thus, letting t go to infinity and using Fatou's lemma, we obtain

$$E_s[e^{-r\tau} (S_\tau - K_2) \vee 0] \leq E_s[e^{-r\tau} V(S_\tau)] \leq V(s) \quad (2.3.6)$$

for any stopping time τ and all $s > 0$. By virtue of the structure of the stopping time τ^* in the right-hand part of (2.1.6), it is readily seen that the equality in (2.3.6) holds with τ^* instead of τ when $s \geq b^*$.

It remains to show that the equality holds in (2.3.6) when τ^* replaces τ for $s < b^*$. By virtue of the fact that the function $V(s; b^*)$ and the boundary b^* satisfy the conditions in the right-hand parts of (2.1.8) and (2.1.9), it follows from the expression in (2.3.2) and the structure of the stopping time τ^* in the right-hand part of (2.1.6) that the equality

$$e^{-r(\tau^* \wedge t)} V(S_{\tau^* \wedge t}) = V(s) + M_{\tau^* \wedge t} \quad (2.3.7)$$

is satisfied for all $s < b^*$, where the process M is defined in (2.3.3). Observe that the variable $e^{-r\tau^*} (S_{\tau^*} - K_2) \vee 0$ is equal to zero on the event $\{\tau^* = \infty\}$ (P -a.s.), and the process $(M_{\tau^* \wedge t})_{t \geq 0}$ is a uniformly integrable martingale. Therefore, taking the expectations with respect to P and letting t go to infinity, we can apply the Lebesgue dominated convergence for the expression in (2.3.7) to obtain the equalities

$$E_s[e^{-r\tau^*} (S_{\tau^*} - K_2) \vee 0] = E_s[e^{-r\tau^*} V(S_{\tau^*})] = V(s) \quad (2.3.8)$$

for all $s < b^*$. The latter, together with the inequality in (2.3.6), implies the fact that $V(s)$ coincides with the function $V^*(s)$ from the right-hand part of (2.1.3), and τ^* from the right-hand part of (2.1.6) is an optimal stopping time. \square

Chapter 3

Optimal stopping games in models with different information flows

In this chapter, we study optimal stopping games associated with perpetual convertible bonds in an extension of the Black-Merton-Scholes model with random dividends under different information flows. In this type of contracts, the writers have a right to withdraw the bonds before the holders can exercise them, by converting the bonds into assets. We derive closed-form expressions for the value function and the stopping boundaries, in the case of accessible dividend rate policy, which is modeled by a continuous-time Markov chain. We also present the analysis of the associated parabolic-type free-boundary problem in the case of inaccessible dividend rate policy. In the latter case, the optimal exercise times are found as the first times at which the asset price process hits boundaries depending on the running state of the filtering dividend rate estimate. Finally, we present explicit estimates for the value function and the optimal exercise boundaries in the case in which the dividend rate is accessible to the writers but inaccessible to the holders of the bonds.

3.1. Preliminaries

In this section, we introduce the setting and notation of the optimal stopping game, which is related to the pricing of perpetual convertible bonds under partial information.

3.1.1. The model. Let us suppose that there exist a standard Brownian motion $B = (B_t)_{t \geq 0}$ on a probability space (Ω, \mathcal{G}, P) as well as a continuous-time Markov chain $\Theta = (\Theta_t)_{t \geq 0}$, with two states 0 and 1. Assume that Θ has initial distribution $\{1 - \pi, \pi\}$, for $\pi \in [0, 1]$, transition probability matrix $(1/2) \{1 + e^{-2\lambda t}, 1 - e^{-2\lambda t}; 1 - e^{-2\lambda t}, 1 + e^{-2\lambda t}\}$, for $t \geq 0$, and intensity matrix $\{-\lambda, \lambda; \lambda, -\lambda\}$, for some $\lambda \geq 0$ fixed. Moreover, suppose that the processes

B and Θ are independent. Let us define the process $S = (S_t)_{t \geq 0}$, started at some $s > 0$, by

$$S_t = s \exp \left(\int_0^t \left(r - \frac{\sigma^2}{2} - \delta_0 - (\delta_1 - \delta_0) \Theta_u \right) du + \sigma B_t \right) \quad (3.1.1)$$

which solves the stochastic differential equation

$$dS_t = (r - \delta_0 - (\delta_1 - \delta_0) \Theta_t) S_t dt + \sigma S_t dB_t \quad (S_0 = s) \quad (3.1.2)$$

where $\sigma > 0$ and $0 < \delta_i < r$, for every $i = 0, 1$, are some given constants.

Assume that the process S describes the risk-neutral dynamics of the market price of a dividend paying risky asset under a martingale measure P , where r is the interest rate of a riskless bank account and σ is the volatility coefficient. Suppose that Θ reflects the switching behavior of the economic state of the firm issuing the asset, from 0 (the firm is in the so-called *good* state) to 1 (the firm is in the so-called *bad* state) and vice versa. In those cases, the asset pays dividends at the rate δ_0 when $\Theta_t = 0$, and the dividend rate is δ_1 when $\Theta_t = 1$, for any $t \geq 0$. We let the time of each stay be exponentially distributed with parameter λ . Such a switching model was proposed by Shiryaev [105; Chapter III, Section 4a] for the description of the interest rate dynamics. Some other models with random dividends were earlier considered in the literature (see, e.g. Geske [53]), where the possibility of significant stochastic dividend effects on the rational values of contingent claims was emphasised. We now assume that the dividend rate regulation process $\delta_0 + (\delta_1 - \delta_0)\Theta$ is unknown to small investors trading in the market, who can only observe the dynamics of the asset price S .

It is shown by means of standard arguments (see, e.g. [79; Chapter IX] or [39; Chapter VIII]) that the asset price process S from (3.1.2) admits the representation

$$dS_t = (r - \delta_0 - (\delta_1 - \delta_0) \Pi_t) S_t dt + \sigma S_t d\bar{B}_t \quad (S_0 = s) \quad (3.1.3)$$

on the filtration $\mathcal{F}_t = \sigma(S_u | 0 \leq u \leq t)$, and the filtering estimate $\Pi = (\Pi_t)_{t \geq 0}$ defined by $\Pi_t = E[\Theta_t | \mathcal{F}_t] \equiv P(\Theta_t = 1 | \mathcal{F}_t)$ solves the stochastic differential equation

$$d\Pi_t = \lambda(1 - 2\Pi_t) dt - \frac{\delta_1 - \delta_0}{\sigma} \Pi_t(1 - \Pi_t) d\bar{B}_t \quad (\Pi_0 = \pi) \quad (3.1.4)$$

for some $(s, \pi) \in (0, \infty) \times [0, 1]$ fixed. Here, the innovation process $\bar{B} = (\bar{B}_t)_{t \geq 0}$ defined by

$$\bar{B}_t = \int_0^t \frac{dS_u}{\sigma S_u} - \frac{1}{\sigma} \int_0^t (r - \delta_0 - (\delta_1 - \delta_0) \Pi_u) du \quad (3.1.5)$$

is a standard Brownian motion, according to P. Lévy's characterization theorem (see, e.g. [79; Theorem 4.1]). It can be verified that (S, Π) is a (time-homogeneous strong) Markov process under P with respect to its natural filtration $(\mathcal{F}_t)_{t \geq 0}$, as a unique strong solution of the system of stochastic differential equations in (3.1.3) and (3.1.4) (see, e.g. [86; Theorem 7.2.4]).

3.1.2. The optimal stopping game. Assume that a small investor writes a convertible bond on the underlying risky asset with the market price S and sells it to another small investor at time zero. Then, the holder of the bond can decide whether to continue holding it and collect the coupon payments at the rate $c + \rho S$, with some $c > 0$ and $\rho \geq 0$ fixed, or to terminate the contract by converting it into a unit of the asset and thus receive the (discounted) amount

$$Y_t = \int_0^t e^{-ru} (c + \rho S_u) du + e^{-rt} S_t \quad (3.1.6)$$

from the writer. The latter can recall the bond at some strike $K > 0$ and, at the same time, offers the holder an opportunity to convert the bond instantly. In other words, the writer can terminate the contract by paying the amount $\max\{K, S\} \equiv K \vee S$ to the holder and thus deliver the total (discounted) amount

$$Z_t = \int_0^t e^{-ru} (c + \rho S_u) du + e^{-rt} (K \vee S_t) \quad (3.1.7)$$

to the holder, at any time $t \geq 0$.

Taking into account the fact that the holder looks for a converting time maximising the expected discounted amount received from the writer, while the latter looks for a recalling time minimising the same quantity, such a contract can be expressed as a standard game contingent claim. More precisely, it follows from the results of Kifer [73] and Kallsen and Kühn [68] (see also [46]) that the rational (or no-arbitrage) price of such a claim coincides with the value of the optimal stopping game

$$\begin{aligned} V_*(s, \pi) &= \inf_{\zeta} \sup_{\tau} E_{s, \pi} [Y_{\tau} I(\tau < \zeta) + Z_{\zeta} I(\zeta \leq \tau)] \\ &= \sup_{\tau} \inf_{\zeta} E_{s, \pi} [Y_{\tau} I(\tau < \zeta) + Z_{\zeta} I(\zeta \leq \tau)] \end{aligned} \quad (3.1.8)$$

where $P_{s, \pi}$ is a probability measure of the diffusion process (S, Π) starting at some $(s, \pi) \in (0, \infty) \times [0, 1]$ and solving the two-dimensional system of equations in (3.1.3) and (3.1.4), while $I(\cdot)$ denotes the indicator function. The infimum and the supremum in (3.1.8) are therefore taken over all stopping times ζ and τ of (S, Π) . Note that in case $c \geq rK$, the solution of the problem (3.1.8) is trivial, so that we further assume that $c < rK$. We also suppose that $\rho < \delta_i$ for both $i = 0, 1$, since otherwise, the coupon payments for the convertible bond will exceed the dividend payments of the underlying asset. Some other optimal stopping problems for essentially two-dimensional diffusion processes were recently studied in [50]-[51] and [45].

3.1.3. The structure of optimal stopping times. By means of the general theory of optimal stopping problems for Markov processes (see, e.g. [97; Chapter I, Section 2.2]), it follows from the structure of the lower and upper processes Y and Z in (3.1.6)-(3.1.7),

respectively, that the optimal stopping times at which the writer and the holder of the bond should terminate the contract are given by

$$\tau_* = \inf\{t \geq 0 \mid V_*(S_t, \Pi_t) = S_t\} \quad \text{and} \quad \zeta_* = \inf\{t \geq 0 \mid V_*(S_t, \Pi_t) = K \vee S_t\} \quad (3.1.9)$$

whenever they exist. Then, using the results of general theory of optimal stopping games (see, e.g. [32], [14]-[15], [40]-[41], [75], [78], and [22]), we may therefore conclude from the structure of the value function in (3.1.8) that the continuation region has the form

$$C_* = \{(s, \pi) \in (0, \infty) \times [0, 1] \mid s < V_*(s, \pi) < K\} \quad (3.1.10)$$

and belongs to the rectangle $\{(s, \pi) \in (0, K) \times [0, 1]\}$. These arguments also imply that only one of the scenarios, $\tau_* < \zeta_*$, or $\zeta_* < \tau_*$, or $\zeta_* = \tau_*$ ($P_{s,\pi}$ -a.s.), can be realised for each starting point (s, π) of the process (S, Π) , whenever the optimal stopping times in (3.1.9) exist.

(i) Let us first assume that for (s, π) fixed, the scenario $\tau_* < \zeta_*$ ($P_{s,\pi}$ -a.s.) is realised. Then, applying Itô's formula (see, e.g. [79; Theorem 4.4]) to the function $e^{-rt}s$, we obtain from (3.1.3) and (3.1.6) the representation

$$Y_t = s + \int_0^t e^{-ru} H(S_u, \Pi_u) du + N_t \quad \text{with} \quad N_t = \int_0^t e^{-ru} \sigma S_u d\bar{B}_u \quad (3.1.11)$$

where we set $H(s, \pi) = c + (\rho - \delta_0 - (\delta_1 - \delta_0)\pi)s$, and the process $N = (N_t)_{t \geq 0}$ is a continuous square integrable martingale under $P_{s,\pi}$. Hence, applying Doob's optional sampling theorem (see, e.g. [79; Theorem 3.6]), we get from the expression in (3.1.11) that

$$E_{s,\pi} Y_\tau = s + E_{s,\pi} \int_0^\tau e^{-ru} H(S_u, \Pi_u) du \quad (3.1.12)$$

holds for any stopping time τ and all $(s, \pi) \in (0, \infty) \times [0, 1]$. It is seen from (3.1.12) and (3.1.10) that it is never optimal to stop whenever $H(S_t, \Pi_t) > 0$ and $S_t < K$ for any $0 \leq t < \zeta_*$ ($P_{s,\pi}$ -a.s.). This shows that all the points (s, π) satisfying $0 < s < \underline{b}(\pi)$, with $\underline{b}(\pi) = (c/(\delta_0 + (\delta_1 - \delta_0)\pi - \rho)) \wedge K$ for $\pi \in [0, 1]$, belong to the continuation region C_* in (3.1.10).

Let us now fix some $(s, \pi) \in C_*$ and let $\tau_* = \tau_*(s, \pi)$ denote the optimal stopping time in the problem of (3.1.8). Then, by means of the results of general optimal stopping theory for Markov processes (see, e.g. [97; Chapter I, Section 2.2]), we conclude from the structure of the reward in (3.1.8) under the assumption $\tau_* < \zeta_*$ ($P_{s,\pi}$ -a.s.) and the expression in (3.1.12) that

$$V_*(s, \pi) - s = E_{s,\pi} \int_0^{\tau_*} e^{-ru} H(S_u, \Pi_u) du > 0 \quad (3.1.13)$$

holds. Hence, taking any s' such that $\underline{b}(\pi) < s' < s < K$ and using the explicit expression for the process S through its starting point in (3.1.1), we obtain from (3.1.12) that the inequalities

$$V_*(s', \pi) - s' \geq E_{s',\pi} \int_0^{\tau_*} e^{-ru} H(S_u, \Pi_u) du \geq E_{s,\pi} \int_0^{\tau_*} e^{-ru} H(S_u, \Pi_u) du \quad (3.1.14)$$

are satisfied. Thus, taking into account the fact that $0 < \delta_i < r$ for $i = 0, 1$, by virtue of the inequality in (3.1.13), we see that $(s', \pi) \in C_*$. These arguments, together with the convexity of the function $s \mapsto V_*(s, \pi)$ on $(0, \infty)$ under $\tau_* < \zeta_*$ ($P_{s, \pi}$ -a.s.), show the existence of a function $b_*(\pi)$ such that $\underline{b}(\pi) \leq b_*(\pi) \leq K$ holds, and therefore, all the points (s, π) satisfying $0 < s < b_*(\pi)$ and $\pi \in [0, 1]$ belong to the continuation region in (3.1.10).

For any $(s, \pi) \in C_*$ fixed, let us now take π' such that $\pi < \pi'$ if $\delta_0 > \delta_1$ (or $\pi' < \pi$ if $\delta_0 < \delta_1$), whenever $s < K$. Then, using the facts that (S, Π) is a time-homogeneous Markov process and $\tau_*(s, \pi)$ does not depend on π' , taking into account the comparison results for solutions of stochastic differential equations, we obtain from (3.1.12) that the inequalities

$$V_*(s, \pi') - s \geq E_{s, \pi'} \int_0^{\tau_*} e^{-ru} H(S_u, \Pi_u) du \geq E_{s, \pi} \int_0^{\tau_*} e^{-ru} H(S_u, \Pi_u) du \quad (3.1.15)$$

hold. By virtue of the inequality in (3.1.13), we may conclude that $(s, \pi') \in C_*$, so that the boundary $b_*(\pi)$ is increasing (decreasing) on $[0, 1]$, whenever $\delta_0 > \delta_1$ ($\delta_0 < \delta_1$).

(ii) Let us now assume that for (s, π) fixed, the scenario $\zeta_* < \tau_*$ ($P_{s, \pi}$ -a.s.) is realised. Then, applying the change-of-variable formula from [92] to the function $e^{-rt}(K \vee s)$, we obtain from (3.1.3) and (3.1.7) the representation

$$Z_t = K \vee s + \int_0^t e^{-ru} G(S_u, \Pi_u) du + \frac{1}{2} \int_0^t e^{-ru} I(S_u = K) d\ell_u^K(S) + N_t^K \quad (3.1.16)$$

where we set $G(s, \pi) = c + \rho s - (\delta_0 + (\delta_1 - \delta_0)\pi)sI(s > K) - rKI(s < K)$, and the process $\ell^K(S) = (\ell_t^K(S))_{t \geq 0}$ is the local time of S at the point K given by

$$\ell_t^K(S) = \lim_{\varepsilon \downarrow 0} \frac{1}{2\varepsilon} \int_0^t I(K - \varepsilon < S_u < K + \varepsilon) \sigma^2 S_u^2 du \quad (3.1.17)$$

as a limit in probability. Here, the process $N^K = (N_t^K)_{t \geq 0}$ defined by

$$N_t^K = \int_0^t e^{-ru} I(S_u > K) \sigma S_u d\bar{B}_u \quad (3.1.18)$$

is a continuous square integrable martingale under $P_{s, \pi}$. Hence, applying Doob's optional sampling theorem, we get from the expression (3.1.16) that

$$E_{s, \pi} Z_\zeta = K \vee s + E_{s, \pi} \left[\int_0^\zeta e^{-ru} G(S_u, \Pi_u) du + \frac{1}{2} \int_0^\zeta e^{-ru} I(S_u = K) d\ell_u^K(S) \right] \quad (3.1.19)$$

holds for any stopping time ζ and all $(s, \pi) \in (0, \infty) \times [0, 1]$. Taking into account the structure of the reward in (3.1.8) under the assumption $\zeta_* < \tau_*$ ($P_{s, \pi}$ -a.s.), it is seen from (3.1.19) and (3.1.10) that it is never optimal to stop whenever $G(S_t, \Pi_t) < 0$ and $S_t < K$ for any $0 \leq t < \tau_*$ ($P_{s, \pi}$ -a.s.). This shows that all points (s, π) such that $0 < s < \underline{a}$ with $\underline{a} = ((rK - c)/\rho) \wedge K$ belong to the continuation region in (3.1.10).

Let us now fix some $(s, \pi) \in C_*$ and let $\zeta_* = \zeta_*(s, \pi)$ denote the optimal stopping time in the problem of (3.1.8). Then, by means of the results of general optimal stopping theory for Markov processes, we conclude from the structure of the reward in (3.1.8) under the assumption $\zeta_* < \tau_*$ ($P_{s,\pi}$ -a.s.) and the expression in (3.1.19) that

$$V_*(s, \pi) - K = E_{s,\pi} \left[\int_0^{\zeta_*} e^{-ru} G(S_u, \Pi_u) du + \frac{1}{2} \int_0^{\zeta_*} e^{-ru} I(S_u = K) d\ell_u^K(S) \right] < 0 \quad (3.1.20)$$

holds. Taking into account the structure of the optimal stopping times in (3.1.9), we may conclude that the indicator and thus the whole second term in the right part of (3.1.20) can be set to zero. Hence, taking any s' such that $\underline{a} < s' < s < K$ and using the explicit expression for the process S through its starting point in (3.1.1), we obtain from (3.1.19) that the inequalities

$$V_*(s', \pi) - K \leq E_{s',\pi} \int_0^{\zeta_*} e^{-ru} G(S_u, \Pi_u) du \leq E_{s,\pi} \int_0^{\zeta_*} e^{-ru} G(S_u, \Pi_u) du \quad (3.1.21)$$

are satisfied. Thus, taking into account the fact that $0 < \delta_i < r$ for $i = 0, 1$, by virtue of the inequality in (3.1.20) we see that $(s', \pi) \in C_*$. These arguments, together with the concavity of the function $s \mapsto V_*(s, \pi)$ on $(0, K)$ under $\zeta_* < \tau_*$ ($P_{s,\pi}$ -a.s.), show the existence of a function $a_*(\pi)$ such that $\underline{a} \leq a_*(\pi) \leq K$ holds, and therefore, all the points (s, π) satisfying $0 < s < a_*(\pi)$ and $\pi \in [0, 1]$ belong to the continuation region in (3.1.10).

For any $(s, \pi) \in C_*$ fixed, let us now take π' such that $\pi' < \pi$ if $\delta_0 > \delta_1$ (or $\pi < \pi'$ if $\delta_0 < \delta_1$), whenever $s < K$. Then, using the facts that (S, Π) is a time-homogeneous Markov process and $\zeta_*(s, \pi)$ does not depend on π' , taking into account the comparison results for solutions of stochastic differential equations, we obtain from (3.1.19) that the inequalities

$$V_*(s, \pi') - K \leq E_{s,\pi'} \int_0^{\zeta_*} e^{-ru} G(S_u, \Pi_u) du \leq E_{s,\pi} \int_0^{\zeta_*} e^{-ru} G(S_u, \Pi_u) du \quad (3.1.22)$$

hold. By virtue of the inequality in (3.1.20), we may conclude that $(s, \pi') \in C_*$, so that the boundary $a_*(\pi)$ is decreasing (increasing) on $[0, 1]$, whenever $\delta_0 > \delta_1$ ($\delta_0 < \delta_1$).

(iii) Let us finally assume that for (s, π) fixed, the scenario $\zeta_* = \tau_*$ ($P_{s,\pi}$ -a.s.) is realised. Then, according to the arguments of two previous parts above, we may conclude directly from the structure of the value function in (3.1.8) and the optimal stopping times in (3.1.9) that $a_*(\pi) = b_*(\pi) = K$ and $V_*(s, \pi) = s$ for all $s \geq K$ and $\pi \in [0, 1]$, so that the continuation region in (3.1.10) coincides with the set $\{(s, \pi) \in (0, K) \times [0, 1]\}$ in this case.

Summarising the facts proved above, we are now ready to formulate the following assertion.

Lemma 3.1.1 *Suppose that $\sigma > 0$ and $0 < \delta_i < r$ for every $i = 0, 1$ in (3.1.1)-(3.1.2). Then, in the optimal stopping game of (3.1.8) with $c < rK$ and $\rho < \delta_i$, for every $i = 0, 1$, the optimal stopping times from (3.1.9) have the structure*

$$\tau_* = \inf\{t \geq 0 \mid S_t \geq b_*(\Pi_t)\} \quad \text{and} \quad \zeta_* = \inf\{t \geq 0 \mid S_t \geq a_*(\Pi_t)\} \quad (3.1.23)$$

so that the continuation region in (3.1.10) takes the form

$$C_* = \{(s, \pi) \in (0, K) \times [0, 1] \mid s < a_*(\pi) \wedge b_*(\pi)\} \quad (3.1.24)$$

where the functions $a_*(\pi)$ and $b_*(\pi)$ have the properties

$$b_*(\pi) : [0, 1] \rightarrow (0, K] \quad \text{is increasing / decreasing if } \delta_0 > \delta_1 / \delta_0 < \delta_1 \quad (3.1.25)$$

$$\underline{b}(\pi) \leq b_*(\pi) \leq K \quad \text{with } \underline{b}(\pi) = (c/(\delta_0 + (\delta_1 - \delta_0)\pi - \rho)) \wedge K \quad (3.1.26)$$

$$a_*(\pi) : [0, 1] \rightarrow (0, K] \quad \text{is decreasing / increasing if } \delta_0 > \delta_1 / \delta_0 < \delta_1 \quad (3.1.27)$$

$$\underline{a} \leq a_*(\pi) \leq K \quad \text{with } \underline{a} = ((rK - c)/\rho) \wedge K \quad (3.1.28)$$

for all $\pi \in [0, 1]$. Moreover, stopping the game simultaneously by both the writer and the holder cannot be optimal as long as the process S fluctuates in the interval $(0, K)$. This fact means that only one of the scenarios, $b_*(\pi) < a_*(\pi) = K$, $a_*(\pi) < b_*(\pi) = K$, $a_*(\pi) = b_*(\pi) = K$ for all $\pi \in [0, 1]$, can be realised.

3.2. The case of full information

In this section, we formulate the optimal stopping game in the corresponding model with *full information*, when both the writer and the holder of the convertible bond have access to the dividend policy of the issuing firm, which is modeled by the continuous Markov chain Θ . We derive a closed-form solution to the equivalent free-boundary problem resulting to Theorem 3.2.1.

3.2.1. The optimal stopping game. The associated optimal stopping game in the model with full information considers the computation of the value function

$$\begin{aligned} U_*(s, i) &= \inf_{\zeta'} \sup_{\tau'} E_{s,i} [Y_{\tau'} I(\tau' < \zeta') + Z_{\zeta'} I(\zeta' \leq \tau')] \\ &= \sup_{\tau'} \inf_{\zeta'} E_{s,i} [Y_{\tau'} I(\tau' < \zeta') + Z_{\zeta'} I(\zeta' \leq \tau')] \end{aligned} \quad (3.2.1)$$

where $P_{s,i}$ is a probability measure of the process (S, Θ) started at some $(s, i) \in (0, \infty) \times \{0, 1\}$. The supremum and infimum in (3.2.1) are taken over all stopping times τ' and ζ' with respect to the filtration $\mathcal{G}_t = \sigma(S_u, \Theta_u \mid 0 \leq u \leq t)$, $t \geq 0$. Since the continuous time Markov chain Θ is observable in this formulation, it follows from Lemma 3.1.1 that the optimal stopping times for the problem of (3.2.1) should be of the form

$$\tau'_* = \inf\{t \geq 0 \mid S_t \geq h_*(\Theta_t)\} \quad \text{and} \quad \zeta'_* = \inf\{t \geq 0 \mid S_t \geq g_*(\Theta_t)\} \quad (3.2.2)$$

for some functions $h_*(i)$ and $g_*(i)$, $i = 0, 1$, to be determined.

3.2.2. The free-boundary problem. By means of standard arguments based on the application of Itô's formula, it is shown that the infinitesimal operator $\mathbb{L}_{(S,\Theta)}$ of the process (S, Θ) from (3.1.1)-(3.1.2) acts on an arbitrary function $F(s, i)$, which is twice continuously differentiable on $(0, \infty)$ for $i = 0, 1$ fixed, according to the rule

$$\begin{aligned} (\mathbb{L}_{(S,\Theta)}F)(s, i) &= (r - \delta_0 - (\delta_1 - \delta_0)i) s F_s(s, i) + \frac{1}{2} \sigma^2 s^2 F_{ss}(s, i) \\ &\quad + \lambda \left(F(s, 1 - i) - F(s, i) \right) \end{aligned} \quad (3.2.3)$$

for all $(s, i) \in (0, \infty) \times \{0, 1\}$. Following the way of arguments from [62] (see also [65] for a more general model), we conclude that the function $U_*(s, i)$ and the boundaries $g_*(i)$ and $h_*(i)$ solve the coupled second-order ordinary differential free-boundary problem

$$(\mathbb{L}_{(S,\Theta)}U - rU)(s, i) = -(c + \rho s) \quad \text{for } 0 < s < g(i) \wedge h(i) \quad (3.2.4)$$

$$U(s, i) \Big|_{s=h(i)-} = h(i) \quad \text{if } h(i) \leq g(i) = K, \quad U(s, i) \Big|_{s=g(i)-} = K \quad \text{if } g(i) \leq h(i) = K \quad (3.2.5)$$

$$U(s, i) = s \quad \text{for } s > h(i), \quad \text{if } h(i) \leq g(i) = K, \quad (3.2.6)$$

$$U(s, i) = K \vee s \quad \text{for } s > g(i), \quad \text{if } g(i) \leq h(i) = K \quad (3.2.7)$$

$$s < U(s, i) < K \vee s \quad \text{for } 0 < s < g(i) \wedge h(i) \quad (3.2.8)$$

$$(\mathbb{L}_{(S,\Theta)}U - rU)(s, i) < -(c + \rho s) \quad \text{for } s > h(i), \quad h(i) \leq g(i) = K, \quad (3.2.9)$$

$$(\mathbb{L}_{(S,\Theta)}U - rU)(s, i) > -(c + \rho s) \quad \text{for } s > g(i), \quad g(i) \leq h(i) = K \quad (3.2.10)$$

with $g(i)$ and $h(i)$ instead of $g_*(i)$ and $h_*(i)$ and the additional conditions

$$U(s, i) \Big|_{s=0+} \quad \text{is finite} \quad (3.2.11)$$

$$U_s(s, i) \Big|_{s=h(i)-} = 1 \quad \text{if } h(i) < g(i) = K, \quad U_s(s, i) \Big|_{s=g(i)-} = 0 \quad \text{if } g(i) < h(i) = K \quad (3.2.12)$$

for the relevant cases (see subsection 3.2.3 below). Here, the *instantaneous-stopping*, *natural boundary*, and *smooth-fit* conditions in (3.2.5), (3.2.11) and (3.2.12), respectively, are satisfied for every $i = 0, 1$.

3.2.3. Solution of the free-boundary problem. In order to simplify the exposition and without loss of generality, we further assume that $\delta_0 > \delta_1$. Then, applying the same arguments as in Subsection 2.3 above, we thus conclude that the inequality $U_*(s, 0) \leq U_*(s, 1)$ holds for the value function in (3.2.1) implying the inequalities $h_*(0) \leq h_*(1)$ and $g_*(1) \leq g_*(0)$ for the optimal exercise boundaries. By means of straightforward computations, we obtain that the general solution of the two-dimensional system of second-order ordinary differential equations in (3.2.4) is given by

$$U(s, i) = \sum_{j=1}^4 C_j(i) s^{\beta_j} + A_i(s) \quad \text{with} \quad A_i(s) = \frac{(2\lambda + \delta_1 - (\delta_1 - \delta_0)i)\rho}{(\delta_0 + \lambda)(\delta_1 + \lambda) - \lambda^2} s + \frac{c}{r} \quad (3.2.13)$$

for $0 < s < g(1) \wedge h(0)$ and $i = 0, 1$, as well as

$$U(s, i) = \sum_{j=1}^2 D_j(i) s^{\gamma_{i,j}} + B_i(s) \quad \text{with} \quad B_i(s) = \frac{\rho + \lambda i}{\delta_i + \lambda} s + \frac{c + \lambda K(1 - i)}{r + \lambda} \quad (3.2.14)$$

for $g(1-i) \wedge h(1-i) < s < g(i) \wedge h(i) \leq K$, where i is uniquely chosen such that this interval for s exists, whenever such a situation is realised. Here $C_j(i)$, $j = 1, 2, 3, 4$, and $D_k(i)$, $k = 1, 2$, are some arbitrary constants, $\beta_4 < \beta_3 < 0 < \beta_2 < \beta_1$ are the roots of the corresponding characteristic equation

$$Q_0(\beta)Q_1(\beta) = \lambda^2 \quad \text{with} \quad Q_i(\beta) = r + \lambda - \beta(r - \delta_i) - \frac{1}{2}\beta(\beta - 1)\sigma^2 \quad (3.2.15)$$

and $\gamma_{i,2} < 0 < 1 < \gamma_{i,1}$ are explicitly given by

$$\gamma_{i,k} = \frac{1}{2} - \frac{r - \delta_i}{\sigma^2} - (-1)^k \sqrt{\left(\frac{1}{2} - \frac{r - \delta_i}{\sigma^2}\right)^2 + \frac{2(r + \lambda)}{\sigma^2}} \quad (3.2.16)$$

for every $i = 0, 1$ and $k = 1, 2$. Observe that we should have $C_j(i) = 0$, $j = 3, 4$, in (3.2.13), since otherwise $U(s, i) \rightarrow \pm\infty$ as $s \downarrow 0$, that must be excluded by virtue of the obvious fact that the value function in (3.2.1) is bounded under $s \downarrow 0$. The latter fact also follows from the property that 0 cannot be reached by the process S in a finite time, that is expressed by the condition of (3.2.11).

We further derive closed-form solutions for the free-boundary problem of (3.2.4)-(3.2.12) under four possible ordered combinations of optimal exercise boundaries $g(i)$ and $h(i)$, $i = 0, 1$, that can be realised.

(i) Suppose that the combination $h(0) \leq h(1) \leq K = g(0) = g(1)$ is realised. Then, applying the conditions of (3.2.5) and (3.2.12) to the functions in (3.2.13), under the assumption that $C_j(i) = 0$, $j = 3, 4$, and to the function in (3.2.14) for $i = 1$, we obtain that the equalities

$$C_j(0)Q_0(\beta_j) = C_j(1)\lambda \quad \text{for} \quad j = 1, 2 \quad (3.2.17)$$

as well as

$$\sum_{j=1}^2 C_j(0) h^{\beta_j}(0) + A_0(h(0)) = h(0), \quad \sum_{j=1}^2 C_j(0) \beta_j h^{\beta_j}(0) + h(0) A'_0(h(0)) = h(0) \quad (3.2.18)$$

and

$$\sum_{j=1}^2 D_j(1) h^{\gamma_{1,j}}(1) + B_1(h(1)) = h(1), \quad \sum_{j=1}^2 D_j(1) \gamma_{1,j} h^{\gamma_{1,j}}(1) + h(1) B'_1(h(1)) = h(1) \quad (3.2.19)$$

hold. Observe that, since the inequality $h(0) \leq h(1)$ holds, the function in (3.2.13)-(3.2.14) for $i = 1$, when the process Θ is in the state 1, should be continuously differentiable and thus the equalities

$$\sum_{j=1}^2 C_j(1) h^{\beta_j}(0) + A_1(h(0)) = \sum_{j=1}^2 D_j(1) h^{\gamma_{1,j}}(0) + B_1(h(0)) \quad (3.2.20)$$

and

$$\sum_{j=1}^2 C_j(1) \beta_j h^{\beta_j}(0) + h(0) A_1'(h(0)) = \sum_{j=1}^2 D_j(1) \gamma_{1,j} h^{\gamma_{1,j}}(0) + h(0) B_1'(h(0)) \quad (3.2.21)$$

are satisfied for $0 < h(0) < K$. Hence, solving the system in (3.2.18)-(3.2.21), we obtain that the solution of the free-boundary problem in (3.2.4)-(3.2.5) and (3.2.11)-(3.2.12) is given by

$$U(s, 0; h_*(0)) = C_1(0; h_*(0)) s^{\beta_1} + C_2(0; h_*(0)) s^{\beta_2} + A_0(s) \quad (3.2.22)$$

and

$$U(s, 1; h_*(0), h_*(1)) = C_1(1; h_*(0), h_*(1)) s^{\beta_1} + C_2(1; h_*(0), h_*(1)) s^{\beta_2} + A_1(s) \quad (3.2.23)$$

for $0 < s < h_*(0)$, as well as

$$U(s, 1; h_*(1)) = D_1(1; h_*(1)) s^{\gamma_{1,1}} + D_2(1; h_*(1)) s^{\gamma_{1,2}} + B_1(s) \quad (3.2.24)$$

for $h_*(0) \leq s < h_*(1)$, where

$$C_j(0; h_*(0)) = \frac{(1 - \beta_{3-j})r(A_0(h_*(0)) - h_*(0)) - c}{(\beta_{3-j} - \beta_j)r h_*^{\beta_j}(0)} \quad (3.2.25)$$

$$\begin{aligned} & C_j(1; h_*(0), h_*(1)) \quad (3.2.26) \\ &= \sum_{k=1}^2 \frac{(\beta_{3-j} - \gamma_{1,k})D_k(1; h_*(1))h_*^{\gamma_{1,k}}(0)}{(\beta_{3-j} - \beta_j)h_*^{\beta_j}(0)} + \frac{(\beta_{3-j} - 1)(r + \lambda)r(B_1(h_*(0)) - A_1(h_*(0))) - c\lambda}{(\beta_{3-j} - \beta_j)(r + \lambda)r h_*^{\beta_j}(0)} \end{aligned}$$

and

$$D_j(1; h_*(1)) = \frac{(1 - \gamma_{1,3-j})(r + \lambda)(B_1(h_*(1)) - h_*(1)) - c}{(r + \lambda)(\gamma_{1,3-j} - \gamma_{1,j})h_*^{\gamma_{1,j}}(1)} \quad (3.2.27)$$

for $j = 1, 2$, and the functions $A_i(s)$, $i = 1, 2$, and $B_1(s)$ are given in (3.2.13)-(3.2.14). Here, the couple $h_*(0)$ and $h_*(1)$ is determined as the unique solution of the system of equations in (3.2.17), having the form

$$C_j(0; h(0)) Q_0(\beta_j) = \lambda C_j(1; h(0), h(1)) \quad (3.2.28)$$

for $j = 1, 2$, where $Q_0(\beta_j)$ is given by (3.2.15). It is shown by means of standard arguments that the system in (3.2.28) is equivalent to

$$I_{1,1}(h(0)) = J_{1,1}(h(1)) \quad \text{and} \quad I_{1,2}(h(0)) = J_{1,2}(h(1)) \quad (3.2.29)$$

with

$$I_{1,k}(s) = \sum_{j=1}^2 (-1)^j \left(\frac{c}{r} \gamma_{1,3-k} \beta_{3-j} \left(Q_0(\beta_j) - \frac{\lambda^2}{\lambda + r} \right) - \frac{c}{r} \beta_1 \beta_2 Q_0(\beta_j) s^{-\gamma_{1,k}} \right. \\ \left. + \frac{(\delta_0 + \delta_1 - 2\rho) \lambda + \delta_1(\delta_0 - \rho)}{(\delta_0 + \lambda)(\delta_1 + \lambda) - \lambda^2} (\beta_{3-j} - 1) (\beta_j - \gamma_{1,3-k}) \left(Q_0(\beta_j) - \frac{\lambda^2}{\lambda + \delta_1} \right) s^{1-\gamma_{1,k}} \right) \quad (3.2.30)$$

and

$$J_{1,k}(s) = \frac{\lambda(\beta_1 - \beta_2)(\gamma_{1,1} - \gamma_{1,2})}{s^{\gamma_{1,k}}} \left((1 - \gamma_{1,3-k}) \frac{\rho - \delta_1}{\delta_1 + \lambda} s - \gamma_{1,3-k} \frac{c}{r + \lambda} \right) \quad (3.2.31)$$

for $k = 1, 2$. It follows from the inequality in (3.2.9) that $c/(\delta_1 - \rho) < h(1) \leq K$ and $c/(\delta_0 - \rho) < H_*(h(1)) < h(0) \leq h(1) \leq K$ holds, where $H_*(h(1))$ denotes the unique solution of the equation

$$\lambda(U(H, 1; h(1)) - H) = (\delta_0 - \rho)H - c \quad (3.2.32)$$

and $U(s, 1; h(1))$ is given by (3.2.24), for every $h(1)$ fixed. The existence of a unique solution of the latter equation on the interval $(c/(\delta_0 - \rho), h(1))$ follows from the facts that the function $U(s, 1; h(1)) - s$ is nonnegative and decreasing and satisfies $U(h(1), 1; h(1)) - h(1) = 0$, while the function $(\delta_0 - \rho)s - c$ is increasing, with the range $(0, (\delta_0 - \rho)h(1) - c)$. Therefore, the case $h(0) \leq h(1) \leq K = g(0) = g(1)$ can only be realised if $c/(\delta_1 - \rho) < K$ holds, that also guarantees that $H_*(h(1)) < K$ holds, under the assumption that $\delta_0 > \delta_1$.

Let us now proceed with the analysis of the system of equations in (3.2.29). For this, we observe from the expressions for the derivatives of the functions in (3.2.30)-(3.2.31), together with the facts that $1 < \beta_2 < \gamma_{1,1} < \beta_1$, $Q_0(\beta_1) < 0 < Q_0(\beta_2)$, and $\lambda^2/(\delta_1 + \lambda) < Q_0(\beta_2)$ hold, that the function $I_{1,1}(s)$ is increasing on $(0, \mu_{1,1})$, with $I_{1,1}(0+) = -\infty$ and $I_{1,1}(\mu_{1,1}) > 0$, and decreasing on $(\mu_{1,1}, \infty)$, with $I_{1,1}(\infty) = 0+$. Moreover, it is shown that the functions $J_{1,k}(s)$ are decreasing on $(0, c/(\delta_1 - \rho))$, with $J_{1,1}(0+) = \infty$, $J_{1,2}(0) = 0$, and $J_{1,k}(c/(\delta_1 - \rho)) < 0$, $k = 1, 2$, and increasing on $(c/(\delta_1 - \rho), \infty)$, with $J_{1,1}(\infty) = 0-$ and $J_{1,2}(\infty) = \infty$. We further distinguish the three subcases generated by the shape of the function $I_{1,2}(s)$ and specified by the location of the point $Q_0(\beta_2)$ with respect to the points $((\gamma_{1,1} - 1)L_1(\delta_1) + (\beta_2 - 1)L_2)/(\beta_1 - 1)$ and $(\gamma_{1,1}L_1(r) + \beta_2L_2)/\beta_1$, where the function $L_1(\delta)$ and the constant L_2 are defined by

$$L_1(\delta) = \frac{\lambda^2}{\delta + \lambda} \frac{\beta_1 - \beta_2}{\gamma_{1,1} - \beta_2} > 0 \quad \text{and} \quad L_2 = Q_0(\beta_1) \frac{\gamma_{1,1} - \beta_1}{\gamma_{1,1} - \beta_2} > 0 \quad (3.2.33)$$

for all $\delta > 0$. For instance, let us assume that the property $(\gamma_{1,1}L_1(\delta_1) + \beta_2L_2)/\beta_1 < Q_0(\beta_2)$ holds, and the two other subcases are analysed using arguments similar to the ones that follow. It is shown that the function $I_{1,2}(s)$ is increasing on $(0, \mu_{1,2})$, with $I_{1,2}(0) = 0$ and $I_{1,2}(\mu_{1,2}) > 0$, and decreasing on $(\mu_{1,2}, \infty)$, with $I_{1,2}(\infty) = -\infty$, where $\mu_{1,k}$ is the unique point at which the function $I_{1,k}(s)$ attains its maximum, for $k = 1, 2$.

Taking into account the shape of the functions in (3.2.29) as well as the fact that $h(0) \leq h(1) \leq K$ holds in this case, we obtain from the equation on the left-hand side of (3.2.29) that, for every $h(1) \in ((c/(\delta_1 - \rho)) \vee \bar{H}_1, K]$, there exists a unique $h(0) \in (H_1(0; (c/(\delta_1 - \rho)) \vee \bar{H}_1), H_1(0; K)]$, while from the equation on the right-hand side of (3.2.29) that, for every $h(1) \in ((c/(\delta_1 - \rho)) \vee \bar{H}_2, K \wedge \tilde{H}]$, there exists a unique $h(0) \in [H_2(0; K \wedge \tilde{H}), H_2(0; (c/(\delta_1 - \rho)) \vee \bar{H}_2)]$, where

$$H_i(0; s) = \sup\{h(0) \leq s \mid I_{1,i}(h(0)) = J_{1,i}(s)\}$$

and \bar{H}_i and \tilde{H} are the unique solutions of the equations

$$I_{1,i}(s) = J_{1,i}(s) \quad \text{and} \quad I_{1,2}(\mu_{1,2}) = J_{1,2}(s)$$

for $i = 1, 2$, respectively.

Therefore, the equations in (3.2.29) uniquely define an increasing function $h^+(1; h(0))$ on $(H_1(0; (c/(\delta_1 - \rho)) \vee \bar{H}_1), H_1(0; K))$, with the range $((c/(\delta_1 - \rho)) \vee \bar{H}_1, K)$, and a decreasing function $h^-(1; h(0))$ on $(H_2(0; K \wedge \tilde{H}), H_2(0; (c/(\delta_1 - \rho)) \vee \bar{H}_2))$, with the range $((c/(\delta_1 - \rho)) \vee \bar{H}_2, K \wedge \tilde{H})$. The curves associated with these functions can have at most one intersection point which has the coordinates $h_*(0)$ and $h_*(1)$ such that $H_1(0; (c/(\delta_1 - \rho)) \vee \bar{H}_1) \vee H_2(0; K \wedge \tilde{H}) < h_*(0) < H_1(0; K) \wedge H_2(0; (c/(\delta_1 - \rho)) \vee \bar{H}_2)$ and $(c/(\delta_1 - \rho)) \vee \bar{H}_1 \vee \bar{H}_2 < h^+(1; h_*(0)) = h_*(1) = h^-(1; h_*(0)) < K \wedge \tilde{H}$ holds.

(ii) Suppose that the combination $h(0) \leq K = h(1) = g(0) = g(1)$ is realised. Then, applying the conditions of (3.2.5) and (3.2.12) to the function in (3.2.13), under the assumption that $C_j(i) = 0$, $j = 3, 4$, we obtain that the equalities in (3.2.17)-(3.2.18) hold, while applying (3.2.5) to the function (3.2.14) for $i = 1$, when the process S hits the level K , we obtain that the equality

$$D_1(1) K^{\gamma_{1,1}} + D_2(1) K^{\gamma_{1,2}} + B_1(K) = K \tag{3.2.34}$$

holds as well. Observe that, since the inequality $h(0) \leq K$ holds, the function in (3.2.13)-(3.2.14) for $i = 1$, when the process Θ is in the state 1, should be continuously differentiable, and thus, the equalities in (3.2.20)-(3.2.21) hold. Hence, solving the system in (3.2.18), (3.2.34) and (3.2.20)-(3.2.21), we obtain that the solution of the free-boundary problem in (3.2.4)-(3.2.5), (3.2.11) and (3.2.12) for $i = 0$, is given by $U(s, 0; h_*(0))$ in (3.2.22) and

$$U(s, 1; h_*(0), K) = C_1(1; h_*(0), f(1)) s^{\beta_1} + C_2(1; h_*(0), f(1)) s^{\beta_2} + A_1(s) \tag{3.2.35}$$

for $0 < s < h_*(0)$, as well as

$$U(s, 1; K) = f(1) s^{\gamma_{1,1}} + ((K - B_1(K)) K^{-\gamma_{1,2}} - f(1) K^{\gamma_{1,1} - \gamma_{1,2}}) s^{\gamma_{1,2}} + B_1(s) \quad (3.2.36)$$

for $h_*(0) \leq s < K$, where $C_j(1; h_*(0), f(1))$, $j = 1, 2$, admits the representation of (3.2.26) with $D_1(1; h_*(1)) = f(1)$ and $D_2(1; h_*(1)) = (K - B_1(K)) K^{-\gamma_{1,2}} - f(1) K^{\gamma_{1,1} - \gamma_{1,2}}$, for an arbitrary variable $f(1)$, and the functions $A_1(s)$ and $B_1(s)$ are given by (3.2.13)-(3.2.14). Here, the couple $f_*(1)$ and $h_*(0)$ is determined as the unique solution of the system of equations in (3.2.17), having the form

$$C_j(0; h(0)) Q_0(\beta_j) = \lambda C_j(1; h(0), f(1)) \quad (3.2.37)$$

where $Q_0(\beta_j)$ is given by (3.2.15), for $j = 1, 2$. It is shown by means of standard arguments that the system in (3.2.37) is equivalent to

$$I_{1,1}(h(0)) = J_{2,1}(f(1)) \quad \text{and} \quad I_{1,2}(h(0)) = J_{2,2}(f(1)) \quad (3.2.38)$$

with $I_{1,k}(h(0))$, $k = 1, 2$, given by the equation in (3.2.30), as well as

$$J_{2,1}(f(1)) = \lambda (\beta_1 - \beta_2) (\gamma_{1,1} - \gamma_{1,2}) f(1) \quad (3.2.39)$$

and

$$J_{2,2}(f(1)) = \lambda (\beta_1 - \beta_2) (\gamma_{1,1} - \gamma_{1,2}) (K^{\gamma_{1,1} - \gamma_{1,2}} f(1) + (B_1(K) - K) K^{-\gamma_{1,2}}). \quad (3.2.40)$$

It follows from the inequality in (3.2.9) and the corresponding analysis presented in part (i) above that $c/(\delta_0 - \rho) < H_*(f(1)) < h(0) \leq K$ holds, where $H_*(f(1))$ denotes the unique solution of the equation

$$\lambda(U(H, 1; K) - H) = (\delta_0 - \rho)H - c \quad (3.2.41)$$

with $U(s, 1; K)$ given by (3.2.36), for every $f(1)$ fixed. Therefore, the case $h(0) \leq K = h(1) = g(0) = g(1)$ is realised if $c/(\delta_0 - \rho) < K$ holds, under the assumption that $\delta_0 > \delta_1$. In particular, this case is the only possible combination for the boundaries when $c/(\delta_0 - \rho) < K \leq c/(\delta_1 - \rho)$ holds and can also occur when $c/(\delta_1 - \rho) < K$ holds and the system of equations in (3.2.29) does not have a solution.

Let us now proceed with the analysis of the system of equations in (3.2.38). The properties of the function $I_{1,1}(s)$ in (3.2.30) are analysed in part (i) of this subsection, while the functions $J_{2,k}(s)$, $k = 1, 2$, in (3.2.39)-(3.2.40) are linear and increasing. We further consider a structurally different subcase, generated by the shape of the function $I_{1,2}(s)$ and specified by the location of the point $Q_0(\beta_2)$ with respect to $((\gamma_{1,1} - 1)L_1(\delta_1) + (\beta_2 - 1)L_2)/(\beta_1 - 1)$ and $(\gamma_{1,1}L_1(r) + \beta_2L_2)/\beta_1$, than the related one studied in part (i) above. Namely, assume

that $Q_0(\beta_2) < ((\gamma_{1,1} - 1)L_1(\lambda) + (\beta_2 - 1)L_2)/(\beta_1 - 1)$ holds, where $L_1(\delta)$ and L_2 are given in (3.2.33), and the two other subcases are analysed using arguments similar to the ones that follow. It is shown that $I_{1,2}(s)$ is decreasing on $(0, \mu_{1,2})$, with $I_{1,2}(0) = 0$ and $I_{1,2}(\mu_{1,2}) < 0$, and increasing on $(\mu_{1,2}, \infty)$, with $I_{1,2}(\infty) = \infty$, where $\mu_{1,2}$ is the unique point at which the function $I_{1,2}(s)$ attains its minimum.

Taking into account the shape of the functions in (3.2.38) as well as the fact that $h(0) \leq K$ holds in this case, it can be shown that the equation on the left-hand side of (3.2.38) implies that, for every $f(1) \in (-\infty, F_1(1; K)]$, there exists a unique $h(0) \in (0, K]$ when $K \leq \mu_{1,1}$ or, for every $f(1) \in [F_1(1; K), F_1(1; \mu_{1,1})]$, there exists a unique $h(0) \in [\mu_{1,1}, K]$ when $\mu_{1,1} < K$. Moreover, the equation on the right-hand side of (3.2.38) implies that, for every $f(1) \in (F_2(1; K), \bar{F}_1]$, there exists a unique $h(0) \in (0, K]$ when $K \leq \mu_{1,2}$ or, for every $f(1) \in [F_2(1; \mu_{1,2}), F_2(1; K)]$, there exists a unique $h(0) \in [\mu_{1,2}, K]$ when $\mu_{1,2} < K$, where

$$\bar{F}_1 = (\delta_1 - \rho)K^{1-\gamma_{1,1}}/(\delta_1 + \lambda) + cK^{-\gamma_{1,1}}/(r + \lambda)$$

and $F_i(1; s)$ is a unique solution of the equation

$$I_{1,i}(s) = J_{2,i}(F_i)$$

for $i = 1, 2$.

We may therefore conclude that if $c/(\delta_0 - \rho) < K \leq \mu_{1,1} \wedge \mu_{1,2}$ holds, the equations in (3.2.38) uniquely define an increasing function $h_1^+(0; f(1))$ on $(-\infty, F_1(1; K)]$ and a decreasing function $h_1^-(0; f(1))$ on $[F_2(1; K), \bar{F}_1)$, with the same range $(0, K]$. The curves associated with these functions can have at most one intersection point which has the coordinates $f_*(1)$ and $h_*(0)$ such that $F_2(1; K) \leq f_*(1) \leq F_1(1; K) \wedge \bar{F}_1$ and $0 < h_1^+(0; f_*(1)) = h_*(0) = h_1^-(0; f_*(1)) \leq K$ holds.

Furthermore, if $K > \mu_{1,1} \vee \mu_{1,2} \vee c/(\delta_0 - h)$ holds, the equations in (3.2.38) uniquely define a decreasing function $h_2^-(0; f(1))$ on $[F_1(1; K), F_1(1; \mu_{1,1})]$, with the range $[\mu_{1,1}, K]$, and an increasing function $h_2^+(0; f(1))$ on $[F_2(1; \mu_{1,2}), F_2(1; K)]$, with the range $[\mu_{1,2}, K]$. The curves associated with these functions can have at most one intersection point which has the coordinates $f_*(1)$ and $h_*(0)$ such that $F_1(1; K) \vee F_2(1; \mu_{1,2}) \leq f_*(1) \leq F_1(1; \mu_{1,1}) \wedge F_2(1; K)$ and $\mu_{1,1} \vee \mu_{1,2} \leq h_1^-(0; f_*(1)) = h_*(0) = h_2^+(0; f_*(1)) \leq K$ holds.

Moreover, the arguments above imply that, when $(c/(\delta_0 - \rho)) \vee \mu_{1,1} < K \leq \mu_{1,2}$ or $(c/(\delta_0 - h)) \vee \mu_{1,2} < K \leq \mu_{1,1}$ holds, the curves associated with the functions $h_1^-(0; f(1))$ and $h_2^-(0; f(1))$ or $h_1^+(0; f(1))$ and $h_2^+(0; f(1))$, respectively, can have several intersection points, with $h(0) \in (H_*(f(1)), K]$. In that case, we take the couple $f_*(1)$ and $h_*(0)$ such that $F_1(1; K) \vee F_2(1; K) \leq f_*(1) \leq \bar{F}_1 \wedge F_1(1; \mu_{1,1})$ and $\mu_{1,1} \leq h_1^-(0; f_*(1)) = h_*(0) = h_2^-(0; f_*(1)) \leq K$ holds or such that $F_2(1; \mu_{1,2}) \leq f_*(1) \leq F_1(1; K) \wedge F_2(1; K)$ and $\mu_{1,2} \leq h_1^+(0; f_*(1)) = h_*(0) = h_2^+(0; f_*(1)) \leq K$ holds, respectively, where $h_*(0)$ is chosen as the largest second coordinate among all possible

intersection points. The resulting solution $f_*(1)$ and $h_*(0)$ generates the value function which dominates the ones associated with other possible intersection points. This property agrees with the fact that the function $H_*(f(1)) = H_*(f(1); K)$ is decreasing in the variable $f(1)$, as well as increasing in the parameter K , which puts $h_*(0)$ close to K .

(iii) Suppose that the combination $g(1) \leq g(0) \leq K = h(0) = h(1)$ is realised. Then, applying the conditions of (3.2.5) and (3.2.12) to the function in (3.2.13), under the assumption that $C_j(i) = 0$, $j = 3, 4$, and to the function (3.2.14) for $i = 0$, we obtain that the equalities

$$\sum_{j=1}^2 C_j(1) g^{\beta_j}(1) + A_1(g(1)) = K, \quad \sum_{j=1}^2 C_j(1) \beta_j g^{\beta_j}(1) + g(1) A'_1(g(1)) = 0 \quad (3.2.42)$$

and

$$\sum_{j=1}^2 D_j(0) g^{\gamma_{0,j}}(0) + B_0(g(0)) = K, \quad \sum_{j=1}^2 D_j(0) \gamma_{0,j} g^{\gamma_{0,j}}(0) + g(0) B'_0(g(0)) = 0 \quad (3.2.43)$$

hold. Observe that, since the inequality $g(1) \leq g(0)$ holds, the function in (3.2.13)-(3.2.14) for $i = 0$, when the process Θ is in the state 0, should be continuously differentiable and thus the equalities

$$\sum_{j=1}^2 C_j(0) g^{\beta_j}(1) + A_0(g(1)) = \sum_{j=1}^2 D_j(0) g^{\gamma_{0,j}}(1) + B_0(g(1)) \quad (3.2.44)$$

and

$$\sum_{j=1}^2 C_j(0) \beta_j g^{\beta_j}(1) + g(1) A'_0(g(1)) = \sum_{j=1}^2 D_j(0) \gamma_{0,j} g^{\gamma_{0,j}}(1) + g(1) B'_0(g(1)) \quad (3.2.45)$$

are satisfied for some $0 < g(1) < K$. Hence, solving the system in (3.2.42)-(3.2.45), we obtain that the solution of the free-boundary problem in (3.2.4)-(3.2.5) and (3.2.11)-(3.2.12) is given by

$$U(s, 1; g_*(1)) = C_1(1; g_*(1)) s^{\beta_1} + C_2(1; g_*(1)) s^{\beta_2} + A_1(s) \quad (3.2.46)$$

and

$$U(s, 0; g_*(1), g_*(0)) = C_1(0; g_*(1), g_*(0)) s^{\beta_1} + C_2(0; g_*(1), g_*(0)) s^{\beta_2} + A_0(s) \quad (3.2.47)$$

for $0 < s < g_*(1)$, as well as

$$U(s, 0; g_*(0)) = D_1(0; g_*(0)) s^{\gamma_{0,1}} + D_2(0; g_*(0)) s^{\gamma_{0,2}} + B_0(s) \quad (3.2.48)$$

for $g_*(1) \leq s < g_*(0)$, where

$$C_j(1; g_*(1)) = \frac{r(\beta_{3-j} - 1)A_1(g_*(1)) + c - r\beta_{3-j}K}{r(\beta_j - \beta_{3-j})g_*^{\beta_j}(1)} \quad (3.2.49)$$

$$C_j(0; g_*(1), g_*(0)) = \sum_{k=1}^2 \frac{(\gamma_{0,k} - \beta_{3-i})D_k(0; g_*(0))g_*^{\gamma_{0,k}}(1)}{(\beta_j - \beta_{3-j})g_*^{\beta_j}(1)} + \frac{(\beta_{3-j} - 1)(r + \lambda)r(A_0(g_*(1)) - B_0(g_*(1))) - \lambda(rK - c)}{(r + \lambda)r(\beta_j - \beta_{3-j})g_*^{\beta_j}(1)} \quad (3.2.50)$$

and

$$D_j(0; g_*(0)) = \frac{((\gamma_{0,3-j} - 1)\lambda + \gamma_{0,3-j}r)(B_0(g_*(0)) - K) - rB_0(g_*(0)) + c}{(r + \lambda)(\gamma_{0,j} - \gamma_{0,3-j})g_*^{\gamma_{0,j}}(0)} \quad (3.2.51)$$

for every $j = 1, 2$, and the functions $A_i(s)$, $i = 1, 2$, and $B_0(s)$ are given by (3.2.13)-(3.2.14). Here, the couple $g_*(0)$ and $g_*(1)$ is determined as the unique solution of the system of equations in (3.2.17), having the form

$$C_j(0; g(1), g(0)) Q_0(\beta_j) = \lambda C_j(1; g(1)) \quad (3.2.52)$$

where $Q_0(\beta_j)$ is given by (3.2.15), for $j = 1, 2$. It is shown by means of standard arguments that the system in (3.2.52) is equivalent to

$$I_{3,1}(g(1)) = J_{3,1}(g(0)) \quad \text{and} \quad I_{3,2}(g(1)) = J_{3,2}(g(0)) \quad (3.2.53)$$

with

$$I_{3,k}(s) = \sum_{j=1}^2 (-1)^j \left(\frac{\lambda(rK - c)}{r} \beta_j (\beta_{3-j} - \gamma_{0,3-k}) Q_0(\beta_j) \left(\frac{Q_0(\beta_{3-j})}{\lambda + r} - 1 \right) s^{-\gamma_{0,k}} \right. \\ \left. + \frac{(\beta_j - 1)(\delta_0 + 2\lambda)\lambda\rho}{(\delta_0 + \lambda)(\delta_1 + \lambda) - \lambda^2} Q_0(\beta_j) \left(\beta_{3-j} - \gamma_{0,3-k} - (1 - \gamma_{0,3-k}) \frac{Q_0(\beta_{3-j})}{\lambda + \delta_0} \right) s^{1-\gamma_{0,k}} \right) \quad (3.2.54)$$

and

$$J_{3,k}(s) = \frac{Q_0(\beta_1)Q_0(\beta_2)(\beta_1 - \beta_2)}{s^{\gamma_{0,k}}} \left(\frac{(\gamma_{0,3-k} - 1)\rho}{\delta_0 + \lambda} s - \frac{\gamma_{0,3-k}(rK - c)}{r + \lambda} \right) \quad (3.2.55)$$

for $k = 1, 2$. It follows from the inequality in (3.2.10) that $(rK - c)/\rho < G_*(g(0)) \leq g(1) \leq g(0) \leq K$ holds, where $G_*(g(0))$ denotes the unique solution of the equation

$$\lambda(U(G, 0; g(0)) - K) = rK - \rho G - c \quad (3.2.56)$$

where $U(s, 0; g(0))$ is given by (3.2.48), for every $g(0)$ fixed. The existence of a unique solution of the latter equation on the interval $((rK - c)/\rho, g(0))$ follows from the facts that the function $\lambda(U(s, 0; g_*(0)) - K)$ is increasing and satisfies $U(g_*(0), 0; g_*(0)) = 0$, while the function $rK -$

$\rho G - c$ is linear and decreasing, with the range $(rK - \rho g(0) - c, 0)$. Therefore, the case $g(1) \leq g(0) \leq K = h(0) = h(1)$ can only be realised, if $c/r < K < c/(r - \rho)$ holds, regardless of whether the assumption $\delta_0 > \delta_1$ holds or not.

Let us now proceed with the analysis of the system of equations in (3.2.53). The derivatives of the functions in (3.2.54)-(3.2.55), together with the relations between the parameters indicated in the previous parts of this subsection, imply that the function $I_{3,1}(s)$ is increasing on $(0, \mu_{3,1})$, with $I_{3,1}(0+) = -\infty$ and $I_{3,1}(\mu_{3,1}) > 0$, and decreasing in $(\mu_{3,1}, \infty)$, with $I_{3,1}(\infty) = 0+$. Moreover, it is shown that the functions $J_{3,k}(s)$, $k = 1, 2$, are increasing on $(0, (rK - c)/\rho)$, with $J_{3,1}(0+) = -\infty$, $J_{3,2}(0) = 0$, and $J_{3,k}((rK - c)/\rho) > 0$, $k = 1, 2$, and decreasing in $((rK - c)/\rho, \infty)$, with $J_{3,1}(\infty) = 0+$ and $J_{3,2}(\infty) = -\infty$. We further distinguish the three subcases generated by the shape of the function $I_{3,2}(s)$ and specified by the location of the point $(\beta_2 - \beta_1)Q_0(\beta_1)Q_0(\beta_2) > 0$ with respect to the points $((\beta_1 - 1)L_3(\delta_0) + (\beta_2 - 1)L_4(\delta_0))/(\gamma_{0,1} - 1) > 0$ and $(\beta_1 L_3(r) + \beta_2 L_4(r))/\gamma_{0,1} > 0$, for the function $L_{i+2}(\delta)$ defined by

$$L_{i+2}(\delta) = (-1)^i (\delta + \lambda) (\gamma_{0,1} - \beta_{3-i}) Q_0(\beta_i) > 0 \quad (3.2.57)$$

for all $\delta > 0$ and $i = 1, 2$. For instance, we assume that the property $(\beta_2 - \beta_1)Q_0(\beta_1)Q_0(\beta_2) > ((\beta_1 - 1)L_3(r) + (\beta_2 - 1)L_4(r))/(\gamma_{0,1} - 1)$ holds, and the two other subcases are analysed using arguments similar to the ones that follow. It is shown that $I_{3,2}(s)$ is decreasing in $(0, \mu_{3,2})$, with $I_{3,2}(0) = 0$ and $I_{3,2}(\mu_{3,2}) < 0$, and increasing in $(\mu_{3,2}, \infty)$, with $I_{3,2}(\infty) = \infty$, where $\mu_{3,k}$ is the unique point at which the function $I_{3,k}(s)$ attains its maximum and minimum, for $k = 1, 2$, respectively.

Taking into account the shape of the functions in (3.2.53) as well as the fact that $g(1) \leq g(0) \leq K$ holds in this case, it can be shown that the equation on the left-hand side of (3.2.53) implies that, for every $g(0) \in (G_1(0; \mu_{3,1} \vee ((rK - c)/\rho)) \wedge G_1(0; (rK - c)/\rho) \wedge \overline{G}_1, (\overline{G}_1 \vee G_1(0; (rK - c)/\rho)) \wedge K]$, there exists a unique $g(1) \in ((\overline{G}_1 \wedge G_1(1; K)) \vee ((rK - c)/\rho)) \vee \mu_{3,1}I(\mu_{3,1} < \overline{G}_1), G_1(1; \overline{G}_1 \wedge K) \vee G_1(1; K)]$, while the equation on the right-hand side of (3.2.53) implies that, for every $g(0) \in [\overline{G}_2, G_2(0; (rK - c)/\rho) \wedge K]$, there exists a unique $g(1) \in [((rK - c)/\rho) \vee G_2(1; K), \overline{G}_2]$, where

$$G_i(0; s) = \sup\{g(0) \geq s \mid I_{3,i}(s) = J_{3,i}(g(0))\} \quad , \quad G_i(1; s) = \sup\{g(1) \leq s \mid I_{3,i}(g(1)) = J_{3,i}(s)\}$$

and

$$\overline{G}_i = \sup\{s > 0 \mid I_{3,i}(s) = J_{3,i}(s)\}$$

for $i = 1, 2$.

We may therefore conclude that the left-hand equation in (3.2.53) uniquely defines an increasing function $g_1^+(1; g(0))$ on $(G_1(0; \mu_{3,1} \vee ((rK - c)/\rho)) \wedge \overline{G}_1, \overline{G}_1 \wedge K]$, with the range $(\overline{G}_1 \vee ((rK - c)/\rho) \vee \mu_{3,1}, G_1(1; \overline{G}_1 \wedge K) \vee G_1(1; K)]$, or a decreasing function $g_1^-(1; g(0))$ on

$(\overline{G}_1, G_1(0; (rK - c)/\rho) \wedge K]$, with the range $(G_1(1; K) \vee ((rK - c)/\rho), \overline{G}_1]$, and the right-hand equation in (3.2.53) uniquely defines a decreasing function $g_2^-(1; g(0))$ on $[\overline{G}_2, G_2(0; (rK - c)/\rho) \wedge K]$, with the range $[((rK - c)/\rho) \vee G_2(1; K), \overline{G}_2]$. These facts directly imply that, when the function $g_1^+(1; g(0))$ is defined, the curves associated with the functions $g_1^+(1; g(0))$ and $g_2^-(1; g(0))$ can have at most one intersection point which has the coordinates $g_*(0)$ and $g_*(1)$ such that $G_1(0; \mu_{3,1} \vee (rK - c)/\rho \wedge \overline{G}_1) \vee \overline{G}_2 < g_*(0) \leq G_2(0; (rK - c)/\rho) \wedge \widehat{G}_1 \wedge K$ and $\overline{G}_1 \vee ((rK - c)/\rho) \vee \mu_{3,1} \vee G_2(1; K) < g_1^+(1; g_*(0)) = g_*(1) = g_2^-(1; g_*(0)) \leq (G_1(1; \overline{G}_1 \wedge K) \vee G_1(1; K)) \wedge \overline{G}_2$ holds.

On the other hand, when the function $g_1^-(1; g(0))$ is defined, the curves associated with the functions $g_1^-(0; g(1))$ and $g_2^-(0; g(1))$ can have several intersection points. In that case, we take the couple $g_*(0)$ and $g_*(1)$ such that $\overline{G}_1 \vee \overline{G}_2 < g_*(0) \leq G_1(0; (rK - c)/\rho) \wedge G_2(0; (rK - c)/\rho) \wedge K$ and $G_1(1; K) \vee ((rK - c)/\rho) \vee G_2(1; K) < g_1^-(1; g_*(0)) = g_*(1) = g_2^-(1; g_*(0)) \leq \overline{G}_1 \wedge \overline{G}_2$ holds, where $g_*(0)$ is chosen as the largest second coordinate among all possible intersection points. The resulting solution $g_*(0)$ and $g_*(1)$ generates the value function which dominates the ones associated with other possible intersection points. This property agrees with the fact that the function $G_*(g(0)) = G_*(g(0); K)$ is increasing in the variable $g(0)$ as well as increasing in the parameter K , which puts $g_*(1)$ close to $g_*(0)$.

(iv) Suppose that the above system of equations in (3.2.53) does not have $g(0)$ and $g(1)$ as a solution, and thus, the combination $g(1) \leq K = g(0) = h(0) = h(1)$ is realised. Then, applying the conditions of (3.2.5) and (3.2.12) to the function in (3.2.13), under the assumption that $C_j(i) = 0$, $j = 3, 4$, we obtain that the equalities (3.2.17) and (3.2.42) hold, while using the condition of (3.2.5) to the function (3.2.14) for $i = 0$, when the process S hits the level K , we obtain that the equality

$$D_1(0) K^{\gamma_{0,1}} + D_2(0) K^{\gamma_{0,2}} + B_2(K) = K \quad (3.2.58)$$

holds as well. Observe that, since the inequality $g(1) \leq K$ holds, the function in (3.2.13)-(3.2.14) for $i = 0$, when the process Θ is in the state 0, should be continuously differentiable and thus the equalities in (3.2.44)-(3.2.45) hold. Hence, solving the system in (3.2.42), (3.2.58) and (3.2.44)-(3.2.45), we obtain that the solution of the free-boundary problem in (3.2.4)-(3.2.5), (3.2.11) and (3.2.12) for $i = 1$, is given by the function $U(s, 1; g_*(1))$ in (3.2.46) and

$$U(s, 0; g_*(1), K) = C_1(0; g_*(1), f(0)) s^{\beta_1} + C_2(0; g_*(1), f(0)) s^{\beta_2} + A_0(s) \quad (3.2.59)$$

for $0 < s < g_*(1)$, as well as

$$U(s, 0; K) = f(0) s^{\gamma_{0,1}} + ((K - B_0(K)) K^{-\gamma_{0,2}} - f(0) K^{\gamma_{0,1} - \gamma_{0,2}}) s^{\gamma_{0,1}} + B_0(s) \quad (3.2.60)$$

for $g_*(1) \leq s < K$, where $C_j(0; g_*(1), f(0))$, $j = 1, 2$, admits the representation of the equation in (3.2.50) with $D_1(0; g_*(0)) = f(0)$ and $D_2(0; g_*(0)) = (K - B_0(K)) K^{-\gamma_{0,2}} - f(0) K^{\gamma_{0,1} - \gamma_{0,2}}$ for

an arbitrary variable $f(0)$, and the functions $A_0(s)$ and $B_0(s)$ are given by (3.2.13)-(3.2.14). Here, the couple $f_*(0)$ and $g_*(1)$ is determined as a unique solution of the system of equations in (3.2.17) given by

$$C_j(0; g(1), f(0)) Q_0(\beta_j) = \lambda C_j(1; g(1)) \quad (3.2.61)$$

where $Q_0(\beta_j)$ is given by (3.2.15), for $j = 1, 2$. It is shown by means of standard arguments that the system in (3.2.61) is equivalent to

$$I_{3,1}(g(1)) = J_{4,1}(f(0)) \quad \text{and} \quad I_{3,2}(g(1)) = J_{4,2}(f(0)) \quad (3.2.62)$$

with $I_{3,k}(g(1))$, $k = 1, 2$, given by the equation in (3.2.54), as well as

$$J_{4,1}(f(0)) = Q_0(\beta_1) Q_0(\beta_2) (\beta_1 - \beta_2) f(0) \quad (3.2.63)$$

and

$$J_{4,2}(f(0)) = Q_0(\beta_1) Q_0(\beta_2) (\beta_1 - \beta_2) (K^{\gamma_{0,1} - \gamma_{0,2}} f(0) + (B_0(K) - K) K^{-\gamma_{0,2}}). \quad (3.2.64)$$

It follows from the inequality in (3.2.10) and the relevant analysis presented in part (iii) above, that $(rK - c)/\rho < G_*(f(0)) < g(1) \leq K$ holds, where $G_*(f(0))$ denotes the unique solution of the equation

$$\lambda(U(G, 0; K) - K) = rK - \rho G - c \quad (3.2.65)$$

and $U(s, 0; K)$ is given by (3.2.60), for every $f(0)$ fixed. Therefore, this case can only occur when $c/r < K < c/(r - \rho)$ holds and the system of (3.2.53) does not have a solution.

Let us now proceed with the analysis of the system of equations in (3.2.62). The properties of the function $I_{3,1}(s)$ in (3.2.54) are analysed in part (iii) of this subsection, while the functions $J_{4,k}(f(0))$, $k = 1, 2$, in (3.2.63)-(3.2.64) are linear and increasing. We further consider the same structural subcase for the function $I_{3,2}(s)$ as in part (iii) above, and the two other subcases are analysed using arguments similar to the ones that follow.

Taking into account the shape of the functions in (3.2.62) as well as the fact that $g(1) \leq K$ holds in this case, it can be shown that the equation on the left-hand side of (3.2.62) implies that, for each $f(0) \in [F_1(0; K), \infty)$, there exists a unique $g(1) \in (0, K]$ when $K \leq \mu_{3,1}$ or, for every $f(0) \in [F_1(0; \mu_{3,1}), F_1(0; K)]$, there exists a unique $g(1) \in [\mu_{3,1}, K]$ when $\mu_{3,1} < K$. Moreover, the equation on the right-hand side of (3.2.62) implies that, for every $f(0) \in (\bar{F}_0, F_2(0; K)]$, there exists unique $g(1) \in (0, K]$ when $K \leq \mu_{3,2}$ or, for every $f(0) \in [F_2(0; K), F_2(0; \mu_{3,2})]$, there exists a unique $g(1) \in [\mu_{3,2}, K]$ when $\mu_{3,2} < K$, where

$$\bar{F}_0 = K^{-\gamma_{0,1}} ((\lambda(r - \rho) + r(\delta_0 - \rho))K / (\delta_0 + \lambda) - c) / (r + \lambda)$$

and $F_1(0; s)$ is the unique solution of the equation

$$I_{3,i}(s) = J_{4,i}(f(0))$$

for $i = 1, 2$.

We may therefore conclude that if $c/r < K \leq \mu_{3,1} \wedge \mu_{3,2} \wedge (c/(r - \rho))$ hold, the equations in (3.2.62) uniquely define a decreasing function $g_1^-(1; f(1))$ on $[F_1(0; K), \infty)$ and an increasing function $g_2^+(1; f(1))$ on $(\bar{F}_0, F_2(0; K)]$, with the same range $(0, K]$. The curves associated with these functions can have at most one intersection point which has the coordinates $f_*(0)$ and $g_*(1)$ such that $F_1(0; K) \vee \bar{F}_0 \leq f_*(0) \leq F_2(0; K)$ and $0 < g_1^-(1; f_*(0)) = g_*(1) = g_2^+(1; f_*(0)) \leq K$ holds.

Furthermore, if $\mu_{3,1} \vee \mu_{3,2} \vee (c/r) < K < c/(r - \rho)$ holds, the equations in (3.2.62) uniquely define an increasing function $g_1^+(1; f(0))$ on $[F_1(0; \mu_{3,1}), F_1(0; K)]$, with the range $[\mu_{3,1}, K]$, and a decreasing function $g_2^-(1; f(0))$ on $[F_2(0; K), F_2(0; \mu_{3,2})]$, with the range $[\mu_{3,2}, K]$. The curves associated with these functions can have at most one intersection point which has the coordinates $f_*(0)$ and $g_*(1)$ such that $F_1(0; \mu_{3,1}) \vee F_2(0; K) \leq f_*(0) \leq F_1(0; K) \wedge F_2(0; \mu_{3,2})$ and $\mu_{3,1} \vee \mu_{3,2} \leq g_1^+(1; f_*(0)) = g_*(1) = g_2^-(1; f_*(0)) \leq K$ holds.

Moreover, it follows from the arguments above that, when either $(c/r) \vee \mu_{3,2} < K \leq \mu_{3,1}$ or $(c/r) \vee \mu_{3,1} < K \leq \mu_{3,2}$ holds, the curves associated with the functions $g_1^-(1; f(0))$ and $g_2^-(1; f(0))$ or $g_1^+(1; f(0))$ and $g_2^+(1; f(0))$, respectively, can have several intersection points, with $g(1) \in (G_*(f(0)), K]$. In that case, we take the couple $f_*(0)$ and $g_*(1)$ such that $F_1(0; K) \vee F_2(0; K) \leq f_*(0) \leq F_2(0; \mu_{3,2})$ and $\mu_{3,2} \leq g_1^-(1; f_*(0)) = g_*(1) = g_2^-(1; f_*(0)) \leq K$ holds or such that $F_1(0; \mu_{3,1}) \vee \bar{F}_0 \leq f_*(0) \leq F_1(0; K) \wedge F_2(0; K)$ and $\mu_{3,1} \leq g_1^+(1; f_*(0)) = g_*(1) = g_2^+(1; f_*(0)) \leq K$ holds, respectively, where $g_*(1)$ is chosen as the largest second coordinate among all possible intersection points. The resulting solution $f_*(0)$ and $g_*(1)$ generates the value function which dominates the ones associated with other possible intersection points.

(v) Suppose that the combination $K = g(0) = g(1) = h(0) = h(1)$ is realised. Then, applying the condition of (3.2.5) to the function in (3.2.13) under the assumption that $C_j(i) = 0$, for $j = 3, 4$, we obtain that the equality (3.2.17) as well as

$$C_1(i) K^{\beta_1} + C_2(i) K^{\beta_2} + A_i(K) = K \quad (3.2.66)$$

holds for $i = 0, 1$. Hence, solving the system in (3.2.17) and (3.2.66), we obtain that the solution of the free-boundary problem in (3.2.4)-(3.2.5) and (3.2.11) is given by

$$U(s, i; K) = C_1(i) s^{\beta_1} + C_2(i) s^{\beta_2} + A_i(s) \quad (3.2.67)$$

for $0 < s < K$ and $i = 0, 1$, where

$$C_j(i) = \frac{Q_i(\beta_{3-j})A_i(K) - \lambda A_{1-i}(K) - (Q_i(\beta_{3-j}) - \lambda)K}{(Q_i(\beta_j) - Q_i(\beta_{3-j}))K^{\beta_i}} \quad (3.2.68)$$

for $j = 1, 2$ and $i = 0, 1$ and the functions $A_i(s)$, $i = 0, 1$, are defined in (3.2.13).

Taking into account the inequalities in (3.2.9)-(3.2.10), it is shown by means of straightforward calculations that the case $K = h(0) = h(1) = g(0) = g(1)$ is the only possible combination

for the boundaries, when $c/(r - \rho) \leq K \leq c/(\delta_0 - \rho)$ holds, under the assumption $\delta_0 > \delta_1$, and can also occur when either $c/(\delta_0 - \rho) < K$ and the systems in (3.2.29) and (3.2.38) do not have a solution, or $K < c/(r - \rho)$ holds and the systems in (3.2.53) and (3.2.62) do not have a solution.

We are now ready to formulate that main result of this section, concerning the solution of the convertible bond pricing problem under *full information*. This assertion can be proved using similar arguments as the proof of Theorem 3.3.1 below.

Theorem 3.2.1 *Let the process S be given by (3.1.1)-(3.1.2) and assume that $0 < \delta_1 < \delta_0 < r$ and $0 < c < rK$ holds. Then, the value function of the optimal stopping game in (3.2.1) admits the representation*

$$U_*(s, i) = \begin{cases} U(s, i; g_*(1 - i) \wedge h_*(1 - i), g_*(i) \wedge h_*(i)), & \text{if } 0 < s < g_*(1 - i) \wedge h_*(1 - i) < g_*(i) \wedge h_*(i) \\ U(s, i; g_*(i) \wedge h_*(i)), & \text{if either } g_*(1 - i) \wedge h_*(1 - i) \leq s < g_*(i) \wedge h_*(i) \\ & \text{or } 0 < s < g_*(i) \wedge h_*(i) \leq g_*(1 - i) \wedge h_*(1 - i) \\ s, & \text{if } s \geq h_*(i) \text{ and } h_*(i) \leq g_*(i) \\ K \vee s, & \text{if } s \geq g_*(i) \text{ and } g_*(i) < h_*(i) \end{cases} \quad (3.2.69)$$

and the optimal stopping times τ'_* and ζ'_* have the form of (3.2.2), where the functions $U(s, i; g_*(1 - i) \wedge h_*(1 - i), g_*(i) \wedge h_*(i))$ and $U(s, i; g_*(i) \wedge h_*(i))$ as well as the boundaries $g_*(i)$ and $h_*(i)$, for every $i = 0, 1$, are specified as follows:

(i) if $c < (\delta_0 - \rho)K$ holds, then we have $c/(\delta_i - \rho) \leq h_*(i) \leq g_*(i) = K$ and the function $U(s, 0; h_*(0))$ is given by (3.2.22) while the functions $U(s, 1; h_*(0), h_*(1))$ and $U(s, 1; h_*(1))$ are given by (3.2.23)-(3.2.24) when $c < (\delta_1 - \rho)K$ holds and the system in (3.2.29) admits a unique solution with $h_*(0)$ and $h_*(1)$, otherwise by (3.2.35)-(3.2.36) with $h_*(1) = K$ when the system in (3.2.38) admits a unique solution with $h_*(0)$, and otherwise by (3.2.67) with $h_*(0) = h_*(1) = K$;

(ii) if $(r - \rho)K < c < rK$ holds, then we have $(rK - c)/\rho \leq g_*(i) \leq h_*(i) = K$ and the function $U(s, 1; g_*(1))$ is given by (3.2.46) while the functions $U(s, 0; g_*(1), g_*(0))$ and $U(s, 0; g_*(0))$ are given by (3.2.47)-(3.2.48) when the system in (3.2.53) admits a unique solution with $g_*(0)$ and $g_*(1)$, otherwise by (3.2.59)-(3.2.60) with $g_*(0) = K$ when the system in (3.2.62) admits a unique solution with $g_*(1)$, and otherwise by (3.2.67) with $g_*(0) = g_*(1) = K$;

(iii) if $(\delta_0 - \rho)K \leq c \leq (r - \rho)K$ holds, then we have $g_*(i) = h_*(i) = K$ and the function $U(s, i; K)$ is given explicitly by (3.2.67), for $i = 0, 1$.

3.3. The case of partial information

Let us now recall the original optimal stopping problem, which consists of the computation of the value function in (3.1.8) and the optimal stopping boundaries $a_*(\pi)$ and $b_*(\pi)$ from (3.1.23), satisfying the conditions (3.1.25)-(3.1.28) in Lemma 3.1.1.

3.3.1. The free-boundary problem. By means of standard arguments based on the application of Itô's formula, it is shown that the infinitesimal operator $\mathbb{L}_{(S,\Pi)}$ of the process (S, Π) from (3.1.3)-(3.1.4) acts on an arbitrary bounded function $F(s, \pi)$ from the class $C^{2,2}$ on the set $(0, \infty) \times (0, 1)$ according to the rule:

$$\begin{aligned} (\mathbb{L}_{(S,\Pi)}F)(s, \pi) = & \left((r - \delta_0 - (\delta_1 - \delta_0)\pi) s F_s + \frac{1}{2} \sigma^2 s^2 F_{ss} - (\delta_1 - \delta_0) s \pi(1 - \pi) F_{s\pi} \right. \\ & \left. + \lambda(1 - 2\pi) F_\pi + \frac{1}{2} \left(\frac{\delta_1 - \delta_0}{\sigma} \right)^2 \pi^2(1 - \pi)^2 F_{\pi\pi} \right) (s, \pi) \end{aligned} \quad (3.3.1)$$

for all $(s, \pi) \in (0, \infty) \times (0, 1)$.

In order to find analytic expressions for the unknown value function $V_*(s, \pi)$ from (3.1.8) and the boundaries $a_*(\pi)$ and $b_*(\pi)$ from (3.1.23)-(3.1.24), we apply the results of general theory of optimal stopping problems for continuous time Markov processes (see, e.g. [58] and [97; Chapter IV, Section 8]) to formulate the associated free-boundary problem

$$(\mathbb{L}_{(S,\Pi)}V - rV)(s, \pi) = -(c + \rho s) \quad \text{for } 0 < s < a(\pi) \wedge b(\pi) \quad (3.3.2)$$

$$V(s, \pi)|_{s=b(\pi)-} = b(\pi) \quad \text{if } b(\pi) \leq a(\pi) = K, \quad V(s, \pi)|_{s=a(\pi)-} = K \quad \text{if } a(\pi) \leq b(\pi) = K \quad (3.3.3)$$

$$V(s, \pi) = s \quad \text{for } s > b(\pi) \quad \text{if } b(\pi) \leq a(\pi) = K \quad (3.3.4)$$

$$V(s, \pi) = K \vee s \quad \text{for } s > a(\pi) \quad \text{if } a(\pi) \leq b(\pi) = K, \quad (3.3.5)$$

$$s < V(s, \pi) < K \vee s \quad \text{for } 0 < s < a(\pi) \wedge b(\pi) \quad (3.3.6)$$

$$(\mathbb{L}_{(S,\Pi)}V - rV)(s, \pi) < -(c + \rho s) \quad \text{for } s > b(\pi) \quad \text{if } b(\pi) \leq a(\pi) = K \quad (3.3.7)$$

$$(\mathbb{L}_{(S,\Pi)}V - rV)(s, \pi) > -(c + \rho s) \quad \text{for } s > a(\pi) \quad \text{if } a(\pi) \leq b(\pi) = K \quad (3.3.8)$$

and the additional conditions

$$V(s, \pi)|_{s=0+} \quad \text{is bounded} \quad (3.3.9)$$

$$V_s(s, \pi)|_{s=b(\pi)-} = 1 \quad \text{if } b(\pi) \leq a(\pi) = K, \quad V_s(s, \pi)|_{s=a(\pi)-} = 0 \quad \text{if } a(\pi) \leq b(\pi) = K \quad (3.3.10)$$

$$V_\pi(s, \pi)|_{s=b(\pi)-} = 0 \quad \text{if } b(\pi) \leq a(\pi) = K, \quad V_\pi(s, \pi)|_{s=a(\pi)-} = 0 \quad \text{if } a(\pi) \leq b(\pi) = K \quad (3.3.11)$$

with $a(\pi)$ and $b(\pi)$ instead of $a_*(\pi)$ and $b_*(\pi)$. Here, the *instantaneous-stopping*, *natural boundary*, and *smooth-fit* conditions in (3.3.3), (3.3.9) and (3.3.10), respectively, are satisfied for all $\pi \in [0, 1]$.

Note that, unlike the system in (3.2.3)-(3.2.10) with (3.2.11)-(3.2.12) from the previous section, the partial differential free-boundary problem formulated above cannot, in general, be solved explicitly. The existence and uniqueness of classical as well as viscosity solutions of the variational inequalities associated with such free-boundary problems and their connection with the optimal stopping problems have been extensively studied in the literature (see, e.g. [41], [16], [75] or [86]). It particularly follows from the results of [41; Chapter XVI, Theorem 11.1] as well as [75; Chapter V, Section 3, Theorem 14] with [75; Chapter VI, Section 4, Theorem 12] that the free-boundary problem of (3.3.1)-(3.3.8) with (3.3.9)-(3.3.11) admits a unique solution.

However, it follows from the results of Theorem 3.2.1 that we can find a closed-form solution of the free-boundary problem formulated above under certain relations between the parameters of the model. More precisely, if $(\delta_0 + (\delta_1 - \delta_0)\pi - \rho)K \leq c \leq (r - \rho)K$ holds, then the function $V(s, \pi; K)$ defined by

$$V(s, \pi; K) = U(s, 0; K) (1 - \pi) + U(s, 1; K) \pi \quad (3.3.12)$$

for all $(s, \pi) \in (0, K] \times [0, 1]$, with $U(s, i; K)$, $i = 0, 1$, from (3.2.67)-(3.2.68), surprisingly solves the partial differential equation in (3.3.1)-(3.3.2) and satisfies the conditions of (3.3.3).

We can now formulate and prove the main result of this section concerning the solution of the convertible bond pricing problem under *partial information*.

Theorem 3.3.1 *Let the processes S and Π solve the stochastic differential equations in (3.1.3) and (3.1.4) and assume that that $0 < \delta_1 < \delta_0 < r$ and $0 < c < rK$ holds. Suppose that the monotone boundaries $a_*(\pi)$ and $b_*(\pi)$ satisfying the conditions in (3.1.25)-(3.1.28) are continuous. Then, the value function of the optimal stopping game in (3.1.8) admits the representation*

$$V_*(s, \pi) = \begin{cases} V(s, \pi; a_*(\pi) \wedge b_*(\pi)), & \text{if } 0 < s < a_*(\pi) \wedge b_*(\pi) \\ s, & \text{if } s \geq b_*(\pi) \text{ and } b_*(\pi) < a_*(\pi) \\ K \vee s, & \text{if } s \geq a_*(\pi) \text{ and } a_*(\pi) \leq b_*(\pi) \end{cases} \quad (3.3.13)$$

and the optimal stopping times τ_* and ζ_* have the form of (3.1.23), where the function $V(s, \pi; a_*(\pi) \wedge b_*(\pi))$ and the continuous and monotone boundaries $a_*(\pi)$ and $b_*(\pi)$, for each $(s, \pi) \in (0, \infty) \times [0, 1]$, are specified as follows:

(i) if $c < (\delta_0 + (\delta_1 - \delta_0)\pi - \rho)K$ holds, then we have $c/(\delta_0 + (\delta_1 - \delta_0)\pi - \rho) \leq b_*(\pi) \leq a_*(\pi) = K$ and $V(s, \pi; b_*(\pi))$ with $b_*(\pi)$ are determined by the left-hand system of (3.3.2)-(3.3.3) with (3.3.4), (3.3.6) and (3.3.9)-(3.3.11);

(ii) if $(r - \rho)K < c < rK$ holds, then we have $(rK - c)/\rho \leq a_*(\pi) \leq b_*(\pi) = K$ and $V(s, \pi; a_*(\pi))$ with $a_*(\pi)$ are determined by the right-hand system of (3.3.2)-(3.3.3) with (3.3.5)-(3.3.6) and (3.3.9)-(3.3.11);

(iii) if $(\delta_0 + (\delta_1 - \delta_0)\pi - \rho)K \leq c \leq (r - \rho)K$ holds, then we have $a_*(\pi) = b_*(\pi) = K$ and the function $V(s, \pi; K)$ is explicitly given by (3.3.12).

Proof. Let us denote by $V(s, \pi)$ the right-hand side of the expression in (3.3.13). Hence, applying the change-of-variable formula with local time on surfaces from [92] to $e^{-rt}V(s, \pi)$ with $a_*(\pi) \wedge b_*(\pi)$ and taking into account the smooth-fit conditions in (3.3.10), we obtain

$$\begin{aligned} e^{-rt} V(S_t, \Pi_t) &= V(s, \pi) + N_t^* \\ &+ \int_0^t e^{-ru} (\mathbb{L}_{(S, \Pi)} V - rV)(S_u, \Pi_u) I(S_u \neq a_*(\Pi_u), S_u \neq b_*(\Pi_u), S_u \neq K) du \\ &+ \frac{1}{2} \int_0^t e^{-ru} \left(V_s(S_{u+}, \Pi_u) - V_s(S_{u-}, \Pi_u) \right) I(S_u = K) d\ell_u^K(S) \end{aligned} \quad (3.3.14)$$

where the process $\ell^K(S)$ is defined in (3.1.17) and the process $N^* = (N_t^*)_{t \geq 0}$ given by

$$N_t^* = \int_0^t e^{-ru} V_s(S_u, \Pi_u) I(S_u \neq K) \sigma S_u d\bar{B}_u \quad (3.3.15)$$

is a continuous square integrable martingale with respect to $P_{s, \pi}$, being the probability measure under which the process (S, Π) solving (3.1.3) and (3.1.4) starts at $(s, \pi) \in (0, \infty) \times [0, 1]$.

It follows from the system in (3.3.2)-(3.3.5) and (3.3.7)-(3.3.8) that $(\mathbb{L}_{(S, \Pi)} V - rV)(s, \pi) \leq -(c + \rho s)$ for $0 < s < a_*(\pi)$, while $(\mathbb{L}_{(S, \Pi)} V - rV)(s, \pi) \geq -(c + \rho s)$ for $0 < s < b_*(\pi)$ and all $\pi \in [0, 1]$. It also follows from the condition (3.3.6) that $s \leq V(s, \pi) \leq K \vee s$ for all $(s, \pi) \in (0, \infty) \times [0, 1]$. Since the monotone boundaries $a_*(\pi)$ and $b_*(\pi)$ satisfying (3.1.25)-(3.1.28) are assumed to be continuous, we conclude from the structure of the stochastic differential equations in (3.1.3) and (3.1.4) that the time spent by the process S at the boundaries $a_*(\Pi)$ and $b_*(\Pi)$ as well as at the constant level K is of Lebesgue measure zero. This implies that the indicators which appear in the first integral of (3.3.14) and in the expression of (3.3.15) can be ignored. Moreover, the integral with respect to the local time $\ell^K(S)$ is equal to zero, since the process S will only hit the level K at most once. Hence, the expression in (3.3.14) together with the structure of the stopping times τ_* and ζ_* in (3.1.23) yield that the inequalities

$$\begin{aligned} Y_{\zeta_* \wedge \tau_* \wedge t} &\leq \int_0^{\zeta_* \wedge \tau_* \wedge t} e^{-ru} (c + \rho S_u) du + e^{-r(\zeta_* \wedge \tau_* \wedge t)} V(S_{\zeta_* \wedge \tau_* \wedge t}, \Pi_{\zeta_* \wedge \tau_* \wedge t}) \\ &\leq V(s, \pi) + N_{\zeta_* \wedge \tau_* \wedge t}^* \end{aligned} \quad (3.3.16)$$

and

$$\begin{aligned} Z_{\zeta \wedge \tau_* \wedge t} &\geq \int_0^{\zeta \wedge \tau_* \wedge t} e^{-ru} (c + \rho S_u) du + e^{-r(\zeta \wedge \tau_* \wedge t)} V(S_{\zeta \wedge \tau_* \wedge t}, \Pi_{\zeta \wedge \tau_* \wedge t}) \\ &\geq V(s, \pi) + N_{\zeta \wedge \tau_* \wedge t}^* \end{aligned} \quad (3.3.17)$$

hold for any stopping times ζ and τ of the process (S, Π) started at $(s, \pi) \in (0, K] \times [0, 1]$, and all $t \geq 0$. Then, taking the expectations with respect to the probability measure $P_{s, \pi}$ in (3.3.16)

and (3.3.17), by means of Doob's optional sampling theorem, we get that the inequalities

$$\begin{aligned}
& E_{s,\pi} \left[Y_{\tau \wedge t} I(\tau \wedge t < \zeta_*) + Z_{\zeta_*} I(\zeta_* \leq \tau \wedge t) \right] \\
& \leq E_{s,\pi} \left[\int_0^{\zeta_* \wedge \tau \wedge t} e^{-ru} (c + \rho S_u) du + e^{-r(\zeta_* \wedge \tau \wedge t)} V(S_{\zeta_* \wedge \tau \wedge t}, \Pi_{\zeta_* \wedge \tau \wedge t}) \right] \\
& \leq V(s, \pi) + E_{s,\pi} N_{\zeta_* \wedge \tau \wedge t}^* = V(s, \pi)
\end{aligned} \tag{3.3.18}$$

and

$$\begin{aligned}
& E_{s,\pi} \left[Y_{\tau_*} I(\tau_* < \zeta \wedge t) + Z_{\zeta \wedge t} I(\zeta \wedge t \leq \tau_*) \right] \\
& \geq E_{s,\pi} \left[\int_0^{\zeta \wedge \tau_* \wedge t} e^{-ru} (c + \rho S_u) du + e^{-r(\zeta \wedge \tau_* \wedge t)} V(S_{\zeta \wedge \tau_* \wedge t}, \Pi_{\zeta \wedge \tau_* \wedge t}) \right] \\
& \geq V(s, \pi) + E_{s,\pi} N_{\zeta \wedge \tau_* \wedge t}^* = V(s, \pi)
\end{aligned} \tag{3.3.19}$$

hold for all $(s, \pi) \in (0, K] \times [0, 1]$. According to the structure of the lower and upper processes in (3.1.6) and (3.1.7) and the stopping times in (3.1.9), it is obvious that the property

$$E_{s,\pi} \sup_{t \geq 0} Y_{(\zeta_* \vee \tau_*) \wedge t} \leq E_{s,\pi} \sup_{t \geq 0} Z_{(\zeta_* \vee \tau_*) \wedge t} < \infty \tag{3.3.20}$$

holds for all $(s, \pi) \in (0, K] \times [0, 1]$, and the variables $Y_{\zeta_* \vee \tau_*}$ and $Z_{\zeta_* \vee \tau_*}$ are bounded on the set $\{\zeta_* \vee \tau_* = \infty\}$. Hence, letting t go to infinity and using Fatou's lemma, we obtain that the inequalities

$$E_{s,\pi} \left[Y_{\tau} I(\tau < \zeta_*) + Z_{\zeta_*} I(\zeta_* \leq \tau) \right] \leq V(s, \pi) \leq E_{s,\pi} \left[Y_{\tau_*} I(\tau_* < \zeta) + Z_{\zeta} I(\zeta \leq \tau_*) \right] \tag{3.3.21}$$

are satisfied for any stopping times ζ and τ and all $(s, \pi) \in (0, K] \times [0, 1]$, from where the desired assertion follows directly. Actually, inserting ζ_* in place of ζ and τ_* in place of τ into the expression of (3.3.21), we obtain that the equality

$$E_{s,\pi} \left[Y_{\tau_*} I(\tau_* < \zeta_*) + Z_{\zeta_*} I(\zeta_* \leq \tau_*) \right] = V(s, \pi) \tag{3.3.22}$$

holds for all $(s, \pi) \in (0, K] \times [0, 1]$. □

3.3.2. Solution of the free-boundary problem in a particular case. Let us assume until the end of this section that $\lambda = 0$ and $\delta_0 + \delta_1 = 2r - \sigma^2$ holds. The first equality means that $\Theta_t = \Theta_0$ for all $t \geq 0$, where $P_{s,\pi}(\Theta_0 = 1) = \pi$ and $P_{s,\pi}(\Theta_0 = 0) = 1 - \pi$ for $\pi \in [0, 1]$. Such a situation happens when the issuing firm does not change the dividend policy which is unknown to small investors during the whole infinite time interval. In this case, we can define the process $Q = (Q_t)_{t \geq 0}$ by

$$Q_t = \frac{S_t^{-\eta} \Pi_t}{1 - \Pi_t} \quad \text{with} \quad \eta = \frac{\delta_0 - \delta_1}{\sigma^2} \tag{3.3.23}$$

for all $t \geq 0$. By means of Itô's formula, we get that the process Q admits the representation

$$dQ_t = \left(\frac{\lambda(1 - S_t^{2\eta} Q_t^2)}{S_t^\eta Q_t} - \frac{\eta}{2} (2r - \delta_0 - \delta_1 - \sigma^2) \right) Q_t dt \quad \left(Q_0 = q(s, \pi) \equiv \frac{s^{-\eta} \pi}{1 - \pi} \right) \quad (3.3.24)$$

for any $(s, \pi) \in (0, \infty) \times (0, 1)$. Moreover, the second-order linear partial differential equation in (3.3.1)-(3.3.2) degenerates into an ordinary one and the general solution of the latter equation takes the form

$$\begin{aligned} V(s, \pi) &= \tilde{V}(s, q(s, \pi)) \\ &= \sum_{j=1}^2 \tilde{C}_j(q(s, \pi)) s^{\gamma_{0,j}} F(\psi_{j1}, \psi_{j2}; \varphi_j; -s^\eta q(s, \pi)) + P(s, q(s, \pi)) \end{aligned} \quad (3.3.25)$$

where $\tilde{C}_j(q(s, \pi))$, for $j = 1, 2$, are some arbitrary twice continuously differentiable functions, $P(s, q(s, \pi))$ is a particular solution of the second-order ordinary differential equation resulting from (3.3.1)-(3.3.2) under the assumptions $\lambda = 0$ and $\delta_0 + \delta_1 = 2r - \sigma^2$, and we set

$$\psi_{kl} = \frac{\gamma_{0,k} - \gamma_{1,l}}{\eta} \quad \text{and} \quad \varphi_k = 1 + \frac{2}{\eta} \left(\gamma_{0,k} - \frac{1}{2} + \frac{r - \delta_0}{\sigma^2} \right) \quad (3.3.26)$$

for every $k, l = 1, 2$, where $\gamma_{0,j}$ is given by the equation in (3.2.16) with $\lambda = 0$. Here $F(\alpha, \beta; \gamma; x)$ denotes Gauss' hypergeometric function, which is defined by means of the expansion

$$F(\alpha, \beta; \gamma; x) = 1 + \sum_{m=1}^{\infty} \frac{(\alpha)_m (\beta)_m}{(\gamma)_m} \frac{x^m}{m!} \quad (3.3.27)$$

for $\gamma \neq 0, -1, -2, \dots$ and $(\gamma)_m = \gamma(\gamma + 1) \cdots (\gamma + m - 1)$, $m \in \mathbb{N}$, where Γ denotes Euler's Gamma function. Note that the series in (3.3.27) converges under all $|x| < 1$, and the appropriate analytic continuation into (certain parts of) the complex plane can be obtained through the same representation for any $\alpha, \beta, \gamma \in \mathbb{R}$ given and fixed. Moreover, the function in (3.3.27) admits the integral representation

$$F(\alpha, \beta; \gamma; x) = \frac{\Gamma(\gamma)}{\Gamma(\beta)\Gamma(\gamma - \beta)} \int_0^1 t^{\beta-1} (1-t)^{\gamma-\beta-1} (1-tx)^{-\alpha} dt \quad (3.3.28)$$

whenever $\gamma > \beta > 0$ (see, e.g. [1; Chapter XV] and [7; Chapter II]).

Taking into account the fact that $\gamma_{0,2} < 0 < 1 < \gamma_{0,1}$, we observe that $\tilde{C}_2(q(s, \pi)) = 0$ should hold in (3.3.25) under the assumption of $\delta_0 > \delta_1$, since otherwise $V(s, \pi) \rightarrow \pm\infty$ as $s \downarrow 0$, that must be excluded by virtue of the obvious fact that the value function in (3.1.8) is bounded under $s \downarrow 0$, for any $\pi \in (0, 1)$ fixed. Note that the same conclusion can be made based on the argument that 0 is a natural boundary for the process S , as in (3.3.9) in this case. Then, applying the conditions of (3.3.3) and (3.3.10) to the function in (3.3.25) with $V(s, \pi) = \tilde{V}(s, q(s, \pi))$ at the boundaries $\tilde{a}_*(q(s, \pi))$ and $\tilde{b}_*(q(s, \pi))$ which are uniquely

specified by the equations $\tilde{a}(q) = a_*(q)/(\tilde{a}^{-\eta}(q) + q)$ and $\tilde{b}(q) = b_*(q)/(\tilde{b}^{-\eta}(q) + q)$, as well as $\tilde{C}_2(q) = 0$, we get that the equalities

$$\tilde{C}_1(q) \tilde{a}^{\gamma_{0,1}}(q) F(\psi_{11}, \psi_{12}; \varphi_1; -\tilde{a}^\eta(q) q) + P(\tilde{a}(q), q) = K \quad \text{and} \quad (3.3.29)$$

$$\tilde{C}_1(q) (-\eta) \tilde{a}^{\gamma_{0,1}+\eta}(q) q \frac{\psi_{11}\psi_{12}}{\varphi_1} F(1 + \psi_{11}, 1 + \psi_{12}; 1 + \varphi_1; -\tilde{a}^\eta(q) q) \quad (3.3.30)$$

$$+ \tilde{C}_1(q) \gamma_{0,1} \tilde{a}^{\gamma_{0,1}}(q) F(\psi_{11}, \psi_{12}; \varphi_1; -\tilde{a}^\eta(q) q) + \tilde{a}(q) P_s(\tilde{a}(q), q) = 0, \quad (3.3.31)$$

hold if $\tilde{a}(q) \leq \tilde{b}(q) = K$, or

$$\tilde{C}_1(q) \tilde{b}^{\gamma_{0,1}}(q) F(\psi_{11}, \psi_{12}; \varphi_1; -\tilde{b}^\eta(q) q) + P(\tilde{b}(q), q) = \tilde{b}(q) \quad \text{and} \quad (3.3.32)$$

$$\tilde{C}_1(q) (-\eta) \tilde{b}^{\gamma_{0,1}+\eta}(q) q \frac{\psi_{11}\psi_{12}}{\varphi_1} F(1 + \psi_{11}, 1 + \psi_{12}; 1 + \varphi_1; -\tilde{b}^\eta(q) q) \quad (3.3.33)$$

$$+ \tilde{C}_1(q) \gamma_{0,1} \tilde{b}^{\gamma_{0,1}}(q) F(\psi_{11}, \psi_{12}; \varphi_1; -\tilde{b}^\eta(q) q) + \tilde{b}(q) P_s(\tilde{b}(q), q) = b(q), \quad (3.3.34)$$

hold if $\tilde{b}(q) \leq \tilde{a}(q) = K$, or

$$\tilde{C}_1(q) K^{\gamma_{0,1}} F(\psi_{11}, \psi_{12}; \varphi_1; -K^\eta q) + P(K, q) = K, \quad (3.3.35)$$

holds if $\tilde{a}(q) = \tilde{b}(q) = K$, for each $q > 0$ fixed. Hence, solving the system of (3.3.29)-(3.3.30), we get that in case $(r - \rho)K < c < rK$ holds, the solution of the free-boundary problem of (3.3.2) with the right-hand sides of (3.3.3) and (3.3.9)-(3.3.11) is given by

$$\tilde{V}(s, q; \tilde{a}_*(q)) = (K - P(\tilde{a}_*(q), q)) \left(\frac{s}{\tilde{a}_*(q)} \right)^{\gamma_{0,1}} \frac{F(\psi_{11}, \psi_{12}; \varphi_1; -s^\eta q)}{F(\psi_{11}, \psi_{12}; \varphi_1; -\tilde{a}_*^\eta(q) q)} + P(s, q) \quad (3.3.36)$$

for all $0 < s < \tilde{a}_*(q)$, where $\tilde{a}_*(q)$ is determined as a unique solution of the equation

$$\frac{F(1 + \psi_{11}, 1 + \psi_{12}; 1 + \varphi_1; -\tilde{a}^\eta(q) q)}{\varphi_1 F(\psi_{11}, \psi_{12}; \varphi_1; -\tilde{a}^\eta(q) q)} = \frac{\tilde{a}(q) P_s(\tilde{a}(q), q) + \gamma_{0,1} (K - P(\tilde{a}(q), q))}{\psi_{11} \psi_{12} \eta q (K - P(\tilde{a}(q), q)) \tilde{a}^\eta(q)} \quad (3.3.37)$$

for any $q > 0$ fixed. Then, solving the system of (3.3.32)-(3.3.33), we get that in case $c < (\delta_0 + (\delta_1 - \delta_0)\pi - \rho)K$ holds, the solution of the free-boundary problem of (3.3.2) with the left-hand sides of (3.3.3) and (3.3.9)-(3.3.11) is given by

$$\tilde{V}(s, q; \tilde{b}_*(q)) = (\tilde{b}_*(q) - P(\tilde{b}_*(q), q)) \left(\frac{s}{\tilde{b}_*(q)} \right)^{\gamma_{0,1}} \frac{F(\psi_{11}, \psi_{12}; \varphi_1; -s^\eta q)}{F(\psi_{11}, \psi_{12}; \varphi_1; -\tilde{b}_*^\eta(q) q)} + P(s, q) \quad (3.3.38)$$

for all $0 < s < \tilde{b}_*(q)$, where $\tilde{b}_*(q)$ is determined as a unique solution of the equation

$$\frac{F(1 + \psi_{11}, 1 + \psi_{12}; 1 + \varphi_1; -\tilde{b}^\eta(q) q)}{\varphi_1 F(\psi_{11}, \psi_{12}; \varphi_1; -\tilde{b}^\eta(q) q)} = \frac{\tilde{b}(q) (P_s(\tilde{b}(q), q) - 1) + \gamma_{0,1} (\tilde{b}(q) - P(\tilde{b}(q), q))}{\psi_{11} \psi_{12} \eta q (\tilde{b}(q) - P(\tilde{b}(q), q)) \tilde{b}^\eta(q)} \quad (3.3.39)$$

for any $q > 0$ fixed. The uniqueness of solutions of the equations in (3.3.37) and (3.3.39), which are implied by the smooth-fit conditions from (3.3.10)-(3.3.11), as well as the validity

of the inequalities in (3.3.6)-(3.3.8) follow from the uniqueness of the solution of the system in (3.3.2)-(3.3.8) with (3.3.9)-(3.3.11) above, and can also be verified using the properties of Gauss' hypergeometric function from (3.3.27). Finally, solving the equation in (3.3.35), we get that in case $(\delta_0 + (\delta_1 - \delta_0)\pi - \rho)K \leq c \leq (r - \rho)K$ holds, the solution of the free-boundary problem of (3.3.2) with (3.3.3) and (3.3.9) is given by

$$\tilde{V}(s, q; K) = (K - P(K, q)) \left(\frac{s}{K} \right)^{\gamma_{0,1}} \frac{F(\psi_{11}, \psi_{12}; \varphi_1; -s^\eta q)}{F(\psi_{11}, \psi_{12}; \varphi_1; -K^\eta q)} + P(s, q) \quad (3.3.40)$$

for all $0 < s < K$ and any $q > 0$ fixed.

Corollary 3.3.2 *Suppose that the assumptions of Theorem 3.3.1 are satisfied with $\lambda = 0$ and $\delta_0 + \delta_1 = 2r - \sigma^2$. Then, the value function of the optimal stopping game in (3.1.8) admits the representation of (3.3.13), where the function $V(s, \pi; a_*(\pi) \wedge b_*(\pi)) = \tilde{V}(s, q(s, \pi); \tilde{a}_*(q(s, \pi)) \wedge \tilde{b}_*(q(s, \pi)))$ with the boundaries $a_*(\pi)$ and $b_*(\pi)$ uniquely specified by the equations $a(\pi) = \tilde{a}_*(a^{-\eta}(\pi)\pi/(1 - \pi))$ and $b(\pi) = \tilde{b}_*(b^{-\eta}(\pi)\pi/(1 - \pi))$ are determined as follows:*

(i) *if $(r - \rho)K < c < rK$ holds, then we have $(rK - c)/\rho \leq a_*(\pi) \leq b_*(\pi) = K$ and $\tilde{V}(s, q; \tilde{a}_*(q))$ is given by (3.3.36) and the boundary $\tilde{a}_*(q)$ is uniquely determined by the equation in (3.3.37);*

(ii) *if $c < (\delta_0 + (\delta_1 - \delta_0)\pi - \rho)K$ holds, then we have $c/(\delta_0 + (\delta_1 - \delta_0)\pi - \rho) \leq b_*(\pi) \leq a_*(\pi) = K$ and $\tilde{V}(s, q; \tilde{b}_*(q))$ is given by (3.3.38) and the boundary $\tilde{b}_*(q)$ is uniquely determined by the equation in (3.3.39);*

(iii) *if $(\delta_0 + (\delta_1 - \delta_0)\pi - \rho)K \leq c \leq (r - \rho)K$ holds, then we have $\tilde{a}_*(q) = \tilde{b}_*(q) = K$ and the function $\tilde{V}(s, q; K)$ is given explicitly by (3.3.40).*

3.4. The case of asymmetric information

In this section, we consider the appropriate optimal stopping game in a model such that the writer of the convertible bond has access to the dividend rate policy of the issuing firm, which remains inaccessible by the holder of the bond.

3.4.1. The optimal stopping game. It follows from the arguments above that the rational price of the perpetual convertible bond in the model with *asymmetric information* is given by the value of the optimal stopping game

$$\begin{aligned} W_*(s, \pi) &= \inf_{\zeta'} \sup_{\tau} E_{s, \pi} [Y_\tau I(\tau < \zeta') + Z_{\zeta'} I(\zeta' \leq \tau)] \\ &= \sup_{\tau} \inf_{\zeta'} E_{s, \pi} [Y_\tau I(\tau < \zeta') + Z_{\zeta'} I(\zeta' \leq \tau)] \end{aligned} \quad (3.4.1)$$

where the infimum and supremum are taken over all stopping times ζ' and τ with respect to the filtrations $(\mathcal{G}_t)_{t \geq 0}$ and $(\mathcal{F}_t)_{t \geq 0}$, respectively. This means that the continuous-time Markov

chain Θ is observable by the writer but not by the holder of the bond in this formulation. Observe that the structure of the original (Bayesian) model with full information allows us to express the value function of (3.4.1) in the form

$$\begin{aligned} W_*(s, \pi) &= \inf_{\zeta'} \sup_{\tau} \sum_{i=0}^1 E_{s,i} [Y_{\tau} I(\tau < \zeta') + Z_{\zeta'} I(\zeta' \leq \tau)] (i\pi + (1-i)(1-\pi)) \\ &= \sup_{\tau} \inf_{\zeta'} \sum_{i=0}^1 E_{s,i} [Y_{\tau} I(\tau < \zeta') + Z_{\zeta'} I(\zeta' \leq \tau)] (i\pi + (1-i)(1-\pi)) \end{aligned} \quad (3.4.2)$$

for $(s, \pi) \in (0, \infty) \times [0, 1]$. The additive representation of (3.4.2) and the analysis presented in the previous sections allows us to formulate the following assertion.

Corollary 3.4.1 *Suppose that the assumptions of Theorems 3.2.1 and 3.3.1 hold with $0 < \delta_1 < \delta_0 < r$ and $0 < c < rK$. Then, the value function $W_*(s, \pi)$ of the optimal stopping game in (3.4.1) takes the form of $W_*(s, \pi) = U_*(s, 0)(1-\pi) + U_*(s, 1)\pi$ when $(r-\rho)K < c < rK$ holds, and $W_*(s, \pi) = V_*(s, \pi)$ when $c \leq (r-\rho)K$ is satisfied, for each $s > 0$ and $\pi \in [0, 1]$, as well as the optimal stopping times ζ'_* and τ_* have the form of (3.2.2) and (3.1.23), respectively.*

3.4.2. Concluding remarks. The results stated above concern the pricing of the convertible bond in a model in which the writer has additional information about the dividend rate policy of the firm issuing the asset. It is seen that in this case, the value of the convertible bond would generally exceed the corresponding value in the model in which both the writer and the holder have the same information about the dynamics of the underlying asset only. More precisely, if the scenario $\zeta'_* < \tau_*$ ($P_{s,\pi}$ -a.s.) is realised, then the inequality $W_*(s, \pi) \leq V_*(s, \pi)$ holds, while if the scenario $\tau_* \leq \zeta'_*$ ($P_{s,\pi}$ -a.s.) is realised, then the equality $W_*(s, \pi) = V_*(s, \pi)$ is satisfied. Therefore, we can interpret the difference $V_*(s, \pi) - W_*(s, \pi)$ as the profit of the writer due to the additional information about the dividend rate policy of the issuing firm, for each starting point $(s, \pi) \in (0, K] \times [0, 1]$ of the process (S, Π) .

Chapter 4

Optimal stopping problems in diffusion-type models with running maxima and drawdowns

In this chapter, we study optimal stopping problems related to the pricing of perpetual American options in an extension of the Black-Merton-Scholes model in which the dividend and volatility rates of the underlying risky asset depend on the running values of its maximum and maximum drawdown. The optimal stopping times of exercise are shown to be the first times at which the price of the underlying asset exits some regions restricted by certain boundaries depending on the running values of the associated maximum and maximum drawdown processes. We obtain closed-form solutions to the equivalent free-boundary problems for the value functions with smooth fit at the optimal stopping boundaries and normal reflection at the edges of the state space of the resulting three-dimensional Markov process. We derive first-order nonlinear ordinary differential equations and arithmetic equations for the optimal exercise boundaries of the perpetual American call, put and strangle options.

4.1. Preliminaries

In this section, we introduce the setting and notation of the three-dimensional optimal stopping problems which are related to the pricing of certain perpetual American options and formulate the equivalent free-boundary problems.

4.1.1. Formulation of the problem. For a precise formulation of the problem, let us consider a probability space (Ω, \mathcal{F}, P) with a standard Brownian motion $B = (B_t)_{t \geq 0}$. Assume

that there exists a process $X = (X_t)_{t \geq 0}$ given by

$$X_t = x \exp \left(\int_0^t \left(r - \delta(S_u, Y_u) - \frac{\sigma^2(S_u, Y_u)}{2} \right) du + \int_0^t \sigma(S_u, Y_u) dB_u \right) \quad (4.1.1)$$

where $\sigma(s, y) > 0$ and $0 < \delta(s, y) < r$ are continuously differentiable bounded functions on $[0, \infty]^2$. It follows that the process X solves the stochastic differential equation

$$dX_t = (r - \delta(S_t, Y_t)) X_t dt + \sigma(S_t, Y_t) X_t dB_t \quad (X_0 = x) \quad (4.1.2)$$

where $x > 0$ is given and fixed. Here, the associated with X *running maximum* process $S = (S_t)_{t \geq 0}$ and the corresponding *running maximum drawdown* process $Y = (Y_t)_{t \geq 0}$ are defined by

$$S_t = \max_{0 \leq u \leq t} X_u \vee s \quad \text{and} \quad Y_t = \max_{0 \leq u \leq t} (S_u - X_u) \vee y \quad (4.1.3)$$

for arbitrary $0 < s - y \leq x \leq s$, so that X is a diffusion-type process representing a unique solution of the stochastic differential equation in (4.1.2) (see, e.g. [79; Chapter IV, Theorem 4.6]).

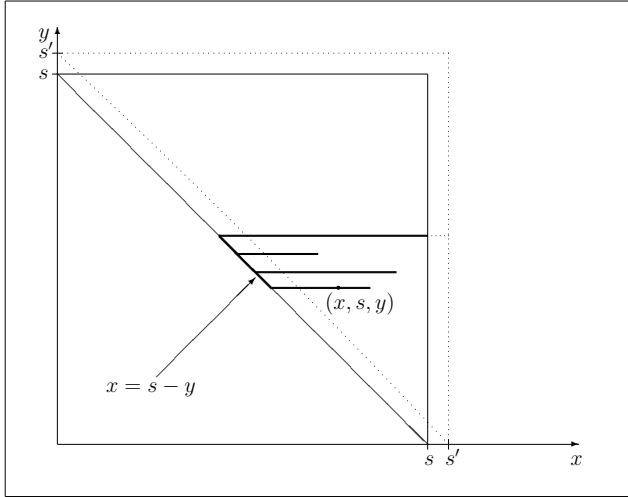

Figure 1. A computer drawing of the state space of the process (X, S, Y) , for some s fixed, which increases to s' .

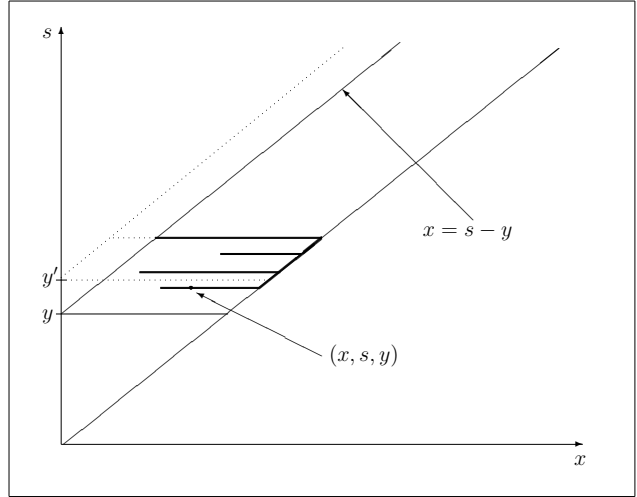

Figure 2. A computer drawing of the state space of the process (X, S, Y) , for some y fixed, which increases to y' .

The main purpose of the present chapter is to derive a closed-form solution to the optimal stopping problem for the time-homogeneous (strong) Markov process $(X, S, Y) = (X_t, S_t, Y_t)_{t \geq 0}$ given by

$$V_*(x, s, y) = \sup_{\tau} E_{x,s,y} \left[e^{-r\tau} \left((L - X_{\tau})^+ \vee (X_{\tau} - K)^+ \right) \right] \quad (4.1.4)$$

for any $(x, s, y) \in E^3$, where the supremum is taken over all stopping times τ with respect to the natural filtration of X , and $0 \leq L < K \leq \infty$ are some given constants. Here $E_{x,s,y}$ denotes the expectation under the assumption that the (three-dimensional) process (X, S, Y) defined in (4.1.1)-(4.1.3) starts at $(x, s, y) \in E^3$, and $E^3 = \{(x, s, y) \in \mathbb{R}^3 \mid 0 < s - y \leq x \leq s\}$ is the state space of the process (X, S, Y) . We assume that the process X describes the price of a

risky asset on a financial market, where r is the riskless interest rate, $\sigma(s, y)$ is the volatility rate, and $\delta(s, y)$ is the dividend rate paid to stockholders. The value of (4.1.4) is then actually a *rational* (or *no-arbitrage*) price of a perpetual American strangle option with payoff function $(L - x)^+ \vee (x - K)^+$, where the expectation is taken under the (unique) martingale measure (see, e.g. [105; Chapter VII, Section 3g]). In particular, when either $L = 0$ or $K = \infty$ holds, the resulting payoff functions $(x - K)^+$ and $(L - x)^+$ correspond to the ones of the perpetual American call and put options, respectively.

4.1.2. The structure of the optimal stopping times. It follows from the general theory of optimal stopping problems for Markov processes (see, e.g. [97; Chapter I, Section 2.2]) that the optimal stopping time in the problem of (4.1.4) is given by

$$\tau_* = \inf\{t \geq 0 \mid V_*(X_t, S_t, Y_t) = (L - X_t)^+ \vee (X_t - K)^+\}. \quad (4.1.5)$$

Taking into account the structure of the payoff function in (4.1.4), we further assume that the optimal stopping time from (4.1.5) takes the form

$$\tau_* = \inf\{t \geq 0 \mid X_t \notin (a_*(S_t, Y_t), b_*(S_t, Y_t))\} \quad (4.1.6)$$

for some functions $0 \leq a_*(s, y) < L < K < b_*(s, y) \leq \infty$ to be determined. This assumption means that the set

$$C' = \{(x, s, y) \in E^3 \mid a_*(s, y) < s - y \text{ and } s < b_*(s, y)\} \quad (4.1.7)$$

belongs to the continuation region for the optimal stopping problem of (4.1.4) which is given by

$$C_* = \{(x, s, y) \in E^3 \mid a_*(s, y) < x < b_*(s, y)\} \quad (4.1.8)$$

and the corresponding stopping region is the closure of the set

$$D_* = \{(x, s, y) \in E^3 \mid x < a_*(s, y) \text{ or } b_*(s, y) < x\}. \quad (4.1.9)$$

4.1.3. The free-boundary problem. By means of standard arguments based on the application of Itô's formula, it is shown that the infinitesimal operator \mathbb{L} of the process (X, S, Y) acts on a function $F(x, s, y)$ from the class $C^{2,1,1}$ on the interior of E^3 according to the rule

$$(\mathbb{L}F)(x, s, y) = (r - \delta(s, y))x \partial_x F(x, s, y) + \frac{\sigma^2(s, y)}{2} x^2 \partial_{xx}^2 F(x, s, y) \quad (4.1.10)$$

for all $0 < s - y < x < s$. It follows from the fact that the payoff function $(L - x)^+ \vee (x - K)^+$ is convex that the value function $V_*(x, s, y)$ is convex in the variable x , and thus, it is continuous in x on the interval $(0, \infty)$. In order to find analytic expressions for the unknown value function $V_*(x, s, y)$ from (4.1.4) and the unknown boundaries $a_*(s, y)$ and $b_*(s, y)$ from (4.1.6), let us

build on the results of general theory of optimal stopping problems for Markov processes (see, e.g. [97; Chapter IV, Section 8]). We can reduce the optimal stopping problem of (4.1.4) to the equivalent free-boundary problem for $V_*(x, s, y)$ with $a_*(s, y)$ and $b_*(s, y)$ given by

$$(\mathbb{L}V)(x, s, y) = rV(x, s, y) \quad \text{for } (x, s, y) \in C \quad (4.1.11)$$

$$V(x, s, y)|_{x=a(s,y)+} = L - a(s, y) \quad \text{and} \quad V(x, s, y)|_{x=b(s,y)-} = b(s, y) - K \quad (4.1.12)$$

$$V(x, s, y) = (L - x)^+ \vee (x - K)^+ \quad \text{for } (x, s, y) \in D \quad (4.1.13)$$

$$V(x, s, y) > (L - x)^+ \vee (x - K)^+ \quad \text{for } (x, s, y) \in C \quad (4.1.14)$$

$$(\mathbb{L}V)(x, s, y) < rV(x, s, y) \quad \text{for } (x, s, y) \in D \quad (4.1.15)$$

where C and D are defined as C_* and D_* in (4.1.8) and (4.1.9) with $a(s, y)$ and $b(s, y)$ instead of $a_*(s, y)$ and $b_*(s, y)$, respectively, and the instantaneous-stopping conditions in (4.1.12) are satisfied, when $s - y \leq a(s, y)$ and $b(s, y) \leq s$, respectively, for each $0 < y < s$. Observe that the superharmonic characterization of the value function (see [31] and [97; Chapter IV, Section 9]) implies that $V_*(x, s, y)$ is the smallest function satisfying (4.1.11)-(4.1.14), with the boundaries $a_*(s, y)$ and $b_*(s, y)$. Moreover, we further assume that the smooth-fit and normal-reflection conditions

$$\partial_x V(x, s, y)|_{x=a(s,y)+} = -1 \quad \text{and} \quad \partial_s V(x, s, y)|_{x=s-} = 0 \quad (4.1.16)$$

hold, when $s - y \leq a(s, y) < s < b(s, y)$, and the normal-reflection and smooth-fit conditions

$$\partial_y V(x, s, y)|_{x=(s-y)+} = 0 \quad \text{and} \quad \partial_x V(x, s, y)|_{x=b(s,y)-} = 1 \quad (4.1.17)$$

hold, when $a(s, y) < s - y < b(s, y) \leq s$, for each $0 < y < s$. Otherwise, the smooth-fit conditions in the left-hand part of (4.1.16) and in the right-hand part of (4.1.17) hold at $a(s, y)$ and $b(s, y)$, when $s - y \leq a(s, y) < b(s, y) \leq s$, while the normal-reflection conditions in the right-hand part of (4.1.16) and in the left-hand part of (4.1.17) hold, when $a(s, y) < s - y < s < b(s, y)$, for each $0 < y < s$.

Note that, when $\delta(s, y) = \delta(s)$ and $\sigma(s, y) = \sigma(s)$ holds in (4.1.1)-(4.1.2), the value function $V_*(x, s, y) = U_*(x, s)$ with the boundaries $a_*(s, y) = g_*(s)$ and $b_*(s, y) = h_*(s)$ satisfy the system of (4.1.11)-(4.1.15). Moreover, the smooth-fit and normal-reflection conditions

$$\partial_x U(x, s)|_{x=g(s)+} = -1 \quad \text{and} \quad \partial_s U(x, s)|_{x=s-} = 0 \quad (4.1.18)$$

hold, when $0 < g(s) < s < h(s)$, and the natural-boundary and smooth-fit conditions

$$U(x, s)|_{x=0+} = 0 \quad \text{and} \quad \partial_x U(x, s)|_{x=h(s)-} = 1 \quad (4.1.19)$$

hold, when $0 = g(s) < K < h(s) \leq s$, for each $s > 0$. Otherwise, the smooth-fit conditions in the left-hand part of (4.1.18) and in the right-hand part of (4.1.19) hold at $g(s)$ and $h(s)$, when $0 < g(s) < h(s) \leq s$, while the normal-reflection and natural-boundary conditions in the right-hand part of (4.1.18) and in the left-hand part of (4.1.19) hold respectively, when $g(s) = 0 < s < h(s)$, for each $0 < y < s$.

4.2. Solution of the free-boundary problem

In this section, we obtain closed-form expressions for the value functions $V_*(x, s, y)$ in (4.1.4) for the payoffs of standard call, put, and strangle options, and derive explicit expressions and ordinary differential equations for the optimal exercise boundaries $a_*(s, y)$ and $b_*(s, y)$ from (4.1.6), as solutions to the free-boundary problem of (4.1.11)-(4.1.17).

4.2.1. The general solution of the free-boundary problem. We first observe that the general solution of the equation in (4.1.11) has the form

$$V(x, s, y) = C_1(s, y) x^{\gamma_1(s, y)} + C_2(s, y) x^{\gamma_2(s, y)} \quad (4.2.1)$$

where $C_i(s, y)$, $i = 1, 2$, are some arbitrary continuously differentiable functions and $\gamma_2(s, y) < 0 < 1 < \gamma_1(s, y)$ are given by

$$\gamma_i(s, y) = \frac{1}{2} - \frac{r - \delta(s, y)}{\sigma^2(s, y)} - (-1)^i \sqrt{\left(\frac{1}{2} - \frac{r - \delta(s, y)}{\sigma^2(s, y)}\right)^2 + \frac{2r}{\sigma^2(s, y)}} \quad (4.2.2)$$

for all $0 < y < s$. Hence, applying the instantaneous-stopping conditions from (4.1.12) to the function in (4.2.1), we get that the equalities

$$C_1(s, y) a^{\gamma_1(s, y)}(s, y) + C_2(s, y) a^{\gamma_2(s, y)}(s, y) = L - a(s, y) \quad (4.2.3)$$

$$C_1(s, y) b^{\gamma_1(s, y)}(s, y) + C_2(s, y) b^{\gamma_2(s, y)}(s, y) = b(s, y) - K \quad (4.2.4)$$

hold, when $s - y \leq a(s, y)$ and $b(s, y) \leq s$, respectively, for each $0 < y < s$. Moreover, using the smooth-fit conditions from the left-hand part of (4.1.16) and the right-hand part of (4.1.17), we obtain that the equalities

$$C_1(s, y) \gamma_1(s, y) a^{\gamma_1(s, y)}(s, y) + C_2(s, y) \gamma_2(s, y) a^{\gamma_2(s, y)}(s, y) = -a(s, y) \quad (4.2.5)$$

$$C_1(s, y) \gamma_1(s, y) b^{\gamma_1(s, y)}(s, y) + C_2(s, y) \gamma_2(s, y) b^{\gamma_2(s, y)}(s, y) = b(s, y) \quad (4.2.6)$$

hold, when $s - y \leq a(s, y)$ and $b(s, y) \leq s$, respectively, for each $0 < y < s$. Finally, applying the normal-reflection conditions from the right-hand part of (4.1.16) and the left-hand part of

(4.1.17) to the function in (4.2.1), we have that the equalities

$$\sum_{i=1}^2 \left(\partial_s C_i(s, y) s^{\gamma_i(s, y)} + C_i(s, y) \partial_s \gamma_i(s, y) s^{\gamma_i(s, y)} \ln s \right) = 0 \quad (4.2.7)$$

$$\sum_{i=1}^2 \left(\partial_y C_i(s, y) (s - y)^{\gamma_i(s, y)} + C_i(s, y) \partial_y \gamma_i(s, y) (s - y)^{\gamma_i(s, y)} \ln(s - y) \right) = 0 \quad (4.2.8)$$

hold, when $a(s, y) < s - y$ and $s < b(s, y)$, respectively, for each $0 < y < s$. Here, the partial derivatives $\partial_s \gamma_i(s, y)$ and $\partial_y \gamma_i(s, y)$ take the form

$$\partial_s \gamma_i(s, y) = \varphi(s, y) - (-1)^i \frac{\varphi(s, y) (\gamma_1(s, y) - \gamma_2(s, y)) \sigma^3(s, y) - 2r \partial_s \sigma(s, y)}{\sigma^2(s, y) \sqrt{(\gamma_1(s, y) - \gamma_2(s, y))^2 \sigma^2(s, y) + 2r}} \quad (4.2.9)$$

$$\partial_y \gamma_i(s, y) = \psi(s, y) - (-1)^i \frac{\psi(s, y) (\gamma_1(s, y) - \gamma_2(s, y)) \sigma^3(s, y) - 2r \partial_y \sigma(s, y)}{\sigma^2(s, y) \sqrt{(\gamma_1(s, y) - \gamma_2(s, y))^2 \sigma^2(s, y) + 2r}} \quad (4.2.10)$$

for $i = 1, 2$, and the functions $\varphi(s, y)$ and $\psi(s, y)$ are defined by

$$\varphi(s, y) = \frac{\sigma(s, y) \partial_s \delta(s, y) + 2(r - \delta(s, y)) \partial_s \sigma(s, y)}{\sigma^3(s, y)} \quad (4.2.11)$$

$$\psi(s, y) = \frac{\sigma(s, y) \partial_y \delta(s, y) + 2(r - \delta(s, y)) \partial_y \sigma(s, y)}{\sigma^3(s, y)} \quad (4.2.12)$$

for $0 < y < s$.

4.2.2. The solution to the problem for the two-dimensional process (X, S) . We begin with the case in which $\delta(s, y) = \delta(s)$ and $\sigma(s, y) = \sigma(s)$ holds in (4.1.1)-(4.1.2), and thus, we can define the functions $\beta_i(s) = \gamma_i(s, y)$, $i = 1, 2$, as in (4.2.2). Then, the general solution $V(x, s, y) = U(x, s)$ of the equation in (4.1.11) has the form of (4.2.1) with $C_i(s, y) = D_i(s)$ and $\gamma_i(s, y) = \beta_i(s)$, for $i = 1, 2$, and the stopping time takes the form of (4.1.6) with the boundaries $a_*(s, y) = g_*(s)$ and $b_*(s, y) = h_*(s)$. We further denote the state space of the two-dimensional (strong) Markov process (X, S) by $E^2 = \{(x, s) \in \mathbb{R}^2 \mid 0 < x \leq s\}$ and its diagonal by $d^2 = \{(x, s) \in \mathbb{R}^2 \mid 0 < x = s\}$, as well as recall that the second component of (X, S) can only increase at d^2 , that is, when $X_t = S_t$ for $t \geq 0$.

(i) The call option. Let us first consider the call option case $L = 0$ in which we have $g_*(s) = 0$ for all $s > 0$. In this case, taking into account the fact that $\beta_2(s) < 0 < 1 < \beta_1(s)$, we observe that $D_2(s) = 0$ should hold in (4.2.1), since otherwise $U(x, s) \rightarrow \pm\infty$ as $x \downarrow 0$, that must be excluded by virtue of the obvious fact that the value function in (4.1.4) is bounded at zero. The same property can equivalently be explained by the fact that the process X cannot reach zero, which is given by the natural boundary condition on the left-hand side of (4.1.19). Hence, solving the system of equations in (4.2.4) and (4.2.6) for the unknown function

$C_1(s, y) = D_1(s)$ with $C_2(s, y) = D_2(s) = 0$, we conclude that the function $V(x, s, y) = U(x, s)$ in (4.2.1) admits the representation

$$U(x, s; h_*(s)) = \frac{h_*(s)}{\beta_1(s)} \left(\frac{x}{h_*(s)} \right)^{\beta_1(s)} \quad \text{with} \quad h_*(s) = \frac{\beta_1(s) K}{\beta_1(s) - 1} \quad (4.2.13)$$

for $0 < x < h_*(s) \leq s$ and $s > K$.

In this case, we set $\tilde{s}_0 = \infty$ and define a decreasing sequence $(\tilde{s}_n)_{n \in \mathbb{N}}$ such that the boundary $h_*(s)$ from (4.2.13) exits the region E^2 at $(\tilde{s}_{2l-1}, \tilde{s}_{2l-1})$ and returns back to E^2 at $(\tilde{s}_{2l}, \tilde{s}_{2l})$ downwards. Namely, we define $\tilde{s}_{2l-1} = \sup\{s < \tilde{s}_{2l-2} \mid h_*(s) > s\}$ and $\tilde{s}_{2l} = \sup\{s < \tilde{s}_{2l-1} \mid h_*(s) \leq s\}$, $l \in \mathbb{N}$, whenever they exist, and put $\tilde{s}_{2l-1} = \tilde{s}_{2l} = 0$ otherwise. Note that $K < \tilde{s}_{2l} < \tilde{s}_{2l-1} < \infty$, $l \in \mathbb{N}$, by construction. Then, the candidate value function admits the representation of (4.2.13) in the regions

$$\tilde{R}_{2l-1}^2 = \{(x, s) \in E^2 \mid \tilde{s}_{2l-1} < s \leq \tilde{s}_{2l-2}\} \quad (4.2.14)$$

for $l \in \mathbb{N}$.

On the other hand, the candidate value function $V(x, s, y) = U(x, s)$ takes the form of (4.2.1) with $C_1(s, y) = D_1(s)$ solving the first-order linear ordinary differential equation in (4.2.7) and $C_2(s, y) = D_2(s) = 0$, in the regions

$$\tilde{R}_{2l}^2 = \{(x, s) \in E^2 \mid \tilde{s}_{2l} < s \leq \tilde{s}_{2l-1}\} \quad (4.2.15)$$

for $l \in \mathbb{N}$, which belong to C' in (4.1.7). Note that, the process (X, S) can pass from the region \tilde{R}_{2l}^2 in (4.2.15) to the region \tilde{R}_{2l-1}^2 in (4.2.14), only through the point $(\tilde{s}_{2l-1}, \tilde{s}_{2l-1})$, for $l \in \mathbb{N}$. Thus, the candidate value function should be continuous at the point $(\tilde{s}_{2l-1}, \tilde{s}_{2l-1})$, that is expressed by the equality

$$D_1(\tilde{s}_{2l-1}) (\tilde{s}_{2l-1})^{\beta_1(\tilde{s}_{2l-1})} = U(\tilde{s}_{2l-1}+, \tilde{s}_{2l-1}+; h_*(\tilde{s}_{2l-1}+)) \quad (4.2.16)$$

where the right-hand side is given by (4.2.13). Hence, solving the first-order linear ordinary differential equation in (4.2.7) for the unknown function $C_1(s, y) = D_1(s)$ with $C_2(s, y) = D_2(s) = 0$ and using the condition of (4.2.16), we obtain that the candidate value function $V(x, s, y) = U(x, s)$ in (4.2.1) admits the expression

$$U(x, s; \tilde{s}_{2l-1}) = \exp \left(- \int_s^{\tilde{s}_{2l-1}} \beta_1'(q) \ln q \, dq \right) \frac{(\tilde{s}_{2l-1})^{1-\beta_1(\tilde{s}_{2l-1})}}{\beta_1(\tilde{s}_{2l-1})} x^{\beta_1(s)} \quad (4.2.17)$$

in the regions \tilde{R}_{2l}^2 given by (4.2.15), for $l \in \mathbb{N}$.

(ii) The put option. Let us now consider the put option case $K = \infty$ in which we have $h_*(s) = \infty$ for all $s > 0$. Then, solving the system of equations in (4.2.3) and (4.2.5) for

the unknown functions $C_i(s, y) = D_i(s)$, $i = 1, 2$, we conclude that the function $V(x, s, y) = U(x, s)$ in (4.2.1) admits the representation

$$U(x, s; g_*(s)) = D_1(s; g_*(s)) x^{\beta_1(s)} + D_2(s; g_*(s)) x^{\beta_2(s)} \quad (4.2.18)$$

for $0 < g_*(s) < x \leq s$, with

$$D_i(s; g_*(s)) = \frac{(\beta_{3-i}(s) - 1) g_*(s) - \beta_{3-i}(s) L}{(\beta_i(s) - \beta_{3-i}(s)) g_*(s)^{\beta_i(s)}} \quad (4.2.19)$$

for all $s > 0$ and $i = 1, 2$. Hence, assuming that the boundary function $g_*(s)$ is continuously differentiable, we apply the condition of (4.2.7) to the functions $C_i(s, y) = D_i(s; g_*(s))$, $i = 1, 2$, in (4.2.19) and obtain that $g_*(s)$ satisfies the first-order nonlinear ordinary differential equation

$$g'(s) = \sum_{i=1}^2 \frac{((\beta_{3-i}(s) - 1) g(s) - \beta_{3-i}(s)) g(s)}{(\beta_i(s) - 1) (\beta_{3-i}(s) - 1) g(s) - \beta_i(s) \beta_{3-i}(s) L} \quad (4.2.20)$$

$$\times \left(\frac{1}{\beta_{3-i}(s) - \beta_i(s)} + \frac{(s/g(s))^{\beta_i(s)} \ln(s/g(s))}{(s/g(s))^{\beta_i(s)} - (s/g(s))^{\beta_{3-i}(s)}} \right) \beta_i'(s)$$

when $0 < g(s) < s$, for $s > 0$, where the derivatives $\beta_i'(s) = \partial_s \gamma_i(s, y)$, $i = 1, 2$, are given by (4.2.9) with (4.2.11). Taking into account the fact that $\beta_i(s)$, $i = 1, 2$, and the boundary $g_*(s)$ are continuously differentiable functions in the neighborhood of infinity, we observe that the function in (4.2.18) should satisfy the property $U(x, s; g_*(s)) \rightarrow U(x, \infty; g_*(\infty))$ as $s \rightarrow \infty$, for each $x > g_*(s)$. Thus, using the fact that $\beta_2(s) < 0 < 1 < \beta_1(s)$, we obtain the expressions

$$U(x, \infty; g_*(\infty)) = \frac{g_*(\infty)}{\beta_2(\infty)} \left(\frac{x}{g_*(\infty)} \right)^{\beta_2(\infty)} \quad \text{and} \quad g_*(\infty) = \frac{\beta_2(\infty) L}{\beta_2(\infty) - 1} \quad (4.2.21)$$

for $x > g_*(\infty)$. The form of the function $U(x, \infty; g_*(\infty))$ and the boundary $g_*(\infty)$ in (4.2.21) follows from the fact that $U(x, \infty; g_*(\infty)) \rightarrow \pm\infty$ should not hold as $x \rightarrow \infty$, since the value function in (4.1.4) is bounded at infinity. Observe that the expressions in (4.2.21) coincide with the ones of the value function in the corresponding continuation region and the exercise boundary of the perpetual American put option in the Black-Merton-Scholes model with constant coefficients (see, e.g. [105; Chapter VIII, Section 2a]).

Let us now consider the *maximal* solution $g_*(s)$ of the first-order ordinary differential equation in (4.2.20) with starting value $g_*(\infty)$ from (4.2.21) as $s \uparrow \infty$, which stays strictly below the line $x = L$, whenever such a solution exists. Let us now put $\widehat{s}_0 = \infty$ and define a decreasing sequence $(\widehat{s}_n)_{n \in \mathbb{N}}$ such that the solution $g_*(s)$ of the equation in (4.2.20) exits the region E^2 at the points $(\widehat{s}_{2k-1}, \widehat{s}_{2k-1})$ and enters E^2 downwards at the points $(\widehat{s}_{2k}, \widehat{s}_{2k})$. Namely, we define $\widehat{s}_{2k-1} = \sup\{s \leq \widehat{s}_{2k-2} \mid g_*(s) > s\}$ and $\widehat{s}_{2k} = \sup\{s \leq \widehat{s}_{2k-1} \mid g_*(s) \leq s\}$, $k \in \mathbb{N}$, whenever they exist, and put $\widehat{s}_{2k} = \widehat{s}_{2k-1} = 0$ otherwise. Note that $0 < \widehat{s}_{2k} < \widehat{s}_{2k-1} < L$, $k \in \mathbb{N}$,

by construction. Then, the candidate value function takes the form of (4.2.18)-(4.2.19) in the regions

$$\widehat{Q}_{2k-1}^2 = \{(x, s) \in E^2 \mid \widehat{s}_{2k-1} < s \leq \widehat{s}_{2k-2}\} \quad (4.2.22)$$

for $k \in \mathbb{N}$ and the boundary function $g_*(s)$ provides the *maximal* solution of the equation in (4.2.20) staying strictly below the level L and satisfying $g_*(\infty)$ given by (4.2.21). Finally, we note that the candidate value function should be given by the condition of (4.1.13) in the regions

$$\widehat{Q}_{2k}^2 = \{(x, s) \in E^2 \mid \widehat{s}_{2k} < s \leq \widehat{s}_{2k-1}\} \quad (4.2.23)$$

for $k \in \mathbb{N}$, which belong to the stopping region D_* in (4.1.9).

(iii) The strangle option. Let us finally consider the strangle option case $0 < L < K < \infty$ in which we have $0 < g_*(s) < h_*(s) < \infty$ for all $s > 0$. Then, solving the system of equations in (4.2.3)-(4.2.4) and (4.2.5)-(4.2.6) for the unknown functions $C_i(s, y) = D_i(s)$, $i = 1, 2$, we conclude that the function $V(x, s, y) = U(x, s)$ in (4.2.1) admits the representation

$$U(x, s; g_*(s), h_*(s)) = D_1(s; g_*(s), h_*(s)) x^{\beta_1(s)} + D_2(s; g_*(s), h_*(s)) x^{\beta_2(s)} \quad (4.2.24)$$

for $0 < g_*(s) < x < h_*(s) \leq s$ and $s > K$, with

$$D_i(s; g_*(s), h_*(s)) = \frac{(L - g_*(s)) h_*^{\beta_{3-i}(s)}(s) - (h_*(s) - K) g_*^{\beta_{3-i}(s)}(s)}{g_*^{\beta_i(s)}(s) h_*^{\beta_{3-i}(s)}(s) - h_*^{\beta_i(s)}(s) g_*^{\beta_{3-i}(s)}(s)} \quad (4.2.25)$$

for all $s > 0$. Here, the boundaries $g_*(s)$ and $h_*(s)$ provide a unique solution to the system of algebraic equations

$$I_1(g(s); s) = J_1(h(s); s) \quad \text{and} \quad I_2(g(s); s) = J_2(h(s); s) \quad (4.2.26)$$

for all $s > K$, where the functions $I_i(x; s)$ and $J_i(x; s)$ are defined by the expressions

$$I_i(x; s) = \frac{(1 - \beta_{3-i}(s)) x + \beta_{3-i}(s) L}{(-1)^i x^{\beta_i(s)}} \quad \text{and} \quad J_i(x; s) = \frac{(\beta_{3-i}(s) - 1) x - \beta_{3-i}(s) K}{(-1)^i x^{\beta_i(s)}} \quad (4.2.27)$$

for all $0 < x \leq s$ and $i = 1, 2$, and the uniqueness of the solution of the system in (4.2.26) is proved in [47; Section 4].

Let us put $\widetilde{s}_0 = \infty$ and consider the decreasing sequence $(\widetilde{s}_n)_{n \in \mathbb{N}}$ as in part (i) above which is now associated with $h_*(s)$ as a solution of the system in (4.2.26). Then, the candidate value function takes the form of (4.2.24)-(4.2.25) and the boundaries $g_*(s)$ and $h_*(s)$ provide the unique solution of the system of equations in (4.2.26) in the regions \widetilde{R}_{2l-1}^2 , for $l = 1, \dots, \widetilde{l}$, given by (4.2.14), where we put $\widetilde{l} = \sup\{l \in \mathbb{N} \mid \widetilde{s}_{2l-1} > K\}$. Moreover, we put $\widehat{s}_0 = \widetilde{s}_{2\widetilde{l}-1}$ and consider the decreasing sequence $(\widehat{s}_n)_{n \in \mathbb{N}}$ as in part (ii) above. Then, the candidate value function admits the representation in (4.2.18)-(4.2.19) in the regions \widetilde{R}_{2l}^2 , for $l = 1, \dots, \widetilde{l}$, or

\widehat{Q}_{2k-1}^2 , for $k \in \mathbb{N}$, given by (4.2.15) and (4.2.22), respectively, and the boundary $g_*(s)$ provides a unique solution of the equation in (4.2.20) with starting value $g_*(\widetilde{s}_{2l-1})$ in each region \widetilde{R}_{2l}^2 , for $l = 1, \dots, \widetilde{l}-1$, and $g_*(\widetilde{s}_{2\widetilde{l}-1})$ in all \widehat{Q}_{2k-1}^2 , for $k \in \mathbb{N}$. The value of $g_*(\widetilde{s}_{2l-1})$ is given by $g(\widetilde{s}_{2l-1})$ from the solution of (4.2.26), for $l = 1, \dots, \widetilde{l}$. To see this, observe that the process (X, S) can move from the region \widetilde{R}_{2l}^2 in (4.2.15) to the region \widetilde{R}_{2l-1}^2 in (4.2.14), for $l = 1, \dots, \widetilde{l}-1$ and from \widehat{Q}_1^2 to $\widetilde{R}_{2\widetilde{l}-1}^2$ only through the point $(\widetilde{s}_{2l-1}, \widetilde{s}_{2l-1})$, for $l = 1, \dots, \widetilde{l}$, respectively, and the candidate value function is continuous at the point $(\widetilde{s}_{2l-1}, \widetilde{s}_{2l-1})$, satisfying

$$U(\widetilde{s}_{2l-1}, \widetilde{s}_{2l-1}; g_*(\widetilde{s}_{2l-1})) = U(\widetilde{s}_{2l-1}+, \widetilde{s}_{2l-1}+; g_*(\widetilde{s}_{2l-1}+), h_*(\widetilde{s}_{2l-1}+)) \equiv (\widetilde{s}_{2l-1} - K)+ \quad (4.2.28)$$

where the left-hand side is given by (4.2.18)-(4.2.19) with $g_*(\widetilde{s}_{2l-1})$ from the solution of (4.2.26), for every $l = 1, \dots, \widetilde{l}$.

4.2.3. The solution to the problem for the three-dimensional process (X, S, Y) .

We now continue with the general form of the coefficients $\delta(s, y)$ and $\sigma(s, y)$ in (4.1.1)-(4.1.2), and thus, of the functions $\gamma_i(s, y)$, $i = 1, 2$, from (4.2.2). We denote the border planes of the state space E^3 by $d_1^3 = \{(x, s, y) \in \mathbb{R}^3 \mid 0 < x = s\}$ and $d_2^3 = \{(x, s, y) \in \mathbb{R}^3 \mid 0 < x = s - y\}$, as well as recall that the second and third components of the process (X, S, Y) can increase only at the planes d_1^3 and d_2^3 , that is, when $X_t = S_t$ and $X_t = S_t - Y_t$ for $t \geq 0$, respectively.

(i) The call option. Let us first consider the case of the standard call option $L = 0$ in which we have $a_*(s, y) = 0$ for all $0 < y < s$. Then, solving the system of equations in (4.2.4) and (4.2.6), we conclude that the function in (4.2.1) admits the representation

$$V(x, s, y; b_*(s, y)) = C_1(s, y; b_*(s, y)) x^{\gamma_1(s, y)} + C_2(s, y; b_*(s, y)) x^{\gamma_2(s, y)} \quad (4.2.29)$$

for $0 < s - y \leq x < b_*(s, y) \leq s$ and $s > K$, with

$$C_i(s, y; b_*(s, y)) = \frac{(\gamma_{3-i}(s, y) - 1) b_*(s, y) - \gamma_{3-i}(s, y) K}{(\gamma_{3-i}(s, y) - \gamma_i(s, y)) b_*(s, y)^{\gamma_i(s, y)}} \quad (4.2.30)$$

for all $0 < y < s$ and $i = 1, 2$. Hence, assuming that the boundary function $b_*(s, y)$ is continuously differentiable, we apply the condition of (4.2.8) to the functions $C_i(s, y) = C_i(s, y; b_*(s, y))$, $i = 1, 2$, in (4.2.30) to obtain that $b_*(s, y)$ solves the first-order nonlinear ordinary differential equation

$$\begin{aligned} \partial_y b(s, y) &= \sum_{i=1}^2 \frac{((\gamma_{3-i}(s, y) - 1) b(s, y) - \gamma_{3-i}(s, y) K) b(s, y)}{(\gamma_i(s, y) - 1) (\gamma_{3-i}(s, y) - 1) b(s, y) - \gamma_i(s, y) \gamma_{3-i}(s, y) K} \\ &\times \left(\frac{1}{\gamma_{3-i}(s, y) - \gamma_i(s, y)} + \frac{((s - y)/b(s, y))^{\gamma_i(s, y)} \ln((s - y)/b(s, y))}{((s - y)/b(s, y))^{\gamma_i(s, y)} - ((s - y)/b(s, y))^{\gamma_{3-i}(s, y)}} \right) \partial_y \gamma_i(s, y) \end{aligned} \quad (4.2.31)$$

for $0 < y < s$, where the partial derivatives $\partial_y \gamma_i(s, y)$, $i = 1, 2$, are given by (4.2.10) with (4.2.12).

Since the functions $\delta(s, y)$ and $\sigma(s, y)$ are assumed to be continuously differentiable and bounded, it follows that the limits $\delta(s, s-)$ and $\sigma(s, s-)$ exist for each $s > 0$. Then, the limits $\gamma_i(s, s-)$ can be identified with the functions $\beta_i(s)$, $i = 1, 2$, from Subsection 3.2 above, and the function in (4.2.29) should satisfy the property $V(x, s, y; b_*(s, y)) \rightarrow V(x, s, s-; b_*(s, s-))$ as $y \uparrow s$, for each $s - y \leq x < b_*(s, y)$. Thus, taking into account the fact that $\gamma_2(s, y) < 0 < 1 < \gamma_1(s, y)$, we conclude that the equalities

$$V(x, s, s-; b_*(s, s-)) = U(x, s; b_*(s, s-)) \quad \text{and} \quad b_*(s, s-) = h_*(s) \quad (4.2.32)$$

hold for $0 < x < b_*(s, s-)$ and $s > K$, with $U(x, s; h_*(s))$ and $h_*(s)$ given by (4.2.13), since otherwise $V(x, s, s-; b_*(s, s-)) \rightarrow \pm\infty$ as $x \downarrow 0$, that must be excluded by virtue of the obvious fact that the value function in (4.1.4) is bounded at zero.

For any $s > K$ fixed, let us now consider the solution $b_*(s, y)$ of (4.2.31) started from the value $h_*(s)$ given by (4.2.13) at $y \uparrow s$. Then, we put $\tilde{y}_0(s) = s$ and define a decreasing sequence $(\tilde{y}_n(s))_{n \in \mathbb{N}}$ such that $\tilde{y}_{2l-1}(s) = \sup\{y < \tilde{y}_{2l-2}(s) \mid b_*(s, y) > s\}$ and $\tilde{y}_{2l}(s) = \sup\{y < \tilde{y}_{2l-1}(s) \mid b_*(s, y) \leq s\}$, whenever they exist, and put $\tilde{y}_{2l-1}(s) = \tilde{y}_{2l}(s) = 0$, $l \in \mathbb{N}$, otherwise. Moreover, we can also define a decreasing sequence $(\hat{y}_n(s))_{n \in \mathbb{N}}$ such that the boundary $b_*(s, y)$ exits the region E^3 from the side of d_2^3 at the points $(s - \hat{y}_{2k-1}(s), s, \hat{y}_{2k-1}(s))$ and enters E^3 downwards at the points $(s - \hat{y}_{2k}(s), s, \hat{y}_{2k}(s))$. Namely, we put $\hat{y}_0(s) = s$ and define $\hat{y}_{2k-1}(s) = \sup\{y < \hat{y}_{2k-2}(s) \mid b_*(s, y) < s - y\}$ and $\hat{y}_{2k}(s) = \sup\{y < \hat{y}_{2k-1}(s) \mid b_*(s, y) \geq s - y\}$, whenever such points exist, and put $\hat{y}_{2k-1}(s) = \hat{y}_{2k}(s) = 0$ otherwise, for $k \in \mathbb{N}$. Note that $0 < \hat{y}_{2k}(s) < \hat{y}_{2k-1}(s) < s - K$, $k \in \mathbb{N}$, by construction. Therefore, the candidate value function admits the expression in (4.2.29)-(4.2.30) in either the region

$$\tilde{R}_{2l-1}^3 = \{(x, s, y) \in E^3 \mid \tilde{y}_{2l-1}(s) < y \leq \min_{k \in \mathbb{N}} \{\hat{y}_{2k-2}(s) \mid \tilde{y}_{2l-1}(s) < \hat{y}_{2k-2}(s)\} \wedge \tilde{y}_{2l-2}(s)\} \quad (4.2.33)$$

or

$$\hat{R}_{2k-1}^3 = \{(x, s, y) \in E^3 \mid \hat{y}_{2k-1}(s) < y \leq \min_{l \in \mathbb{N}} \{\tilde{y}_{2l-1}(s) \mid \tilde{y}_{2l-1}(s) < \hat{y}_{2k-2}(s)\} \wedge \hat{y}_{2k-2}(s)\} \quad (4.2.34)$$

for $k, l \in \mathbb{N}$, and the boundary $b_*(s, y)$ provides the unique solution of the equation in (4.2.31) started from the value $b_*(s, s-) = h_*(s)$ from (4.2.13) (see Figure 3 below).

On the other hand, the candidate value function takes the form of (4.2.1) with $C_i(s, y)$, $i = 1, 2$, solving the linear system of first-order partial differential equations in (4.2.7) and (4.2.8), in the regions

$$\tilde{R}_{2l}^3 = \{(x, s, y) \in E^3 \mid \tilde{y}_{2l}(s) < y \leq \tilde{y}_{2l-1}(s)\} \quad (4.2.35)$$

for $l \in \mathbb{N}$, which belong to C' in (4.1.7). Note that, the process (X, S, Y) can enter the region \tilde{R}_{2l}^3 in (4.2.35) from one of the regions \tilde{R}_{2l+1}^3 in (4.2.33) or \hat{R}_{2k-1}^3 in (4.2.34), for some $k \in \mathbb{N}$, only through the point $(s - \tilde{y}_{2l}(s), s, \tilde{y}_{2l}(s))$ and can exit the region \tilde{R}_{2l}^3 passing to the

region \tilde{R}_{2l-1}^3 only through the point $(s - \tilde{y}_{2l-1}(s), s, \tilde{y}_{2l-1}(s))$, by hitting the plane d_2^3 , so that increasing its third component Y . Thus, the candidate function should be continuous at the points $(s - \tilde{y}_{2l}(s), s, \tilde{y}_{2l}(s))$ and $(s - \tilde{y}_{2l-1}(s), s, \tilde{y}_{2l-1}(s))$, that is expressed by the equalities

$$\begin{aligned} & C_1(s, \tilde{y}_{2l}(s)+) ((s - \tilde{y}_{2l}(s)) -)^{\gamma_1(s, \tilde{y}_{2l}(s)+)} + C_2(s, \tilde{y}_{2l}(s)+) ((s - \tilde{y}_{2l}(s)) -)^{\gamma_2(s, \tilde{y}_{2l}(s)+)} \quad (4.2.36) \\ & = V(s - \tilde{y}_{2k}(s), s, \tilde{y}_{2k}(s); b(s, \tilde{y}_{2k}(s))) \end{aligned}$$

$$\begin{aligned} & C_1(s, \tilde{y}_{2l-1}(s)) (s - \tilde{y}_{2l-1}(s))^{\gamma_1(s, \tilde{y}_{2l-1}(s))} + C_2(s, \tilde{y}_{2l-1}(s)) (s - \tilde{y}_{2l-1}(s))^{\gamma_2(s, \tilde{y}_{2l-1}(s))} \quad (4.2.37) \\ & = V((s - \tilde{y}_{2k-1}(s)) - , s, \tilde{y}_{2k-1}(s)+; b_*(s, \tilde{y}_{2k-1}(s)+)) \end{aligned}$$

for $s > K$ and $l \in \mathbb{N}$, where the right-hand sides are given by (4.2.29)-(4.2.30) with $b_*(s, \tilde{y}_{2k-1}(s)+) = b_*(s, \tilde{y}_{2k}(s)) = s$. However, if $b_*(s, s-) = h_*(s) > s$ holds with $h_*(s)$ given by (4.2.13), then we have $\tilde{y}_1(s) = s-$ and the condition of (4.2.37) for $l = 1$, changes its form to $C_2(s, s-) = 0$ for $s > K$, since otherwise $V(x, s, y) \rightarrow \pm\infty$ as $x \downarrow 0$, that must be excluded by virtue of the obvious fact that the value function in (4.1.4) is bounded at zero.

In addition, the process (X, S, Y) can exit the region \tilde{R}_{2l}^3 in (4.2.35) passing to the stopping region D_* from (4.1.9) only through the point $(\bar{s}(y), \bar{s}(y), y)$, by hitting the plane d_1^3 , so that increasing its second component S until it reaches the value $\bar{s}(y) = \inf\{q > s \mid b_*(q, y) \leq q\}$. Since the boundary $b_*(q, y)$ provides a solution of the equation in (4.2.31) with starting value $b_*(q, q-) = h_*(q)$, for each $q \leq \bar{s}(y)$, the candidate value function should be continuous at the point $(\bar{s}(y), \bar{s}(y), y)$, that is expressed by the equality

$$\begin{aligned} & C_1(\bar{s}(y)-, y) (\bar{s}(y)-)^{\gamma_1(\bar{s}(y)-, y)} + C_2(\bar{s}(y)-, y) (\bar{s}(y)-)^{\gamma_2(\bar{s}(y)-, y)} \quad (4.2.38) \\ & = V(\bar{s}(y), \bar{s}(y), y; b_*(\bar{s}(y), y)) \equiv \bar{s}(y) - K \end{aligned}$$

We can therefore conclude that the candidate value function admits the representation

$$\begin{aligned} & V(x, s, y; \bar{s}(y), \tilde{y}_{2l-1}(s), \tilde{y}_{2l}(s)) \quad (4.2.39) \\ & = C_1(s, y; \bar{s}(y), \tilde{y}_{2l-1}(s), \tilde{y}_{2l}(s)) x^{\gamma_1(s, y)} + C_2(s, y; \bar{s}(y), \tilde{y}_{2l-1}(s), \tilde{y}_{2l}(s)) x^{\gamma_2(s, y)} \end{aligned}$$

in the regions \tilde{R}_{2l}^3 given by (4.2.35), where $C_i(s, y; \bar{s}(y), \tilde{y}_{2l-1}(s), \tilde{y}_{2l}(s))$, $i = 1, 2$, provide a unique solution of the two-dimensional system of first-order linear partial differential equations in (4.2.7)-(4.2.8) with the boundary conditions of (4.2.36)-(4.2.38), for $l \in \mathbb{N}$. Finally, we observe that the candidate value function should be given by the condition of (4.1.13) in the regions

$$\hat{R}_{2k}^3 = \{(x, s, y) \in E^3 \mid \hat{y}_{2k}(s) < y \leq \hat{y}_{2k-1}(s)\} \quad (4.2.40)$$

for $k \in \mathbb{N}$, which belongs to the stopping region D_* in (4.1.9).

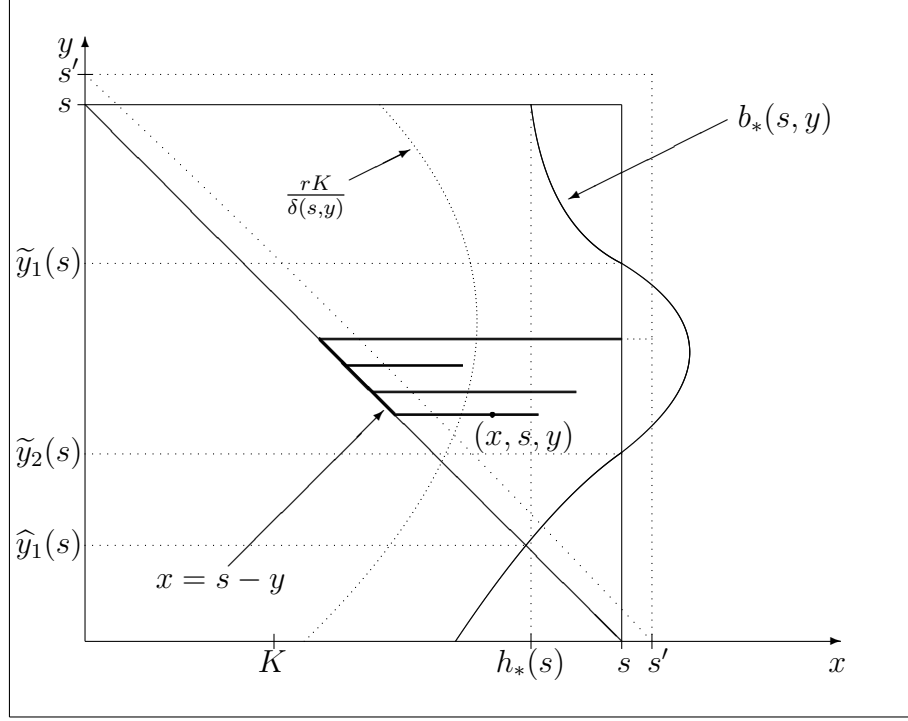

Figure 3. A computer drawing of the state space of the process (X, S, Y) , for some s fixed, which increases to s' , and the boundary function $b_*(s, y)$.

(ii) **The put option.** Let us now consider the case of standard put option $K = \infty$ in which we have $b_*(s, y) = \infty$ for all $0 < y < s$. Then, solving the system of equations in (4.2.3) and (4.2.5), we conclude that the function in (4.2.1) admits the representation

$$V(x, s, y; a_*(s, y)) = C_1(s, y; a_*(s, y)) x^{\gamma_1(s, y)} + C_2(s, y; a_*(s, y)) x^{\gamma_2(s, y)} \quad (4.2.41)$$

for $0 < s - y \leq a_*(s, y) < x \leq s$, with

$$C_i(s, y; a_*(s, y)) = \frac{(\gamma_{3-i}(s, y) - 1) a_*(s, y) - \gamma_{3-i}(s, y) L}{(\gamma_i(s, y) - \gamma_{3-i}(s, y)) a_*^{\gamma_i(s, y)}(s, y)} \quad (4.2.42)$$

for all $0 < y < s$ and $i = 1, 2$. Hence, assuming that the boundary function $a_*(s, y)$ is continuously differentiable, we apply the condition of (4.2.7) for the functions $C_i(s, y) = C_i(s, y; a_*(s, y))$, $i = 1, 2$, in (4.2.42) to obtain that $a_*(s, y)$ solves the first-order nonlinear ordinary differential equation

$$\begin{aligned} \partial_s a(s, y) = & \sum_{i=1}^2 \frac{((\gamma_{3-i}(s, y) - 1) a(s, y) - \gamma_{3-i}(s, y)) a(s, y)}{(\gamma_i(s, y) - 1) (\gamma_{3-i}(s, y) - 1) a(s, y) - \gamma_i(s, y) \gamma_{3-i}(s, y) L} \\ & \times \left(\frac{1}{\gamma_{3-i}(s, y) - \gamma_i(s, y)} + \frac{(s/a(s, y))^{\gamma_i(s, y)} \ln(s/a(s, y))}{(s/a(s, y))^{\gamma_i(s, y)} - (s/a(s, y))^{\gamma_{3-i}(s, y)}} \right) \partial_s \gamma_i(s, y) \end{aligned} \quad (4.2.43)$$

for $0 < y < s$, where the partial derivatives $\partial_s \gamma_i(s, y)$, $i = 1, 2$, are given by (4.2.9) with (4.2.11).

Since the functions $\delta(s, y)$ and $\sigma(s, y)$ are assumed to be continuously differentiable and bounded, the limits $\delta(y+, y)$ and $\sigma(y+, y)$ exist for each $y > 0$. Then, the limits $\gamma_i(y+, y)$ can be identified with the functions $\beta_i(y)$, for $i = 1, 2$, from Subsection 3.2 above, and the function in (4.2.41) should satisfy the property $V(x, s, y; a_*(s, y)) \rightarrow V(x, y+, y; a_*(y+, y))$ as $s \downarrow y$, for each $s - y \leq a_*(s, y) < x \leq s$. Thus, we conclude that the equalities

$$V(x, y+, y; a_*(y+, y)) = U(x, y; a_*(y+, y)) \quad \text{and} \quad a_*(y+, y) = g_*(y) \quad (4.2.44)$$

hold for $0 < a_*(y+, y) < x \leq y$ and $U(x, s; g_*(s))$ given by (4.2.18) with $g_*(s)$ obtained in part (ii) of Subsection 3.2. To see this, we observe that the candidate value function evaluated at $s \downarrow y$ in (4.2.44) satisfies the normal reflection condition only at the diagonal $d_3^3 = \{(x, s, y) \in \mathbb{R}^3 \mid 0 < x = s = y\}$ of the plane d_1^3 , and thus, the function $a_*(y+, y) = g_*(y)$ is the *maximal* solution of the equation in (4.2.20) with the boundary condition $a_*(\infty, \infty) = g_*(\infty)$ of (4.2.21) as $y = s \rightarrow \infty$, which stays strictly below the plane $x = L$.

For any $y > 0$ fixed, let us now consider the solution $a_*(s, y)$ of (4.2.43) started from the value $a_*(y+, y) = g_*(y)$, which is the *maximal* solution of (4.2.20) satisfying $a_*(\infty, \infty) = g_*(\infty)$ from (4.2.21) and staying strictly below L , whenever such a solution exists. Then, we put $\tilde{s}_0(y) = y$ and define an increasing sequence $(\tilde{s}_n(y))_{n \in \mathbb{N}}$ such that the boundary $a_*(s, y)$ exits the region E^3 from the side of the plane d_1^3 at the points $(\tilde{s}_{2l-1}(y), \tilde{s}_{2l-1}(y), y)$ and enters E^3 upwards at the points $(\tilde{s}_{2l}(y), \tilde{s}_{2l}(y), y)$. Namely, we define $\tilde{s}_{2l-1}(y) = \inf\{s > \tilde{s}_{2l-2}(y) \mid a_*(s, y) > s\}$ and $\tilde{s}_{2l}(y) = \inf\{s > \tilde{s}_{2l-1}(y) \mid a_*(s, y) \leq s\}$, $l \in \mathbb{N}$, whenever they exist, and put $\tilde{s}_{2l-1}(y) = \tilde{s}_{2l}(y) = \infty$ otherwise, for $l \in \mathbb{N}$. Note that $y < \tilde{s}_{2l-1}(y) < \tilde{s}_{2l}(y) \leq L$, $l \in \mathbb{N}$, by construction. Moreover, we put $\hat{s}_0(y) = y$ and define an increasing sequence $(\hat{s}_n(y))_{n \in \mathbb{N}}$ such that $\hat{s}_{2k-1}(y) = \inf\{s > \hat{s}_{2k-2}(y) \mid a_*(s, y) < s - y\}$ and $\hat{s}_{2k}(y) = \inf\{s > \hat{s}_{2k-1}(y) \mid a_*(s, y) \geq s - y\}$, $k \in \mathbb{N}$, whenever they exist, and put $\hat{s}_{2k-1}(y) = \hat{s}_{2k}(y) = \infty$ otherwise. Note that $y \leq \hat{s}_{2k-2}(y) < \hat{s}_{2k-1}(y) < L + y$, by construction, for $k = 1, \dots, \hat{k}$, where $\hat{k} = \sup\{k \in \mathbb{N} \mid \hat{s}_{2k-1}(y) < L + y\}$. Therefore, the candidate value function admits the expression in (4.2.41) in either the region

$$\hat{Q}_{2k-2}^3 = \{(x, s, y) \in E^3 \mid \hat{s}_{2k-2}(y) \leq s < \min_{l \in \mathbb{N}} \{\tilde{s}_{2l-1}(y) \mid \tilde{s}_{2l-1}(y) > \hat{s}_{2k-2}(y)\} \wedge \hat{s}_{2k-1}(y)\} \quad (4.2.45)$$

or

$$\tilde{Q}_{2l-2}^3 = \{(x, s, y) \in E^3 \mid \tilde{s}_{2l-2}(y) \leq y < \min_{k \in \mathbb{N}} \{\hat{s}_{2k-1}(y) \mid \hat{s}_{2k-1}(y) > \tilde{s}_{2l-2}(y)\} \wedge \tilde{s}_{2l-1}(y)\} \quad (4.2.46)$$

for $k = 1, \dots, \hat{k}$ and $l \in \mathbb{N}$, and the boundary function $a_*(s, y)$ provides the unique solution of (4.2.43) starting from the value $a_*(y+, y) = g_*(y)$, which is the *maximal* solution of (4.2.20) satisfying $a_*(\infty, \infty) = g_*(\infty)$ from (4.2.21) and staying strictly below L (see Figure 4 below).

On the other hand, the candidate value function takes the form of (4.2.1) with $C_i(s, y)$, $i = 1, 2$, solving the linear system of first-order partial differential equations in (4.2.7) and

(4.2.8), in the regions

$$\widehat{Q}_{2k-1}^3 = \{(x, s, y) \in E^3 \mid \widehat{s}_{2k-1}(y) \leq s < \widehat{s}_{2k}(y)\} \quad (4.2.47)$$

for $k = 1, \dots, \widehat{k}$, which belong to C' in (4.1.7). Note that, the process (X, S, Y) can enter \widehat{Q}_{2k-1}^3 in (4.2.47) from one of the regions \widehat{Q}_{2k-2}^3 in (4.2.45) or \widehat{Q}_{2l-2}^3 in (4.2.46), for some $l \in \mathbb{N}$, only through the point $(\widehat{s}_{2k-1}(y), \widehat{s}_{2k-1}(y), y)$ and can exit \widehat{Q}_{2k-1}^3 passing to \widehat{Q}_{2k}^3 only through the point $(\widehat{s}_{2k}(y), \widehat{s}_{2k}(y), y)$, by hitting the plane d_1^3 and increasing its second component S . Thus, the candidate value function should be continuous at the points $(\widehat{s}_{2k-1}(y), \widehat{s}_{2k-1}(y), y)$ and $(\widehat{s}_{2k}(y), \widehat{s}_{2k}(y), y)$, that is expressed by the equalities

$$\begin{aligned} C_1(\widehat{s}_{2k-1}(y), y) (\widehat{s}_{2k-1}(y))^{\gamma_1(\widehat{s}_{2k-1}(y), y)} + C_2(\widehat{s}_{2k-1}(y), y) (\widehat{s}_{2k-1}(y))^{\gamma_2(\widehat{s}_{2k-1}(y), y)} \\ = V(\widehat{s}_{2k-1}(y)-, \widehat{s}_{2k-1}(y)-, y; a_*(\widehat{s}_{2k-1}(y)-, y)) \end{aligned} \quad (4.2.48)$$

$$\begin{aligned} C_1(\widehat{s}_{2k}(y)-, y) (\widehat{s}_{2k}(y)-)^{\gamma_1(\widehat{s}_{2k}(y)-, y)} + C_2(\widehat{s}_{2k}(y)-, y) (\widehat{s}_{2k}(y)-)^{\gamma_2(\widehat{s}_{2k}(y)-, y)} \\ = V(\widehat{s}_{2k}(y), \widehat{s}_{2k}(y), y; a_*(\widehat{s}_{2k}(y), y)) \end{aligned} \quad (4.2.49)$$

for $y > 0$ and $k = 1, \dots, \widehat{k} - 1$, where the right-hand sides are given by (4.2.41)-(4.2.42) with $a_*(\widehat{s}_{2k-1}(y)-, y) = (\widehat{s}_{2k-1}(y) - y) -$ and $a_*(\widehat{s}_{2k}(y), y) = \widehat{s}_{2k}(y) - y$, respectively. However, in the region $\widehat{Q}_{2\widehat{k}-1}^3$ we have $\widehat{s}_{2\widehat{k}}(y) = \infty$ and the condition of (4.2.49), for $k = \widehat{k}$, changes its form to $C_1(\infty, y) = 0$ for $y > 0$, since otherwise $V(x, \infty, y) \rightarrow \pm\infty$ as $x \uparrow \infty$, that must be excluded due to the fact that the value function in (4.1.4) is bounded at infinity, while the condition of (4.2.48) holds for $k = \widehat{k}$ as well.

In addition, the process (X, S, Y) can exit \widehat{Q}_{2k-1}^3 in (4.2.47) passing to the stopping region D_* in (4.1.9), only through the point $(s - \bar{y}(s), s, \bar{y}(s))$, by hitting the plane d_2^3 , so that increasing its third component Y until it reaches the value $\bar{y}(s) = \inf\{z > y \mid a_*(s, z) \geq s - z\}$. Since the boundary $a_*(s, z)$ provides a solution of the equation in (4.2.43) with starting value $a_*(z+, z) = g_*(z)$ from (4.2.20), for each $z < \bar{y}(s)$, the candidate value function should be continuous at the point $(s - \bar{y}(s), s, \bar{y}(s))$, that is expressed by the equality

$$\begin{aligned} C_1(s, \bar{y}(s)-) ((s - \bar{y}(s))+)^{\gamma_1(s, \bar{y}(s)-)} + C_2(s, \bar{y}(s)-) ((s - \bar{y}(s))+)^{\gamma_2(s, \bar{y}(s)-)} \\ = V(s - \bar{y}(s), s, \bar{y}(s); a_*(s, \bar{y}(s))) \equiv L - (s - \bar{y}(s)) \end{aligned} \quad (4.2.50)$$

We can therefore conclude that the candidate value function admits the representation

$$\begin{aligned} V(x, s, y; \widehat{s}_{2k-1}(y), \widehat{s}_{2k}(y), \bar{y}(s)) \\ = C_1(s, y; \widehat{s}_{2k-1}(y), \widehat{s}_{2k}(y), \bar{y}(s)) x^{\gamma_1(s, y)} + C_2(s, y; \widehat{s}_{2k-1}(y), \widehat{s}_{2k}(y), \bar{y}(s)) x^{\gamma_2(s, y)} \end{aligned} \quad (4.2.51)$$

in the regions \widehat{Q}_{2k-1}^3 in (4.2.47), where $C_i(s, y; \widehat{s}_{2k-1}(y), \widehat{s}_{2k}(y), \bar{y}(s))$, $i = 1, 2$, provide a unique solution of the two-dimensional system of linear partial differential equations in (4.2.7)-(4.2.8)

with the boundary conditions (4.2.48)-(4.2.50), for $k = 1, \dots, \widehat{k}$. Finally, we note that the candidate value function should be given by the condition of (4.1.13) in the regions

$$\widetilde{Q}_{2l-1}^3 = \{(x, s, y) \in E^3 \mid \widetilde{s}_{2l-1}(y) \leq s < \widetilde{s}_{2l}(y)\} \quad (4.2.52)$$

for $l \in \mathbb{N}$, which belong to the stopping region D_* from (4.1.9).

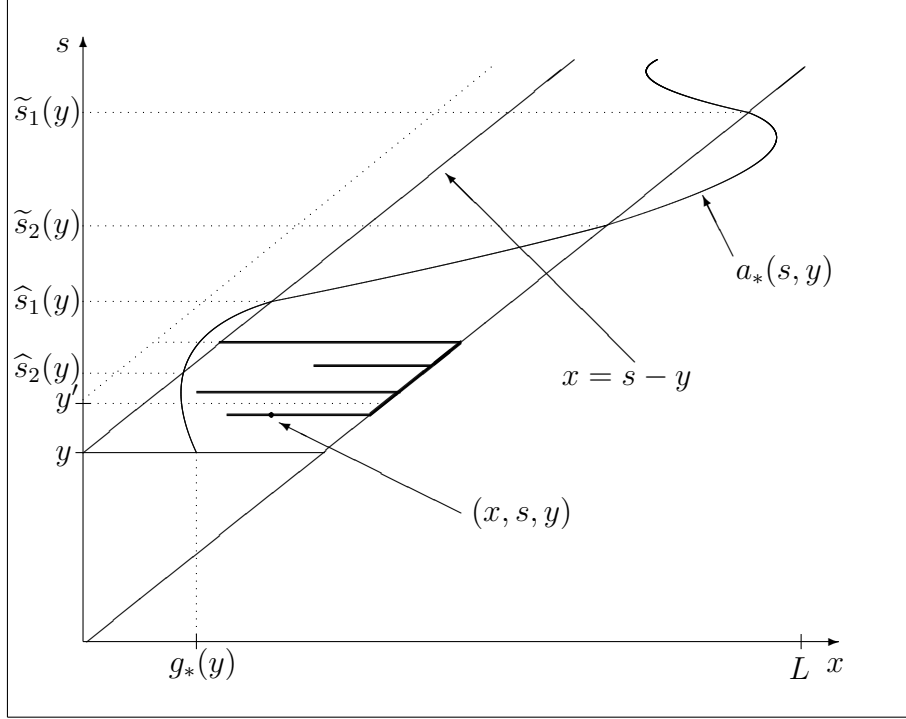

Figure 4. A computer drawing of the state space of the process (X, S, Y) , for some y fixed, which increases to y' , and the boundary function $a_*(s, y)$.

4.3. Main results and proof

In this section, we formulate and prove the main results of the chapter, using the facts proved above. We recall that the process (X, S, Y) is given by (4.1.1)-(4.1.3).

Proposition 4.3.1 *In the perpetual American call option case $L = 0$, the value function of the optimal stopping problem (4.1.4) has the expression*

$$V_*(x, s, y) = \begin{cases} V(x, s, y; b_*(s, y)), & \text{if } s - y \leq x < b_*(s, y) \leq s \\ V(x, s, y; \bar{s}(y), \widetilde{y}_{2l-1}(s), \widetilde{y}_{2l}(s)), & \text{if } s - y \leq x \leq s < b_*(s, y) \\ x - K, & \text{if } b_*(s, y) \leq x \leq s \end{cases} \quad (4.3.1)$$

and the optimal stopping time is given by (4.1.6) with $a_*(s, y) = 0$, where the functions $V(x, s, y; b_*(s, y))$ and $V(x, s, y; \bar{s}(y), \tilde{y}_{2l-1}(s), \tilde{y}_{2l}(s))$ as well as the boundary $b_*(s, y)$ are specified as follows:

(i) in the particular case $\delta(s, y) = \delta(s)$ and $\sigma(s, y) = \sigma(s)$, the function $V(x, s, y; b_*(s, y)) = U(x, s; h_*(s))$ and the boundary $b_*(s, y) = h_*(s)$ are given by (4.2.13), for $(x, s) \in \tilde{R}_{2l-1}^2$ defined in (4.2.14), and $V(x, s, y; \bar{s}(y), \tilde{y}_{2l-1}(s), \tilde{y}_{2l}(s)) = U(x, s; \tilde{s}_{2l-1})$ is given by (4.2.17), whenever $(x, s) \in \tilde{R}_{2l}^2$ defined in (4.2.15), for $l \in \mathbb{N}$;

(ii) in the general case for $\delta(s, y)$ and $\sigma(s, y)$, the function $V(x, s, y; b_*(s, y))$ is given by (4.2.29)-(4.2.30) and the boundary $b_*(s, y)$ provides the unique solution of the equation in (4.2.31) started from the value $b_*(s, s-) = h_*(s)$ from (4.2.13), for $(x, s, y) \in \tilde{R}_{2l-1}^3 \cup \hat{R}_{2k-1}^3$ defined in (4.2.33) and (4.2.34), respectively, and $V(x, s, y; \bar{s}(y), \tilde{y}_{2l-1}(s), \tilde{y}_{2l}(s))$ is given by (4.2.39), whenever $(x, s, y) \in \tilde{R}_{2l}^3$ defined in (4.2.35), with $C_i(s, y; \bar{s}(y), \tilde{y}_{2l-1}(s), \tilde{y}_{2l}(s))$, $i = 1, 2$, solving the system of equations in (4.2.7)-(4.2.8) and satisfying the conditions of (4.2.36)-(4.2.38), for $k, l \in \mathbb{N}$, where (4.2.37) changes its form to $C_2(s, s-) = 0$, for the case $l = 1$, if $b_*(s, s-) = h_*(s) > s$ holds.

Proposition 4.3.2 *In the perpetual American put option case $K = \infty$, the value function of the optimal stopping problem (4.1.4) has the expression*

$$V_*(x, s, y) = \begin{cases} V(x, s, y; a_*(s, y)), & \text{if } s - y \leq a_*(s, y) < x \leq s \\ V(x, s, y; \hat{s}_{2k-1}(y), \hat{s}_{2k}(y), \bar{y}(s)), & \text{if } a_*(s, y) < s - y \leq x \leq s \\ L - x, & \text{if } s - y \leq x \leq a_*(s, y) \end{cases} \quad (4.3.2)$$

and the optimal stopping time is given by (4.1.6) with $b_*(s, y) = \infty$, where the functions $V(x, s, y; a_*(s, y))$ and $V(x, s, y; \tilde{s}_{2l-1}(y), \tilde{s}_{2l}(y), \bar{y}(s))$ as well as the boundary $a_*(s, y)$ are specified as follows:

(i) in the particular case $\delta(s, y) = \delta(s)$ and $\sigma(s, y) = \sigma(s)$, the function $V(x, s, y; a_*(s, y)) = U(x, s; g_*(s))$ is given by (4.2.18)-(4.2.19) and the boundary $a_*(s, y) = g_*(s)$ provides the maximal solution of the equation in (4.2.20) started at $g_*(\infty)$ from (4.2.21) and staying strictly below the line $x = L$, whenever such a solution exists, for $(x, s) \in \hat{Q}_{2k-1}^2$ defined in (4.2.22) and $k \in \mathbb{N}$;

(ii) in the general case for $\delta(s, y)$ and $\sigma(s, y)$, the function $V(x, s, y; a_*(s, y))$ is given by (4.2.41)-(4.2.42) and the boundary $a_*(s, y)$ provides the unique solution of the equation in (4.2.43) started from the value $a_*(y+, y) = g_*(y)$ given by the maximal solution of the equation in (4.2.20) started at $g_*(\infty)$ from (4.2.21) and staying strictly below the line $x = L$, whenever such a solution exists, for $(x, s, y) \in \hat{Q}_{2k-2}^3 \cup \tilde{Q}_{2l-2}^3$ defined in (4.2.45) and (4.2.46), respectively, and $V(x, s, y; \hat{s}_{2k-1}(y), \hat{s}_{2k}(y), \bar{y}(s))$ is given by (4.2.51), whenever $(x, s, y) \in \hat{Q}_{2k-1}^3$

defined in (4.2.47), with $C_i(s, y; \widehat{s}_{2k-1}(y), \widehat{s}_{2k}(y), \bar{y}(s))$, $i = 1, 2$, solving the system of equations in (4.2.7)-(4.2.8) and satisfying the conditions of (4.2.48)-(4.2.50), $k = 1, \dots, \widehat{k}$ and $l \in \mathbb{N}$, where (4.2.49) changes its form to $C_1(\infty, y) = 0$, for the case $k = \widehat{k}$.

Proposition 4.3.3 *In the perpetual American strangle option case $0 < L < K < \infty$ in the particular case $\delta(s, y) = \delta(s)$ and $\sigma(s, y) = \sigma(s)$, the value function $V_*(x, s, y) = U_*(x, s)$ of the optimal stopping problem (4.1.4) has the expression*

$$U_*(x, s) = \begin{cases} U(x, s; g_*(s), h_*(s)), & \text{if } 0 < g_*(s) < x < h_*(s) \leq s \\ U(x, s; g_*(s)), & \text{if } 0 < g_*(s) < x \leq s < h_*(s) \\ (L - x)^+ \vee (x - K)^+, & \text{if } 0 < x \leq g_*(s) \text{ or } h_*(s) \leq x \leq s \end{cases} \quad (4.3.3)$$

and the optimal stopping time is given by (4.1.6) for the boundary functions $a_*(s, y) = g_*(s)$ and $b_*(s, y) = h_*(s)$, which are specified together with the functions $U(x, s; g_*(s), h_*(s))$ and $U(x, s; g_*(s))$, as follows:

The function $U(x, s; g_*(s), h_*(s))$ is given by (4.2.24)-(4.2.25) and the boundaries $g_*(s)$ and $h_*(s)$ are uniquely determined by (4.2.26)-(4.2.27), for $(x, s) \in \widetilde{R}_{2l-1}^2$ defined in (4.2.14), and the function $U(x, s; g_*(s))$ is given by (4.2.18)-(4.2.19) and the boundary $g_*(s)$ provides the unique solution of the equation in (4.2.20) started at $g_*(\widetilde{s}_{2l-1})$ from (4.2.26), for $(x, s) \in \widetilde{R}_{2l}^2 \cup \widehat{Q}_{2k-1}^2$ defined in (4.2.15) and (4.2.22), respectively, $l = 1, \dots, \widetilde{l}$ and $k \in \mathbb{N}$.

Since all the parts of the assertion formulated above are proved using similar arguments, we only give a proof for the three-dimensional optimal stopping problem related to the perpetual American put option in part (ii) of Proposition 4.3.2, which represents the most complicated and informative case.

Proof of Proposition 4.3.2 (ii). In order to verify the assertion stated above, it remains to show that the function defined in (4.3.2) coincides with the value function in (4.1.4) and that the stopping time τ_* in (4.1.6) is optimal with $b_*(s, y) = \infty$ and the boundary $a_*(s, y)$ specified above. For this, let $a(s, y)$ be the unique solution of (4.2.43) starting from the value $a(y+, y) = g(y)$, being any solution of (4.2.20) starting from $a_*(\infty, \infty) = g_*(\infty)$ in (4.2.21) and satisfying $g(s) < L$ for all s . Let us also denote by $V_a(x, s, y)$ the right-hand side of the expression in (4.3.2) associated with this $a(s, y)$. It then follows using straightforward calculations and the assumptions presented above that the function $V_a(x, s, y)$ solves the system (4.1.11)-(4.1.13), while the normal-reflection and smooth-fit conditions are satisfied in (4.1.16) and (4.1.17). Hence, taking into account the fact that the function $V_a(x, s, y)$ is $C^{2,1,1}$ and the

boundary $a(s, y)$ is assumed to be continuously differentiable for all $0 < y < s$, by applying the change-of-variable formula from [92; Theorem 3.1] to $e^{-rt} V_a(X_t, S_t, Y_t)$, we obtain

$$\begin{aligned} e^{-rt} V_a(X_t, S_t, Y_t) &= V_a(x, s, y) + M_t \\ &+ \int_0^t e^{-ru} (\mathbb{L}V_a - rV_a)(X_u, S_u, Y_u) I(X_u \neq S_u - Y_u, X_u \neq a(S_u, Y_u), X_u \neq S_u) du \\ &+ \int_0^t e^{-ru} \partial_s V_a(X_u, S_u, Y_u) I(X_u = S_u) dS_u + \int_0^t e^{-ru} \partial_y V_a(X_u, S_u, Y_u) I(X_u = S_u - Y_u) dY_u \end{aligned} \quad (4.3.4)$$

where the process $M = (M_t)_{t \geq 0}$ given by

$$M_t = \int_0^t e^{-ru} \partial_x V_a(X_u, S_u, Y_u) I(X_u \neq S_u - Y_u, X_u \neq S_u) \sigma(S_u, Y_u) X_u dB_u \quad (4.3.5)$$

is a square integrable martingale under $P_{x,s,y}$. Note that, since the time spent by the process X at the boundary surface $\{(x, s, y) \in E^3 \mid x = a(s, y)\}$ as well as at the planes d_1^3 and d_2^3 , is of Lebesgue measure zero, the indicators in the second line of the formula (4.3.4) as well as in the formula (4.3.5) can be ignored. Moreover, since the process S increases only at the plane d_1^3 and the process Y increases only at the plane d_2^3 , the indicators in the third and fourth line of (4.3.4) can also be set equal to one.

By using straightforward calculations and the arguments from the previous section, it is verified that $(\mathbb{L}V_a - rV_a)(x, s, y) \leq 0$ for all $(x, s, y) \in E^3$ such that $x \neq a(s, y)$, $x \neq s - y$, and $x \neq s$. Moreover, it is shown by means of standard arguments that the property (4.1.14) also holds, which together with (4.1.12)-(4.1.13) implies that the equality $V_a(x, s, y) \geq (L - x)^+$ is satisfied for all $(x, s, y) \in E^3$. It therefore follows from the expression (4.3.4) that the inequalities

$$e^{-r\tau} (L - X_\tau)^+ \leq e^{-r\tau} V_a(X_\tau, S_\tau, Y_\tau) \leq V_a(x, s, y) + M_\tau \quad (4.3.6)$$

hold for any finite stopping time τ with respect to the natural filtration of X .

Taking the expectation with respect to $P_{x,s,y}$ in (4.3.6), by means of the optional sampling theorem (see, e.g. [69; Chapter I, Theorem 3.22]), we get

$$\begin{aligned} E_{x,s,y} [e^{-r(\tau \wedge t)} (L - X_{\tau \wedge t})^+] &\leq E_{x,s,y} [e^{-r(\tau \wedge t)} V_a(X_{\tau \wedge t}, S_{\tau \wedge t}, Y_{\tau \wedge t})] \\ &\leq V_a(x, s, y) + E_{x,s,y} M_{\tau \wedge t} = V_a(x, s, y) \end{aligned} \quad (4.3.7)$$

for all $(x, s, y) \in E^3$. Hence, letting t go to infinity and using Fatou's lemma, we obtain that for any finite stopping time τ the inequalities

$$E_{x,s,y} [e^{-r\tau} (L - X_\tau)^+] \leq E_{x,s,y} [e^{-r\tau} V_a(X_\tau, S_\tau, Y_\tau)] \leq V_a(x, s, y) \quad (4.3.8)$$

are satisfied for all $(x, s, y) \in E^3$. Taking first the supremum over all stopping times τ and then the infimum over all a , we conclude that

$$E_{x,s,y} [e^{-r\tau_*} (L - X_{\tau_*})^+] \leq \inf_a V_a(x, s, y) = V_{a_*}(x, s, y) \quad (4.3.9)$$

where $a_*(s, y)$ is the unique solution of (4.2.43) starting from the value $a_*(y+, y) = g_*(y)$, being the maximal solution to (4.2.20) starting from $a_*(\infty, \infty) = g_*(\infty)$ in (4.2.21) and staying strictly below the level L . Recalling that $V_a(x, s, y)$ is decreasing in the function $a < L$, we see that the infimum in (4.3.9) is attained over any sequence of solutions $(a_n(s, y))_{n \in \mathbb{N}}$ to (4.2.43) starting from the value $a_n(y+, y) = g_n(y)$, solving (4.2.20) such that $g_n(y) \uparrow g_*(y)$ and thus $a_n(s, y) \uparrow a_*(s, y)$ as $n \rightarrow \infty$. Since the inequalities in (4.3.8) holds also for $a_*(s, y)$, we see that (4.3.9) holds for $a_*(s, y)$ and $(x, s, y) \in E^3$, as well. Note that, $V_a(x, s, y)$ in (4.3.7) is superharmonic for the Markov process (X, S, Y) on E^3 . Recalling that $V_a(x, s, y)$ is decreasing in $a < L$ and that $V_a(x, s, y) \geq (L - x)^+$ for all $(x, s, y) \in E^3$, we observe that the selection of the maximal solution $a_*(s, y)$, which stays strictly below the plane $x = L$, whenever such a choice exists, is equivalent to invoking the superharmonic characterization of the value function (smaller superharmonic function dominating the payoff function, see also [97; Chapter 1] or [90]).

To prove that $a_*(s, y)$ is optimal on E^3 , we consider the sequence of stopping times τ_n defined as in (4.1.6) with $a_n(s, y)$ instead of $a_*(s, y)$, where $a_n(s, y)$ is the unique solution of (4.2.43) starting from the value $a_n(y+, y) = g_n(y)$, solving (4.2.20) starting from $a_*(\infty, \infty) = g_*(\infty)$ in (4.2.21), such that $g_n(s_n) = L$, for some $s_n \downarrow 0$ as $n \rightarrow \infty$. By virtue of the fact that the function $V_{a_n}(x, s, y)$ from the right-hand side of the expression in (4.3.2) associated with this $a_n(s, y)$, satisfies the system (4.1.11)-(4.1.14) with (4.1.17) and taking into account the structure of τ_n given by (4.1.6) with $a_n(s, y)$ instead of $a_*(s, y)$, it follows from the equivalent expression of (4.3.4) that the equalities

$$e^{-r(\tau_n \wedge t)} (L - X_{\tau_n \wedge t})^+ = e^{-r(\tau_n \wedge t)} V_{a_n}(X_{\tau_n \wedge t}, S_{\tau_n \wedge t}, Y_{\tau_n \wedge t}) = V_{a_n}(x, s, y) + M_{\tau_n \wedge t} \quad (4.3.10)$$

hold for all $(x, s, y) \in E^3$. Observe that, $\tau_n \uparrow \tau_*$ and the variable $e^{-r\tau_*} (L - X_{\tau_*})^+$ is bounded on the set $\{\tau_* = \infty\}$. Taking into account the fact that the boundary $a_*(s, y)$ is bounded, it is easily seen that the property $P_{x,s,y}(\tau_* < \infty) = 1$ holds, for all $(x, s, y) \in E^3$. Hence, letting t and n go to infinity and using the conditions of (4.1.12) and (4.1.17) as well as the fact that $\tau_n \uparrow \tau_*$, we can apply the Lebesgue dominated convergence theorem for (4.3.10) to obtain the equality

$$E_{x,s,y} [e^{-r\tau_*} (L - X_{\tau_*})^+] = V_{a_*}(x, s, y) \quad (4.3.11)$$

for all $(x, s, y) \in E^3$, which together with (4.3.9) directly implies the desired assertion. \square

Bibliography

- [1] ABRAMOVITZ, M. and STEGUN, I. A. (1972). *Handbook of Mathematical Functions with Formulas, Graphs, and Mathematical Tables*. National Bureau of Standards. Wiley, New York.
- [2] ALFONSI, A. and JOURDAIN, B. (2008). General duality for perpetual American options. *International Journal of Theoretical and Applied Finance* **11** (545–566).
- [3] ALFONSI, A. and JOURDAIN, B. (2009). A call-put duality for perpetual American options. *Nonlinear Differential Equations and Applications* **16** (523–554).
- [4] ALILI, L. and KYPRIANOU, A. E. (2005). Some remarks on first passage of Lévy processes, the American put and pasting principles. *Annals of Applied Probability* **15** (2062–2080).
- [5] ASMUSSEN, S., AVRAM, F. and PISTORIUS, M. (2003). Russian and American put options under exponential phase-type Lévy models. *Stochastic Processes and their Applications* **109** (79–111).
- [6] AVRAM, F., KYPRIANOU, A. E. and PISTORIUS, M. (2004). Exit problems for spectrally negative Lévy processes and applications to (Canadized) Russian options. *Annals of Applied Probability* **14**(1) (215–238).
- [7] BATEMAN, H. and ERDÉLYI, A. (1953). *Higher Transcendental Functions*. Mc Graw-Hill, New York.
- [8] BAURDOUX, E. J. and KYPRIANOU, A. E. (2004). Further calculations for Israeli options. *Stochastics* **76** (549–569).
- [9] BAURDOUX, E. J. and KYPRIANOU, A. E. (2008). The McKean stochastic game driven by a spectrally negative Lévy process. *Electronic Journal of Probability* **13**(8) (173–197).
- [10] BAURDOUX, E. J. and KYPRIANOU, A. E. (2009). The Shepp-Shiryaev stochastic game driven by a spectrally negative Lévy process. *Theory of Probability and its Applications* **53** (481–499).

- [11] BAURDOUX, E. J., KYPRIANOU, A. E. and PARDO, J. C. (2011). The Gapeev-Kühn stochastic game driven by a spectrally positive Lévy process. *Stochastic Processes and their Applications* **121**(6) (1266–1289).
- [12] BAYRAKTAR, E. and SÎRBU, M. (2012). Stochastic Perron’s method and verification without smoothness using viscosity comparison: Obstacle problems and Dynkin games. To appear in *Proceedings of American Mathematical Society* (13 pp).
- [13] BEIBEL, M. and LERCHE, H. R. (2000). Optimal stopping of regular diffusions under random discounting. *Theory of Probability and its Applications* **45**(4) (547-557).
- [14] BENSOUSSAN, A. and FRIEDMAN, A. (1974). Non-linear variational inequalities and differential games with stopping times. *Journal of Functional Analysis* **16** (305–352).
- [15] BENSOUSSAN, A. and FRIEDMAN, A. (1977). Nonzero-sum stochastic differential games with stopping times and free-boundary problems. *Transactions of American Mathematical Society* **231** (275–327).
- [16] BENSOUSSAN, A. and LIONS, J. L. (1982). *Applications of Variational Inequalities in Stochastic Control*. (French Edition 1978) North Holland, Amsterdam.
- [17] BISMUT, J. M. (1977). Sur un problème de Dynkin. *Zeitschrift für Wahrscheinlichkeitstheorie und verwandte Gebiete* **39** (31-53).
- [18] CARMONA, R. and DAYANIK, S. (2008). Optimal multiple-stopping of linear diffusions. *Mathematics of Operations Research* **33**(2) (446–460).
- [19] CARMONA, R. and TOUZI, N. (2008). Optimal multiple stopping and valuation of swing options. *Mathematical Finance* **18**(2) (239–268).
- [20] CHIARELLA, C. and KANG, B. (2009). The evaluation of American compound option prices under stochastic volatility using the sparse grid approach. *Research Centre Research Paper No. 245, February, 2009*, University of Technology, Sydney, Quantitative Finance.
- [21] CHRISTENSEN, S. and IRLE, A. (2011). A harmonic function technique for the optimal stopping of diffusions. *Stochastics An International Journal of Probability and Stochastic Processes* **83** (4-6) (347-363).
- [22] CVITANIĆ, J. and KARATZAS, I. (1996). Backward stochastic differential equations with reflection and Dynkin games. *Annals of Probability* **24** (2024–2056).
- [23] DALANG, R. C. and HONGLER, M.-O. (2004). The right time to sell a stock whose price is driven by Markovian noise. *Annals of Applied Probability* **14** (2167–2201).

- [24] DAYANIK, S. and KARATZAS, I. (2003). On the optimal stopping problem for one-dimensional diffusions. *Stochastic Processes and their Applications* **107**(2) (173-212).
- [25] DERMAN, E. and KANI, I. (1994). Riding on a smile. *Risk* **7** (32-39).
- [26] DETEMPLE, J. (2006). *American-Style Derivatives: Valuation and Computation*. Chapman and Hall/CRC, Boca Raton.
- [27] DIXIT, A. K. and PINDYCK, R. S. (1994). *Investment under Uncertainty*. Princeton University Press, New Jersey.
- [28] DUBINS, L., SHEPP, L. A. and SHIRYAEV, A. N. (1993). Optimal stopping rules and maximal inequalities for Bessel processes. *Theory of Probability and its Applications* **38**(2) (226-261).
- [29] DUCKWORTH, J. K. and ZERVOS, M. (2000). An investment model with entry and exit decisions. *Journal of Applied Probability* **37** (547-559).
- [30] DUPIRE, B. (1994). Pricing with a smile. *Risk* **7** (18-20).
- [31] DYNKIN, E. B. (1963). The optimum choice of the instant for stopping a Markov process. *Soviet Mathematical Doklady* **4** (627-629).
- [32] DYNKIN, E. B. (1969). Game variant of a problem on optimal stopping. *Soviet Mathematical Doklady* **10** (270-274).
- [33] EGAMI, M. and XU, M. (2008). A continuous-time search model with job switch and jumps. *Mathematical Methods of Operations Research* **70**(2) (241-267).
- [34] EKSTRÖM, E. (2003). Perpetual American put options in a level-dependent volatility model. *Journal of Applied Probability* **40** (783-789).
- [35] EKSTRÖM, E. (2004). Properties of American option prices. *Stochastic Processes and their Applications* **114** (265-278).
- [36] EKSTRÖM, E. and HOBSON, D. (2011). Recovering a time-homogeneous stock price process from perpetual option prices. *Annals of Applied Probability* **21**(3) (1102-1135).
- [37] EKSTRÖM, E. and PESKIR, G. (2008) Optimal stopping games for Markov processes. *SIAM Journal on Control and Optimization* **47**(2) (684-702).
- [38] EKSTRÖM, E. and VILLENEUVE, S. (2006) On the value of optimal stopping games. *Annals of Applied Probability* **16**(3) (1576-1596).

- [39] ELLIOTT, R. J., AGGOUN, L. and MOORE, J. B. (1995). *Hidden Markov Models: Estimation and Control*. Springer, New York.
- [40] FRIEDMAN, A. (1973). Stochastic games and variational inequalities. *Archive for Rational Mechanics and Analysis* **51** (321–346).
- [41] FRIEDMAN, A. (1976). *Stochastic Differential Equations and Applications II*. Academic Press, New York.
- [42] GAPEEV, P. V. (2005). The spread option optimal stopping game. *Exotic Option Pricing and Advanced Lévy Models*. Kyprianou, A., Schoutens, W. and Wilmott, P. (eds.) Wiley, Chichester (293–305).
- [43] GAPEEV, P. V. (2007). Discounted optimal stopping for maxima of some jump-diffusion processes. *Journal of Applied Probability* **44** (713–731).
- [44] GAPEEV, P. V. (2007). *Optimal stopping problems for mathematical statistics and finance*. Habilitation thesis, Humboldt University of Berlin.
- [45] GAPEEV, P. V. (2012). Pricing of perpetual American options in a model with partial information. *International Journal of Theoretical and Applied Finance* **15**(1) (1250010, 21 pp).
- [46] GAPEEV, P. V. and KÜHN, C. (2005). Perpetual convertible bonds in jump-diffusion models. *Statistics and Decisions* **23**(1) (15–31).
- [47] GAPEEV, P. V. and LERCHE, H. R. (2011). On the structure of discounted optimal stopping problems for one-dimensional diffusions. *Stochastics: An International Journal of Probability and Stochastic Processes* **83**(4–6) (537–554).
- [48] GAPEEV, P. V. and RODOSTHENOUS, N. (2012). On the pricing of perpetual American compound options. *The Musiela Festschrift*. Kabanov Yu. M., Rutkowski M. and Zariphopoulou Th. (eds.) Springer (335–361).
- [49] GAPEEV, P. V. and RODOSTHENOUS, N. (2013). Perpetual American options in a diffusion model with piecewise-linear coefficients. *Statistics and Risk Modeling* **30**(1) (1–21).
- [50] GAPEEV, P. V. and SHIRYAEV, A. N. (2011). On the sequential testing problem for some diffusion processes. *Stochastics: An International Journal of Probability and Stochastic Processes* **83**(4–6) (519–535).

- [51] GAPEEV, P. V. and SHIRYAEV, A. N. (2013). Bayesian quickest detection problems for some diffusion processes. *Advances in Applied Probability* **45**(1) (164–185).
- [52] GESKE, R. (1977). The valuation of corporate liabilities as compound options. *Journal of Financial and Quantitative Analysis* **12** (541–552).
- [53] GESKE, R. (1978). The pricing of options with stochastic dividend yield. *Journal of Finance* **33**(2) (617–625).
- [54] GESKE, R. (1979). The valuation of compound options. *Journal of Financial Economics* **7** (63–81).
- [55] GLOVER, K., HULLEY, H. and PESKIR, G. (2013). Three-dimensional Brownian motion and the golden ratio rule. *Annals of Applied Probability* **23** (895–922).
- [56] GRAVERSEN, S. E. and PESKIR, G. (1998). Optimal stopping and maximal inequalities for geometric Brownian motion. *Journal of Applied Probability* **35**(4) (856–872).
- [57] GRAVERSEN, S. E. and PESKIR, G. (1998). Optimal stopping and maximal inequalities for linear diffusions. *Journal of Theoretical Probability* **11** (259–277).
- [58] GRIGELIONIS, B. I. and SHIRYAEV, A. N. (1966). On Stefan’s problem and optimal stopping rules for Markov processes. *Theory of Probability and its Applications* **11** (541–558).
- [59] GUO, X. (2001). An explicit solution to an optimal stopping problem with regime switching. *Journal of Applied Probability* **38** (464–481).
- [60] GUO, X. and SHEPP, L. A. (2001). Some optimal stopping problems with nontrivial boundaries for pricing exotic options. *Journal of Applied Probability* **38**(3) (647–658).
- [61] GUO, X. and ZERVOS, M. (2010). π options. *Stochastic Processes and their Applications* **120**(7) (1033–1059).
- [62] GUO, X. and ZHANG, Q. (2004). Closed-form solutions for perpetual American put options with regime switching. *SIAM Journal on Applied Mathematics* **64** (2034–2049).
- [63] HODGES, S. D. and SELBY, M. J. P. (1987). On the evaluation of compound options. *Management Science* **33** (347–355).
- [64] JACKA, S. D. (1991). Optimal stopping and best constants for Doob-like inequalities I: The case $p = 1$. *Annals of Probability* **19** (1798–1821).

- [65] JIANG, Z. and PISTORIUS, M. R. (2008). On perpetual American put valuation and first-passage in a regime-switching model with jumps. *Finance and Stochastics* **12** (331–355).
- [66] JOBERT, A. and ROGERS, L. C. G. (2006). Option pricing with Markov-modulated dynamics. *SIAM Journal on Control and Optimization* **44** (2063–2078).
- [67] KALLSEN, J. and KÜHN, C. (2004). Pricing derivatives of American and game type in incomplete markets. *Finance and Stochastics* **8**(2) (261–284).
- [68] KALLSEN, J. and KÜHN, C. (2005). Convertible bonds: financial derivatives of game type. *Exotic Option Pricing under Advanced Lévy Models*. Kyprianou, A. E., Schoutens, W., and Wilmott, P. eds. Wiley, Chichester (277–291).
- [69] KARATZAS, I. and SHREVE, S. E. (1991). *Brownian Motion and Stochastic Calculus*. (Second Edition) Springer, New York.
- [70] KARATZAS, I. and SHREVE, S. E. (1998). *Methods of Mathematical Finance*. Springer, New York.
- [71] KARATZAS, I. and WANG, H. (2001). Connections between bounded-variation control and Dynkin games. *Optimal Control and Partial Differential Equations* (Volume in Honour of Alain Bensoussan) Menaldi, J. L. et al. eds. IOS Press, Amsterdam (363–373).
- [72] KOLMOGOROV, A. N. (1992). On analytic methods in probability theory. *Selected works of A. N. Kolmogorov. Volume II. Probability Theory and Mathematical Statistics*. Shiryaev, A. N. ed. Kluwer, Dordrecht.
- [73] KIFER, Y. (2000). Game options. *Finance and Stochastics* **4** (443–463).
- [74] KRYLOV, N. V. (1971). Control of Markov processes and W -spaces. *Izvestija* **5** (233–266).
- [75] KRYLOV, N. V. (1980). *Controlled Diffusion Processes*. Springer, New York.
- [76] KÜHN, C. and KYPRIANOU, A. E. (2007). Callable puts as composite exotic options. *Mathematical Finance* **17**(4) (487–502).
- [77] KYPRIANOU, A. E. (2004). Some calculations for Israeli options. *Finance and Stochastics* **8**(1) (73–86).
- [78] LEPELTIER, J. P. and MAINGUENAU, M. A. (1984). Le jeu de Dynkin en théorie générale sans l’hypothèse de Mokobodski. *Stochastics* **13** (25–44).

- [79] LIPTSER, R. S. and SHIRYAEV, A. N. (2001). *Statistics of Random Processes I*. (Second Edition, First Edition 1977) Springer, Berlin.
- [80] LU, B. (2010). Recovering a piecewise constant volatility from perpetual put option prices. *Journal of Applied Probability* **47** (680–692).
- [81] MCKEAN, H. P. (1965). Appendix: A free boundary problem for the heat equation arising from a problem of mathematical economics. *Industrial Management Review* **6** (32–39).
- [82] MIJATOVIC, A. and PISTORIUS, M. R. (2012). On the drawdown of completely asymmetric Lévy processes *Stochastic Processes and their Applications* **22** (3812–3836).
- [83] MORDECKI, E. (1999). Optimal stopping for a diffusion with jumps. *Finance and Stochastics* **3** (227–236).
- [84] MORDECKI, E. (2002). Optimal stopping and perpetual options for Lévy processes. *Finance and Stochastics* **6**(4) (473–493).
- [85] NEVEU, J. (1975). *Discrete-Parameter Martingales*. North-Holland, Amsterdam.
- [86] ØKSENDAL, B. (1998). *Stochastic Differential Equations. An Introduction with Applications*. (Fifth Edition) Springer, Berlin.
- [87] OTT, C. (2012). Optimal stopping problems for the maximum process with upper and lower caps. *Preprint*.
- [88] OTT, C. (2013). *Optimal Stopping Problems for the Maximum Process*. PhD thesis, University of Bath.
- [89] PEDERSEN, J. L. (2000). Discounted optimal stopping problems for the maximum process. *Journal of Applied Probability* **37**(4) (972–983).
- [90] PESKIR, G. (1998). Optimal stopping of the maximum process: The maximality principle. *Annals of Probability* **26**(4) (1614–1640).
- [91] PESKIR, G. (2005). A change-of-variable formula with local time on curves. *Journal of Theoretical Probability* **18** (499–535).
- [92] PESKIR, G. (2007). A change-of-variable formula with local time on surfaces. *Séminaire de Probabilité XL*. Lecture Notes in Mathematics **1899**, Springer (69–96).
- [93] PESKIR, G. (2008). Optimal stopping games and Nash equilibrium. *Theory of Probability and its Applications* **53** (558–571).

- [94] PESKIR, G. (2010). Quickest detection of a hidden target and extremal surfaces. *Research Report No. 23, Probab. Statist. Group Manchester* (25 pp).
- [95] PESKIR, G. (2012). A duality principle for the Legendre transform. *Journal of Convex Analysis* **19** (609–630).
- [96] PESKIR, G. (2012). Optimal detection of a hidden target: The median rule. *Stochastic Processes and their Applications* **122** (2249–2263).
- [97] PESKIR, G. and SHIRYAEV, A. N. (2006). *Optimal Stopping and Free-Boundary Problems*. Birkhäuser, Basel.
- [98] POSPISIL L., VECER, J. and HADJILIADIS, O. (2009) Formulas for stopped diffusion processes with stopping times based on drawdowns and drawups. *Stochastic Processes and Applications* **119**(8) (2563–2578).
- [99] RADNER, R. and SHEPP, L. A. (1996). Risk vs. profit potential: A model for corporate strategy. *Journal of Economic Dynamics and Control* **20** (1373–1393).
- [100] RÜSCHENDORF, L. and URUSOV, M. A. (2008). On a class of optimal stopping problems for diffusions with discontinuous coefficients. *Annals of Applied Probability* **18**(3) (847–878).
- [101] SALMINEN, P. (1985) Optimal stopping of one-dimensional diffusions. *Mathematische Nachrichten* **124**(1) (85–101).
- [102] SHEPP, L. A. and SHIRYAEV, A. N. (1993). The Russian option: reduced regret. *Annals of Applied Probability* **3**(3) (631–640).
- [103] SHEPP, L. A. and SHIRYAEV, A. N. (1994). A new look at the pricing of Russian options. *Theory of Probability and its Applications* **39**(1) (103–119).
- [104] SHIRYAEV, A. N. (1978). *Optimal Stopping Rules*. Springer, Berlin.
- [105] SHIRYAEV, A. N. (1999). *Essentials of Stochastic Finance*. World Scientific, Singapore.
- [106] SÎRBU, M., PIKOVSKY, I. and SHREVE, S. E. (2004). Perpetual convertible bonds. *SIAM Journal on Control and Optimization* **43** (58–85).
- [107] SNELL, J. L. (1952). Applications of martingale systems theorems. *Transactions of American Mathematical Society* **73** (293–312).
- [108] STETTNER, L. (1982). On a general zero-sum stochastic game with optimal stopping. *Probability and Mathematical Statistics* **3**(1) (103–112).

- [109] VILLENEUVE, S. (2007). On threshold strategies and the smooth-fit principle for optimal stopping problems. *Journal of Applied Probability* **44**(1) (181–198).
- [110] ZVONKIN, A. K. (1974). A transformation of the phase space of a diffusion process that removes the drift. *Mathematics of the USSR - Sbornik* **22**(1) (129–149).