

Provided by the author(s) and University College Dublin Library in accordance with publisher policies. Please cite the published version when available.

Title	A comparative study between the NGI direct simple shear apparatus and the Mikasa direct shear apparatus
Author(s)	Hanzawa, Hideo; Nutt, Nigel; Lunne, Tom; Tang, Y.X.; Long, Michael (Michael M.)
Publication Date	2007-02
Publication information	Soils and Foundations, 47 (1): 47-58
Publisher	Japanese Geotechnical Society
Link to publisher's version	http://dx.doi.org/10.3208/sandf.47.47
This item's record/more information	http://hdl.handle.net/10197/3254
DOI	http://dx.doi.org/10.3208/sandf.47.47

Downloaded 2013-09-16T11:52:01Z

Some rights reserved. For more information, please see the item record link above.



Journal: Soils and Foundations (The Japanese Geotechnical Society)

Title of paper: A comparative study between the NGI direct simple shear apparatus and the Mikasa direct shear apparatus

Names of authors: Hideo Hanzawaⁱ⁾, Nigel Nuttⁱⁱ⁾, Tom Lunneⁱⁱⁱ⁾, Y.X. Tang^{iv)} and Michael Long^{v)}

Affiliation of authors:

- i) Deceased, formerly Technical Research Unit, Toa Corporation, Japan
- ii) Apis Consulting Group, Canberra, Australia (formerly Norwegian Geotechnical Institute, NGI, Oslo)
- iii) Norwegian Geotechnical Institute (NGI), Oslo, Norway
- iv) Kanmon Kowan Construction Co., Ltd., Japan (formerly Toa Corporation)
- v) University College Dublin (UCD), Ireland

Contact address of corresponding author: Michael Long, Department of Civil Engineering, University College Dublin, Earlsfort Terrace, Dublin 2, Ireland.

Phone: +353-1-7167333

Fax: +353-1-7167399

e-mail: Mike.Long@ucd.ie

Date paper originally written: June 2005

Date paper revised: February 2006

ABSTRACT

A comparative study of the NGI Direct Simple Shear Test (DSST) and the Mikasa Direct Shear Test (DST) is reported. Samples from Norwegian Drammen clay and Japanese Ariake clay were subjected to both types of test. An evaluation of these test results and a theoretical consideration on the different shearing mechanisms has shown that although the DST give generally higher stiffness and strength than the DSST, these differences can mainly be accounted for by the different shearing mechanisms and shearing rates. Sample disturbance due to transportation and handling may also be the reason for some of the difference. Tests on undisturbed and remoulded Drammen clay consolidated to stresses much higher than the in situ effective overburden stress give almost identical results. Thus the effects of sample disturbance and in situ structure in the clay were eradicated.

Key words: soft clays; laboratory tests; direct shear test, direct simple shear test.

INTRODUCTION

Laboratory shear testing has become an integral part of many soil investigations for the determination of the strength parameters of a soil. In Norway preference is given to the use of the Direct Simple Shear apparatus, which was developed by Bjerrum and Landva (1966). For example the mode of failure in the DSST is similar to that encountered theoretically under the base of offshore gravity structures or in translational type slope stability problems. In Japan, the Improved Direct Shear apparatus, developed by Mikasa in 1960 and described by Takada (1993), has gained increasing popularity. The extensive application of the DSST and DST to both onshore and offshore investigations warrants a study into the differences between

these two tests. Such a study is presented in this paper based on a programme of tests on two normally consolidated marine clays: Ariake clay from Japan and Drammen clay from Norway. Tsuji et al. (1998) have previously reported on tests carried out in Japan on both clays.

This previous work is now extended through a series of comparative tests in both apparatuses for the two clays, with work carried out both in Norway and in Japan. The study is aimed at identifying any differences in the measured test results and determining the causes for these differences. Consideration is given to theoretical differences in the shearing mechanism; techniques for extrusion, preparation and mounting of the sample; the reconsolidation process; sample dimensions; rate of shearing; the influence of remoulding; and testing of overconsolidated soil.

VALIDITY OF SHEAR TESTING

Direct Simple Shear Test (DSST)

In the direct simple shear test conditions of simple shear strain are imposed to the specimen, as shown in Fig. 1(a). The vertical normal and horizontal shear forces during shear are measured and the shear strain, γ_{xy} , is given by u/h_0 for a shear displacement, u , and an initial consolidated specimen height, h_0 . For simplicity undrained tests are simulated by holding the volume of the specimen constant. In constant volume shear testing, it is assumed that the change in applied vertical stress as the specimen height (and hence volume) is maintained constant during shear is equal to the excess pore pressure that would have been measured in a truly undrained test with constant total vertical stress. This procedure was used with the introduction of the DSST (Bjerrum and Landva, 1966), and was confirmed in a comprehensive study on normally consolidated Drammen clay reported by Dyvik et al. (1987).

During shear distortion, the soil experiences a non-uniform shear stress distribution on the top and bottom faces. For practical purposes, this state of stress is normally considered close enough to the state of pure shear to justify the interpretation of the test as under pure shear stress conditions. To justify this assumption, Lucks et al. (1972) performed theoretical linear elastic analyses of the NGI type DSST, showing that 70% of the sample was uniformly stressed. However Saada and Townsend (1981) criticised some of the assumptions used in such analyses, particularly concerning the amount of fixity at the boundaries, and cite the results of Wright et al. (1978) who used photo-elastic methods to illustrate a non-uniform specimen stress distribution. Nevertheless, results from tests conducted by Vucetic and Lacasse (1982) in the NGI apparatus on medium stiff clay at different height to diameter ratios have shown that the non-uniformities do not significantly affect the measured soil behaviour. Airey and Wood (1987) performed direct simple shear tests on normally consolidated specimens of kaolin using a specially instrumented apparatus. In this way the stress strain behaviour of the central core of a specimen could be determined representing that portion which most closely experiences a state of pure stress (or ideal simple shear). The results were then compared with similar tests using a standard NGI type DSST where only the average stress-strain response throughout the whole specimen can be measured. Airey and Wood (1987) showed that the values of shear strength and shear modulus determined from the average stresses underpredict ideal simple shear values by about 10%.

Direct Shear Test (DST)

In the direct shear test, two halves of a block of soil, rigidly confined, are forced to translate relative to each other in the horizontal direction, as shown in Fig. 1(b). The vertical normal and horizontal shear forces applied to the specimen are measured,

and converted to average values of direct total stress, σ_y , and shear stress, τ_{xy} . These values are then assumed to apply to the forced plane of shear in the specimen and to be representative of the stresses experienced in the localised region where failure occurs. In a similar procedure to the DSST undrained tests are simulated by holding the volume of the specimen constant and recording the change in vertical stress.

The relative displacement, u , of the two halves of the specimen is recorded. Often this value is converted to a shear strain, $\gamma_{xy} = u/h$, where h is the height of the element of the specimen which is assumed to be undergoing the shear deformation, as pointed out by Wroth (1987). This value is conveniently taken as h_0 , the initial consolidated height of the specimen, although such an assumption must be given consideration when interpreting stiffness parameters from direct shear data.

The primary criticisms applied to the direct shear test relate to the non-uniformity of stress and strain throughout the sample (Saada and Townsend, 1981). This occurs as a result of the rigid platens which are used to confine the specimen. Stress concentrations occur at the front and rear edges of the lower and upper blocks respectively, giving rise to progressive failure along the plane of shearing, so that the full shearing strength of the specimen is not mobilised simultaneously. Takada (1993), however, uses photographic evidence from tests on alluvial clay to show that up to the point of failure, specimen deformations are remarkably uniform, and only at greater strains do non-uniformities become increasingly evident. Potts et al. (1987) used finite element analyses to determine the stress state within the rectangular shear box test, and compare the stress-strain behaviour with that of ideal simple shear, shown in Fig 1(a). An elastic-plastic soil model was used and the influences of volume change, initial stress and strain softening were examined. These analyses indicated the propagation of highly stressed zones from the edges of the box, which

grows and rotates during shear. This type of behaviour confirmed the experimental results of Morgenstern and Tchalenko (1967) who used optical examination of samples of kaolin in the direct shear box. However, despite such anomalous behaviour, Potts et al. (1987) concluded that for the no volume change condition, the ultimate strength in ideal simple shear is only overestimated by direct shear by about 6%. Similarly, load displacement behaviour was shown to be consistently stiffer than for ideal simple shear.

THEORETICAL MECHANISMS OF SHEAR

As shown above, evidence suggests that for tests in clay, the DSST underpredicts both the strength and stiffness of ideal simple shear, while the DST overpredicts both the strength and stiffness of ideal simple shear. Differences between the DSST and DST can be attributed to different failure mechanisms. In the DST, failure of the specimen is forced along the horizontal plane. In the DSST, two possible mechanisms can occur; one of translation along a series of horizontal planes, shown in Fig. 2(a), or one of translation along vertical planes with an associated rotation of those planes, as shown in Fig. 2(b). In the DSST either mechanism is possible, but an element of soil will choose that mechanism which requires the least resistance, i.e. the second one. This argument was first presented by de Josselin de Jong (1972), and taken up by Wroth (1984), who went on to suggest that at the ultimate stage of a test, after failure, the element resorts back to the first mechanism. Wroth cited experimental results from Ladd and Edgers (1972) and Borin (1973) to confirm this behaviour. The implication is that while the DSST should give lower peak strength than the DST, the ultimate strengths should be similar.

It is, however, difficult to quantify such differences in strength, because the standard DSST and DST apparatuses (reported in this study) do not allow

measurement of all the normal stresses. Hence it is not possible to determine the largest Mohr's circle of stress and corresponding shear strength. Using elasto-plastic constitutive equations, Ohta et al. (1985) developed theoretical expressions for the normalised undrained strength (τ_f/σ'_{v0}) of K_0 consolidated clays under plane strain conditions, for the two test types, as follows:

$$\text{DSST} \quad \frac{\tau_f}{\sigma'_{v0}} = \frac{(1+2K_0)Me^{-\Lambda}}{3\sqrt{3} \cosh \beta} \quad (1)$$

$$\text{DST} \quad \frac{\tau_f}{\sigma'_{v0}} = \frac{(1+2K_0)Me^{-\Lambda}}{3\sqrt{3}} \quad (2)$$

where:

$$\beta = \frac{\sqrt{3}\eta_0\Lambda}{2M} \quad (3)$$

$$\eta_0 = \frac{3(1-K_0)}{1+2K_0} \quad (4)$$

$$\Lambda = 1 - \frac{C_s}{C_c} \quad (5)$$

$$M = \frac{6 \sin \phi'}{3 - \sin \phi'} \quad (6)$$

σ'_{v0} is the in situ vertical effective stress, K_0 is the in situ stress ratio, ϕ' is the drained friction angle and C_s and C_c are the swelling and compression indices respectively.

Ohta et al. (1985) support their theory by citing data from Ladd (1973) and Bjerrum (1973) for clays of varying plasticity, including the plastic Drammen clay, used in this study. It is interesting to note that the expression for the DSST differs from that for the DST by the term $\cosh\beta$ in the denominator. Hence $\cosh\beta$ can be considered as a theoretical correction factor between shear strengths determined from

DST and DSST. Wroth (1984) shows that, for most clays, Λ can be well estimated as 0.8. The variation of $\cosh\beta$ with ϕ' for a range of K_0 values is presented in Fig. 3.

TESTING PROGRAMME

Description of Ariake Clay

The site of Ariake is located in Hizen-Kashima, Saga Prefecture in Kyushu Island, Japan. Extensive use has been made of the deposit for research purposes. For example a detailed description of its mechanical and chemical properties is presented by Hanzawa et al. (1990), Ohtsubo et al., 1995 and Tanaka et al. (1996). Some index properties of the material used in this study are shown on Fig. 4 (Tang et al., 1994). It is possible to divide the deposit into two strata; the upper clay, from 0 to 12 m depth, and the lower clay from 12 to 18 m depth. In the upper clay natural water content falls from more than 150% near the surface to about 120%. There is a corresponding increase in unit weight from about 12.5 kN/m³ to 13 kN/m³. In the lower clay the water content and unit weight are close to 100% and 14 kN/m³ respectively. For both strata the natural water content is greater than the liquid limit. Strain controlled oedometer tests, reported by Tang et al. (1994), reveal an overconsolidation ratio (OCR) of about 3.5 close to the surface, decreasing with depth to a value of about 1.5, see Figure 4. The water table is at about 0.8m depth.

Description of Drammen Clay

The site where Drammen clay samples were obtained is located about 45km south west of Oslo in the city of Drammen. The site has been used by the Norwegian Geotechnical Institute (NGI) for several earlier research programmes on site investigations including sampling, piezocone, lateral stresscone, self-boring pressuremeter, dilatometer, seismic cone, cross-hole seismic and field vane testing, see for example Lunne et al. (1976). An overview of the work and a description of the

characteristics of the clay are given by Lunne and Lacasse (1999). Several test sites were used by NGI over the years but the samples obtained for this study were from close to the city centre at the Museum Park / Danvikgata site. The soil profile and some characteristics of this site are shown on Fig. 5. In the top 5 m, sand and silty sand are encountered. Below this, the marine deposit consists of 5 m – 7 m of soft, plastic clay overlying 35 m of soft to medium stiff, lean clay. The plastic clay has a natural water content between 50% and 55%, and the plasticity index averages 28%. The underlying lean clay has water content of about 30% and plasticity index of 10% to 15%. The unit weight of the soil is on average 16.7 kN/m³ and 19 kN/m³ for the plastic and lean clays respectively. Field vane test results show significant scatter but typically increase from about 22 kPa in the plastic clay to 30 kPa in the lean clay at 25 m. The field vane sensitivity averages 7 in the upper clay and 3 below 10 m. Cone resistance values are low and typically increase from about 500 kPa in the plastic clay to 900 kPa at 25 m.

Preconsolidation stresses (p'_c) from incremental loading oedometer tests, reported by Lunne and Lacasse (1999) and shown on Figure 5, indicate an overconsolidation ratio of 1.5 in the plastic clay decreasing to 1.2 in the lean clay. Measurements from in situ total stress cells and hydraulic fracture tests as well as special laboratory tests suggest K_0 values of about 0.5.

Equipment for Direct Simple Shear Testing (DSST)

These tests were performed at NGI using the simple shear apparatus which is described in detail by Bjerrum and Landva (1966). The specimens were 67 mm in diameter (area of 35.3 cm²) and 16 mm in height, which is a height to diameter ratio of 0.24. The specimen area is kept constant by means of a reinforced rubber membrane, which provides constraint in the radial direction. This membrane allows

the specimen to be deformed vertically and in simple shear. At the top and bottom of the specimen are filter plates. The filters and the drainage tubes were saturated with water of the same salinity as the pore water in the clay. At the beginning of the test the specimen is subjected to K_0 consolidation stress in steps. Tests can be performed drained or undrained (as has been explained earlier).

Equipment for Direct Shear Testing (DST)

For this study DST tests were carried out at the TOA Corporation in Japan, using Mikasa's Improved Direct Shear apparatus. The apparatus is described in detail by Takada (1993). The cylindrical specimens were 60mm in diameter and 20mm in height, which is a height to diameter ratio of 0.33. The upper shear box is fixed to a loading plate which is horizontally guided by a set of rigid rollers. The lower shear box surrounds a loading plate of slightly smaller diameter, fixed to a vertically guided rigid loading rod, through which the vertical normal load is applied. Porous stones of rough silicon carbide are used to transmit the shear force effectively from the loading plates to the specimen surface. Loading is applied by translating the upper box over the fixed lower box at a constant rate. The apparatus was designed in such a way that friction between the upper and lower shear boxes, between the inside of the shear box and the loading plate and tilting of the loading plate could be minimised.

Soil Sampling

Undisturbed sampling of Ariake clay was performed to a depth of 15 m using a stationary piston sampler. The sample tubes were made of brass, with a wall thickness of 1.5 mm, an inside diameter of 75 mm and length of 1 m. On extraction, the undisturbed samples were carefully sealed with plastic film and placed in metal boxes. Paraffin wax was used to seal and support the samples in the boxes. The samples for testing in Norway were sent by air freight. Undisturbed sampling of

Drammen clay was also performed using a piston sampler. The sample tubes were made of steel, with a wall thickness of 2.6 mm, an inside diameter of 96 mm and length of 1 m. On extraction, the tubes were sealed with paraffin wax. Those samples for testing in Japan were sent by air freight.

Sample Preparation

The procedures used by TOA Corp. for the DST differ somewhat in preparation and mounting of the samples from those used by NGI for the DSST. In the TOA Corp. method, the extruded sample is trimmed by a wire saw to a diameter 1 mm greater than the specified diameter for the direct shear test. A metal ring, 20 mm long, of exact test diameter, and with a cutting edge is pushed down gently into the clay. The top and bottom ends of the specimen are trimmed, and the ring is placed on top of the upper shear box. A circular disc is then pushed by hand through the ring, thus pressing the specimen into the shear box.

In the NGI method, the extruded sample is pressed into a cutting cylinder, mounted on vertical guides. During this operation, the excess clay is cut away by a wire saw or spatula. Top and bottom filter stones are mounted, and the specimen is pressed gently into a suction cylinder holding the reinforced rubber membrane. The specimen, supported by top and bottom caps and the reinforced membrane sealed by o-rings, is then transferred to the direct simple shear apparatus.

Test Procedures

Tests were performed with both the DSST and the DST on specimens of upper and lower Ariake clay, and plastic and lean Drammen clay. For the Ariake clay NGI carried out 7 DSST tests and TOA carried out 14 DST tests. The division between upper and lower clay occurs at 12.1 m. Prior to testing, all specimens were K_0 consolidated up to σ'_{v0} , the estimated in situ vertical stress. This value was estimated

based on the values of soil unit weight measured for each test. Consolidation of the NGI specimens was carried out with 4 load steps; each load step being applied for a minimum of 30 minutes. The fully loaded specimen was then left overnight before shearing. A rate of shear of about 0.1% shear strain per minute was applied to the specimens. In comparison, consolidation of the TOA specimens was carried out with one load step over 10 minutes. Shearing was then immediately performed at a rate of 0.25mm/minute (corresponding to about 1.25% shear strain per minute).

The Drammen plastic and lean clays are separated by a thin layer of sand/gravel at a depth of about 10 to 11m. TOA carried out three series of DST tests on this clay. In the first series, a consolidation procedure was used that was the same as that used for the tests on Ariake clay, i.e. undisturbed specimens were reconsolidated to their estimated in situ overburden stress, in one load step, for 10 minutes immediately followed by a shearing load. The rate of shear under constant volume conditions was 0.25mm/minute (about 1.25% shear strain per minute). Fifteen tests were carried out in this way on samples from depths ranging from 6m to 19m.

In the second series of TOA tests, the trimmings from the samples taken from depths from 6m to 9m (i.e. plastic Drammen clay) were remoulded and then consolidated to a vertical effective stress of 392 kPa over one day, using the NGI procedure. On the following day the specimens were unloaded corresponding to a predetermined OCR. The rate of shearing under constant volume conditions of 0.1mm/minute (about 0.5% shear strain per minute) was used. Seven tests were carried out in this way, at laboratory OCR values between 1 and 40.

In the third TOA series of DST tests, undisturbed samples of plastic Drammen clay were used, from depths of 6 m, 7 m and 8 m at OCR values of 1, 3 and 10

respectively. The consolidation procedure and the rate of shearing were the same as those described for the second TOA series of tests.

No additional DSST tests were performed by NGI on Drammen clay for this programme. Rather, use was made of previous tests performed in Drammen clay for a number of research projects. A selection of twelve tests was gathered from these projects, corresponding to the tests performed by TOA. In six of these tests (on both plastic and lean Drammen clay) the specimens were consolidated to in situ stresses using 4 load steps, over one day, with shear testing performed on the following day. Procedures of sample extrusion and preparation were similar. Average strain rate varied between 0.004 and 0.08 % per minute. In a further six tests specimens of plastic Drammen clay were first consolidated up to a maximum stress of 400kPa over one day, followed by unloading on the second day to a vertical stress corresponding to a predetermined OCR, with shear testing on the third day at a standard strain rate of about 0.08% per minute.

TESTS ON ARIAKE CLAY

Test results from the DSST and DST tests on Ariake clay are shown on Fig. 6. This includes the normalised stress at failure (τ_f/σ'_{v0}), the strain at failure (γ_f), the normalised large strain strength (τ_r/σ'_{v0}) and the rigidity index (G_{50}/τ_f). Failure in the DSST and the DST has been defined as the first point at which the maximum shear stress is attained. In traditional design shear strength parameters are sufficient to evaluate safety factor of stability. Currently numerical analyses, such as FEM, are becoming more popular and in these analyses some measure of shear stiffness (or rigidity) is needed. Therefore stiffness some stiffness data in the form of G_{50}/τ_f is also presented here. G_{50} corresponds to the secant shear modulus at 50% of the failure stress.

It is clear that the peak failure strengths from DSST are significantly lower than for the DST. Consistent with the discussion above, the difference in large strain strengths from the two tests is smaller, especially for the lower Ariake clay. The contribution of several factors to the observed differences in strength are now given consideration:

Sample Disturbance

Many techniques are available for the assessment of sample quality. These include X-ray photography, measurements of initial suction in the sample, comparison of shear wave velocity measured on the specimen with that obtained in situ and the assessment of the stress / strain curves and parameters measured in oedometer or triaxial tests (see for example Lunne et al. 1997, Hight et al., 1992).

Early work (e.g. Andresen and Kolstad, 1979) argued that the volumetric strain, ε_{vo} , induced when consolidating a sample back to the best estimate of in situ stresses was a useful indicator of sample quality. For a high quality sample ε_{vo} should be close to zero. Lunne et al. (1997) evaluated which soil parameters were most systematically influenced by sample disturbance. The conclusion was that the change in pore volume relative to the initial pore volume, $\Delta e/e_0$, is the best parameter to use, because it is reasonable to assume that a certain change in pore volume will be increasingly detrimental to the particle skeleton as the initial pore volume decreases. In this paper therefore use is made of the disturbance index $\Delta e/e_0$ rather than ε_{vo} . Over the last seven years NGI has used $\Delta e/e_0$ to evaluate sample disturbance on a number of onshore and offshore consulting projects according to the sample disturbance criteria given in Table 1. These criteria seem to have worked well in distinguishing between good and poor samples for OCR values below 3 - 4. Note for a particular clay multiply $\Delta e/e_0$ by $e_0/(1+e_0)$ to get the criteria in terms of ε_{vo} .

Values of $\Delta e/e_0$ during consolidation for DSST and DST are plotted in Fig. 7. For the upper clay, these data plot mostly in the “very good to excellent” or “good to fair” categories and there is a clear decrease in quality with depth. For the lower clay most of the specimens fall in the “very good to excellent” category and there is little difference in quality with depth. The TOA specimens are marginally better than the NGI samples (average $\Delta e/e_0 = 0.043$ compared to 0.046). It is evident however that the differences in $\Delta e/e_0$ between the DSST and DST do not clearly echo the differences in shear strength exhibited in Fig. 6. However, variations in the testing procedures will mask the effect of disturbance: firstly, at similar depths the consolidation stresses in the DSST were slightly higher. Secondly, the consolidation time was longer; ½ to one day for DSST compared to 10 minutes for DST.

An alternative assessment of disturbance is a comparison of the shear strains to failure as plotted in Fig. 6. Shear displacement in the DST has been converted to a shear strain, as discussed above. In this plot, a more consistent trend is apparent showing a slightly higher strain to failure for the DSST in all but one test. Qualitatively, this could be due to a larger degree of sample disturbance in the NGI samples, possibly caused by the air freight transportation.

Consolidation Time

The effect of consolidation time was studied by Berre (1985) who showed from constant volume DSS tests in Drammen clay that a consolidation time of 40 minutes resulted in a shear strength that was only 1.5% lower than a similar test performed with a consolidation time of 18 hours. However, from Fig. 6, the DST tests with the shorter consolidation times are exhibiting higher strengths than the DSST. Hence the effect of different consolidation times is considered less significant than other factors in assessing differences between DSST and DST.

Rate of Testing

Hanzawa et al. (1990) investigated the effect of strain rate on Ariake clay from K_0 consolidated triaxial compression tests on undisturbed samples. Their results are reproduced in Fig. 8. Although the actual strain rate along the failure plane (which would be comparable to strain rates in DST and DSST) will be different to the triaxial results shown in Fig. 8, the effect on the shear strength of tests carried out at strain rates of a different order of magnitude should be similar. The strain rate for the DST (1.25%/min) was approximately one order of magnitude higher than DSST (0.1%/min), and hence, from Fig. 8, the shear strengths for DST should be factored by about 0.88 in the upper clay and 0.86 in the lower clay to compare with the DSST results. The use of triaxial strain rates as a measure of rate effects in shear testing is arguable, and it should be noted that these correction factors are being applied in the absence of more appropriate shear test data.

Shearing Mechanism

As discussed above, Ohta et al.(1985) present an analysis which can be used to quantify the difference in shear strength between the DST and the DSST. Hanzawa et al. (1990) show that K_0 for Ariake clay above 12m is 0.54, and below 12m is 0.49. Also from Hanzawa et al. (1990) $\phi'_{(tc)}$ is estimated to be approximately 27° and 28° for the upper and lower clays respectively. (tc = triaxial compression). Hence from Fig. 3, the DST strengths should be factored 0.92 in the upper clay and 0.89 in the lower clay to compare with the DSST results.

Combining the effects of strain rate and the shearing mechanism, the DST strengths have been multiplied by a factor of 0.81 in the upper clay and 0.77 in the lower clay and compared to the DSST strengths in Fig. 9. The agreement is greatly improved. However, even the modified DST strengths are larger than the DSST

strengths. It is concluded that the remaining discrepancy is most likely due to differences in the quality of the soil samples, although it is also possible that the rate effects were, in fact, larger than estimated, or the correction factors of the Ohta et al. method were too small.

Correction used in practice

Hanzawa (1992) studied the shear strength values obtained from three tests for three different marine clays. His objective was to determine how best to obtain a value for mobilised shear strength (τ_{mob}) to be applied for example in design of embankments on soft ground. He concluded that in order to overcome the combined effects of disturbance, shearing rate and anisotropy, results from DST tests should be factored by 0.85 to give τ_{mob} .

Shear modulus

Comparison of shear moduli from DSST and DST depends, as discussed above, on the conversion of the shear displacement in the DST to an equivalent shear strain. Tang et al. (1994) argue that photographic results from a series of direct shear tests, performed by Takada (1993), verifies uniform specimen deformations up to τ_f . Values of G_{50} representing the secant shear modulus calculated at 50% of the maximum shear stress, normalised by τ_f (i.e. G_{50}/τ_f the rigidity index) are shown on Fig. 6. The two apparatuses appear to be in good agreement, including the detection of the more rigid behaviour at 15m depth. The average value of the rigidity index (excluding the test at 15m) for DSST is 97 while for DST at corresponding depths it is 110. This suggests that both are similarly sensitive to the combined effects of rate and shear mechanism.

TESTS ON DRAMMEN CLAY

Specimens consolidated to in situ stresses

A summary of test results from the DST and DSST on specimens of Drammen clay reconsolidated to in situ stresses is shown on Fig. 10. Somewhat fewer tests were available from the NGI sources than were performed by TOA. Nevertheless, a similar procedure of analysis has been adopted as was discussed above for Ariake clay. From Fig. 10 again it is clear that unmodified DST strengths are higher.

Sample Disturbance

Values of $\Delta e/e_0$ during consolidation for DSST and DST are plotted in Fig. 11. For the plastic Drammen clay, these data plot mostly in the “good to fair” category. As would be expected the quality of the lower plasticity lean clay specimens are worse and $\Delta e/e_0$ values for this material fall in the “poor” category. The average $\Delta e/e_0$ when consolidated to in situ stresses for DSST specimens in both plastic and lean Drammen clay is 0.07. In comparison, the average value for DST is 0.09 (not including the two highly disturbed specimens at 18 m to 19 m). Similarly, the average value of shear strains to failure for DSST is 3.1%, and for the DST it is 4.2%. This suggests that specimens tested by TOA were possibly somewhat more disturbed than those tested by NGI, i.e. the opposite to the finding for Ariake clay. Again this suggests some disturbance was caused during transportation by air freight.

Rate of Testing

In an early study of the DSST, Lucks et al. (1972) performed three direct simple shear tests on plastic Drammen clay using fast (0.12%/min), medium (0.011%/min) and slow (0.00036%/min) rates of strain. The specimens had been consolidated to in situ stresses. The shear strength ratios at failure of these three tests are plotted in Fig. 12 against the strain rate on a logarithmic scale. From the figure, it can be seen that

the change in strength with the logarithm of strain rate is approximately linear, and hence Fig. 12 can be used to give an approximate rate correction factor for each test, although this will involve an extrapolation to account for the strain rates used with the DST series. The shear strengths for both DSST and DST, therefore, have been corrected for a test with a standard strain rate of 0.1%/min.

Shear Mechanism

K_0 for both plastic and lean Drammen clay, determined from laboratory triaxial tests (Berre and Bjerrum, 1973) is 0.49. Plastic Drammen clay has $\phi'_{tc} = 25^\circ$ and for lean Drammen clay $\phi'_{tc} = 26^\circ$. Hence using the chart in Fig. 3, the DST strengths have been corrected by a factor of 0.87 in the plastic clay and 0.88 in the lean clay.

Combining the effects of both the rate of testing and the shear mechanism leads to corrected shear strengths as shown in Fig. 10. In this case, the corrected DSST strengths lie marginally above those for the DST. The small discrepancy is possibly due to the slightly greater disturbance shown in the DST specimens. On this evidence alone, the conclusion can be drawn that the causes for the sample disturbance in both the Ariake clay and the Drammen clay may be the result of sample transportation and handling (due to air freighting) as opposed to variations in the sample preparation, mounting and testing techniques.

Shear modulus

A comparison of the rigidity index, G_{50}/τ_f , is also made in Fig. 10, where it is evident that the rigidity of both the plastic and lean clays varies significantly with depth, reaching a maximum at about 12 to 15m depth. This trend is exhibited by both DST and DSST, but a closer examination of the differences in rigidity measured by the two apparatuses is difficult to make without further data. This similarity in results from both the DST and DSST tests was also found for Ariake clay (Fig. 6). However

it is unlikely that the coincidence of the results will apply to all clays, but will instead vary depending on the soil properties.

Specimens Consolidated to Predetermined OCRs

These tests involved both undisturbed and remoulded specimens of plastic Drammen clay, which were consolidated to about 400kPa and then unloaded to predetermined OCR values. This value is much higher than the in situ overburden stress and thus these series of tests are of value in determining whether the same corrections applied as to the tests on undisturbed specimens consolidated to in situ stresses. A comparison has been made of DST tests on undisturbed and remoulded specimens of Drammen plastic clay at OCR values of 1, 3 and 10, and the tests plots are shown in Fig. 13. It is clear that there is no consistent difference in the measured strengths or pore pressures for the three OCR values used. Note that here pore pressure is taken as the change in vertical stress required to maintain constant volume, as has been discussed above. It is concluded that at preconsolidation pressures of 400kPa any structural effects that may have been present in an undisturbed specimen have been removed. The consequence of this conclusion is that it should then be reasonable to compare directly the DSST results from undisturbed specimens with DST results from remoulded specimens.

Shear strength ratios at failure for DSST and DST are plotted against OCR in Fig. 14. It should be noted that most of the NGI DSST tests were performed on larger specimens (50cm² in area, 16mm height) than in the previous series. Before any corrections due to shearing mechanism or strain rate have been made, the results reveal that there is not a significant difference between the two tests. At low OCR values, namely 1 and 2, the DST gives slightly higher strengths than the DSST, however at OCR values of 3 and greater, the DSST shows slightly higher strengths.

This change in relative strength occurs approximately at the OCR value when the Drammen clay begins to exhibit negative rather than positive pore pressures at failure (Fig. 13). The analysis of Ohta et al. (1985) designed for correction for shearing mechanism between DST and DSST was originally intended for intact OCR = 1 to 2 clays. It is not clear whether it applies to larger OCR cases. Given the lack of an alternative the same approach as used above (i.e. determination of $1/\cosh\beta$ using Equations 3 to 6 and Figure 3) will be applied for illustrative purposes. Furthermore in the absence of reliable data, the correction for rate effects discussed above will also be applied. This correction corresponds to differences in rate of shear of about half an order of magnitude, leading to a correction factor of 0.93. The modified DST strengths are also plotted in Fig. 14. It can be seen that the DST and DSST strengths match well at OCR of 1, but otherwise the DSST strengths are somewhat higher.

Values of rigidity index G_{50}/τ_f for the range of OCR values tested are also shown in Fig. 14. Despite a consistent difference in stiffness between DST and DSST, probably due to the fundamental difference in the shearing mechanisms, the variation in stiffness with OCR is remarkably similar for the two tests.

CONCLUSIONS

The comparative study into the differences between the DST and the DSST has revealed the following conclusions:

1. For clays consolidated to in situ stresses, the direct shear test (DST) gives higher estimates of strength and stiffness than the direct simple shear test (DSST). The difference between the tests can be accounted for by the different shearing mechanism imposed to specimens, the different rates of strain used, and possibly some contribution due to different degrees of disturbance in the clay samples tested in Japan and Norway.

2. The different shearing mechanism between the DST and DSST can be quantified by adopting an analysis proposed by Ohta et al. (1985) formulated for K_0 consolidated clays under plane strain conditions using elasto-plastic constitutive equations.
3. The effect of performing tests at different rates of strain is difficult to compare accurately when assessing the DST. This is because there remains uncertainty in converting shear displacement to shear strain. Nevertheless, in Ariake clay, corrections based upon triaxial strain rates result in an improved agreement between DST and DSST strengths.
4. Evidence from the tests in Ariake and Drammen clay suggests that, after making appropriate corrections for the shearing mechanism and differences in rates of shear strain, some disturbance in the clay samples tested was apparent. Since this disturbance was more evident in the Ariake specimens tested in Norway and the Drammen specimens tested in Japan, it is tentatively concluded that the transportation and handling of samples was the primary cause of any such disturbance.
5. Direct shear tests on undisturbed and remoulded specimens that had first been consolidated up to stresses of 400kPa resulted in stress strain plots and strengths that were almost identical. Hence, it is concluded that after experiencing such high stresses, the effects of sample disturbance and in situ structure in the clay were eradicated. Comparisons between undisturbed direct simple shear tests and remoulded direct shear tests were therefore considered valid.
6. After making corrections for differences in the shearing mechanism and rate effects in the DST and DSST, shear strengths were similar for OCR values of 1 and 2. For OCR values of 3 and greater (which, in fact, corresponded

approximately to the OCR values where pore pressures at failure became negative), the DSST gave somewhat greater strengths. Variations in stiffness for the range of OCR values tested were remarkably similar.

7. It should be noted that the modifying factors presented here, which are used for DSST / DST comparative purposes, are not necessarily applicable to practical strength determination in Japan. In the author's experience, and as detailed in Hanzawa (1992), DST shear strengths are actually used in design by multiplying by an overall correction factor of 0.85.

REFERENCES

- Airey, D.W. and Wood, D.M. (1987): An evaluation of direct simple shear tests on clay. *Geotechnique*, **37** (1), 25-35.
- Andresen, A. and Kolstad, P. (1979): The NGI 54mm samplers for undisturbed sampling of clays and representative sampling of coarse material. *Proc., International Symposium, Singapore*, 13-21. Also in *NGI Publication No. 130*.
- Berre, T. (1985): Effect of consolidation time on triaxial and direct simple shear tests. *NGI Internal Report*, No. 56103-29.
- Berre, T. and Bjerrum, L. (1973): Shear strength of normally consolidated clays. *Proc. 8th Int. Conf. Soil Mechanics and Foundation Engineering*, Moscow, **1.1**, 39-40.
- Bjerrum, L. (1973): Problems of soil mechanics and construction on soft clay. *Proc. 8th Int. Conf. Soil Mechanics and Foundation Engineering*, Moscow, **3**, 109-159.
- Bjerrum, L. and Landva, A. (1966): Direct simple shear tests on a Norwegian quick clay. *Geotechnique*, **16** (1), 1-20.
- Borin, D.L. (1973): The behaviour of saturated kaolin in the simple shear apparatus. *PhD thesis*, University of Cambridge.

de Josselin de Jong, G. (1972): Discussion, *Proc. Roscoe Memorial Symp. Stress-Strain Behaviour of Soils*, Cambridge, 258-261.

Dyvik, R., Berre, T., Lacasse, S. and Raadim, B. (1987): Comparison of truly undrained and constant volume direct simple shear tests. *Geotechnique*, **37** (1), 3-10.

Hanzawa, H., Fukaya, T. and Suzuki, K. (1990): Evaluation of engineering properties for an Ariake clay. *Soils and Foundations*, **30** (4), 11-24.

Hanzawa, H. (1992): A new approach to determine soil parameters free from regional variations in soil behaviour and technical quality. *Soils and Foundations*, **32** (1), 71 – 84.

Hight, D.W., Boese, R., Butcher, A.P., Clayton, C.R.I. and Smith, P.R. (1992): Disturbance of the Bothkennar clay prior to laboratory testing. *Geotechnique*, **42** (2), 199-217

Ladd, C.C. (1973): Discussion, main session, *8th Int. Conf. Soil Mechanics and Foundation Engineering*, Moscow, **4**, 108-115.

Ladd, C.C. and Edgers, L. (1972): Consolidated undrained direct simple shear tests on saturated clays. *MIT Research Report*, R72-82.

Lucks, A.S., Christian, J.T., Brandow, G.E. and Høeg, K. (1972): Stress conditions in NGI simple shear test. *Jnl. Soil Mech. Fdns. Div. ASCE*, **98** (SM1), 155-160.

Lunne, T., Eide, O. and de Ruiter, J. (1976): Correlations between cone resistance and vane shear strength in some Scandinavian soft to medium clays. *Canadian Geotechnical Journal*, **13** (4), 430-441.

Lunne, T., Berre, T. and Strandvik, S. (1997): Sample disturbance effects in soft low plastic Norwegian clay. *Proc., Recent Developments in Soil and Pavement Mechanics*, Brazil, June, 81-102.

- Lunne, T. and Lacasse, S. (1999): Geotechnical characteristics of low plasticity Drammen clay. *Characterisation of soft marine clays*, Tsuchida and Nakase (eds), Balkema Rotterdam, 33-56.
- Morgenstern, N.R. and Tchalenko, J.S. (1967): Microscopic structures in kaolin subjected to direct shear. *Geotechnique*, **17** (4), 309-328.
- Ohta, H., Nishihara, A. and Morita, Y. (1985): Undrained stability of K_0 consolidated clays. *Proc. 11th Int. Conf. Soil Mechanics and Foundation Engineering*, San Francisco, **2**, 613-616.
- Ohtsubo, M., Egashira, K., Kashima, K. (1995): Depositional and post-depositional geochemistry, and its correlation with the geotechnical properties of marine clay in Ariake bay, Japan, *Geotechnique*, **45** (3), 509-523
- Potts, D.M., Dounias, G.T. and Vaughan, P.R. (1987): Finite element analysis of the direct shear box test. *Geotechnique*, **37** (1), 11-23.
- Saada, A.S. and Townsend, F.C. (1981): State of the art: laboratory strength testing of soils. *ASTM Spec. Tech. Publ.*, No. 740, 7-77.
- Takada, N. (1993): Mikasa's Direct Shear Apparatus, test procedures and results. *Geotechnical Testing Journal*, **16** (3), 314-322.
- Tanaka, H., Sharma, P., Tsuchida, T. and Tanaka, M. (1996): Comparative study on sample quality using several different types of samplers. *Soils and Foundations*, **36** (2), 67 - 68.
- Tang, Y.X., Hanzawa, H. and Yasuhara, K. (1994): Direct shear and direct simple shear test results on a Japanese marine clay. *IS-Hokkaido'94*
- Tsuji, K., Tang, Y.X. and Lunne, T. (1998): A comparative study on shear strength of marine clays by direct shear and direct simple shear test. *Journal of Geotechnical Engineering, JSCE*, **589** (III-42), 275 – 285 (In Japanese).

Vucetic, M. and Lacasse, S. (1982): Specimen size effect in simple shear test. *Jnl. Geotech. Eng. Div. ASCE*, **108** (GT12), 1567-1585.

Wright, D.K., Gilbert, P.A. and Saada, A.S. (1978): Shear devices for determining dynamic soil properties. *Proc. Spec. Conf. Earthquake Engineering and Soil Dynamics*, ASCE, Pasadena, **2**, 1056-1075.

Wroth, C.P. (1984): The interpretation of in situ soil tests. 24th Rankine Lecture. *Geotechnique*, **34** (4), 449-489.

Wroth, C.P. (1987): The behaviour of normally consolidated clay as observed in undrained direct shear tests. *Geotechnique*, **37** (1), 37-43.

Table 1 Criteria for evaluation of sample disturbance (Lunne et al. 1997)

Overconsolidation ratio, OCR	$\Delta e/e_o$			
	Very good to excellent*	Good to fair*	Poor*	Very poor*
1 – 2	<0.04	0.04-0.07	0.07-0.14	>0.14
2 – 4	<0.03	0.03-0.05	0.05-0.10	>0.10

*The description refers to the use of the samples for measurement of mechanical properties.

Figure List

Fig. No.	Title	Ref.
1	Conditions of (a) direct simple shear and (b) direct shear	Dell/Papers/Hanzawa/Fig1.xls
2	Possible failure mechanism during shear (a) horizontal planes (b) vertical planes	D(AD)/Hanzawa/FailuremodeParsAnadb.jpg
3	Theoretical relationship between undrained shear strength DSST and DST	Dell/Papers/Hanzawa/Fig7.xls+Coshbeta.grf
4	Basic physical properties and degree of overconsolidation of Ariake clay	D(AD)/Hanzawa/Ariakebasics.jpg
5	Soil profile at Drammen Museum Park / Danvikgata site	Dell+D(AD)/Papers/Hanzawa//Drammenbasics.grf
6	Shear strength and stiffness data for DSST and DST tests in Ariake clay	Dell/Papers/Hanzawa/Ariakesu.xls+.grf
7	Assessment of sample quality of Ariake clay samples using quality criteria of Lunne et al., 1997	Dell/Papers/Hanzawa/Ariakequality.grf
8	Effects of strain rate for K_0 consolidated triaxial tests on Ariake clay	Dell/Papers/Hanzawa/Strainrate.grf+.xls
9	Normalised strengths from DSST, DST and DST modified to take into account strain rate and shearing mechanism effects for Ariake clay	Dell/Papers/Hanzawa/Ariakesumodified.grf
10	Shear strength and stiffness data for DSST and DST tests in Drammen clay	Dell/Papers/Hanzawa/Ariakesu.xls+Drammensu.grf
11	Assessment of sample quality of Drammen clay samples using quality criteria of Lunne et al., 1997	Dell/Papers/Hanzawa/Drammenquality.grf
12	Effect of strain rate on the DSST shear strength ratio of Drammen clay (NGI, 1972)	Dell/Papers/Hanzawa/RATE.xls
13	Comparison of DST tests on remoulded and undisturbed specimens of plastic Drammen clay.	Dell/Papers/Hanzawa/Remouildvundisturb.grf+.xls
14	Comparison of shear strength ratio at failure and rigidity index for overconsolidated specimens of plastic Drammen clay.	Dell/Papers/Hanzawa/DrammenOCRsum.grf+.xls

Figures for paper: A comparative study between the NGI direct simple shear apparatus and the Mikasa direct shear apparatus by Hanzawa et al.

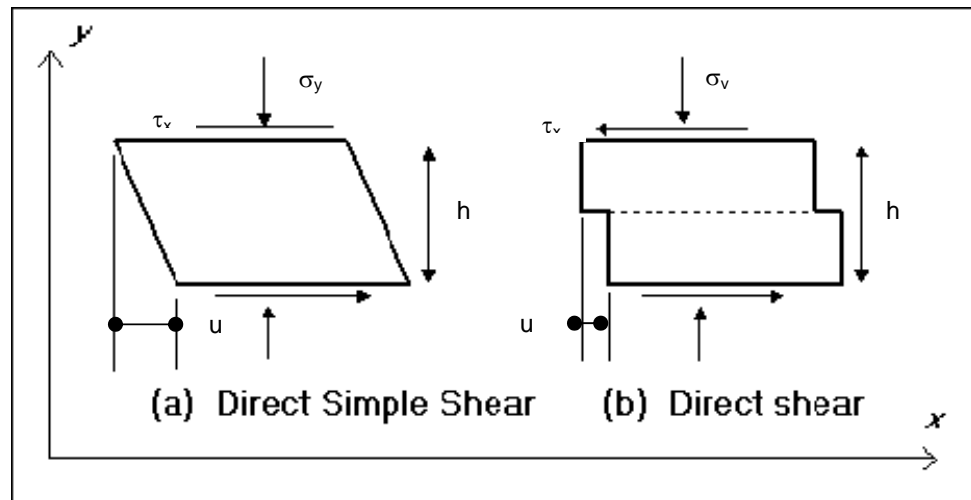

Fig. 1. Conditions of (a) direct simple shear and (b) direct shear

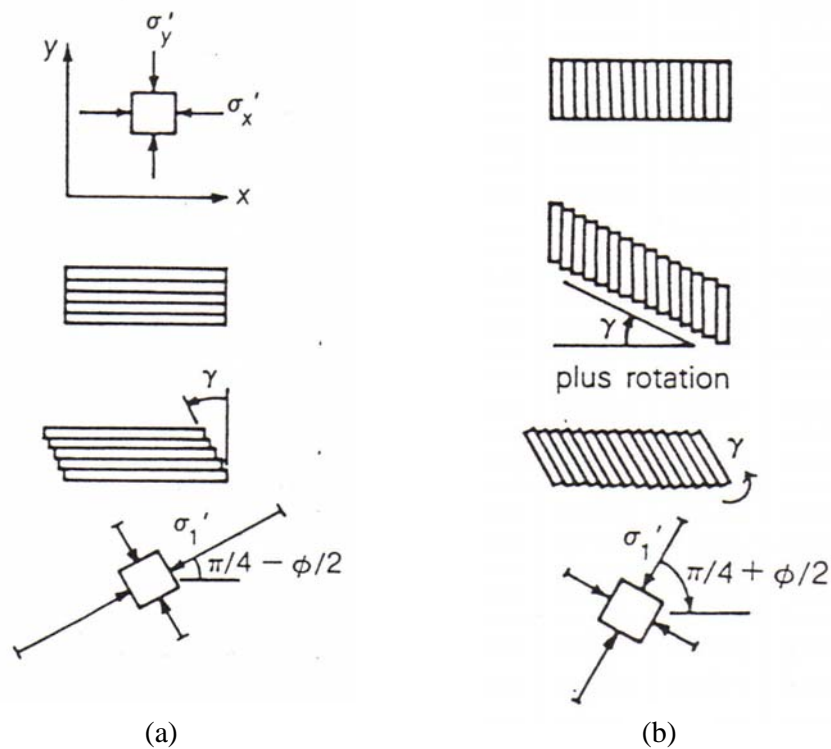

Fig. 2. Two possible mechanisms which can occur during shear; (a) one of translation along a series of horizontal planes, or (b) one of translation along vertical planes with an associated rotation of those planes (Josselin de Jong, 1972 and Wroth, 1984)

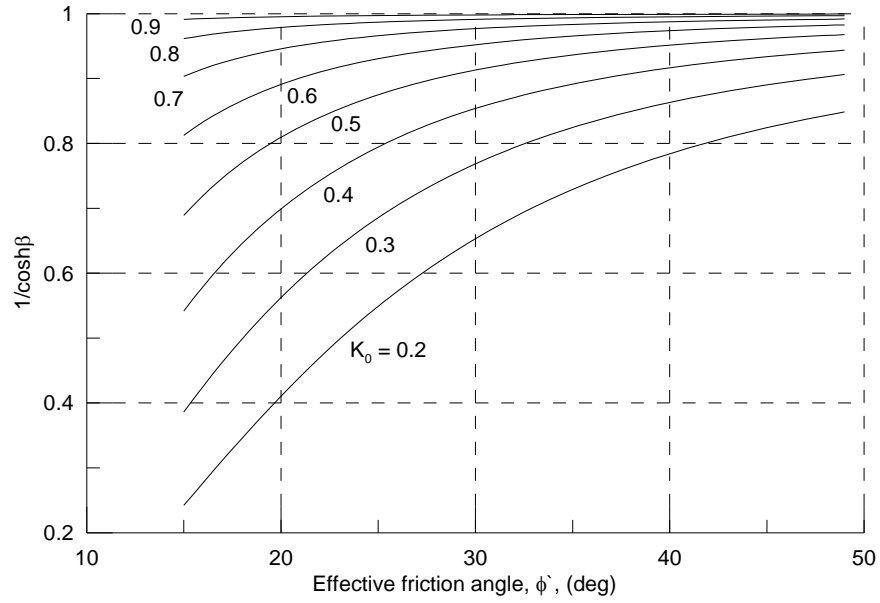

Fig. 3. Theoretical relationship between undrained shear strength DSST and DST (Ohta et al. (1985))

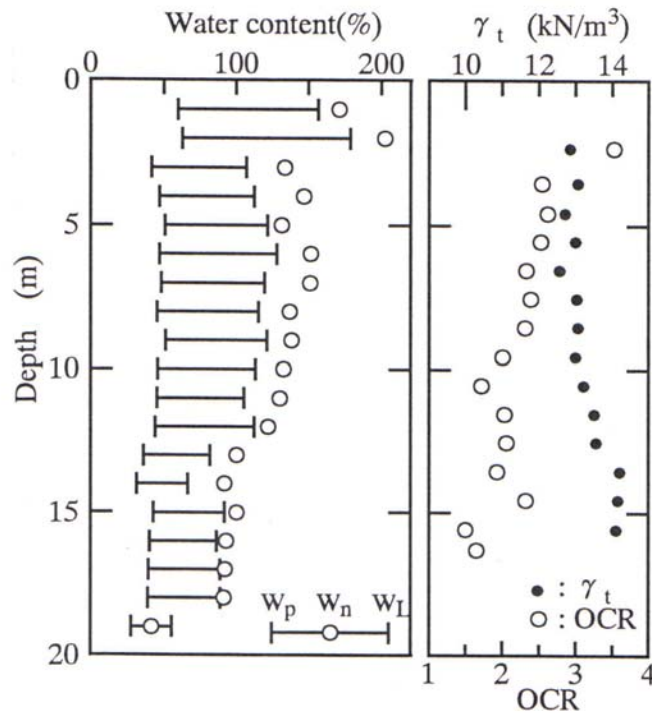

Fig. 4. Basic physical properties and degree of overconsolidation of Ariake clay (Tang et al., 1994)

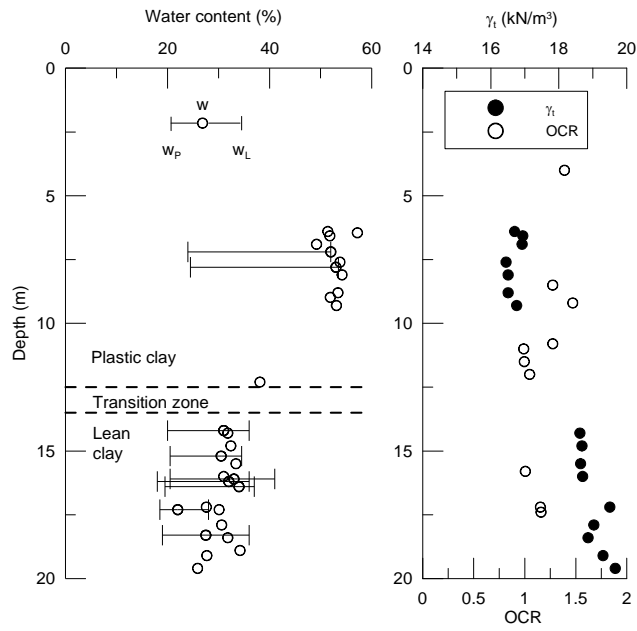

Fig. 5. Soil profile at Drammen Museum Park / Danvikgata site (Lunne et al., 1976, Lunne and Lacasse, 1999)

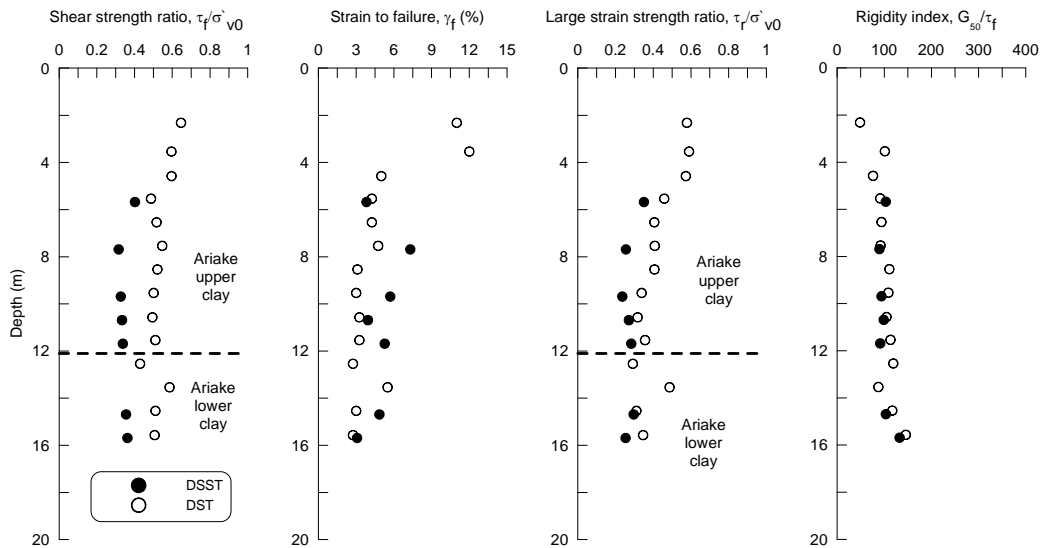

Fig. 6. Shear strength and stiffness data for DSST and DST tests in Ariake clay

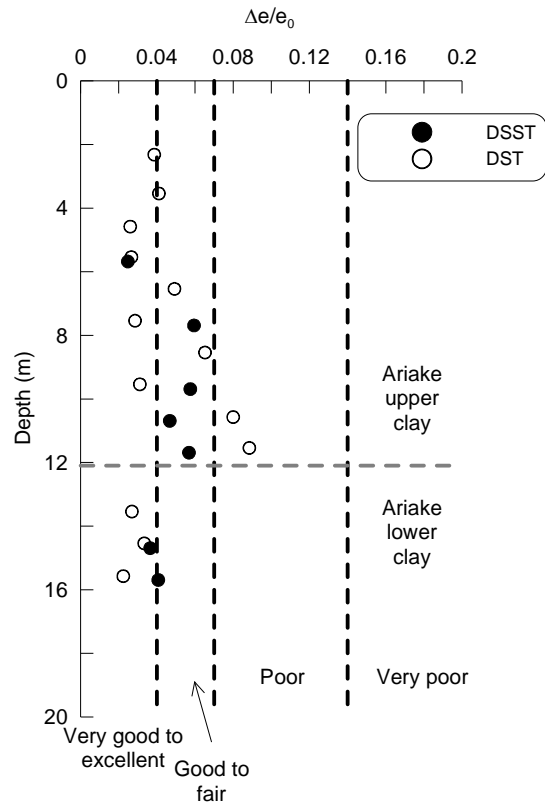

Fig. 7. Assessment of sample quality for Ariake clay using NGI criteria of Lunne et al. (1997)

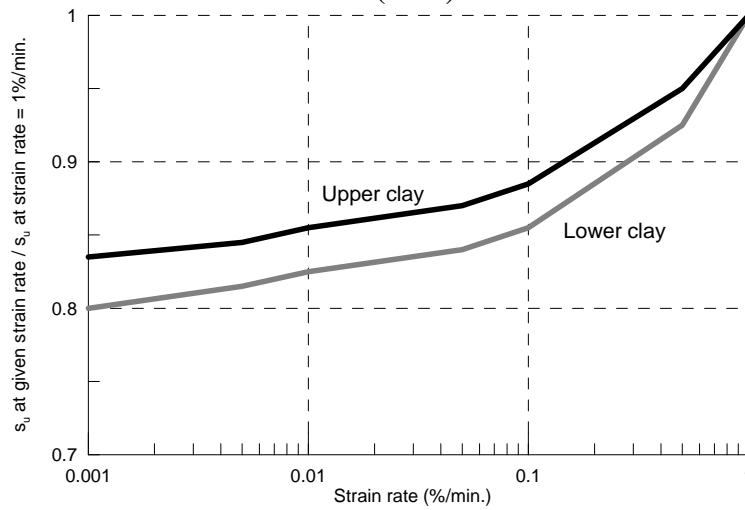

Fig. 8. Influence of strain rate for K_0 consolidated triaxial tests on Ariake clay (Hanzawa et al., 1990)

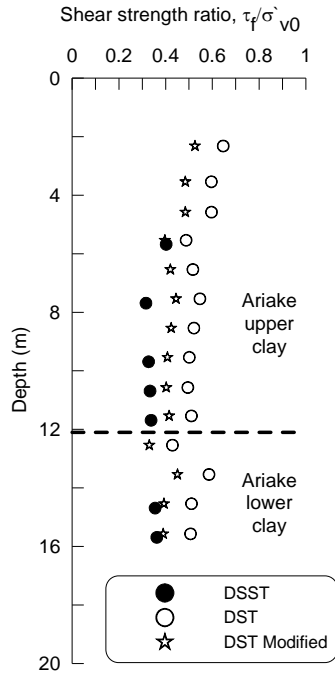

Fig. 9. Shear strength ratios from DSST, DST and DST modified to take into account strain rate and shearing mechanism effects for Ariake clay

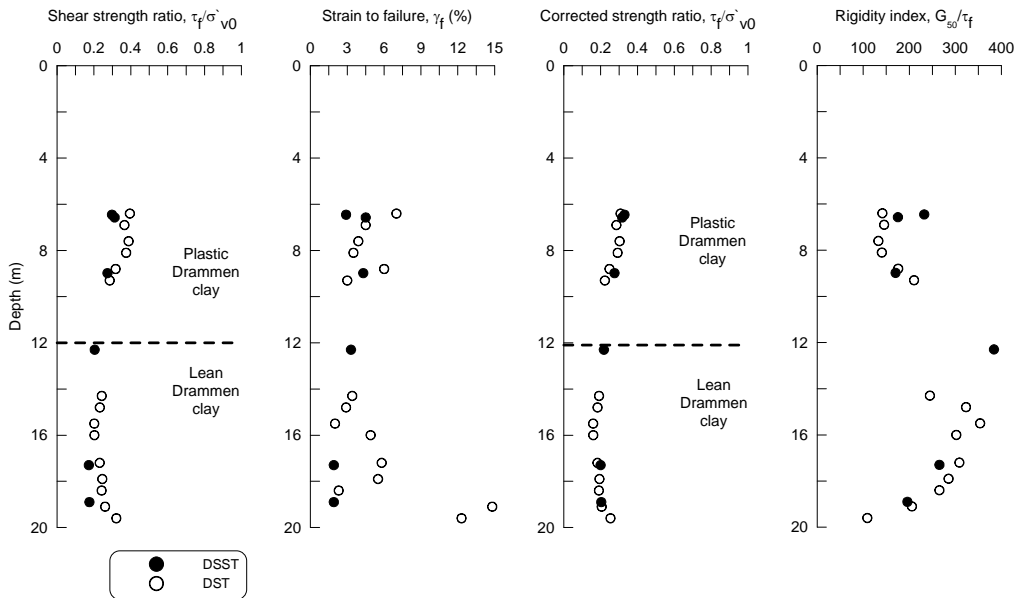

Fig. 10. Shear strength and stiffness data for DSST and DST tests in Drammen clay

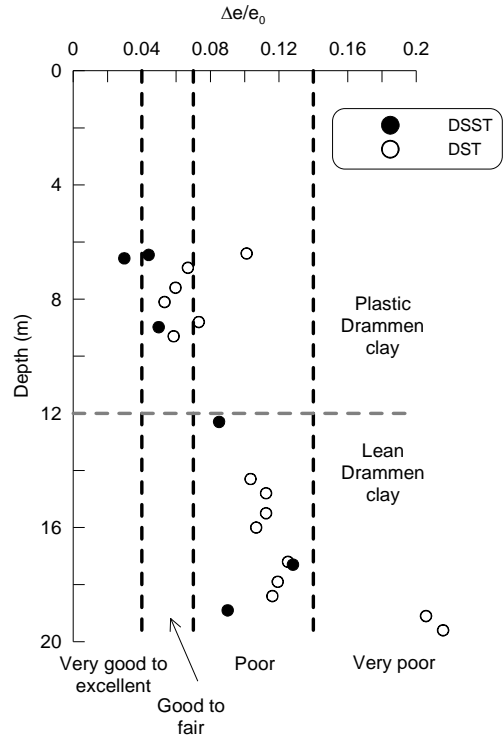

Fig. 11. Assessment of sample quality for Drammen clay using NGI criteria of Lunne et al. (1997)

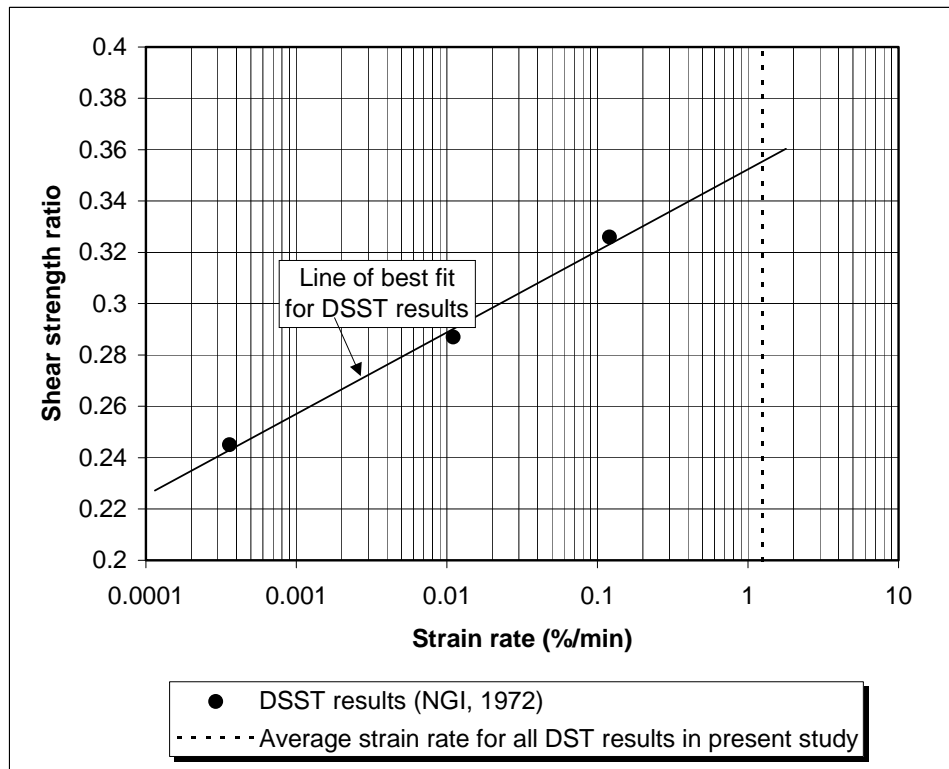

Fig. 12. Effect of strain rate on the DSST shear strength ratio of Drammen clay (NGI, 1972).

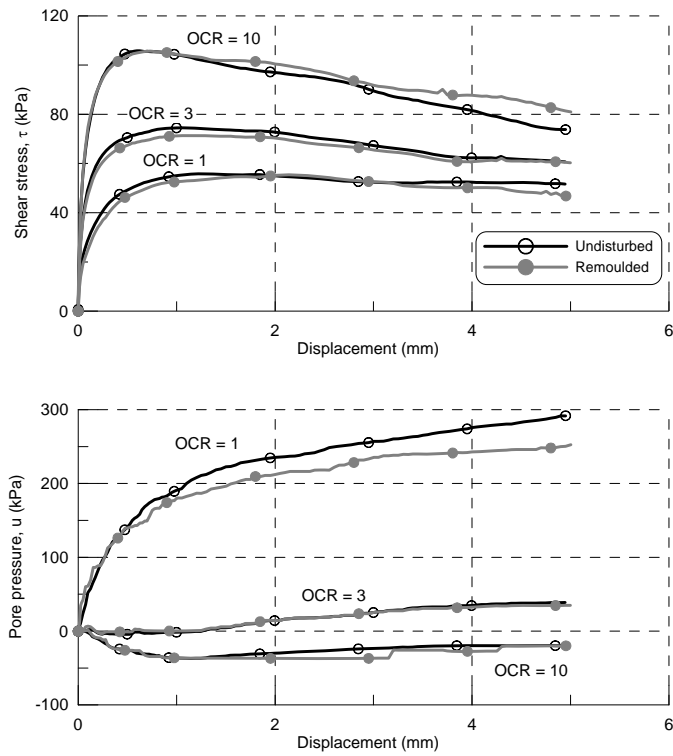

Fig. 13. Comparison of DST tests on remoulded and undisturbed specimens of plastic Drammen clay.

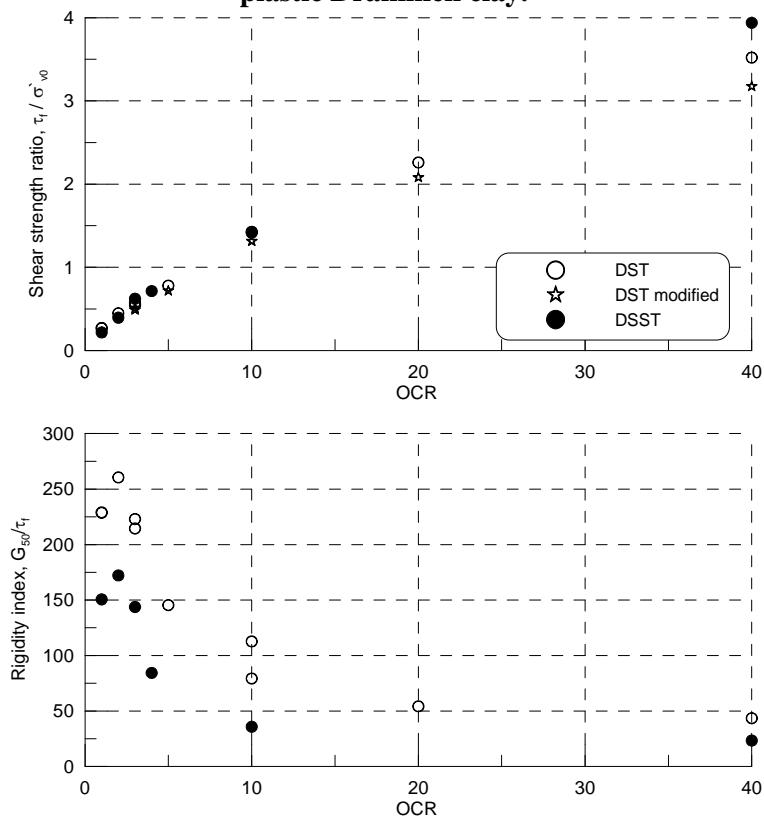

Fig. 14. Comparison of shear strength ratio at failure and rigidity index for overconsolidated specimens of plastic Drammen clay.