

VIABILITY OF OLD HOUSE BORER (*HYLOTRUPES BAJULUS*) LARVAE EXPOSED TO A CONSTANT MAGNETIC FIELD OF 98 MT UNDER LABORATORY CONDITIONS

SNEŽANA RAUŠ, DAJANA TODOROVIĆ, and Z. PROLIĆ

Laboratory of Magnetobiology and Behavior, Siniša Stanković Institute for Biological Research, 11060 Belgrade, Serbia

Abstract — The purpose of our experiment was to establish how exposure to a constant magnetic field of 98 mT affects behavior in terms of viability and larval mass of the old house borer (*Hylotrupes bajulus* L.). It is demonstrated that larvae exposed to this magnetic field show statistically significant higher viability, as well as a tendency of mass increase in comparison with the control group. These results can be attributed to the modulatory effect of the employed external magnetic field on metabolism and neurohumoral regulation in the insects.

Key words: Magnetic field, viability, development, *Hylotrupes bajulus*

UDC 595.768.1:591.1:591.5

INTRODUCTION

From its very beginnings, life has been exposed to the impact of the Earth's magnetic field (EMF), in whose presence the phylogeny of organisms took place. Technological development, especially since the middle of the 20th century, brought with it a host of devices that have wide applications and emit additional electromagnetic radiation into the environment. This increases the need for research on the biological effects of individual components of the given ecophysiological factor.

In the past few decades, it became completely clear that biological systems are sensitive to even very weak external magnetic fields (Adey, 1981; Gould, 1984; Cain et al., 1987). A series of investigations has in several recent years been devoted to the impact of magnetic fields (MF) on biological systems, both at the level of atoms and molecules, and at higher levels of biological organization. One of the organisms that lent itself as suitable for testing the impact of constant magnetic fields (CMF) on life functions is the old house borer *Hylotrupes bajulus* L. Larvae of this species are one of the most severe pests in coniferous forests. They are mostly found on pine, fir, and spruce trees, feeding on tree mass. They can also be found in infected lumber in

stored material, beams, wooden stairs, and floors (Kovačević, 1956). This species does not accept the standard substrate for laboratory rearing of some species of the family Cerambycidae, so the test we applied is essentially a test of their viability under conditions of starvation.

The purpose of the present work was to establish the impact of a constant 98-mT magnetic field on behavior of the old house borer *Hylotrupes bajulus* in terms of viability and change in larval mass. Such research should shed light on the effects of an omnipresent ecophysiological factor on the biology and abundance of this species.

MATERIALS AND METHODS

The adult body of *H. bajulus* (Fig. 1) is 8 to 20 mm long, brown in color, and covered with tiny gray hairs, which are longer at the neck shield and legs. At the neck shield there are two naked shiny bulges. Two white narrow stripes run across the elytra. Adults emerge in summer. The females lay eggs in splits or cracks of a tree, in groups of 50 to 150. After 2 to 3 weeks, the larvae hatch and immediately penetrate the tree's wood.

Larvae of the old house borer *Hylotrupes bajulus*

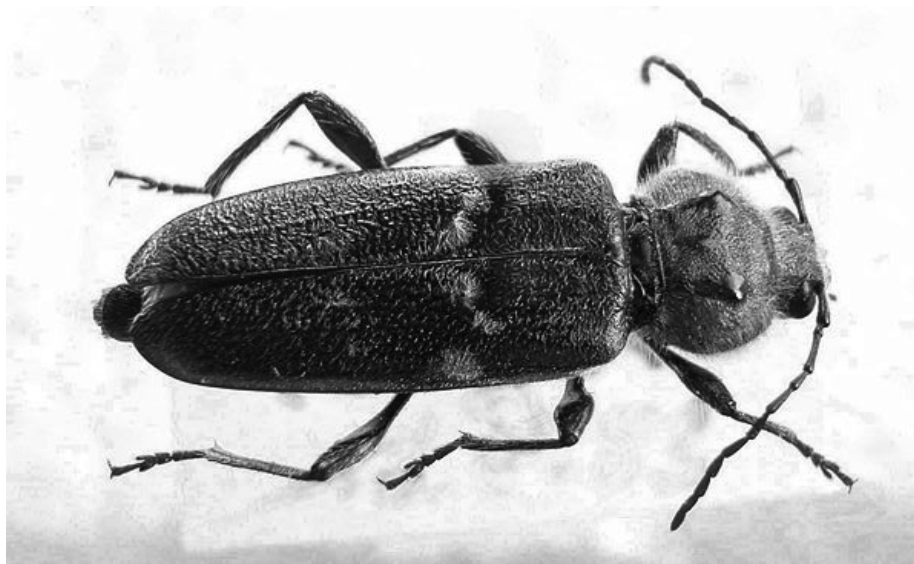

Fig. 1. Adult of old house borer *H. bajulus*.

L. were used in the experiment. The larvae have a pale yellow color and stunted extremities. They move with the aid of seven abdominal nipples and bulges on their bodies. Adult larvae are ca. 30 mm long. Larval development may last 3 to 4 years, but also several decades, depending on the physiological state of the tree, primarily temperature and humidity.

Larvae (N = 20) taken from fir tree lumber (a roof beam) originating from Mt. Tara, Western Serbia, were removed to laboratory conditions: temperature of $23 \pm 1^\circ\text{C}$, relative humidity of $78 \pm 10\%$, and light regime of 12 h day/12 h night. Light intensity was around 100 lx.

The initial larval mass was on average 95 to 135 mg per larva. The larvae were randomly divided into two groups of 10 larvae each. They were then placed individually in glass Petri dishes (50 mm in diameter and 22 mm in height) filled with nutrient substrate. The nutrient substrate was a mixture of water, sugar, cornmeal, agar, and a mass chips of the same tree, cooked for 6 to 8 minutes and cooled to room temperature. The larvae spent 24 h on this substrate for feeding control, i.e., to test substrate acceptance. It was established that only 40% of larvae in each group consumed the substrate offered in minimal amounts.

A magnetic field was formed by a pair of permanent horseshoe magnets forming a relatively homogeneous constant magnetic field within their poles (Fig. 2). The distance between the poles was 68 mm, and the average value of the magnetic field in this space was 98.29 ± 11.75 mT. Magnetic induction in the space where the larvae were placed was measured with a GM05 magnetometer from Hirst Magnetic Instruments Ltd., probe PT 2837.

The experimental group of 10 individuals in Petri dishes was placed in the magnetic field, while the control group of 10 individuals in Petri dishes was placed at a distance where the magnetic field was at the level of EMF. The larval mass was measured every 10th day while the larvae were alive (130 days in the control group, 160 days in the CMF group). The results obtained from these measurements were compared by the Student t-test (for two independent groups). Larval viability was also monitored and analyzed by the Z-test.

RESULTS

It can be seen in Figs. 3 and 4 that the group exposed to a CMF of 98 mT showed better viability, which resulted in an increase of the total average mass and life span. In the control group, larval mass

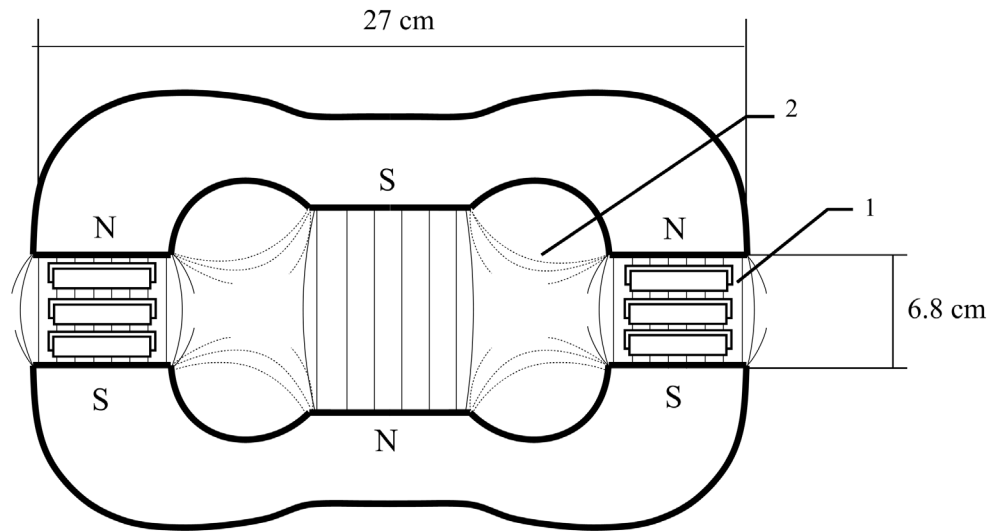

Fig. 2. Magnetic field exposure system. 1 – relatively homogenous magnetic field with average magnetic induction of 98 mT where samples are placed; 2 – inhomogenous magnetic field.

stagnated until day 80. After this, the average larval mass decreased until the last individual in the group died. Average larval mass in the CMF group showed a trend of slight increase until day 90, after which it started to decrease, which was especially expressed after day 110. Comparison of larval mass changes revealed no statistically significant differences between the control group and larvae exposed to the CMF.

In contrast to body mass, the results obtained on larval viability showed statistically significant differences between the control and treated groups on days 50 ($Z = 3.162$, $p < 0.01$), 60 ($Z = 2.190$, $p < 0.05$), 110 ($Z = 1.989$, $p < 0.05$), and 120 ($Z = 2.760$, $p < 0.01$), higher viability being found in the group exposed to a CMF of 98 mT (Fig. 4). The last larvae in the MF die as late as 30 days after death of the last larva in control, i.e., they live for 160 days.

DISCUSSION

The results indicate that *H. bajulus* larvae show statistically significant higher viability when exposed to a CMF of 98 mT. It was also observed that the last larvae exposed to the CMF die as late 30 days after death of the last larva in the control. In addition to this, the individual mass of larvae exposed

to the CMF increased until day 90, but without statistically significant differences compared to the control. After this period, a decrease of mass was observed, but that change was slower than in the control group.

There is much evidence indicating that a magnetic field affects the development and viability of various insects. In *Drosophila melanogaster*, after exposure to a CMF of 130 mT to 180 mT, changes in genetic material were observed within viability categories through three consecutive generations (Prolić and Anđelković, 1992). A constant magnetic field of 375 mT stimulates development of workers in the pupal stage (Prolić and Jovanović, 1986). Similar results were obtained by Prolić and Nenadović (1995), who found that development of *Tenebrio molitor* was affected by a magnetic field of similar characteristics (320 mT), metamorphosis of pupae into adults being 14% faster in the presence of the magnetic field. On the other hand, the metamorphosis of pupae of the housefly *Musca domestica* exposed to an extremely low-frequency magnetic field (50 Hz, 6 mT) was significantly slowed at temperatures of 19 and 24°C. The life span of an adult in a magnetic field with these characteristics is significantly extended at a temperature of 24°C compared

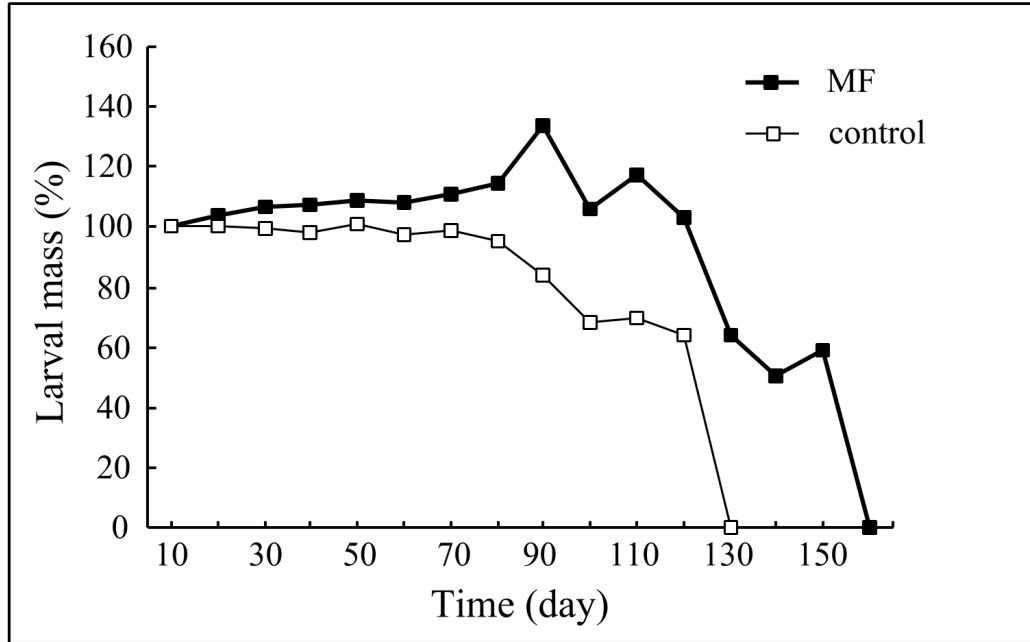

Fig. 3. Influence of a constant magnetic field (98 mT) on larval mass.

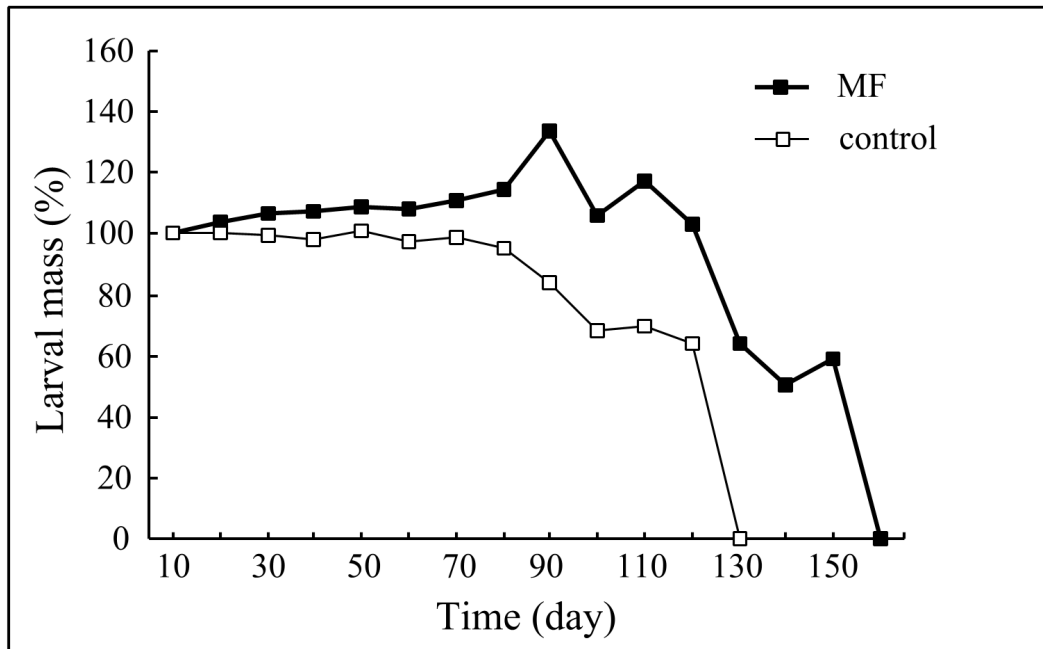

Fig. 4. Influence of a constant magnetic field (98 mT) on larval viability. * $p < 0.05$ and ** $p < 0.01$ indicate significant differences compared to the control (Z test).

to the control (Stanojević et al., 2005).

Viability of phytophagous insects, to which category *H. bajulus* belongs, depends on a number of abiotic factors, such as temperature, humidity, and interaction of temperature and nitrogen content in food (Lindroth et al., 1997; Ivanović and Nenadović, 1999); plant protein quality (Broadway and Duffey, 1988; Felton et al., 1989); and the balance of amino acids in proteins. Starving or inadequate food affects the physiology of all cells in various ways via fine molecular mechanisms, disrupting the dynamic equilibrium of basic biological processes. The response of insects during development on inadequate food is very similar to their response to unfavorable temperatures (slowing of development, delay of metamorphosis due to numerous moltings). The response of insects to unfavorable temperature and food is associated with reaction at the level of the endocrine system, i.e., hormones that control development. Absence of food in *Bombyx mori* slows larval development (Panov, 1966). Inadequate substrate in some *Galleria mellonella* larvae at the initial stages inhibits metamorphosis, whereas other larvae of this species molt several times (Bogus and Wolbert, 1987). In gypsy moths reared from egg to imago on locust leaves (which have lower protein and free sugar contents than oak leaves, but contain more tannin, flavonoids, and alkaloids), larval development is extended, with significant increase in the activity and number of different types of neurosecretory neurons of the medial group (Perić-Mataruga, 1997). One possible way of explaining our present results is to postulate a modulatory effect of hormones released from neurosecretory neurons of *H. bajulus* brain ganglions.

It has already been shown that a CMF with average induction of 320 mT affects cytological characteristics and activity of protocerebral mediodorsal A2 neurosecretory neurons in *Tenebrio molitor* (Perić-Mataruga et al., 2006). Upon exposure of *T. molitor* pupae to this magnetic field, a significant increase in A2 neurosecretory neurons and their nucleoli was observed, which indicates intensive synthesis of neurosecretory material. Neurohormones released from these cells are involved in regulation of metabolism and can influence the concentrations of pro-

teins, lipids, and sugars, as well as overall metabolism, and consequently affect viability. In addition, an extremely low-frequency magnetic field (50 Hz, 20 mT average induction) also changes the activity of medial protocerebral neurosecretory neurons and *corpora allata* in *Cerambyx cerdo* larvae. In these larvae, after 30 days of exposure, such a magnetic field causes a decrease of neurosecretory A1 and A2 neuron activity, while the activity of *corpora allata* is increased (Nenadović et al., 2005).

Initial increase in larval mass of *H. bajulus* reared on a protein-rich substrate and exposed to a 98-mT CMF could be attributable to the field's effect on metabolism. It has already been shown that when the cerambycid beetle *Morimus funereus* is reared on an artificial diet much richer in proteins than tree mass, protein metabolism is activated and proteolytic activity is increased, as in body mass (Ivanović and Nenadović, 1999). In *H. bajulus* (which belongs to the same family), this mechanism is not applicable, given that, according to our results, larvae of this species only moderately accept the substrate. Thus, a possible explanation of our results could be that the MF exerts direct or indirect (via octopamine neurohormone) influence on carbohydrate metabolism. Further research is needed to confirm this.

We can conclude that the applied MF, whose intensity is many (> 4000) times higher than that of the Earth's magnetic field (to which the insects are constantly exposed), can be considered to be a stressogenic factor. The effects observed in terms of viability and larval mass of *H. bajulus* could be attributable to changes at the level of the neuroendocrine system and metabolism. However, to confirm this hypothesis, additional research is needed, which might also yield a histological explanation of possible mechanisms governing external MF influences.

Acknowledgment — This work was supported by the Ministry of Science of the Republic of Serbia (Grant 143027).

REFERENCES

- Adey, W. R. (1981). Tissue interactions with nonionizing electromagnetic fields. *Physiol. Rev.* **61** (2), 435-514.
- Bogus, M. I., and P. Wolbert (1987). Diet influences *Galleria mellonella* development and sensitivity to juveniling

- treatments. *Zool. Jahrb. Abt. Allg. Zool. Physiol. Tiere* **91** (2), 211-220.
- Broasway, R. M., and S. S. Duffey (1988). The effect of plant protein quality on insect digestive physiology and the toxicity of plant proteinase inhibitors. *J. Insect Physiol.* **34**, 1111-1117.
- Cain, C. D., Adey, W. R., and R. A. Luben (1987). Evidence that pulsed electromagnetic fields inhibit coupling of adenylate cyclase by parathyroid hormone in bone cells. *J. Bone Miner. Res.* **2**(5), 437-441.
- Felton, G. W., Broadway, R. M., and S. S. Duffey (1989). Inactivation of protease inhibitor activity by plant-derived quinones: complications for host-plant resistance against noctuid herbivores. *J. Insect Physiol.* **35**, 981-990.
- Gould, J. L. (1984). Magnetic field sensitivity in animals. *Annu. Rev. Physiol.* **46**, 585-598.
- Ivanović, J., and V. Nenadović (1999). Uticaj hrane i temperature na životni ciklus fitofagnih insekata. *Pesticidi* **14**, 309-328.
- Kovačević, Ž. (1956). *Primijenjena entomologija. III. Šumski štetnici*. Poljoprivredni nakladni zavod, Zagreb.
- Lindroth, R. L., Klein, K. A., Hemming, J. D. C., and A. M. Feuker (1997). Variation in temperature and dietary nitrogen affect performance of the gypsy moth, *Lymantria dispar* L. *Physiol. Entomol.* **22** (1), 55-64.
- Nenadović, V., Mrdaković, M., Lazarević, J., Mirčić, D., Todorović, D., and Z. Prolić (2005). Temperature and magnetic field effects on the activity of protocerebral neurosecretory neurons and corpora allata in *Cerambyx cerdo* L. larvae. *Arch. Biol. Sci. (Belgrade)* **57** (1), 19-24.
- Panov, A. A. (1966). Neurosecretory cells in the brain of silkworm and their reaction to starvation. *Dokl. Akad. Nauk SSSR* **170** (4), 952-955.
- Perić-Mataruga, V. (1997). *Activity of Enzymes of the Antioxidative System and That of Protocerebral Neurosecretory Cells in Lymantria dispar L. Caterpillars from Different Populations under Conditions of Nutritional Stress*. Doctoral Dissertation, Faculty of Biology, University of Belgrade, Belgrade.
- Perić-Mataruga, V., Prolić, Z., Nenadović, V., Mrdaković, M., and M. Vlahović (2006). Protocerebral mediodorsal A2' neurosecretory neurons in late pupae of yellow mealworm (*Tenebrio molitor*) after exposure to a static magnetic field. *Electromagn. Biol. Med.* **25**, 127-133.
- Prolić, Z., and V. Nenadović (1995). The influence of a permanent magnetic field on the process of adult emergence in *Tenebrio molitor*. *J. Insect Physiol.* **41**, 1113-1118.
- Prolić, Z., and Z. Jovanović (1986). Influence of a magnetic field on the rate of development of the honeybee preadult stage. *Period. Biol.* **88**, 187-188.
- Prolić, Z., and M. Andjelković (1992). The effect of a strong magnetic field on the frequency of genetic loads in *Drosophila melanogaster*. *Acta Vet.* **42**, 343-350.
- Stanojević, V., Prolić, Z., Savić, T., Todorović, D., and B. Janać (2005). Effects of an extremely low-frequency (50-Hz) magnetic field on development dynamics of the housefly (*Musca domestica* L.). *Electromagn. Biol. Med.* **24**(2), 99-107.

ПРЕЖИВЉАВАЊЕ ЛАРВИ КУЋНЕ СТРИЖИБУБЕ *HYLOTRUPES VAJULUS* ИЗЛОЖЕНИХ КОНСТАНТНОМ МАГНЕТНОМ ПОЉУ ОД 98 мТ У ЛАБОРАТОРИЈСКИМ УСЛОВИМА

СНЕЖАНА РАУШ, ДАЈАНА ТОДОРОВИЋ И З. ПРОЛИЋ

Лабораторија за магнетобиологију и понашање, Институт за биолошка истраживања "Синиша Станковић",
11060 Београд, Србија

Циљ нашег експеримента је био да се утврди како излагање константном магнетном пољу од 98 мТ утиче на понашање у смислу преживљавања и масе ларви кућне стрижибубе (*Hylotrupes bajulus* L.). Показано је да ларве које су се налазиле у магнетном пољу поменутих карактеристика

имају статистички значајно веће преживљавање, као и тенденцију повећања масе у односу на контролну групу јединки. Ови резултати се могу приписати модулаторном утицају спољашњег магнетног поља на метаболизам и неурохуморалну регулацију инсеката.