

Dried Plum as a candidate radiomitigant

Ann-Sofie Schreurs, Candice G.T. Tahimic, Joshua S. Alwood, Ruth K. Globus

NASA Ames Research Center, California, USA



Problem: Spaceflight conditions lead to bone loss



Microgravity

Space conditions

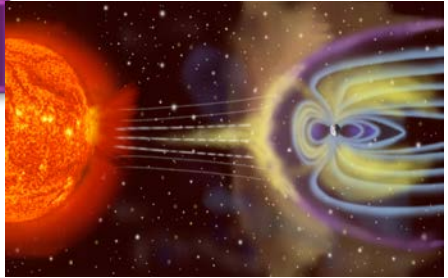
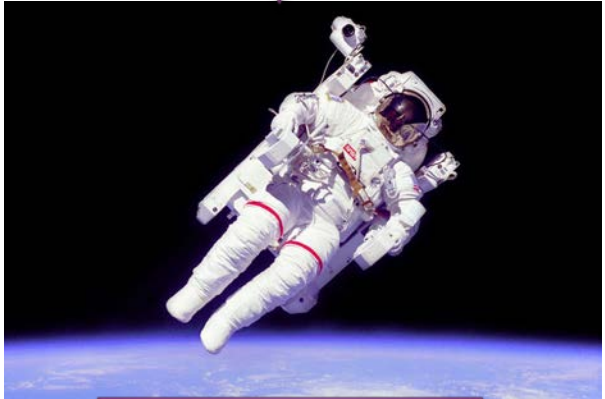

Space Radiation

results

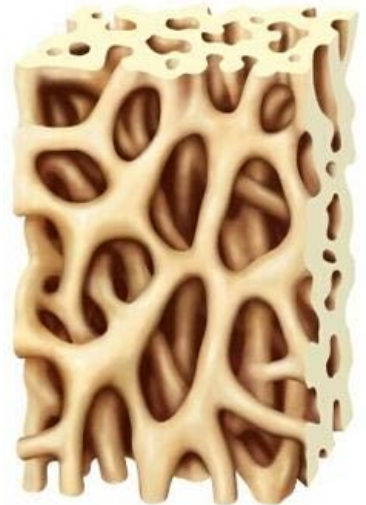

Healthy bone



Osteoporotic bone

Space Radiation

Space radiation sources are:

- Galactic Cosmic Rays (GCR)
- Solar Particle Events (SPE)
- protons and electrons trapped in the Earth's magnetic field

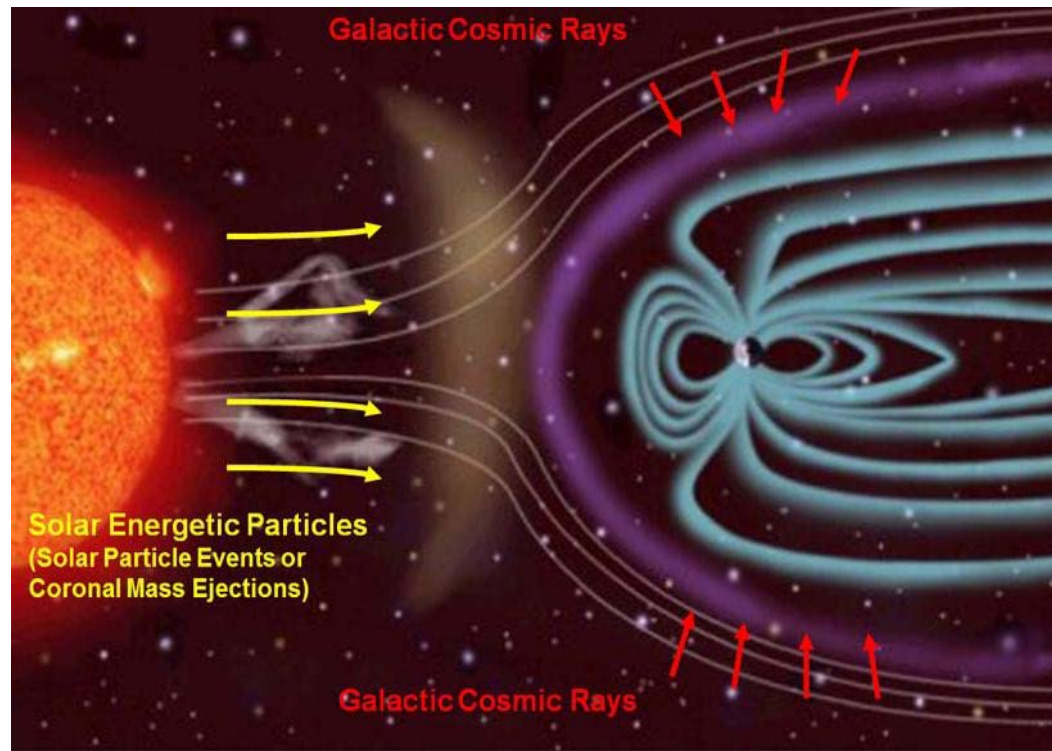

Durante and Cucinotta 2011
Norbury et al. 2016

Space Radiation

Space radiation is composed of a range of ions

- High-Z High Energy Ions (HZE)/ high Linear Energy Transfer (LET)
- low LET e.g. Protons ^1H

low LET \longrightarrow *high LET*

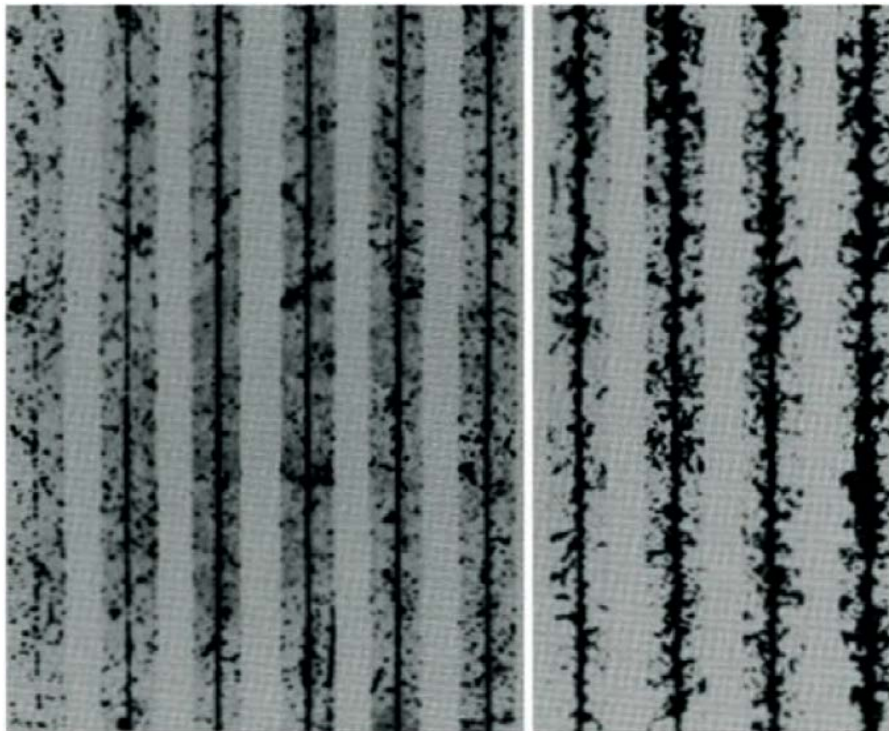

H Z=1 He Z=2 Li Z=3 Be Z=4 B Z=5 C Z=6 Si Z=14 Cs Z=20 Ti Z=22 Fe Z=26

low LET

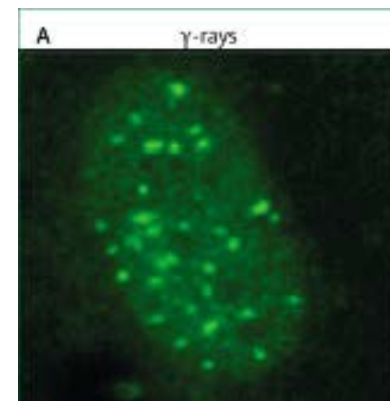

high LET (HZE)

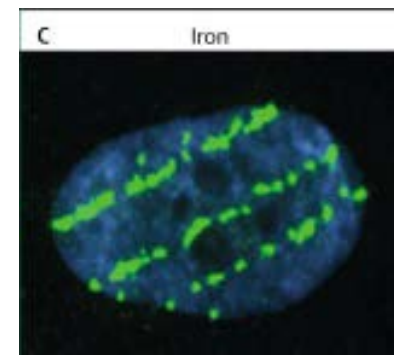

Cucinotta, Durante, 2006
Norbury et al. 2016

Radiation induces cancellous bone loss

^{137}Cs (Gamma) ^1H (Protons); (100-200 cGy)

HZE (^{56}Fe) Iron; (50-100 cGy)

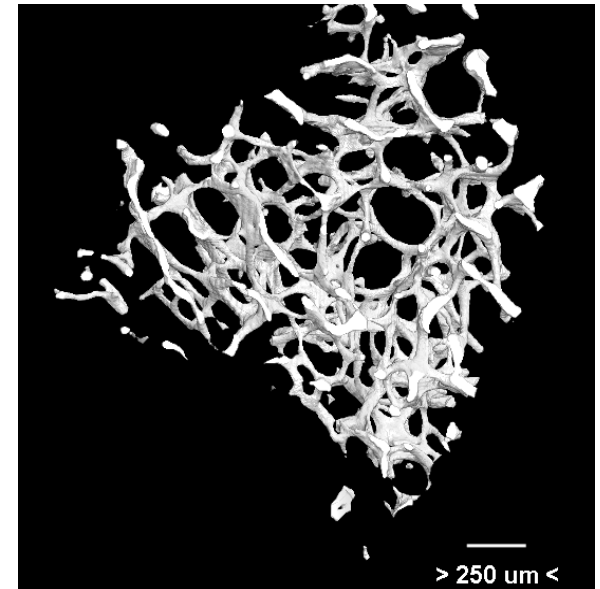
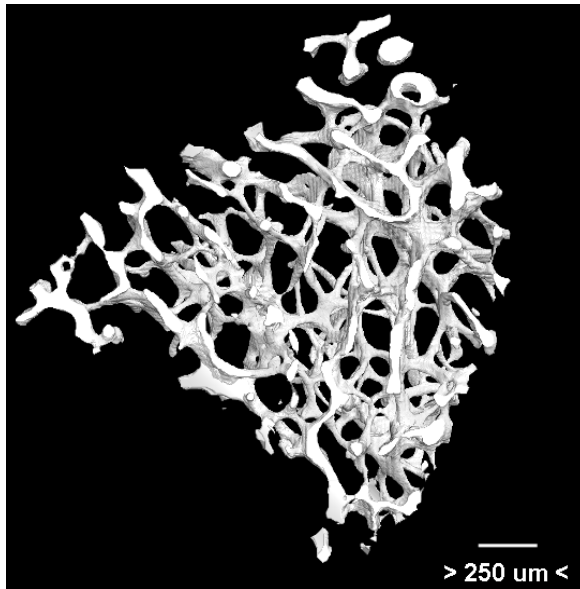

- ↓ Bone Volume/Total Volume
- ↓ Trabecular number

Schreurs et al, 2016

Alwood, Tran, Schreurs et al. 2017

Problem: Spaceflight conditions lead to bone loss



Microgravity

Space conditions

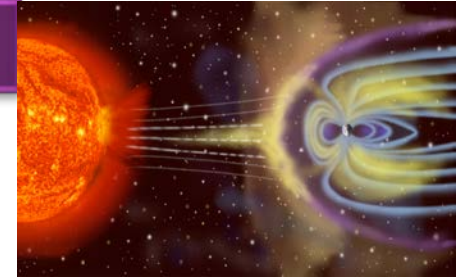

Space Radiation

results

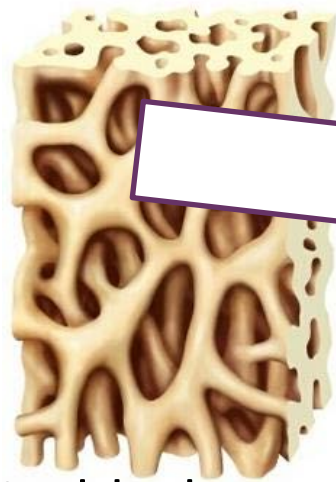

Healthy bone

Preventable??



Osteoporotic bone

Current methods for bone loss prevention

- **Resistive exercises** that mimic mechanical loading (i.e. ARED)



- **Bisphosphonate** prevents BMD decrements (bone mineral density), but has adverse effects. Also only acts on the bone-resorptive osteoclasts.

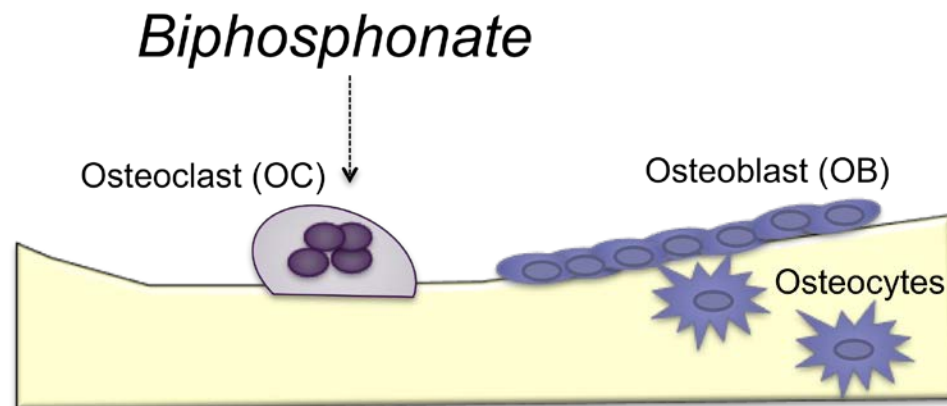

Spaceflight induced bone loss: possible mechanisms of action

Simulated Spaceflight: Hindlimb Unloaded (ug) and Irradiation

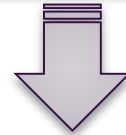

- ↑ bone resorption via osteoclasts
- ↓ bone formation via osteoblasts
- ↑ oxidative stress and damage
- ↑ bone loss

Dried plum diet protects from bone loss caused by ionizing radiation

- Based on hypothesis, selected multiple antioxidants and/or anti-inflammatory diets and drugs
- Diet composed of Dried Plums (DP) was the only effective one
- Prevents radiation-induced increase in markers of osteoclasts (*Rankl*, *Mcp1*), inflammation (*Tnf- α*) and oxidative stress (*Nrf2*)
- Prevents bone loss due to radiation: low LET such as gamma (2Gy, ^{137}Cs), and mix of protons and Iron (1Gy, ^1H ^{56}Fe)

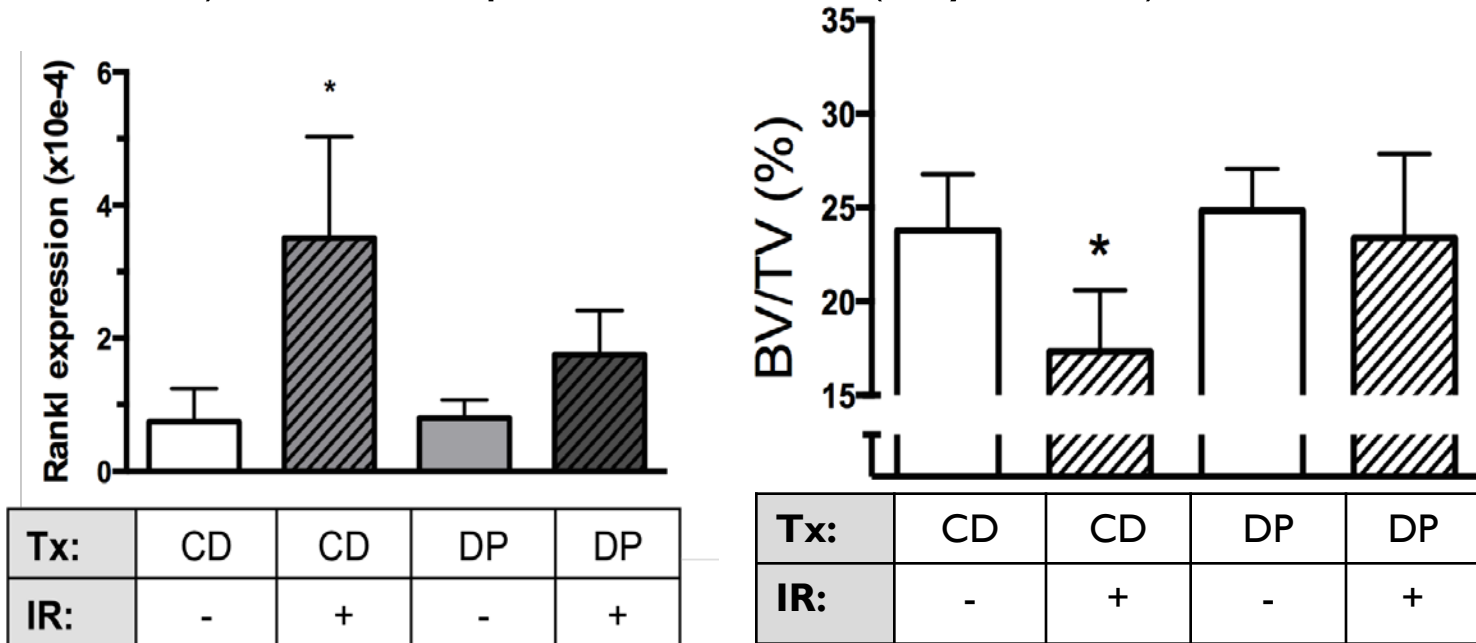

Possible mechanisms of action

simulated spaceflight: HU (ug) and IR

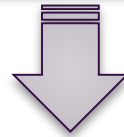

- ↑ bone resorption via osteoclasts
- ↓ bone formation via osteoblasts
- ↑ oxidative stress and damage
- ↑ bone loss (due to IR)

DP acts on

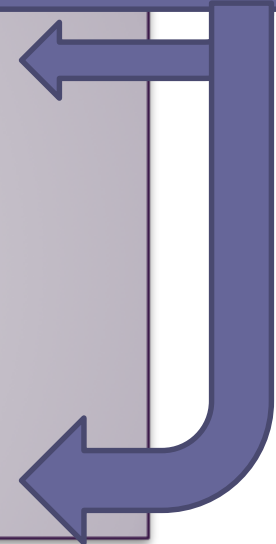

Experiment design

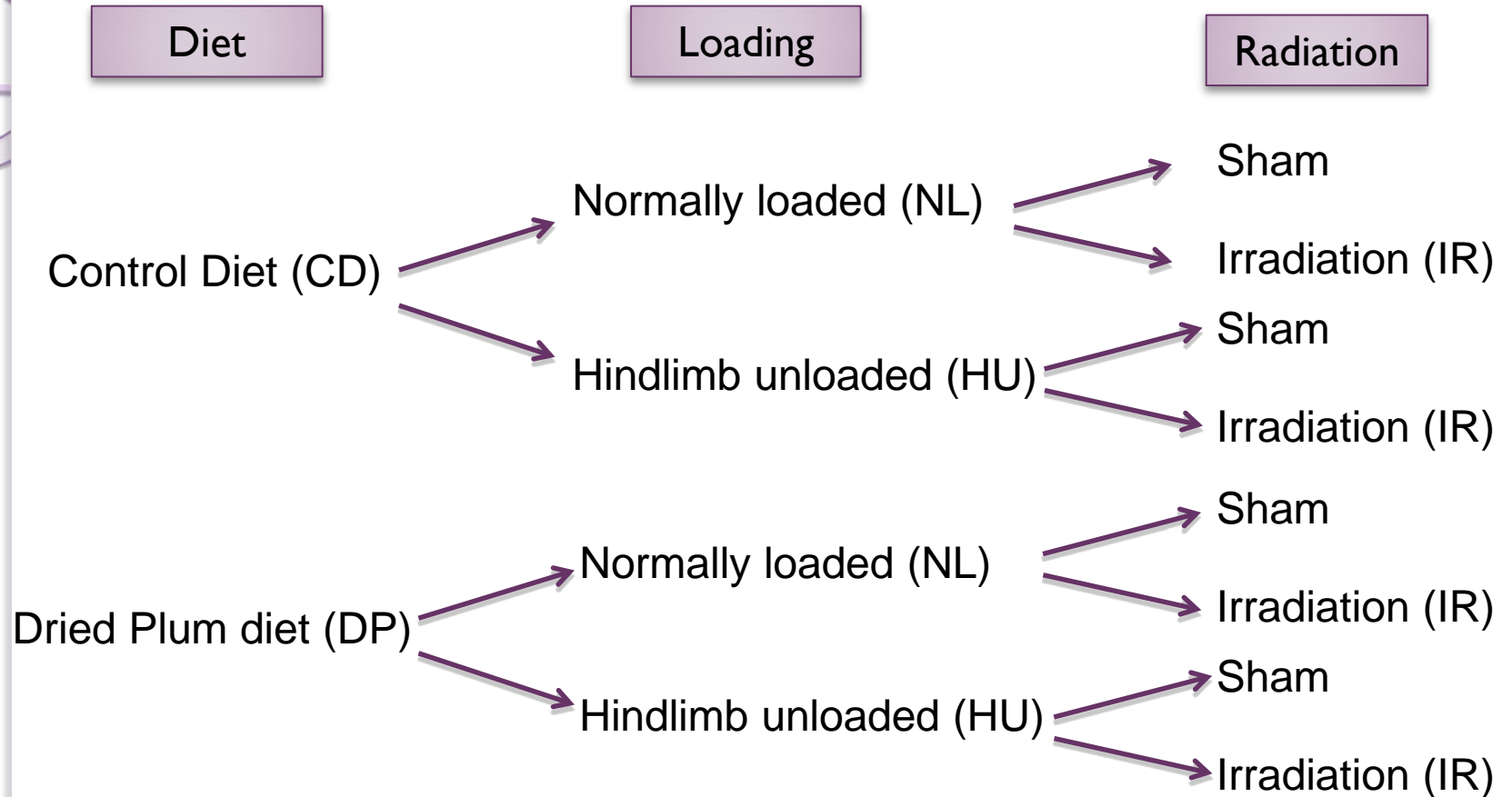

Experiment design

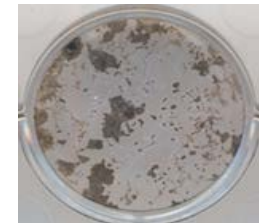
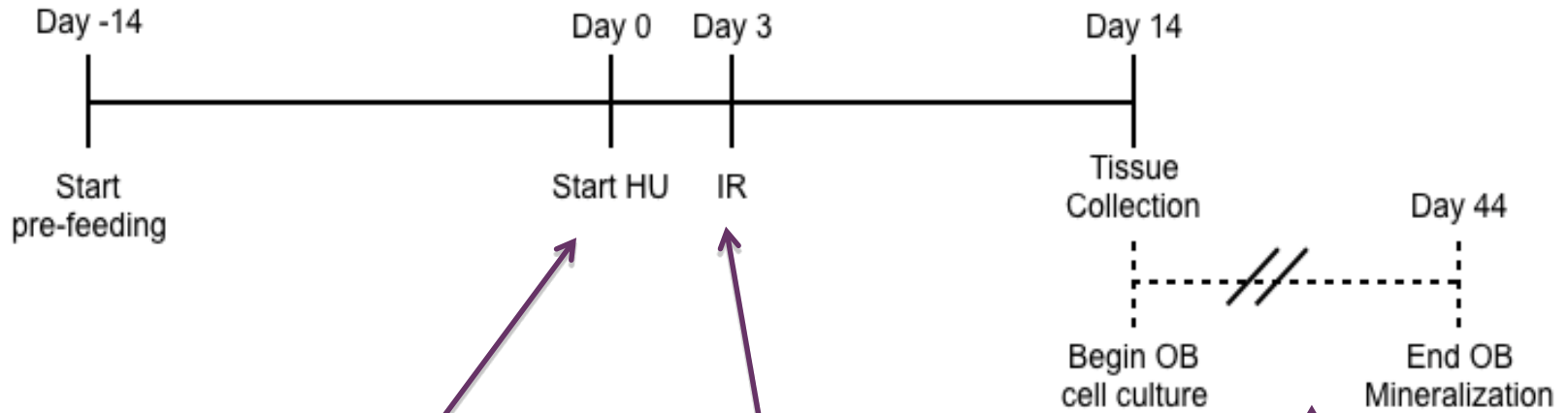

microCT images of the tibia after exposure to simulated weightlessness and ionizing radiation

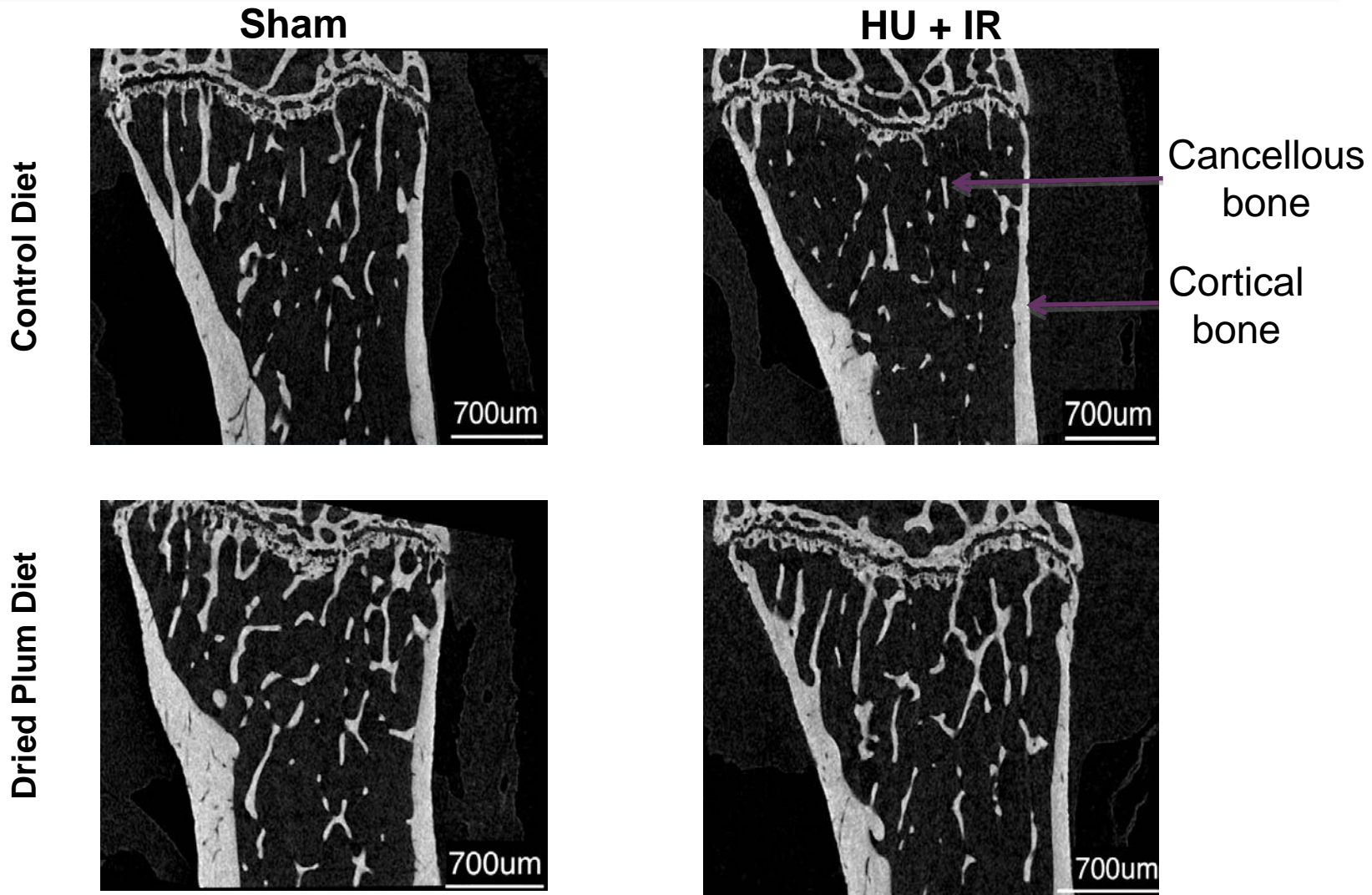

Dried Plum diet prevents cancellous bone loss in long bone (tibia)

Percent Bone Volume

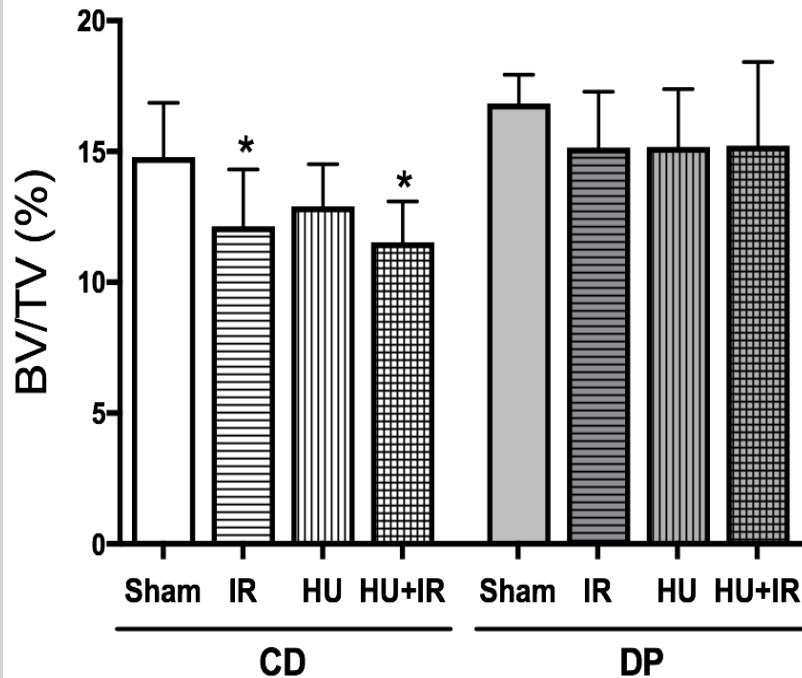

Trabecular Thickness

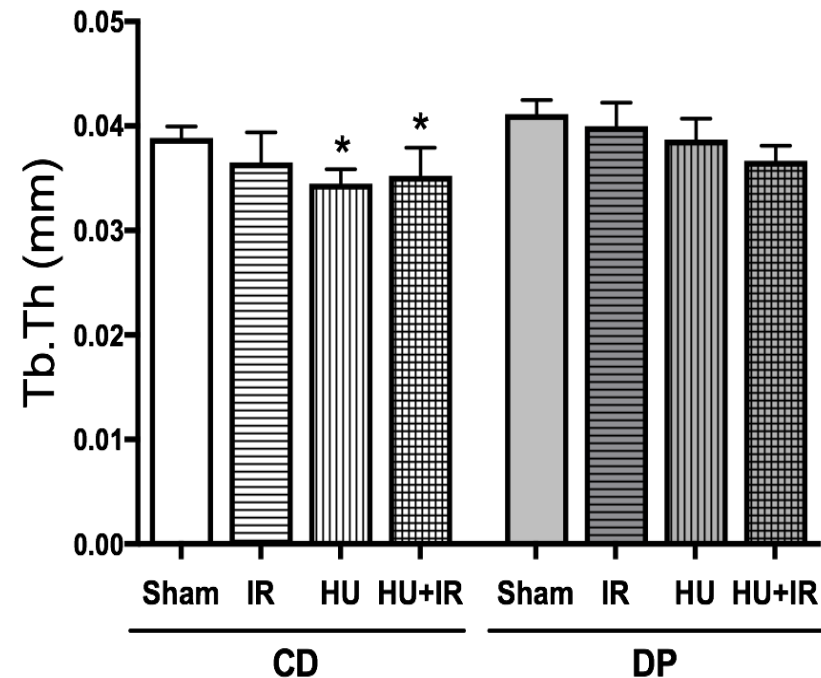

Dried Plum diet prevents cancellous and cortical bone loss in axial bone (vertebrae)

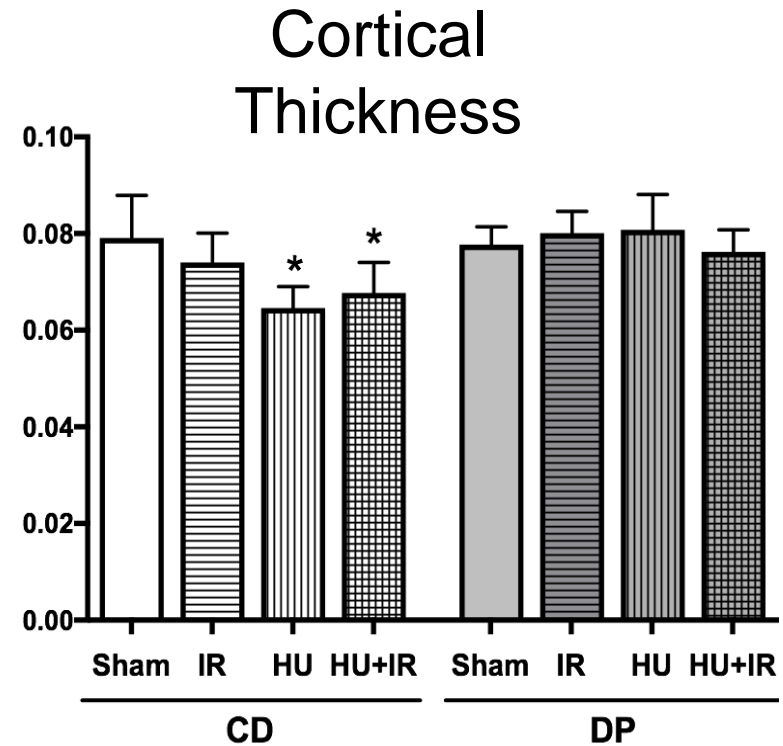
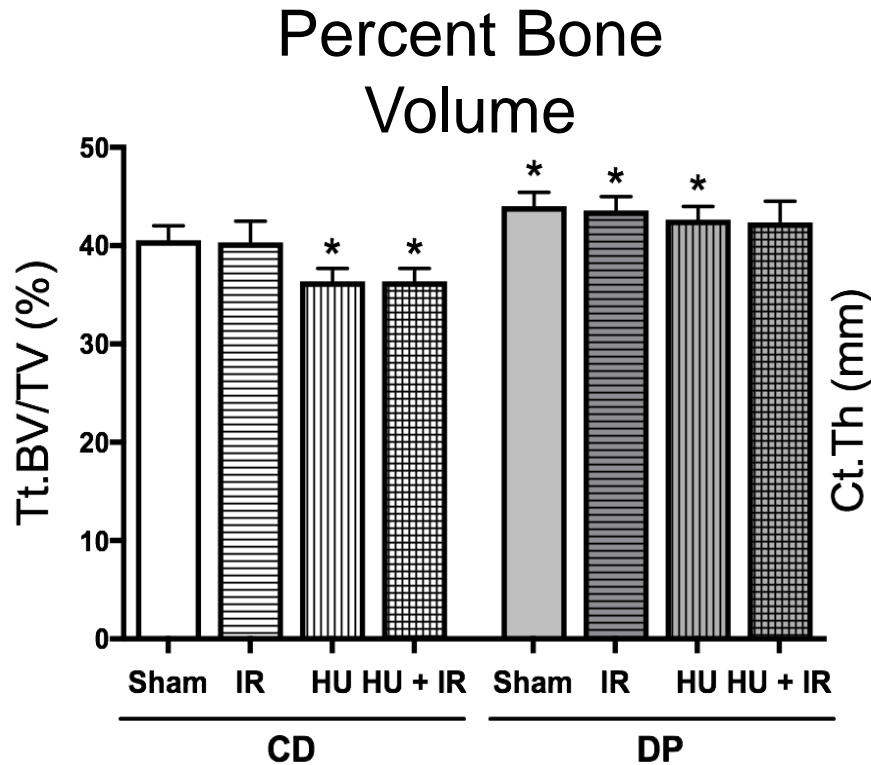

Dried Plum diet prevents bone strength decrease in axial bone (vertebrae)

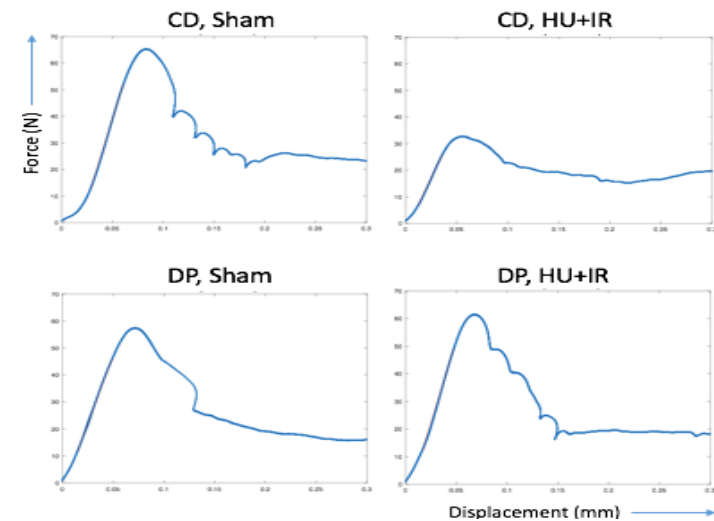
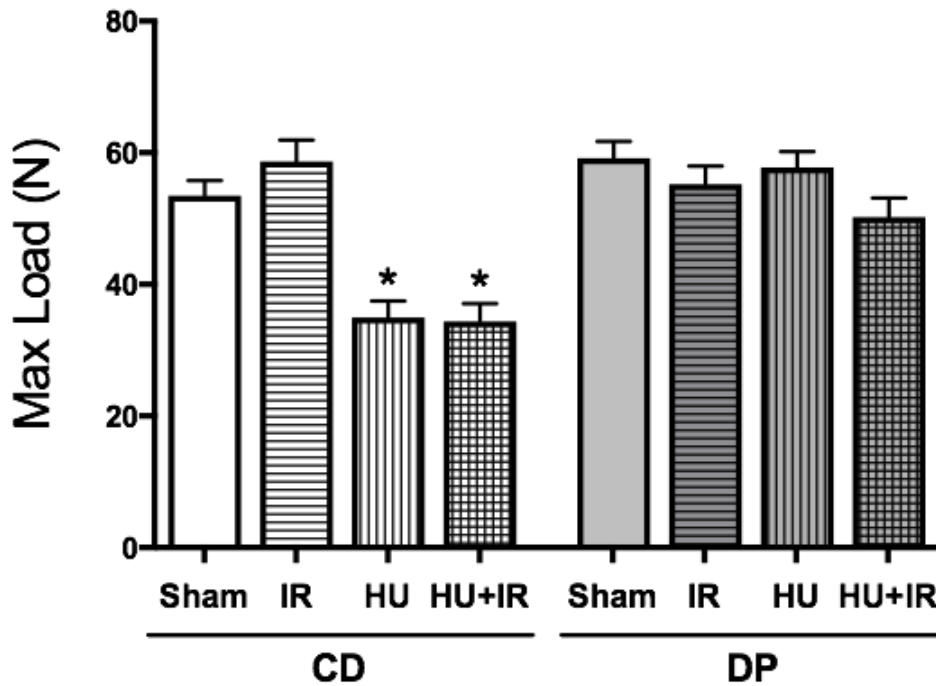

Dried Plum diet protects osteoblast progenitors

OB colony counts/cm²
(day 10)

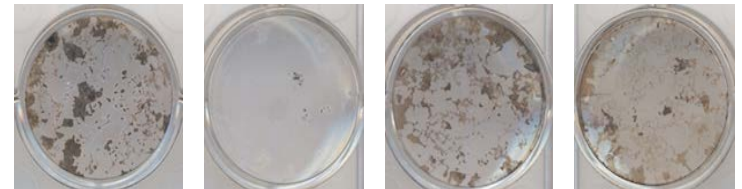
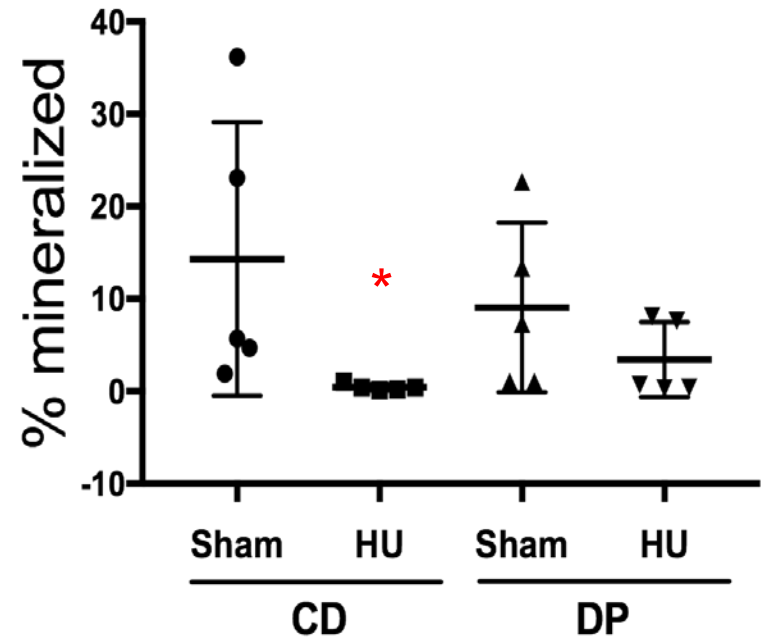
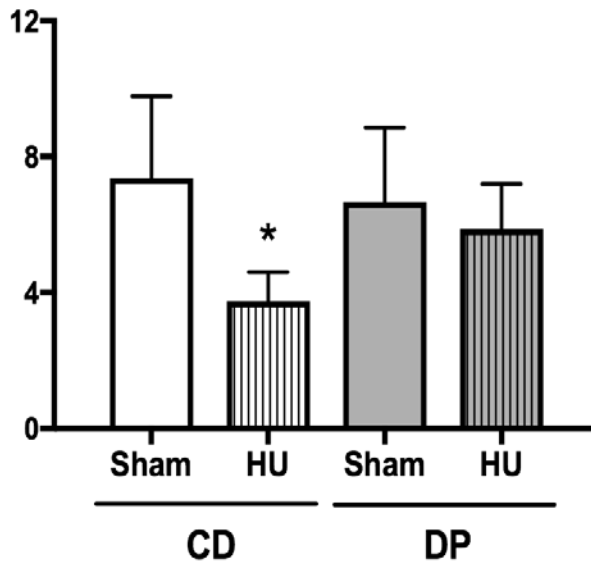

Does DP protect from high dose of HZE particles? Does it protect the osteoprogenitors?

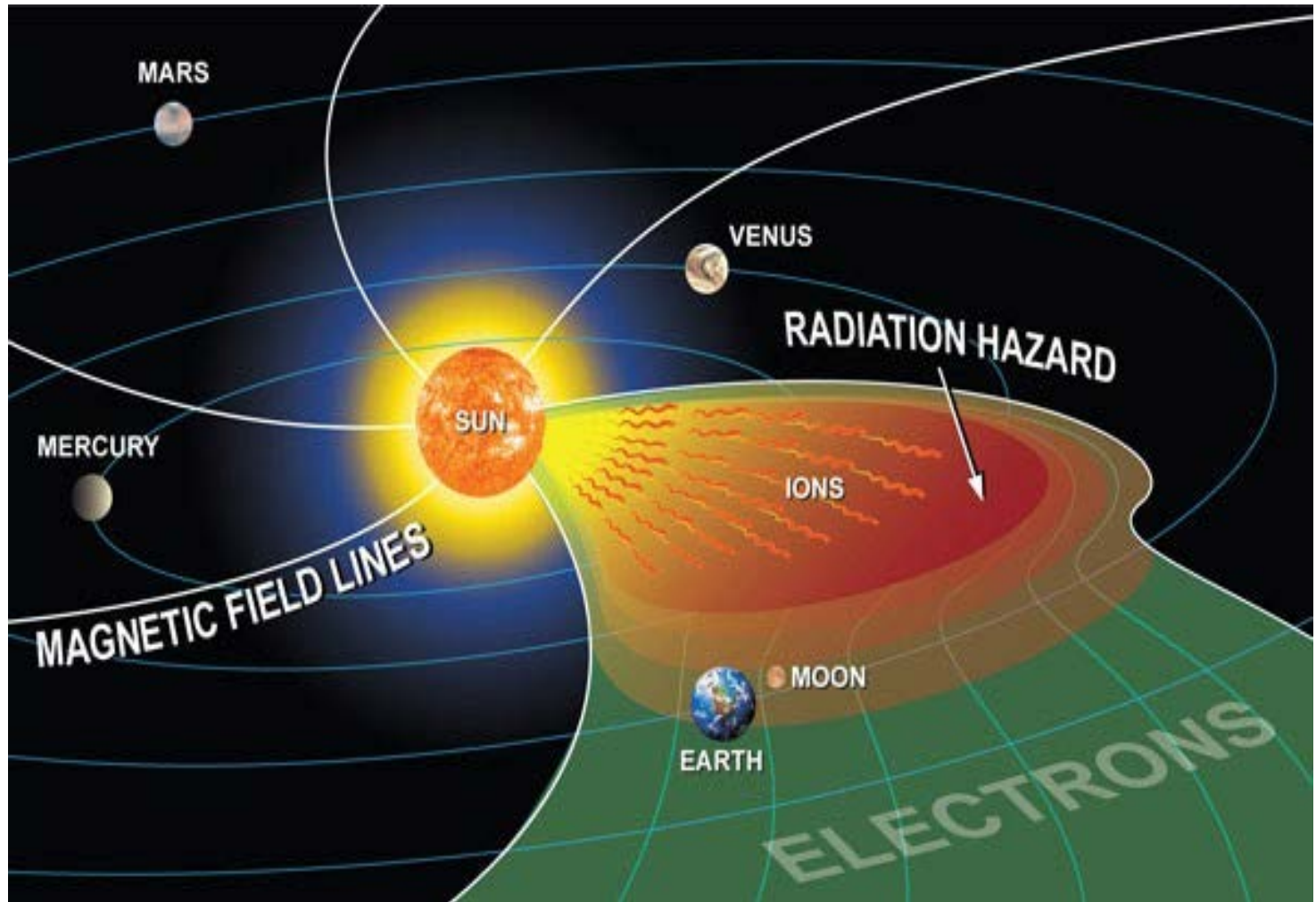

DP prevents from HZE induced cancellous bone loss (1 Gy ⁵⁶Fe)

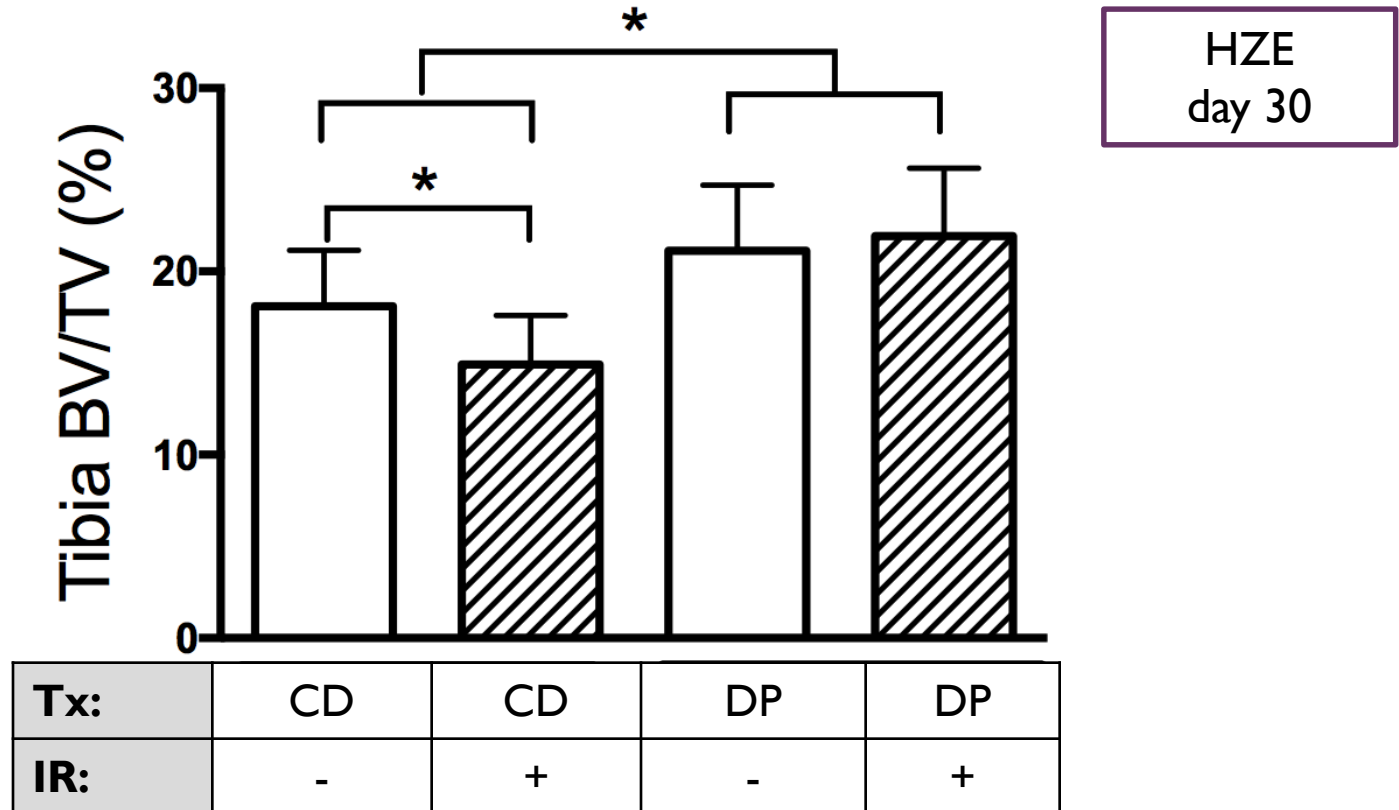

Dried Plum protects marrow-derived osteoblast progenitors in mice exposed to HZE

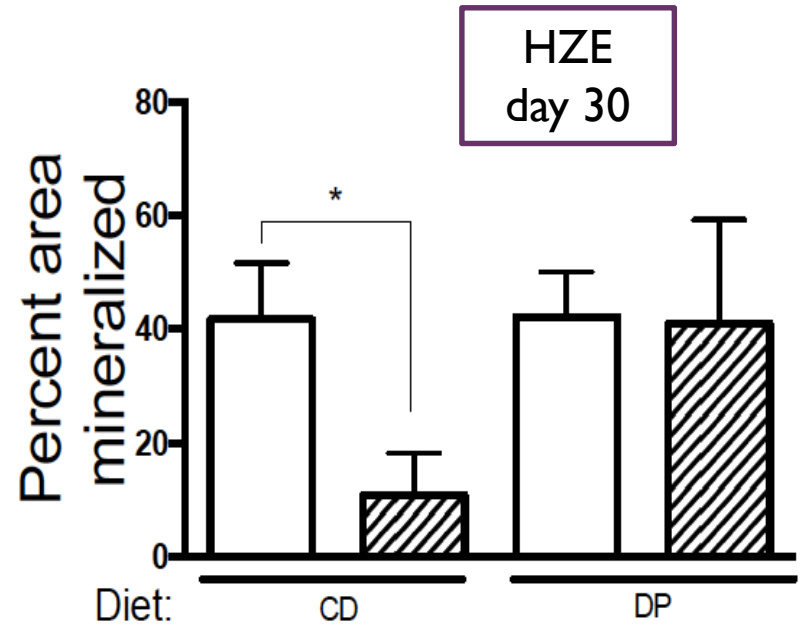
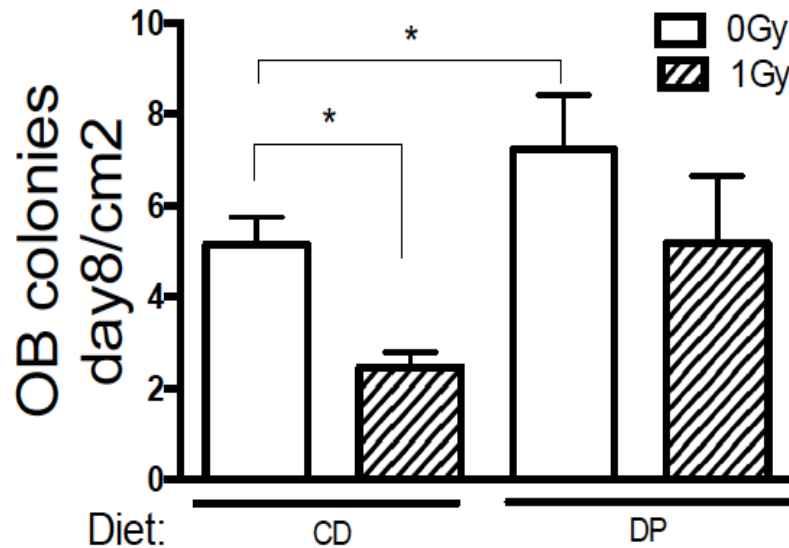

A broader, radiation countermeasure for multiple tissues?

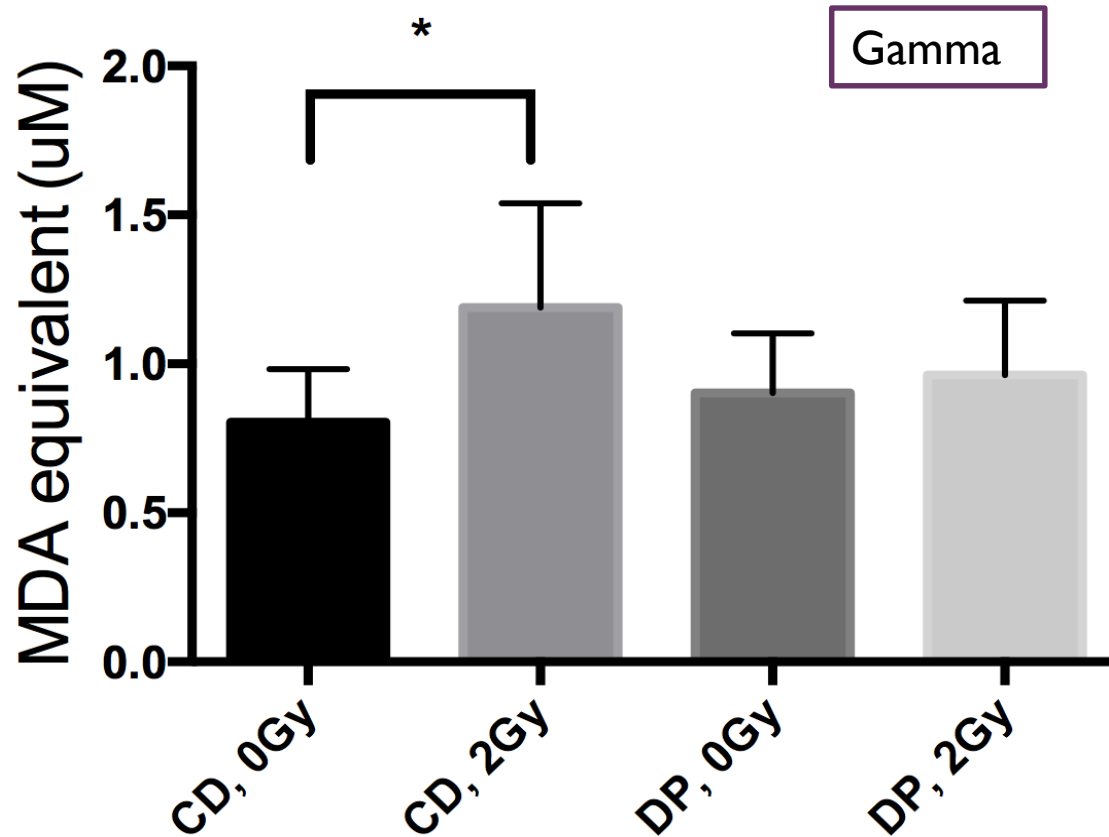

Dietary DP prevents radiation-induced elevation in systemic marker of oxidative stress (serum TBARS)

DP: Possible mechanisms of actions

simulated spaceflight: HU (ug) and IR

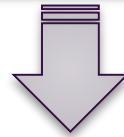

DP acts on

- ↑ bone resorption via osteoclasts
- ↓ bone formation via osteoblasts
- ↑ oxidative stress and damage
- ↑ bone loss (due to HU and IR)

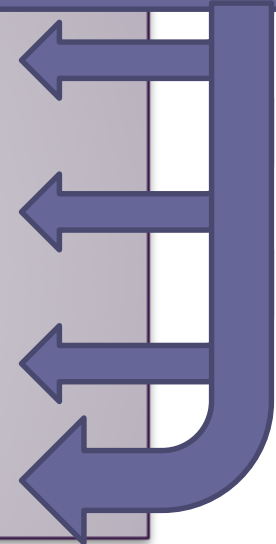

Dried Plum as potential spaceflight countermeasure

★ *DP diet prevents bone decrements due to simulated spaceflight:*

- ***Cancellous and cortical bone loss prevented***
- ***Bone quality and strength***

★ *DP diet fully prevents radiation-induced bone loss from low-LET and high-LET radiation:*

- ***Relevance for both spaceflight and possibly radiotherapy patients***

Dried Plum as potential spaceflight countermeasure

- ★ *DP protects marrow-derived osteoprogenitors:*
 - *possible relevance to mesenchymal stem cells*

- ★ *Mechanisms of DP :*
 - *mitigating early increase in pro-osteoclast cytokines*
 - *protecting the bone-forming osteoblasts*
 - *reduces oxidative stress and inflammation*
 - *A multi-tissue solution?*



Questions that we may be able to address using RNAseq data .

1. What gene networks are responsive to DP?
2. What do these gene networks tell us about the possible mode of action DP?
3. What gene networks are responsive to ionizing radiation exposure? (Regardless of any observed microstructural changes)
4. Does DP prefeeding “prime” bone to defend against IR exposure?



What are the DP-specific responses to radiation?

Unraveling DP diet-induced responses to ionizing radiation

Downregulated genes

CD IR vs CD Sham: 151

DP IR vs DP Sham: 281

Radiation effect:
independent of diet

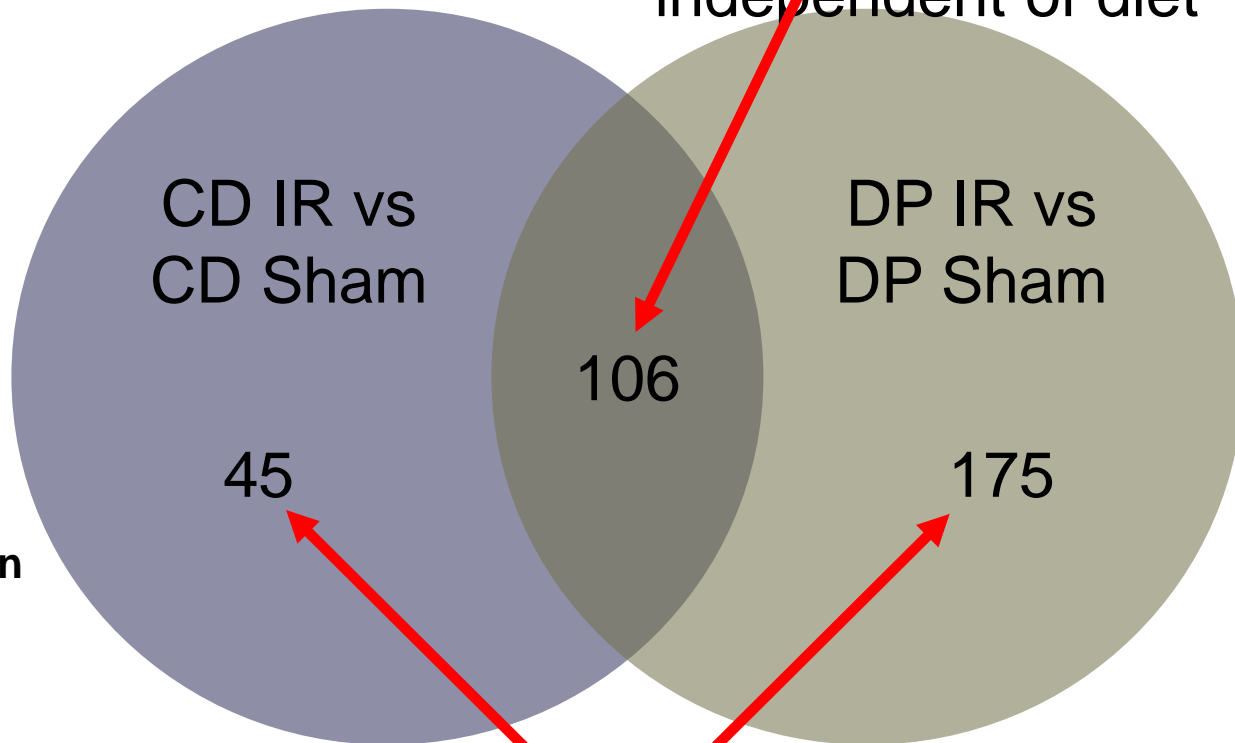

Over representation
analysis using
WEBGESTALT

Cut-off: 1.4 fold change;
Hence, $\text{Fold log } 2 = 0.48$
 $p \leq 0.05$ Benjamini corrected

Compare

DP-specific responses to IR: downregulated gene networks

KEGG Pathways

Description	# of genes	FDR
Hematopoietic cell lineage - Mus musculus (mouse)	10	1.11E-05
Asthma - Mus musculus (mouse)	6	2.21E-05
Platelet activation - Mus musculus (mouse)	10	4.35E-05
Staphylococcus aureus infection - Mus musculus (mouse)	7	6.40E-05
Antigen processing and presentation - Mus musculus (mouse)	8	0.00021852
Intestinal immune network for IgA production - Mus musculus (mouse)	6	0.00021852
Toxoplasmosis - Mus musculus (mouse)	8	0.00076871
Rheumatoid arthritis - Mus musculus (mouse)	7	0.00076871
Leishmaniasis - Mus musculus (mouse)	6	0.00179921
Th17 cell differentiation - Mus musculus (mouse)	7	0.00218071
Tuberculosis - Mus musculus (mouse)	9	0.00218071
Phagosome - Mus musculus (mouse)	9	0.00244633
Systemic lupus erythematosus - Mus musculus (mouse)	8	0.00244633
Th1 and Th2 cell differentiation - Mus musculus (mouse)	6	0.00541676
Cell adhesion molecules (CAMs) - Mus musculus (mouse)	8	0.0061156
Inflammatory bowel disease (IBD) - Mus musculus (mouse)	5	0.0061156
Allograft rejection - Mus musculus (mouse)	5	0.0084218
Graft-versus-host disease - Mus musculus (mouse)	5	0.00854804
Type I diabetes mellitus - Mus musculus (mouse)	5	0.01140061
Autoimmune thyroid disease - Mus musculus (mouse)	5	0.01876814
Influenza A - Mus musculus (mouse)	7	0.02477853
Complement and coagulation cascades - Mus musculus (mouse)	5	0.02624234
Viral myocarditis - Mus musculus (mouse)	5	0.02640207

DP-specific responses to IR: downregulated gene networks

Reactome Pathways

Description	# of genes	FDR
Hemostasis	24	3.02E-08
Platelet activation, signaling and aggregation	14	9.87E-05
Platelet degranulation	9	0.00140932
Response to elevated platelet cytosolic Ca ²⁺	9	0.00143111
Immune System	32	0.00372541
Common Pathway of Fibrin Clot Formation	4	0.01420829
Platelet homeostasis	5	0.02983486
Neutrophil degranulation	14	0.03487056
Innate Immune System	23	0.03487056

Rheumatoid arthritis-related genes are downregulated in bones of DP-fed animals exposed to IR

RHEUMATOID ARTHRITIS

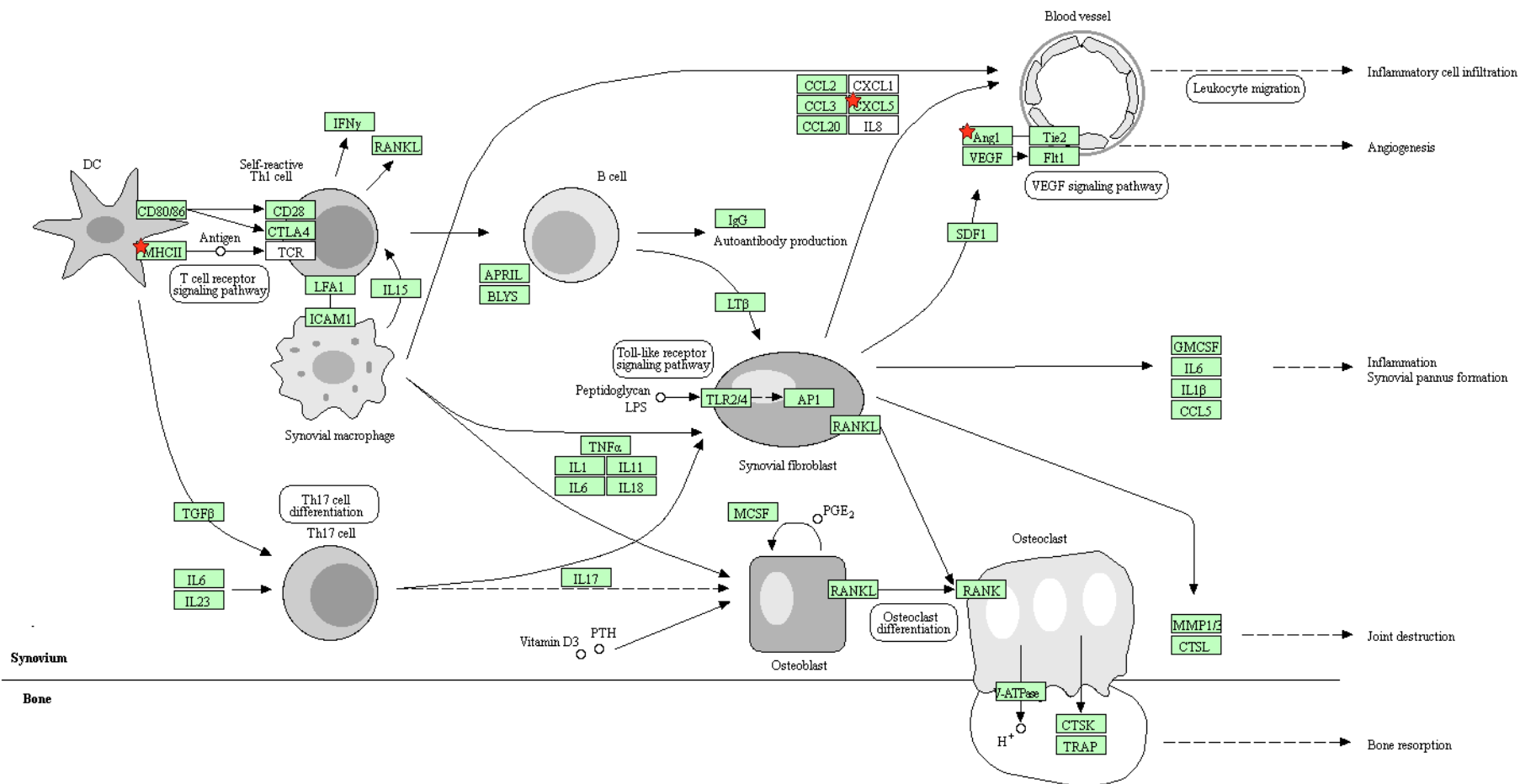

Genes associated with phagosome formation and lysosomal fusion are downregulated in bones of DP-fed animals exposed to IR

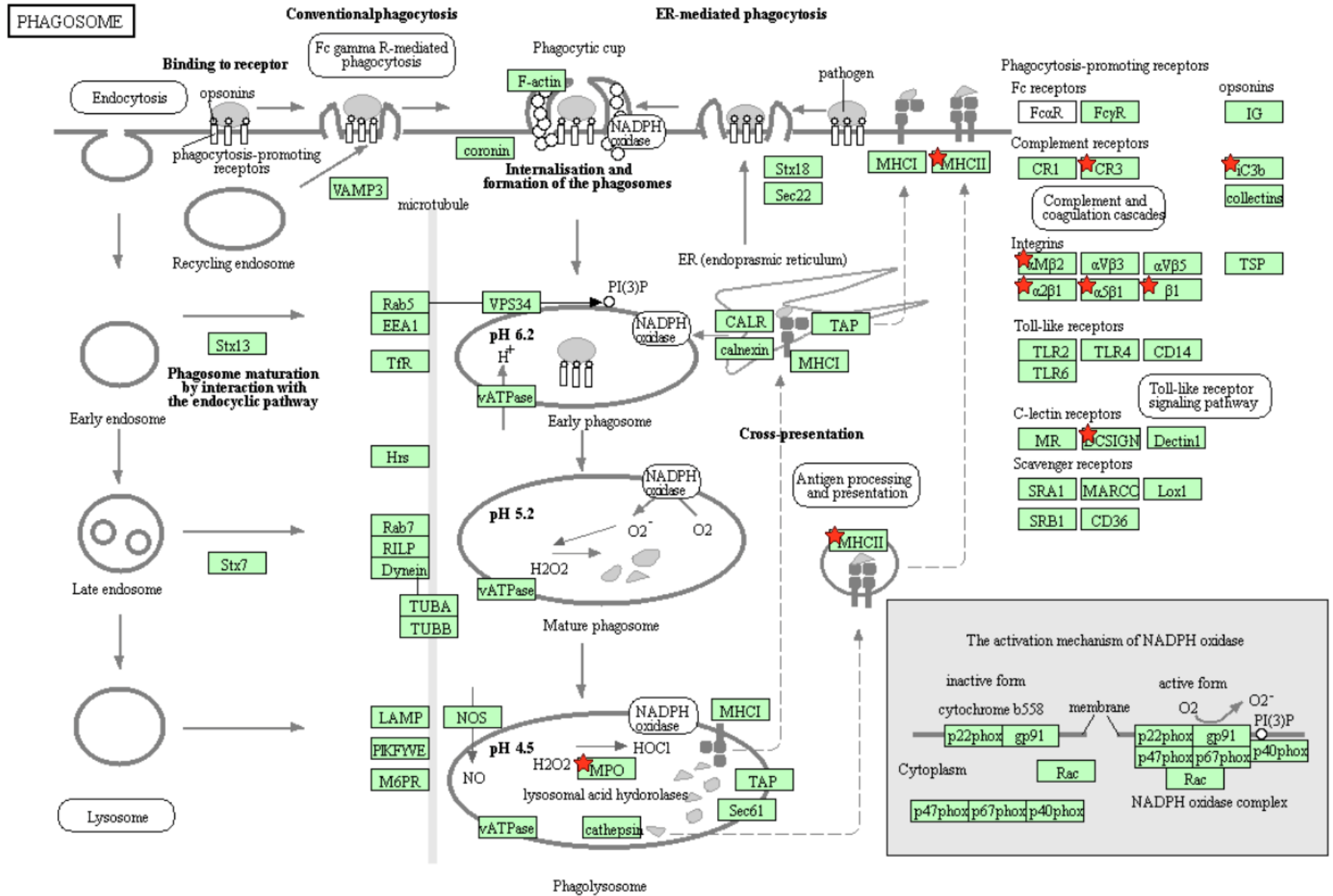

Cell adhesion genes are downregulated in bones of DP-fed animals exposed to IR

CELL ADHESION MOLECULES

IMMUNE SYSTEM

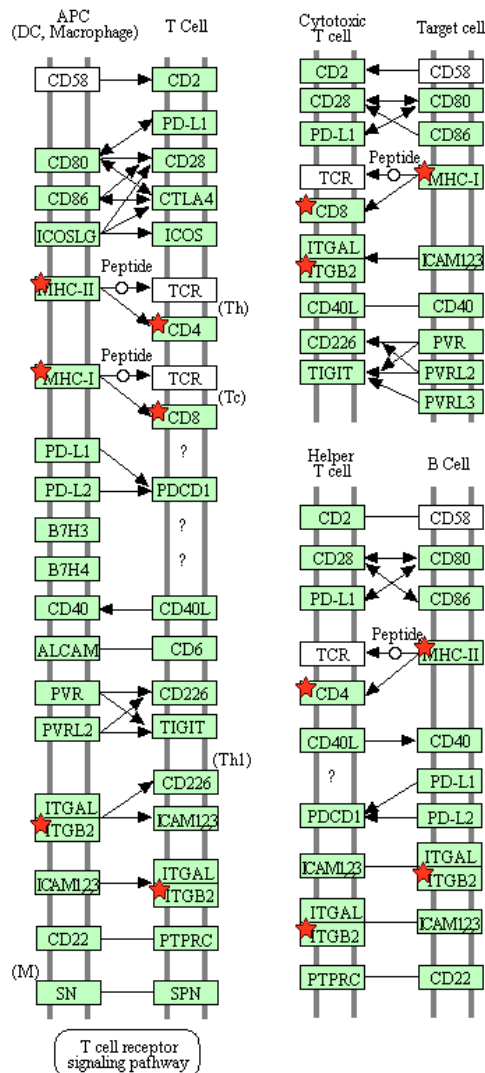

Endothelial cells

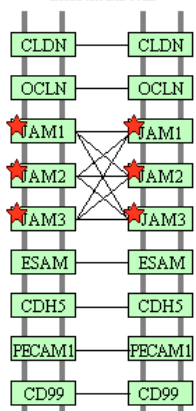

Tight junction
Leukocyte transendothelial migration

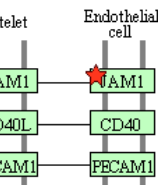
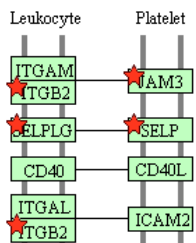

Complement and coagulation cascade

Leukocyte Endothelial cell

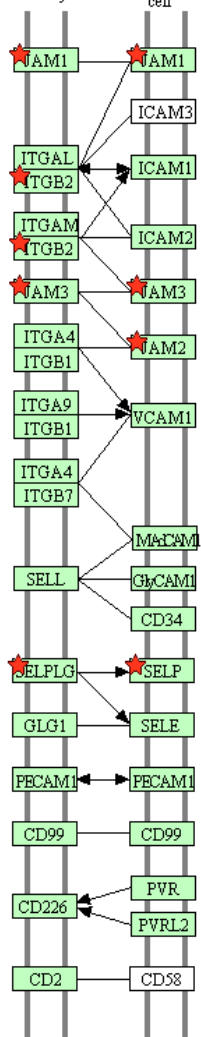

Leukocyte transendothelial migration

NEURAL SYSTEM

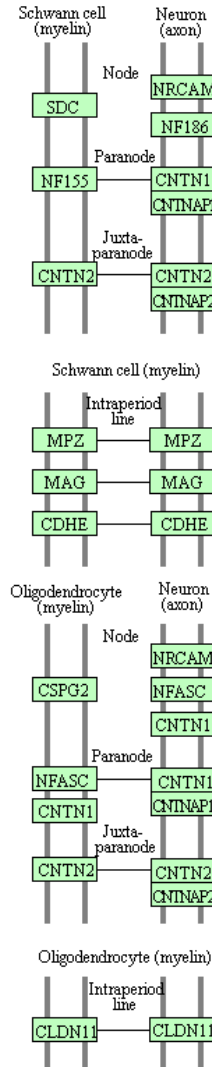
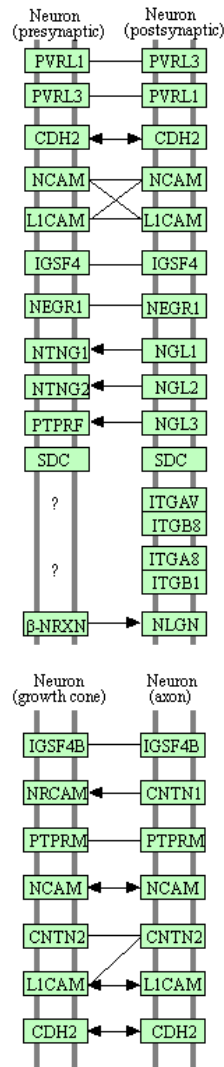

OTHER SYSTEMS

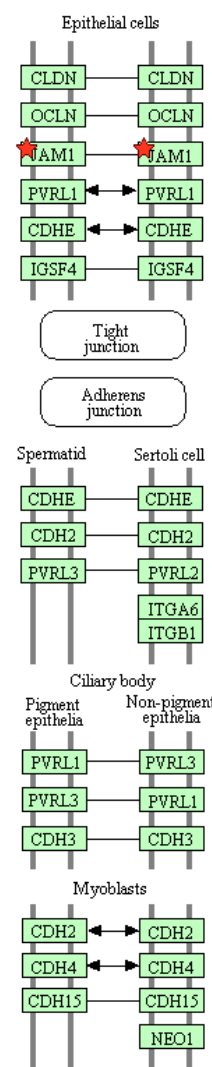

Unraveling DP diet-induced responses to ionizing radiation

Upregulated genes

CD IR vs CD Sham: 142

DP IR vs DP Sham: 111

Radiation effect:
independent of diet

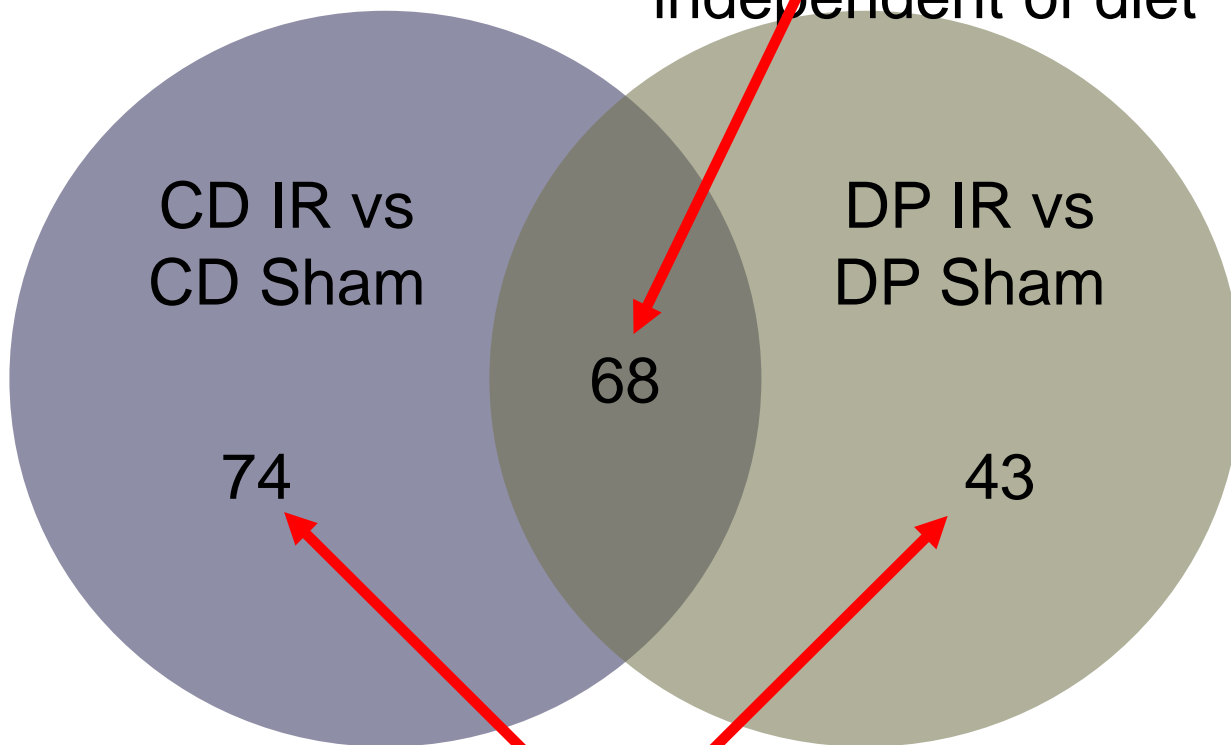

Over representation
analysis using
WEBGESTALT

Cut-off: 1.4 fold change;
Hence, Fold log 2 = 0.48
 $p \leq 0.05$ Benjamini corrected

Compare

Upregulated genes in response to IR in CD group (all genes)

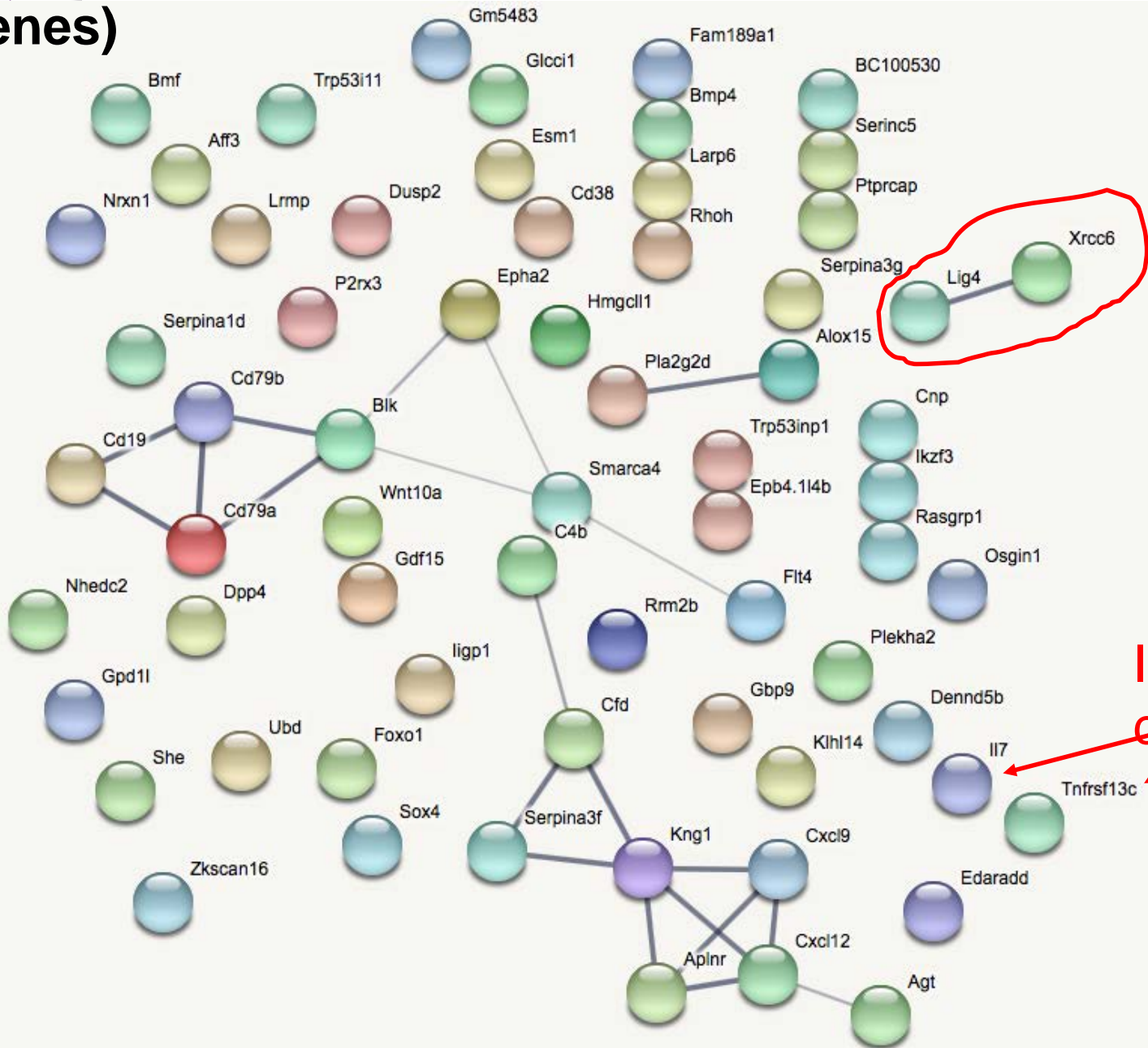

DNA
damage
response

Inflammatory
cytokines

Upregulated genes in response to IR in DP group (all genes)

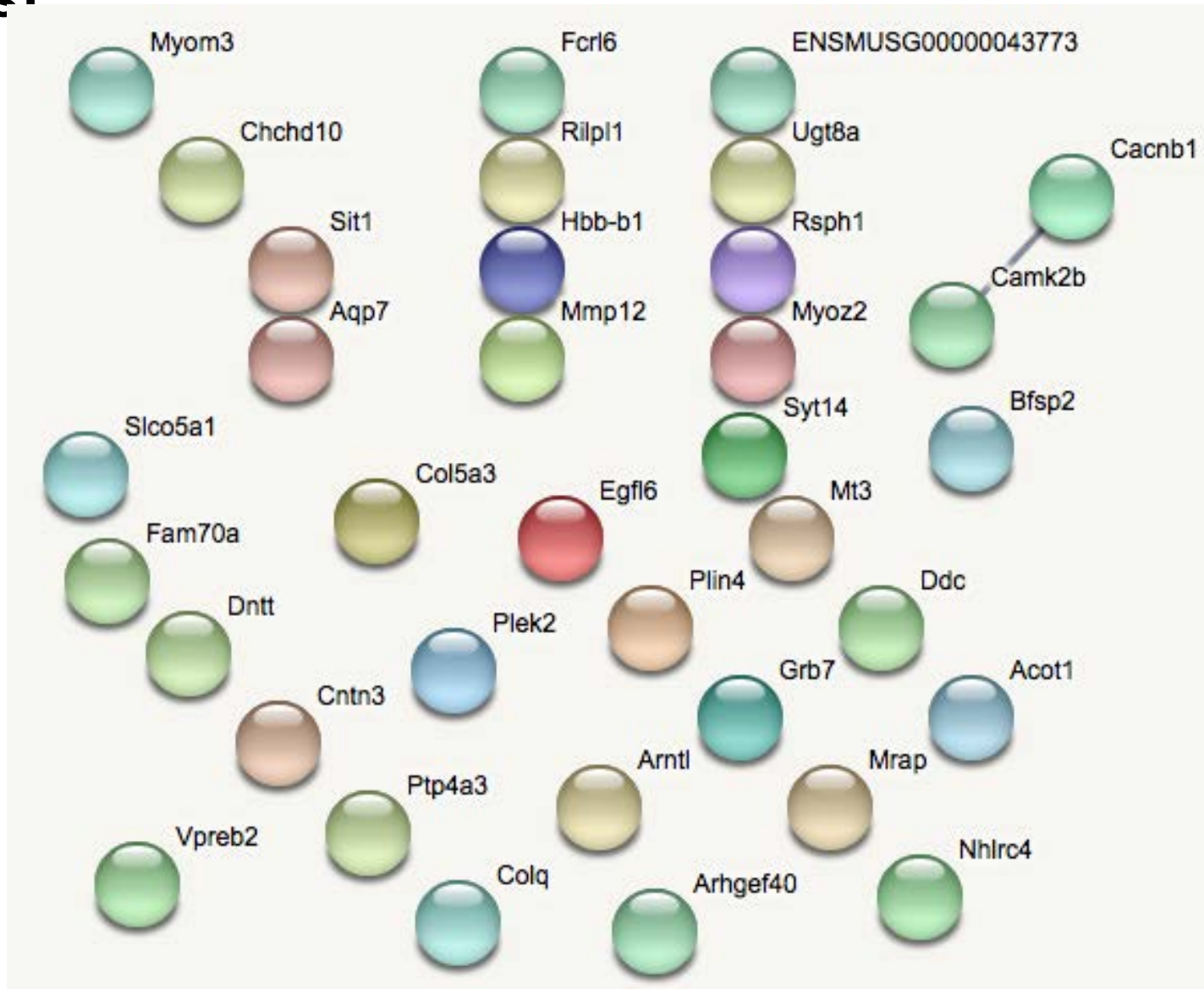

Downregulated genes in response to IR in CD group (all genes)

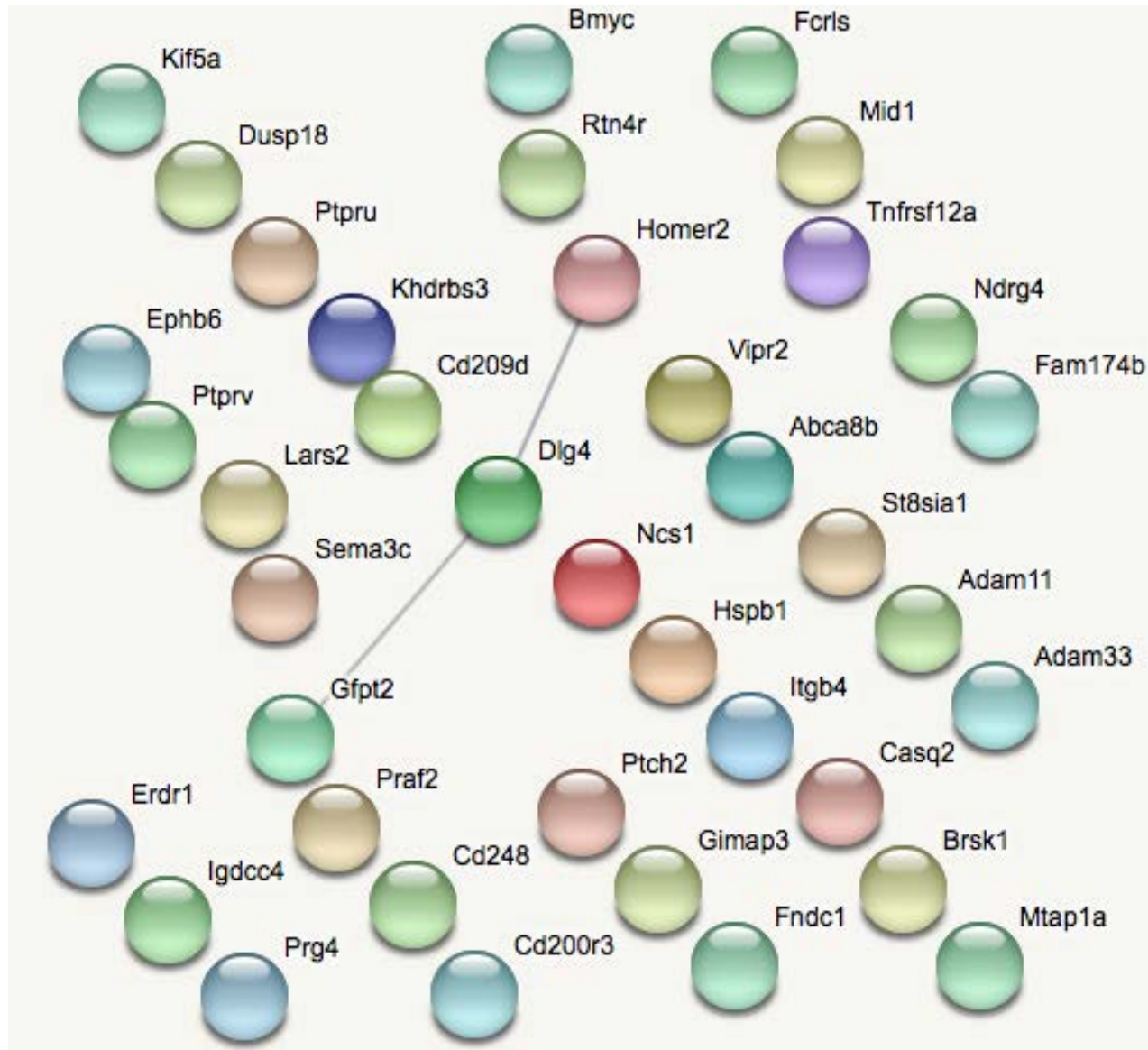

Downregulated genes in response to IR in DP group (all gene

gene

Inflammatory cytokine

Adhesion molecule

Inflammatory cytokine

Myeloperoxidase

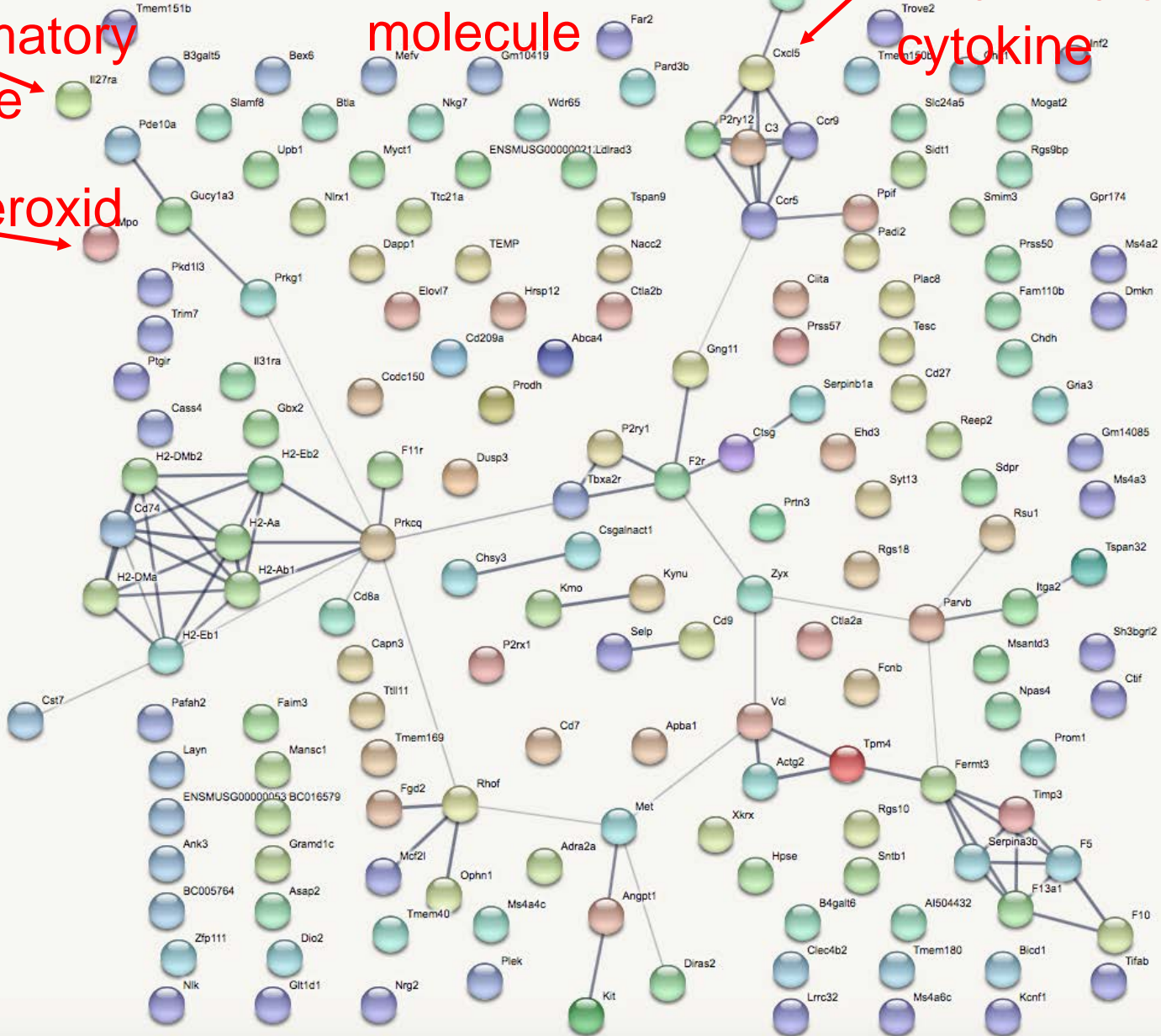

Drugs that act on genes downregulated by IR in DP-treated mice (Top 20)

17: Drug [Display Chart] 157 input genes in category / 20813 annotations before applied cutoff / 22841 genes in category

ID	Name	Source	pValue	FDR B&H	FDR B&Y	Bonferroni	Genes from Input	Genes in Annotation
1	CID009548826 T x A	Stitch	1.245E-9	2.590E-5	2.725E-4	2.590E-5	8	48
2	ctd:D002737 Chloroprene	CTD	2.793E-9	2.907E-5	3.058E-4	5.814E-5	31	1355
3	CID009854011 cangrelor	Stitch	2.517E-8	1.536E-4	1.616E-3	5.239E-4	6	27
4	CID000000899 N-acetylhexosamine	Stitch	2.953E-8	1.536E-4	1.616E-3	6.145E-4	17	472
5	CID000114873 thromboxane	Stitch	4.895E-8	1.925E-4	2.025E-3	1.019E-3	12	223
6	ctd:C022921 benzo(k)fluoranthene	CTD	5.638E-8	1.925E-4	2.025E-3	1.173E-3	19	620
7	CID000000191 arabinosyladenine	Stitch	6.507E-8	1.925E-4	2.025E-3	1.354E-3	21	762
8	ctd:C473384 lumiracoxib Cox-2 inhibitor NSAID	CTD	7.399E-8	1.925E-4	2.025E-3	1.540E-3	4	7
9	ctd:D016264 Dextran Sulfate	CTD	8.601E-8	1.989E-4	2.092E-3	1.790E-3	11	190
10	CID000005461 TXB2 (thromboxane B2)	Stitch	1.284E-7	2.673E-4	2.812E-3	2.673E-3	9	118
11	CID006918456 prasugrel	Stitch	2.026E-7	3.833E-4	4.032E-3	4.216E-3	7	61
12	CID000121963 L-658,758	Stitch	2.635E-7	4.219E-4	4.439E-3	5.485E-3	4	9
13	ctd:C074619 bivalirudin	CTD	2.635E-7	4.219E-4	4.439E-3	5.485E-3	4	9
14	CID000160247 naphthol AS-D chloroacetate	Stitch	5.830E-7	8.667E-4	9.118E-3	1.213E-2	7	71
15	CID000002232 1dwc	Stitch	6.254E-7	8.678E-4	9.130E-3	1.302E-2	6	45
16	CID000004792 phorbol acetate myristate	Stitch	1.036E-6	1.185E-3	1.247E-2	2.157E-2	27	1400
17	CID000002499 enantio-PAF-C16	Stitch	1.048E-6	1.185E-3	1.247E-2	2.182E-2	11	244
18	2295 UP Riluzole hydrochloride; Up 200; 14.8uM; MCF7; HT HG-U133A	Broad Institute CMAP Up	1.080E-6	1.185E-3	1.247E-2	2.248E-2	10	196
19	ctd:D004054 Diethylstilbestrol	CTD	1.082E-6	1.185E-3	1.247E-2	2.252E-2	26	1316
20	CID009543487 C4 m	Stitch	1.214E-6	1.234E-3	1.299E-2	2.526E-2	7	79

Drugs that act on genes upregulated by IR in DP-treated mice (Top 20)

Dietary supplement and drug given to patients with AD and senile dementia; increases lifespan of mice

17: Drug [Display Chart] 33 input genes in category / 6202 annotations before applied cutoff / 22841 genes in category

ID	Name	Source	pValue	FDR B&H	FDR B&Y	Bonferroni	Genes from Input	Genes in Annotation
1	CID000171612 baciphelacin	Stitch	3.095E-6	1.372E-2	1.277E-1	1.919E-2	4	70
2	CID000157386 D-FMAUTP	Stitch	6.067E-6	1.372E-2	1.277E-1	3.763E-2	2	3
3	4268 UP Meclofenoxate hydrochloride [3685-84-5]; Up 200; 13.6uM; PC3; HT HG-U133A	Broad Institute CMAP Up	7.809E-6	1.372E-2	1.277E-1	4.843E-2	5	192
4	2490 UP Nifuroxazide [965-52-6]; Up 200; 14.6uM; HL60; HT HG-U133A	Broad Institute CMAP Up	8.847E-6	1.372E-2	1.277E-1	5.487E-2	5	197
5	ctd:C016517 indole-3-carbinol	CTD	2.507E-5	3.109E-2	2.895E-1	1.555E-1	9	1145
6	CID000503022 L-OddCTP	Stitch	4.232E-5	4.374E-2	4.072E-1	2.624E-1	2	7
7	ctd:C501413 tesaglitazar	CTD	7.478E-5	4.631E-2	4.311E-1	4.638E-1	6	504
8	CID000490401 FIAUTP	Stitch	9.043E-5	4.631E-2	4.311E-1	5.609E-1	2	10
9	ctd:C041786 palm oil	CTD	1.177E-4	4.631E-2	4.311E-1	7.298E-1	10	1742
10	4085 UP Thioridazine hydrochloride [130-61-0]; Up 200; 9.8uM; PC3; HT HG-U133A	Broad Institute CMAP Up	1.250E-4	4.631E-2	4.311E-1	7.750E-1	4	179
11	CID000008095 EGEEA	Stitch	1.324E-4	4.631E-2	4.311E-1	8.211E-1	2	12
12	4070 UP Methionine sulfoximine (L) [15985-39-4]; Up 200; 22.2uM; PC3; HT HG-U133A	Broad Institute CMAP Up	1.736E-4	4.631E-2	4.311E-1	1.000E0	4	195
13	3706 UP Demeclocycline hydrochloride [64-73-3]; Up 200; 8uM; PC3; HT HG-U133A	Broad Institute CMAP Up	1.771E-4	4.631E-2	4.311E-1	1.000E0	4	196
14	4089 UP Amyleine hydrochloride [532-59-2]; Up 200; 14.8uM; PC3; HT HG-U133A	Broad Institute CMAP Up	1.771E-4	4.631E-2	4.311E-1	1.000E0	4	196
15	5736 UP Trioxsalen [3902-71-4]; Up 200; 17.6uM; PC3; HT HG-U133A	Broad Institute CMAP Up	1.771E-4	4.631E-2	4.311E-1	1.000E0	4	196
16	5949 UP AG-013608 [351320-38-2]; Up 200; 10uM; PC3; HT HG-U133A	Broad Institute CMAP Up	1.806E-4	4.631E-2	4.311E-1	1.000E0	4	197
17	337 UP felodipine; Up 200; 10uM; MCF7; HG-U133A	Broad Institute CMAP Up	1.806E-4	4.631E-2	4.311E-1	1.000E0	4	197
18	2129 UP Retrorsine [480-54-6]; Up 200; 11.4uM; HL60; HT HG-U133A	Broad Institute CMAP Up	1.806E-4	4.631E-2	4.311E-1	1.000E0	4	197
19	3088 DN Idazoxan hydrochloride [79944-56-2]; Down 200; 16.6uM; HL60; HT HG-U133A	Broad Institute CMAP Down	1.841E-4	4.631E-2	4.311E-1	1.000E0	4	198
20	2458 DN Cefotiam hydrochloride; Down 200; 7.2uM; HL60; HT HG-U133A	Broad Institute CMAP Down	1.841E-4	4.631E-2	4.311E-1	1.000E0	4	198

Drugs that act on genes upregulated by IR in CD-treated mice (Top 20)

17: Drug [Display Chart] 63 input genes in category / 13457 annotations before applied cutoff / 22841 genes in category

ID	Name	Source	pValue	FDR B&H	FDR B&Y	Bonferroni	Genes from Input	Genes in Annotation
1	ctd:D002737 Chloroprene	CTD	4.806E-13	6.468E-9	6.522E-8	6.468E-9	23	1355
2	ctd:C017096 n-butoxyethanol	CTD	5.519E-10	3.714E-6	3.745E-5	7.428E-6	14	587
3	CID000005292 AC1L1K12	Stitch	1.296E-8	5.812E-5	5.861E-4	1.744E-4	7	102
4	ctd:D004317 Doxorubicin (Chemotherapy drug)	CTD	3.324E-8	1.118E-4	1.128E-3	4.474E-4	20	1785
5	CID000022641 U-2112	Stitch	3.036E-7	7.885E-4	7.952E-3	4.085E-3	4	21
6	ctd:C008261 lead acetate	CTD	3.516E-7	7.885E-4	7.952E-3	4.731E-3	19	1862
7	ctd:D003520 Cyclophosphamide	CTD	8.802E-7	1.692E-3	1.706E-2	1.185E-2	11	617
8	CID003081759 DD-PCR	Stitch	2.020E-6	3.398E-3	3.427E-2	2.718E-2	5	75
9	CID000426387 NSC187724	Stitch	2.580E-6	3.604E-3	3.635E-2	3.472E-2	4	35
10	CID000003003 Betamethasone-d5	Stitch	2.678E-6	3.604E-3	3.635E-2	3.604E-2	15	1342
11	ctd:C006703 benzo(b)fluoranthene	CTD	3.647E-6	4.462E-3	4.499E-2	4.908E-2	16	1564
12	ctd:C031655 tauroursodeoxycholic acid	CTD	5.254E-6	5.163E-3	5.206E-2	7.071E-2	6	160
13	ctd:C030935 benz(a)anthracene	CTD	6.844E-6	5.163E-3	5.206E-2	9.210E-2	14	1264
14	CID005743054 DFC-28	Stitch	7.123E-6	5.163E-3	5.206E-2	9.585E-2	3	14
15	ctd:D015121 6-Ketoprostaglandin F1 alpha	CTD	7.123E-6	5.163E-3	5.206E-2	9.585E-2	3	14
16	CID000103535 AC1Q6PMP	Stitch	7.194E-6	5.163E-3	5.206E-2	9.681E-2	6	169
17	CID000002290 AC1L1DCL	Stitch	7.571E-6	5.163E-3	5.206E-2	1.019E-1	5	98
18	ctd:D002118 Calcium	CTD	8.213E-6	5.163E-3	5.206E-2	1.105E-1	9	495
19	ctd:D015122 6-Mercaptopurine	CTD	8.309E-6	5.163E-3	5.206E-2	1.118E-1	7	265
20	CID000004742 NSC272671	Stitch	8.500E-6	5.163E-3	5.206E-2	1.144E-1	6	174

Summary

Bones from animals pre-fed with DP displayed downregulation of pathways related to:

- Adhesion
- Inflammation (RA)
- phagosome maturation/lysosomal fusion pathways

DNA damage response genes were upregulated in CD-fed group that received IR; these genes not observed in DP-fed animals exposed to IR

DP appears to protect from IR-induced DNA damage, inflammation and pro-adhesion events in bone

Acknowledgements

Sonette Steczina
Moniece Lowe
Samantha Torres
Ons M'Saad
Bernard Halloran (UCSF)

Gabriella Loots (LLNL)
Aimy Sebastian (LLNL)
Nicholas Hum (LLNL)

Josh Alwood's lab
Eduarduo Almeida and Liz Blaber's Labs

BNL and NSRL teams

SLSTP program

Funding

HRP HHC Omnibus 15-15Omni2-0039 (PI: Schreurs)
NASA Postdoctoral Program – Space Biology
NSBRI Grant #MA02501 (PI: Globus)



Space
Biosciences
NASA AMES RESEARCH CENTER



“Ground control to major Tim...”

<https://www.nature.com/articles/srep21343>



Dried plum diet protects from bone loss caused by ionizing radiation

Bone loss caused by ionizing radiation is a potential health concern for radiotherapy patients, radiation workers and astronauts. In animal studies,...

NATURE.COM