

NASA/TM—2018-219929



# Two-Speed Rotorcraft Research Transmission Power-Loss Associated with the Lubrication and Hydraulic Rotating Feed-Through Design Feature

*Mark A. Stevens*  
*Glenn Research Center, Cleveland, Ohio*

*Mark J. Valco and Kelsen E. LaBerge*  
*U.S. Army Research Laboratory, Glenn Research Center, Cleveland, Ohio*

## NASA STI Program . . . in Profile

Since its founding, NASA has been dedicated to the advancement of aeronautics and space science. The NASA Scientific and Technical Information (STI) Program plays a key part in helping NASA maintain this important role.

The NASA STI Program operates under the auspices of the Agency Chief Information Officer. It collects, organizes, provides for archiving, and disseminates NASA's STI. The NASA STI Program provides access to the NASA Technical Report Server—Registered (NTRS Reg) and NASA Technical Report Server—Public (NTRS) thus providing one of the largest collections of aeronautical and space science STI in the world. Results are published in both non-NASA channels and by NASA in the NASA STI Report Series, which includes the following report types:

- **TECHNICAL PUBLICATION.** Reports of completed research or a major significant phase of research that present the results of NASA programs and include extensive data or theoretical analysis. Includes compilations of significant scientific and technical data and information deemed to be of continuing reference value. NASA counter-part of peer-reviewed formal professional papers, but has less stringent limitations on manuscript length and extent of graphic presentations.
- **TECHNICAL MEMORANDUM.** Scientific and technical findings that are preliminary or of specialized interest, e.g., “quick-release” reports, working papers, and bibliographies that contain minimal annotation. Does not contain extensive analysis.
- **CONTRACTOR REPORT.** Scientific and technical findings by NASA-sponsored contractors and grantees.
- **CONFERENCE PUBLICATION.** Collected papers from scientific and technical conferences, symposia, seminars, or other meetings sponsored or co-sponsored by NASA.
- **SPECIAL PUBLICATION.** Scientific, technical, or historical information from NASA programs, projects, and missions, often concerned with subjects having substantial public interest.
- **TECHNICAL TRANSLATION.** English-language translations of foreign scientific and technical material pertinent to NASA's mission.

For more information about the NASA STI program, see the following:

- Access the NASA STI program home page at <http://www.sti.nasa.gov>
- E-mail your question to [help@sti.nasa.gov](mailto:help@sti.nasa.gov)
- Fax your question to the NASA STI Information Desk at 757-864-6500
- Telephone the NASA STI Information Desk at 757-864-9658
- Write to:  
NASA STI Program  
Mail Stop 148  
NASA Langley Research Center  
Hampton, VA 23681-2199



# Two-Speed Rotorcraft Research Transmission Power-Loss Associated with the Lubrication and Hydraulic Rotating Feed-Through Design Feature

*Mark A. Stevens*  
*Glenn Research Center, Cleveland, Ohio*

*Mark J. Valco and Kelsen E. LaBerge*  
*U.S. Army Research Laboratory, Glenn Research Center, Cleveland, Ohio*

Prepared for the  
AHS International 74th Annual Forum and Technology Display  
sponsored by AHS International  
Phoenix, Arizona, May 14–17, 2018

National Aeronautics and  
Space Administration

Glenn Research Center  
Cleveland, Ohio 44135

## Acknowledgments

This work was sponsored by the NASA Aeronautics Research Mission Directorate (ARMD), Advanced Air Vehicles Program (AAVP), Revolutionary Vertical Lift Technology (RVLT) Project, Two-Speed Drive System Demo: *Demonstrate two-speed drive system with 50% rpm reduction*, at the NASA Glenn Research Center.

Trade names and trademarks are used in this report for identification only. Their usage does not constitute an official endorsement, either expressed or implied, by the National Aeronautics and Space Administration.

*Level of Review:* This material has been technically reviewed by technical management.

Available from

NASA STI Program  
Mail Stop 148  
NASA Langley Research Center  
Hampton, VA 23681-2199

National Technical Information Service  
5285 Port Royal Road  
Springfield, VA 22161  
703-605-6000

This report is available in electronic form at <http://www.sti.nasa.gov/> and <http://ntrs.nasa.gov/>

# Two-Speed Rotorcraft Research Transmission Power-Loss Associated with the Lubrication and Hydraulic Rotating Feed-Through Design Feature

Mark A. Stevens  
National Aeronautics and Space Administration  
Glenn Research Center  
Cleveland, Ohio 44135

Mark J. Valco and Kelsen E. LaBerge  
U.S. Army Research Laboratory  
Glenn Research Center  
Cleveland, Ohio 44135

## ABSTRACT

An investigation was completed into the power loss associated with a rotating feed-through (RFT) design feature used to transfer lubrication and a hydraulic control signal from the static reference frame to a rotating reference frame in the NASA GRC two-speed transmission tests conducted in the Variable-Speed Drive Test Rig. The RFT feature, not commercially available, was created specifically for this research project and is integral to all two-speed transmission configurations tested, as well as a variant concept design for a geared variable-speed transmission presented at AHS Forum 71 in 2015. The experimental set-up and results from measurements in the isolated rotating-feed-through (RFT) experiments are presented. Results were used in an overall power loss assessment for a scaled conceptual 1,000 horsepower inline concentric two-speed transmission to support a NASA Revolutionary Vertical Lift Technologies (RVLT) Technical Challenge, demonstrating 50% speed change with less than 2% power loss while maintaining current power-to-weight ratios.

## INTRODUCTION

Rotorcraft propulsion is a critical element of the overall rotorcraft. Unlike fixed wing aircraft, the rotor/propulsion system provides lift and control as well as forward thrust. As a result, the rotorcraft engine/gearbox system must be highly reliable and efficient. Future rotorcraft trends call for more versatile, efficient, and powerful aircraft, all of which challenge state-of-the-art propulsion system technologies. Variable speed rotors have been identified as an enabler or these new performance goals.

Currently, rotor speed can be varied only a small percentage by adjusting the speed of the engine. This is generally limited by engine efficiency and stall margin permitting speed changes limited to approximately 15% of the maximum operating speed (used in current tilt-rotor applications).

The NASA Heavy Lift Study (Reference 1) concluded that variable speed propulsion is necessary for all aircraft concepts studied. Variable speed propulsion, without loss of efficiency and torque, is necessary to enable efficient high speed operation with reduced noise. The heavy lift study suggests that increased speed variations up to 50% will have a dramatic effect on reducing external noise while increasing rotorcraft performance. Previous NASA variable speed transmission studies concentrated on 15% speed changes

(References 2 and 3). To achieve the greater speed variation capability for the heavy lift application, advanced variable/multi-speed transmission system concepts must be developed.

For the purpose of designing scale developmental hardware to evaluate selected concepts, a 50% speed range was identified as a notional design objective. Speed changes less than the above were thought to be more easily realizable. A relevant maximum input speed of 15,000 rpm, with output speed of 15,000 rpm (high-range hover mode) and 7,500 rpm (low-range cruise mode) was selected for design.

The test article features a modular design offering the ability of testing two interchangeable simple gear train designs, as well as three clutch designs. The gear trains and clutches share common interfaces, allowing assembly of combinations of either of the two gear trains with either of the three clutch designs, resulting in the ability to test six different configurations. The modular approach offers a highly flexible baseline test article, with the added flexibility of focused hardware refinement, while allowing for the retention of hardware not requiring refinement. The result is a highly exploitable, yet economically alterable, baseline test article to identify technology challenges, and evaluate design refinements at the concept demonstration level.

The experimental hardware described in this paper is not intended to replicate flight quality hardware. Consideration

of light weight design yielded to that of a flexible and easily accessible, easily modifiable design that can be exploited in the test cell environment, although some limited aspects of the design are lightweight, such as the gear trains.

This overview includes a review of design requirements and an overview of cross sections of the four of six possible modular test transmissions. Four configurations of the six possible are in various states assembly and experimentation at NASA GRC to evaluate performance and operational capability of the concepts.

### Current Work

This paper is a follow on to earlier work on the design and tests of viable concepts for both two-speed and variable speed transmissions (Ref. 4). This paper overviews the GRC two-speed test transmission and focuses on current research work, determining the magnitude of component power loss for a key component that is common to all of the two-speed transmission configurations, the hydraulic rotating feed-through (RFT). Shaft speed and torque were measured in isolated component experiments. This data enabled determination of the power loss distribution of the existing transmission configurations and also for future design.

## TWO-SPEED TRANSMISSION DESCRIPTION

The fractional scale research transmission is a development model for an inline concentric transmission arrangement intended to be an add-on unit, or directly integrated into the overall design of a propulsion drive system. Figure 1 shows a representative tilt rotor drive system schematic and the subject two-speed changer located between the engines and main combiner gearbox where power transfer is at high-speed and low-torque.

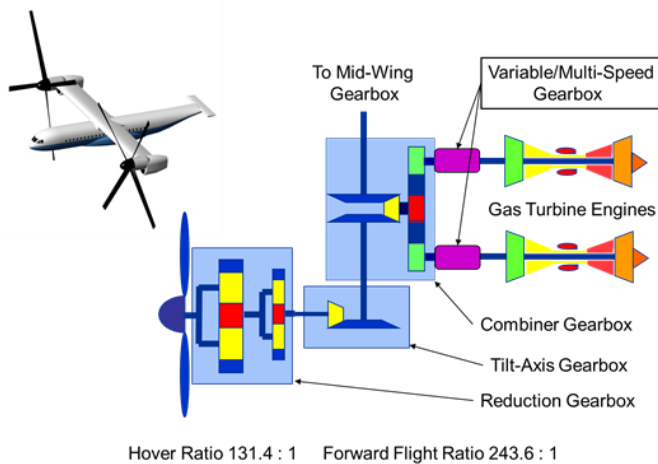

Figure 1. Propulsion Drive System Schematic.

### Identification of Concepts and Down Selection

An earlier study was completed that identified a large number of possible multi and variable speed transmissions (Reference 4). The study included a broad number of possible transmission arrangements found in the open literature and also a number of original concepts. A set of criteria was established enabling down selection identifying the top three potential candidates for development and test (Reference 5). The primary metric for selection was simplicity, seen to translate to a light weight and robust design. Three concepts were selected meeting the above. Based on available funding, the two two-speed transmission concepts were designed and manufactured. The two concepts evolved into a modular configuration creating the ability to test multiple gear and clutch combinations.

### Design Requirements

The design requirements are summarized in Table 1 and a representative aircraft mission cycle is defined in Table 2.

Table 1. Test Article Design Requirements.

250 HP nominal (200 HP facility capacity)
Input Speed - 15,000 rpm
Output Speeds - 15,000 rpm (hover), 7,500 rpm (cruise)
Employ straight spur gear geometry (budget consideration)
Drive should fail safe to high-speed (hover) mode
<sup>a</sup> Provide high-speed positive drive locking-element
Lubricant - DOD-PRF-85734A, synthetic ester-based oil
40C 104F 23.0 cSt
100C 212F 4.90-5.40 cSt
-54C -65F pour point
Inline configuration (input-output shafts)
<sup>b</sup> Lightweight rotating components (flight like)
<sup>c</sup> Housing design (modular, possibility of windage shrouds)

<sup>a</sup> requirement dropped due to complexity and budget

<sup>b</sup> requirement dropped due to scope and budget

<sup>c</sup> not an original requirement

Table 2. Mission Cycle: High Speed / Low Speed Ranges.

Operation	Time (minutes)	Notes
Taxi	4	
Ground check	1	(60% power)
Climb to cruise	25-30	
Convert (shift 1:1 → 2:1)	2	(Period TBD)
Cruise	180	
Transfer altitude	20	
Final approach	5	
Convert (shift 2:1 → 1:1)	2	(Period TBD)
Vertical landing	1	
--		
High Speed Operation	60	→ ~25% (TBD)
Low Speed Operation	180	→ ~75% (TBD)

(Adapted from Reference 6.)

## Concept Schematic

An initial impetus for a simple lightweight transmission was based on the notional schematic shown in Figure 2.

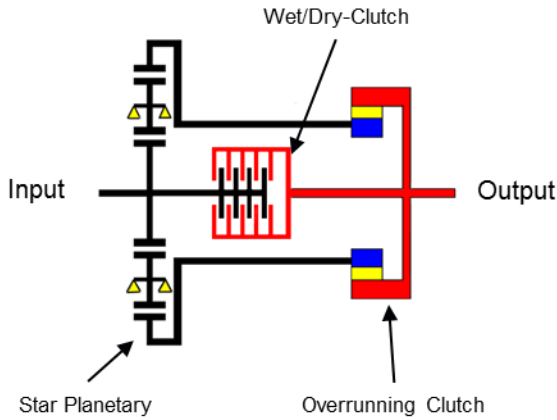

High Speed: W/D Clutch Engaged, Overrunning Clutch Free Wheel  
 Low Speed: W/D Clutch Disengaged, Overrunning Clutch Driving

**Figure 2. Initial Concept Schematic.**

## Two-Speed Transmission Modules & Configurations

Modules. The test article design is comprised of five modules consisting of two interchangeable gear trains and three interchangeable clutch systems in a single housing structure as shown schematically in Figure 3 below.

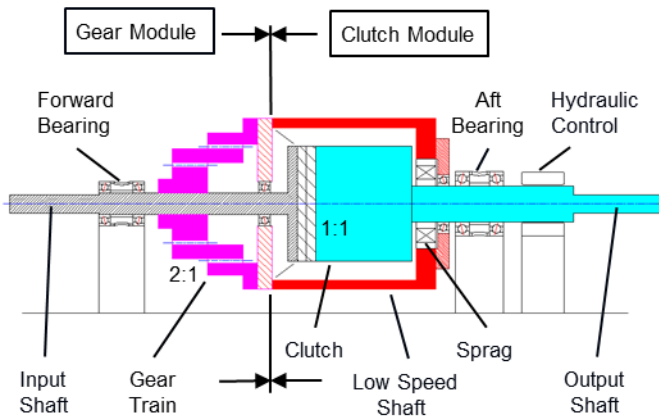

**Figure 3. Modules Schematic.**

Hover mode, high-speed 1:1 ratio, is transferred through the central shafts when the clutch is engaged. Cruise mode, low-speed ~2:1 reduction ratio output, is transferred through the gear train, to the low speed shaft, through the sprag, returning to the output shaft when the clutch is released. All gear trains employ spur gears for lower cost.

The following sections provide a brief overview of each module of the overall two-speed transmission. Further detail on design and early tests is contained in References 7 and 8

respectively. Following the overview of modules, the subject RFT and related hardware are discussed in detail at the component and function level.

Offset Compound Gear Train (OCG). The OCG consists of an input gear with external teeth, an output ring gear with internal teeth, and a cluster gear with internal teeth on the input end and external teeth on the output end, mating with the input and output gears, and running on a centerline offset from the main machine axis. The OCG has two meshes and four basic bearings, two at the cluster gear and two at the input shaft. The duplex bearing pair at the input shaft is considered as one bearing. The OCG is shown in Figure 4.

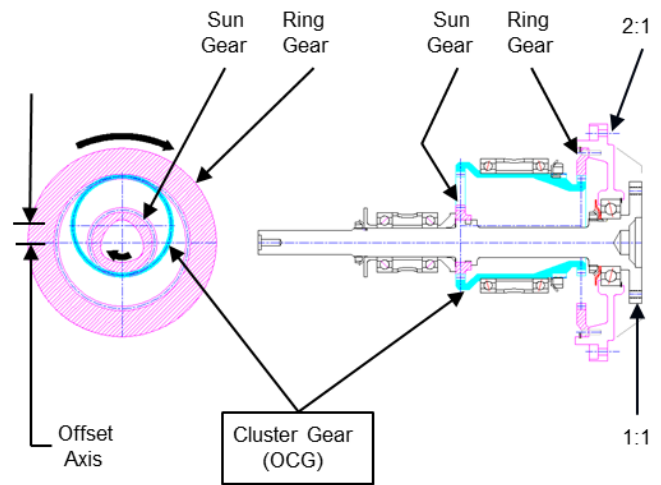

**Figure 4. OCG Gear Train Module.**

Dual Star-Idler Planetary Gear Train (DSI). Similar to the OCG, the DSI consists of an input gear with external teeth, a ring gear with internal teeth, and the OCG cluster gear is replaced by three star gear pairs, where the first meshing gear is a planet gear and the second meshing planet gear serves as an idler, reversing the direction of rotation of the ring gear, so that both the input gear and ring gear rotate in the same direction as shown in Figure 5. Note that the lack of reverse rotation idler gears was an oversight in the simple planetary baseline schematic (refer to Figure 2) where the input and output gears rotate in opposite directions.

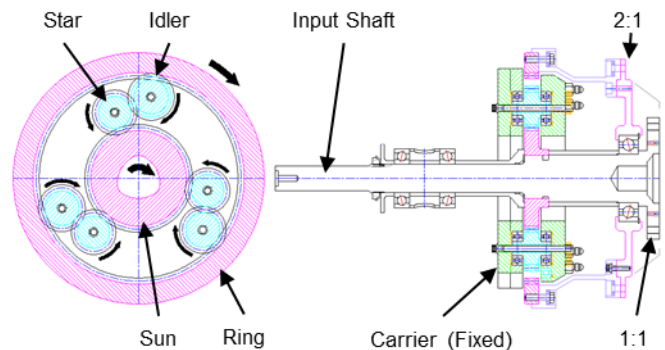

**Figure 5. DSI Planetary Gear Train Module.**



**Dry-Clutch (DC).** The dry-clutch is a commercially available small diameter high-performance automotive clutch. Selection was based on prior experience and thought to be the quickest to integrate into the overall design and thought to be the new research facility operational. A number of design modifications were made to meet the design requirements. The dry-clutch arrangement is shown below in Figure 6.

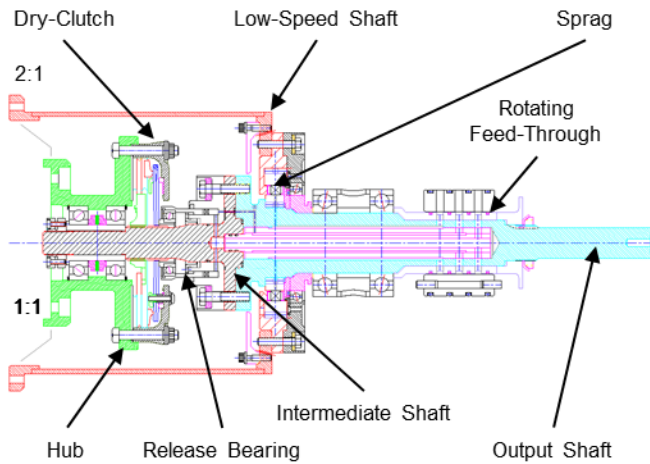

**Figure 6. Dry-Clutch Module.**

**Alternate Dry-Clutch (ADC).** The ADC was conceived based on reconsidering an initial design requirement that “the drive should fail safe to high-speed (hover) mode”. In the ADC, operation is opposite to that of the original dry-clutch, reversing hydraulic-release and mechanical-drive, to hydraulic-drive and mechanical-release. The ADC retains the same drive and driven plates but features a new cover (housing) with an integral annular piston that applies the drive clamping force. The ADC, with lower required hydraulic pressure due to increased piston area, directly effects efficiency at the RFT with lower ring seal friction torque. The ADC arrangement is shown below in Figure 7.

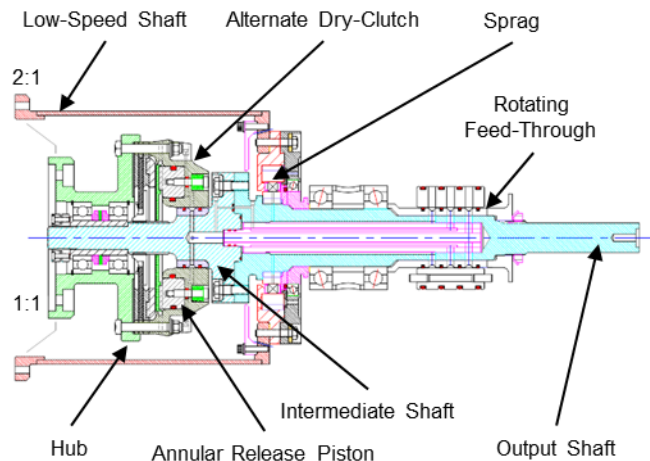

**Figure 7. Alternate Dry-Clutch Module.**

**Wet-Clutch (WC).** The wet clutch design is loosely based on friction/steel drive/driven elements of traditional automotive automatic transmission design and uses commercial automotive wet friction/steel drive plates. A significant difference in the design compared to common automotive applications is that the clutch is controlled in an opposite manner. Mechanical springs provide clamping forces to transfer power through the drive plates and hydraulic pressure is used to release the drive plates. The above meets the original basic design requirement to fail safe in the high-speed 1:1 direct drive mode due to a loss of hydraulic pressure. The wet-clutch is shown in Figure 8.

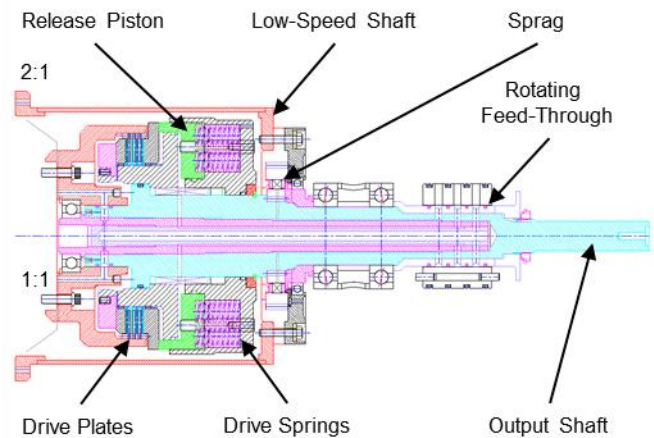

**Figure 8. Wet-Clutch Module.**

**Transmission Configurations.** Elevation cross sections for each transmission configuration are shown in Appendix A.

**Transmission Housing: Stations, Module Interfaces, and Bearing Locations.** The housing consists of a precision ground base plate with multiple bearing supports. Each support is horizontally split on the center of rotation to form a lower saddle and upper cap and includes integral features for oil jet lubrication and instrumentation. Longitudinal and transverse rails, both above and below the base plate, add to the stiffness and provide mounting surfaces for side and end walls. The base and supports are shown in Figure 9.

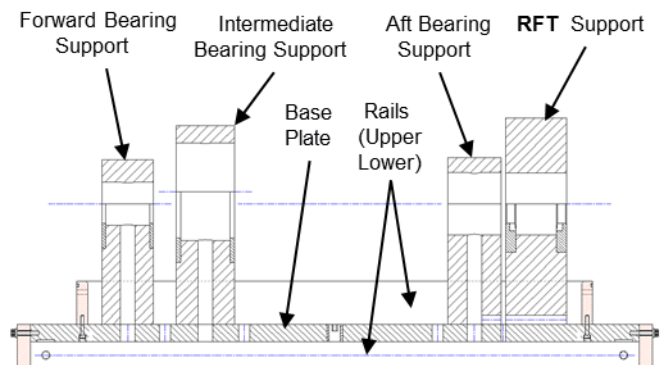
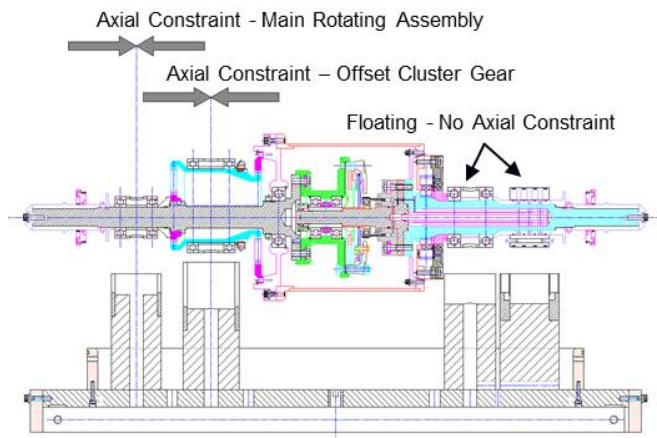

**Figure 9. Housing and Supports.**



The saddle-cap bearing support arrangement is analogous to an axial-split housing where the entire rotating assembly is first assembled and installed within the split housing. The OCG and DSI gear trains each have a unique support design. The input shaft bearing support, output shaft bearing support, and RFT, are positioned to common fixed stations.

Axial position of the overall rotating assembly is controlled at the gear trains as shown in Figure 10. The overall rotating assembly position is constrained at the input shaft duplex bearing set. The OCG cluster gear position is controlled by the cluster duplex bearing set and the DSI carrier frame is keyed to the support controlling planet gear axial position and anti-rotation. The output shaft duplex bearings are free to float axially without changing the bearing axial preloads. The RFT has no bearings and is non-contacting with the exception of the ring seals.



**Figure 10. Axial Constraints.**

Most lubrication entry points are located integral in the base. The RFT and main duplex bearings are supplied through the aft end wall that are split at the shaft centerline for removal. Commercial non-contacting labyrinth seals, splash shields, and shaft oil slingers are used at the end walls. Lubricant drains are machined in the base plate and sump pans are attached from below where the fluid is scavenged.

## ROTATING FEED-THROUGH (RFT) DESCRIPTION

### Clutch Control and Lubrication

**Output Shaft (Fluid Passages).** The inline concentric two-speed transmission features a multi-passage shaft to provide fluid transfer for both sprag and bearing lubrication, as well as to provide hydraulic clutch control. Both the dry-clutch and the wet-clutch include an output shaft designed with three co-axial passages. The wet-clutch output shaft is more complex than the dry-clutch output shaft. Added complications include increased shaft length and the addition

of a male polygon drive feature for the mating clutch hub. Differences relative to the dry-clutch output shaft are mainly due to the use of specific commercial and NASA designed parts that make up the dry-clutch design, as well as decomposing the dry-clutch shaft into intermediate and aft sections. For the discussion of fluid passages, the wet-clutch output shaft is shown in Figure 11.

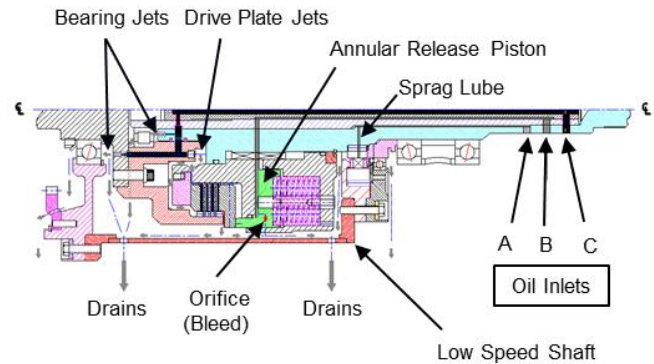

**Figure 11. Output Shaft and Hydraulic Passages (typical passages; Wet-clutch depicted).**

Oil flow passage “A” provides lubrication to the sprag and aft-support bearing, “B” provides hydraulic pressure to the clutch release piston, and “C” provides lubrication to bearings and clutch friction/steel plates and drive teeth. The flows and drains are also shown. Continuous “bleed” at the piston chamber is provided by two orifice flow inserts.

The output shaft is a three-piece non-separable assembly consisting of a gun drilled primary outer shaft and two heat-shrink interference fit concentric inserts. Following the above assembly, final machining of the exterior is completed (i.e. grinding bearing journals and polygons). Radial passages connecting the three annular passageways to the outside diameter near the aft end of the shaft at the RFT station are electrical discharge machined (EDM) to preclude trapping machining chips that may result from conventional cutting-edge machining. The shaft is dynamically 2-plane balanced as an individual part.

**Rotating Feed-Through (RFT).** The RFT is a multi-passage device used to transfer the fluid from a static non-rotating reference to the three individual passages in the rotating shaft to lubricate/cool the sprag, provide lubricant to other areas (wet-clutch only), and to provide the hydraulic clutch control signal. No commercial product having the above functionality was identified that met the physical size and location requirements, and speed requirements. Available products lacked the required physical size and were generally speed limited to approximately 5,000 rpm or less. Products having the required speed capability were typically both size and passage count limited. To meet the two-speed transmission requirements, a three-passage design was developed using ring seals. The higher pressure passages for

the hydraulic clutch release signal are positioned at passage “B” in Figure 11 above (Passage “B” and “C” in the dry-clutches). Passages providing lower pressure lubrication flow are positioned outward of the above to reduce the net pressure differentials across the ring seals. Pressure for the dry-clutch was higher than required for the wet-clutch and was governed by clutch release force to overcome the mechanical springs and existing design release piston size.

The RFT is comprised of three basic parts, the stator, mounted in the stationary RFT support, the rotor, mounted on the rotating shaft, and ring seals, separating and sealing the passages between the rotor and stator.

The stator is sealed at the exterior with static o-rings and at the interior with ring-seals. The stator has two anti-rotation pins that engage in the RFT support housing. The rotor is shaft mounted and includes four external grooves for the ring seals and three circumferential grooves with six radial passages to provide uninterrupted flow during rotation. The three-passage RFT is shown in Figure 12.

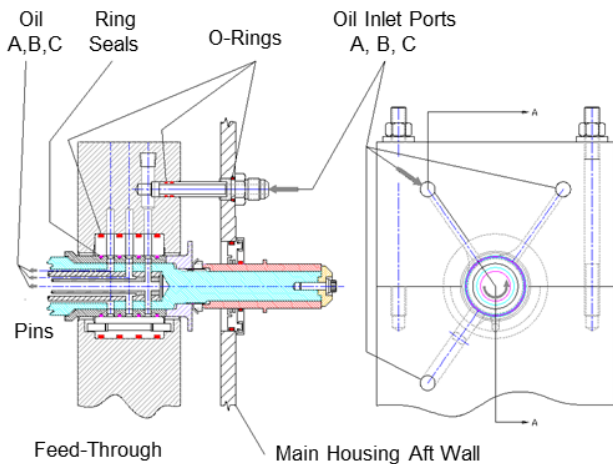

**Figure 12. Hydraulic RFT and Support.**

The shaft mounted RFT rotor sleeve with four ring seals installed highlighting the three annular fluid grooves and three of the six radial passages (three are diametrically opposed) is shown in Figure 13. Aft slinger is not shown.



**Figure 13. RFT Shaft Mounted Rotor and Ring Seals.**

### Rotating Feed-Through and Ring Seal Operation

Pressure forces applied to ring seals, relative to the RFT stator sleeve and rotating rotor sleeve (mounted on output shaft), are shown in a simplified image below in Figure 14.

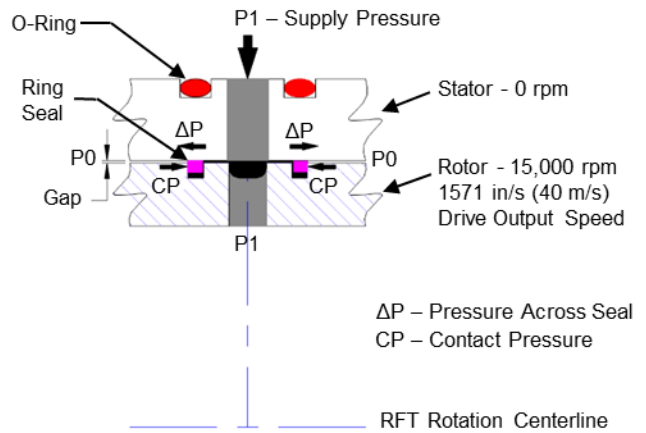

**Figure 14. RFT Sealing Arrangement Detail.**

P1 is the fluid supply pressure at the RFT housing and P0 is the pressure on the opposite side the ring seal within the radial clearance (noted as gap in figure) between the RFT rotor and stator. P0 may be atmospheric, internal to the gearbox, or the pressure of an adjoining passage depending upon its relative position within the multi-passage RFT.

The ring seal outside diameter is close fit mating with the stator bore. The inside diameter of the ring seal is designed to provide clearance at the circumferential rotor groove. In addition, the ring seal is narrower than the circumferential rotor groove. The above geometry allows the ring seal to move to one side or the other, also applying supply pressure P1 at the inside diameter of the rings seal and a radial outward pressure at the outside diameter resulting in the rings remaining predominately stationary. The opposing pressure, Po, is only applied to exposed face area of the ring seal within the clearance.  $\Delta P$  is applied to the net area of the face of the ring seal in contact with the rotor at the side of the circumferential rotor groove (reference: 2 inch nominal ring seal diameter). Note that the contacting area between the ring seal and rotor is less than the pressurized area on the opposite side of the ring seal, resulting in a higher net contact pressure.

### Ring Seal Material Usage in Production Automotive Automatic Transmissions.

Both metal and nonmetallic ring seals are used in automatic transmissions. A number of nonmetallic seal materials are used in newer applications with changes related to enhanced performance. Some commercially available nonmetallic ring seal materials and associated operating points as surveyed and summarized are shown in Figure 15 (Reference 9).

Figure 15 shows a range of materials and their performance as a function of operational pressure and sliding speed as used in fifty production multi-speed and variable-speed automatic automotive transmissions. Two of the materials are used in the GRC two-speed transmissions. Vespel®, a polyimide, split rings are used in the RFT, and Teflon (PTFE) solid (non-split) rings are used in the ADC.

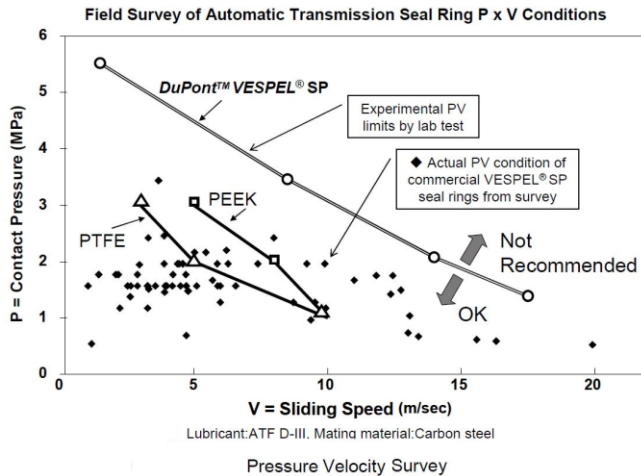

**Figure 15. Ring Seals in Automotive Applications (Reference 9.)**

Initially metal ring seals were used in the RFT but were observed to experience high rates of wear. This was partly due to the high release pressure required for the dry-clutch as well as the high operating speeds. Vespel® rings seals, coupled with lower pressures resulting from modifications to the dry-clutch, and by design in the wet-clutch and alternate dry-clutch, significantly reduced ring wear at the RFT in the high pressure passage(s) compared to metal ring seals.

**Ring Seal Considerations**

Contact pressure and sliding speed are two parameters that influence ring seal performance. The design of other components that receive the fluid passing through the RFT can impact ring seal performance. It was pointed out that the dry-clutch release force was reduced by modifying the clutch spring stiffness, and has a direct impact on the pressure within the RFT passage. A further reduction in release pressure could be obtained by increasing release piston area. This was not possible with the dry-clutch due to the existing annular piston diameter used in the commercial hydraulic release bearing. Within the wet-clutch design, the release piston area is increased to offset a higher clamping force (higher release pressure) due to lower coefficients of friction for wet-friction drive materials as compared to dry friction materials.

In the wet-clutch design, the reduced release pressure is on the order of twice the bearing lubrication pressure, or 145 psi (1MPa), resulting in a differential pressure drop across the ring seals nearly equal to that of the pressure drop of the

sprag lubrication passage to atmosphere (gearbox internal pressure). The above yields a uniform pressure distribution across all ring seals resulting in improved pressure loads. The ring seals used for the wet-clutch performed well with the reduced pressure differentials.

**RFT POWER LOSS EXPERIMENT HARDWARE**

An aspect in the development and design of a two-speed rotorcraft transmission is management of power losses associated with the transmission components. Power loss leads to increased engine power required and generates heat that often requires incorporation of appropriately sized heat exchangers for heat dissipation. The additional power and heat exchangers add weight to the system. Therefore, managing and minimizing power loss is an important aspect in the design of a two-speed rotorcraft transmission.

Based on prior analytical estimates, RFT ring seal torque was identified as a potential significant contributor to overall system power loss. The RFT warranted experimental investigation into power loss for the differing operating requirements associated with the three clutches as well as for differing operational conditions during hover and cruise.

Taking advantage of the two-speed transmissions modular design, an isolated RFT experiment was set up to measure ring seal torque. The general RFT ring seal experimental set-up used to measure ring seal frictional torque in the two-speed transmissions is shown below in Figure 16.

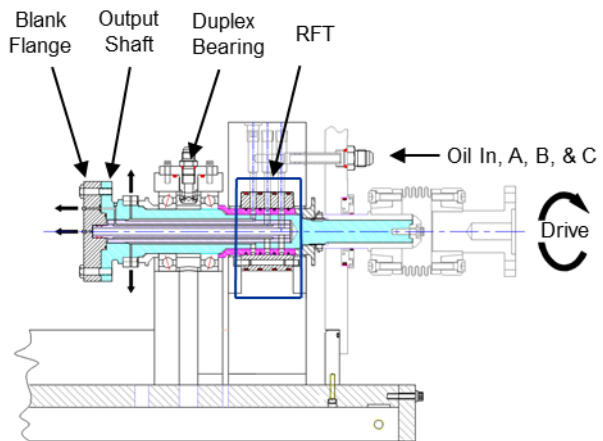

**Figure 16. RFT Torque Measurement Experiment.**

The isolated RFT experimental set-up utilizes mostly existing hardware, the output bearing support, rotating RFT support, and output shaft. The forward end of the shaft is capped with a test specific flange with integral machined passages. Passages A, B, and C are either sealed with plugs or open orifice jets, to simulate actual conditions for the two-speed transmission designs and operating conditions. For this test, the facility output motor (energy absorber), is used

to drive the shaft. Initially the RFT is run over the speed range with no ring seals to obtain the baseline tare torque associated with the duplex bearings. The ring seals are then installed straddling passages, A, B, and C. Lubricant conditions in the passages simulate hover and cruise modes for the two-speed transmission arrangements below:

Configuration 1: OCG / Dry-Clutch (ref. Figure A1\*)

Configuration 3: OCG / Wet-Clutch (ref. Figure A3\*)

\* Two-Speed Configuration are shown in Appendix A.

The above configurations were selected based on prior tests of the OCG and DSI gear trains with the dry-clutch where it was concluded that the gear trains had negligible effect on overall two-speed transmission system operation and that differences were clutch dominated. The simpler OCG was then used to test all clutches for direct comparison.

### Aspects and Limits of the RFT Experimental Set-Up

The RFT experimental setup minimized overall component count to simplify the measurement of power loss associated specifically with the RFT to the extent possible. Torque, which includes frictional losses from the RFT ring seals and the duplex bearing support, was measured at the output shaft torque meter. Power loss was then determined from the measured torque and shaft speed, with torque equating to the sum of the torque due duplex bearings and the RFT ring seal friction torque. The tare duplex bearing torque was measured and subtracted to obtain RFT ring seal power loss.

Unfortunately, operating the shaft supported only by a single duplex bearing pair and flexible drive coupling connecting to the drive motor introduced a different set of rotordynamic conditions than that of a full two-speed transmission. Due to shaft rotordynamic response, the maximum operating speed for the RFT experiments was limited to 10,000 rpm.

## RFT EXPERIMENTS AND RESULTS

### RFT Experimentation and Data Acquired

The experimental setup included sensors to measure and record shaft speed, torque, lubricant supply flow rates and pressures, clutch hydraulic passage supply pressure, several lubricant and coolant temperatures, several accelerations, chip detector, and facility monitoring parameters such as motor coolant flow and motor coolant supply pressure. Calculated parameters include: power, angular velocity, and angular acceleration. To measure the relatively small torque magnitudes associated with the anticipated low power loss values for the experimental set-up, the torquemeter was calibrated with small static weights on a torque arm. Since steady-state power loss data was being sought, acquired sensor data was recorded at a rate of 5 Hertz. The facility has a dedicated external lubrication system that supplies filtered lubricant (DOD-L-85734 Ref. Table 1) to the experimental hardware. Heated lubricant from the supply tank is pumped through a heat exchanger to control

temperature. Lubricant is scavenged from the experimental hardware sumps and recirculated to the supply tank.

The experiments were run with the drive motor in “Speed” control mode where the operating speed is specified and the facility motor control system provides feedback control to hold the motor speed at the specified set point.

Lubricant supply pressure conditions to each channel of the RFT hydraulic passages replicated the RFT operating conditions for both hover and cruise mode. Experiments measured total friction torque for the RFT ring seals and the shaft support duplex bearing. Separate experiments were performed with the RFT seals removed to measure the power loss associated with the duplex bearing. Lubrication to the duplex bearing is independently supplied to static mounted oil jets and does not contribute to torque associated with the RFT component. For the experiments, hydraulic pressure to the three separate RFT passages were set differently depending on the specific transmission arrangement and operating mode. Friction torque from the RFT ring seals is related to oil flow for lubrication and hydraulic pressure for clutch control. Multiple experiments were conducted to measure RFT torque with fluid passage supply pressures set for the dry-clutch or wet-clutch transmission arrangements. The lubricant supply was set at 80 psi and 160 °F and clutch hydraulic pressure was operated between 0 and 375 psi depending on the transmission clutch and flight mode condition.

The RFT has three separate passages for lubricant pressure and flow. The center passage shares its ring seals with the adjacent end passages. The outer ring seal on the outer passages experience a differential pressure between the outer passage lubricant pressure and ambient atmospheric pressure. Power loss friction torque for a ring seal is related to: 1) the seal sliding due to differential surface velocities for the stationary RFT stator and the rotating output shaft; and 2) the differential pressure across each ring seal.

The following nomenclature is used to indicate the RFT passage hydraulic pressure condition used in an experiment:

toward clutch ← | A | B | C | → toward output shaft end

For example, for the Dry-Clutch two-speed rotorcraft research transmission in cruise mode, the RFT “A” passage, closest to the clutch assembly, is set at 80 psi pressure, while the RFT “B” center passage, and the RFT “C” passage, closest to the output shaft end, are both set at 375 psi hydraulic pressure. Using the nomenclature convention this condition is identified as: |80|375|375|.

### Data Analysis and Trends

Numerous experiment runs were conducted to capture steady-state data across a range of shaft speed conditions and RFT hydraulic pressure conditions to simulate hover mode and cruise modes for the two-speed rotorcraft research



transmissions with both Dry Clutch and Wet-Clutch. The acquired torque data was processed to isolate steady-state conditions using the following parameters between time consecutive data points:

- Angular shaft acceleration  $< \pi/20$  rad/s<sup>2</sup>
- Lube supply pressure change  $< 0.4$  psi/s (nominal 80 psi)
- Clutch supply pressure change  $< 1.0$  psi/s

The steady-state torque data (less duplex bearing tare torque) was processed for each RFT hydraulic pressure condition and the linear least squares method was used to fit an equation to the data to relate ring seal friction torque to shaft speed. A plot of the resulting ring seal torque for the Dry-Clutch and Wet-Clutch configurations are shown in Figure 17 and Figure 18 respectively.

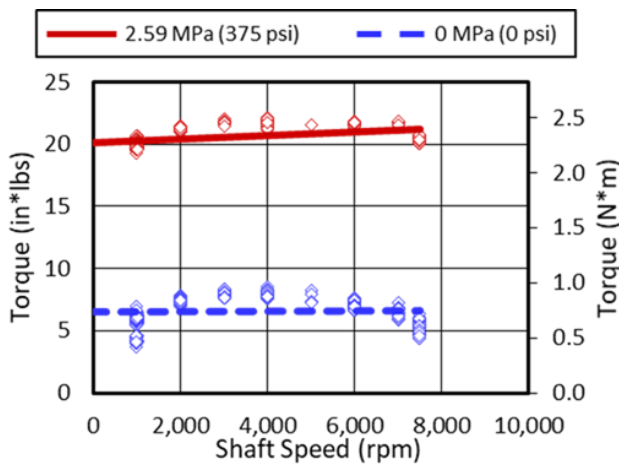

Figure 17. RFT Ring Seal Torque vs. Speed for the Dry-Clutch Configuration at Indicated Clutch Pressure.

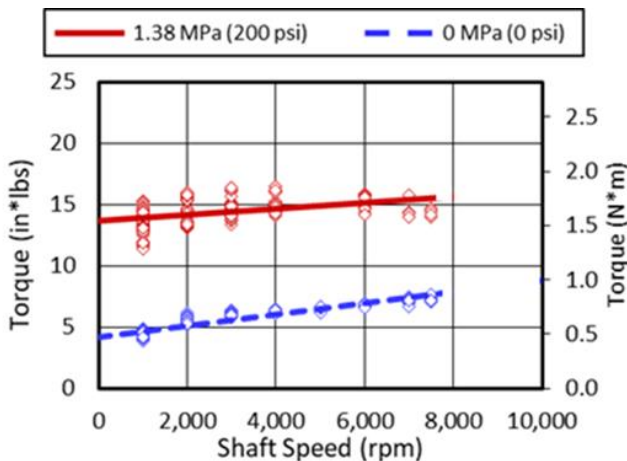

Figure 18. RFT Ring Seal Torque vs. Speed for the Wet-Clutch Configuration at Indicated Clutch Pressure.

Experimental data linear trend line correlation coefficients, $r^2$	Dry Clutch	Engaged $r^2 = 0.0008$ ; Disengaged $r^2 = 0.2$
	Wet Clutch	Engaged $r^2 = 0.9$ ; Disengaged $r^2 = 0.2$

The torque trend line equations were extended to power loss trend line equations shown below and plotted for the Dry-Clutch in Figure 19.

Dry-Clutch disengaged (cruise):  
| 80 psi (sprag) | 375 psi (clutch) | 375 psi (clutch) |

$$\begin{aligned} \text{Torque (in-lb)} &= 1.4E-4 \times \Omega + 20 \\ \text{Power (hp)} &= 2.4E-9 \times \Omega^2 + 3.2E-4 \times \Omega \\ \text{Torque (N-m)} &= 1.6E-5 \times \Omega + 2.3 \\ \text{Power (Watts)} &= 1.7E-6 \times \Omega^2 + 2.4E-1 \times \Omega \end{aligned}$$

Dry-Clutch engaged (hover):  
| 80 psi (sprag) | 0 psi (clutch) | 0 psi (clutch) |

$$\begin{aligned} \text{Torque (in-lb)} &= 1.2E-5 \times \Omega + 6.5 \\ \text{Power (hp)} &= 1.9E-10 \times \Omega^2 + 1.0E-4 \times \Omega \\ \text{Torque (N-m)} &= 1.4E-6 \times \Omega + 0.73 \\ \text{Power (Watts)} &= 1.4E-7 \times \Omega^2 + 7.7E-2 \times \Omega \end{aligned}$$

Where  $\Omega$  is shaft speed in revolutions per minute.

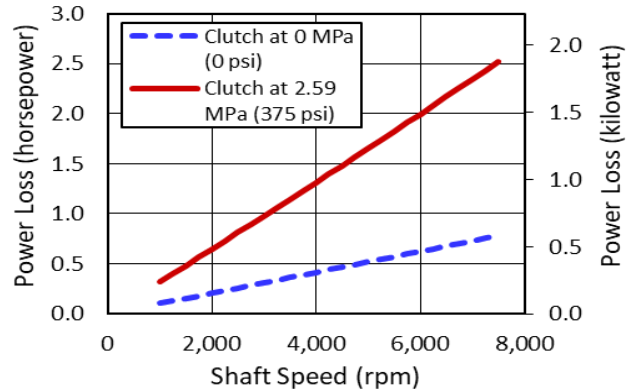

Figure 19. Rotating Feed-Through Power Loss for Dry-Clutch Configuration.

Similarly the torque and power loss trend line equations are provided below and plotted for the Wet-Clutch in Figure 20.

Wet-Clutch disengaged (cruise):  
| 80 psi (sprag) | 200 psi (clutch) | 80 psi (bearing lube) |

$$\begin{aligned} \text{Torque (in-lb)} &= 2.4E-04 \times \Omega + 14 \\ \text{Power (hp)} &= 3.9E-09 \times \Omega^2 + 2.2E-04 \times \Omega \\ \text{Torque (N-m)} &= 2.8E-05 \times \Omega + 1.5 \\ \text{Power (Watts)} &= 2.9E-06 \times \Omega^2 + 0.16 \times \Omega \end{aligned}$$

Wet-Clutch engaged (hover):  
| 80 psi (sprag) | 0 psi (clutch) | 80 psi (bearing lube) |

$$\begin{aligned} \text{Torque (in-lb)} &= 4.7E-04 \times \Omega + 4.1 \\ \text{Power (hp)} &= 7.4E-09 \times \Omega^2 + 6.5E-05 \times \Omega \\ \text{Torque (N-m)} &= 5.3E-05 \times \Omega + 0.46 \\ \text{Power (Watts)} &= 5.5E-06 \times \Omega^2 + 4.9E-02 \times \Omega \end{aligned}$$

Where  $\Omega$  is shaft speed in revolutions per minute.

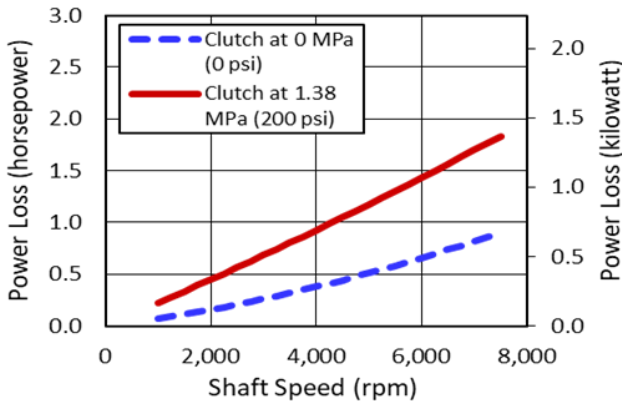

**Figure 20. Rotating Feed-Through Power Loss for Wet Clutch Configuration.**

### Generalized Ring Seal Power Loss Equation

Using trend line functions that were fit to the experimental data for the Dry Clutch and Wet Clutch hydraulic pressure conditions applied to the RFT, an attempt was made to develop a generalized equation for ring seal power loss as a function of shaft speed and differential pressure across a ring seal. For example the DC [80|0|0] condition was treated as two ring seals with an 80 psi pressure differential on each ring seal. Similarly, the WC [80|0|80] condition represents four ring seals with 80 psi pressure differential on each ring seal. The WC [80|200|80] condition represents two ring seals with 80 psi pressure differential and two ring seals with 120 psi pressure differential. The same reasoning was applied to the DC [80|375|375] yielding one seal with 80 psi pressure differential, one seal with 295 psi pressure differential, and one seal with 375 psi pressure differential.

The coefficient in each trend line function for each condition was scaled by the sum total pressure differential within the RFT. For example, for the WC [80|200|80] condition the scaling was factor was  $80+120+120+80 = 400$  psi total differential pressures. After scaling each trend line function for the two DC and two WC pressure conditions, the coefficients from the four equations were averaged to develop the following generalized power loss equations for one ring seal with a given pressure differential  $\Delta P$  (in psi or MPa).

$$\begin{aligned} \text{Torque (in-lb)} &= (5.8E-07 \times \Omega + 2.8E-02) \times \Delta P \\ \text{Power (hp)} &= (9.2E-12 \times \Omega^2 + 4.5E-07 \times \Omega) \times \Delta P \\ \text{Torque (N-m)} &= (6.6E-08 \times \Omega + 3.2E-03) \times \Delta P \\ \text{Power (W)} &= (6.9E-09 \times \Omega^2 + 3.4E-04 \times \Omega) \times \Delta P \end{aligned}$$

These generalized ring seal power loss equations are simplifications that can provide broad approximations for ring seal power loss and in some cases yield considerable deviations from the experimental measurements. The generalized ring seal power loss equations were compared

with the trend line power loss estimates for each DC and WC condition. The percent error deviations between the trend line equations and the generalized equation are shown in Table 3 for 1,000 rpm and 7,500 rpm shaft speed.

**Table 3. Comparison of Power Loss from Experimental Data Trend Line Equations with Power Loss Estimates from the Generalized Ring Seal Power Loss Equation.**

Clutch Drive Ratio	RFT Passage			Pres. Diff. $\Delta$ PSI	% Error	
	A (psi)	B (psi)	C (psi)		1,000 Rpm	7,500 rpm
DC 1:1	80	0	0	160	-28 %	-20 %
DC 2:1	80	375	375	750	7.8 %	16 %
WC 1:1	80	0	80	320	103 %	34 %
WC 2:1	80	200	80	400	-16 %	-15 %

Graphs comparing the power loss between the experimental data trend line and the generalized power loss equation are shown in Figure 21 for the Dry-Clutch configuration and in Figure 22 for the Wet-Clutch configuration.

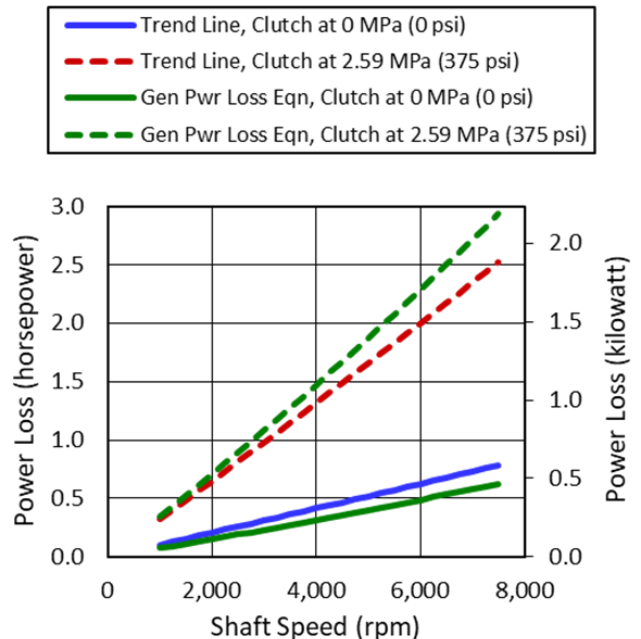

**Figure 21. Comparison of RFT Power Loss between the Experimental Data Trend Line and the Generalized Power Loss Equation for the Dry Clutch Configuration, | 80 psi (sprag) | Clutch | Clutch |**

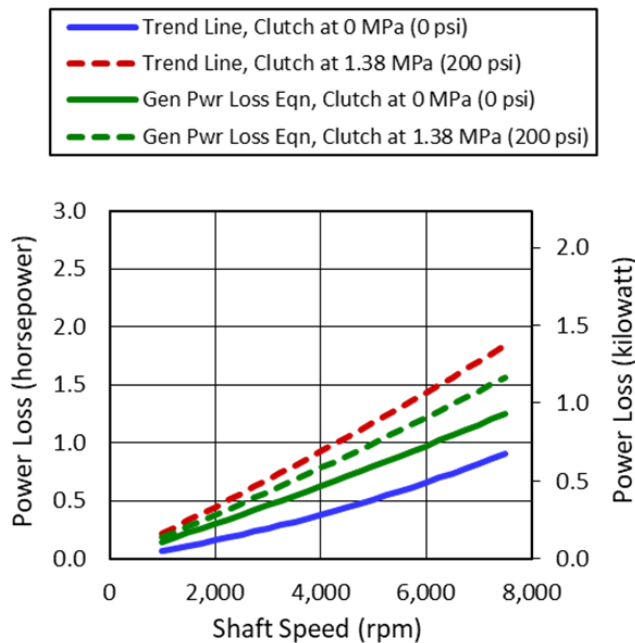

**Figure 22. Comparison of RFT Power Loss between the Experimental Data Trend Line and the Generalized Power Loss Equation for the Wet Clutch Configuration, | 80 psi (sprag) | Clutch | 80 psi |**

### Ring Seals at the Alternate Dry-Clutch (ADC)

In the initial two-speed transmission design, ring seals were only used in the RFT. Derivative RFT designs were incorporated into other conceptual transmission designs and the ADC design (overviewed earlier; refer to Figure 7).

The ADC design requires transferring the hydraulic control from the output shaft to the annular piston contained within the ADC cover (housing), that is attached to the intermediate hub that is attached to the aft end of the input shaft. The above requires a single passage straddled by two ring seals.

In support of the above, additional experiments were performed using the same hardware as in Figure 16, except that only a single passage was sealed by two solid (non-split) Teflon ring seals, as employed in the ADC design, to simulate the actual pressure differentials that the ring seals experience at the ADC. Solid ring seals were selected to minimize lubricant from reaching the carbon drive/driven plates used in the ADC. Test speeds and pressures simulated design conditions within the ADC clutch. Tests for this area focused on minimizing leakage, not on power loss.

Ring seals used at the ADC conditions differ from the original DC, and also differ from those in the RFT. Within the ADC, at 15,000 rpm input design speed, ring seal speed is limited to a differential speed of 0 rpm to 7,500 rpm. At hover, the relative differential speed is 0 rpm with a pressure of 200 psi since the ADC clutch is engaged (hover 1:1, ADC clutch engaged transferring power and sprag is overrunning). At cruise, the relative differential speed is 7,500 rpm and a

pressure of 0 psi (cruise 2:1, ADC clutch released and power transferred through the sprag).

Both of the above steady-state conditions are more benign on the ring seals than during shifts. The most severe shift is the cruise-to-hover, 2:1 to 1:1 upshift, where pressure is ramped from 0 psi to 200 psi concurrently with differential speed decreasing from 7,500 rpm to 0 rpm, as the carbon drive and driven plates slip and engage when the output shaft reaches the same rpm as the input shaft. Down shifting from hover 1:1 to cruise 2:1 is also benign as the ADC clutch is released, and the output shaft slows until the speed matches the low speed shaft, and the sprag clutch engages.

As stated earlier, the goal of these tests was to verify favorable operation of the ADC with no concern of associated local power loss for these two ring seals. Any significant power loss occurs at the RFT.

## RFT EXPERIMENT LESSONS LEARNED

Based on development and experimentation with the RFT, the following observations and enhancements are noted.

The RFT ring seal power loss is a relatively small contributor to the overall transmission power loss. RFT power loss does not scale with system power, but is a function of diameter, speed, and pressure. RFT power loss increases when the overall transmission design power level requires larger diameter shafting, and in turn, larger ring seals, or when speed increases, or passage pressure differential increases.

The RFT and overall transmission power loss can be reduced by designing any components supplied through the RFT with low operating pressures (e.g., clutch release, or application pressure).

The RFT in the two-speed transmission used ring seals that were standard commercial products as well as the installation geometry. Due to different operating conditions, future design should include a detailed design optimization with respect to operating temperatures and geometry.

The RFT rotor outer diameter can be optimized to increase net area in contact with the face side of the ring seal to reduce the effective contact pressure, thereby reducing wear, and improving seal life.

The RFT rotor ring seal width should be widened slightly to ensure that pressure fluid is at the inside diameter of the ring seal and is applied radially outward to the RFT stator.

The RFT power loss at nominal 80 psi differential pressure is found to be low and can be a reasonable option to supply lubrication at nominal 80 psi internal to a rotating system within a housing where seals are not required to be leak free.



Low wear, high-speed, ring seals such as those made from polyimide material performed well for the experimental time accumulated.

## RVLT TECHNICAL CHALLENGE

### Transmission Power Loss Technical Challenge

Configuration 1: OCG/DC was selected to scale a 1000 HP rated design using analytical and experimental data and access the power losses associated with bearings, gear meshes, RFT, overrunning sprag, and windage. RFT power loss experiments and overrunning sprag power loss optimization experiments support the above. The exercise verified a RVLT program milestone technical challenge, that a two-speed design, combined with lightweight components, can provide a 50% speed change with less than 2% power loss and with no increase in weight. A comparison of total power losses for all three transmissions is shown below in the upper portion of Figure 23.

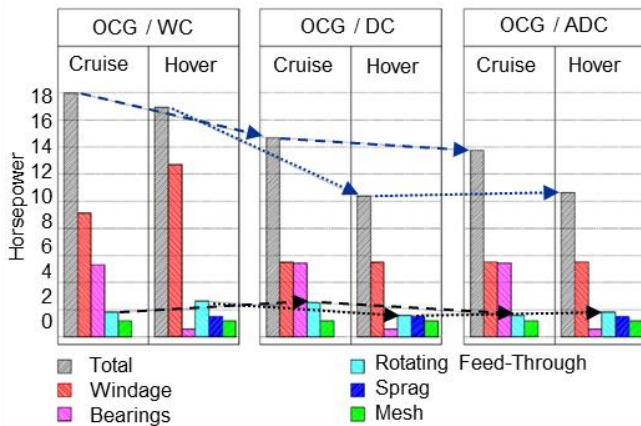

**Figure 23. Relative power loss comparison Configurations 1, 3, and 4.**

It should be noted in the lower portion of Figure 23 that the RFT power losses are relatively small and decreased from 2.5 hp to 1.6 hp during cruise and increases from 1.6 hp to 1.8 hp during hover comparing the OCG/DC and OCG/ADC configurations. This is due to reduced clutch operating pressure resulting from increased annular piston area and the more strategic reversed operating scheme, where clutch engagement is released during cruise and is pressurized during hover.

## POTENTIAL RFT ENHANCEMENT

In addition to reducing clutch operating pressure, potential improvements in RFT performance can be obtained with lower sliding speed. Design speed is usually a fixed requirement. Ring seals employed in the GRC two-speed transmission test articles and variable-speed concepts

operate at speeds near, or higher than, recommended. To take advantage of potential improvements through reduced sliding speed, a concept was conceived that reduced the surface sliding speed at the ring seals while maintaining machine speed. The concept introduces an intermediate rotor sleeve, located between the original rotor sleeve and stator sleeve, separated by ring seals. This doubles the number of required ring seals but can reduce the tangential sliding rubbing speed by nearly 40% for the given RFT. The intermediate rotor is supported on bearings and operates at speed below the machine design speed, thereby creating a reduced relative speed at the ring seals. Within the overall budget for this transmission project, the concept was not pursued since seal life was not a near term concern and was thought as research for others working in seals. The concept is presented in Appendix B.

## OVERRUNNING SPRAG POWER LOSS

The sprag clutch is the other component common to all of the GRC two-speed transmissions. The sprag clutch overruns during hover 1:1 mode and is engaged during cruise 2:1 mode. A paper describing experiments and results for power-loss associated with a continuously overrunning sprag clutch during hover mode is planned for later this year in a corresponding paper to be titled “*Two-Speed Rotorcraft Research Transmission Power-Loss Associated with a Continuously Overrunning Sprag Clutch*”.

## CONCLUDING REMARKS

This paper has summarized the results of isolated experiments for a RFT design feature that employs simple ring seals and is a key component in the array of inline concentric two-speed transmissions designed, manufactured, and tested at GRC for advanced high-speed rotorcraft.

Lessons learned from the design and experiments with the RFT in the two-speed transmission test hardware can be used to guide and aid in the design of an intermediate power version and may be applicable to other designs using similar components.

## REFERENCES

1. Johnson, W. and Yamauchi, G.K., Watts, M.E., “NASA Heavy Lift Study,” NASA/TP-2005-213467, 2005.
2. Kish, J., “Vertical Lift Drive System Concept Studies Variable Speed/Two-Speed Transmissions”, NASA/CR—2002-211564, ARL—CR—495, 2002.
3. Bossler, R.B. Jr., “Vertical Lift Drive System Concepts Studies,” NASA/CR—2002-211563, 2002.
4. Stevens, M.A., Lewicki, D.G., and Handschuh, R.F., “Variable/Multispeed Rotorcraft Drive System Concepts”, NASA/TM-215456, ARL-TR-4758, 2009.
5. Stevens, M.A., Lewicki, D.G., and Handschuh, R.F., “Concepts for Variable/Multi-Speed Rotorcraft Drive System”, American Helicopter Society 64<sup>th</sup> Annual Forum Proceedings, Montreal, Canada, April 2008, NASA/TM-215276, ARL-TR-4562, 2008.
6. Snyder, C.A., “Defining Gas Turbine Engine Performance Requirements for the Large Civil TiltRotor (LCTR2), NASA/TM-2013-218101.
7. Stevens, M.A., Lewicki, D.G., and Handschuh, R.F., “Concepts for Multi-Speed Rotorcraft Drive System - Status of Design and Testing at NASA GRC”, American Helicopter Society 71<sup>st</sup> Annual Forum Proceedings, Virginia Beach, Virginia USA, May 2015.
8. Lewicki D.G. and Stevens, M.A., “Testing of Two-Speed Transmission Configurations for use in Rotorcraft”, NASA/TM-2015-218816, June 2015.
9. Sekiguchi, S., Suzuki, H., Van Ryper, R.G., and Ritchey, D.J., “Development of a new high performance material to improve vehicle efficiency by reducing frictional and parasitic energy losses in transmission components”, Internet:  
[http://www2.dupont.com/Vespel/en\\_US/assets/downloads/vespel\\_s/Vespel2515WhitePaperVan\\_Ryper\\_Sekiguchi.pdf](http://www2.dupont.com/Vespel/en_US/assets/downloads/vespel_s/Vespel2515WhitePaperVan_Ryper_Sekiguchi.pdf)

## APPENDICES

A - Transmission Configurations

B - Reduced Speed Dual Ring Seal Rotating Feed-Through (RSDRS-RFT) and Ring Seal Operation

## APPENDIX A

### Transmission Configurations

The rotating assemblies for four of six possible two-speed transmission configurations are shown. The remaining two configurations are possibilities that were not tested.

Configuration	Figure
1: OCG / Dry-Clutch,	A1
2: DSI / Dry-Clutch,	A2
3 OCG / Wet-Clutch.	A3
4: OCG / Alternate-Dry Clutch	A4

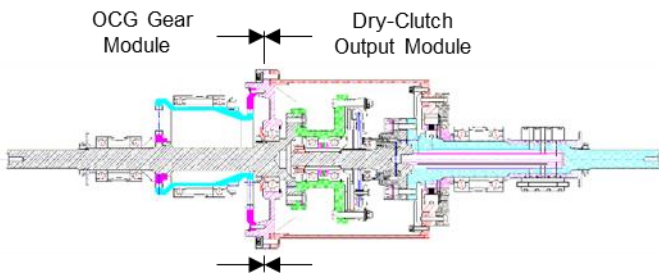

**Figure A1. Configuration 1: OCG Gear / Dry-Clutch**

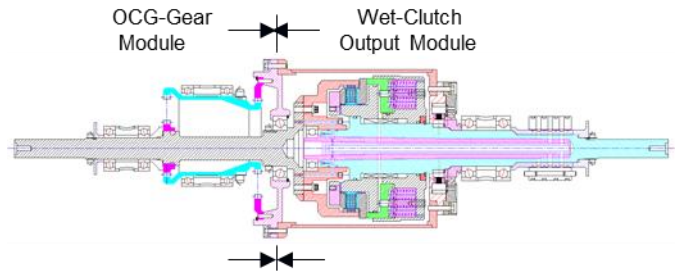

**Figure A3. Configuration 3: OCG Gear / Wet-Clutch.**

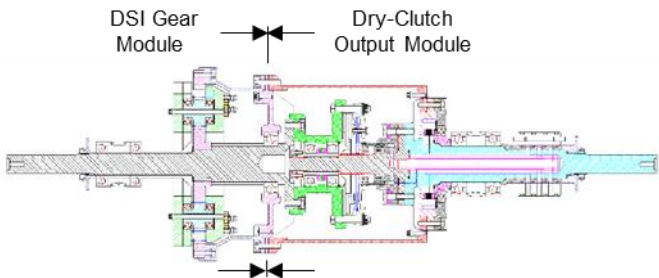

**Figure A2. Configuration 2: DSI Planetary / Dry-Clutch**

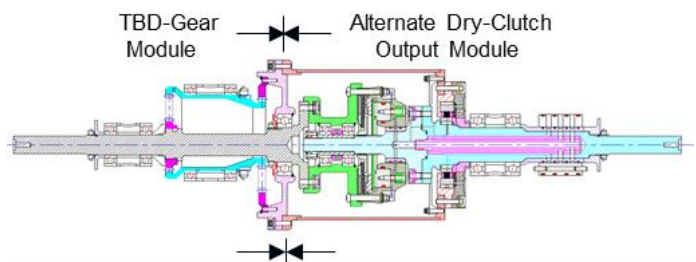

**Figure A4. Configuration 4: OCG / Alternate Dry-Clutch**

## APPENDIX B

### Reduced Speed Dual Ring Seal Rotating Feed-Through (RSDRS-RFT) and Ring Seal Operation

Throughout design and test of various configurations of the GRC two-speed drive, lowering clutch operating pressure has been a focus to minimize power loss at the RFT. In the initial commercial dry-clutch used in Configuration 1, OCG/DC control pressure was lowered by altering the clutch and removing one of two diaphragm disc springs, thereby reducing clamping (driving) pressure 50%. Required release pressure was also high due to the small cross section area piston approximately one square inch in the hydraulic release bearing (HRB). In designing the wet-clutch, as well as during the design of the alternate dry-clutch, pressure area of the annular pistons was significantly increased as there was no mechanical advantage present as in the diaphragm disc spring used in the original dry-clutch. During design evolution, the required hydraulic pressure was reduced twice by a factor of two. Within geometry constraints pressure reduction was exploited to the extent possible.

To further improve the ring seal operating conditions and move toward the lower left of the graph previously presented in Figure 15, the remaining avenue to consider is tangential sliding speed at the ring seal side face. The objective of reducing the tangential speed at the ring seal is both increasing seal life as well as possibly extending the operating speed of the shaft. For the two-speed transmission design, improving service life is the goal since the shaft speed is a design constraint. The concept conceived has the potential to reduce tangential speed at the ring seal to 60% of the shaft speed, moving the operating points to the left in Figure 15. Conversely, machine output shaft speed could be increased by nearly 167% if the operating point(s) were close to the “not recommended” side of a respective curve.

Lowering tangential speed at the ring seal, was considered but not designed nor tested. The concept was developed to the level to test either independently, as in the subject ring seal component set-up, or to be incorporated as an integral feature to the existing RFT to test with any of the GRC two-speed transmissions.

The basis of the RSDRS-RFT concept introduces a second, intermediate, rotor sleeve in between the shaft mounted rotor sleeve and the static stator sleeve in the RFT support, where the intermediate rotor sleeve, larger in diameter is rotated at some lower intermediate speed. The above, establishes a relative differential speed between the inner rotor and the intermediate rotor, and between the intermediate rotor and the stator. Rotating the intermediate rotor at a speed such that both the inner and outer relative tangential differential speeds are equal will maximize the sliding speed reduction. Within the above all seal rings see the same pressure differentials and sliding speeds. The required intermediate speed can be achieved with a gear drive of the appropriate ratio. The concept is shown below in Figure B1.

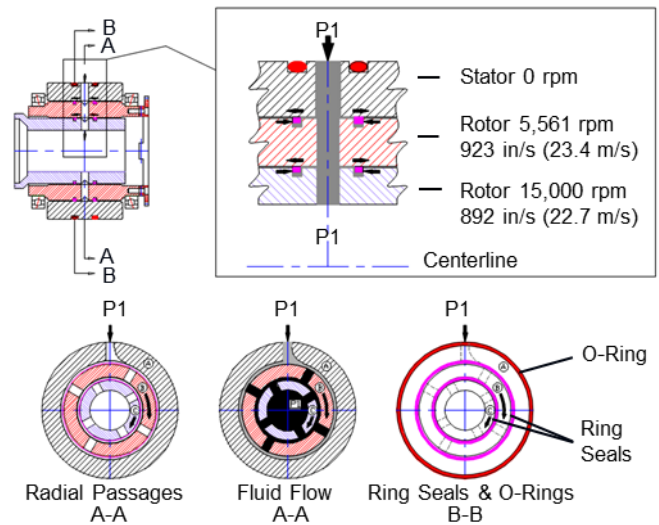

**Figure B1. RSDRS-RFT Fluid Flow**

The intermediate rotor drive is shown in Figures B2 and B3.

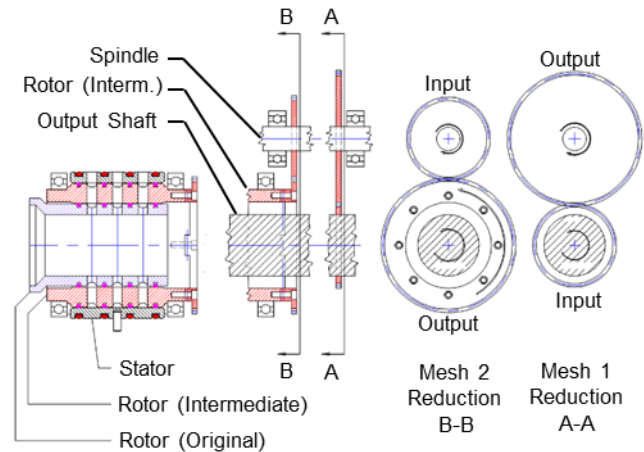

**Figure B2. RSDRS-RFT Mechanical Drive**

Integration of the RS-DRS RFT into the existing RFT used in the GRC two speed drive is shown below in Figure B3.

Rotating Feed-Through RSDRS Integrated Into Two-Speed Drive

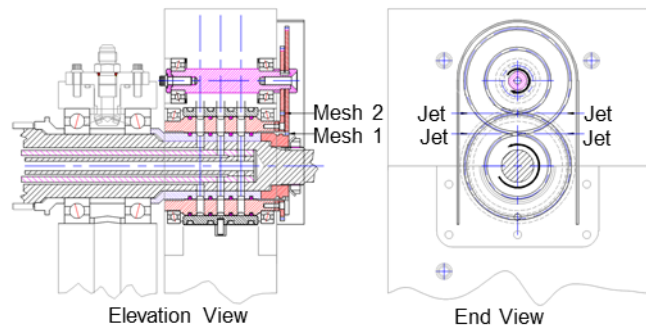

**Figure B3. RSDRS-RFT in Two-Speed Drive**





