



US010078036B1

(12) **United States Patent**  
**Agui et al.**

(10) **Patent No.:** **US 10,078,036 B1**  
(45) **Date of Patent:** **Sep. 18, 2018**

(54) **SYSTEM AND APPARATUS FOR FILTERING PARTICLES**

(71) Applicant: **The United States of America as represented by the Administrator of the National Aeronautics and Space Administration**, Washington, DC (US)

(72) Inventors: **Juan H. Agui**, Strongsville, OH (US); **Rajagopal Vijayakumar**, Liverpool, NY (US)

(73) Assignee: **The United States of America as Represented by the Administrator of National Aeronautics and Space Administration**, Washington, DC (US)

(\*) Notice: Subject to any disclaimer, the term of this patent is extended or adjusted under 35 U.S.C. 154(b) by 13 days.

(21) Appl. No.: **14/816,624**

(22) Filed: **Aug. 3, 2015**

#### Related U.S. Application Data

(63) Continuation of application No. 13/527,181, filed on Jun. 19, 2012, now Pat. No. 9,121,792.

(51) **Int. Cl.**  
**G01N 1/22** (2006.01)  
**G01N 15/02** (2006.01)

(52) **U.S. Cl.**  
CPC ... **G01N 1/2208** (2013.01); **G01N 2001/2223** (2013.01); **G01N 2015/0261** (2013.01)

(58) **Field of Classification Search**  
CPC ..... **G01N 1/2208**; **G01N 2001/2223**; **G01N 2015/0261**

See application file for complete search history.

(56) **References Cited**

#### U.S. PATENT DOCUMENTS

5,906,752 A *	5/1999	Williams	.....	B01D 46/22
				210/400
2002/0122177 A1 *	9/2002	Sioutas	.....	G01G 17/04
				356/336
2005/0028616 A1 *	2/2005	Marple	.....	G01N 1/2208
				73/863.22
2010/0242632 A1 *	9/2010	Call	.....	B07B 7/00
				73/863.22

#### FOREIGN PATENT DOCUMENTS

AU 236619 \* 5/1960

#### OTHER PUBLICATIONS

Agui, Juan H., Vijayakumar, Rajagopal, title "Development of an Indexing Media Filtration System for Long Duration Space Missions", American Institute of Aeronautics and Astronautics, 2013, USA.

\* cited by examiner

*Primary Examiner* — Son Le

*Assistant Examiner* — David Z Huang

(74) *Attorney, Agent, or Firm* — Robert H. Earp, III; William M. Johnson

(57) **ABSTRACT**

A modular pre-filtration apparatus may be beneficial to extend the life of a filter. The apparatus may include an impactor that can collect a first set of particles in the air, and a scroll filter that can collect a second set of particles in the air. A filter may follow the pre-filtration apparatus, thus causing the life of the filter to be increased.

**15 Claims, 11 Drawing Sheets**

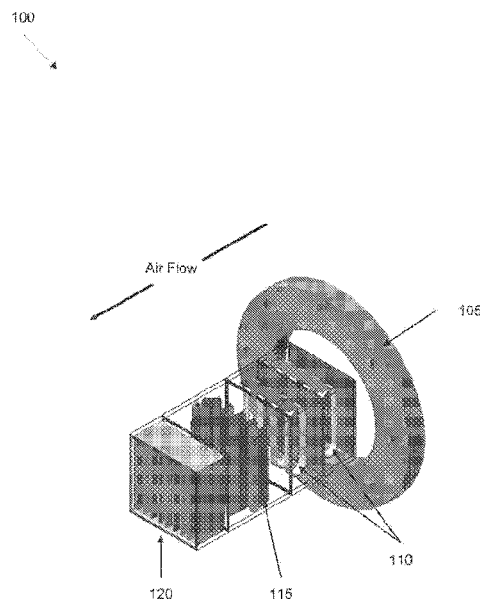

FIG. 1A

100

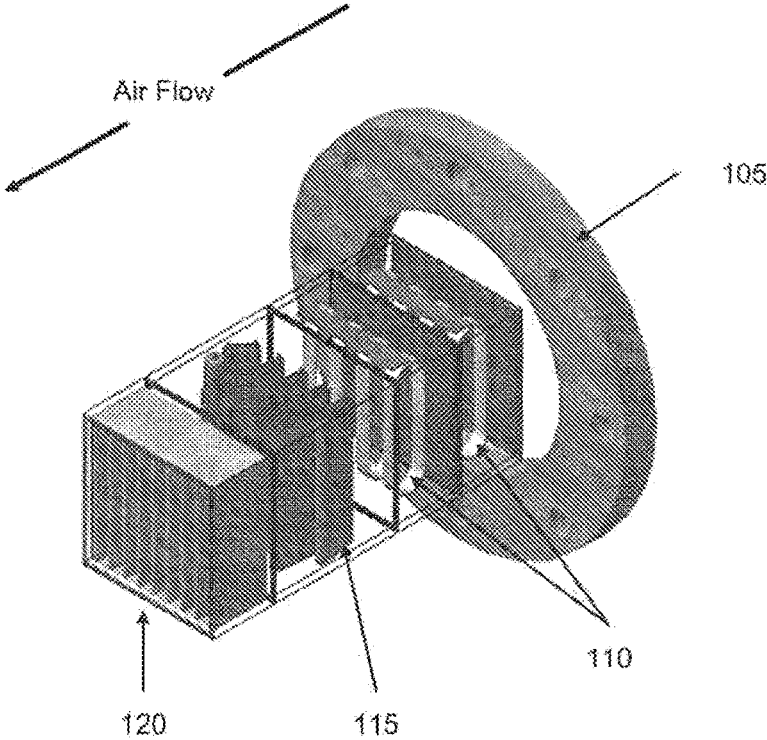

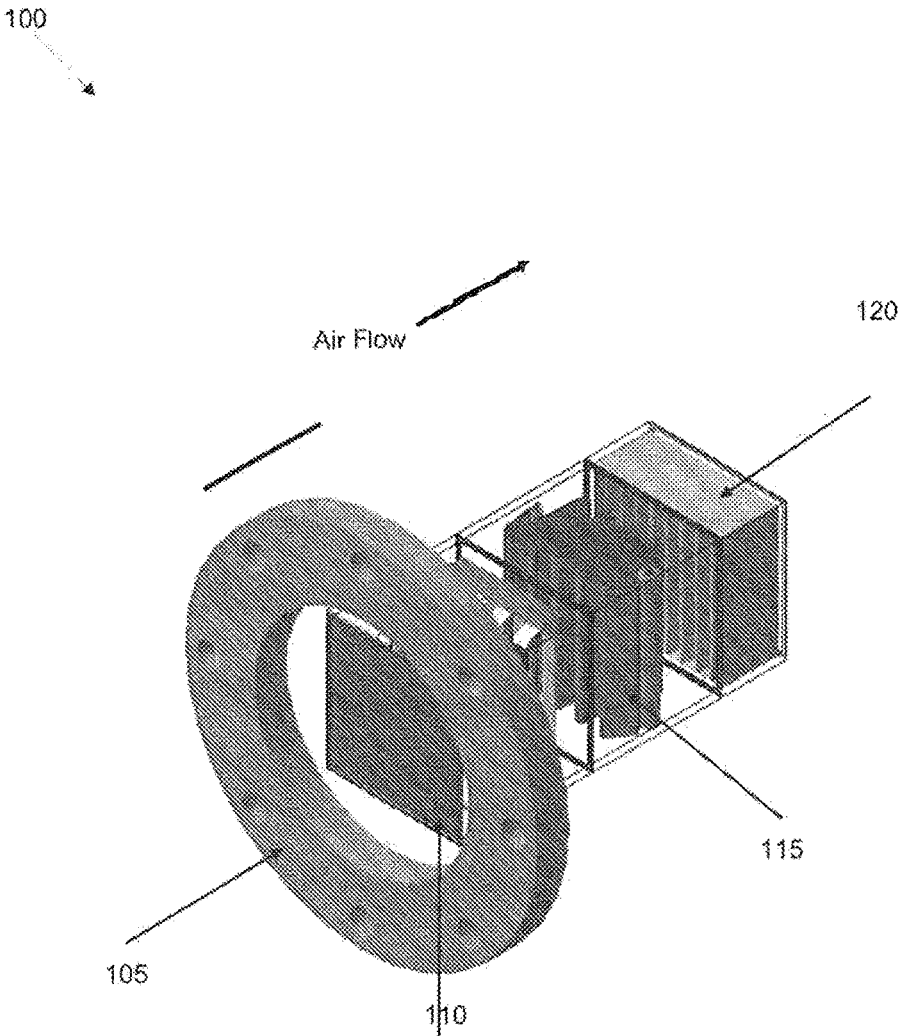

FIG. 1B



200  
↙

FIG. 2

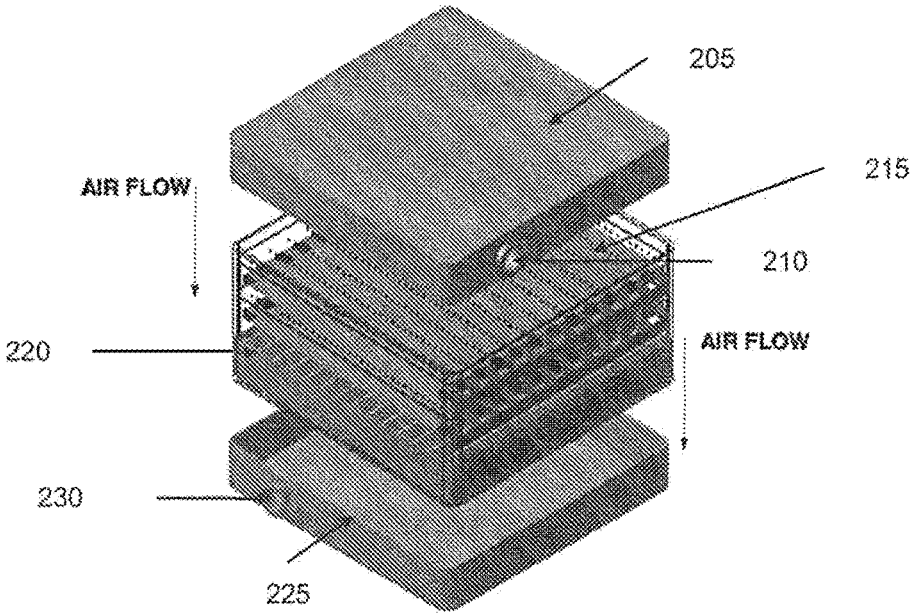
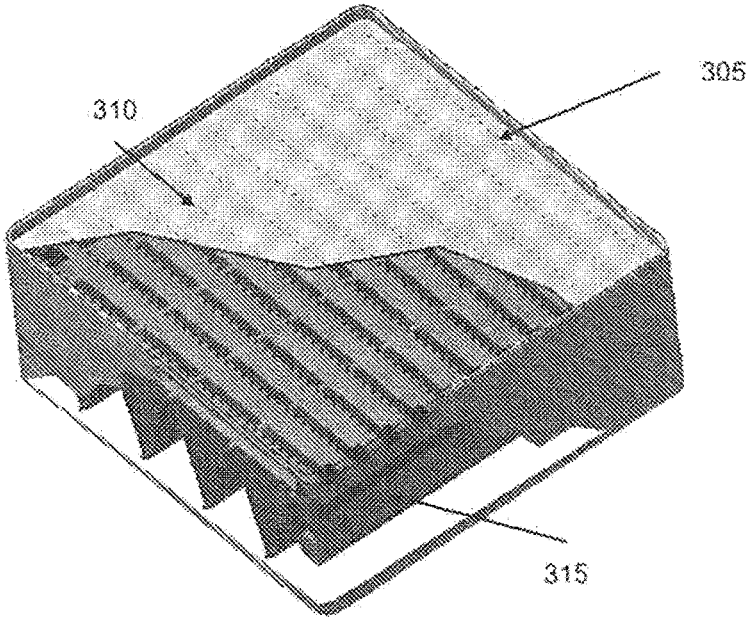

FIG. 3

300  
↙



400  
↘

FIG. 4

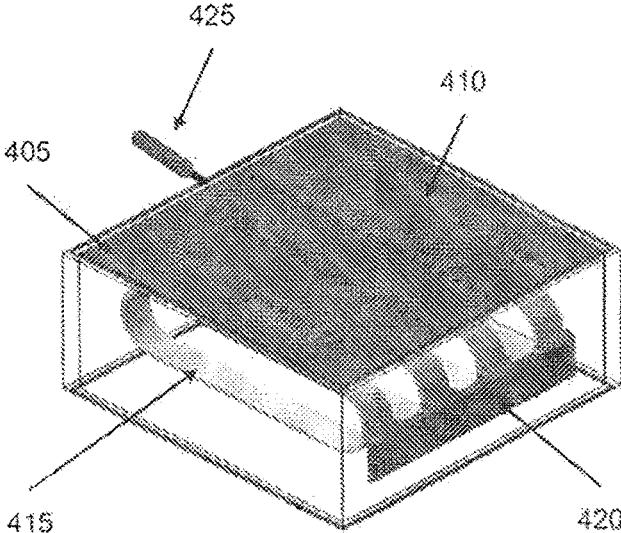

500  
↙

# FIG. 5

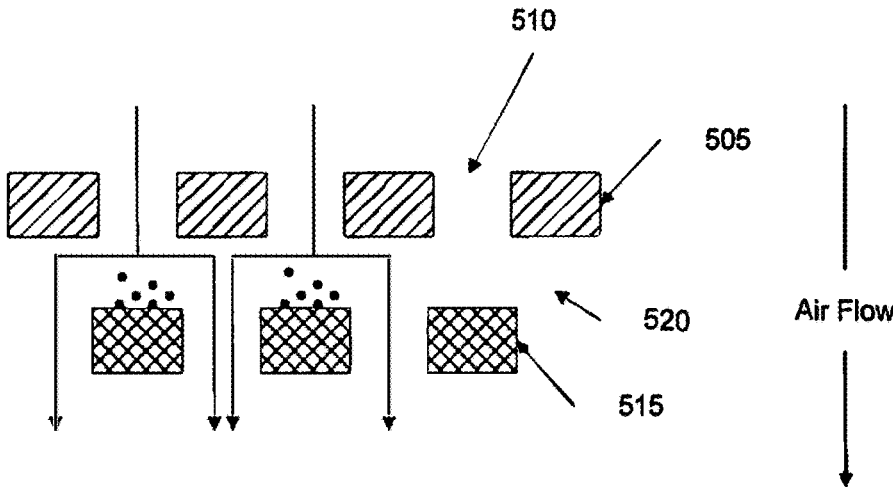

600  
↙

# FIG. 6

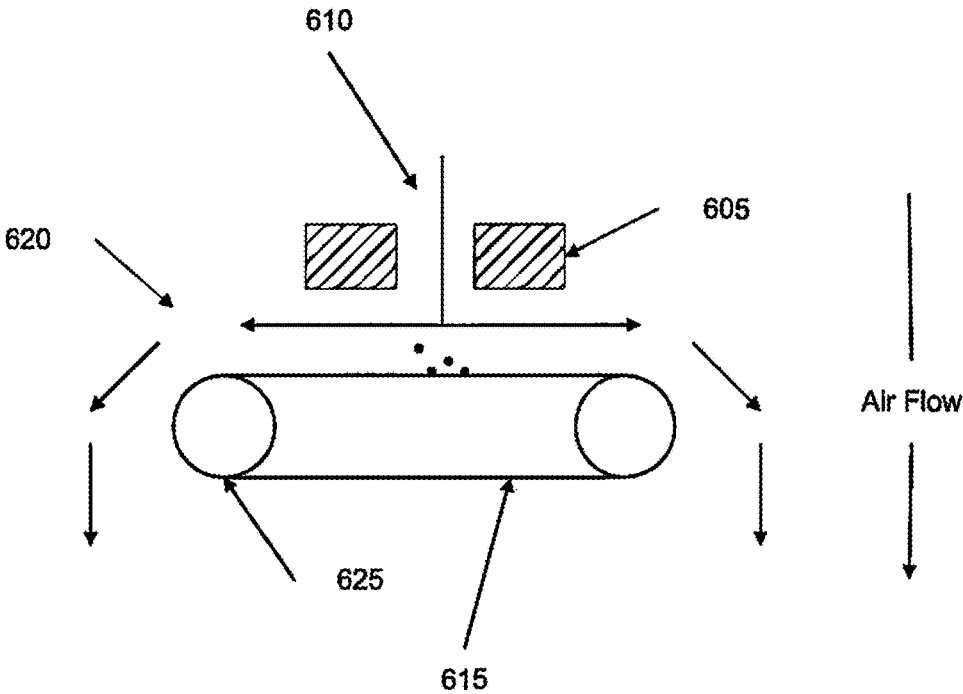



700  
↙

FIG. 7

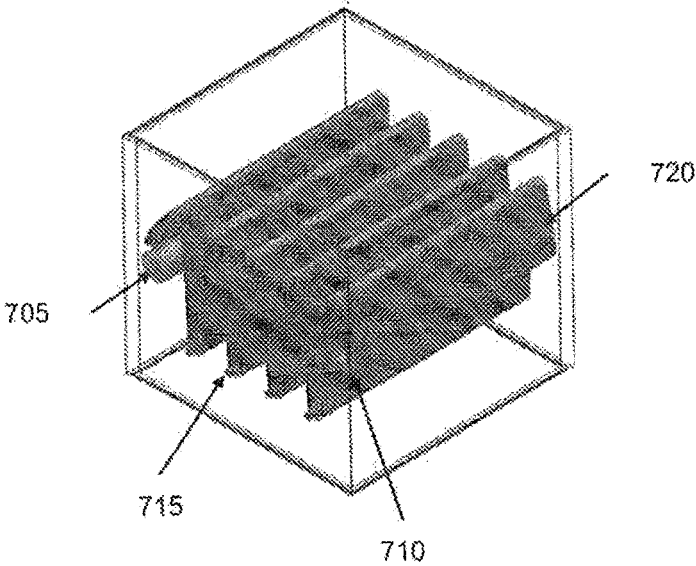

FIG. 8

800  
↙

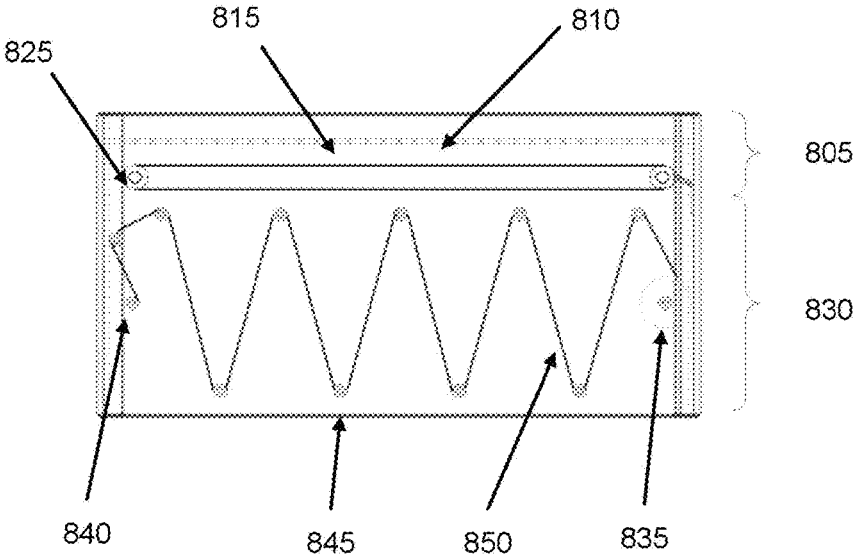

FIG. 9

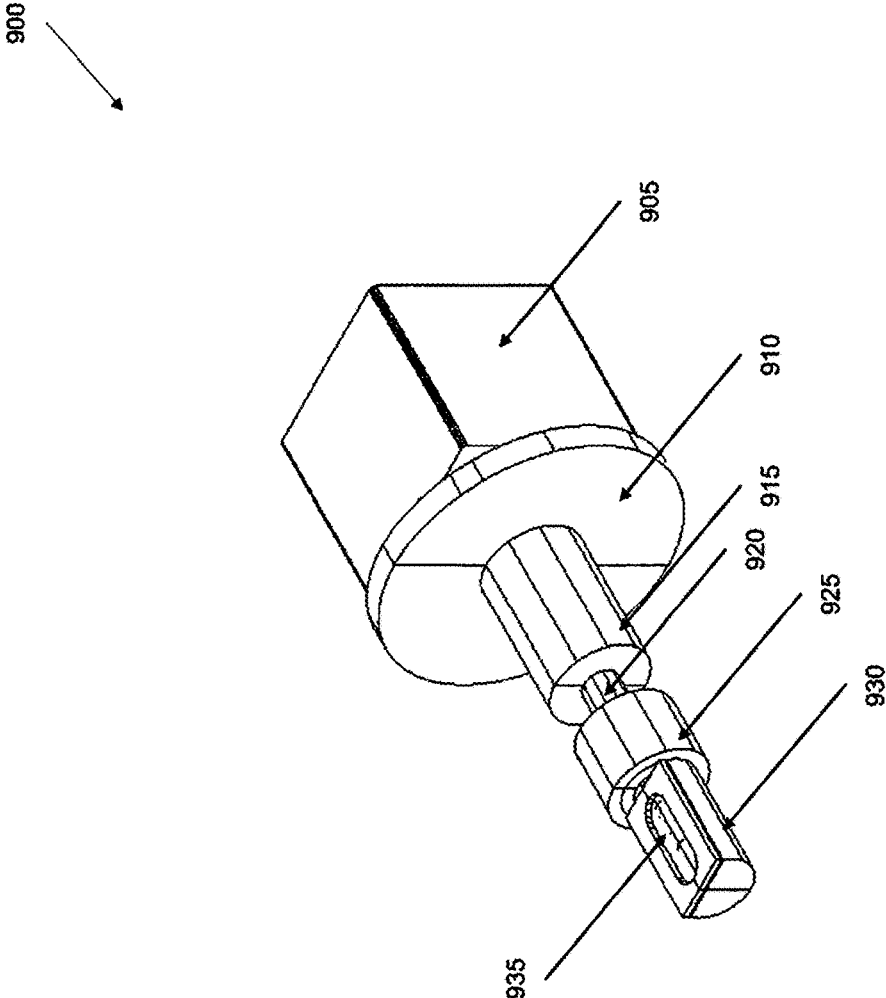
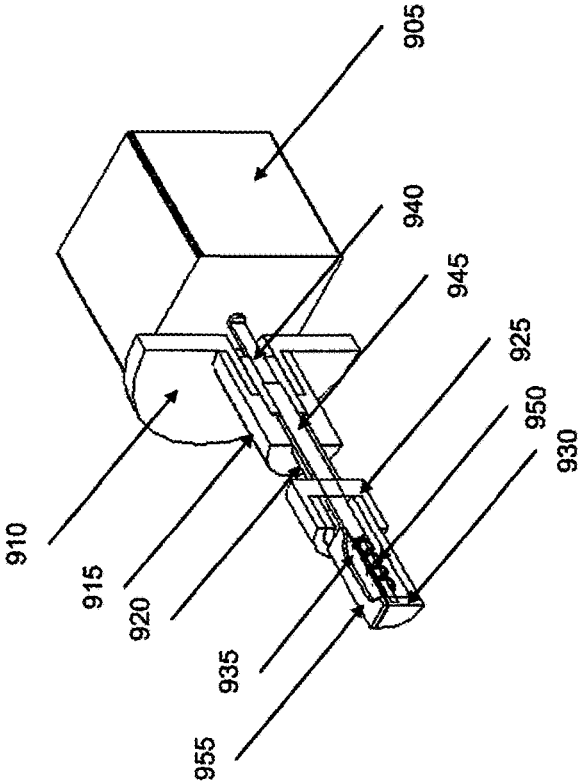

FIG. 10

1000



1

## SYSTEM AND APPARATUS FOR FILTERING PARTICLES

### CROSS-REFERENCE TO RELATED APPLICATION

This application is a continuation of U.S. patent application Ser. No. 13/527,181, entitled "A System and Apparatus for Filtering Particles", filed on Jun. 19, 2012, now U.S. Pat. No. 9,121,792.

### ORIGIN OF THE INVENTION

The invention described herein was made in the performance of work under a NASA contract and is subject to the provisions of Section 305 of the National Aeronautics and Space Act of 1958, Public Law 85-568 (72 Stat. 435; 42 U.S.C. 2457).

### FIELD

The present invention relates to a filtration device, and more particularly, to an impactor and filter system configured to capture a plurality of particles.

### BACKGROUND

During long duration human space flights in space crafts, human habitation in extraterrestrial habitats, such as the International Space Station, and in terrestrial applications such as commercial aircrafts, remote instrument enclosures, or a submarine, clean air is required for occupants such as astronauts, equipment, passengers or submarine crew. Maintaining cleanliness of the air requires filtration systems that have a long working life and are designed to filter several decades of different particle sizes. When a large dust load and a wide range of particle sizes are to be removed, it is a common commercial practice to use a multi-stage filtration system with a first stage that removes the largest particles. Since the largest fraction of dust in the air stream reduces the life of a filter, a pre-filter for large particles may be beneficial to protect the more expensive or critical filters designed for higher efficiencies and smaller particles.

However, the biggest challenge for long duration deployment is the difficulty of maintenance during service. For example, maintaining of the filter may be limited based on limited availability of the crew, crew time, and/or resources. Another challenge is to limit the footprint and payload while still providing the flexibility needed for the system to be tailored to the filtration needs of any mission or commercial application. Current space or commercial filtration devices do not provide a multi-year life or a small payload required for space.

### SUMMARY

Certain embodiments of the present invention may provide solutions to the problems and needs in the art that have not yet been fully identified, appreciated, or solved by current filtration devices. For example, certain embodiments of the present invention are directed to a filter system that includes a pre-filter stage to protect the more expensive or critical and higher efficiency stages of the filter system. The pre-filter stage increases the life of the filter system.

In one embodiment, an apparatus includes an impactor plate and a plurality of bands. The impactor plate includes a plurality of orifices that allow air to traverse through the

2

plurality of orifices. Each band is located near the impactor plate, and is configured to collect particles in the air.

In another embodiment, an apparatus includes a supply spool and a receiving spool. The supply spool is configured to unwind material over a plurality of rollers and the receiving spool can wind the material. The material is configured to collect particles, as air traverses through the apparatus.

In yet another embodiment, an apparatus includes an impactor and a scroll filter. The impactor is configured to collect a first set of particles in the air, and the scroll filter is configured to collect a second set of particles in the air.

### BRIEF DESCRIPTION OF THE DRAWINGS

For a proper understanding of the invention, reference should be made to the accompanying figures. These figures depict only some embodiments of the invention and are not limiting of the scope of the invention. Regarding the figures:

FIGS. 1A and 1B illustrate a first view and a second view of a multi-stage filter, according to an embodiment of the present invention.

FIG. 2 illustrates a multi-stage filter, according to an embodiment of the present invention.

FIG. 3 illustrates a top-view of the multi-stage filter shown in FIG. 2, according to an embodiment of the present invention.

FIG. 4 illustrates an impactor, according to an embodiment of the present invention.

FIG. 5 illustrates a front view of a cross-section of the impactor shown in FIG. 4, according to an embodiment of the present invention.

FIG. 6 illustrates a side view of a cross-section of the impactor shown in FIG. 4, according to an embodiment of the present invention.

FIG. 7 illustrates a scroll filter, according to an embodiment of the present invention.

FIG. 8 illustrates a cross-section of a first stage impactor and a scroll filter, according to an embodiment of the present invention.

FIG. 9 illustrates a particle generator, according to an embodiment of the present invention.

FIG. 10 illustrates a cross-section of the particle generator shown in FIG. 9, according to an embodiment of the present invention.

### DETAILED DESCRIPTION OF THE EMBODIMENTS

Embodiments of the present invention provide an apparatus configured to capture particles of different sizes utilizing one or more impactors and/or scroll filters. FIGS. 1A and 1B illustrate a first view and a second view of a multi-stage filter 100, according to an embodiment of the present invention. In this embodiment, multi-stage filter 100 is shown for open flow purposes without an inlet and outlet manifold, and may be used to efficiently filter both larger and smaller particles, thus increasing the life of, for example, a high-efficiency particulate arresting (HEPA) filter 120. Multi-stage filter 100 in this embodiment includes, for example, a mounting flange 105, two impactors 110, a scroll filter 115, and HEPA filter 120. It should be appreciated that certain embodiments may include one or more impactor stages 110 and/or one or more scroll filters 115 as pre-filtration devices. Impactors 110 and scroll filter 115 may act as a pre-filtration device prior to air flowing into, for example, HEPA filter 120. Furthermore, the size of impac-

tors **110** and scroll filter **115** may be scalable to any size, or the material may be changed in scroll filter **115**, as would be appreciated by a person of ordinary skill in the art. For example, the size of impactors **110** and scroll filter **115** may be scaled for residential, commercial, or industrial purposes, as well as spaceflight purposes, and as such, all embodiments are not limited to use in space. In another example, the quality of the material in scroll filter **115** may be changed depending on the efficiency desired in multi-stage filter **100**.

FIG. 2 illustrates a multi-stage filter **200**, according to an embodiment of the present invention. Multi-stage filter **200** may be used as a pre-filtration device. For example, air may flow through inlet **210** of a first cover plate (or manifold) **205**, and may flow through two stages of impactors **215**, as well as a scroll filter **220**. As will be discussed in greater detail below, impactors **215** and scroll filter **220** may be configured to capture or collect different sizes of particles as air traverses through multi-stage filter **200**. For example, impactors **215** may capture larger particles, and scroll filter **220** may capture smaller or nano particles. As impactors **215** and scroll filter **220** capture particles, the air may exit through outlet **230** of a second cover plate **225** and then flow to a filtering device, such as a HEPA filter or any other filtration device. Such a multi-stage pre-filtration device may improve the longevity of, for example, the HEPA filter.

FIG. 3 illustrates a top-view **300** of multi-stage filter **200** shown in FIG. 2, according to an embodiment of the present invention. Top-view **300** shows an impactor **305** containing a plurality of orifices **310**, such as holes or slits, to capture larger particles. While this embodiment depicts a plurality of holes **310**, impactor **305** may contain rectangular slits instead. It should be appreciated that the shape and size of the orifices or slits is a matter of design choice. Top-view **300** also shows a scroll filter **315** configured to capture smaller sized particles. It should be appreciated that the arrangement of the impactors and scroll filters shown in FIGS. 1-3 may be implementation-specific, or configured in any arrangement that would be appreciated by a person of ordinary skill in the art.

FIG. 4 illustrates an impactor **400**, according to an embodiment of the present invention. Impactor **400** includes an impactor plate **405** containing a plurality of orifices **410**. Depending on the size and shape of the particles that are to be removed, the size of orifices **410** may be increased or decreased in situ. In some embodiment, impactor plate **405** may include an adjusting unit **425**. Adjusting unit **425** may be configured to adjust the size and shape of plurality of orifice **410** in situ for performance changes in impactor **400**. For example, adjusting unit **425** may change the size or shape of the holes, slits, or any opening on impactor plate **405** at any time during operation of impactor **400**. While impactor plate **405** includes a plurality of holes in this embodiment, impactor plate **405** may include rectangular slits, triangular slits, or any opening as would be appreciated by a person of ordinary skill in the art to capture larger and/or smaller sized particles.

A gap (not shown) exists between impactor plate **405** and a plurality of collector belts **415**. The gap, as more clearly shown in FIG. 5, allows air to traverse through orifices **410** while larger sized particles are captured on each collector belt **415**. Collector belts **415** may be located beneath orifices **410** to allow maximum collection of particles. Depending on the size of the gap and/or orifices, different sizes of particles can be captured by collector belts **415**. While FIG. 4 shows four collector belts, other embodiments may include more or less than four collector belts.

Each collector belt **415** may be a rolling band of material, otherwise called an endless collector belt. To increase the life of each collector belt **415** and to minimize particles that are bound to each collector belt **415**, the material of each collector belt **415** may be made of porous material, or any material, to collect particles in the depth of collector belt **415** rather than the surface, thereby eliminating the need for tackifiers. Each collector belt **415** may be driven by a servo (not shown) that moves each collector belt **415** in either a left or right direction when particle buildup is detected.

Collector belt **415** may include individual and endless bands of material in one embodiment, and in another embodiment, may include individual bands that may be wound and unwound utilizing a plurality of rollers similar to the embodiment shown in FIG. 7. In certain embodiments, however, collector belt **415** may include bands that are connected together in a sheet of material, i.e., a sheet with alternate bands of solid material to collect particles and open mesh material for air to pass through similar to a patterned lace. In yet another embodiment, collector belt **415** may include a sheet that may be endless or wound and unwound. A person of ordinary skill in the art will readily appreciate that collector belt **415** may include different embodiments or combination of embodiments as discussed herein.

In conventional systems, each time a collector plate is filled up with particles, the collector plate is replaced or the entire system is replaced. This not only increases cost of maintaining the system, but also produces an inefficient operation of the system and reduces effective duty life between clean up. In this embodiment, rather than replacing each collector belt **415** when particle buildup occurs, each collector belt **415** may be indexed and dust scraper **420** may scrape particles from each collector belt **415** in order to allow each collector belt **415** to be used again. In certain embodiments, collector belts **415** with particle buildup may be indexed, while other collector belts **415** without particle buildup may remain unindexed. The scraped particles can then be taken to a lab, for example, for analysis purposes. The possibility of removing the collected particles for analysis purposes may offer the potential for investigating the history of the particles collected, and as a result, may be used to refine the design of filtration systems in space habitats, space crafts or commercial applications.

It should be appreciated that impactor **400** may also include a sensor (not shown) to detect when particle buildup occurs on collector belt **415** and, when such buildup occurs, the sensor may transmit a signal to a servo to rotate each collector belt **415** to allow scraper **420** to remove the particle buildup from each collector belt **415**. In certain embodiments, the sensor may detect that particle buildup has occurred based on the weight mass, inertia, or other means exerted by the particles on collector belts **415**, or based on detection method that would be appreciated by a person of ordinary skill in the art. Such a configuration reduces the cost of replacing impactor **400** each time particle buildup occurs, as well as improves the longevity and efficiency of impactor **400**. This configuration may also prevent particle rebounding from occurring, since collector belts **415** are cleaned after a particle buildup occurs and/or after a predetermined period of time.

In addition to virtually permanent filtration, impactor **400** can be tailored to meet any pre-filtration requirement. For example, it should be appreciated that impactor **400** may be stackable, as depicted in FIG. 1. By stacking a plurality of impactors **400** in series, particles of different sizes may be removed more efficiently. In certain embodiments, impactor plate **405** having a plurality of orifices **410** may be inter-

5

changed or swapped with another impactor plate having larger or smaller sized orifices, depending on the size of the particle that is targeted. The size and/or material of collector belts **415** may also change accordingly.

FIG. **5** illustrates a front view of a cross-section **500** of impactor **400** shown in FIG. **4**, according to an embodiment of the present invention. Cross-section **500** shows particles in the air traversing through a plurality of orifices **510** of an impactor plate **505**. Gap **520** between impactor plate **505** and collector belts **515** allows the air to flow through impactor **500**, while each collector belt **515** captures particles. By placing each collector belt **515** just beneath orifices **510** of impactor plate **505**, air is forced to bend around each collector belt **515** and exit to the next filter, while each collector belt **515** captures particles of different sizes.

FIG. **6** illustrates a side view of a cross-section **600** of impactor **400** shown in FIG. **4**, according to an embodiment of the present invention. Cross-section **600** shows particles in the air being captured by a collector belt **615** as the particles traverse through an orifice **610** of impactor plate **605**. The air flows through gap **620** and down to the next filter. Cross-section **600** also depicts a roller (or servo) **625** that allows collector belt **615** to rotate and be cleaned by the scraper depicted in FIG. **4**. As the particles are removed from collector belt **615**, a collection mechanism (not shown) may be used to collect the particles from collector belt **615**. This allows the scraped particles to be taken to a lab, for example, for analysis purposes.

FIG. **7** illustrates a scroll filter **700**, according to an embodiment of the present invention. Scroll filter **700** may be modular, such that a plurality of scroll filters can be stacked, or can be placed after or before one or more impactors. For example, an impactor set at thirty percent efficiency may be in front of a first scroll filter set at ninety percent efficiency followed by a second scroll filter set at ninety percent efficiency.

In this embodiment, a supply spool **705** includes material (or particle collector) **720**, and a take up (or receiving) spool **710** is configured to receive material **720** when particle buildup is detected. A plurality of rollers **715** are used in this embodiment to move material **720** from supply spool **705** to receiving spool **710**. It should be appreciated that each roller **715** may be connected via belt and/or pulley (not shown) for positive drive of material **720**.

While this embodiment shows material **720** zigzagging over plurality of rollers **715**, plurality of rollers **715** may be placed in any manner appreciated by a person of ordinary skill in the art, such that material **720** may move towards receiving spool **710** when particle buildup occurs. For instance, plurality of rollers **715** may be adjusted by mounting each roller **715** on slots in a housing (not shown), thus enabling changes in performance of scroll filter **700**. When appropriately configured, it may be possible to make such changes in situ, thereby providing a measure of control over the filter performance to meet actual filtration needs of a mission.

Depending on the space between each roller **715**, particles of different sizes may be captured by material **720**. Also, the number of rollers **715** that are used may vary based on the size of scroll filter **715** and the size of the particles to be captured. Furthermore, any suitable material, e.g., industrial, commercial, etc., may be used to capture particles. For example, a high efficiency or a low efficiency material may be used depending on the particles that are to be captured. In other words, filter performance can be adjusted by using different materials, as well as altering the geometry and/or spacing of each roller.

6

In some embodiments, material **720** may be driven by an external or internal servo (not shown). In one embodiment, the servo may rotate the receiving spool **710**, such that supply spool **705** may unwind a fresh set of material **702** each time a buildup of particles occurs on material **720**. In another embodiment, the servo may rotate each roller **715**, or any combination of supply spool **705**, receiving spool **710**, and rollers **715**, such that supply spool **705** may unwind a fresh set of material **720** each time a buildup of particles occurs on material **720**. In certain embodiments, one or more servos may rotate supply spool **705**, rollers **715**, and receiving spool **710**, or any combination thereof, each time particle buildup occurs. The buildup of particles may be detected by, for example, a sensor (not shown) that detects the buildup, or a certain amount of weight, mass, inertia, pressure, or other means, on material **720**. Upon detection, material **720** may be indexed and a fresh roll of material **720** may be released from supply spool **705** while material **720** including the particle buildup is received at receiving spool **710**. By receiving used material at receiving spool **710**, a collection history can be realized, such that one may determine what type of particles are collected and the efficiency rate of collection of the particles, as well as peak particle loading events over the period of operation. This not only enables improvements on the scroll filter device based on the collection history, but the possibility of removing the collected particles for analysis purposes may offer the potential for investigating the history of the particles collected, and as a result, may be used to refine the design of filtration systems in space habitats, space crafts, or commercial applications.

It should be appreciated that once all of material **720** is at receiving spool **710**, material **720** may be removed from scroll filter **700** and new material may be inserted at supply spool **705**. The new material may be unwound from supply spool **705**, such that new material may then begin capturing particles through the air. This configuration increases the longevity of scroll filter **700**, as well as any subsequent filter attached behind scroll filter **700**. Also, the cost to replace scroll filter **700** is reduced, since only material **720** is being replaced.

In an alternative embodiment, the used material may be cleaned, or otherwise treated, for reuse, thus reducing the payload for material **720** over long space flights. For example, as used material is received by receiving spool **710**, a scraper may be configured to remove the particle buildup such that the material can be reused. Such a configuration may provide an endless stream of material for continual use.

FIG. **8** illustrates a cross-section **800** of a first stage impactor **805** and a scroll filter **830**, according to an embodiment of the present invention. In this embodiment, as air flows through a plurality of orifices **810** in an impactor plate **805**, larger particles, for example, are collected by a plurality of collector belts **815**. Rollers **825** can rotate collector belts **815** when particle buildup occurs.

Smaller particles that are not collected by, for example, collector belts **815** may be collected by material **850**. As discussed in FIG. **7**, material **850** may be oriented in a zigzag manner across a plurality of rollers **845**. When particle buildup occurs, supply spool **835** can release unused material as the used material is wound up by receiving spool **840**. This configuration allows for a pre-filtration device to be formed, collecting both larger particles and smaller particles prior to entering, for example, a HEPA filter or any subsequent filter. Such a configuration increases the longevity of the subsequent filter.

In order to ensure that the above-described embodiments are fully functional, an in-situ particle generator may be used and operated in an air or gas closed system environment at non-standard or standard pressures. For example, FIG. 9 illustrates a particle generator 900, according to an embodiment of the present invention. Particle generator 900 includes a motor 905 that causes a drive shaft (not shown) to rotate a helical brush (also not shown) inside a particle sample cartridge 930. The rotation of the helical brush will be described in more detail below. It should be appreciated that while a helical brush is utilized in this embodiment, in other embodiments, different types of brushes or technology, such as a wiper, may be utilized that would achieve the same or a similar result of pushing particles through the screen of particle generator 900.

Particle sample cartridge 930 may be detachable and modular to allow particle samples of different sizes to be swapped. In other words, particle sample cartridge 930 may be swapped with another particle sample cartridge 930 containing different types of particles. Particle sample cartridge 930 may include a single type of particle, or multiple particles, depending on design choice. In some embodiments, particle sample cartridge 930 may include solid particle samples of different size, thus allowing impactors and scroll filters for different particle sizes to be tested. In other embodiments, particle sample cartridge 930 may include liquid based particles or a combination of solid and liquid based particles.

Particle generator 900 includes a mounting flange 910 and/or any sealing method or apparatus, as would be appreciated by a person of ordinary skill in the art, to mount and seal the internal cavity volume from the external environment. A first coupler 915 is used to couple, or hold together, the drive shaft, tube conduit 920, and the brush shaft. A second coupler 925 is used to couple, or hold together, the brush shaft and particle sample cartridge 930. Tube conduit 920 is used to protect the brush shaft from denigrating. When first and/or second couplers 915, 925 are removed, particle sample cartridge 930 can be removed or replaced with another particle sample cartridge.

FIG. 10 illustrates a cross-section 1000 of particle generator 900 shown in FIG. 9, according to an embodiment of the present invention. This embodiment shows a drive shaft 940 configured to drive brush shaft 945, thus causing a helical brush 950, for example, to rotate. For instance, motor 905 may cause helical brush 950 to rotate in alternating partial revolutions, such as a rocking motion, to drag particles back and forth across the length of screen 935. Based on the speed of rotation of helical brush 950, particles may be pushed through screen 935 at different rates. Screen 935 may be a mesh screen, or any type of screen that would be appreciated by a person of ordinary skill in the art. Also, the size of the mesh opening depends on the size of the particles that are being provided. The alternating motion prevents the particles from drifting towards a particular side of screen 935 or particle sample cartridge 930. This mode of operation can be sustained for a significant period of time for the duration of the test. To prevent screen 935 from moving, particle generator 900 also includes a flange 955 to hold screen 935 with particle sample cartridge 930.

Particles near screen 935 are continually pushed and ejected through screen 935 while the remainder of the particles move towards screen 935 due to settling and centrifugal effects from rotation. In certain embodiments, the face of screen 935 may be oriented or rotated relative to the flow direction to achieve optimal performance. For

example, screen 935 can be rotated at different angles, such that screen 935 can be facing down, up, sideways, or a combination thereof.

When particles start to deplete from particle sample cartridge 930, motor 905 may increase the rotational speed, or create a larger arc revolution, of helical brush 950 to push particles through screen 935. As particles are pushed through screen 935, the particles may enter a flow duct or facility for testing of a multi-stage filtration device. The particles in particle sample cartridge 930 may be dragged across the length of the internal cavity and on screen 935, thus pushing the particles through screen 935, allowing the particles to enter, for example, the flow duct described above.

In one embodiment, an apparatus for generating particles is provided. The apparatus includes a particle cartridge containing particles of different sizes. The apparatus also includes a drive shaft configured to drive a brush, such that the particles of different sizes are pushed through a screen and into a filtration device or pre-filtration device.

In another embodiment, the particle cartridge can be replaced with another particle cartridge. The particle cartridge may include particles of same size.

In yet another embodiment, the motor may cause the drive shaft to drive the brush in an alternating motion, such that the particles of different sizes are moved back and forth across a length of the screen and pushed through the screen.

In a further embodiment, the motor may cause the drive shaft to increase a speed of rotation, or create a larger arc revolution, for the brush, such that the particles of different sizes are ejected at the same or different rates through the screen when the particles of different size start to deplete in the particle cartridge.

In another embodiment, the motor may cause the drive shaft to increase or decrease the speed of rotation for the brush, such that the particles of different sizes are ejected through the screen at a faster or slower rate.

In some embodiments, the screen may include holes of different sizes depending on the size of particles contained within the particle cartridge.

In an alternative embodiment, the screen may be swapped with another screen based on the sizes of the particles contained within the particle cartridge.

In certain embodiments, a face of the screen may be oriented in different directions, to produce different flow and particle settling effects in order to tighten or spread the spatial distribution of particles in the flow and/or to achieve different particle generation rates.

In other embodiments, the apparatus for generating particles may include an aerodynamic element or turbulence generating element attached or designed into the outside body (on the upstream side of the body) of the particle cartridge, such that different particle spreading rates in the flow can be achieved. For example, the turbulence generator element may increase the turbulent mixing of the particles in the flow, and therefore, increase the spreading rate of the particles. The aerodynamic element, for example, may reduce or constraint the spreading of particles.

It will be readily understood that the components of the present invention, as generally described and illustrated in the figures herein, may be arranged and designed in a wide variety of different configurations. Thus, the detailed description of the embodiments of an apparatus and a system, as represented in the attached figures, is not intended to limit the scope of the invention as claimed, but is merely representative of selected embodiments of the invention.



The features, structures, or characteristics of the invention described throughout this specification may be combined in any suitable manner in one or more embodiments. For example, the usage of “certain embodiments,” “some embodiments,” or other similar language, throughout this specification refers to the fact that a particular feature, structure, or characteristic described in connection with the embodiment may be included in at least one embodiment of the present invention. Thus, appearances of the phrases “in certain embodiments,” “in some embodiments,” “in other embodiments,” or other similar language, throughout this specification do not necessarily all refer to the same group of embodiments, and the described features, structures, or characteristics may be combined in any suitable manner in one or more embodiments.

One having ordinary skill in the art will readily understand that the invention as discussed above may be practiced with steps in a different order, and/or with hardware elements in configurations which are different than those which are disclosed. Therefore, although the invention has been described based upon these preferred embodiments, it would be apparent to those of skill in the art that certain modifications, variations, and alternative constructions would be apparent, while remaining within the spirit and scope of the invention. In order to determine the metes and bounds of the invention, therefore, reference should be made to the appended claims.

We claim:

1. An apparatus, comprising:
    - an air flow including a first set of particles of varying sizes and a second set of particles of varying sizes;
    - an impactor configured to collect the first set of particles in the air flow as the air flow traverses through the impactor, wherein the impactor includes an impactor plate having a plurality of sets of orifices, wherein each set of orifices extends in a first direction; and
    - a scroll filter comprising:
      - a supply spool of a material, the material configured to collect the second set of particles;
      - a receiving spool connected to the supply spool via the material; and
      - at least one roller disposed between the supply spool and the receiving spool, wherein the material extends over the at least one roller such that the at least one roller defines a travel path for the material, wherein the at least one roller has a central axis extending in a second direction substantially perpendicular to the first direction;
- wherein the impactor further comprises a plurality of collector belts extending in the first direction spaced apart from the impactor plate and disposed between the impactor plate and the scroll filter, wherein the plurality of collector belts are configured to capture the first set of particles.

2. The apparatus of claim 1, wherein the first set of particles comprises one or more particles of varying sizes.
3. The apparatus of claim 1, wherein the second set of particles comprises one or more particles of varying sizes.
4. The apparatus of claim 1, wherein the first set of particles are larger in size than the second set of particles.
5. The apparatus of claim 1, wherein the first set of particles are smaller in size than the second set of particles.
6. The apparatus of claim 1, wherein the impactor is situated prior to, or after, the scroll filter, such that the first set and second set of particles are collected.
7. The apparatus of claim 1, further comprising:
  - one or more impactors prior to, or after the impactor, the scroll filter, or both.
8. The apparatus of claim 1, further comprising:
  - one or more scroll filters situated prior to, or after, the impactor, the scroll filter, or both.
9. The apparatus of claim 1, further comprising a servo mechanically coupled to the supply spool, the at least one roller, or the receiving spool, the servo configured to rotate to cause the material to translate over the roller towards the receiving spool.
10. The apparatus of claim 1, further comprising a servo mechanically coupled to the at least one roller, the servo configured to rotate to cause the material to translate over the roller towards the receiving spool.
11. The apparatus of claim 1 comprising a first roller and a second roller, wherein the first roller is disposed above a plane in which the supply and receiving spools are disposed and the second roller is disposed below the plane, wherein the material extends over an upper side of the first roller and a lower side of the second roller such that the material zig-zags between the supply spool and the receiving spool, wherein the plane in which the supply and receiving spools are disposed is substantially parallel to the impactor plate.
12. The apparatus of claim 11, further comprising a housing, the housing including a first slot coupled to the first roller and a second slot coupled to the second roller, wherein the positioning of the first and second rollers within the first and second slots is adjustable.
13. The apparatus of claim 1, further comprising a sensor configured to detect buildup of particles on the material.
14. The apparatus of claim 1, wherein the impactor further comprises a dust scraper disposed proximate to and in contact with the plurality of collector belts, wherein the dust scraper is configured to scrape captured particles from the plurality of collector belts upon movement of the plurality of collector belts.
15. The apparatus of claim 1, wherein the scroll filter includes a plurality of rollers disposed between the supply spool and the receiving spool, wherein successive ones of the plurality of rollers are spaced apart from one another based on sizes of the second set of particles.

\* \* \* \* \*