



NASA's Nuclear Thermal Propulsion (NTP) Project

***Mike Houts
Sonny Mitchell
Ken Aschenbrenner
Melissa Van Dyke
Harold Gerrish
Les Johnson***

NASA Marshall Space Flight Center



Nuclear Thermal Propulsion (NTP)

[STMD \(GCD\) Nuclear Thermal Propulsion Video](#)

<https://www.youtube.com/watch?feature=youtu.be&v=miy2mbs2zAQ&app=desktop>



Background: *NTP Benefits*

- For human Mars missions, NTP can reduce crew time away from earth from >900 days to <500 days while still allowing ample time for surface exploration
 - Reduce crew exposure to space radiation, microgravity, other hazards
- NTP can enable abort modes not available with other architectures
 - Potential to return to earth anytime within 3 months of earth departure burn, also to return immediately upon arrival at Mars
- Stage/habitat optimized for use with NTP could further reduce crew exposure to cosmic rays and provide shielding against any conceivable solar flare
- NTP can reduce cadence and total number of SLS launches
- NTP has potential for reducing cost, increasing flexibility, and enabling faster response times in cis-lunar space
- First generation NTP is a stepping stone to fission power systems and highly advanced nuclear propulsion systems that could further improve crew safety and architectural robustness



Why is NTP Attractive for Human Missions to Mars?

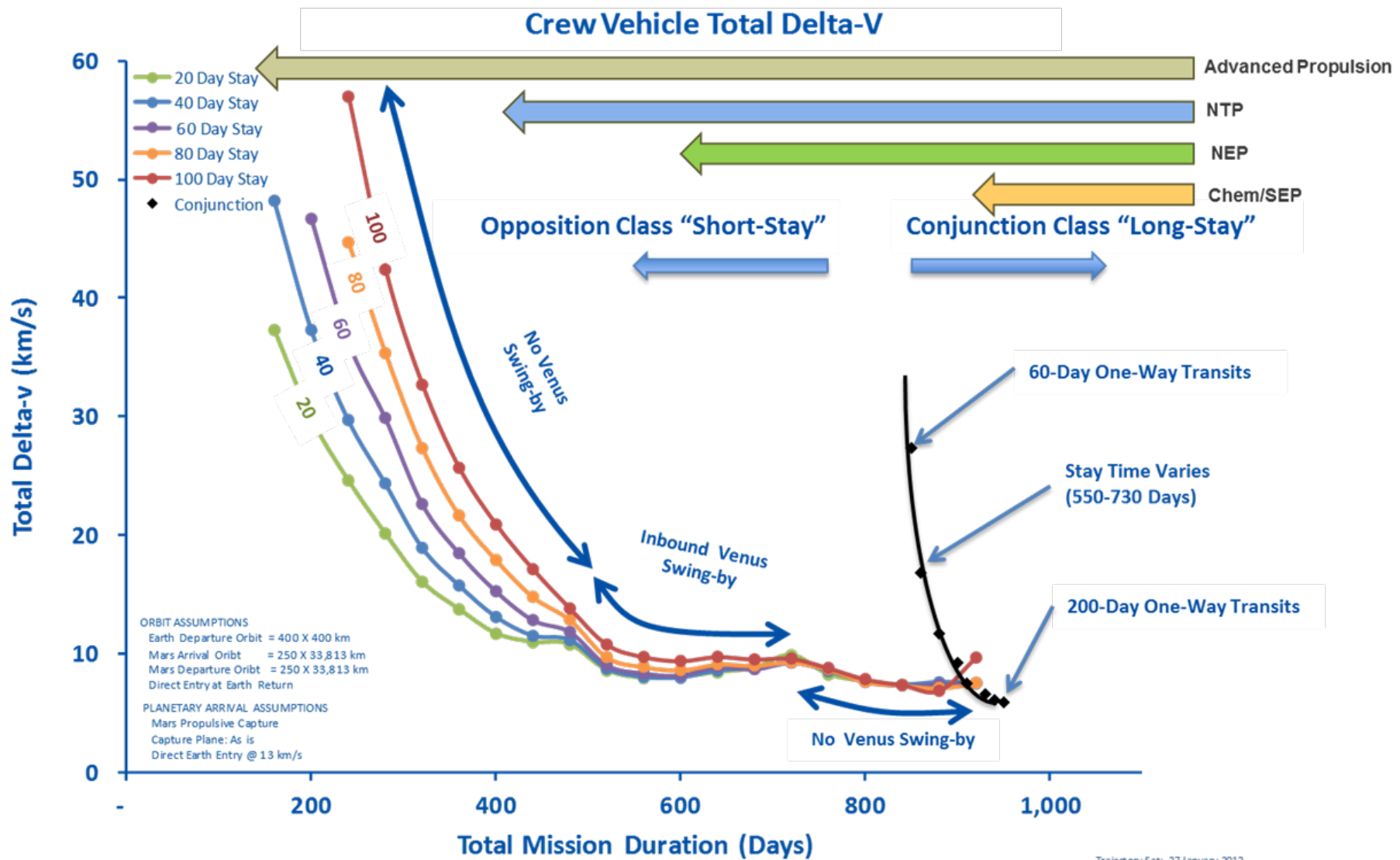



Basics of Nuclear Systems

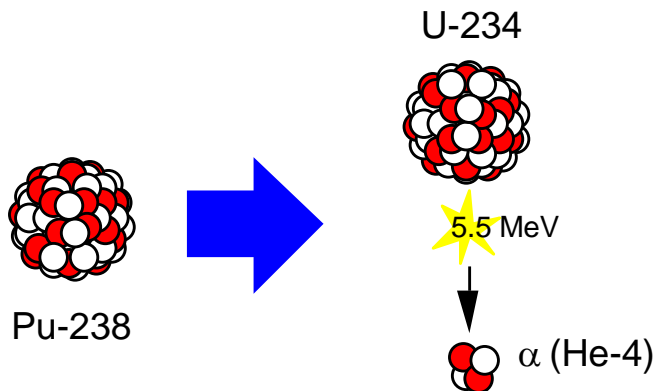

Heat Energy = 0.023 MeV/nucleon (0.558 W/g Pu-238)

Natural decay rate (87.7-year half-life)

Long history of use on Apollo and space science missions

44 RTGs and hundreds of RHUs launched by U.S. since the 1960s

Heat produced from natural alpha (α) particle decay of Plutonium (Pu-238)

Used for both thermal management and electricity production

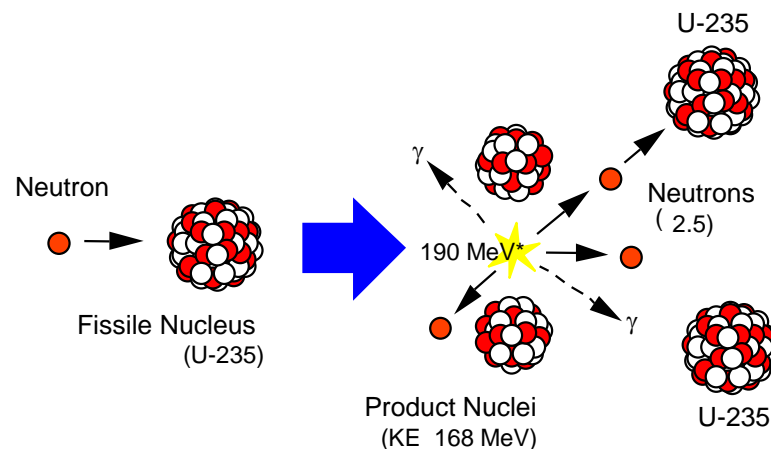

Heat Energy = 0.851 MeV/nucleon

Controllable reaction rate (variable power levels)

Used terrestrially for over 70 years

Fissioning 1 kg of uranium yields as much energy as burning 2,700,000 kg of coal

One US space reactor (SNAP-10A) flown (1965)

Former U.S.S.R. flew 33 space reactors

Heat produced from neutron-induced splitting of a nucleus (e.g. U-235)

At steady-state, 1 of the 2 to 3 neutrons released in the reaction causes a subsequent fission in a "chain reaction" process

Heat converted to electricity, or used directly to heat a propellant



20 NTP Engines Designed, Built, and Tested During the Rover/NERVA Program (1955-1973)

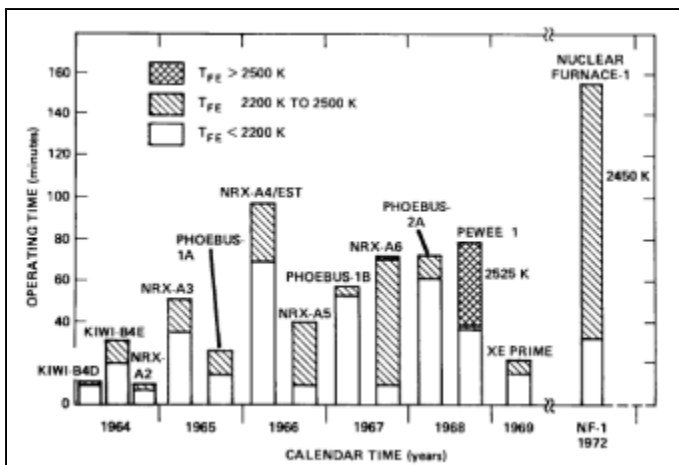
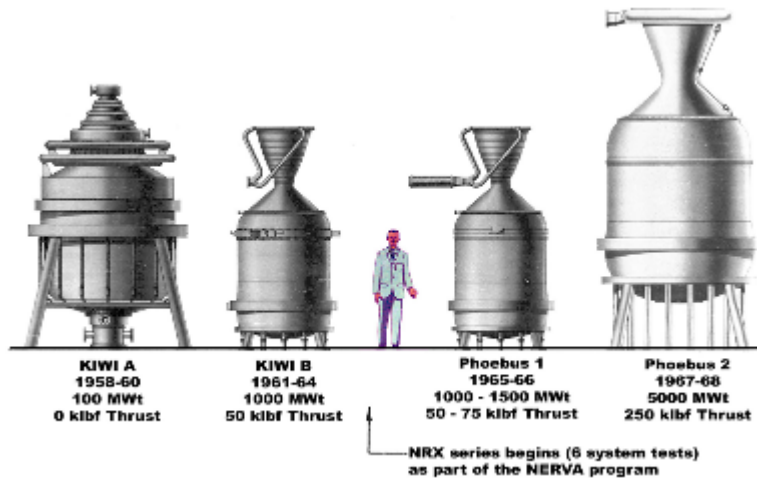
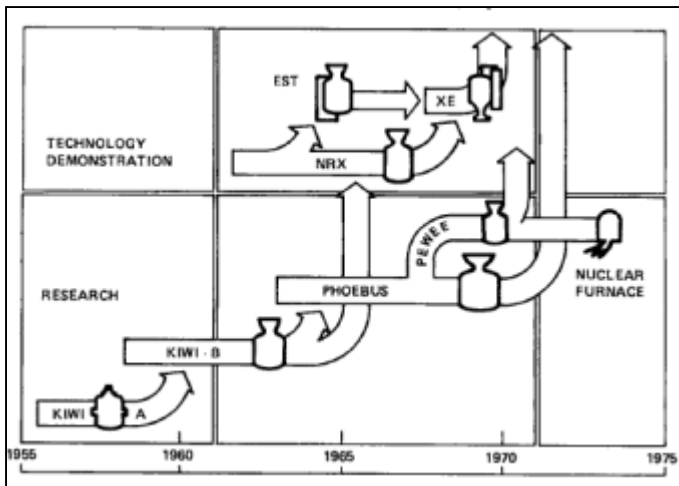



How Might Initial NTP Systems Work?

- Propellant heated directly by a nuclear reactor and thermally expanded/accelerated through a nozzle
- Low molecular weight propellant – typically Hydrogen
- Thrust directly related to thermal power of reactor: $100,000 \text{ N} \approx 450 \text{ MW}_{\text{th}}$ at 900 sec
- Specific Impulse directly related to exhaust temperature: 830 - 1000 sec (2300 - 3100K)
- Specific Impulse improvement over chemical rockets due to lower molecular weight of propellant (exhaust stream of O₂/H₂ engine actually runs hotter than NTP)

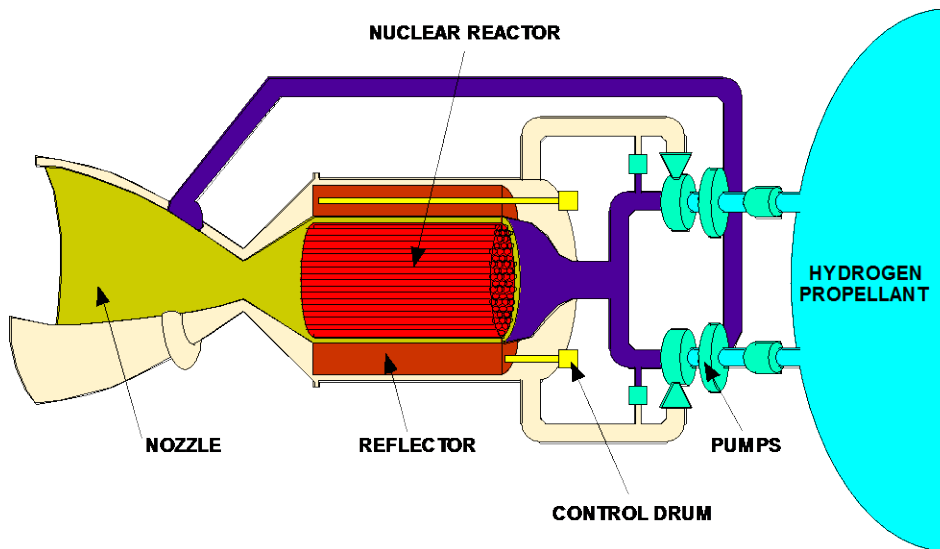

Major Elements of a Nuclear Thermal Rocket

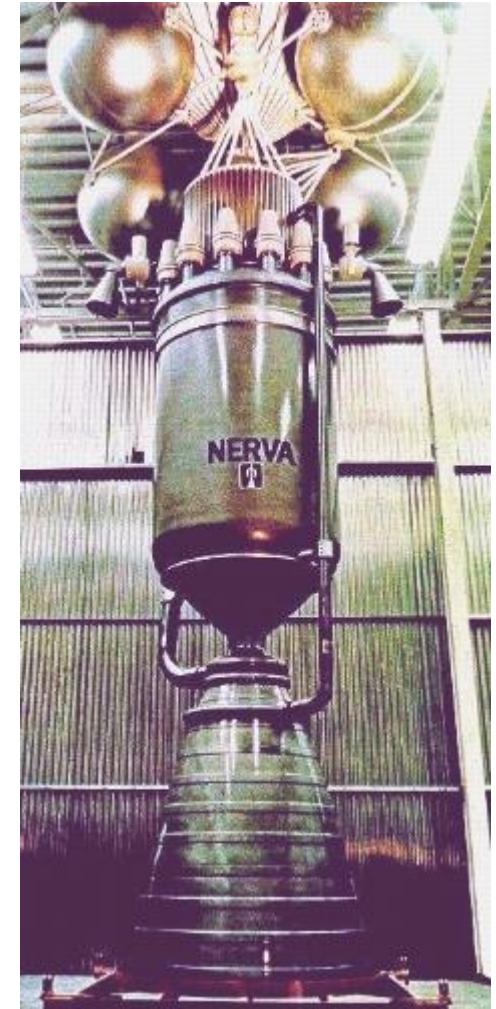

NERVA Nuclear Thermal Rocket Prototype

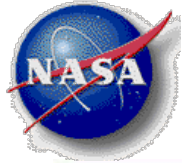

How Might Initial NTP Systems Work?

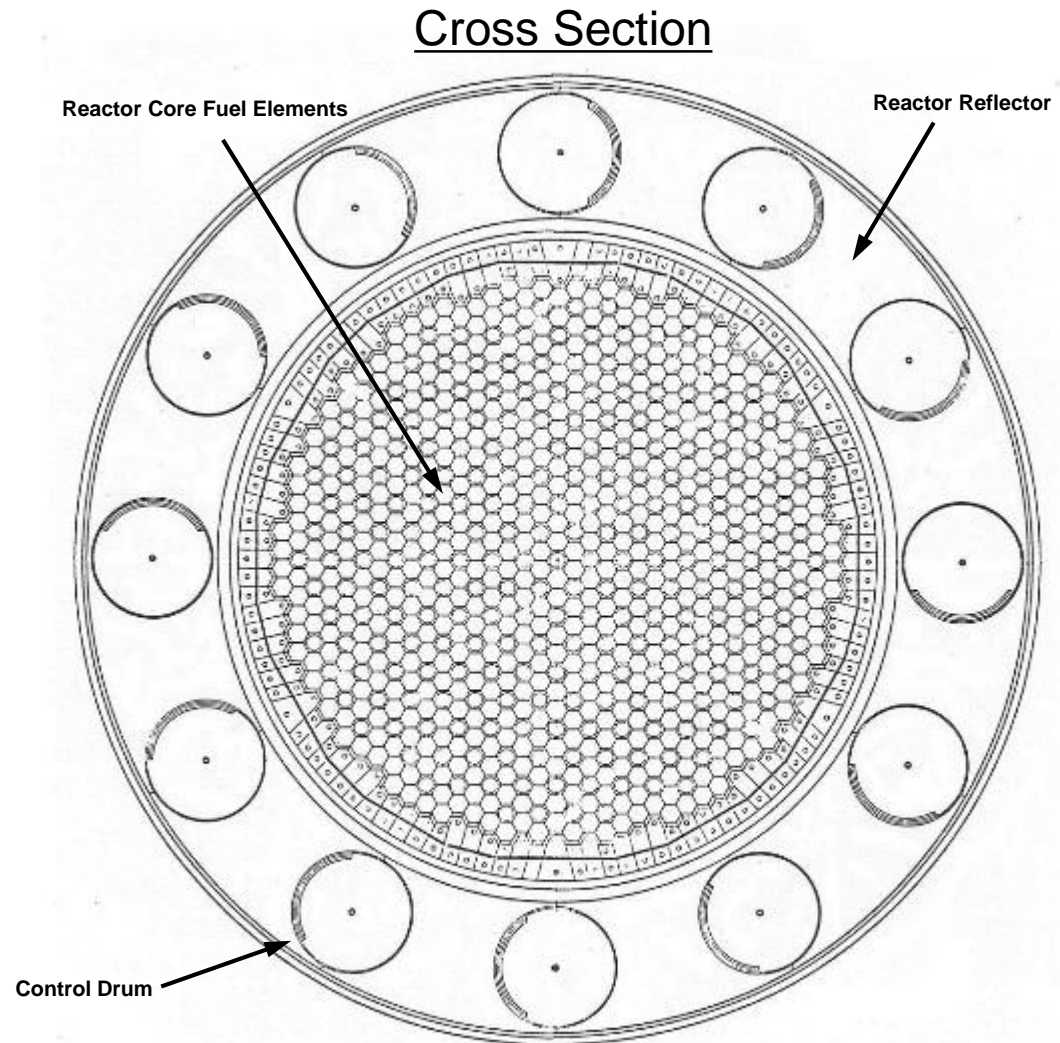
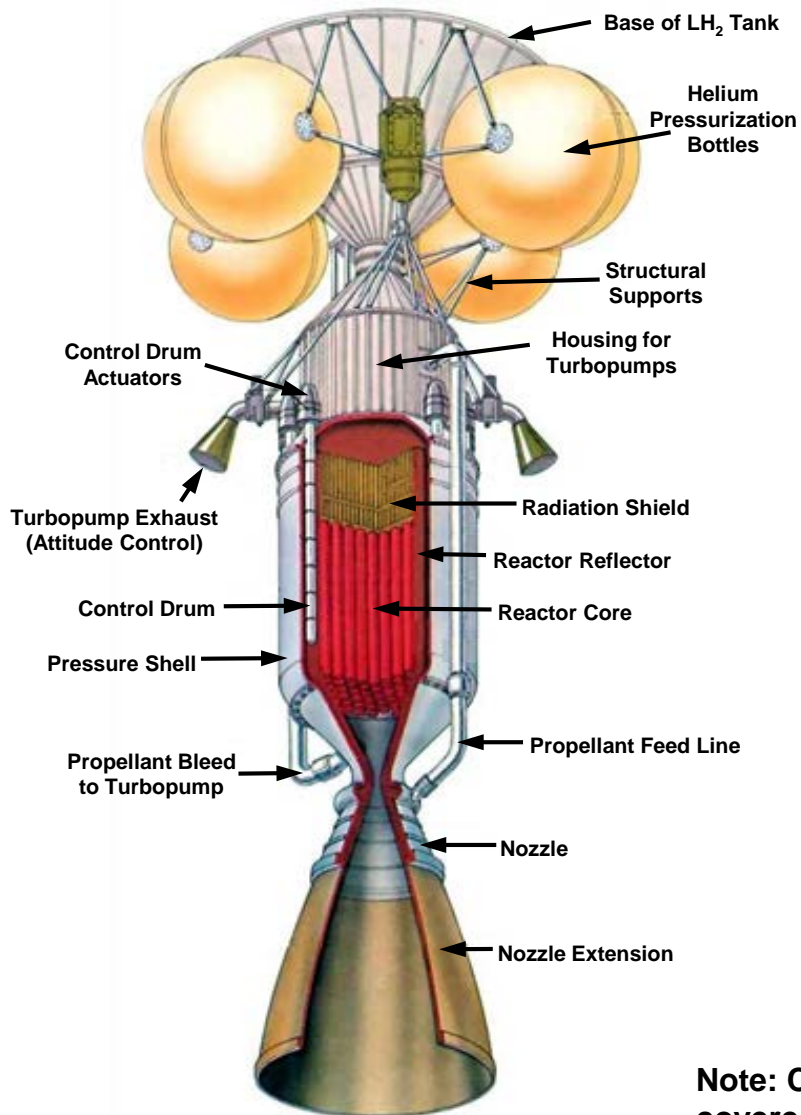

Note: Control drums rotate to control reactivity. Portion of circumference covered with neutron absorber and remainder is reflector.



Can NTP systems using Low-Enriched Uranium (LEU) be Developed?

- Directly reduce cost through savings related to safeguards and security
- Indirectly (and more significantly) reduced cost through enabling use of an optimal development approach and team
- Consistent with ongoing programs to convert operational Highly Enriched Uranium (HEU) systems to LEU
- Consistent with US policy. “The United States is committed to eliminating the use of HEU in all civilian applications, including in the production of medical radioisotopes, because of its direct significance for potential use in nuclear weapons, acts of nuclear terrorism, or other malevolent purposes.” (2012 White House “Fact Sheet”)

Initial LEU Conceptual Designs Very Promising



Evolving LEU Designs Have Significant Potential Advantages

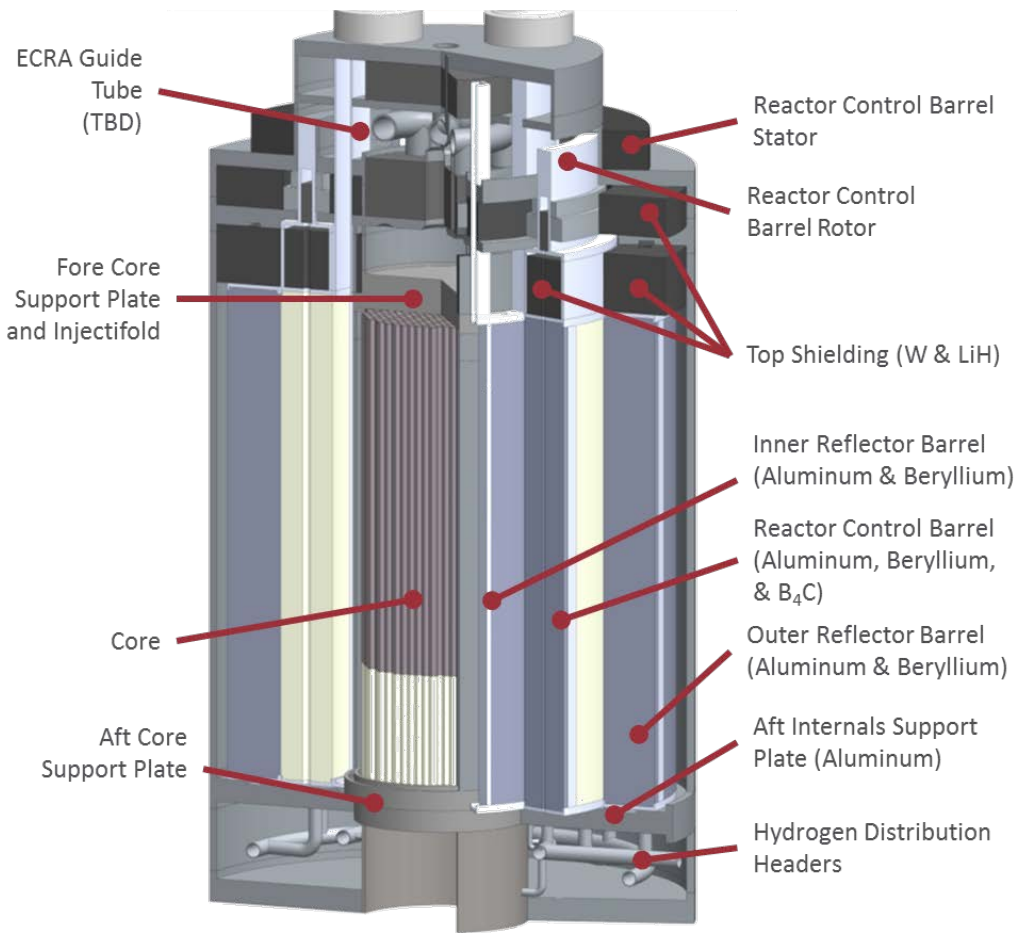

Courtesy BWXT

- Graded Mo to Mo/W approach reduces engine mass and need for W-184.
- Multiple potential cermet fuel fabrication options. Optimize for performance and affordability.
- Potential for dual-use core design. Optimize for NTP, but close derivatives potentially applicable to high performance space fission power systems.



LEU Fission System Considerations

- Greatly reduced safeguards considerations if LEU is used. US encourages use of LEU in nuclear programs around the world.
- No uniquely hazardous materials in fission systems prior to operation. LEU toxicity comparable to depleted uranium. Depleted uranium used in shielding for industrial radiography cameras, trim weights in aircraft (up to 1500 kg in Boeing 747-100), sailboat keels, ammunition, armor plating, etc. Beryllium used in most modern spacecraft. James Webb telescope contains ~300 lbs of beryllium.
- Primary potential hazard from space fission systems is inadvertent criticality while personnel are in very close proximity (i.e. ground processing). Highly affected radius is < 10 m. System design and procedures for precluding inadvertent criticality during ground processing can be made independent of launch vehicle specifics.
- For criticality (with significant fissions) to occur during a launch failure the system must remain geometrically intact while safety mechanisms are simultaneously removed. Designs to preclude this can be made independent of launch vehicle specifics.



NTP Ground Testing Exhaust Capture Concept

Total Containment NTP Exhaust System

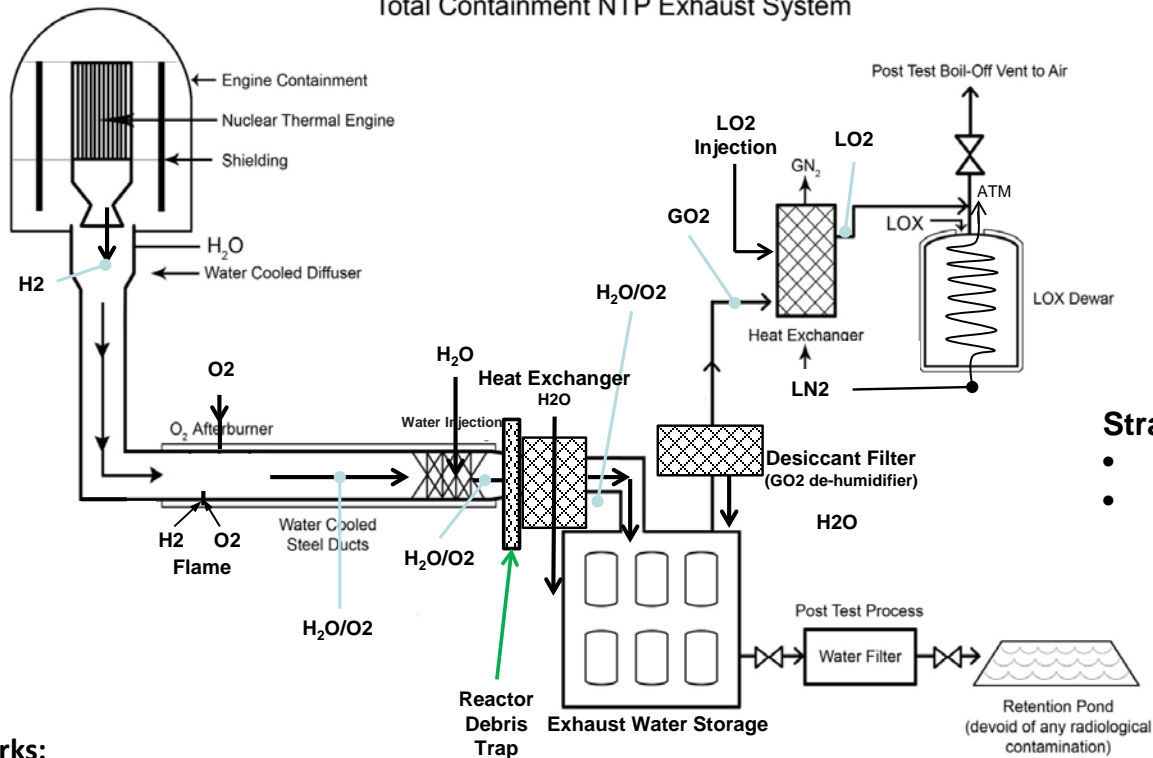

Strategy:

- Fully Contain engine exhaust
- Slowly drain containment vessels after test

How it works:

- Hot hydrogen exhaust from the NTP engine flows through a water cooled diffuser that transitions the flow from supersonic to subsonic to enable stable burning with injected LO₂
 - Products include steam, excess O₂ and potentially, a small fraction of noble gases (e.g., xenon and krypton)
- Water spray and heat exchanger dissipates heat from steam/O₂/noble gas mixture to lower the temperature and condense steam
- Water tank farm collects H₂O and any radioactive particulates potentially present in flow.
 - Drainage is filtered post test.
- Heat exchanger-cools residual gases to LN₂ temperatures (freezes and collects noble gases) and condenses O₂.
 - LOX Dewar stores LO₂, to be drained post test via boil-off



SSC's Acoustic Buffer Zone

Illustration of Comparable NRC-Designated Planning Zones

13,800 Acre

Fee Area/"Exclusion Area"
(20 mi²)

"Fee Area" Avg. Radius ~ 2.5 mi

125,000 Acre

Buffer Zone/"Low-Population Zone"
(195 mi²)

"Buffer Zone" Avg. Radius ~ 7.9 mi

- Slidell, LA
- Population ~ 27,000
- PCD from A3 ~ 8 miles
- ⇒ LPZ < 6 miles

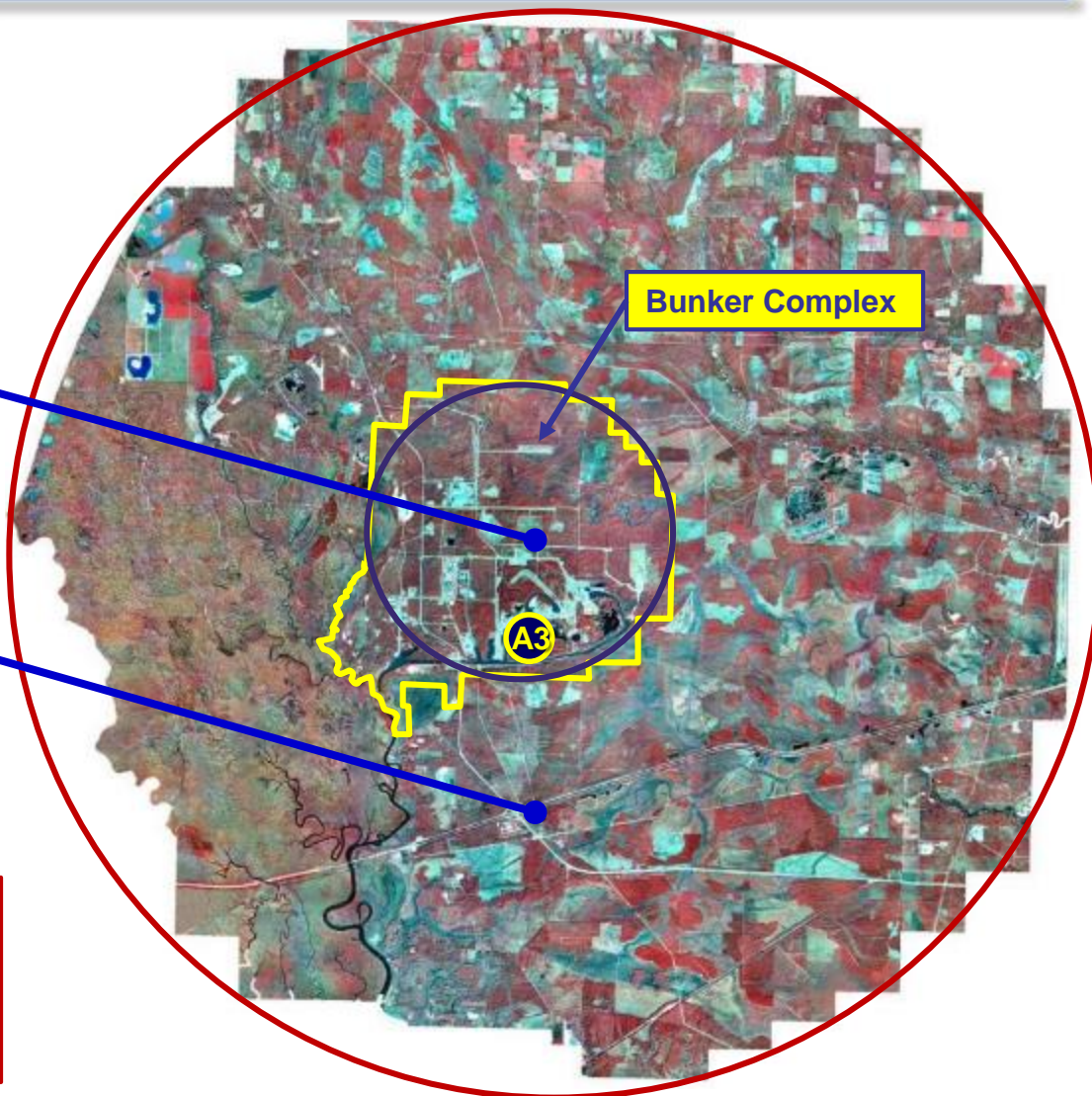

PCD (Population Center Distance ~8 miles) > 1.333 x LPZ ~ 1.333 x 6 miles ~ 8.0 miles

Ref.: NRC Regulatory Guide 4.7



Space Technology Mission Directorate (STMD) Game Changing Development (GCD) Program Nuclear Thermal Propulsion (NTP) Project Overview

Project Manager: Sonny Mitchell, NASA MSFC

Project Objective:

Determine the feasibility and affordability of a Low Enriched Uranium (LEU)-based NTP engine with solid cost and schedule confidence

Approach:

- Evaluate the implications of using LEU fuel on NTP engine design
- Fuel element, reactor, and engine conceptual designs and feasibility analyses
- Mature critical technologies associated with LEU fuel element materials & manufacturing
- Develop an exhaust capture method to facilitate ground testing
- Develop relevant cryogenic propellant management technologies

Roles and Responsibilities

- **MSFC:** PM, SE & Analysis Lead, Cryo ConOps Lead, FE Testing
- **GRC:** Cryocooler Testing, Cryo ConOps Support, Sys. Analysis Support
- **SSC:** Rocket Exhaust Capture System Subscale (RECSS)
- **KSC:** Ground Processing ConOps / Propellant Densification
- **Aerojet Rocketdyne:** LEU Engine Analysis
- **AMA:** Engine Cost Lead
- **Aerospace:** Engine Cost Independent Review
- **BWXT:** Fuel Element (FE) / Reactor Design/Fabrication
- **DOE:** FE / Reactor Design and Fabrication Support

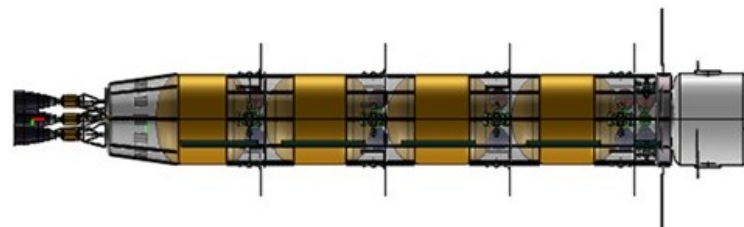
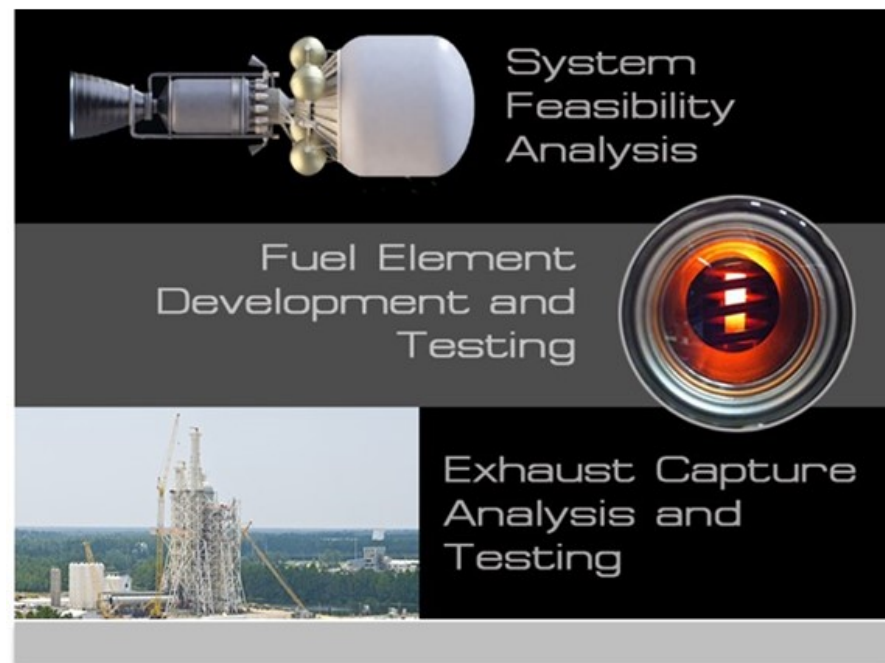
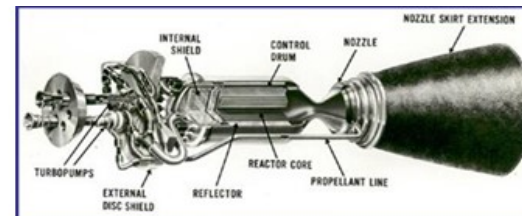



Current NASA NTP Project Baseline

• Nuclear Thermal Propulsion Project (2016-2019)

- Reviewed past design efforts/testing to construct most affordable path to an NTP for Mars missions
 - Baseline Design
 - 25,000 lbf thrust
 - ~500MW
 - Total burn time needed for Mars mission: 31 minutes
 - Exhaust capture ground testing
 - Uses Low Enriched Uranium (LEU)
 - Enables the use of commercial manufacturing methods to arrive at best NTP system design to reduce cost with no impact on performance
 - Use of LEU is consistent with US/international efforts to eliminate HEU in all civilian applications
 - Enables tremendous programmatic flexibility, increasing choice of facilities, project participants and launch vehicles

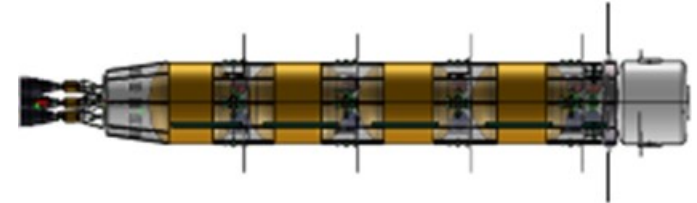

NTP can abort up to 3 months into Mars mission

Chemical can only abort up to 5 days into Mars mission

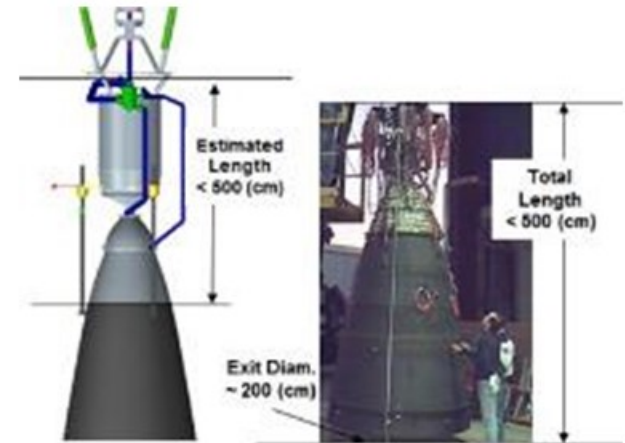

Size comparison: Baseline 25klbf NTP (Left) vs. RL10 (right) (Courtesy Aerojet Rocketdyne)

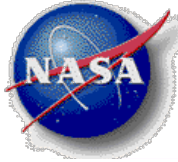

NTP Engine Development: Big Picture

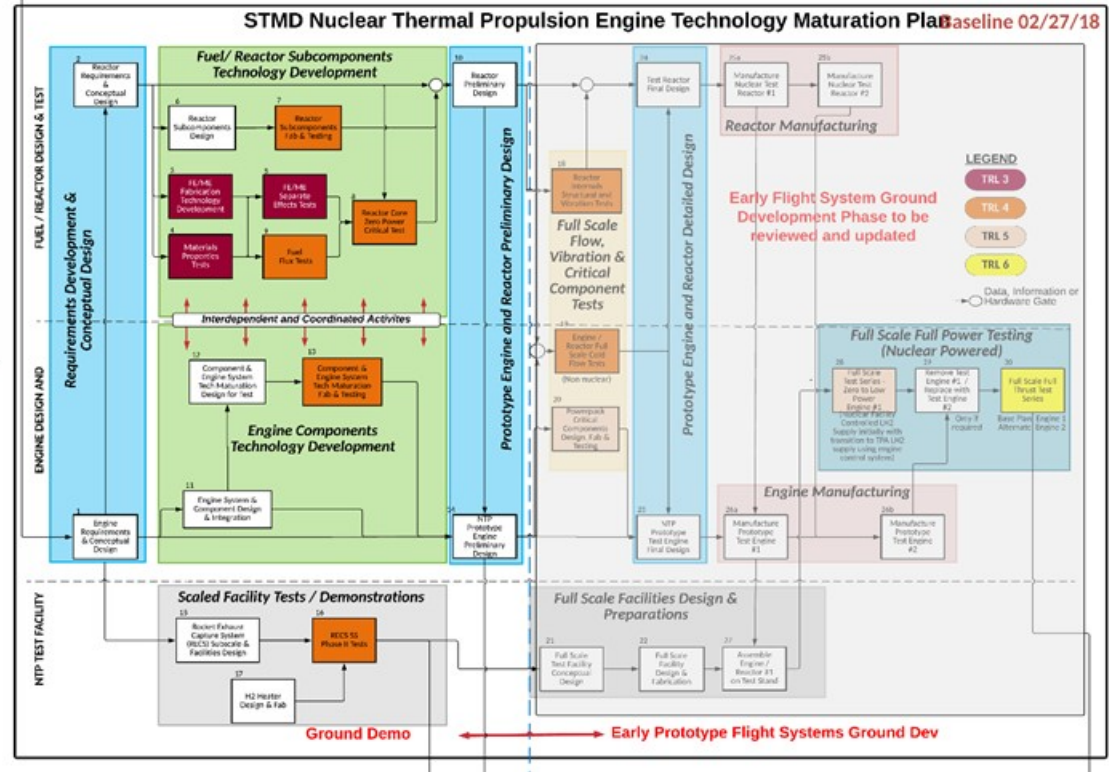
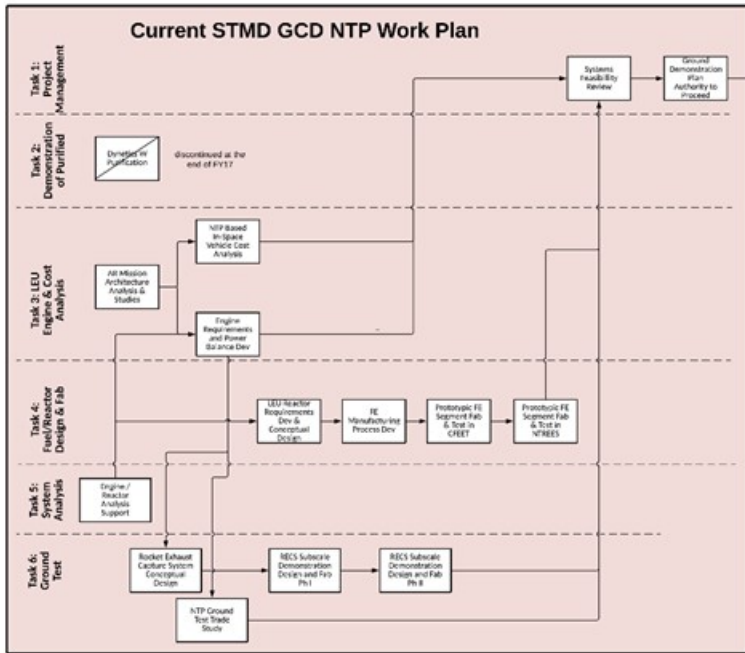



NTP Engine Development: Current GCD NTP Project

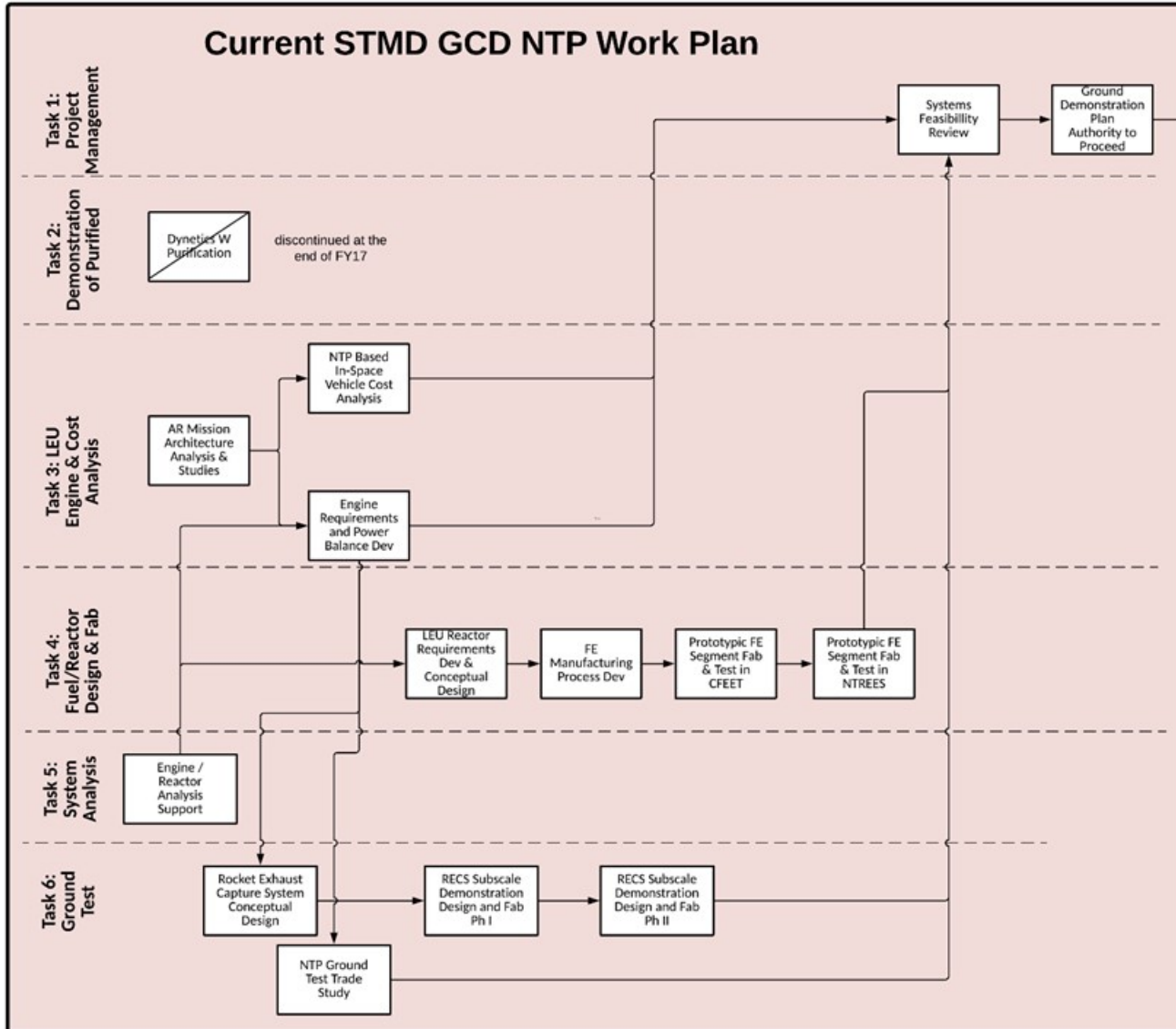



Baselined NTP Technology Maturation Plan: Basis for Ground Demonstration Project

Technical Approach / Milestones

• Task 1: Project Management, MSFC

- Requirements & Concept Development
- Preliminary Design of Prototype Engine System

Key Milestones:

- ① Reactor Preliminary Design (Blk10)
- ② Engine Prototype Preliminary Design (Blk 14)

• Task 2: Fuel/Reactor Design & Test

- Fuel/Moderator Elements (FE/ME) Fabrication Technology Development
- FE/ME Material Properties/Separate Effects Tests
- FE/ME Radiation Flux Tests
- Representative Reactor Zero Power Critical Tests

Key Milestones:

- ① FE/ME Separate Effects Testing Complete (Blk 5)
- ② Fuel Radiation Tests Complete (Blk 9)
- ③ Representative Reactor Zero Power Critical Test Complete (Blk 8)

• Task 3: Engine Design & Test

- NTP Component & Engine System Technology Maturation
 - Demonstration key NTP technologies not typical of conventional liquid rocket engine components (life, operating range, total duty cycle, materials selection)

Key Milestones:

- ① Components & Engine System Demonstration Testing Complete (Blk 13)

• Task 4: NTP Test Facility

- Rocket Exhaust Capture System Scaled Demonstration
- Non-nuclear Scaled Simulated Engine System Demonstration

Key Milestone:

- ① Scaled Exhaust Capture Phase II Test Demo Complete (Blk 16)

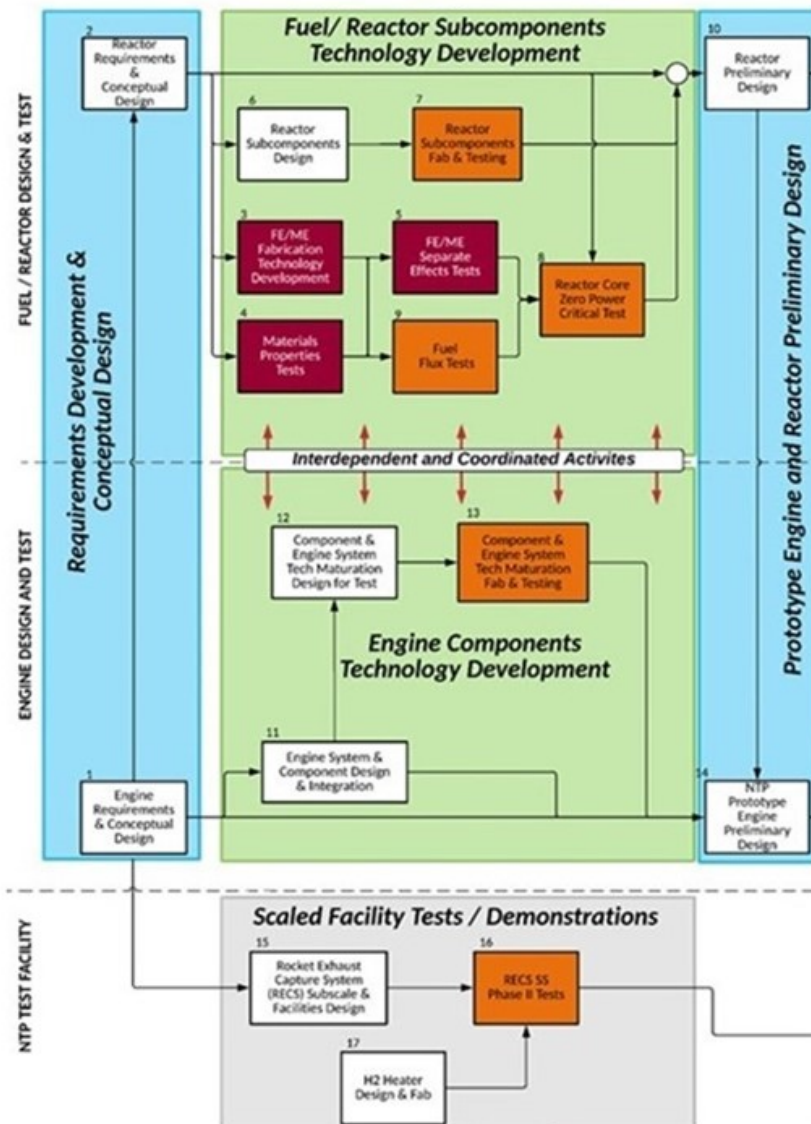



Testing to Demonstrate Reactor Component Design, Fabrication, and Application of Technology

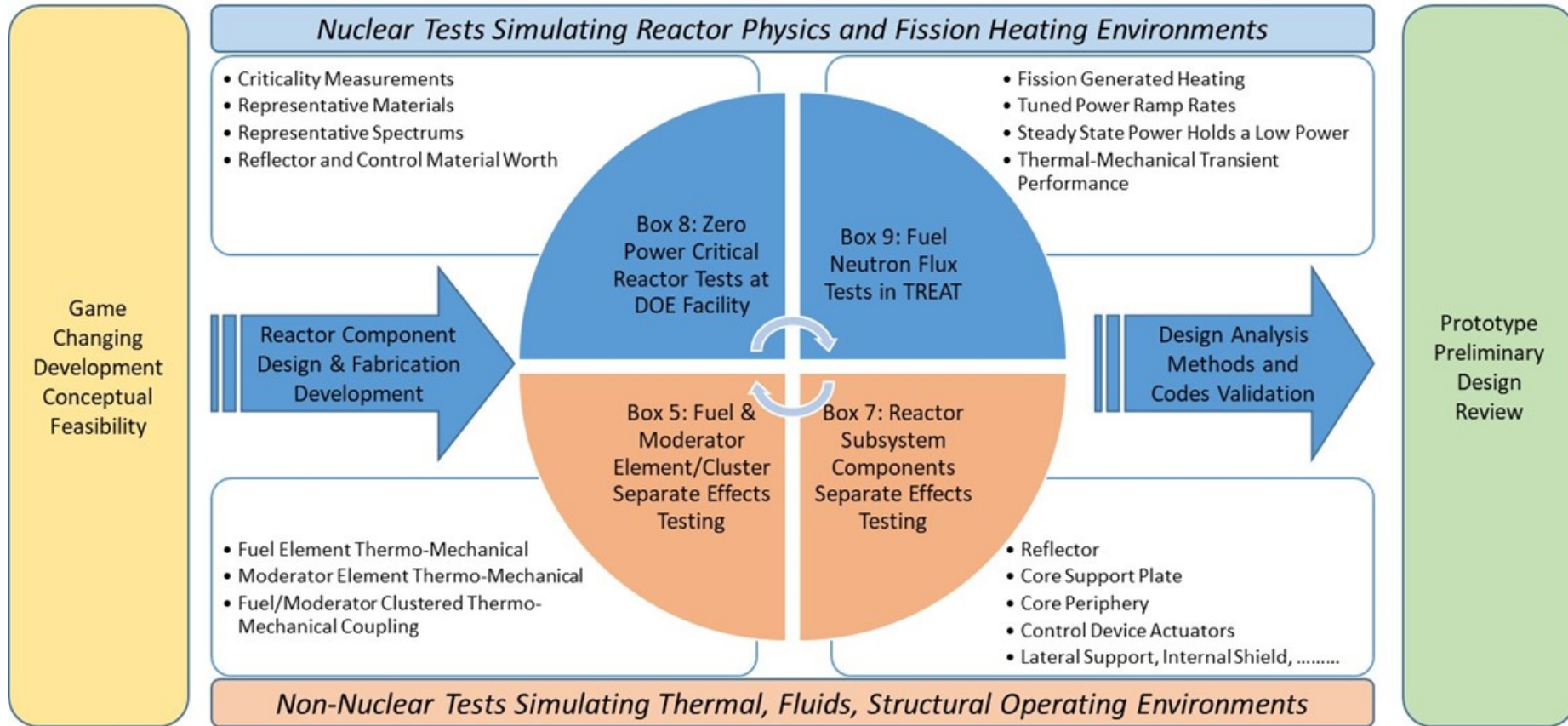



CFEET Segment Test

- Completed successful test of the first fuel element (FE) specimen, C0, in the MSFC Compact Fuel Element Environmental Tester (CFEET) on 8/9/18
 - C0 specimen was a pathfinder for FE fabrication techniques
 - C0 was a 0.75 inch hexagonal “can” with solid laser-welded end caps filled with a surrogate powder
 - Reached the specimen target temperature of 2200K with a hold time of 20 minutes.
 - Next test of the specimen is planned to reach a temperature of 2400K

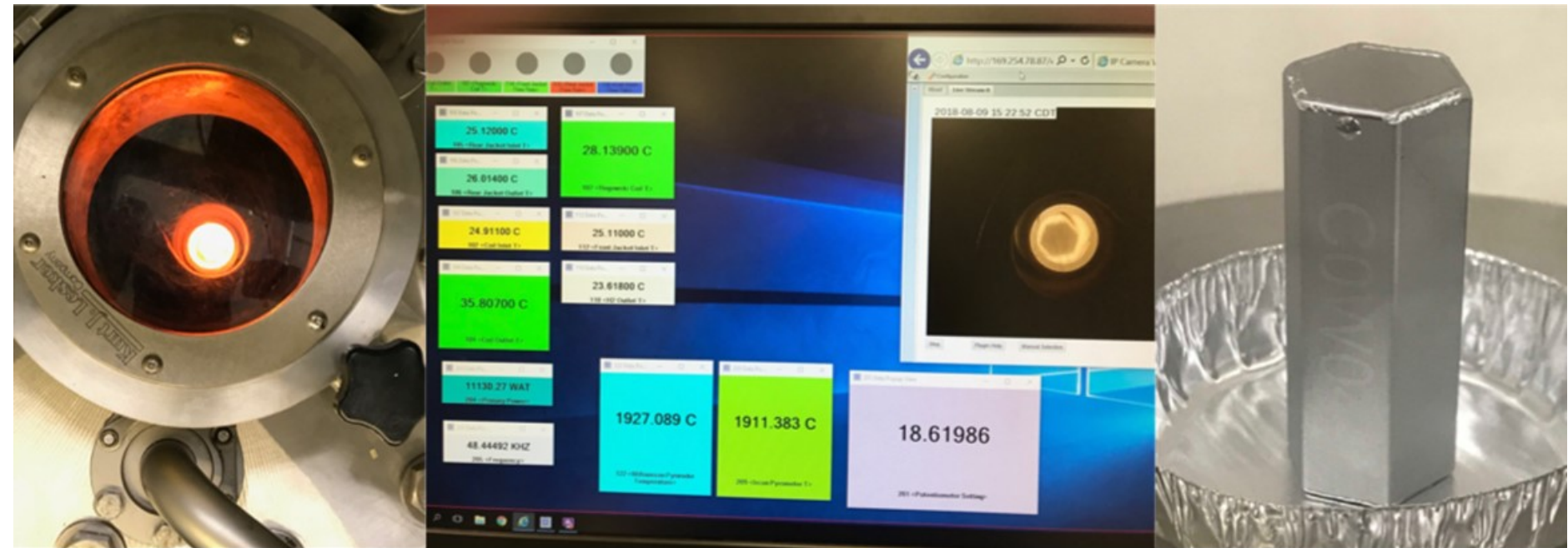



Agile Development Approach NTP Engine

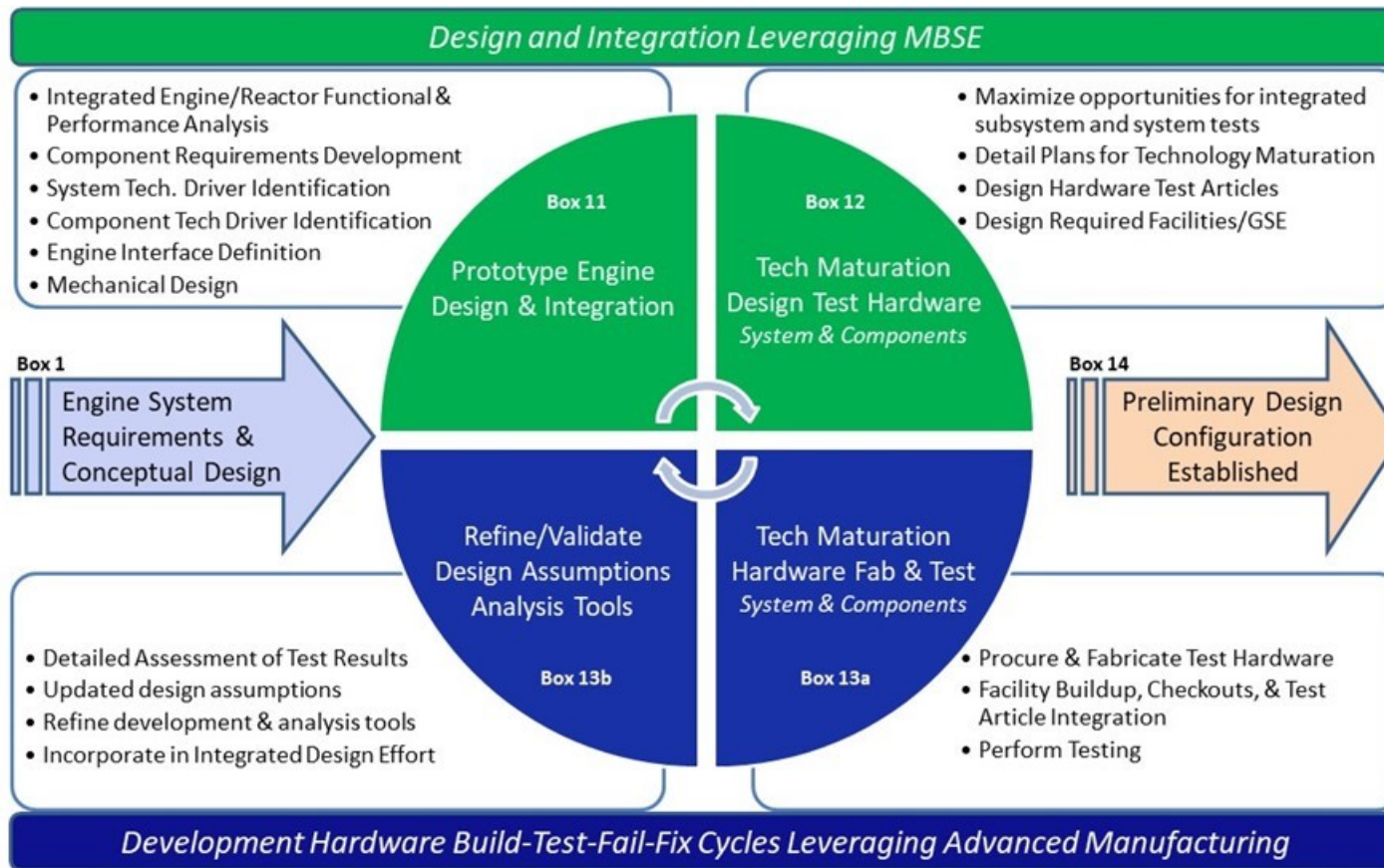

Game Changing Development Conceptual Feasibility

Prototype Engine Preliminary Design Review



GCD NTP Project Summary

- The STMD NTP project is addressing the key challenges related to determining the technical feasibility and affordability of an LEU-based NTP engine
 - The project is maturing technologies associated with fuel production, fuel element manufacturing, engine exhaust capture, and cryogenic propellant management
 - The project is developing reactor and engine conceptual designs
 - The project is performing a detailed cost analysis for developing an NTP flight system
 - An NTP system could reduce crew transit time to Mars, increase mission flexibility, and decrease the number of SLS launches required to undertake a human exploration campaign



Observations

- Space fission power and propulsion systems are game changing technologies for space exploration.
- First generation NTP systems could provide significant benefits to sustained human Mars exploration and other missions.
 - Potential for Earth-Mars transit times of 120 days; 540 day total Mars mission times; reduced crew health effects from cosmic radiation and exposure to microgravity; robust Mars architectures including abort capability.
 - Faster response times, improved capability, and reduced cost for cis-lunar operations. NTP derivatives could enable very high power systems on lunar surface (ISRU) and in space.
- Advanced space fission power and propulsion systems could enable extremely ambitious space exploration and development.