



Arcjet Ablation of Stony and Iron Meteorites

Parul Agrawal

NASA Ames Research Center, Moffett Field, CA, 94035

Peter Jenniskens

SETI Institute, Mountain View, CA 94043

Eric C. Stern, James O. Arnold, Yih-Kanq Chen

NASA Ames Research Center, Moffett Field, CA, 94035

2018 AIAA AVIATION FORUM
June 29, 2018, ATLANTA, GA



2013 Chelyabinsk Event



In February 2013, the blast over Chelyabinsk in Russia released the equivalent of 500,000 tons of TNT. Around 1,000 people were injured in that explosion - mostly as result of flying glass from smashed windows. The meteoroid, estimated to be about 10 tons, entered the atmosphere at a speed of 19.15 km/s.

Planetary Defense Coordination Office Mission Statement:

This office was established at NASA HQ to coordinate planetary defense related activities across NASA.

Lead national and international efforts to:

- Detect any potential for significant impact of planet Earth by natural objects
- Appraise the range of potential effects by any possible impact
- Develop strategies to mitigate impact effects on human welfare

ATAP Functions

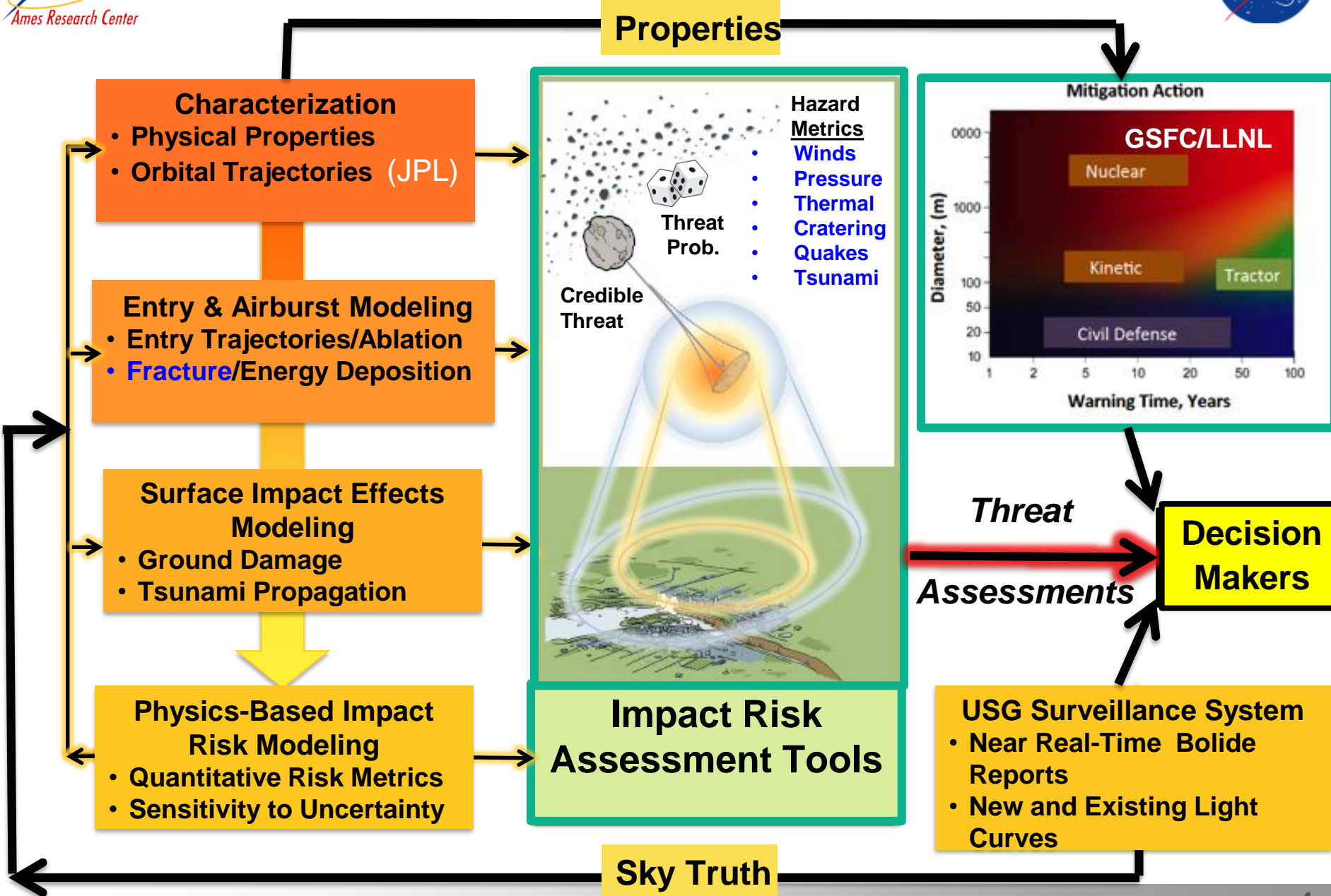

Capsules vs. Asteroid Entry



Apollo Entry



Chelyabinsk Entry

- Can some of the modern computational analysis tools used in design of Entry capsules be used for simulation of asteroid entries?
- Can we develop asteroid models for :
 - Material thermal response
 - Material structural response, including fragmentation
 - Energy deposition along asteroid trajectory in the atmosphere, *i.e.*, light curves

In order to achieve flight relevant condition, assist development of higher fidelity thermal response models and radiation models a unique arcjet campaign was conducted in the 60 MW interaction heating facility at NASA Ames Research Center.

Arcjet Test Objectives

- **Provide quantitative data for meteoroid ablation model development**

State-of-the-art meteoroid ablation models are based primarily on observational data from meteoroid light curves. There is little to no experimental data on meteoritic material at flight relevant conditions. These experiments provide unique and invaluable data for development of High-fidelity models and simulation tools.

- **Investigate the emission from the ablation products in-situ using spectroscopy**

The arc jet facility provides us the unique opportunity to produce excited ablated species and perform emission spectroscopy to examine their composition. It is known from meteoroid spectra that the lines and bands from the metallic species dominate the spectrum. Data from this effort will provide us insight into these observed spectra, as well as inform and validate radiation models for meteoritic ablation products.

Materials Tested

- **Flood Basalt (Pullman, Washington Area)**
 - Various silicate based minerals, porosity and fine grain matrix
- **Tamdakht (H-5 Meteorite)**
 - 2008 Fall in Morocco
 - Besides the silicate based minerals that are found in terrestrial rocks, these also had 20-25% Ni-Fe based alloys content
- **Campo Del Cielo (Ni-Fe Meteorite)**
 - 4,000-5,000years old, found in Argentina
 - 92% Iron, 6.67% Ni, 0.43% Co, 0.25% P, 87 ppm Ga, 407 ppm Ge, and 3.6 ppm Ir.
 - The pieces contain very high density of hard inclusions that are assumed to be the cause of fragmentation during entry
- **Fused Silica**

Sample Design and Assembly

- Test articles were machined as 45 deg sphere cones (micro probes!) to enable high fidelity simulation of the test environment and material response

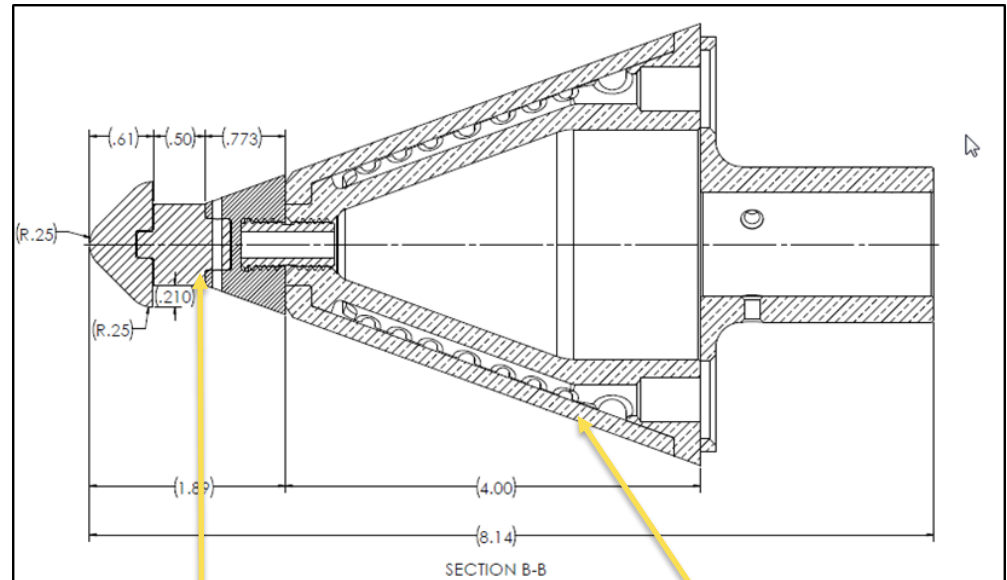

TUFI coated LI-2200 stems

Graphite model holder

Water cooled copper cone

Test Environments

All the samples were tested in IHF, with 6.0 inch nozzle at the facility max settings

Measured conditions with calibration gages

Facility	Nozzle (cm)	Run	Calibration # 1	Measured Heatflux (W/cm ²)	Calibration # 2	Stagnation Pressure (kPa)	Bulk Sonic Flow Enthalpy (MJ/kg)
IHF	15.25	1	13 mm Co-axial gage	3409.35	9 mm pressure gage	126.1	20.6
		2		3290.8		126.5	20.7

Heating rates (~4 kW/cm²) produced in the experiment comparable to 30m asteroid at 20km/s at 65km altitude

CFD predictions for sphere cone geometry

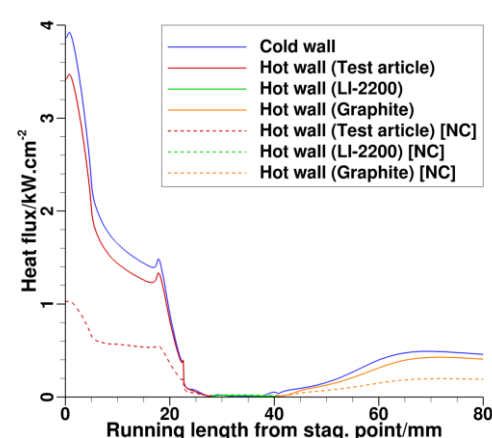
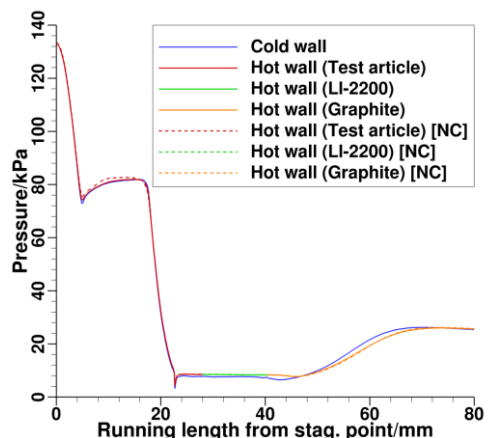
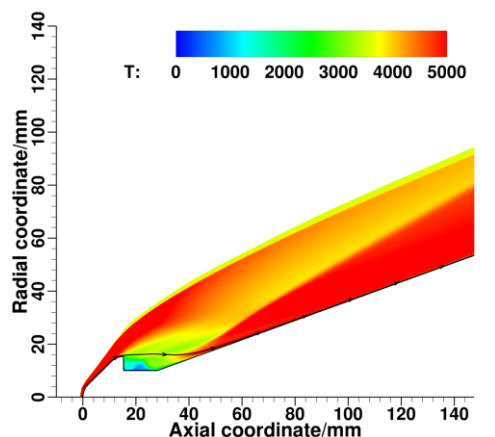

Instrumentation

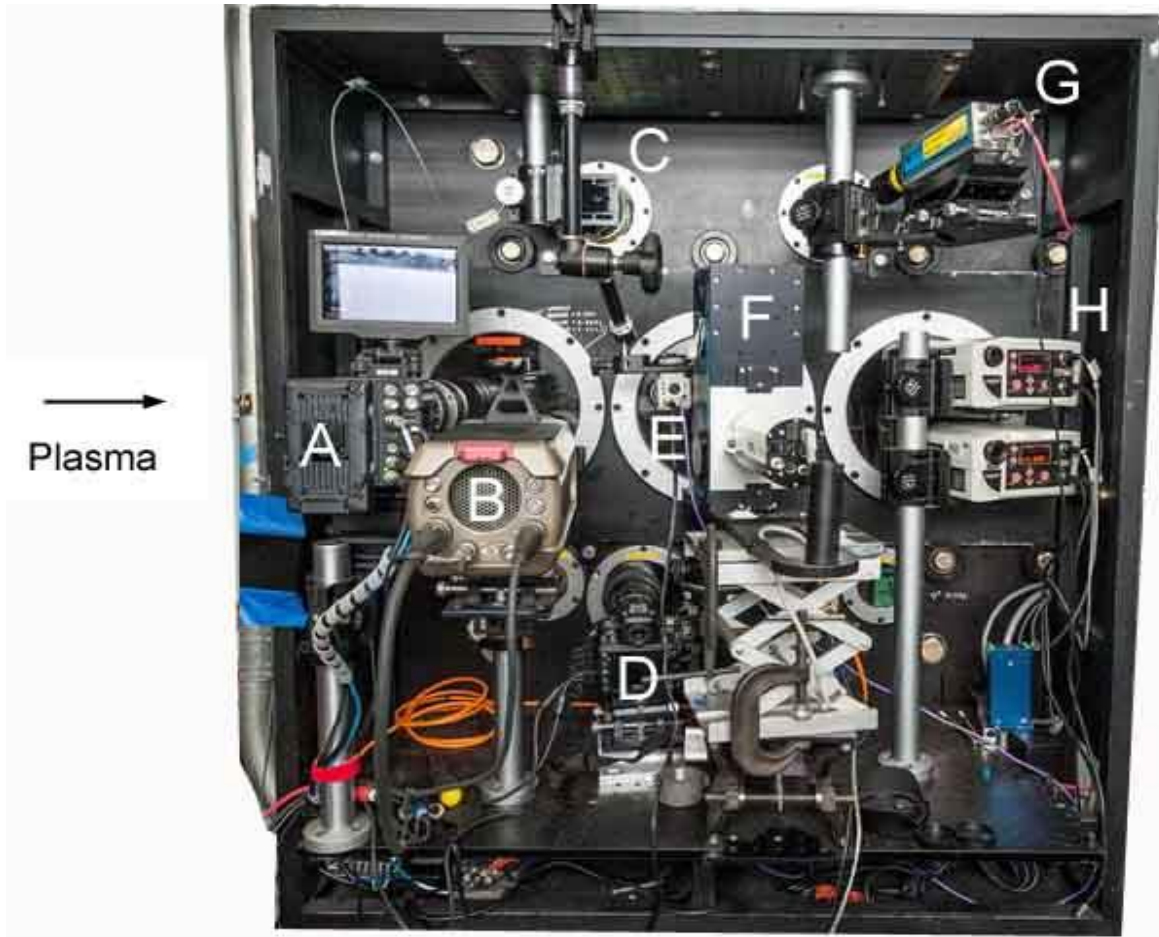

- (A) RED Epic Camera
- (B) Phantom Camera
- (C) unoccupied
- (D) Digital Still Camera
- (E) Hitachi KP-D20A camera
- (F) Echelle Spectrometer
- (G) HD Video Camera
- (H) Pyrometers

Instruments mounted on the west-side window

RESULTS

Flood Basalt – Imaging

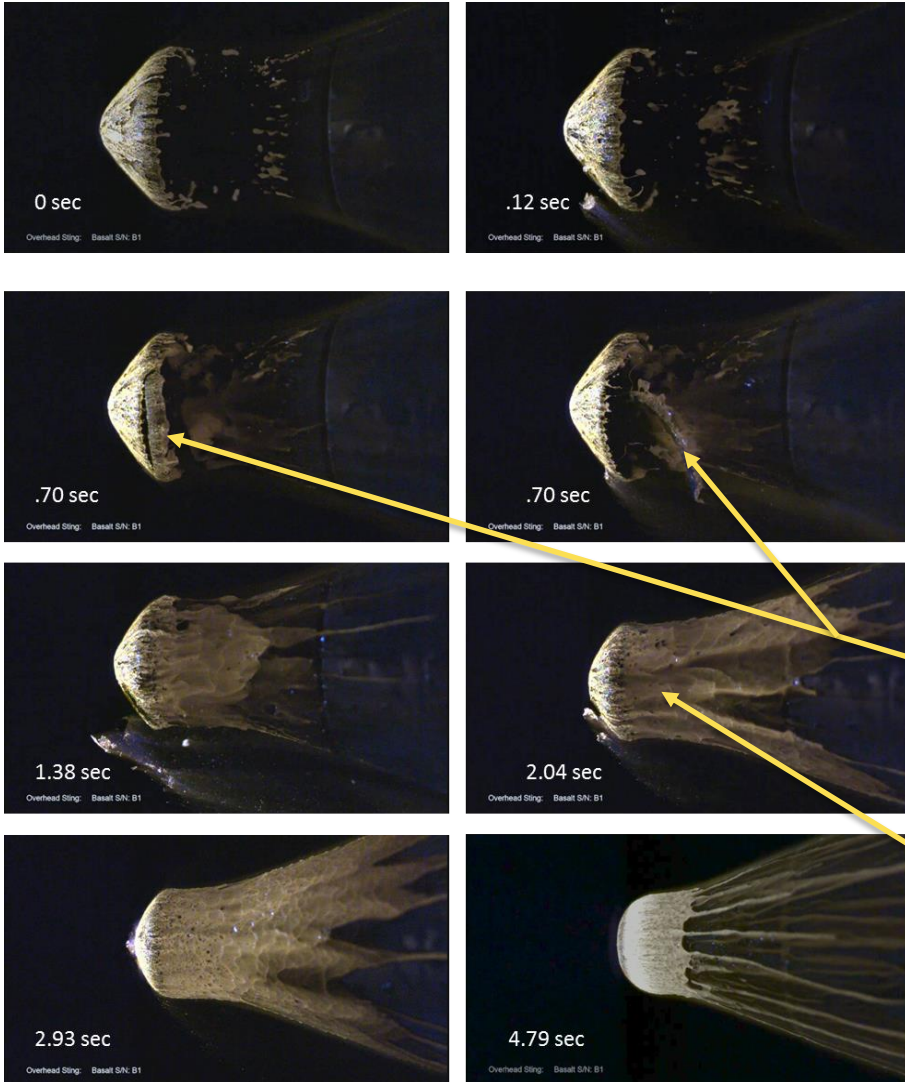

Significant
spallation/frag
mentation

Melt flow

Basalt was our very first sample. We exposed it for 5 second but the sample itself was gone in ~3 second due to significant melting.

Flood Basalt – Surface Temperature and Spectroscopy

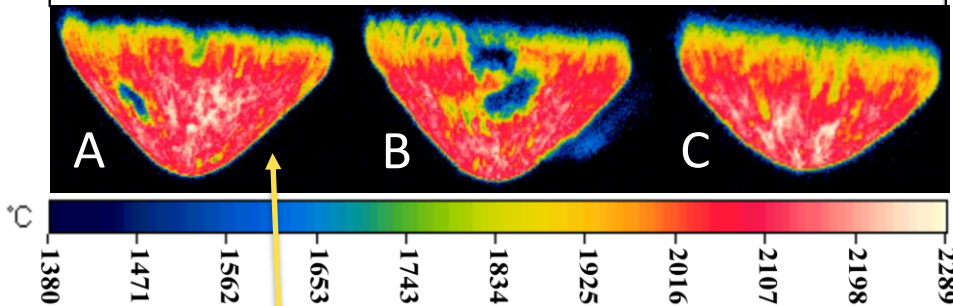
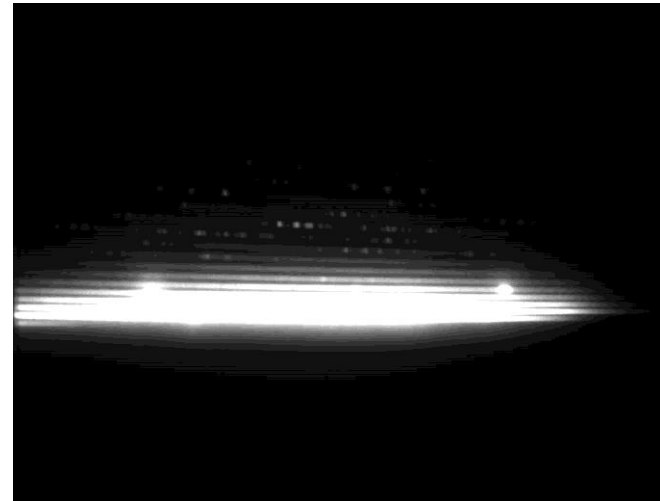
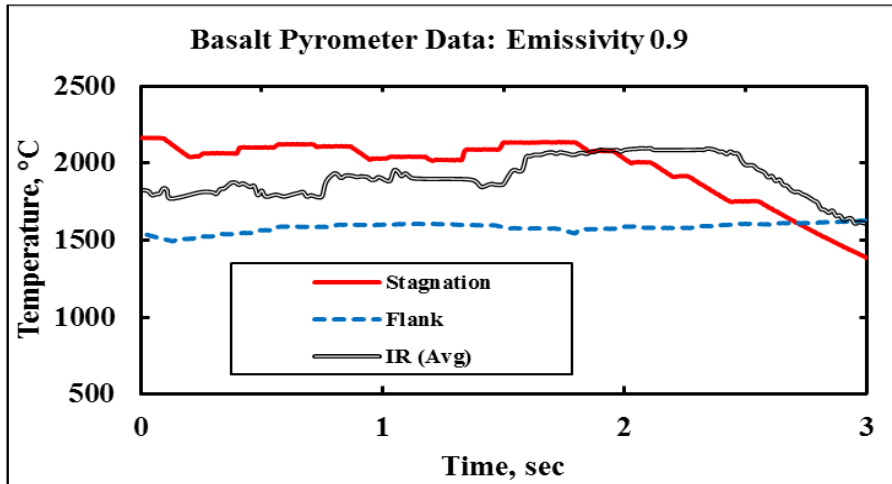

The surface temperature reached 2000°C (pyrometer M668L), well above the melting point.

Emissions at shorter wavelengths are well exposed, and show many emission lines from copper (a contamination effect due to the Arcjet electrodes)³, and ablated basalt species of sodium, iron and calcium.

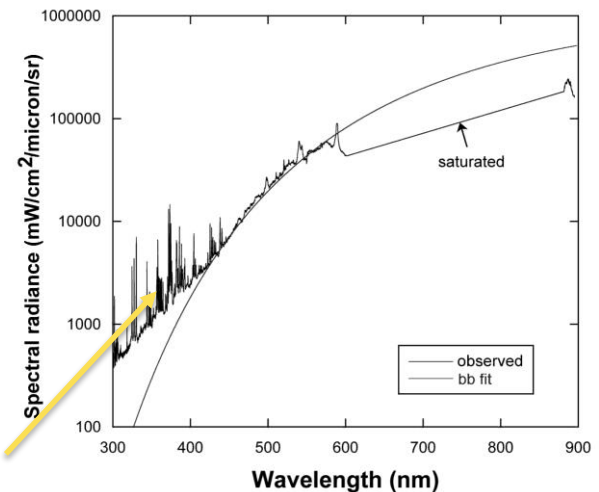

Tamdakht - Imaging

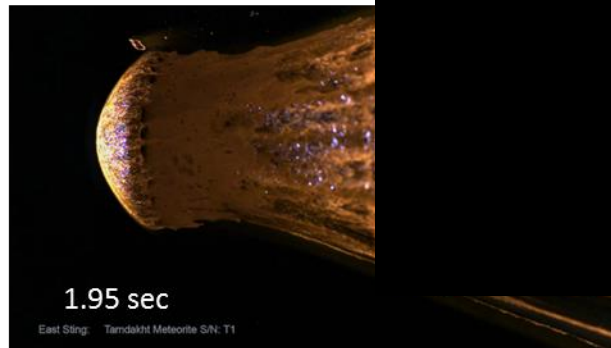
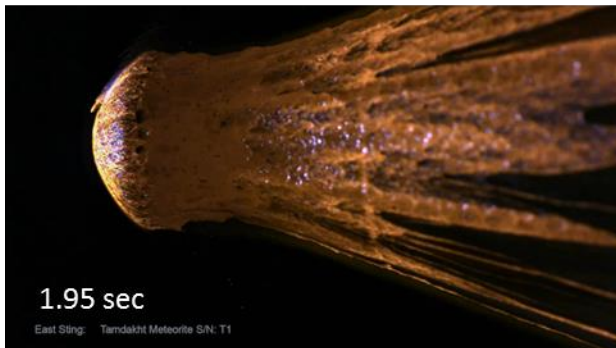
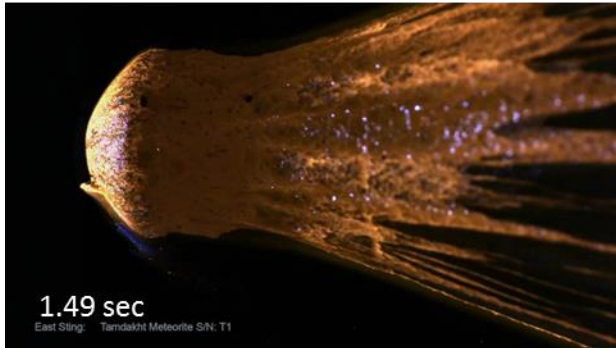
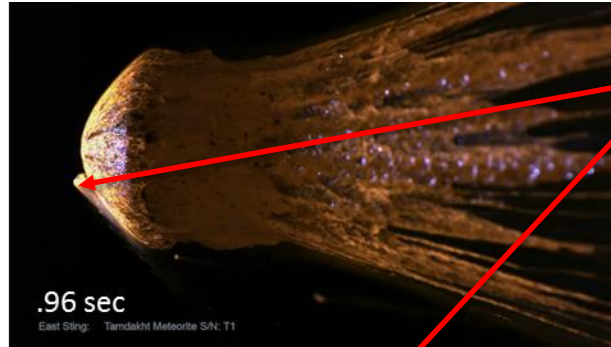
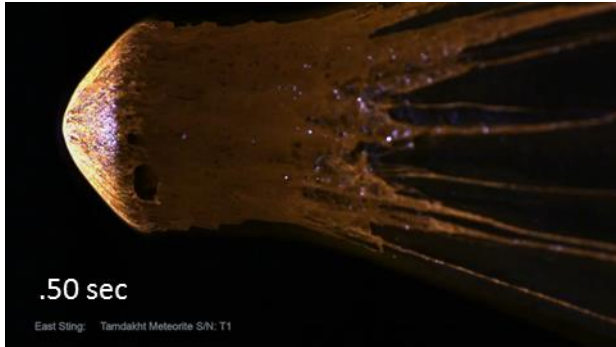

Fragmentation
(formation of mini
meteorites)

Wide spread melt flow,
lower melt viscosity
compared to basalt or
fused silica

Exposure – 2 seconds

Tamdakht - Spectroscopy

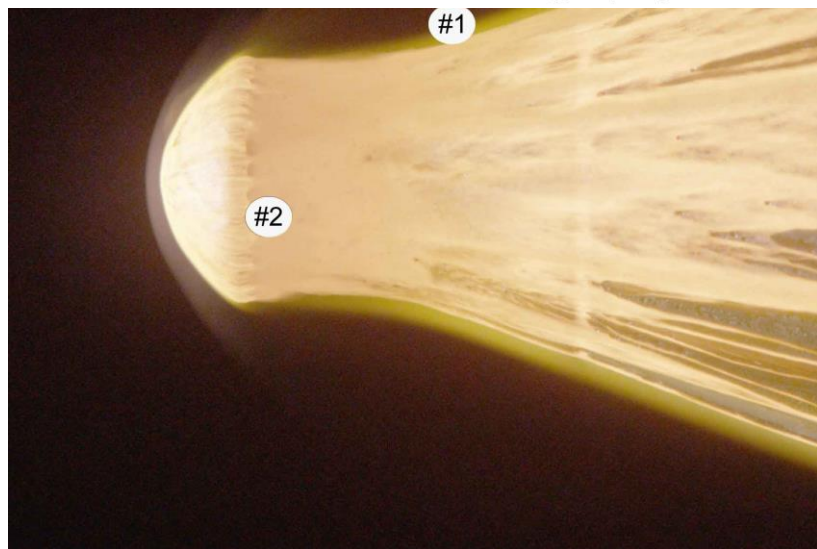
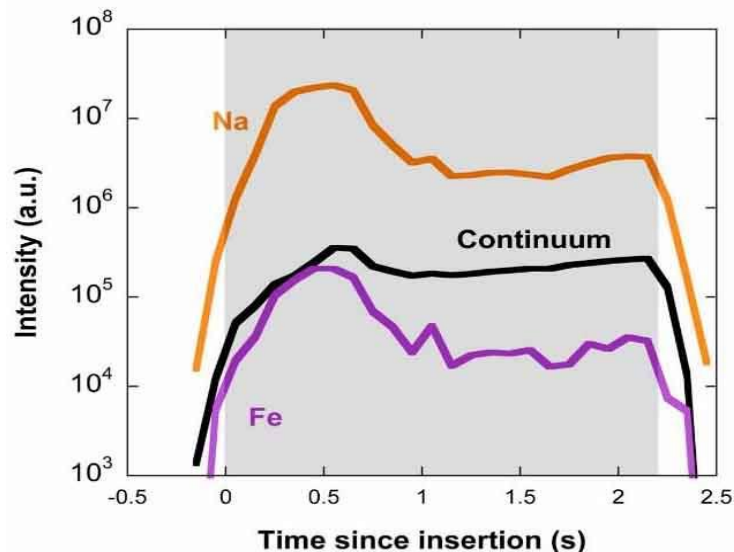
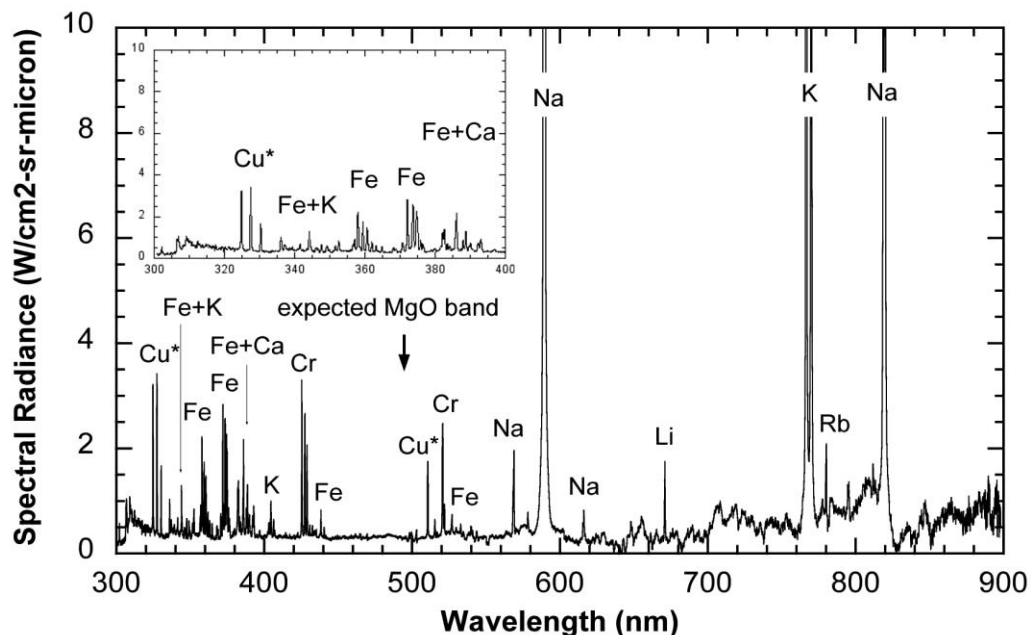

- Strong alkali metal atomic lines of Li, Na, K and Rb are detected.
- The spectrum also contains meteoritic emissions of Fe and Cr.
- Emissions from Cu were also present in the free-flow spectrum, but originated in the Arcjet itself (marked by *)
- The time evolution of the sodium and iron emissions was captured that shows evidence of differential ablation

Tamdakht – Surface Temperature and Ablation

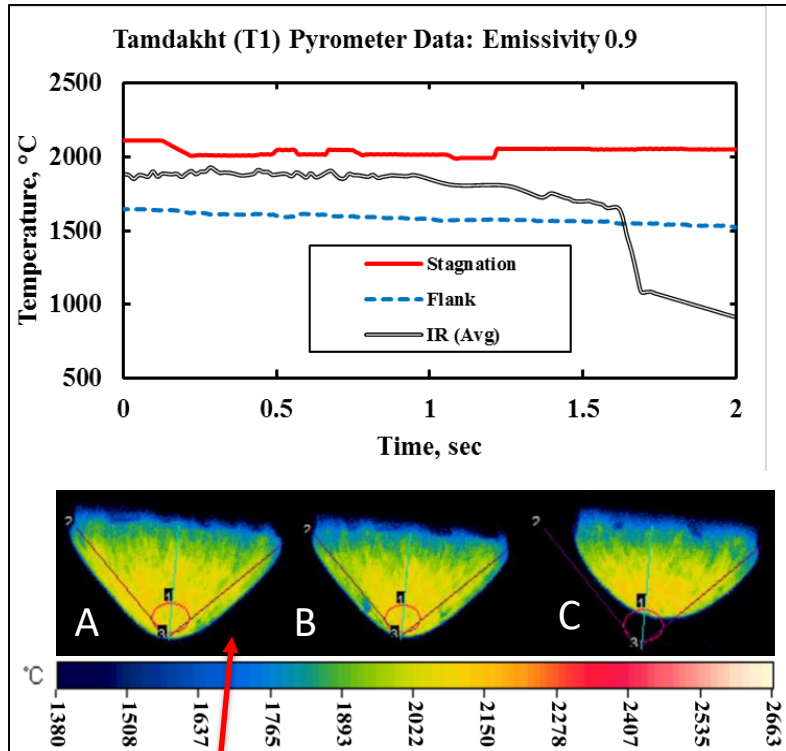

the surface temperature exceeded 2000°C (well above the expected melting point of Tamdakht)

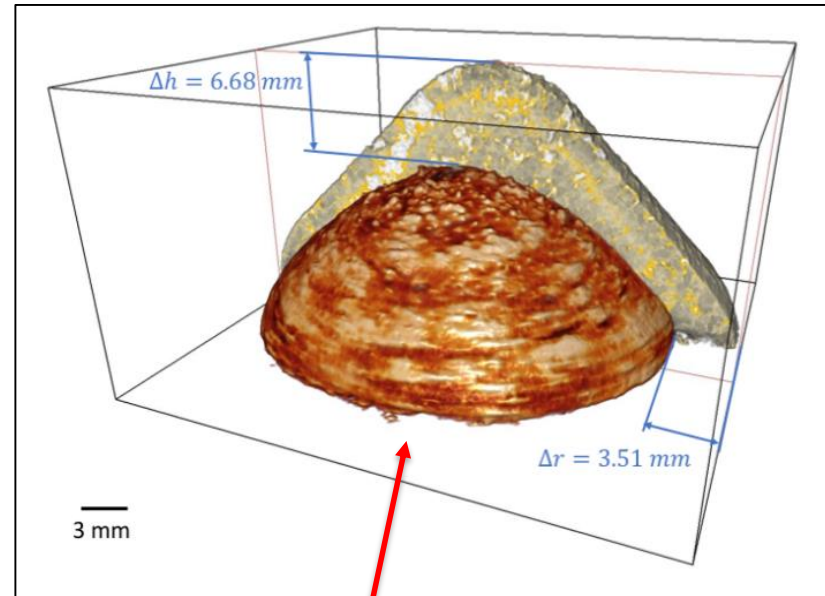

Surface recession was measured by CT scans and laser scans. The recession was more pronounced at the stagnation surface causing a blunt shape

Campo-Del Cielo - Imaging

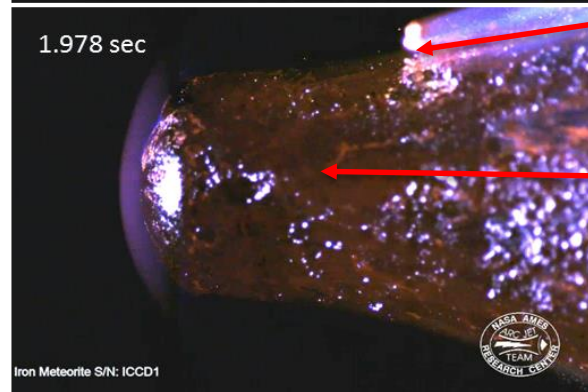
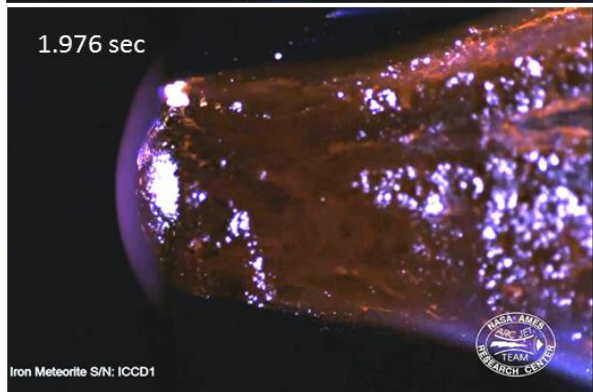
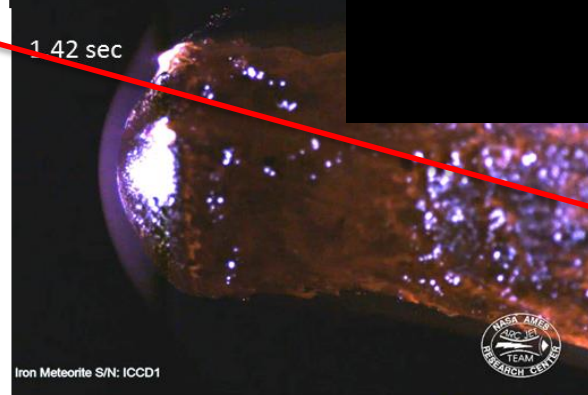
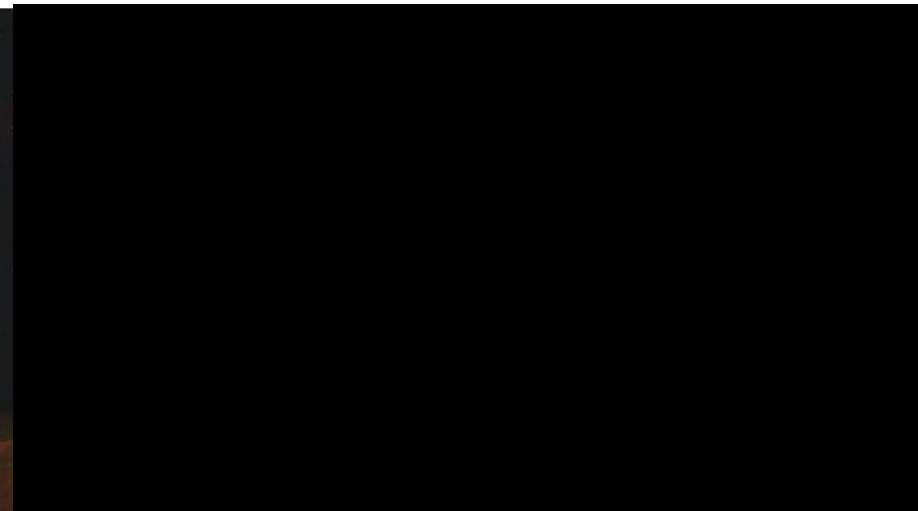
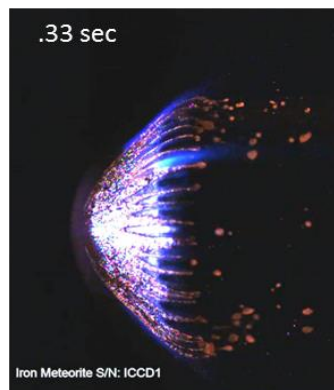
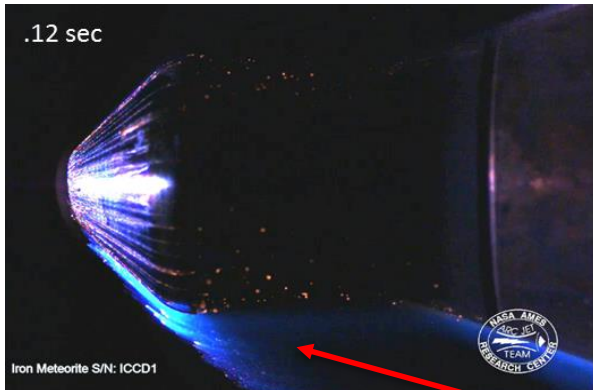

Emission of blue light during fragmentation

Separation of hard inclusion

Wide spread melting and oxidation

The sample was gone in ~2 seconds

Campo-Del Cielo – Surface Temperature and Spectroscopy

Iron Meteorite (ICCD1) Pyrometer Data: Emissivity 0.3

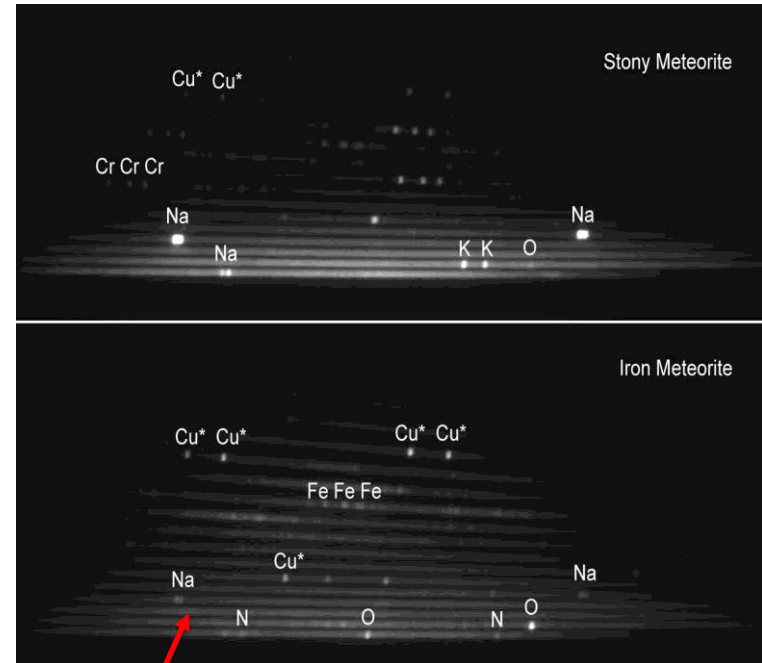
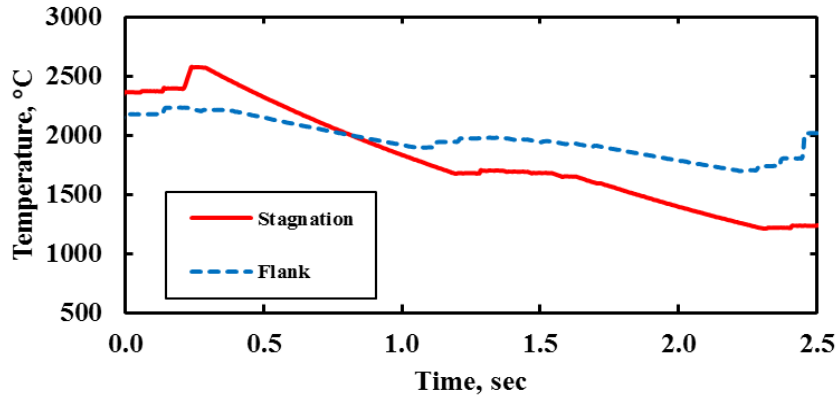

Strong air plasma emissions from O and N, arcjet electrode Cu atoms, Weak emission lines of Fe and Na

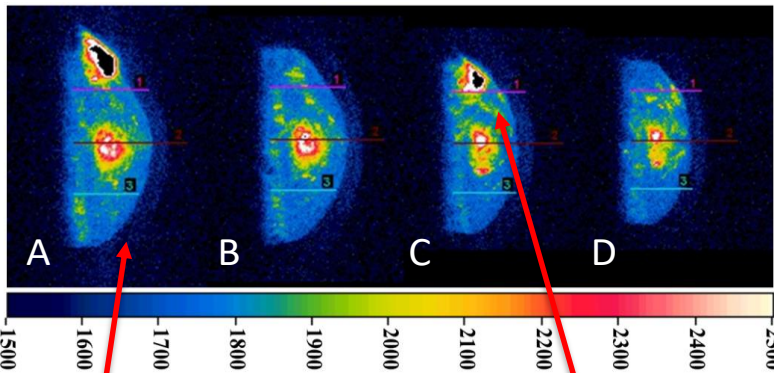
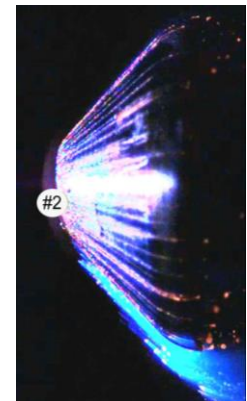

surface temperature well above melting point (1538 °C)

Hard refractory inclusion saturated the channel

Fused Silica - Imaging

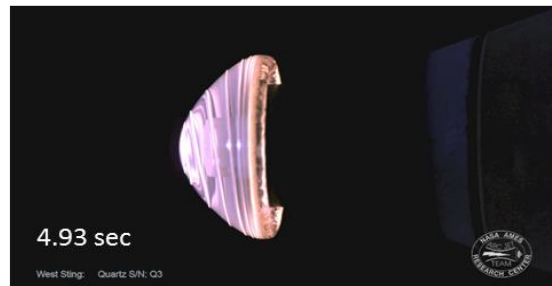
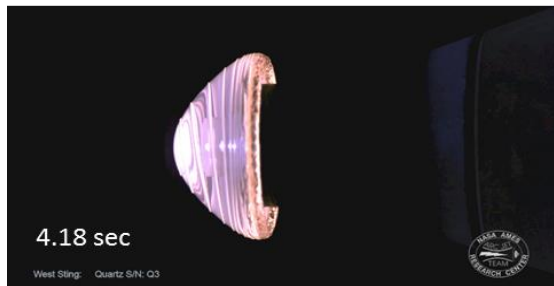
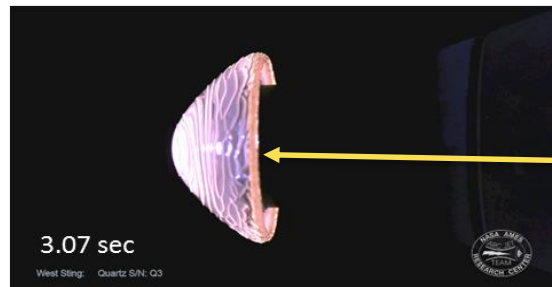
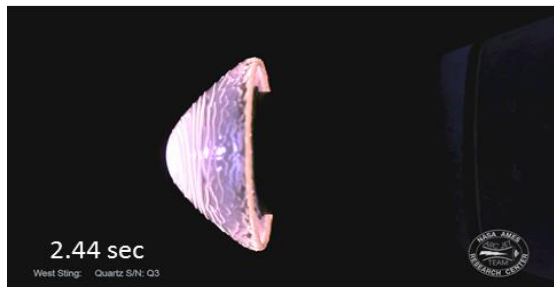
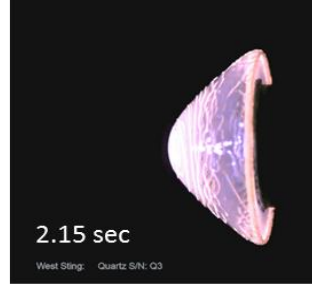
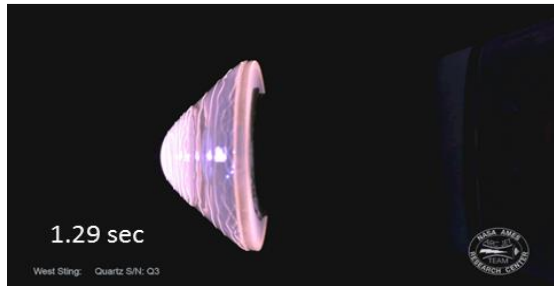
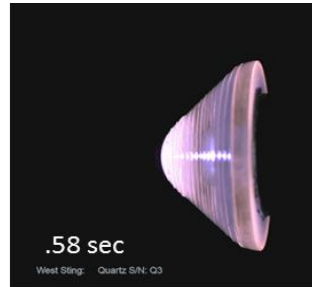
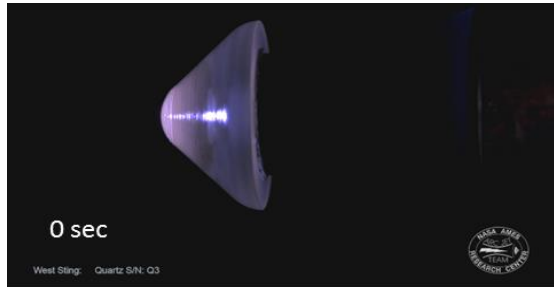

Significantly lower ablation rate and melt flow due to higher viscosity than Basalt or Tamdakht

Sample was exposed for 5 seconds

Fused Silica – Surface Temperature and Recession

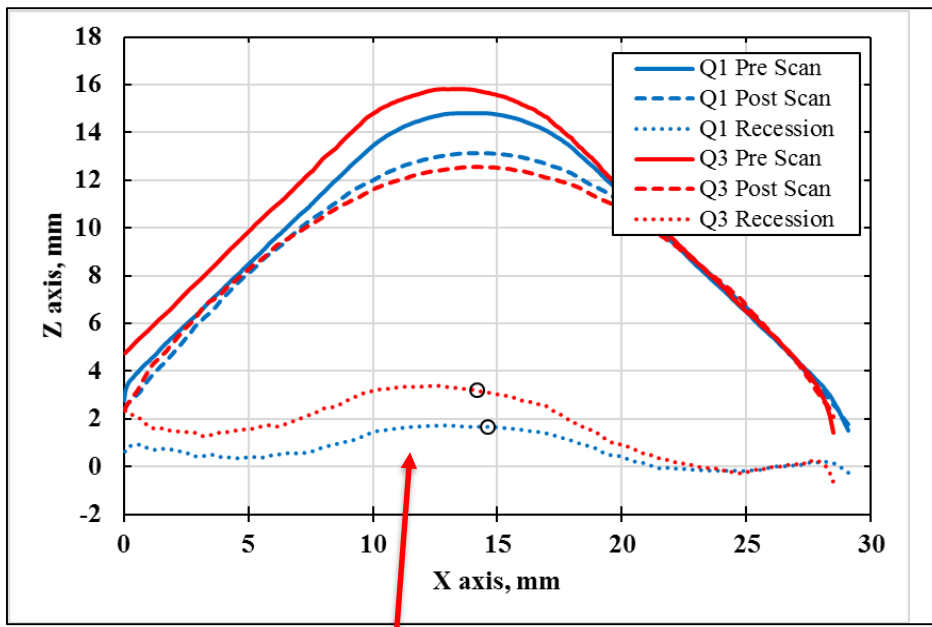
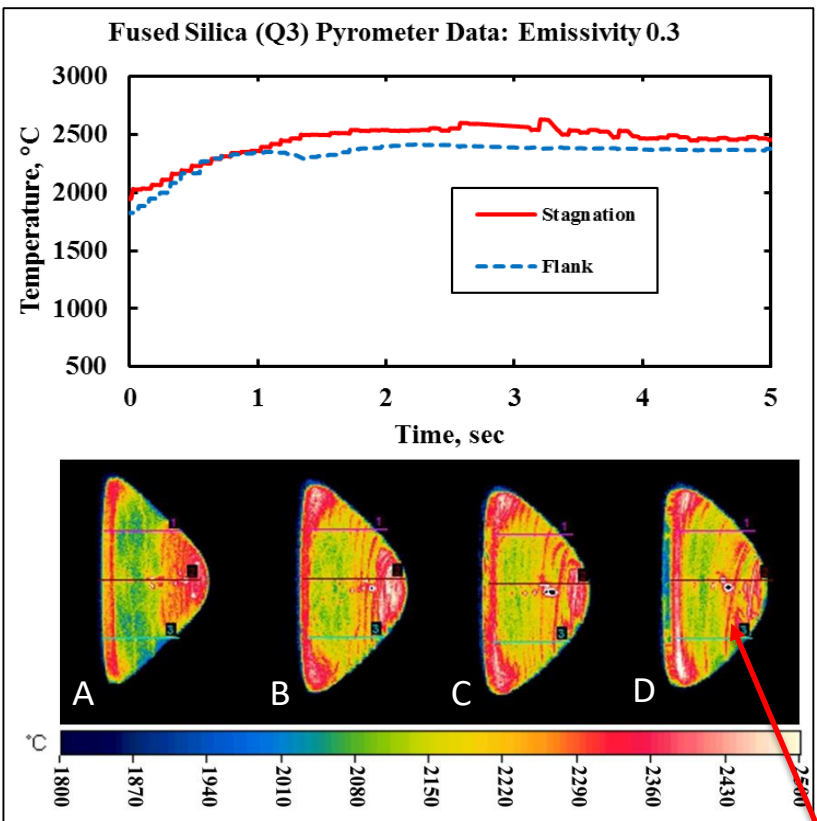

slower melt flow and ablation due to very high viscosity.

Silica melting point: 1710°C,
 boiling point: 2230°C
 Surface temperatures ~ 2500°C
 well exceeds the boiling point.

same swirl pattern as a difference in temperature around the swirl.

Fused Silica - Spectroscopy

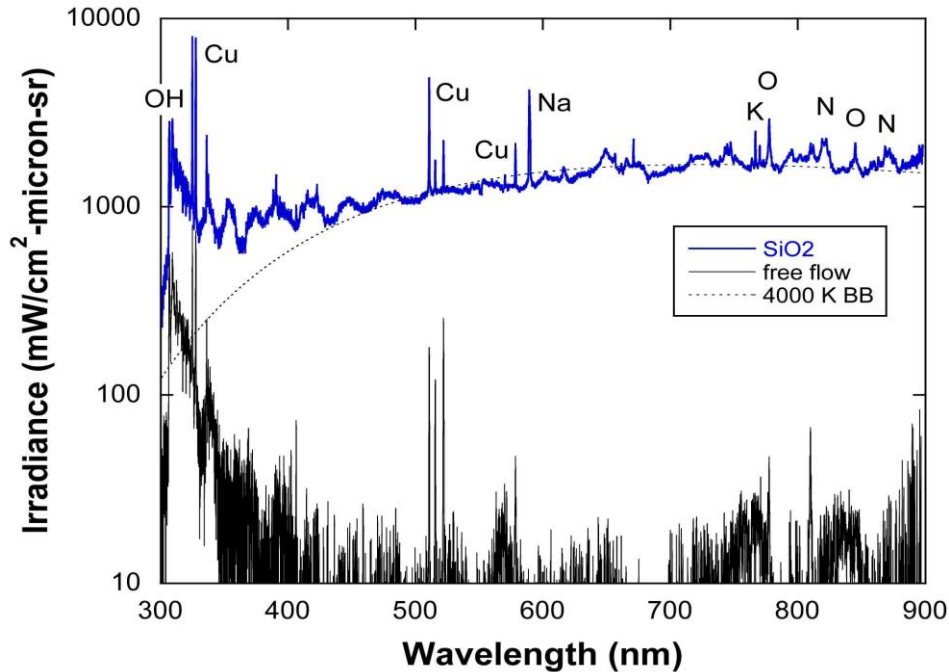

The emission spectra was quite different from those of the meteorites.

The 310-nm OH band (due to water-leaks) is well detected.

Atomic emission lines are from copper (a contaminant in the Arcjet flow) were present

Weak lines from air plasma emissions (O, N), and other weak lines from sodium and potassium (impurity in the glass)

Summary and Conclusions

- A successful test campaign of meteorites and terrestrial analogs was conducted in the Interactive Heating Facility (IHF) at NASA Ames Research Center.
- Exposure to the Arcjet plasma flow caused significant melt in the stony Tamdakht and the iron Campo Del Ceilo meteorites as well as in basalt samples, indicating we are in melt dominated regime.
- From the measured rate of recession, an effective heat of ablation was calculated to be ~ 2 MJ/kg, that is much lower than the traditional assumed value of ~ 8 MJ/kg
- Bias in ablation parameter toward the low-end results in lower altitude airburst, and therefore larger ground damage footprints
- High speed video shows that material is also lost by spallation (Basalt more than stony meteorites) and the shedding of refractory inclusions (iron meteorite).
 - The loss of inclusions offers new insight into how high melting point materials can survive reentry when carried by lower melting point matrix.
- The analysis from Tamdakht emission spectra shows lower excitation temperatures than expected, with emissions being primarily from alkali-metals that emit from the ground state. This data will improve our insight into how to interpret natural meteor spectra during atmospheric entry.

Acknowledgments

- Dinesh Prabhu (CFD Analysis)
- Erika Rodriguez (IHF test engineer) and IHF staff
- Megan McDonald (Optical spectroscopy)
- Val and Sputnik team (Sample machining)
- M. Switzer/ Joe Mach and STAR lab (Assembly)
- Greg Gonzales (Final machining)
- F. Panerai (CT scans)
- Craig Burkhard (Material acquisition)
- D. Ostrowski (Final prep)
- Jose Chavez (Laser scans)

QUESTIONS?

Backup

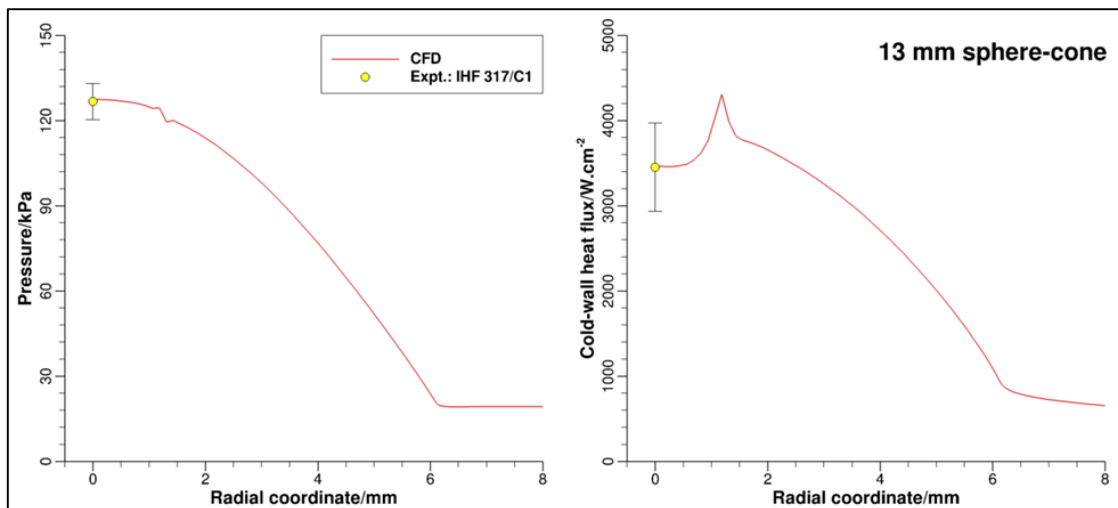

Figure 5.1: Measured pressure and heat-flux values in the facility and comparison with CFD simulations.

Post-test Samples

- Basalt and Campo Del Cielo completely melted during exposure
 - Melt deposits on the graphite and copper cones will be used for further analysis
- A thick fusion crust formed on Tamdakht samples. Laser and CT scans were performed after the test.
 - The melt will be analyzed in near future

