

TRANSIENT MODELING OF LARGE SCALE INTEGRATED REFRIGERATION AND STORAGE SYSTEMS

27th International Cryogenic Engineering Conference and
International Cryogenic Materials Conference 2018
ICEC27-ICMC2018
Oxford, United Kingdom, September 3-7, 2018

Adam M. Swanger

NASA Kennedy Space Center
Cryogenics Test Laboratory
KSC, FL 32899 USA



INTRODUCTION

- In 2015 CryoTestLab engineers tested a large scale Integrated Refrigeration and Storage (IRAS) system for liquid hydrogen at NASA Kennedy Space Center
 - ❖ 125,000 liters of LH₂
 - ❖ Zero-loss tanker offloads, long duration zero boiloff (ZBO), liquefaction, densification with slush production
- **IRAS** = storage tank + internal heat exchanger + cryogenic refrigeration system
 - ❖ Control via direct addition and removal of thermal energy (heat) as opposed to addition and removal of mass
 - ❖ Full control over the bulk fluid properties anywhere along the saturation curve



Ground Operations Demonstration Unit for Liquid Hydrogen (GODU-LH2)



INTRODUCTION

• GODU-LH2

- ❖ IRAS tank with custom-built internal tubular heat exchanger
- ❖ Linde Cryogenics LR1620 helium refrigerator (390 W or 850 W @ 20 K with and w/o LN₂ precooling)
- 3x temperature rakes to map hydrogen temperature profile, 20 total silicon diodes
- Redundant pressure transducers
- Successfully tested at 4 different fill levels: 33%, 46%, 67% & 100%
- **Excellent data for anchoring analytical models!**

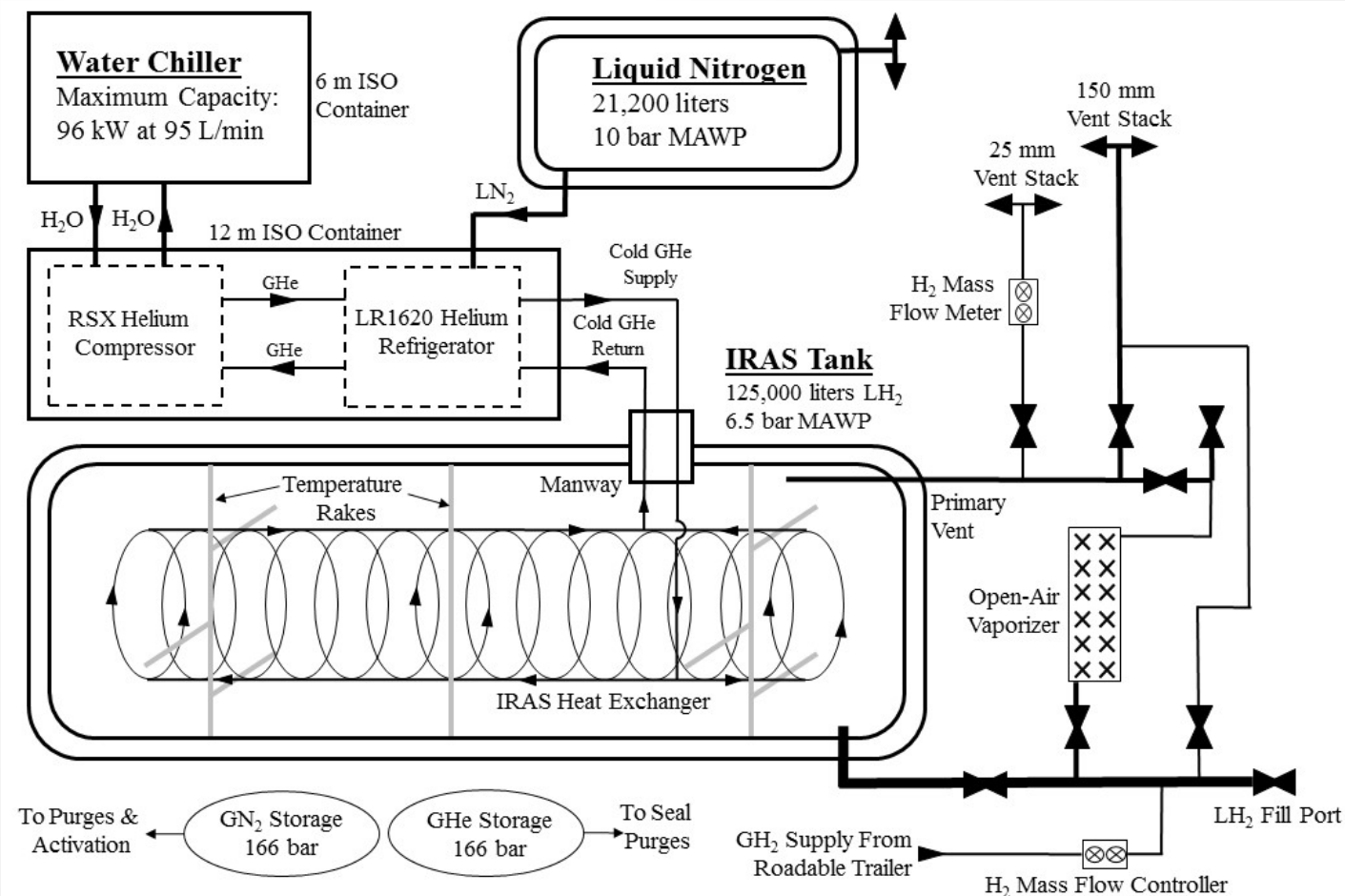

INNER TANK INSTRUMENTATION

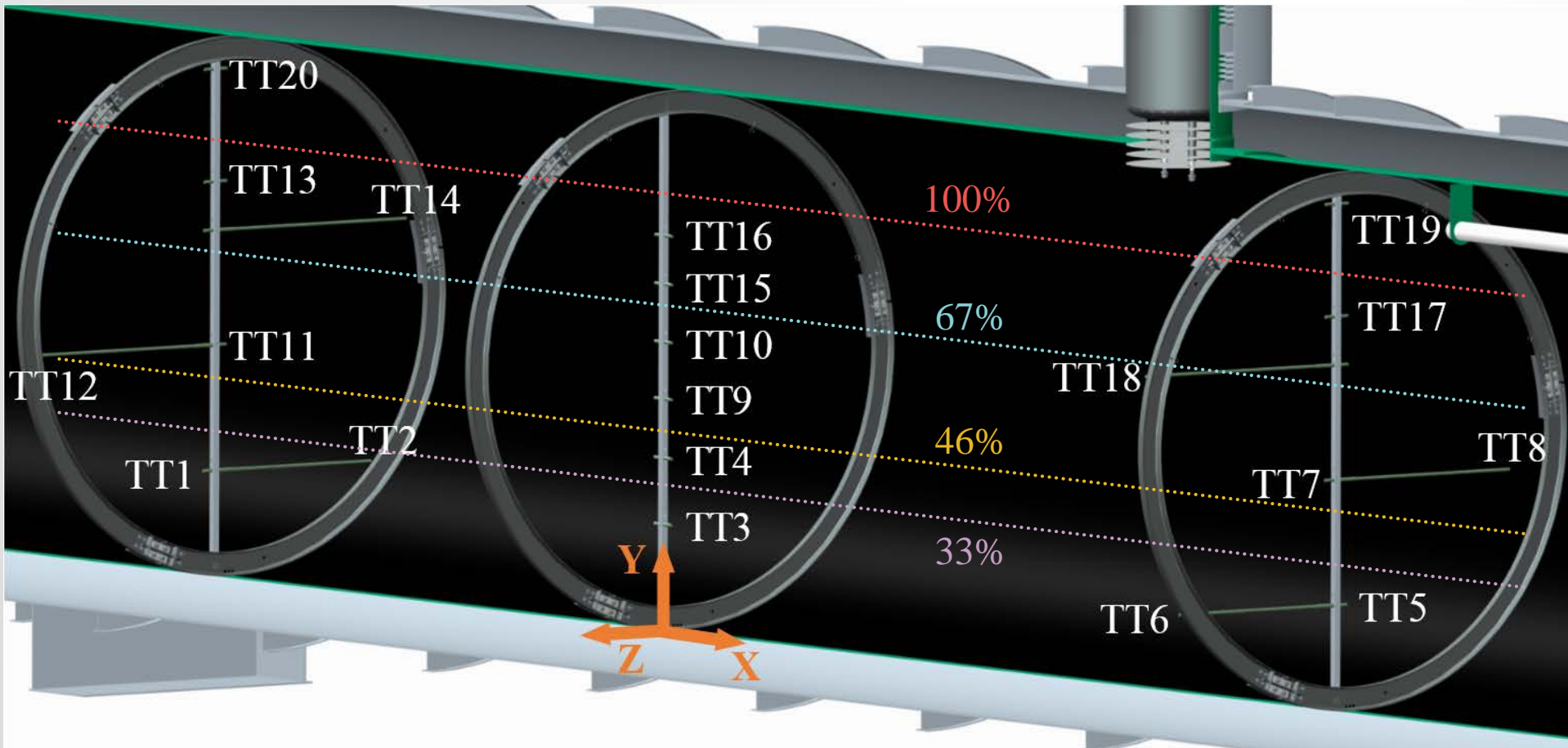

Elevations	
TT3	0.57 m
TT4	0.92 m
TT9	1.24 m
TT10	1.54 m
TT15	1.85 m
TT16	2.12 m
TT20	2.72 m

Accuracies

Diodes: ± 0.5 K from 450 K to 25 K, and ± 0.1 K from 25 K to 1.5 K
 Transducers: ± 6.89 kPa (1% of full scale)



TRANSIENT DATA SET

- Particularly interested in predicting the hydrogen temperature and pressure trends during transient periods
- Densification test data at three different fill levels was used to anchor analysis
 - ❖ Closed tank (no mass exchange)
 - ❖ Depressurization and temperature drop as heat is removed
 - ❖ Specific regions chosen for consistent and uninterrupted refrigerator operation

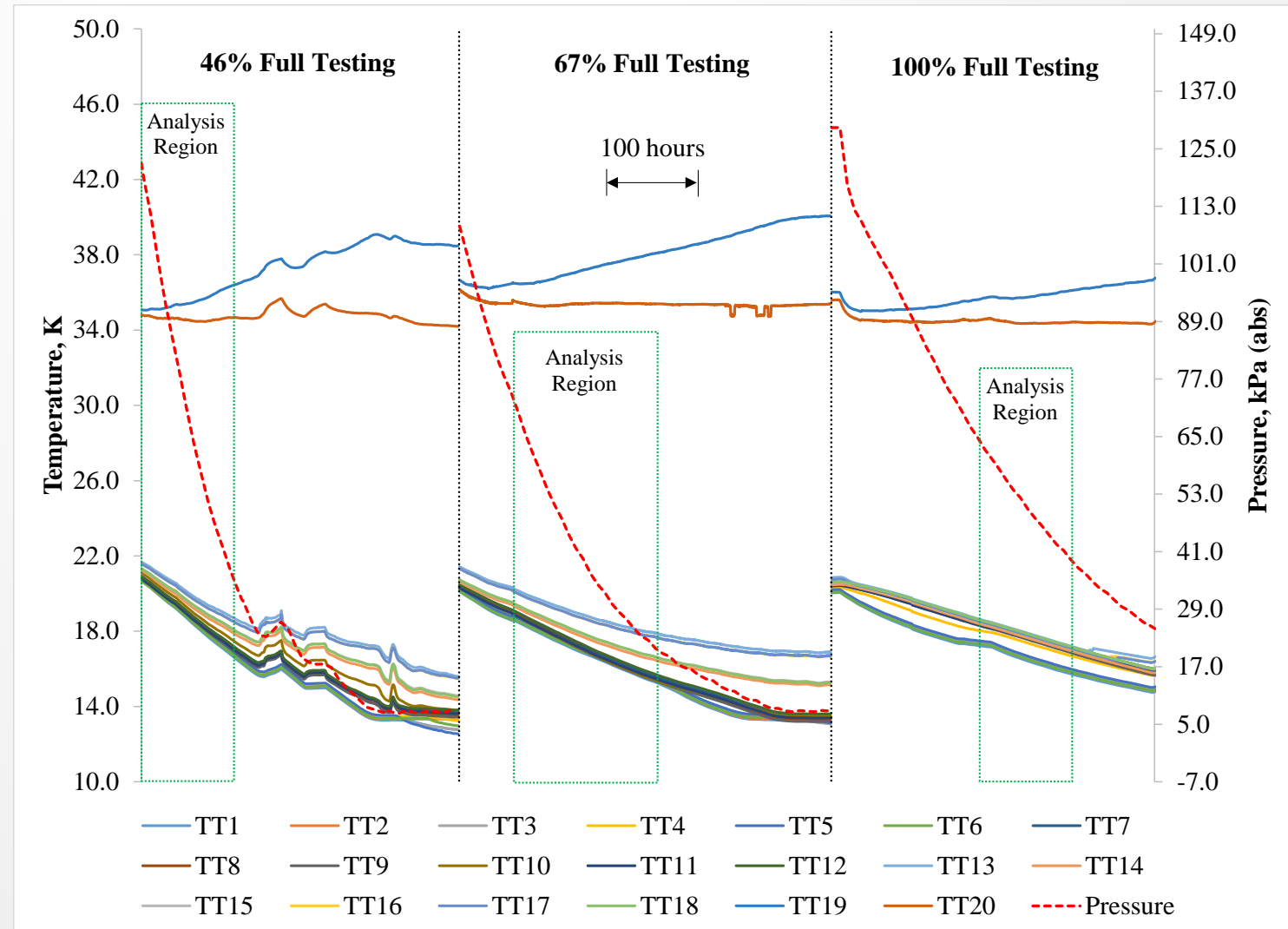

TRANSIENT MODELS

- Two different models were developed, based on two different high level assumptions

1. The entire tank, both liquid and vapor, was fully **saturated** throughout the test

- ❖ Simpler scheme, first one developed
- ❖ Hydrogen properties could be defined by just one parameter
- ❖ Temperature and pressure of the liquid and vapor would be equal



Useful convergence parameter

2. The bulk liquid was **subcooled**, with a finite layer of saturated liquid separating it from the saturated vapor

- ❖ Evolved from saturated model at 100% fill level
- ❖ Saturated layer suppressed heat transfer, slowing depressurization rate
- ❖ Refrigerator lift cooled the bulk liquid below the boiling point → heat transfer through the layer
- ❖ Entire HX was submerged

TRANSIENT MODELS

Model Similarities

- ❖ Lumped node, forward stepping in time
- ❖ Constructed in Excel, utilizing Visual Basic & RefProp v8
- ❖ Any tank volume, geometry, or stored fluid
- ❖ Constant and variable GHe inlet properties
- ❖ All lift took place in the liquid region
- ❖ GHe outlet temp from HX equaled the LH₂ temp
- ❖ 15 minute time increments
- ❖ Heat leaks constant

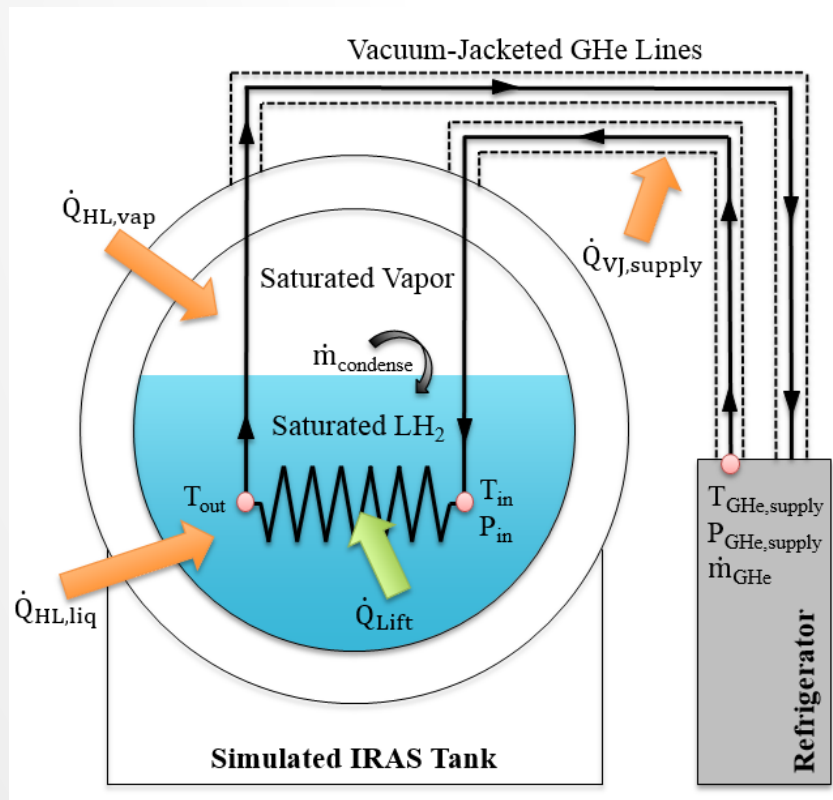

Saturated Model

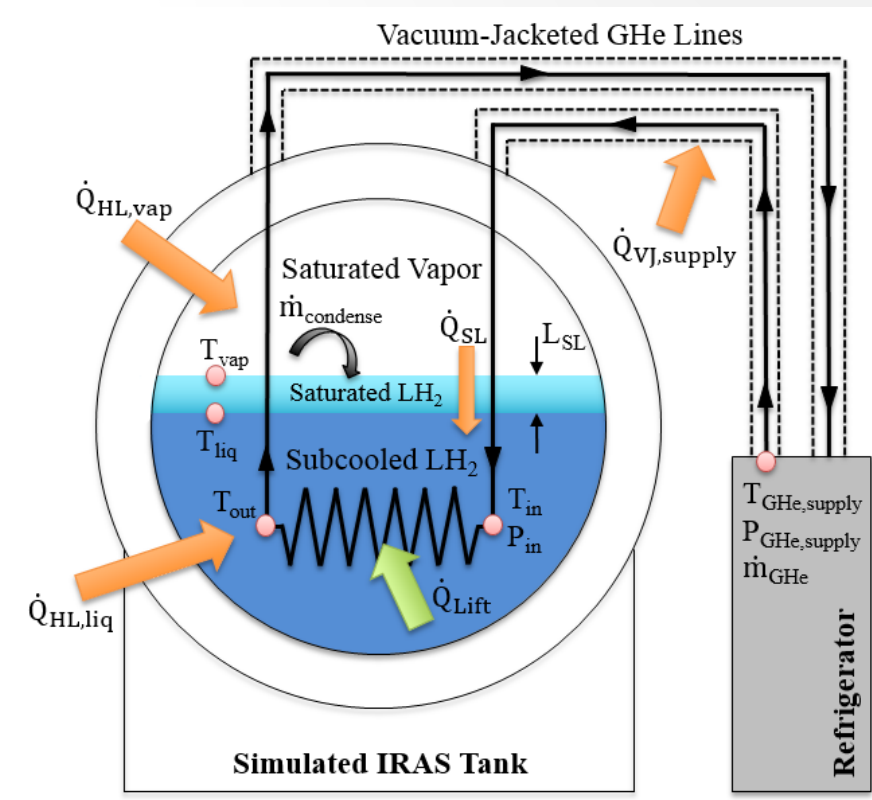

Subcooled Model

$\dot{Q}_{VJ,supply} \rightarrow$ from different analysis (36 W)

$\dot{Q}_{HL,vap} \& liq \rightarrow$ from boiloff calorimetry of IRAS tank (function of fill level)

SUBCOOLED MODEL DETAILS

- Assumed pure solid conduction through the saturated liquid layer
- ΔT across the layer, but constant nodal temperatures for subcooled LH₂ & vapor

How is L_{SL} determined?

- L_{SL} estimated by equating heat transfer into the vapor and through the layer during steady state $\rightarrow |\dot{Q}_{SL}| = |\dot{Q}_{HL,vap}| = \frac{\lambda_{SL} A_{LV}}{L_{SL}} (T_{vap} - T_{liq})$
 - ❖ 100% fill level ZBO-PC data used
 - ❖ A_{LV} estimated from tank geometry and liquid level ($A_{LV} \approx 45.5 \text{ m}^2$, assumed constant)
 - ❖ $L_{SL} \approx 35 \text{ mm}$ (assumed constant)

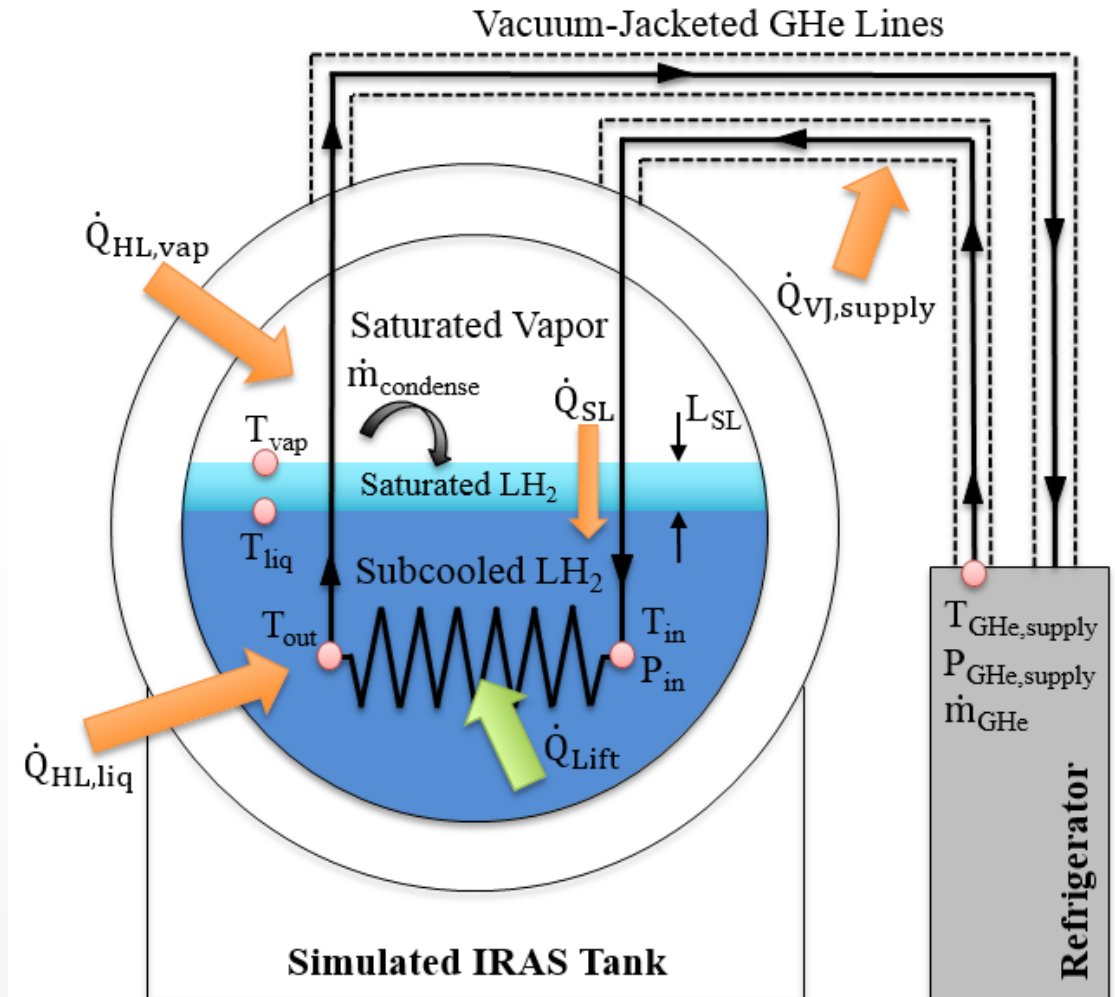

SATURATED MODEL RESULTS

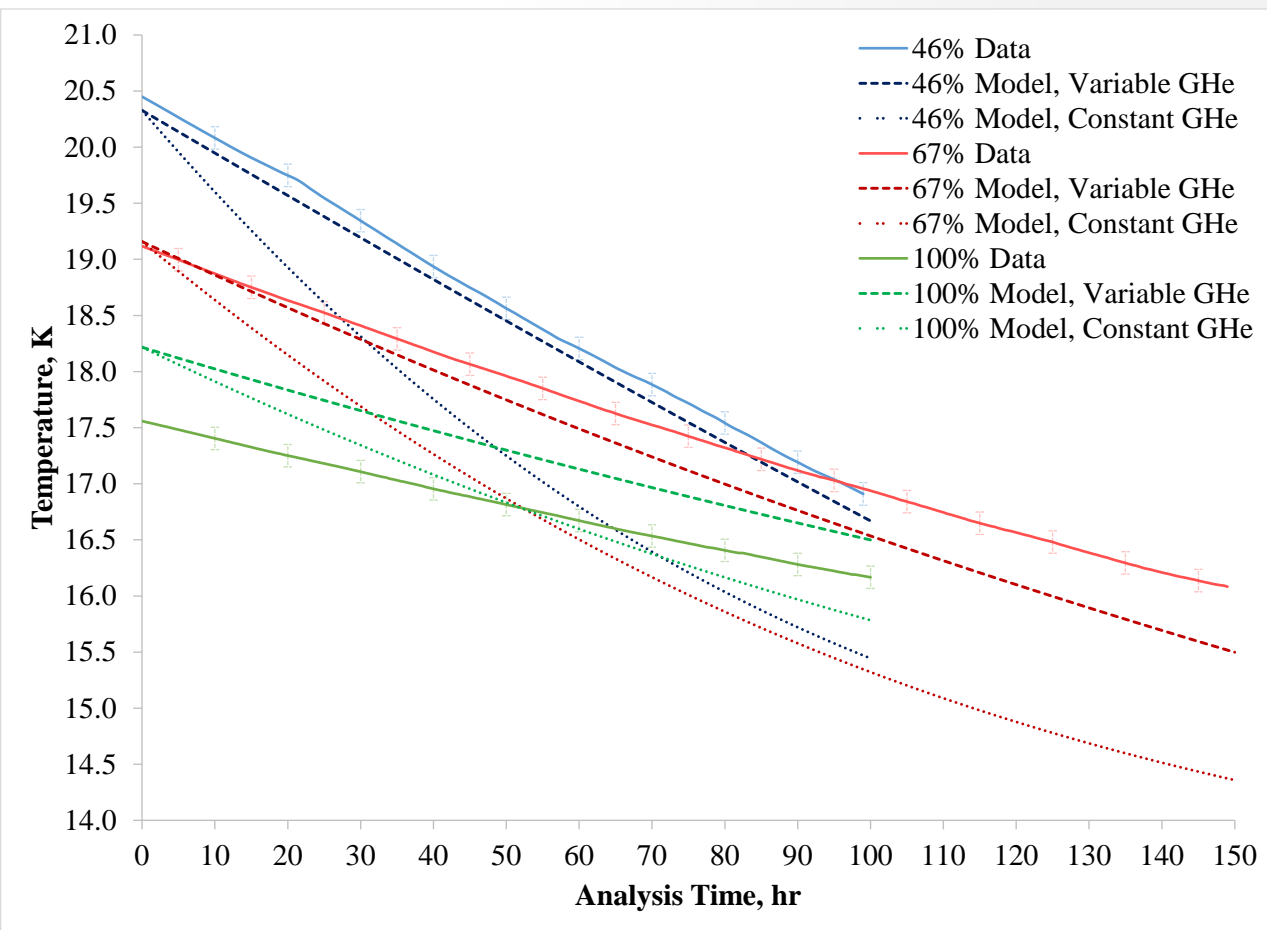
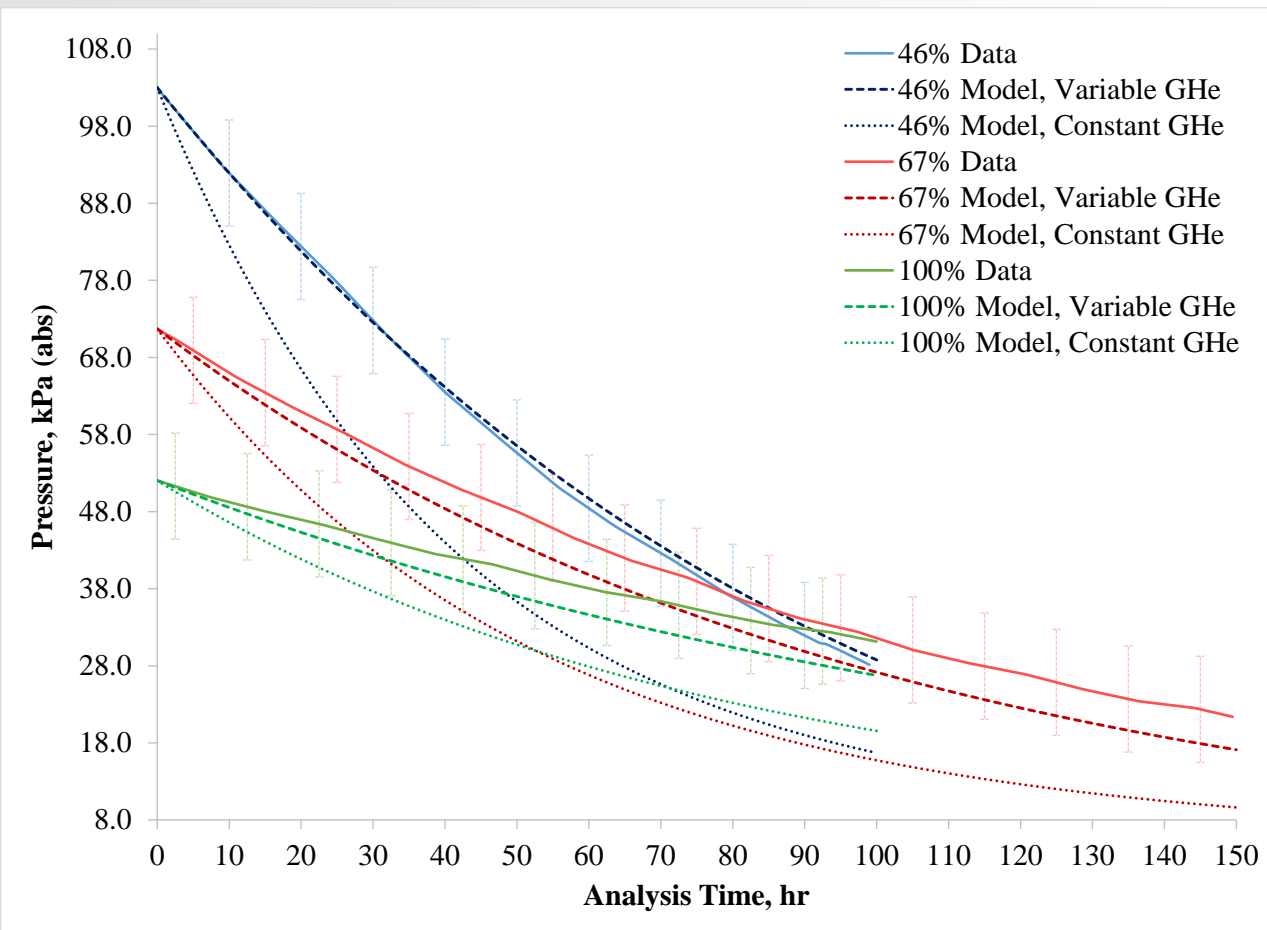

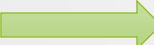
- Good prediction at 46% full for variable GHe properties!
- Constant GHe properties is probably a bad assumption
- Tank not saturated at 100% full  **Subcooled model**



SUBCOOLED MODEL RESULTS

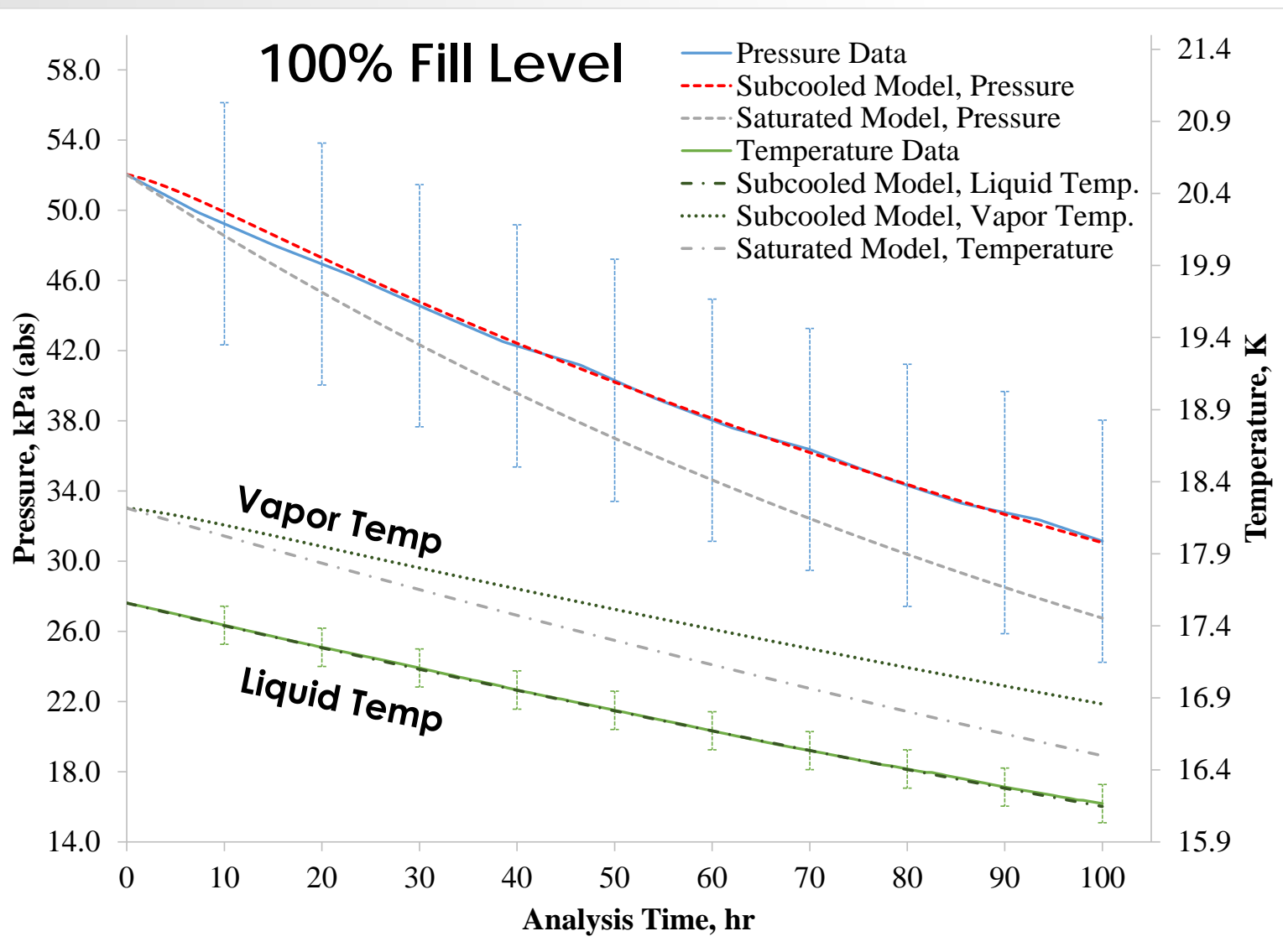

- Only variable GHe properties shown
- Much better prediction of both depressurization & temperature drop!
 - ❖ Avg. ΔP between data and model = -0.06 kPa
 - ❖ Absolute temperature error = 0.03%
- Model also run at 67% full
 - ❖ Better accuracy than saturated model, but still less than other fill levels

DISCUSSION & TAKE-AWAYS

- Results appear to suggest that the tank was fully saturated at lower fill levels, but deviated as the liquid level increased → **function of the unique GODU-LH2 system, or more fundamental?**
 - Is it, or can it be affected by heat exchanger design, refrigerant flow path, tank geometry, fluid species, etc?
- Both models closely predicted the transient data, but was dependent on fill level → **is a generalized “universal” scheme possible?**
- Approaches seem to be applicable to any scale IRAS system, but some information is required *a priori* → **heat leak estimations, refrigerator performance numbers, etc.**
- Good basis for future examinations, but **more experimental testing and analytical study is necessary!**



THANK YOU FOR YOUR ATTENTION!

QUESTIONS?



Storm clouds over GODU-LH2 test site
June 2016

