

# Uncertainty Analysis of Coaxial Thermocouple Calorimeters used in Arc Jets

Dave Driver, Daniel Philippidis, Imelda Terrazas-Salinas

## Outline

- What is a Coaxial Thermocouple Calorimeter
- This will describe a conduction analysis of heat transfer internal to the calorimeter probe
- Bias errors are encountered when a 1D Finite Slab inverse analysis is used to deduce heat flux from the temperature measured at the nose of the calorimeter
- This paper quantifies the bias errors for a number of calorimeter probes and offers an analysis that will minimize these errors

# Motivation

- Heat flux is the primary measurement of interest in arc jet testing
- Heat flux can be measured a number of different ways
- Most devices measure the temperature rise of a mass of copper
  - Temperature measured on the backside of the calorimeter (thin-skin, and slug calorimeters)
  - Temperature measured near the **front side** of the calorimeter (Null Point, **Coaxial Thermocouple**)
- Coaxial thermocouples are just one means of measuring surface temperature
- **Different types of calorimeter occasionally give different answers**
- Which begs the question, what is the truth?
- The Coaxial Thermocouple calorimeter is frequently used for flow field surveys
- Can the Coaxial TC replace the slug calorimeter for absolute measure of heat flux

# 102mm Hemi Heat Flux Measurements with Various Sensors

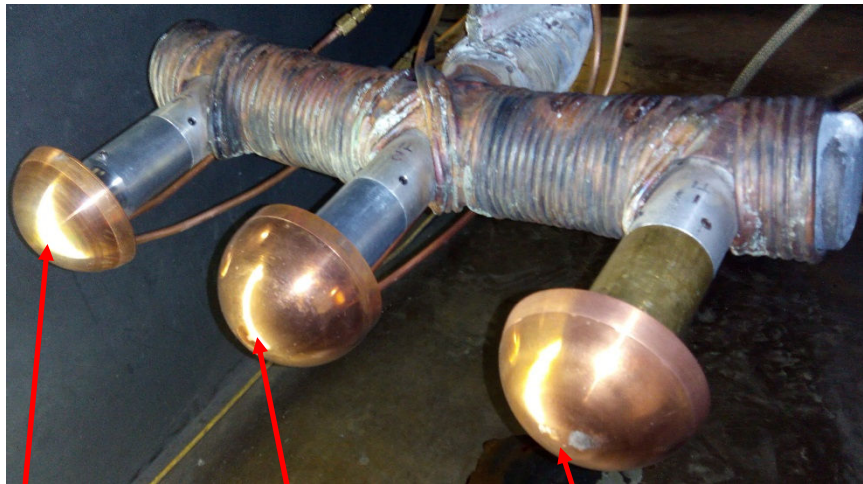

Null Point      Gardon Gage      Coaxial TC

4" Hemi with  
Pressure tap and  
temperature sensor

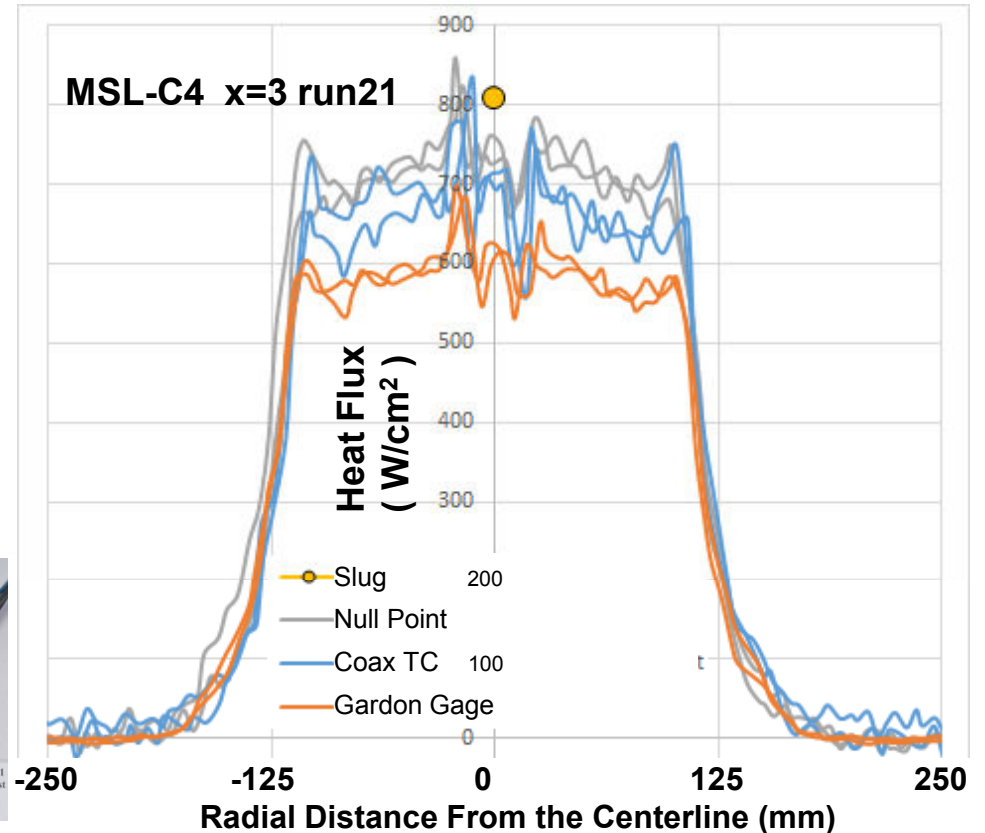

## Fast Response Sensors (Null Point, CoaxTC, Gardon Gage)

- Coax TC is in the middle of the range of possible measurements
- Null Point measuring +7% higher than the Coax TC
- Gardon Gage measuring -13% lower than the Coax TC
- Slug measuring +15% higher than the Coax TC
- Coax, NullPt & Gardon give similar shaped radial distribution of heat flux

# Slug Calorimeters

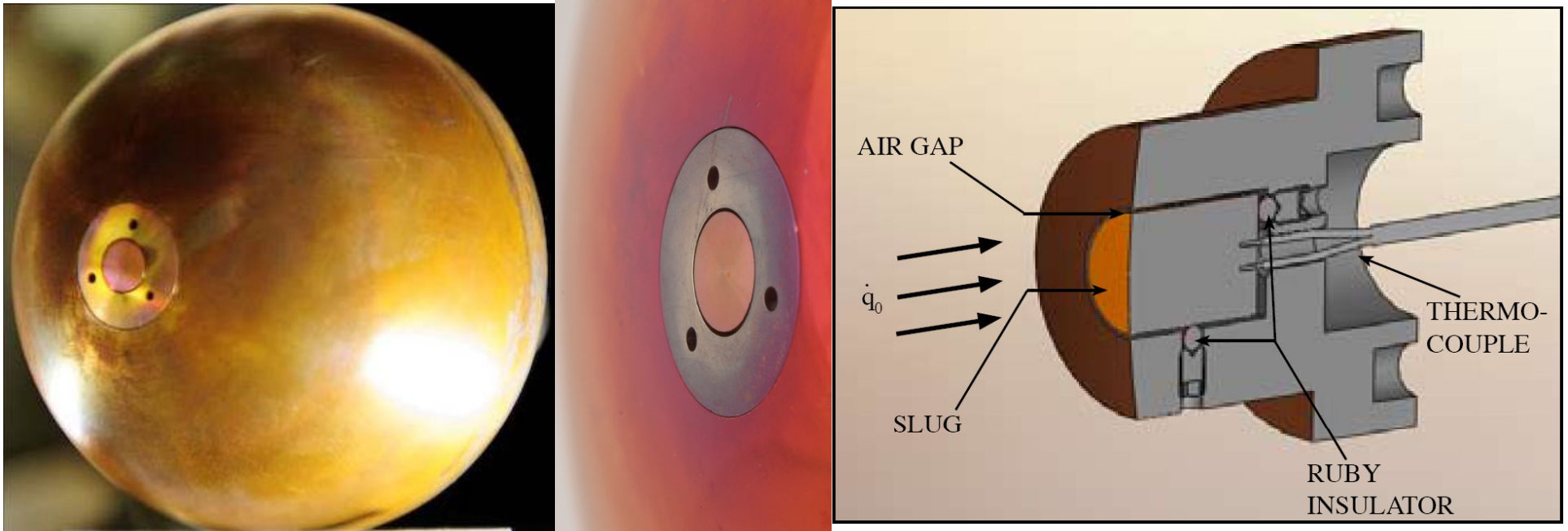

- Slug Calorimeters have been the gold standard for five decades.
- Why question them now?
- Conduction (losses) through Ruby ball insulators ( usually less than 5%)
- Heat flux (gain) through air gap heating of side of slug (unknown gain).

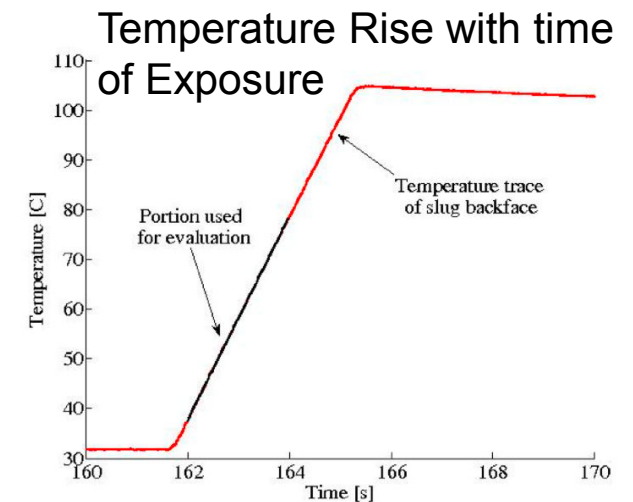

# CoaxTC Sensor

A Rapid Response Heat Flux Sensor

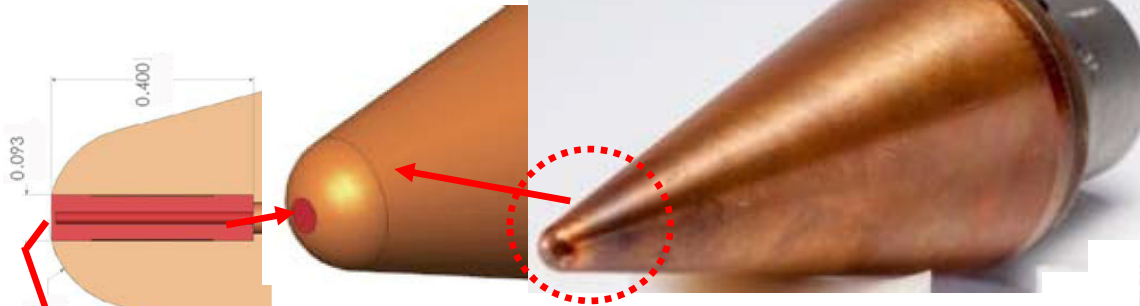

Coax TC Artist Rendition

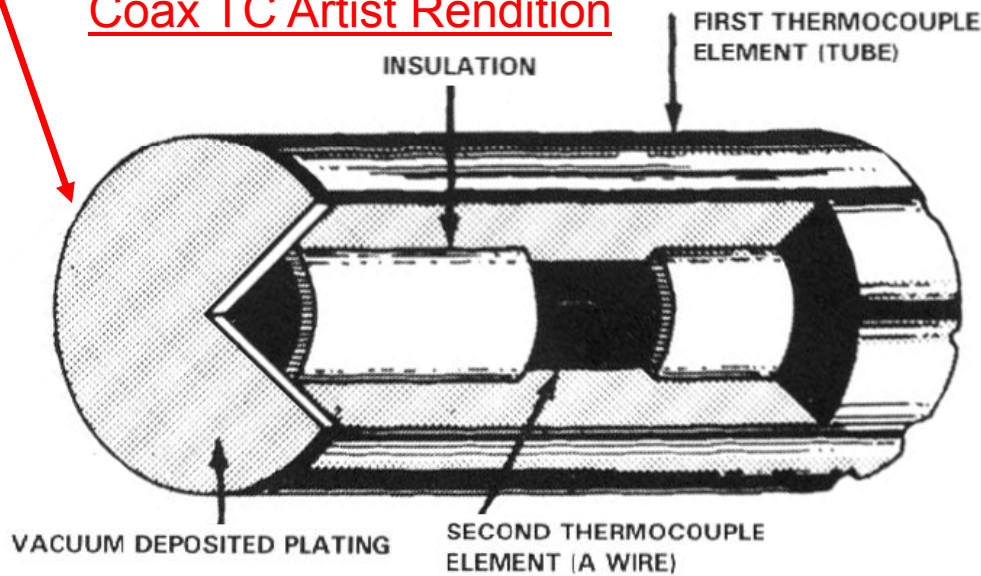

**Medtherm CoaxTC** Bulletin 500 *COAXIAL SURFACE THERMOCOUPLE PROBES*  
 One thermocouple element (a tube) is swaged over the second element (a wire) with 0.0005" thick insulation between the elements. The Thermocouple junction is formed by a vacuum deposited metallic plating across the sensing end of the assembly. (Artist's rendering shows thickness of insulation and metallic plating exaggerated in size.)

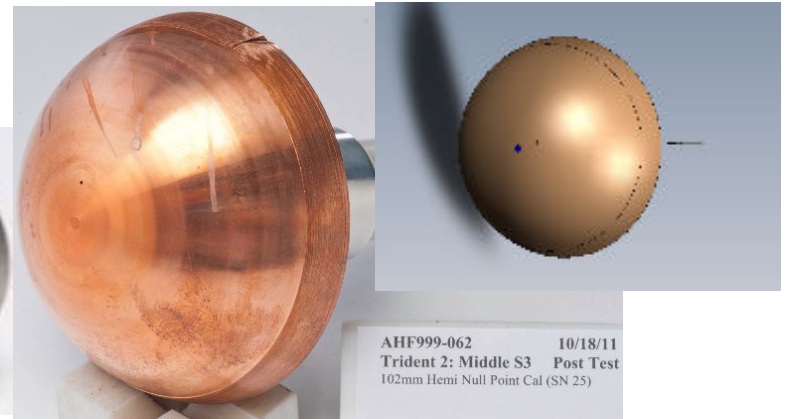

Coax TC Schematic

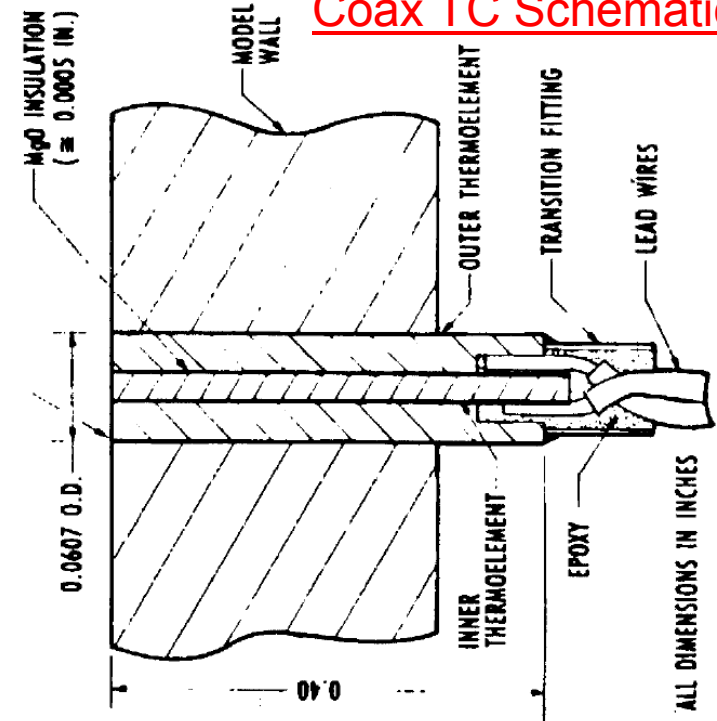

**AEDC CoaxTC** NASA1992CP\_3161Kidd  
 The three component unit (Wire, InsulationMgO, tube) is drawn down from 0.125" to 0.067" with the possibility of going as small as 0.015". The hot junction is completed by abrading the center conductor and outer tube together with #180 grit emery paper.

Fig. 9. Sketch of coaxial surface thermocouple

# Why Coaxial Thermocouple Calorimeter

- Coaxial Thermocouple calorimeter probes do not have a gap between the sensor and the calorimeter body into which they are mounted.
- Coaxial TC truly measures the surface temperature (without gimmicks)
- The Null Point uses a backside bore hole at the end of which is a TC.
  - The center of the webbing somewhat mimics the surface temperature of a slab without a hole.
  - But not truly a surface measurement.
  - Over prediction of heat flux due to missing material.

## Possible Issues with Coaxial Thermocouple Probes

- Underlying assumption is that the heat conduction into the probe is 1D in nature and can be analyzed as a finite slab with inverse techniques
- Most calorimeter probes have a spherical nose rather than a planar slab
- Secondly the heat flux over the face of a spherical nose is not uniform
- Surely there are 2D effects, but how significant are they.

# Study of 2D Effects

## Approach

- Simulate the heat conduction within various Calorimeter geometries
- Include any non-uniformities in surface heating (predicted by CFD)
- Obtain the surface temperature history at the nose of the calorimeter
- Given the surface temperature history, use “1D” inverse methods to deduce the heating at the nose of the calorimeter body.
- Difference in deduced heating rate and imposed heating rate is the bias error due to 2D effects
- Improve the inverse analysis where possible to reduce the errors
- This paper has very little to do with the Coaxial Thermocouple itself but is more about the heat conduction within a spherical shell
- The majority of the paper assumes the Coaxial TC is an integral part of the shell

# Error Analysis with ANSYS Conduction Analysis

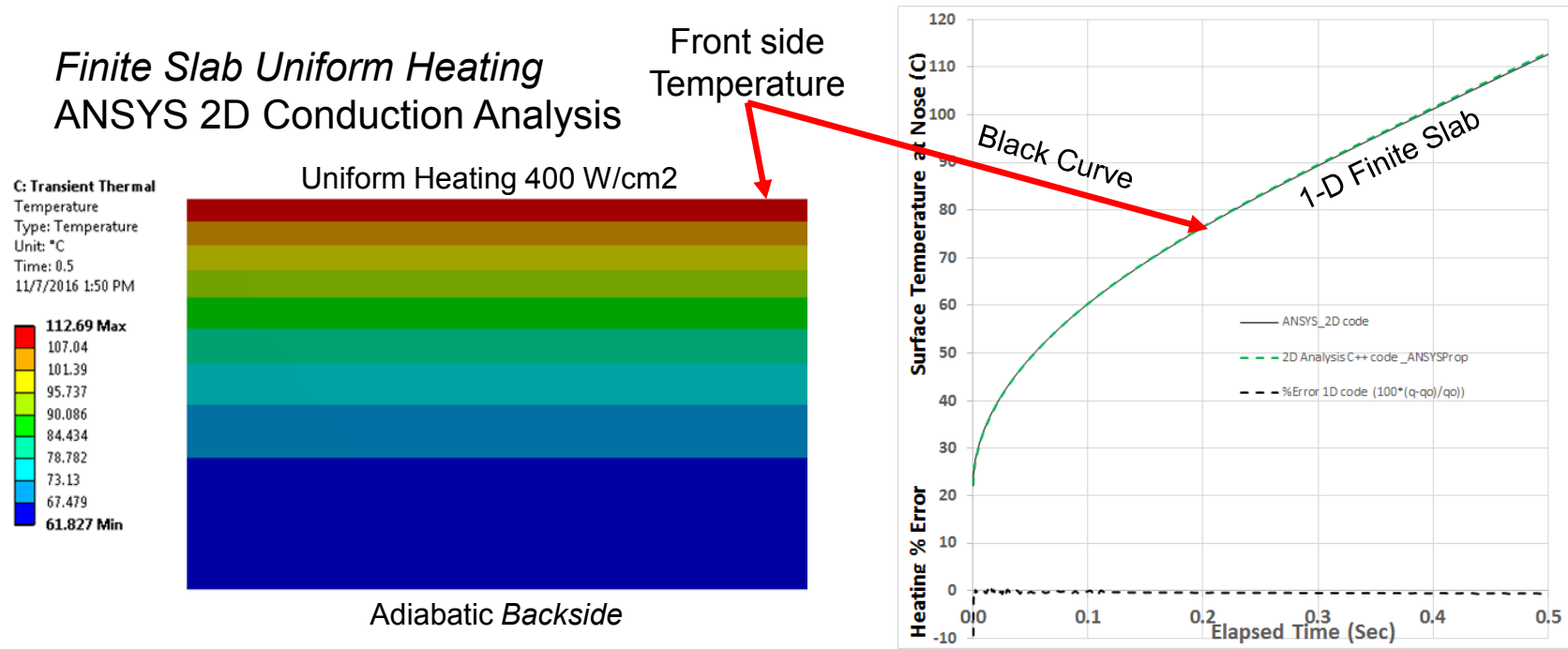

- 2D/3D Finite Slab transient conduction simulated by ANSYS (Black Line)  
D.Driver's 2-D Finite Slab finite difference Conduction analysis code agrees with ANSYS (Green Line)
- Using surface temperature predicted by ANSYS code  
run an Inverse Solver which solves for heat flux as a function of temperature  
0% error (Heating rate difference between ANSYS and inverse solver)
- Good Agreement (0% Heating rate difference between ANSYS and inverse solver) black line
- One issue is that most calorimeters are not flat slabs – they are curved shells



# IsoQ Conduction Analysis

## Compared to Finite Slab Conduction Analysis

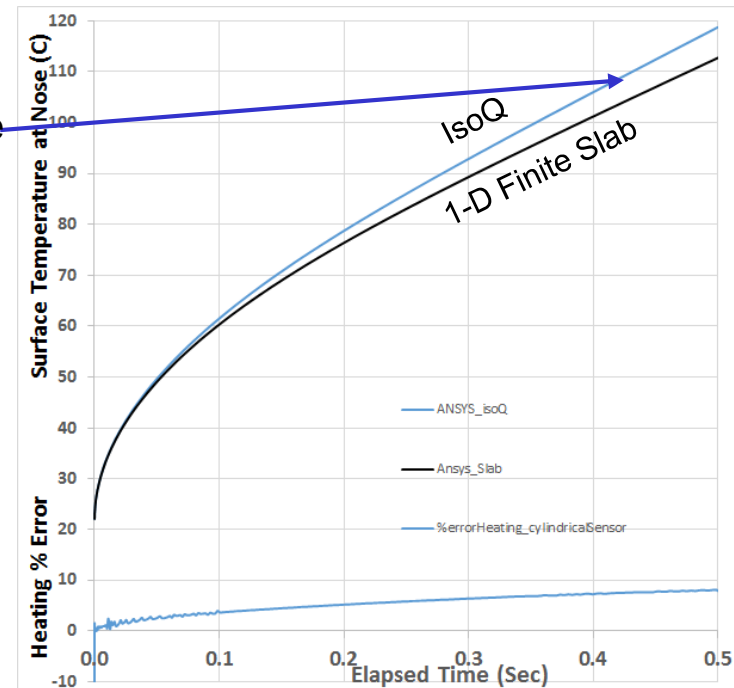
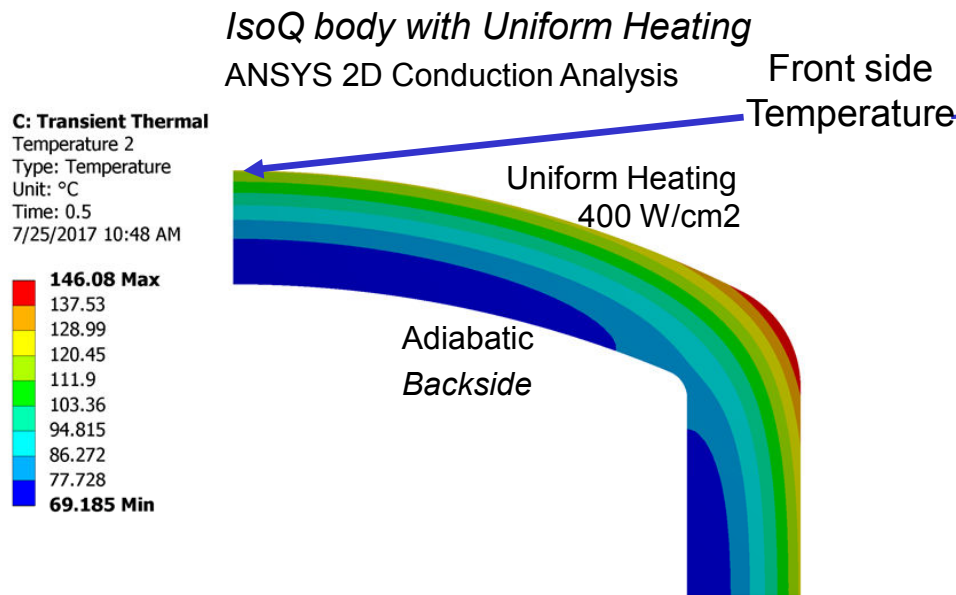

- Here the heating is prescribed to be a uniform (400 W/cm<sup>2</sup>) everywhere on the outer surface
- The ANSYS simulation shows that temperature isotherms follow surfaces of concentric spheres ( $r=\text{constant}$ ) across the inner third of the calorimeter, much like the model problem of a uniformly heated spherical shell.
- The IsoQ body heats up faster than does the semi-infinite slab.
- As a result, the planar 1D finite slab inverse code, overestimates the heating at the nose when given the ANSYS derived temperature history. (see blue line near abscissa).

# Spherical Shell Model Problem

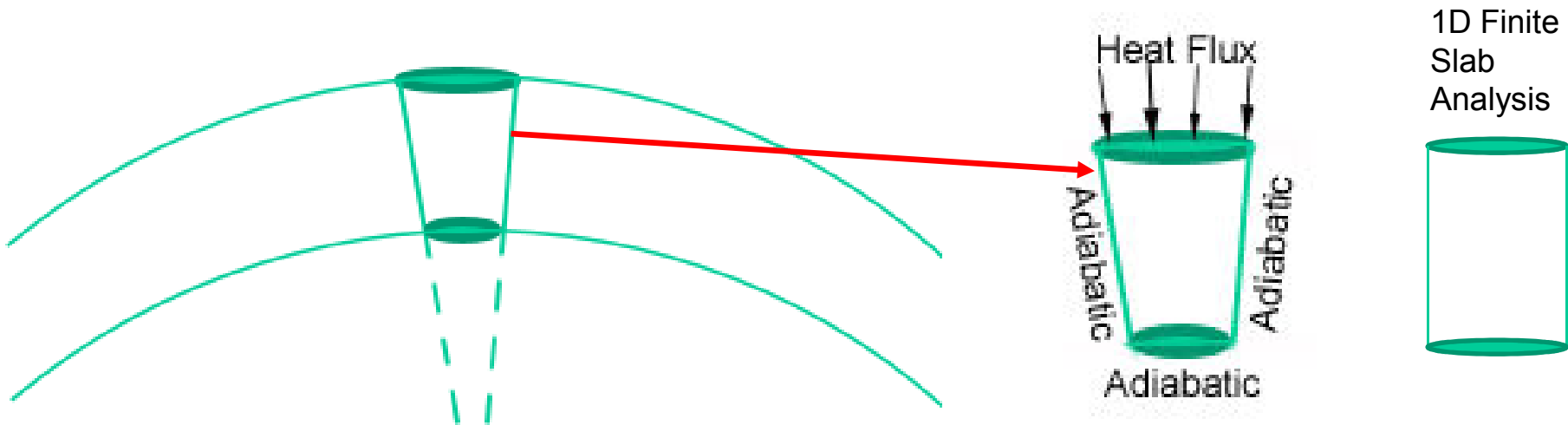

- Consider a conical slice of the spherical shell with sides that are defined by radial lines emanating from the center of the sphere
- Isotherms follow surfaces of concentric spheres, therefore there is no heat transfer across radial lines.
- The boundary condition on the conical frustum like shape is adiabatic everywhere except the outer surface
- The faster temperature rise can be explained by the fact that the areal mass is less in the case of the conic frustum relative to a similar thickness planar slab

# Write 1D Finite Element Code for Conic Frustum

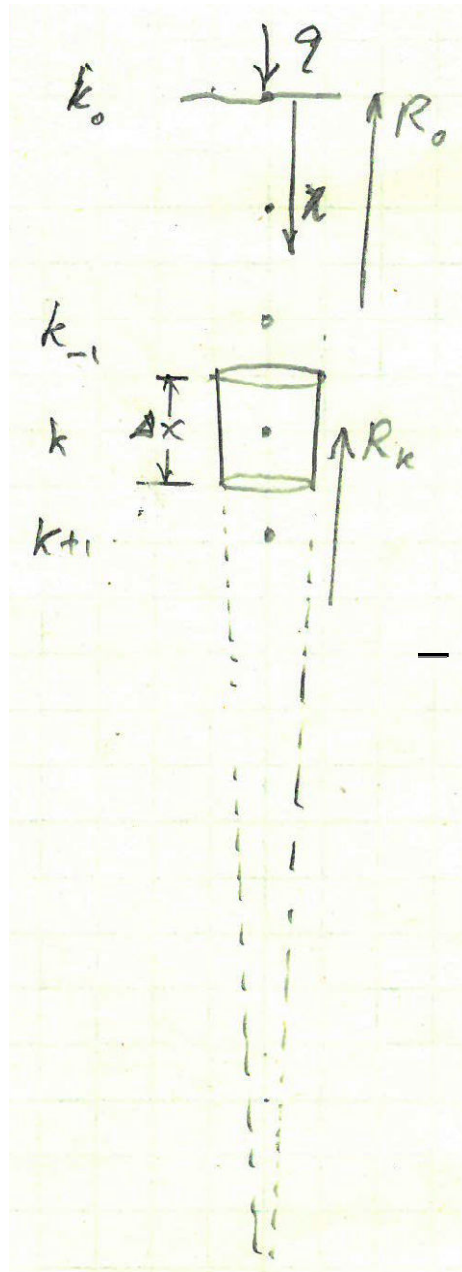

- Rewrite analysis code to incorporate narrowing of the finite element

## Energy Balance about Differential Finite Element

$$\underbrace{-\left(\frac{R_{k+1/2}}{R_k}\right)^2}_{A} T_{k+1}^{n+1} + \underbrace{\left\{ \left(\frac{R_{k-\frac{1}{2}}^2 + R_{k+\frac{1}{2}}^2}{R_k^2}\right) + \frac{\Delta x^2}{\alpha \Delta t} \right\}}_B T_k^{n+1} - \underbrace{\left(\frac{R_{k-\frac{1}{2}}}{R_k}\right)^2}_{C} T_{k-1}^{n+1} = \underbrace{\frac{\Delta x^2}{\alpha \Delta t}}_D T_k^n$$

- When  $(R_o \rightarrow \infty)$  the coefficients A, B, C revert back to the values associated with the typical 1D planar finite slab analysis  $(-1, (2 + \Delta x^2 / \alpha dt), -1)$  respectively)

# IsoQ Conduction Analysis

Corrected for curvature

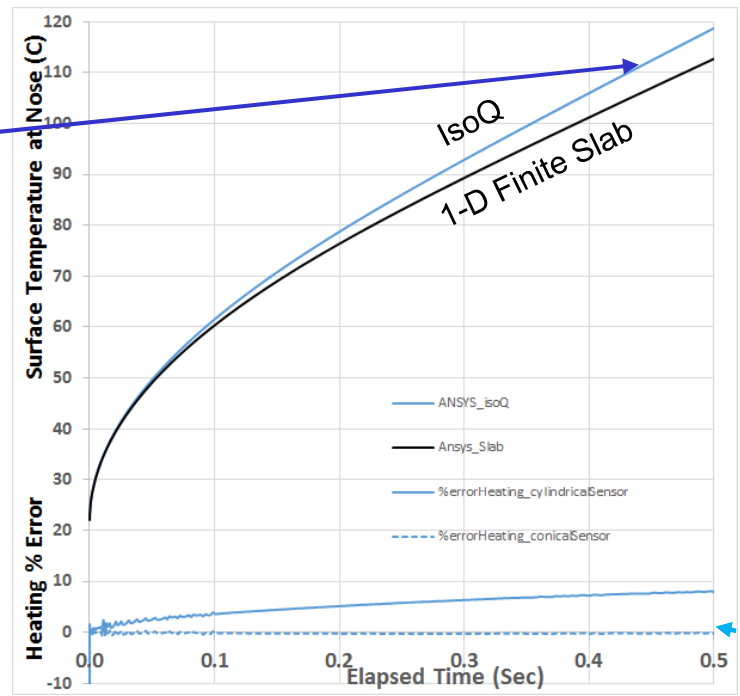
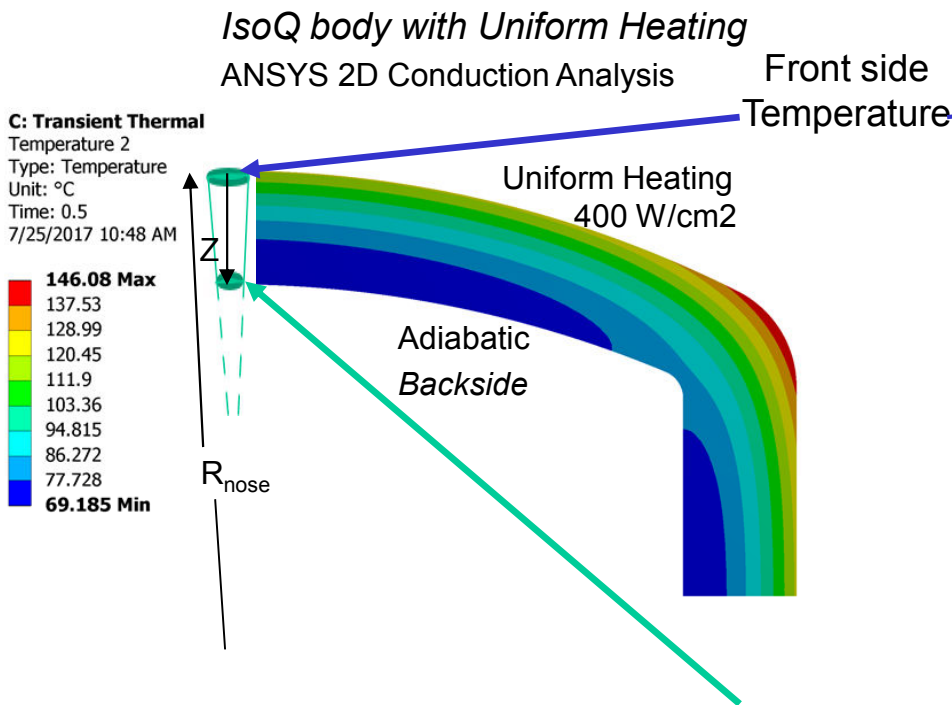

- Modeling the differential slice as a conical shape which narrows with distance in depth allows the modified 1D analysis to give good agreement with the imposed heating (0% error)
- The 1D inverse heat flux analysis on curved bodies might need to include this effect  
The radius of curvature effect can get quite severe as the nose radius gets small
- This doesn't completely solve the problem, there is still an issue with non-uniform heating

# IsoQ Conduction Analysis

Heating Varying Across the Face

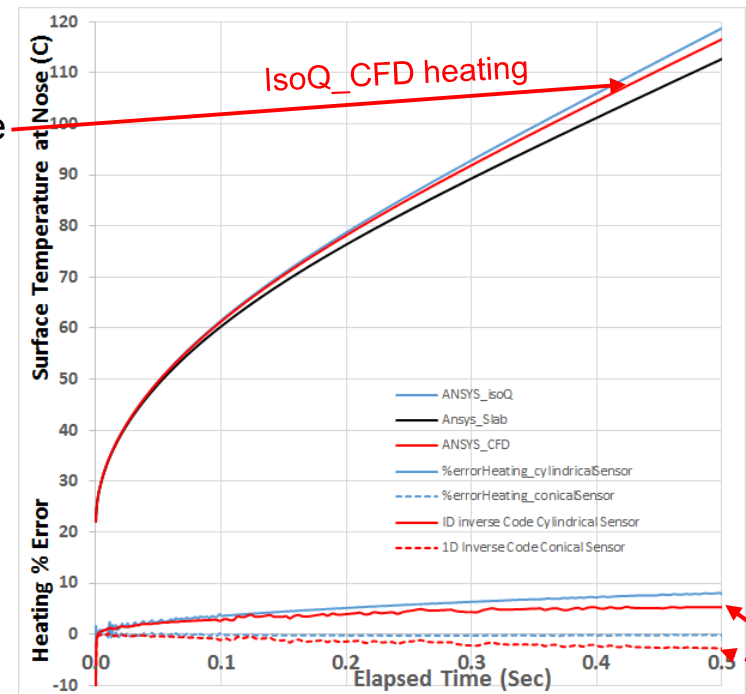
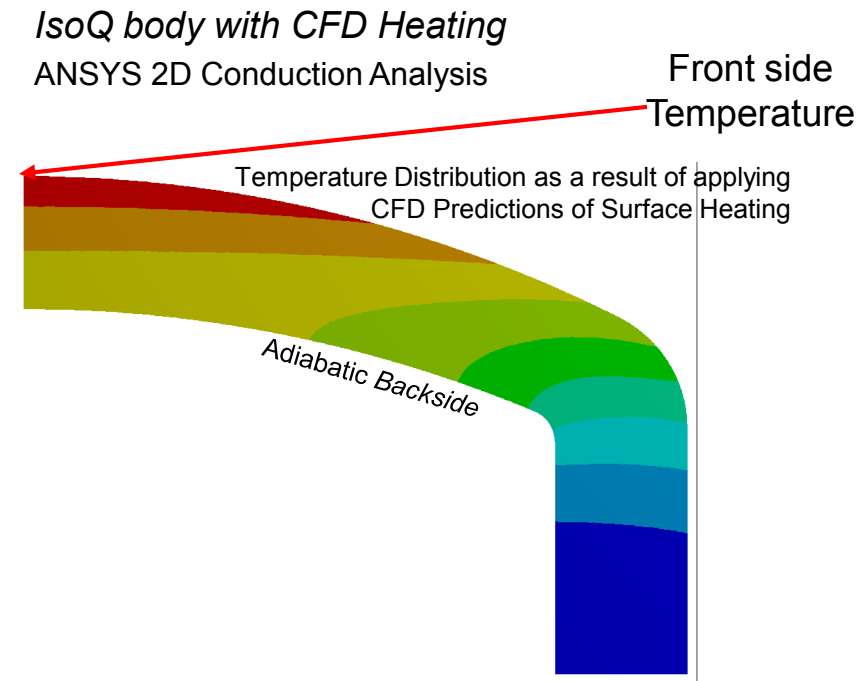

- Imposing the CFD derived heating distribution on the surface of the shell reduces the rate of temperature rise at the nose of the calorimeter
- And reduces the heating rate deduced by both 1D finite element analysis methods
  - 1D Finite Slab
  - Conical Frustum shaped finite element
- Neither model is perfect
- 2D effects are more complicated when the heating is not uniform across the face

# IsoQ Analysis – Longer Exposure

*IsoQ – consider various assumptions*

ANSYS 2D Conduction Analysis (Daniel Philippidis)

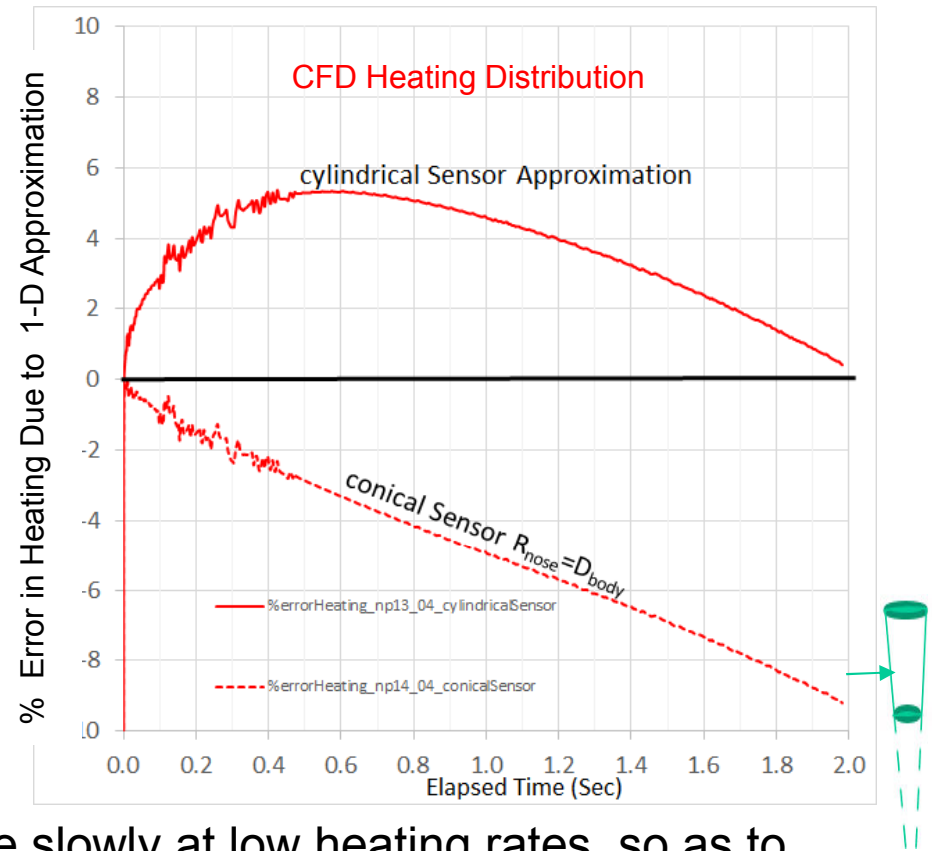
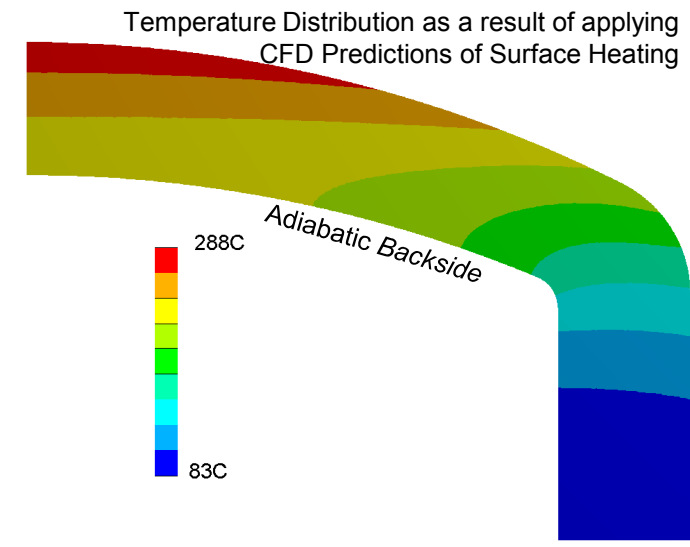

- Occasionally Calorimeters are swept more slowly at low heating rates so as to give a greater temperature rise (more measurable)
- Longer exposure times cause more lateral conduction (to colder outer rim of the body)
- Conical differential slice approximation gives worse results with longer exposure
- What to do

# IsoQ Analysis – Longer Exposure

*IsoQ – consider various assumptions*

ANSYS 2D Conduction Analysis (Daniel Philippidis)

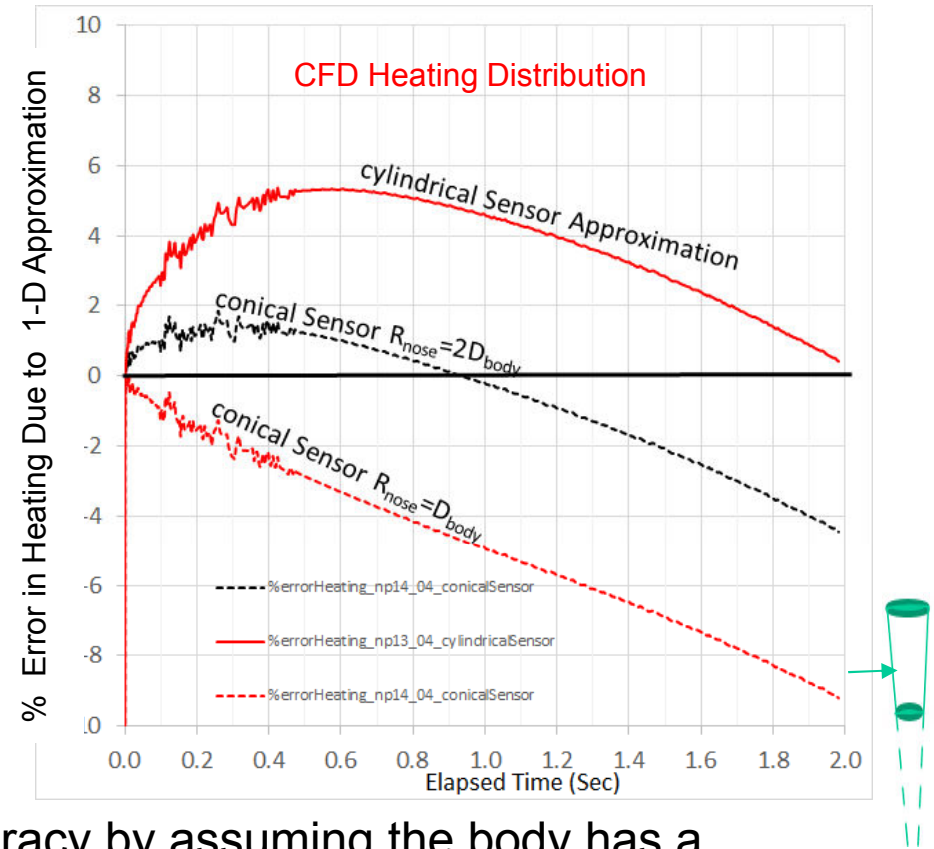
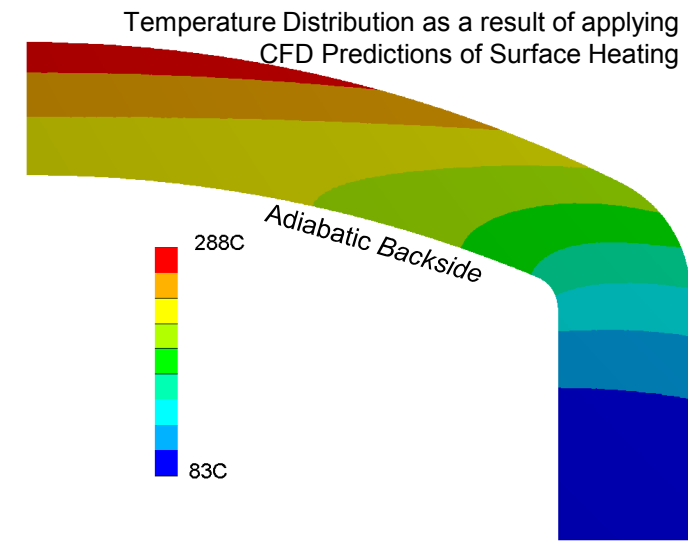

- Possible to eek out slightly better accuracy by assuming the body has a spherical nose radius that is twice that of the actual nose radius
- Ad hoc assumption ( $R_{nose}=2D_{body}$ ) to get a better fit to the data (ANSYS results)
- Next consider other Calorimeter geometries (Hemi and SphereCone)

# 102mm Hemi Calorimeter Error Due to Approximations

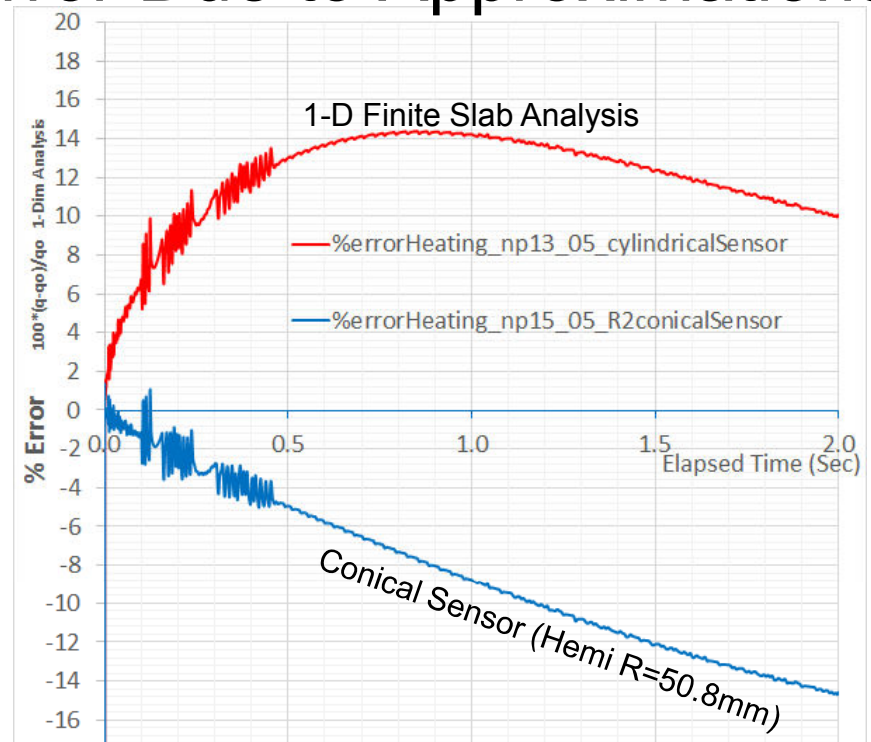
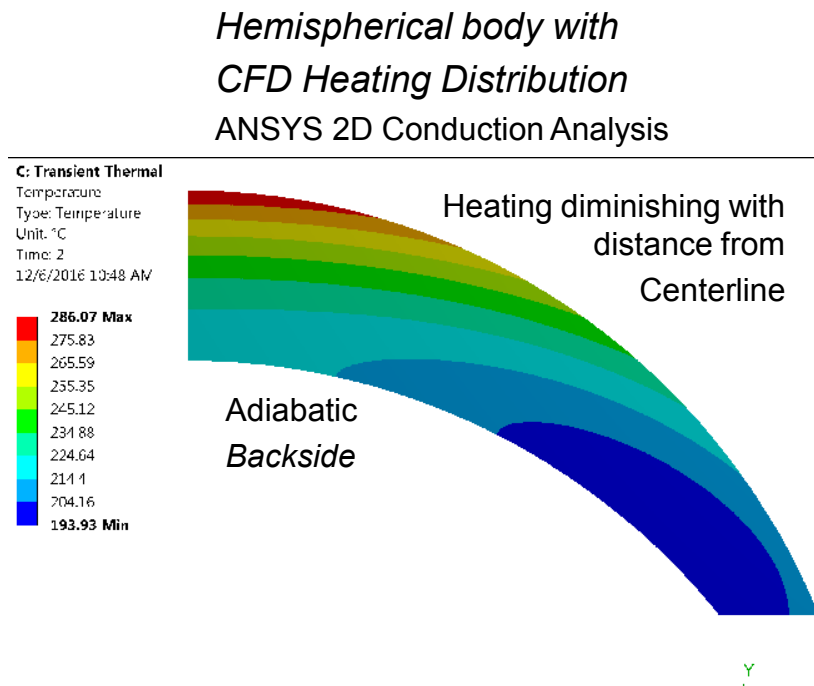

- 102mm Hemi calorimeter Body Simulated in 2D with ANSYS using CFD predicted heating rate across the face of the body (heating diminishing with distance from centerline)
- Resulting Temperature Rise at nose of body is input into 1D analysis codes using
  - 1D Finite slab (in one case) and Conical Frustum Element (in the other case)
- 1-D Finite Slab Inverse Analysis gives as much as 14% over estimate of heating
- Arc Jet data uses 1D Finite slab & is likely to be an over estimate of the heating
- 1-D Conical Inverse Analysis under estimates the heating
- What to do? Can this be corrected?



# 102mm Hemi Calorimeter Error Due to Approximations

## Hemi body with CFD Heating Distribution

ANSYS 2D Conduction Analysis (Daniel Philippidis)

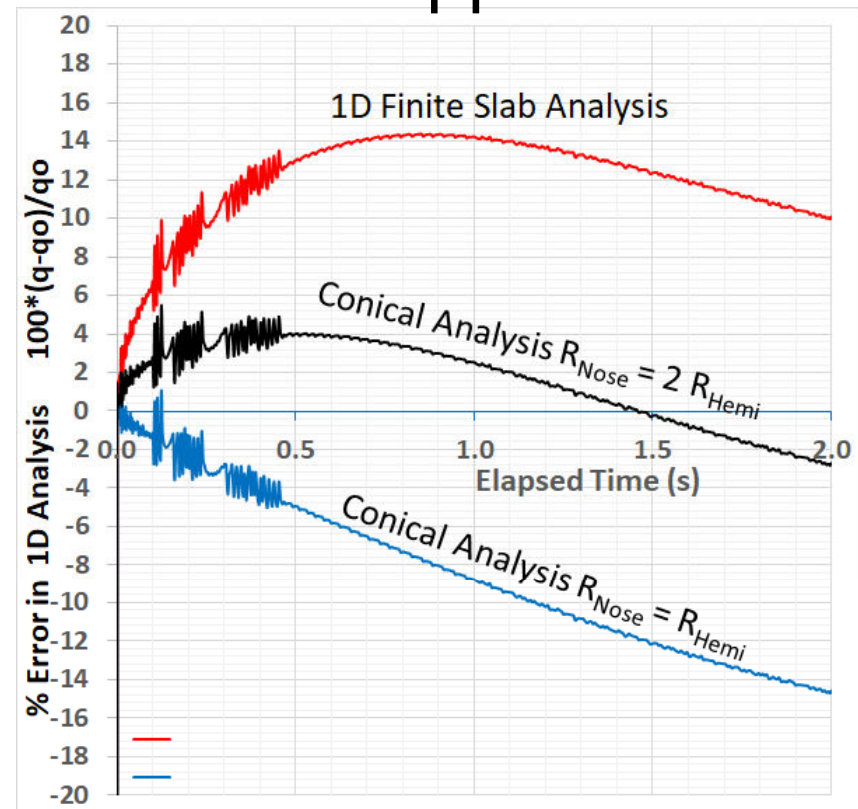
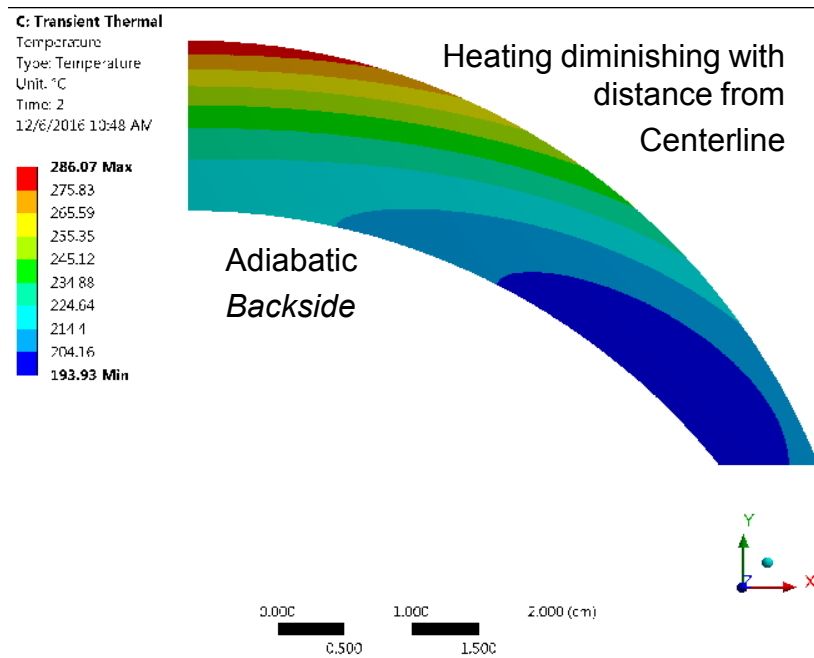

- The actual heating lies between the 1D Finite Slab Analysis and the Conical Analysis
- Ad hoc assumption (*Assume the Nose Radius of calorimeter is twice its actual nose radius*)
- The deduced heating is within 4% of the imposed heating

# 12.7mm SphereCone Body – Errors due to Approximation

*Sphere Cone body with  
CFD heating Imposed*  
ANSYS 2D Conduction Analysis

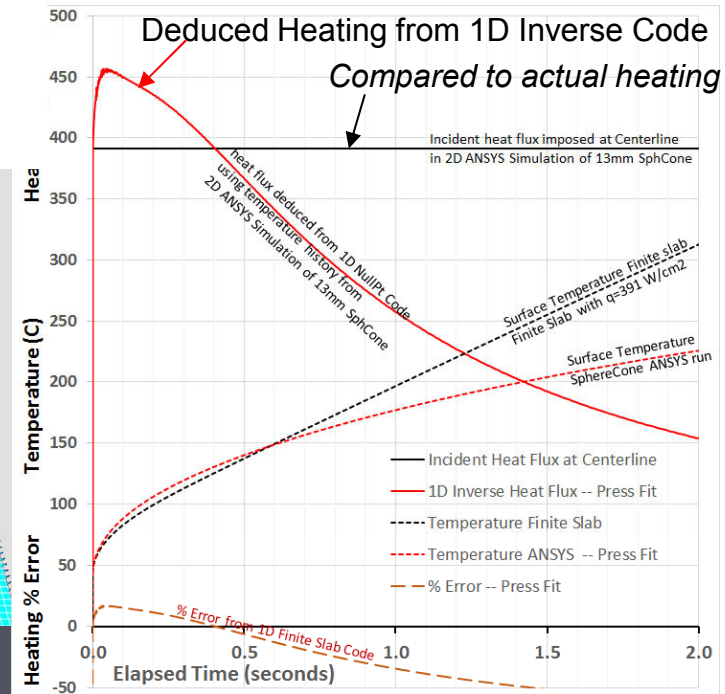
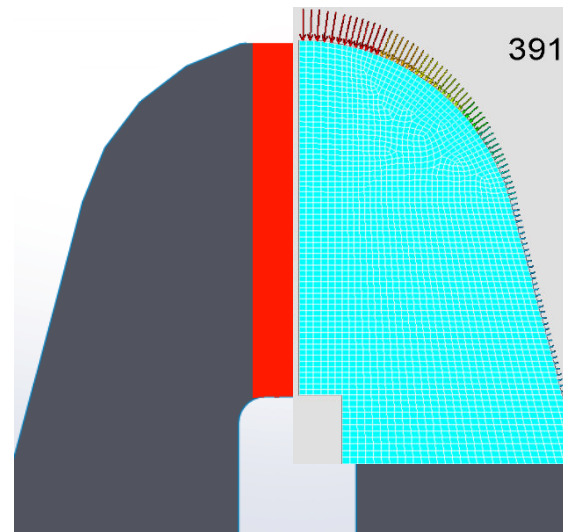

- 12.7mm SphereCone Calorimeter Body Simulated in 2D with ANSYS
  - Imposing a CFD predicted heating distribution on the surface of the Sphere Cone
- Temperature Rise at nose of body (predicted by ANSYS) simulation
  - Initial temperature rise is faster than that of 1D Slab (due to the usual spherical body effects)
  - After  $t > 0.2s$  the temperature rises more slowly due to conduction to cold side walls and aft-body
- Conical analysis breaks down (nose radius is 6.35mm while sensor is 10mm long)
- Heat Flux deduced by the 1D Finite Slab solver is not as bad as one might think
  - Deduced heat flux is at most 15% higher than the imposed heat flux (of the ANSYS simulation)
  - Spherical geometry effects appear to be balanced by lateral conduction (to the cooler side walls)

# Modified 1D Analysis to Emulate the Effects of cold after-body

- 1D Finite Slab analysis over-predicts the heating
- Conical Analysis corrects the spherical effects, but causes an under-estimate of the heating when non-uniform heating effects are present
- Performing a conical analysis as if the shell were 10% thicker and whose nose radius was 25% greater (more blunt) results in a deduced heating from the 1D analysis that agrees with the imposed heating to better than 1% over most of a 2s exposure.



Cylindrical Analysis



Conical Analysis



Thicker Shell

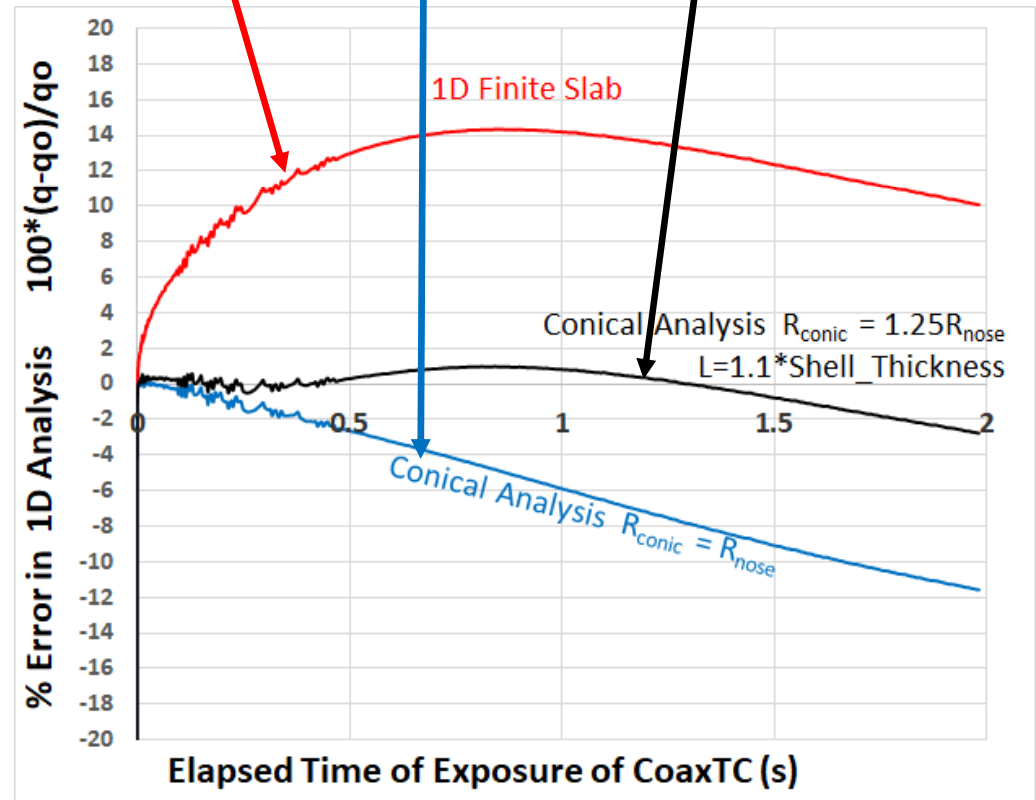

# 102mm Hemi Heat Flux Measurements with Various Sensors

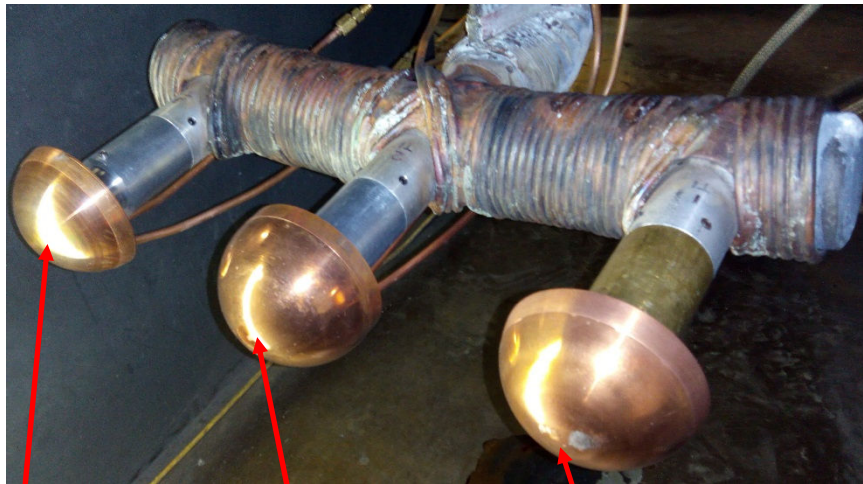

Null Point      Gardon Gage      Coaxial TC

4" Hemi with  
Pressure tap and  
temperature sensor

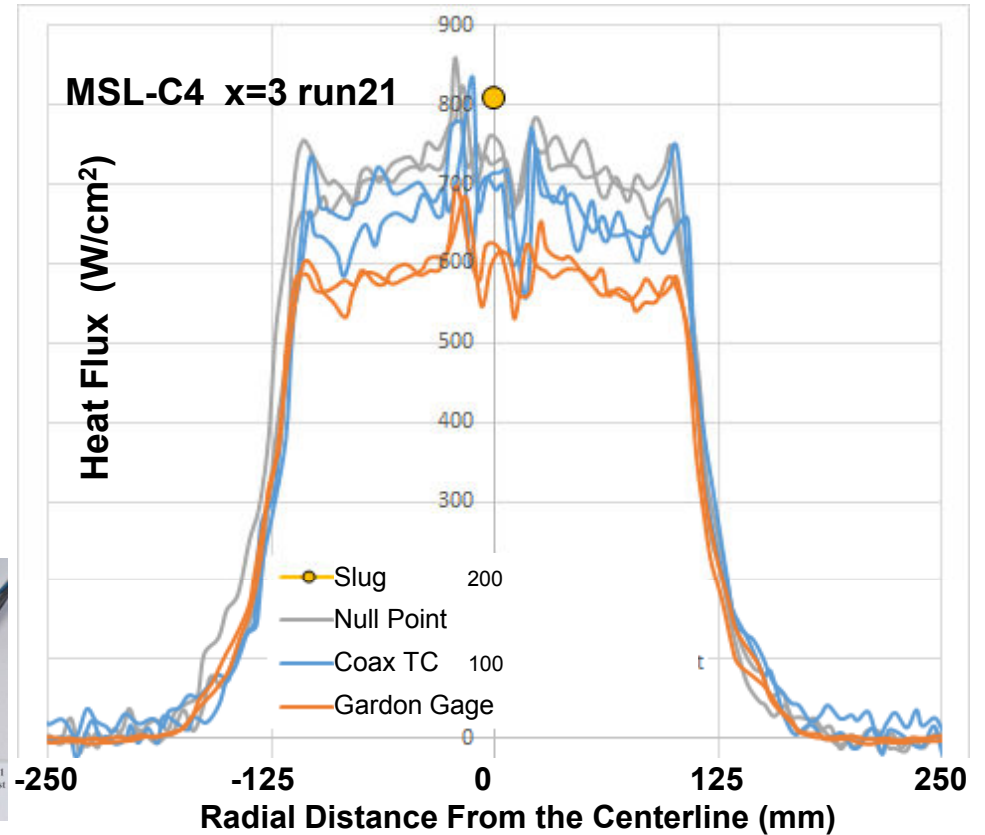

## Fast Response Sensors (Null Point, CoaxTC, Gardon Gage)

- Coax TC is in the middle of the range of possible measurements
- Null Point measuring +7% higher than the Coax TC
- Gardon Gage measuring -13% lower than the Coax TC
- Slug measuring +15% higher than the Coax TC
- Coax, NullPt & Gardon give similar shaped radial distribution of heat flux

# 102mm Hemi Heat Flux Measurements with Various Sensors

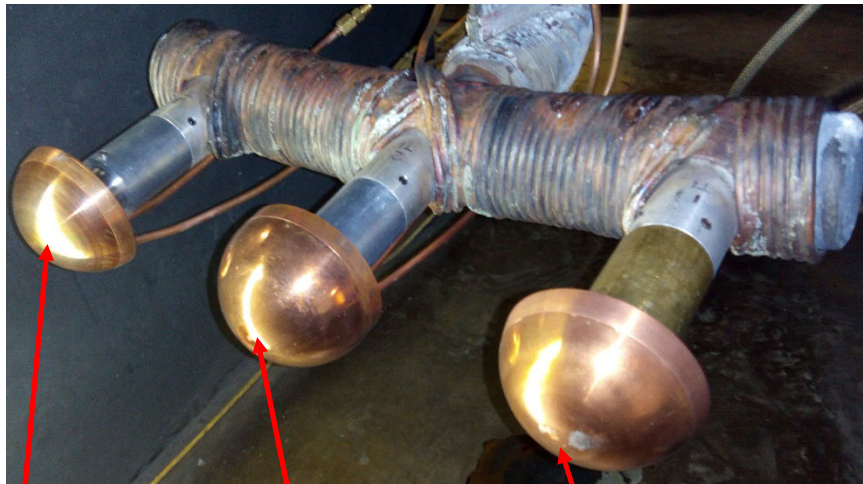

Null Point      Gardon Gage      Coaxial TC

4" Hemi with Pressure tap and temperature sensor

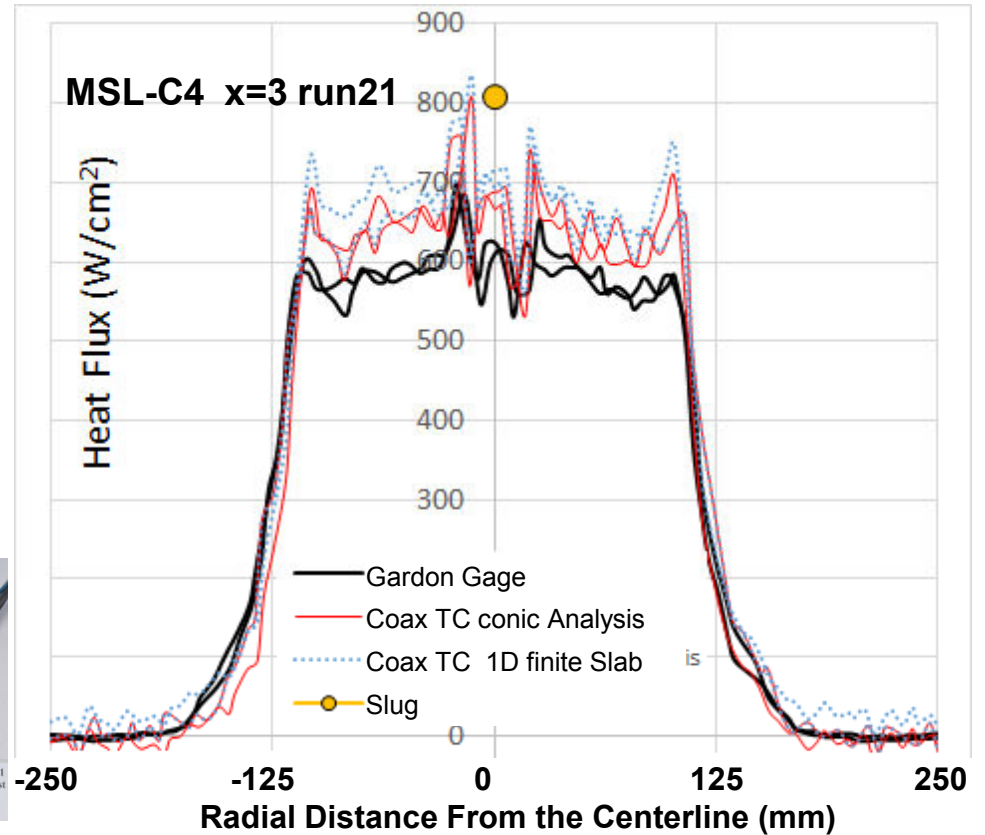

- Coax TC measurements using 1D finite Slab shown in Blue
- Coax TC measurements using Conical Analysis ( $R_c=1.25 R_{nose}$ ,  $L_c=1.1 L_{shell}$ ) in Red
- Gardon Gage measurements shown in Black
- Slightly lower heating deduced with modified analysis.
- Better agreement between forward and backward sweeps
- More nearly zero heat flux after probe exits the flow

# Summary

- Spherical Nose shaped calorimeters suffer 2D effects
- The 2D effects are greatest for calorimeters whose shell is thick relative to the radius of curvature of the body
- The 1D finite slab analysis gives Bias errors as much as
  - 6% over estimate of the heating for the 102mm IsoQ calorimeter body
  - 14% over-estimate of heating for the 102mm Hemispherical calorimeter body
  - 15% over-estimate of heating for the 12.7 mm Sphere Cone calorimeter body
- The spherical effect can be eliminated by recasting the 1D analysis in spherical coordinates
- The non-uniformity in heating can be dealt with by using an adhoc change to the conical analysis (i.e., adopt a 25% blunter nose radius and a 10% thicker shell)
- This modification to the conical analysis knocks down the error in deduced heating to ~1% for the HemiSpherical Calorimeter Body Shape

# Back Up

.

• .

# 12.7mm SphereCone Calorimeter – Sensor Glued into Body

an Attempt to Insulate the sensor from the body and make its response more 1D

*Sphere Cone body with  
CFD heating Imposed*  
ANSYS 2D Conduction Analysis

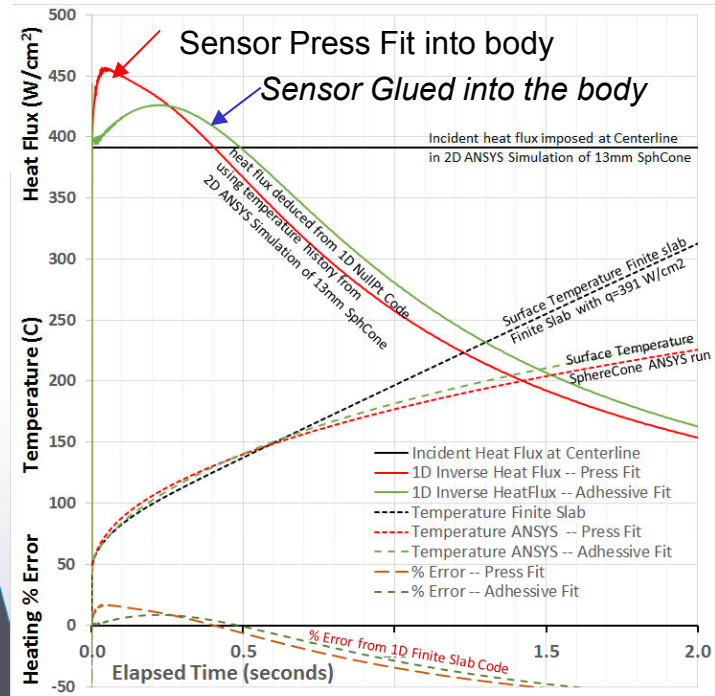
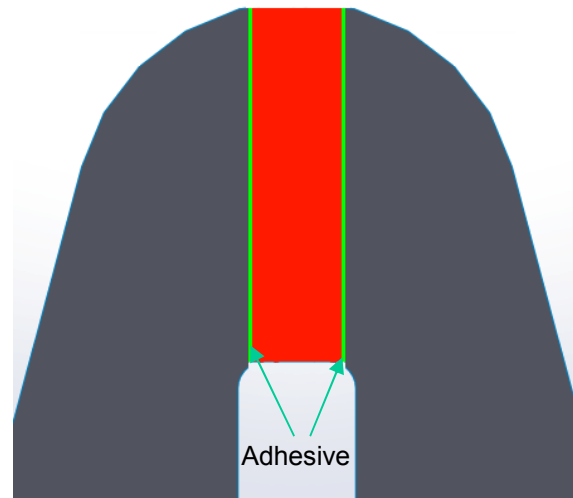

- 50  $\mu\text{m}$  thick ceramic insulating layer (Ceramabond)  
assume  $k=0.7 \text{ W/(m}\cdot\text{C)}$ ,  $\rho=1560 \text{ kg/m}^3$ ,  $C_p=880 \text{ J/(kg}\cdot\text{C)}$
- Resulting Temperature Rise at nose of body is slightly closer to that of a 1D Finite Slab thanks to the sensor being slightly more isolated from the body by virtue of adhesive
- Lateral conduction through the adhesive is never-the-less substantial
- After  $\frac{1}{2}$  second of exposure the lateral conduction (to the cold afterbody) again overwhelms axial conduction process
- AEDC has been gluing their Coax TC's into the body (since 1994) for the purpose of electrical insulating the sensor from the body – thermal insulation is a secondary benefit
- The results with insulation are qualitative as the exact thickness of the glue is not known



# Time Varying Heating on the IsoQ

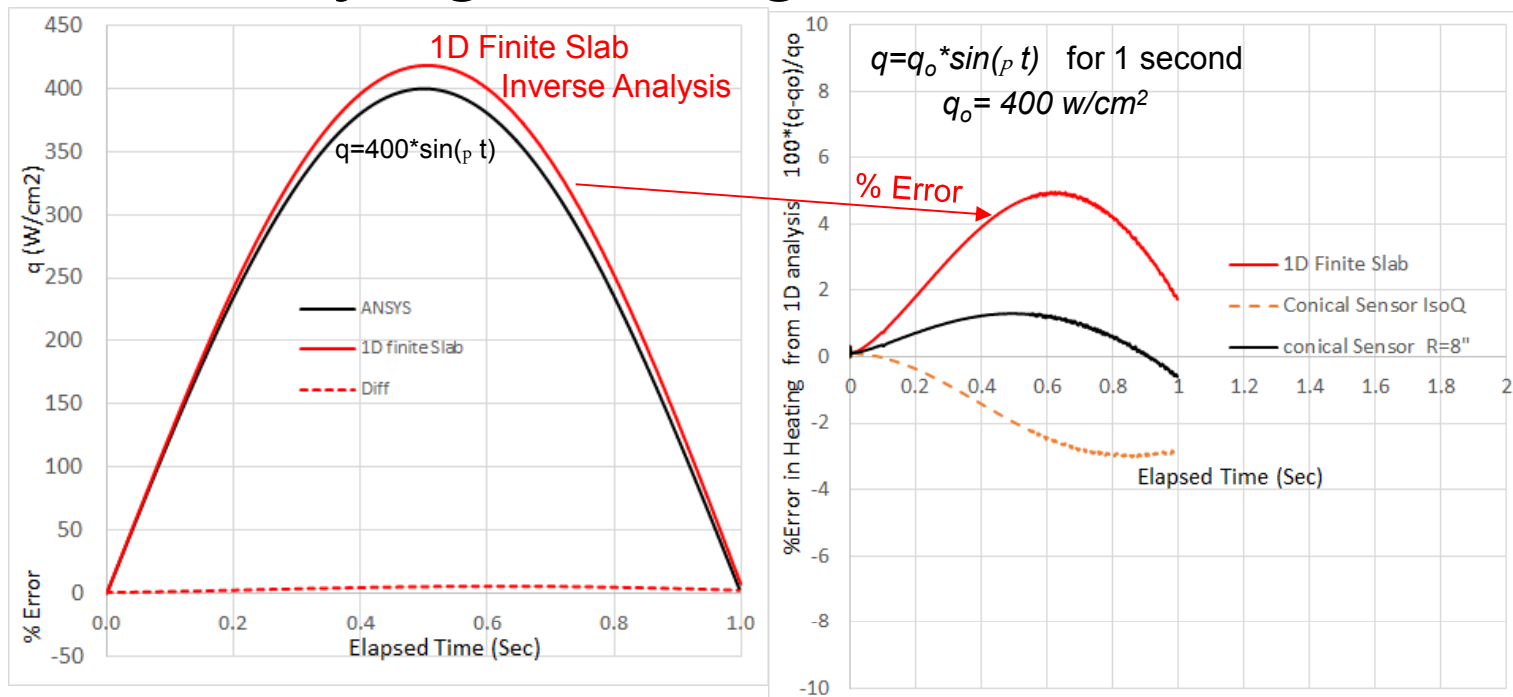

- Calorimeters swept through the arc jet undergo a sinusoidal variation in heating as the calorimeter goes in and out of the jet
- Here we ran an ANSYS simulation with centerline heating of  $q = 400 \sin(\pi t)$
- The lateral heating also drops off as  $\cos(\theta)$  as the radial angle ( $\theta$ ) increases with respect to centerline

# Time Varying Heating on the IsoQ

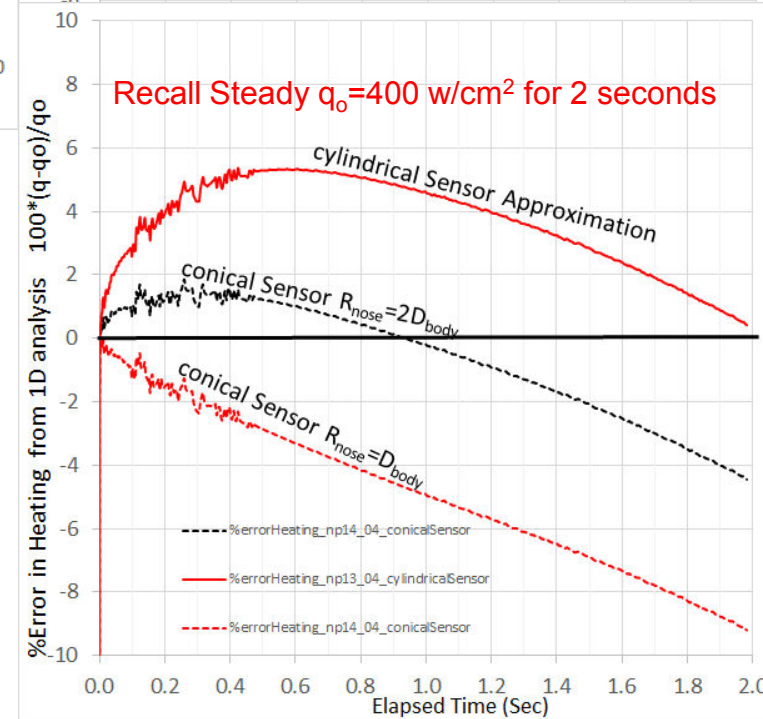
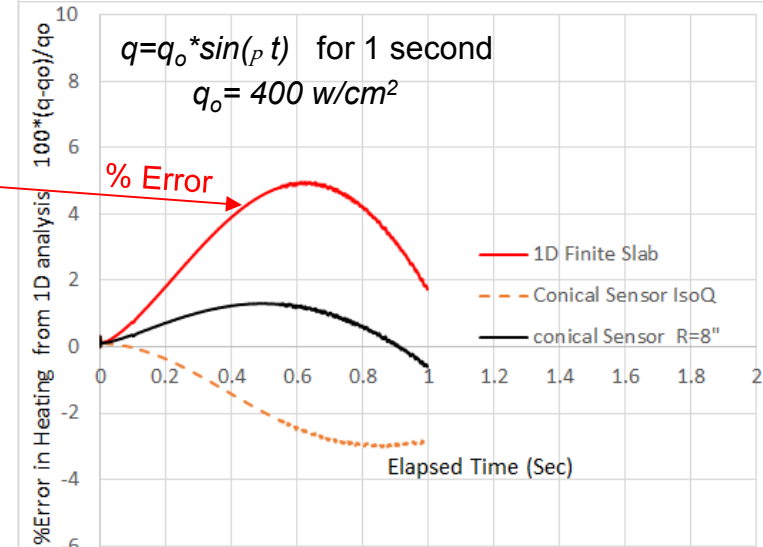
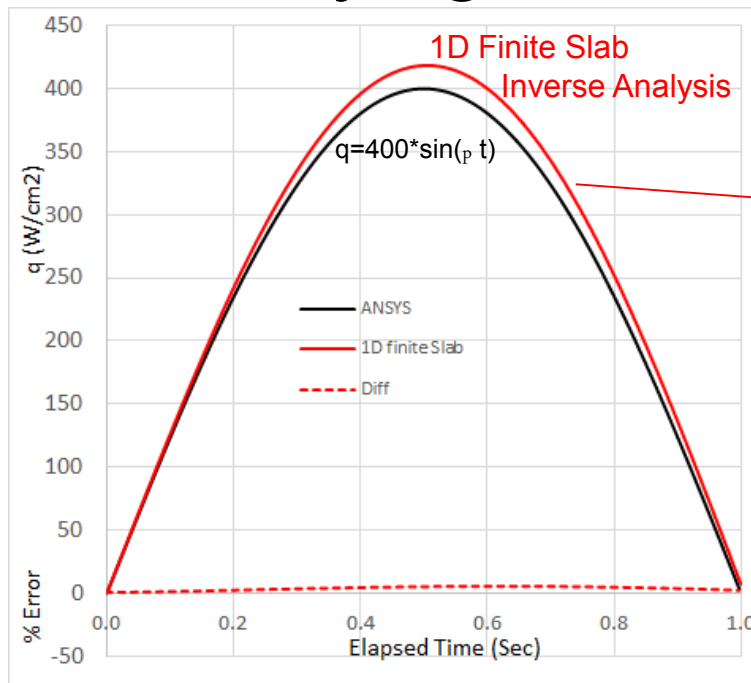

- Similar uncertainty between steady state simulation and time varying simulation
- Using conical sensing element with  $R_{nose}=2*R_{actual}$  reduces the error in both steady state and time varying simulations