

## Advanced Feedstock for Additive Manufacturing from Molten Regolith Electrolysis (MRE)

**PI:** Robert P. Mueller, [rob.mueller@nasa.gov](mailto:rob.mueller@nasa.gov) **Co-I:** Laurent Sibille, Ph.D., [laurent.sibille-1@nasa.gov](mailto:laurent.sibille-1@nasa.gov)

**Collaborators:** Jason Dunn (Made in Space Inc.); Prof. Sudipta Seal, University of Central Florida's (UCF) Materials Science and Engineering Dpt.; Kevin Grossman, PhD Candidate, UCF & Swamp Works Pathways Intern

**Primary TA:** TA 07.1.4 Human Exploration Destination Systems, Manufacturing & Infrastructure Emplacement.

**Start TRL:** 1 **End TRL:** 2

**Goal:** Advance Molten Regolith Electrolysis (MRE) as a technology for the production of raw materials feedstocks for additive manufacturing from lunar regolith (Sibille, 2009)<sup>1</sup>, such as metals, glasses, ceramics for In Space Fabrication and Repair (ISFR) along with by-product oxygen for In Situ Resource Utilization (ISRU) consumables supply. Demonstrate novel reactor thermal start techniques and use of ferrosilicon as metal product of MRE to make feedstock for wire-based additive manufacturing.

**Gap:** As NASA and private space enterprises aim to expand the reach of human crews farther from Earth, the use of in-situ resource utilization technologies and the in-situ capability to produce feedstock materials for on-board fabrication would transform space missions into truly sustainable space endeavors. In turn, it will change our role in the Solar System from periodic visitors to self-sustaining dwellers and ultimately permanent inhabitants.

The MRE technology was advanced in the 2000's under KSC leadership with MIT (Sibille, 2009)<sup>1</sup> as a variant of Molten Oxide Electrolysis (Sadoway, 1991)<sup>2</sup> for Off-Earth planetary applications and is also a zero-waste processing technique for feedstock for advanced manufacturing. It produces primary metal by direct electrolysis of the molten regolith electrolyte requiring only electrical energy without chemical reagents as polluting side products. The use of inert anodes enables the pollutant-free production of oxygen, an approach also pursued commercially by Boston Metal for the production of iron<sup>3</sup>. By comparison with another industrial electrolytic process, current primary aluminum production creates massive amounts of CO<sub>2</sub> through the use of consumable graphite electrodes and fluoride-based dissolving agents.

Space manufacturing represents a new economic sphere for the US and this project pioneers a new dimension in this field. This investigation examines the usefulness of ferrosilicon metal, a product of MRE in making feedstock for AM to advance the potential integration of MRE with in-space additive manufacturing (3D printing) technology. This work also investigates techniques to perform a cold-start of an MRE reactor without the use of external resistive heaters, thus addressing a critical operational

---

<sup>1</sup> Sibille, L., Sadoway, D.R., Sirk, A., Tripathy, P., Melendez, O., Standish, E., Dominguez, J.A., Stefanescu, D.M., Curreri, P.A. and Poizeau, S., 2009. "Recent advances in scale-up development of molten regolith electrolysis for oxygen production in support of a lunar base." In *Proc., 47th AIAA Aerospace Sciences Meeting, American Institute of Aeronautics and Astronautics (AIAA), Reston, VA (Vol. 2)*.

<sup>2</sup> Sadoway, D. R., Massachusetts Institute of Technology, Cambridge, MA, "Apparatus and method for the electrolytic production of metals," U.S. Patent No. 4,999,097, March 12, 1991.

<sup>3</sup> Boston Metal website: <https://bostonmetal.com/moe-technology/>

component of the technology. The newly acquired knowledge will serve to further the overall technology readiness level (TRL) of MRE and its usefulness for NASA programs.

## Approach & Innovation

**Approach:** The project team consisted of NASA KSC personnel and on-site contractors at the Swamp Works Granular Materials and Regolith Operations lab (GMRO), a PhD candidate at University of Central Florida (UCF) and Pathways intern at GMRO, and engineers at Made in Space, Inc. The team also received support from personnel of the KSC Materials Science Labs for metal characterization. A partnership was established with materials scientists at RDO Induction, Inc. via procurement of a test of a KSC Swamp Works starter device concept.

The objectives pursued were as follows: 1) Produce and characterize feedstock that meets the requirements for 3D printing using alloy compositions generated by the MRE process (Sibille, 2009)**Error! Bookmark not defined.** 2) Create a part with resulting feedstock with Made in Space novel printing technology and measure tensile strength of made part. 3) Demonstrate that a cold-wall MRE reactor can be started with a method of internal heating that integrates well with the subsequent operations of the reactor.

**Objectives 1 & 2:** The KSC-based team worked with UCF personnel and consultants at “Made in Space” to define the requirements of feedstock for a “Made in Space” additive fabricator and select suitable production techniques. The compositional range of such feedstock materials were defined to be within the values given by various regolith processed by MRE. The cathodic products are typically rich in iron and silicon with minor inclusions of other metals such as aluminum and titanium. The investigation began with researching published data on the various compositions and assessing their suitability to be used in producing materials of required shapes (wire, powder, pellets) and properties (melting point, ductility, strength, electrical resistivity) for selected additive manufacturing techniques. The team worked on selecting the methods of production and design a wire or powder production experiment of the feedstock material in sufficient quantities. The production of feedstock materials was planned to be performed in batches to be evaluated and iterated until they meet requirements for part fabrication. Made in Space worked on using the wire feedstock samples in their proprietary additive manufacturing technology to make test parts that could be tested for tensile strength.

**Objective 3:** The KSC-based team reviewed the design constraints of a MRE reactor established by previous modeling and experimental work on these systems and identified the thermal requirements of a starter device for the reactor. The operational concepts of MRE reactors were described and defined the operational envelope of the starter device and its integration in the system. The team brainstormed several technical options and ranked them based on compatibility with the reactor, feasibility of a concept demonstration within the resources available to the project, and its potential for success.

**Innovation:** The Molten Regolith Electrolysis (MRE) process has been demonstrated to produce raw feedstock materials and oxygen at high yield with lunar materials under KSC leadership in collaboration with MIT with NASA’s ISRU project funding in the 2000’s (Sibille, 2009)<sup>1</sup>, during which the performance of externally heated MRE reactors were characterized during production operations. Among current chemical processing techniques being considered for ISRU, MRE offers the only one-step process to produce oxygen and metals collected at opposite electrodes by direct electrochemical separation of molten metal oxides. Melting the regolith rather than involving chemical solvents to dissolve the ore as in the terrestrial production of aluminum simplifies the design, greatly reduces contamination of the produced oxygen and metals, lowers overall landed mass and frees the technology from dependence on consumable components that may not be readily available on other planetary surfaces. MRE is also the only existing technology to deliver molten metals in their raw form, flowing, moldable, and available for processing to become stock for additive manufacturing (3D printing) to enable fabrication and repair

**techniques.** This and its higher yields of oxygen and metal per unit mass of soil give MRE an edge over techniques requiring chemical reagents in spite of the electrical energy required.

The overall energy required for operation can be reduced by removing the need for external heaters to keep the regolith mass molten; instead the reactor is made large enough to rely on Joule-heating by the passing electroreducing current to keep the melt at operating temperatures near 1600 °C. This so-called “cold-wall” MRE reactor also solves the major challenge of containing oxide and metallic melts at high temperatures within the shielding layer of solid regolith between the molten reactor core and reactor walls. Presently, there is no published solution for starting such MRE reactors by forming an initial oxide melt surrounded by granular regolith material.

The team successfully developed and tested a viable concept for starting a cold-wall MRE reactor by internal Joule heating of consumable tubes of ferrosilicon or iron that can be produced in-situ by the same reactor operating on planetary surfaces for the production of primary metals for AM. The starter device is based on the use of inductive heating of the iron/ferrosilicon to the point of melting the regolith surrounding it while preserving the outer shell of granular regolith material characteristic of a cold-wall MRE reactor. The team also successfully synthesized ferrosilicon alloys over a wide range of compositions in silicon and demonstrated the manufacturing of wires from such alloys. These wires were used in AM tests of ingots for materials testing.

## Results & Knowledge Gained:

### A. Ferrosilicon (FeSi) alloys – synthesis, properties, shaping, and Additive Manufacture testing

#### 1. Materials and methods

Samples of ferrosilicon were synthesized over a wide range of compositions to characterize their fundamental electrical and physical properties, which are generally unknown for many ferrosilicon compositions, due to the limited terrestrial uses for ferrosilicon. The Si content of the synthesized samples ranged from 3 to 75 wt.%. These compositions were chosen based on the features of the phase diagram<sup>4</sup> (Fig. 1) and to include the entire range of FeSi alloys potentially produced from lunar regolith in a MRE reactor.

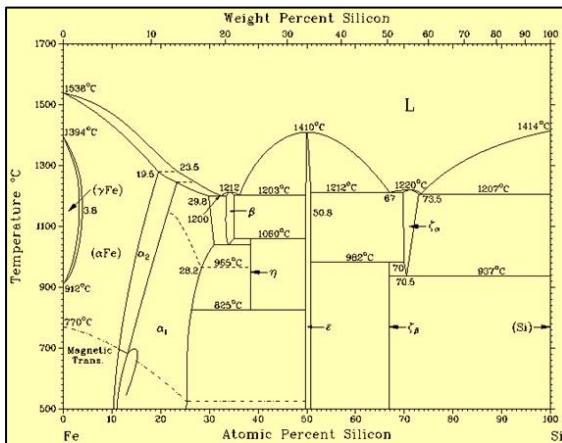

Figure 1. Phase diagram of ferrosilicon (FeSi)<sup>5</sup>



Figure 2. FeSi6 (6 wt.% Si) made in arc melter under Ar.

A set of 60 g samples were synthesized using a Materials Research Furnaces ABJ-900 Arc Melter which offers rapid melting of metals under a controlled atmosphere (Ar) environment. The arc melter

<sup>4</sup> Massalski, T.B., Okamoto, H., Subramanian, P.R. and Kacprzak, L., “Binary alloy phase diagrams.” vol. 3. *ASM International*, 1990, p.1485.

enables the synthesis of ingots (Fig. 2) without shape control thus is not suitable for the molding of samples into rods, flat bars, and sheets.

## 2. Characterization of ferrosilicon alloys

Characterization of the samples was performed jointly at UCF's Materials Characterization Facility (MCF) and at Kennedy Space Center's Materials Science Branch characterization laboratory to yield data on chemical and crystallographic composition, electrical resistivity, and hardness (Rockwell).

The hardness data collected in this project exhibits values below 30 for FeSi at low Si content below 10 wt.% indicating a ductility similar to that of common steels that allow wire pulling to below 1mm in diameter. These compositions also exhibit low electrical resistivity ( $< 6 \text{ E-}04 \text{ } \Omega\text{-m}$ ) to be usable as feedstock wires in the Made in Space arc-based 3D metal printing technology. The team thus focused their efforts to making FeSi feedstock within 0 – 10 wt.% Si in the final phase of the project.

## 3. Processing of net shape rods for wire manufacturing

The wire manufacturing technology made available by Made in Space to this project requires that the material to be drawn be in the form of rods of diameter no larger than 3.175 mm (0.125"). After trials, casting and machining samples into rods were discarded for practical reasons. In-furnace net shape rod molding was successfully implemented and yielded several homogeneous samples molded in high-density alumina tubes.

## 4. Additive Manufacturing tests using FeSi wire feedstocks

The hardness data and electrical conductivity provided by GMRO to Made in Space enabled our partner to calibrate the AM process with low Si steel wires and a pure iron wire. The metal-AM fabricator is capable of multi-layer free-form fabrication by arc-based metal joining using 3 degrees of freedom under a flow of 100% Ar. The most successful test was conducted with a cored wire made of a low carbon steel sheath surrounding a core of Si powder with a total silicon concentration of 28 wt.% (Figs. 3 & 4.)

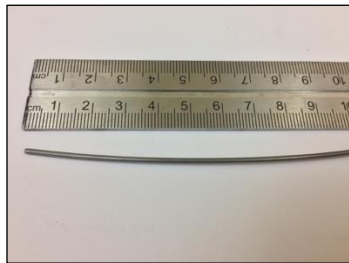

Figure 3. Steel sheathed wire with 28 wt.% Si used in AM tests.



Figure 4. Set of AM tests using the 28 wt.% Si FeSi wire. The beads are solid, and minor cracks are observed on surface.

## B. Starter Device for Molten Regolith Electrolysis Reactor

The electroreduction of metal oxides can only take place once the electrolyte pool between the electrodes is fully molten, thus allowing the passage of electrical current via ionic conduction created by the migration of anions and cations. In the case of regolith mixtures, these melts typically form in the range of 1000 – 1250 °C and display high viscosity around their melting points. Effective conduction thus requires superheating the melt to become an electrolyte pool. The MRE reactor also operates at temperatures ca. 1600 °C due to the requirement of achieving the melting point of iron (1538 °C), which constitutes one of the metals reduced early in the process and that accumulates at the cathode at the bottom of the reactor. The iron then alloys with metals such as silicon that is reduced next in the process.

These thermal requirements are imposed on the potential starter device in addition to the physical and operational constraints of the reactor system. The following design features and performance characteristics of the starter device were described:

- The device must achieve the melting of a bed of regolith situated between the anode and the cathode ca. 1200 °C while maintaining a surrounding wall of unmolten, granular regolith.
- The device must be integrated in the pre-melting operations of the reactor and the electroreduction sequences that follow melting.
- The device must either be sacrificial or be a permanent fixture of the reactor or a combination of sacrificial parts and permanent structure. If sacrificial, the materials of its composition must be fully compatible with the metals targeted for production and not add any contamination to the products and the regolith melt.
- The device must be serviceable during in-space operations on planetary surfaces where the reactor will be placed. This requirement imposes further requirements on the permanent fixtures of the device that must have a long-life expectancy inside the reactor and on the sacrificial parts that must be resupplied inside the reactor at each restart.

Many potential concepts were either rejected for failing one of the requirements or ranked according to the feasibility of testing the concept within the scope and resources of this CIF project. Accordingly, the concept of an Induction Heating Starter Device was tested in partnership with RDO Induction, Inc. The device consists of coupling the magnetic field generated by an induction coil with a metal susceptor such as iron or ferrosilicon inserted in the bed of granular regolith between the anode and cathode. The use of the sacrificial metal items enables their ultimate fusion into the metal pool of similar composition. The electrodes are not involved in this technique.

The induction heating proof-of-concept tests recorded an output power of the induction field generator at ca. 7.5 kW for two minutes duration to achieve melting of iron pipe segments within a “cold wall” of regolith lining the inside of the crucible (Fig. 5.) This short time to melt confirms that an inductive starter device has the potential of achieving the formation of the electrolyte pool in an overheated molten state quickly and repeatedly and thus integrate well with the subsequent MRE electrolysis sequence. Additional work on temperature monitoring, arrangements of susceptor in regolith, placement of coils, and effectiveness of pure iron and low silicon ferrosilicon as susceptors is warranted to design a prototype starter device. We conclude that this concept was proven successfully as a potential technique.

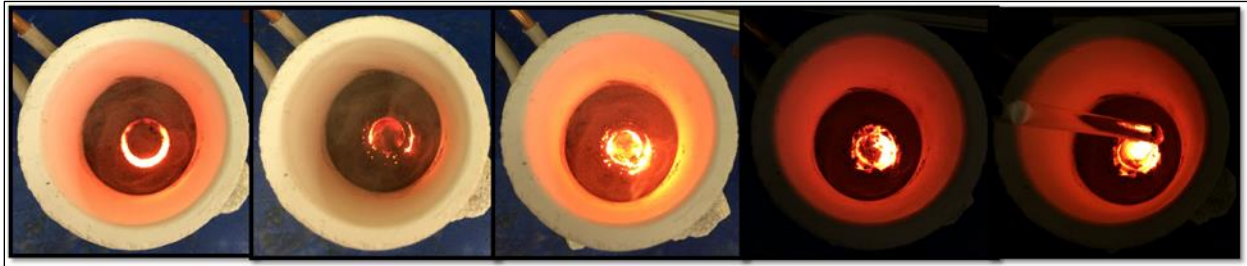

Figure 5. Time sequence of melting iron pipe segment by induction field coupling within 2 minutes. A wall of granular regolith was left intact lining the crucible.

**Technology Maturation Opportunities:** R. Mueller and L. Sibille are pursuing further funding to build on the initial success of this low TRL investigation. Interest has been shown by the NASA ISRU project management in continuing this work as part of the NASA ISRU technology development portfolio with lunar applications.

**Partnerships:** We also wish to acknowledge our collaborators and partners Derek Thomas and Mike Snyder at Made in Space, Inc. and Iain Bates and Taha Mirhoseini at RDO Induction, Inc. for their dedication, expertise and enthusiasm for this project.

**This PDF contains four Report Summaries**

17-2 Mars CO<sub>2</sub> Capture using Sorbent Fiber Materials for In-Situ Resource Utilization

17-3 Novel Materials for Biofilm Inhibition

17-4 Planetary Mobile Mining and Scalable In-Situ Water Extraction System  
for the Mars Surface

17-5 WeIDEAS

The fifth Report Summary 17-1 is attached separately.

## 17-2 FY17 Mars CO<sub>2</sub> Capture using Sorbent Fiber Materials for In-Situ Resource Utilization

**PI:** James Mantovani, [James.G.Mantovani@nasa.gov](mailto:James.G.Mantovani@nasa.gov)

**Primary TA:** TA07 Human Exploration Destination Systems (ISRU Atmospheric Processing),

**Secondary TA:** TA06 Life Support (ECLSS for air revitalization by CO<sub>2</sub> removal)

**Starting TRL:** 2, **Ending TRL:** 3

**Goal:** Use permanently microporous structures known as polymers of intrinsic microporosity (PIM-1), which have been loaded with CO<sub>2</sub>-philic molecules of poly(ethyleneimine (PEI) in the range of 0 – 25 wt%, to determine their effectiveness for adsorbing carbon dioxide gas (CO<sub>2</sub>) from a simulated Mars atmosphere (7 torr), and show that the captured CO<sub>2</sub> can be released via desorption by heating the PEI/PIM-1 composite material controllable way.

**Gap:** The AES ISRU project requires a technology to capture and store CO<sub>2</sub> in the atmosphere on Mars to feed a methanation subsystem that catalytically combines CO<sub>2</sub> with hydrogen in a Sabatier reactor to form methane and water. The state-of-the-art for capturing atmospheric carbon dioxide on Mars for in-situ resource utilization (ISRU) atmospheric processing involves either (1) freezing atmospheric CO<sub>2</sub> molecules using cryocoolers and then sublimating the CO<sub>2</sub> later to pressurize a storage tank, (2) compressing the CO<sub>2</sub> directly using an electromechanical pump, or (3) adsorption by CO<sub>2</sub> sorbent materials. The adsorption method is potentially more energy efficient than the other two methods since sorbent materials require thermal energy only when desorbing CO<sub>2</sub>, but not during the initial adsorption process. However, the current choice of the sorbent system is based on inorganic zeolite pellet-bed systems. While it's very effective as a CO<sub>2</sub> sorbent, zeolite does have a few drawbacks including the weight and size of the pellets, which affect the rate and duration of thermal heating needed to regenerate the system, and their similar ability to adsorb water molecules simultaneously with CO<sub>2</sub> molecules, which then occupy adsorption sites that are no longer available for CO<sub>2</sub> molecules.

### Approach and Innovation

**Approach:** KSC teamed with Georgia Tech, which had developed a wet chemical process to impregnate PIM-1 with poly(ethyleneimine) (PEI) in the range of 0–25 wt% to produce fibers able to capture CO<sub>2</sub> in air. Georgia Tech developed the material for mitigating industrial CO<sub>2</sub> pollution in air emitted from large point sources such as coal- and gas-fired plants. Current research efforts at Georgia Tech seek to develop novel geometries, such as hollow sorbent fibers, to yield highly space-efficient adsorbents with improved heat mass management, lower pressure drops, and greater rapid mass transport as compared to traditional inorganic pellet-based systems, such as zeolite. PIM-1 fibers have a high surface area (720 m<sup>2</sup>/g) and the addition of PEI is known to aid in the capture of CO<sub>2</sub>. The samples that were tested at KSC were fabricated at Georgia Tech in the form of fibers and as 3D printed mats. Testing was performed at KSC using unattached PIM-1 fibers as a baseline for subsequent testing of PIM-1 mat samples.

**Innovation:** KSC investigated an innovative space application of the PEI/PIM-1 composites in which the thin, lightweight composites could be used to demonstrate a viable method to capture

CO<sub>2</sub> in the Mars atmosphere for later ISRU methane production. Other innovative applications include using CO<sub>2</sub> sorbent PEI/PIM-1 composites to support air revitalization on the International Space Station for Environmental Control and Life Support System (ECLSS), and for air control of CO<sub>2</sub> levels in Plant Chambers.

**Results and Knowledge Gained:** Under vacuum conditions at 35°C in a simulated Mars atmosphere of 7 torr CO<sub>2</sub>, the amount of CO<sub>2</sub> adsorbed by amine-free PIM-1 fibers is 0.02 mmol/g (milli-moles of CO<sub>2</sub> per gram of PIM-1 material), and 0.11 mmol/g at 40 torr CO<sub>2</sub> pressure. These values are expected to increase at lower temperatures. By contrast, at 1 atm in a room temperature mixed flow of 95% N<sub>2</sub> + 5% CO<sub>2</sub>, which corresponds to a CO<sub>2</sub> partial pressure of 40 torr, the amount of CO<sub>2</sub> adsorbed by amine-free PIM-1 material was measured to be about 0.08 mmol/g. This latter measurement simulates a test that might be performed after sampling the air on the International Space Station (ISS), although the partial pressure of CO<sub>2</sub> on the ISS is typically less than 5 torr. Since the molar mass of CO<sub>2</sub> is 44 g/mol, there is 1 g of CO<sub>2</sub> in (1/44) mol = 0.0227 mol of CO<sub>2</sub>. Thus, the instantaneous direct capture of 1 g of CO<sub>2</sub> from the Mars atmosphere using PIM-1 will require a total PIM-1 mass of (0.0227 mol) / (0.02 mol/kg) = 1.1 kg. Note: by compressing the Mars atmosphere in a closed vessel to 70 torr, the required PIM-1 mass needed to capture 1 g of CO<sub>2</sub> will be reduced to 0.11 kg (or 66 kg to capture 600 g = 0.6 kg of CO<sub>2</sub> per ISRU requirements).



Figure 1. (Left) Showing PIM-1 mat coupon designed and printed by Georgia Tech, and (Right) raw PIM-1 fibers fabricated by chemically dissolving raw PIM-1 material and drawing it out as a continuous fiber.

Figure 2. Showing heated CO<sub>2</sub> gas flow test cell setup where the CO<sub>2</sub> gas flowed across

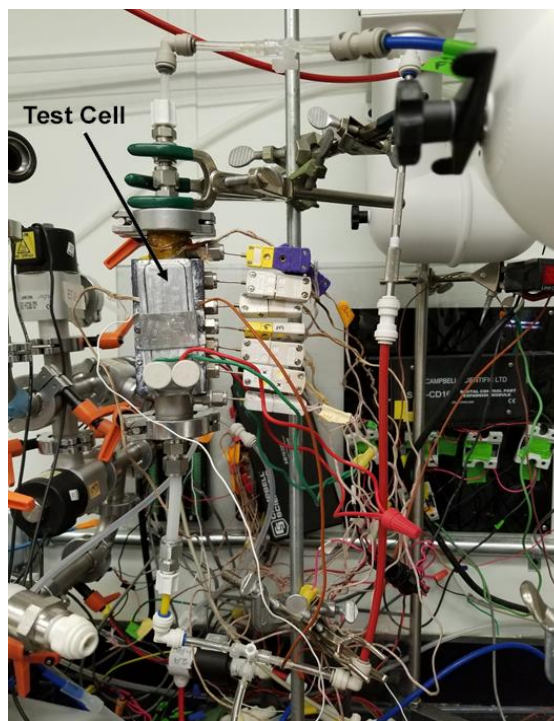

the PIM-1 coupons and the CO<sub>2</sub> uptake was measured.



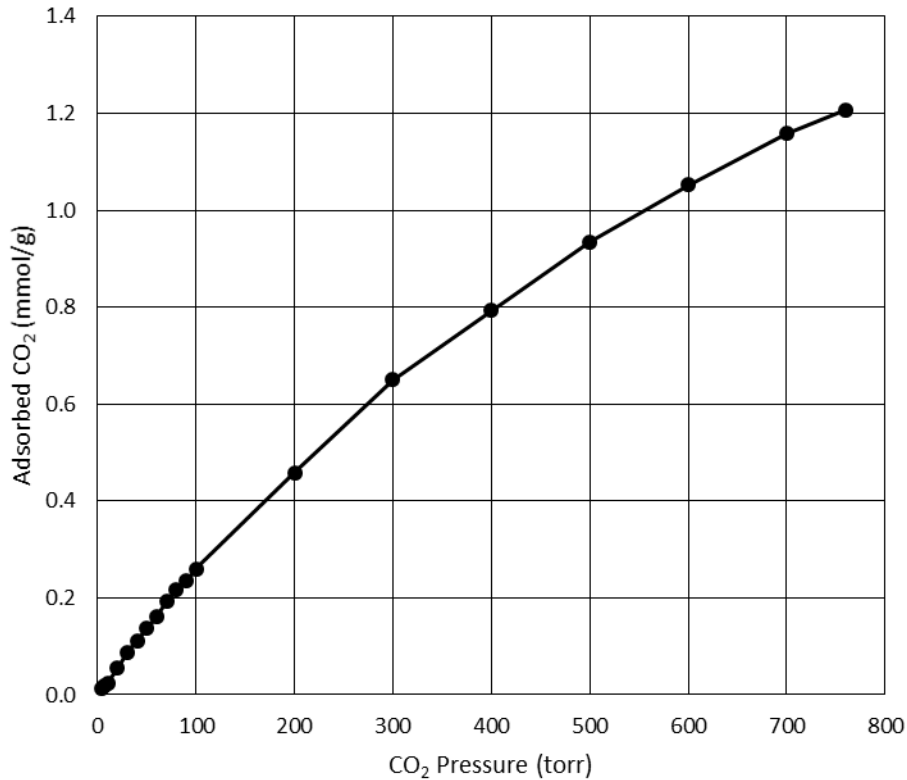

Figure 3. PIM-1 isotherm plot of adsorbed CO<sub>2</sub> (in mmol/g) as a function of CO<sub>2</sub> pressure (in torr) for PIM-1 fibers tested at a fixed temperature of 35°C (308 K). Note that 750 torr = 1 bar. Based on Georgia Tech data in research article: ACS Macro Lett. 4, 1415–1419 (2015).

**Technology Maturation Opportunities:**

- AES ISRU project WBS 4.1.3: Carbon Dioxide Separation, Collection, and Pressurization
- CO<sub>2</sub> Removal for Environmental Control and Life Support System (ECLSS) on the International Space Station
- Air Control of CO<sub>2</sub> for Plant Growth Chambers on the International Space Station

**Partnerships:** Dr. Ryan Lively, School of Chemical & Biomolecular Engineering, Georgia Institute of Technology, Atlanta, Georgia

**ACTIVITY DETAILS**

## **17-3 Title: Novel Materials for Biofilm Inhibition**

**PI: Dr. Luke Roberson**

**Activity Type / Phase** Center Innovation Fund (CIF) FY18

**Primary TA:** 6.2

**Start TRL / End TRL:** 1 / 4

### **Goal / Gap**

#### ***Goals:***

This project examined two novel types of materials coatings which discourage or eliminate biofilm formation. Omniphobic surfaces display contact angles greater than 150° with essentially all high and low surface tension liquids, including water, oils, alcohols, acids, bases, and blood; while phosphorylcholine (PC)-treated surfaces are highly hydrophilic, attracting water to form a water barrier on the material surface, resisting protein and cell adhesion. Both demonstrated great promise for inhibition of biofilm formation.

#### ***Capability Need/Knowledge Gap:***

Microbial contamination onboard the International Space Station (ISS) continues to pose significant mission risks, both in terms of crew health and functionality of mechanical systems. The ISS and Launch Services programs at KSC have expressed programmatic interest for mission infusion, to the extent that the LSP office was willing to provide flight experiment equipment to test the coatings in the future.

### **Approach / Innovation**

#### ***Challenges/Innovation:***

To accomplish our goals for understanding how surface chemistry can be used to alter the fluid physics and improve microbial control in microgravity environments, the team examined how the surface tension and capillary force flow exerted from the physical properties of the coatings would increase resistance to microbial attachment and subsequent biofilm formation. The challenge was maintaining the long-term control of microbial contamination and biofilm development in systems, particularly in the water storage/distribution systems and in food production/storage materials.

#### ***Approach/Next steps:***

In order to identify novel non-toxic, biofilm-resistant materials capable of inhibiting multispecies biofilm formation, we have conducted material characterization and microbiological testing on the surface of materials treated with omniphobic and phosphorylcholine coatings. To understand the fundamental aspects of surface chemistry on microbial control, we first examined biofilm formation phenomena over time for microorganisms isolated on the ISS - individually and in a mixed community. Among the coating systems evaluated, an omniphobic coating with hierarchical surface features (nano-roughness superimposed on micro-roughness) resulted in

significantly fewer bacteria attaching to the surface than the uncoated control, both for single and mixed culture exposure. Parabolic flight experiments also verified their physical properties under microgravity. These results at KSC showed that these omniphobic coatings are promising candidates as biofilm resistant materials.

Our next step, in collaboration with the NASA KSC Launch Services Program, is to coat the omniphobic material onto the interior surface of the NASA SLOSH system and observe how the coating performs on a large water storage tank aboard ISS. If approved and funded, the project will begin in FY19-20. The team is also examining applying this surface coating to NASA water system applications at KSC to raise the TRL to 5-6 for direct applications for NASA technology infusion.

### **Results / Knowledge Gained:**

Initial testing was performed on coupons (both metal and polymer-based) with multiple omniphobic and PC coatings. Partners at the University of Michigan fabricated and provided different omniphobic surfaces possessing hierarchical textures on various polymer and metal coupons. Similarly, the PVA Tepla America team treated various materials with several PC-based compounds. Physical characterization using X-ray Photon Spectroscopy (XPS), Scanning Electron Microscopy (SEM), as well as surface roughness and contact angle/surface free energy analysis was completed. A correlation between physical characteristics and the effect on biofilm formation was examined and reported in a scientific publication ([https://ttu-ir.tdl.org/ttu-ir/bitstream/handle/2346/74084/ICES\\_2018\\_83.pdf?sequence=1&isAllowed=y](https://ttu-ir.tdl.org/ttu-ir/bitstream/handle/2346/74084/ICES_2018_83.pdf?sequence=1&isAllowed=y)).

### **Partnerships:**

The project was performed in collaboration with Professor Anish Tuteja, Dr. Geeta Mehta, and Mathew Boban the University of Michigan, Ann Arbor. Michael Barden of PVA Tepla America in California provided phosphorylcholine coating samples. Microgravity flight testing was funded by the NASA MUREP program through a joint proposal with Gadsden State Community College (GSCC).

The project team would like to thank Dianne Mercado, NIFS/KSC for her assistance in biological tests; and Dr. Ye Zhang at NASA KSC and Dr. Srujana Neelam, NASA Postdoctoral Fellow at KSC, for their assistance in sample analysis using fluorescent microscope. The authors would also like to thank Dr. Luz Calle at NASA KSC for her input and helpful discussion. This project was funded through NASA KSC Center Innovation Fund.

### **Audience:**

STMD Leadership, STMD Principle Technologists, and Center Innovation Fund Management.

## 17-4 Planetary Mobile Mining and Scalable In-Situ Water Extraction System for the Mars Surface

**PI:** Robert P. Mueller, [rob.mueller@nasa.gov](mailto:rob.mueller@nasa.gov) **Co-I:** Laurent Sibille, Ph.D., [laurent.sibille-1@nasa.gov](mailto:laurent.sibille-1@nasa.gov)

**Team:** James G. Mantovani, Ph.D., [james.g.mantovani@nasa.gov](mailto:james.g.mantovani@nasa.gov); Nathan J. Gelino, [nathan.j.gelino@nasa.gov](mailto:nathan.j.gelino@nasa.gov); Ivan I. Townsend, [ivan.i.townsend@nasa.gov](mailto:ivan.i.townsend@nasa.gov); Jason M. Schuler, [jason.m.schuler@nasa.gov](mailto:jason.m.schuler@nasa.gov); Jesus A. Dominguez, [jesus.a.dominguez@nasa.gov](mailto:jesus.a.dominguez@nasa.gov); Oscar A. Monje, [oscar.a.monje@nasa.gov](mailto:oscar.a.monje@nasa.gov), Griffin Lunn, [griffin.m.lunn@nasa.gov](mailto:griffin.m.lunn@nasa.gov); Lawrence L. Koss.

**Collaborators:** Kris Zacny, Ph.D. Honeybee Robotics, Inc.

**Primary TA:** TA 07.1.2 Human Exploration Destination Systems, Resource Acquisition

**Start TRL:** 2 **End TRL:** 3

**Goal:** Advance technology for low-energy water extraction from Mars regolith simulant with minimal losses by pursuing two objectives: 1) demonstrate processing cycle for extraction of water from potential Mars regolith mineral sources without using the energy-intensive sublimation step to achieve large-scale extraction and 2) demonstrate an energy-efficient water mining concept by co-locating both regolith/ice excavation and water extraction within a rotating bucket drum excavator.

**Gap:** The NASA Science Mission Directorate (SMD) has completed a comprehensive study of the types of water resources that may be available on Mars. These resources are seen in FY16 Evolvable Mars Campaign (EMC) reports as an enabling factor of human presence on Mars. The feasibility of producing water by accessing and processing water-bearing soils and regolith at a large-enough scale on the Mars surface is tied to the reduction of overall energy requirements and production times via ISRU technologies selected for process efficiency and high-reliability designs. Current studies show high-energy requirements from processing and transport being major factors leading to a complex and vulnerable architecture. This project has studied possible solutions which, if successful could become part of NASA's technology investment planning in the next 5 years. Interest in these solutions is high within both SMD and the Human Explorations Operations Mission Directorate (HEOMD).

**KSC Strategic Technology Investment Plan:** The NASA technology theme: Human Health, and Human Exploration Destination Systems shows a requirement for resource acquisition on Mars for propellants for the Mars Ascent Vehicle (MAV) which brings the crew home. This project directly addresses this need.

Space Exploration Technologies Corp. (Space X) has stated a similar assessment of the need to access and process water on Mars in their pursuit to landing and establishing humans on Mars<sup>1</sup>.

The Department of Defense (DoD) could use this technology to extract water from hydrated minerals (e.g. Gypsum) on Earth in remote areas for human life support and fuel cells.

---

<sup>1</sup> E. Musk, "Making Life Multiplanetary", International Astronautical Congress 2016, accessed at [http://www.spacex.com/sites/spacex/files/making\\_life\\_multiplanetary\\_2016.pdf](http://www.spacex.com/sites/spacex/files/making_life_multiplanetary_2016.pdf) (06/29/18)

## Approach & Innovation:

**Approach:** Current approaches to extract water from mineral resources in space have been largely focused on two similar thermodynamic routes<sup>2,3</sup>. In the case of hydrated minerals, it proceeds as follows: collect the minerals, heat to liberate bound water molecules (calcination) and volatiles, transport water vapor and gas, condense water and remove impurities from liquid water. In the case of icy regolith and ice, it involves heating the material to the sublimation temperature of water followed by condensation of the water vapor. This route is energetically costly because of the thermal energy required to heat the icy regolith or ice frozen at very low temperatures to the sublimation point of water and then to overcome the large latent heat of sublimation. This processing route also requires to expand a large amount of energy to sublimate ice and follow that step with removing that heat from the vapor to obtain liquid water; this two-step approach leads to a system that must provide and extract heat sequentially, both steps requiring electrical power on Mars. Consequently, lower than expected extraction efficiencies occur experimentally due to thermal losses, including heat lost in the minerals themselves, condensation of the vapor phase in hardware during transport inside the processing plant, or through leaks. The complexity of sublimation and condensation also imposes limits on the up-scaling of the process necessary for the production of larger quantities of water required to supply multiple Mars Ascent Vehicles with fuel and a growing Mars outpost with multiple needs for water. Our approach is to investigate the feasibility of obtaining liquid water from Martian icy regolith by processing it at a pressure a few torr above ambient Mars pressure to melt it instead of sublimating it, thus gaining greatly in efficiency through a simpler route design that is more readily scalable. A similar thermodynamic route has been proposed for water extraction from subsurface Mars glaciers and is under investigation as part of the AES ISRU Project<sup>4</sup>.

In addition, one of the largest energy costs for water mining from regolith occurs when the regolith is repeatedly carried from the mining site to the in-situ resource utilization (ISRU) regolith processing plant. By processing the regolith in-situ, at the mining site, the regolith can be dumped and only the water "ore" needs to be transported back to the end user at the Mars station. This will result in significant energy savings and it will also reduce operational complexity while acquiring water on Mars for propellant manufacturing and other ISRU purposes. Regolith collected from the Mars surface can also be processed to water for breathing air, potable water, water for plant growth, and propellants such as methane, oxygen, and hydrogen. A bucket drum excavator design provides an enclosed volume that can be sealed at the scoop inlets to create a pressure vessel, in which the excavated regolith can be tumbled for efficient heat transfer. By heating the regolith inside the excavator, the water contained in hydrated minerals or present as ice can be extracted, captured and condensed for use in ISRU applications.

**Innovation:** Planetary mobile mining, with in-situ, on-board water extraction, is a distinctly different concept of operation for the mining of volatiles resources embedded in off-Earth regolith. Recent studies on the extraction of mineral resources on the moon and Mars have assumed that the regolith would be excavated and then hauled to a processing plant located near a power source and the lander at a base camp to extract, condition and store water and other volatiles. However, recent Mars landing site studies have indicated that the resources may not be close to the outpost (in the range of hundreds of meters distance) as previously assumed by past NASA studies. The new data indicates that the resource mining zones could be thousands of meters from the base camp, which motivated this team to analyze alternative solutions that involve mobile planetary mining with deployable power plants staged at the mining site and mobile mining robots that have on board regolith processing systems. In this concept of operations, the

---

<sup>2</sup> Zacny, Kris, et al. "Mobile In-Situ Water Extractor (MISWE) for Mars, Moon, and Asteroids In Situ Resource Utilization." AIAA SPACE 2012 Conference & Exposition. 2012.

<sup>3</sup> Linne, Diane, et al. "Extraction of Volatiles from Regolith or Soil on Mars, the Moon, and Asteroids." Planetary and Terrestrial Mining Science Symposium & Space Resources Roundtable (2017).

<sup>4</sup> Hoffman, Stephen J., et al. "A Water Rich Mars Surface Mission Scenario," 2017 IEEE Aerospace Conference, Big Sky MT, March 5-12, 2017.

extracted water would be the only commodity to be hauled to the point of use at base camp. Since the volatiles ore grades in hydrated minerals on Mars are expected to be between 1% to a maximum of 8% of water (in the case of gypsum), then hauling between 99% and 92% of regolith tailings over thousands of meters to a base camp processing plant becomes energetically and operationally questionable. In this study, we have investigated the feasibility of energy efficient water extraction from hydrated minerals and icy regolith for Mars, through trades of concepts of operations involving the primary excavator, extractive methods and hauling operations. We found that robotic planetary mobile mining with a scalable in-situ, on-board water extraction system may be feasible and desirable when the mining site is at distances of thousands of meters away from the point of consumption, either a base camp or an ascent vehicle.

We have conducted a preliminary experimental investigation of an alternate thermodynamic route to obtain water in liquid state from collected icy regolith and ice under surface condition on Mars. The innovation involves a minimal increase of the processing pressure from ambient pressure followed by a modest increase in temperature resulting in the melting of the ice instead of its sublimation. This approach offers the following advantages: The formation of water in liquid state occurs in the same container in which the ice-regolith mixture is introduced, thus eliminating the need for vapor transfer from one location to another, and the related thermal requirements on the system to perform the transfer with minimal losses. It also eliminates the need to remove heat from the water to condense it as a separate step prior to storage. The novel process scales readily in principle by adapting terrestrial drying technologies of rotary vacuum drum filtration, for which we have produced a preliminary design. It reduces the energy consumption for ice processing by minimizing phase changes in water, high thermal loads on heaters and heat losses in containment materials as well as using the pressure differential always available by the atmosphere of Mars.

## Results & Knowledge Gained:

### A. EXTRACTION OF MARS GROUND ICE IN LIQUID PHASE: EXPERIMENTAL INVESTIGATION

An example of processing path to obtain liquid water under low pressure from initial Mars surface conditions for storage if depicted in figure 1.

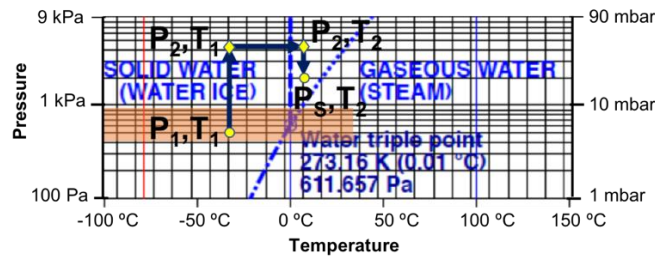

Figure 1. Processing path followed for Mars water extraction in liquid form (the shaded orange zone represents a range of ambient conditions on the surface of Mars. The ice/regolith mass in the extraction vessel is driven to a liquid mixture at  $P_2, T_2$  after which water is removed by vacuum drying to  $P_s, T_2$ ).

The route requires an isothermal increase of the pressure of the gas surrounding the ice to a point above the triple point ( $P_2, T_1$ ) followed by an isobaric increase of the temperature of the ice to obtain liquefaction. Once the liquid water is formed at ( $P_2, T_2$ ), it can be withdrawn isothermally for storage by a pressure differential created between the vessel and the ambient Mars atmosphere ( $P_s, T_2$ ), with  $P_s < P_2$ .

The fact that the concept being investigated is based on establishing stable pressure set-points under which water ice can be transformed into liquid state led to the selection of a small volume vacuum chamber made available by KSC Materials Science Branch.

The experiment was designed to be simple in its first iteration and verified the following hypotheses:

- 1) Water ice mixed with a glass substrate (chosen for its inert nature in contact with water and for its silica nature approximating silicate minerals in thermal behavior) can be stabilized as a solid under Mars pressure conditions at temperatures below the triple point.
- 2) Water ice can effectively absorb heat by conduction under pressure conditions within an order of magnitude above the triple point to the point where the ice melts and stabilizes as a liquid.
- 3) Liquid water can be withdrawn from the container under pressures within an order of magnitude of Mars pressure by creating a pressure differential in which the collection point is at a lower pressure than the formation pressure.
- 4) The withdrawal process can be performed successfully by maintaining the collection pressure above the triple point.

A mixture of ice and silica beads (1:1 mass ratio) was placed in a transparent cylindrical container, open at the top, made of Lexan with a length of 8 cm and a diameter of 7.6 cm (Fig. 2.) The bottom of the container consists of a metal perforated plate with a flexible, perforated Teflon membrane with 600  $\mu\text{m}$  pores allowing liquid water to pass and be withdrawn from outside the chamber. The simplicity and flexibility of the configuration allowed to change operational parameters based on direct observations of the behavior of the icy mixture via a viewport of the chamber (Fig. 3.)

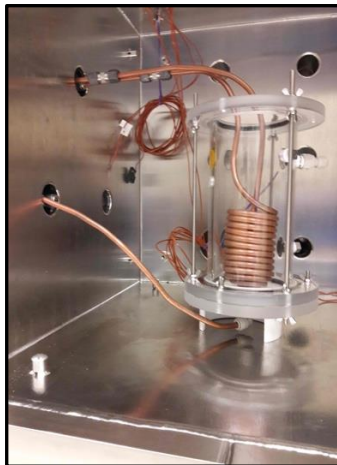

Figure 2. Processing container for Mars Liquid Water Extraction in chamber.



Figure 3. Liquid water forming and pooling at 80 torr and 3°C from ice introduced under Mars surface conditions

Despite some losses of water during incidental events, the experiment was successful in demonstrating the feasibility of melting all of the ice introduced and demonstrating the collection of the liquid water through a membrane system using a modest pressure differential between the chamber and the Mars ambient pressure. In further experiments, the processing pressure can be lowered to 15-20 torr and a better design for heat conduction into the ice will improve the control of the test conditions and establish the minimum requirements of pressure and heat inputs for the optimal melting and collection of liquid water. Lastly, the experiment will be conducted with regolith simulants that represent Mars soil materials representative of the locations where ice is inferred from Mars remote sensing data. Silica beads were selected as an inert control material with a similar thermal behavior than that of silicates in regolith.

## B. SCALABILITY OF MARS LIQUID WATER EXTRACTION SYSTEM FOR ICY REGOLITH

The capability of producing liquid water via melting under pressure conditions only a few torr above Mars ambient pressure and collecting it into storage without changing this environment could change our vision of large scale water production on Mars. The experiment we conducted was also designed to show that the removal of the liquid water could be achieved without opening the chamber and without changing

the value of the chamber pressure appreciably. In fact, the withdrawal operation only caused the chamber pressure to decrease by less than 0.5 Torr as recorded by the chamber sensors. This important finding demonstrates that a well-controlled withdrawal of the liquid water while maintaining pressure above the critical point through a small conduit can be done in a continuous manner on Mars without disturbing the processing environment. This is important for scaling the process to the production of large amounts of water, which we envision could follow the process flow diagram in Figure 4.

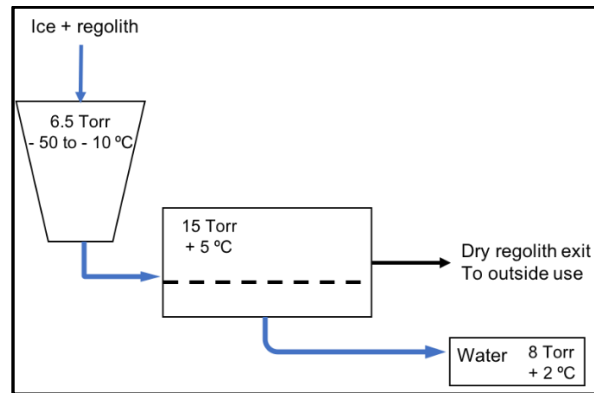

Figure 4. Process flow for extraction of liquid water from Mars ice - regolith mixtures. Values for processing conditions are notional.

Although the concept was demonstrated successfully at small scale in the laboratory, its potential would be fully realized when the volumetric accumulation of liquid water is large enough that it can be continuously drawn and stored using a permanent pressure differential controlled by the ambient Mars pressure. A preliminary design of such operation has been produced by adapting the principles involved in terrestrial rotary vacuum drum filtration.

### C. PLANETARY MOBILE MINING BUCKET DRUM AND ENVIRONMENT SIMULATOR TEST CELL

Water extraction from icy regolith can be performed on board an excavator at the excavation site or the regolith/ice mixture may be transported to an extraction plant where water would be removed from the regolith, then the spent regolith would be moved to a refuse site. Trade studies show that both make sense depending on the distance between the excavation sites and the water extraction plant, as discussed in the previous section. This project investigated water removal at the excavation site performed inside the drum of a bucket drum excavator such as a modified Regolith Advanced Surface Systems Operations Robot (RASSOR) developed at NASA Kennedy Space Center Swamp Works.

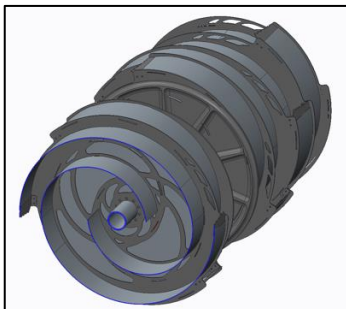

Figure 5. Cross-sectional view of RASSOR 2.0 drums.



Figure 6. Bimetallic hinged door concept open (left) and sealed (right).

A bucket drum is a unique excavator (Fig. 5) that is well suited for on-board water extraction since the scoop openings on the regolith ore-filled drum can be sealed, which then provides a closed vessel in which the water vapor can be trapped and collected by a cold trap water condensation system for further



downstream processing into ISRU products. A concept was developed using the RASSOR 2.0 excavator bucket drums as an enclosed water extraction tank by sealing the digging scoops with a bi-metallic temperature actuated flap (Fig. 6.) By tumbling the regolith while heating it, the water can be extracted and then captured in a separate downstream cold trap vessel, and it may also be possible to use the energy efficient solid to liquid only phase transition mode to also extract water using a modified bucket drum. More bench top experiments are needed to validate these concepts.

Regolith transfer to a separate system is avoided, resulting in higher reliability, lower losses and lower system mass. Power is assumed to be provided by an on-board battery system that is periodically recharged at a power management and distribution station that is connected to a deployed “NASA kilowatt design” fission power plant. A bench top test apparatus was designed to demonstrate the feasibility of on-board bucket drum water extraction as shown in Figure 7.

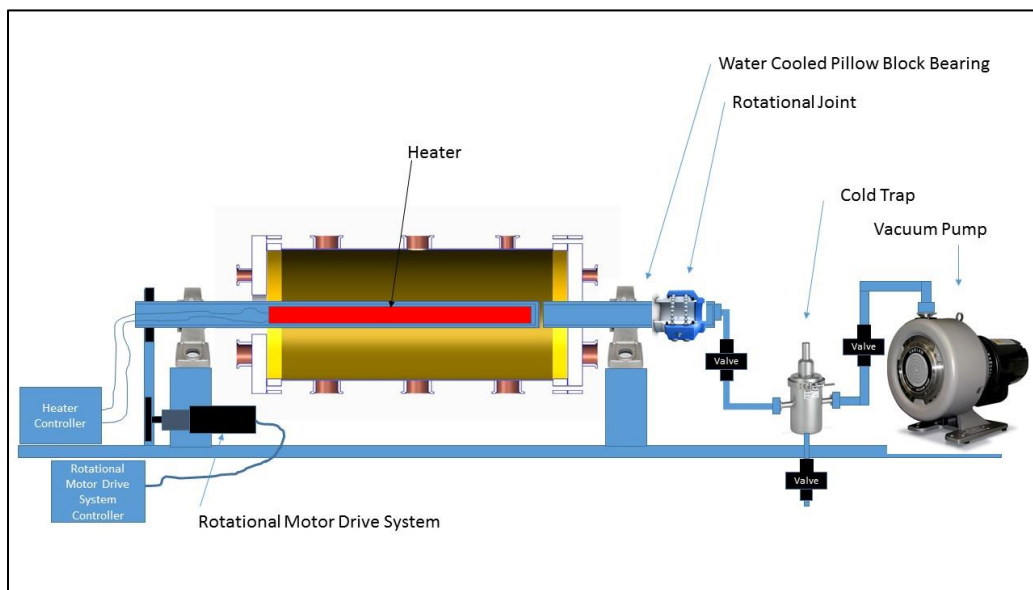

Figure 7. Functional design of the bucket drum environment simulator.

The test stand simulated a bucket drum with a resistance heater installed in the axis of the drum. The regolith ore is tumbled inside the drum as it is rotated so that the regolith particles are constantly overturned and exposed to the heat transfer modes of the resistance heater. Typically, regolith in a soft vacuum would act as a good insulator, but since the regolith is tumbled, heat transfer efficiency is promoted and accelerated, making the water extraction operation more feasible in a reasonable time period, with lower energy consumption. Additional features such as baffles along the rotating axis are not depicted in Figure 7. It is also important to note that these concepts can accommodate a variety of heating techniques devices to increase water extraction efficiency. Due to NASA procurement processes and vendor lead times, the test cell fabrication was performed during the project but was not delivered to NASA Kennedy Space Center in time to perform water removal testing. All parts were ordered and are available for assembly.

**Technology Maturation Opportunities:** R. Mueller and L. Sibille are pursuing further funding to build on the initial success of this low TRL investigation. Communication is proceeding with the NASA ISRU project to gauge interest in continuing this work as part of the NASA ISRU technology development portfolio with lunar applications.

**Partnerships:** We also wish to acknowledge our collaborator, Dr. Kris Zacny of Honeybee Robotics, Inc. who provided valuable advice and data.

## **17-5. Work Execution for Integrated Display and Environmental Awareness System (WeIDEAS)**

**PI:** Ruiz, Kelvin, Kelvin.R.Ruiz@nasa.gov

**Primary TA** TA 13, TA 4 and TA 7

**Start TRL** TRL 5 / **End TRL** TRL 6

### **Goal / Gap**

In the previous two years, the Early Career Initiative (ECI) IDEAS team, worked in the development of Hardware and Software for head mounted displays and smart glasses, for operations on earth and space. This year as a Center Innovation Fund (CIF) activity, the goal was to continue to increase the Technology Readiness Level of this technology by moving from the laboratory, into the field, focusing on the procedure execution piece of the IDEAS software suite. Existing procedure software available off-the-shelf, has been developed specifically for use on devices such as laptops and tablets but not for smart glasses. JSC, and KSC have independently developed procedure software that is compatible with Smart-Glasses wearable devices. This project proposed to take the technology developed and make it compatible with both COTS and custom procedure software. In addition, this will be the first smart-glasses device that is compatible with the systems currently in use by ground operations at KSC.

### **Approach / Innovation**

This project is a follow-on to the software portion of the IDEAS project. In this project we are furthering the development of the procedure (Atlas-Work) component of the IDEAS software suite. This advancement would make the procedure application compatible with ground operations procedures from existing tools, as well as making it compatible with the Procedure Representation Language (PRL) developed at JSC.

#### Project Plan / Schedule

1. Familiarization with Solumina and PRL XML Schemas (2 months)
2. Development of Solumina / Atlas-Work import/export capability (4 months)
3. Development of PRL import/export capability (4 months)
4. Testing of IDEAS software suite with advanced Atlas-Work in a relevant ground operations environment (2 months)

Final deliverable: IDEAS Software Suite running on an Android Operating System-compatible Smart Glasses device. Suite would be running the improved Atlas-Work app as described above. This app would, in addition, be able to send relevant telemetry from the procedure to the IDEAS Console application.

### **Results / Knowledge Gained**

1. Familiarization with Solumina and Procedure Representation Language (PRL) XML Schemas
  - a. This activity was fully completed by the team. We have familiarized ourselves with the XML Schemas from both the Solumina software use in ground operations at KSC and the PRL software used by JSC.
2. Development of Solumina / Atlas-Work import/export capability
  - a. Successfully developed the capability of importing procedures from Solumina into the IDEAS software and executing those procedures.
3. Development of PRL import/export capability
  - b. Successfully developed the capability of converting PRL procedures into a format that is compatible with IDEAS and executing those procedures from within the IDEAS software.



**Figure 8 Procedure as seen from the user's perspective**

4. Testing of IDEAS software suite in a relevant ground operations environment
  - c. Successfully executed procedures in a ground operations environment. The IDEAS team worked with the Ground Systems Development and Operations program and executed a procedure for the preparation of the Gaseous Helium (GHe) service cart. The procedure was executed properly and the software and hardware performed as expected.



**Figure 9 Technician performs operation following procedure displayed on the IDEAS hardware/software**



**Figure 10 Ground Operations Technician wearing IDEAS compatible Smart Glasses**

### **Additional Accomplishments**

In addition to the goals discussed, the team also continue to improve the technology in several ways including requested features from the stakeholder panel. These features included:

1. Text-To-Speech – This software feature will read the procedure steps to the user through the built-in headphones of each device.
2. Remote Console Improvements – Developed a “Detailed View” on the console software which provides the remote console operator additional information from each field user, including the exact procedure step the field user is currently executing.
3. Message Queue – If the user in the field is in an area with no network coverage, the device will automatically queue outgoing messages and will transmit them once the device is back online connected to the network.
4. File Transfer – A remote console operator can send files to the user wearing the head mounted display. This includes documents, pictures and procedures. With this feature the use can receive new procedures on-demand without returning to the office area.
5. Bug Fixes – The team improved the general stability of the software package.

### **Technology Maturation Opportunities**

To continue the maturation of this technology we need to work closely with other programs to develop real-life use cases that will validate the usefulness of this technology in real-world scenarios. The technology has been very well received during our exercises in a relative environment, which in our case was during a ground operation at KSC. More of these use cases should be developed and executed. We have been approached by other NASA Centers and programs and they would like to utilize our technology for their operations and maintenance activities.

### **Partnerships**

1. Lui Wang of JSC, who is the expert on the JSC developed PRL.
2. Ground Operations team of the Ground Systems Development and Operations program at KSC.