



Geometry and Joint Systems for Lattice-Based Reconfigurable Space Structures

Megan Ochalek¹, Olivia Formoso², Greenfield Trinh², Ben Jenett³, Kenneth Cheung²

¹Massachusetts Institute of Technology, Cambridge MA, ²NASA Ames Research Center, ³Center for Bits and Atoms, MIT

ABSTRACT

We describe analytical methods for the design of the discrete elements of ultralight lattice structures. This modular, building block strategy allows for relatively simple element manufacturing, as well as relatively simple robotic assembly of low mass density structures on orbit, with potential for disassembly and reassembly into highly varying and large structures. This method also results in a structure that is easily navigable by relatively small mobile robots. The geometry of the cell allows for high packing efficiency to minimize wasted payload volume while maximizing structural performance and constructability. We describe the effect of geometry choices on the final system mechanical properties, manufacturability of the components, and automated robotic constructability of a final system. Geometry choices considered include building block complexity, symmetry of the unit cell, and effects of vertex, edge, and face connectivity of the unit cell. Mechanical properties considered include strength scaling, modular loading, and structural performance of the joint, including proof load, shear load, mass, and loading area; as well as validation and verification opportunities. Manufacturability metrics include cost and time, manufacturing method (COTS versus custom), and tolerances required. Automated constructability metrics include local effects of loads imparted to the structure by the robot and assembly complexity, encompassing the ability of the robot to clamp and number of placement motions needed for assembly.

OBJECTIVES

- Research, design, and test different connection types for ease in robotic assembly
- Evaluate unit cells to determine optimal geometry
- Design and implement a robotic end effector for mechanical fastening of the lattice

Image from NASA.gov

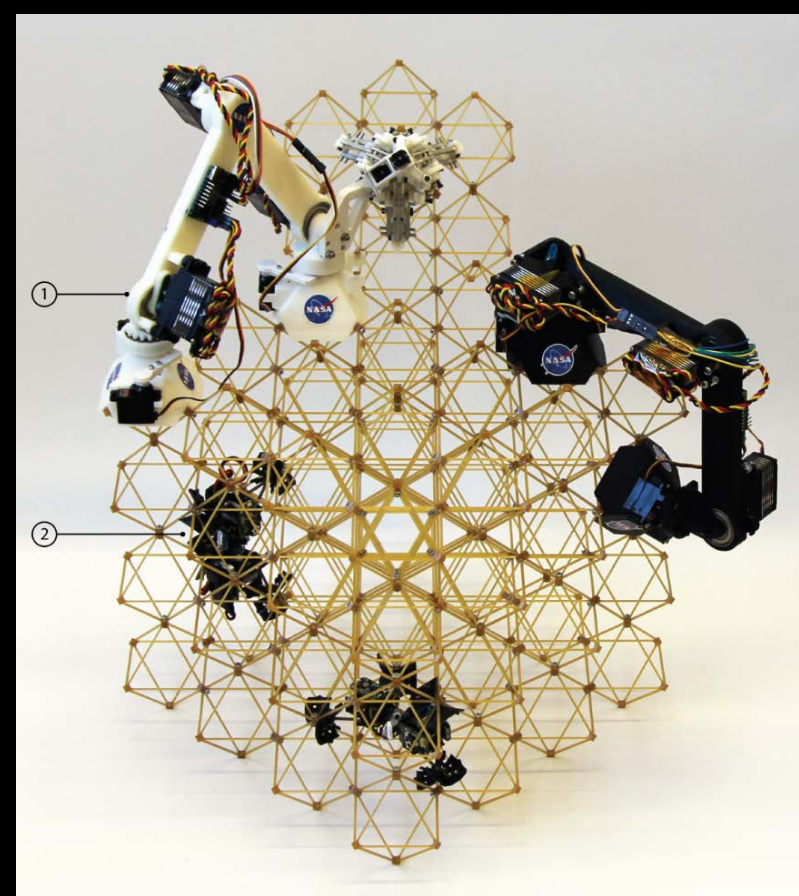

METHODS

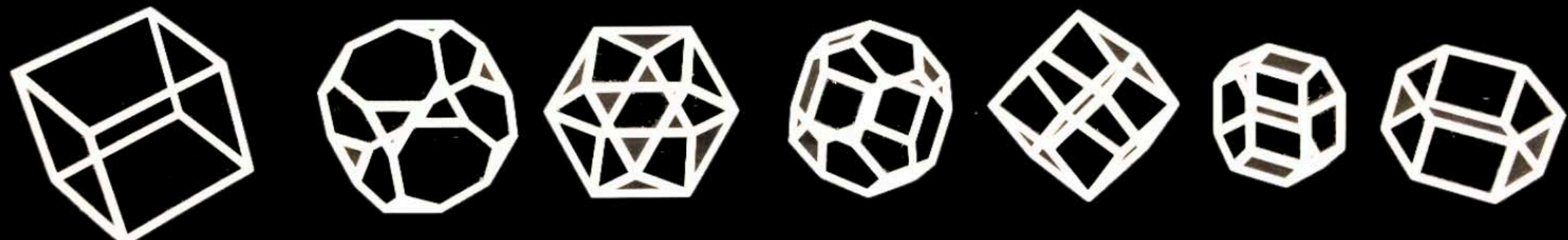

Examples of the unit cells examined, from left to right: cube, truncated cube, cuboctahedron, truncated octahedron, rhombic dodecahedron, elongated rhombic dodecahedron, and hexagonal prismatic

We evaluated a variety of unit cell geometries to determine which would best suit our requirements of structural performance and mechanical ability to be assembled. Additionally, for each lattice geometry, we evaluated the effects of the selected *adjacencies* – here, defined as a neighboring voxel; adjacency type can be face, edge, or vertex – and *attachments*, which occur between the base voxel and the adjacency.

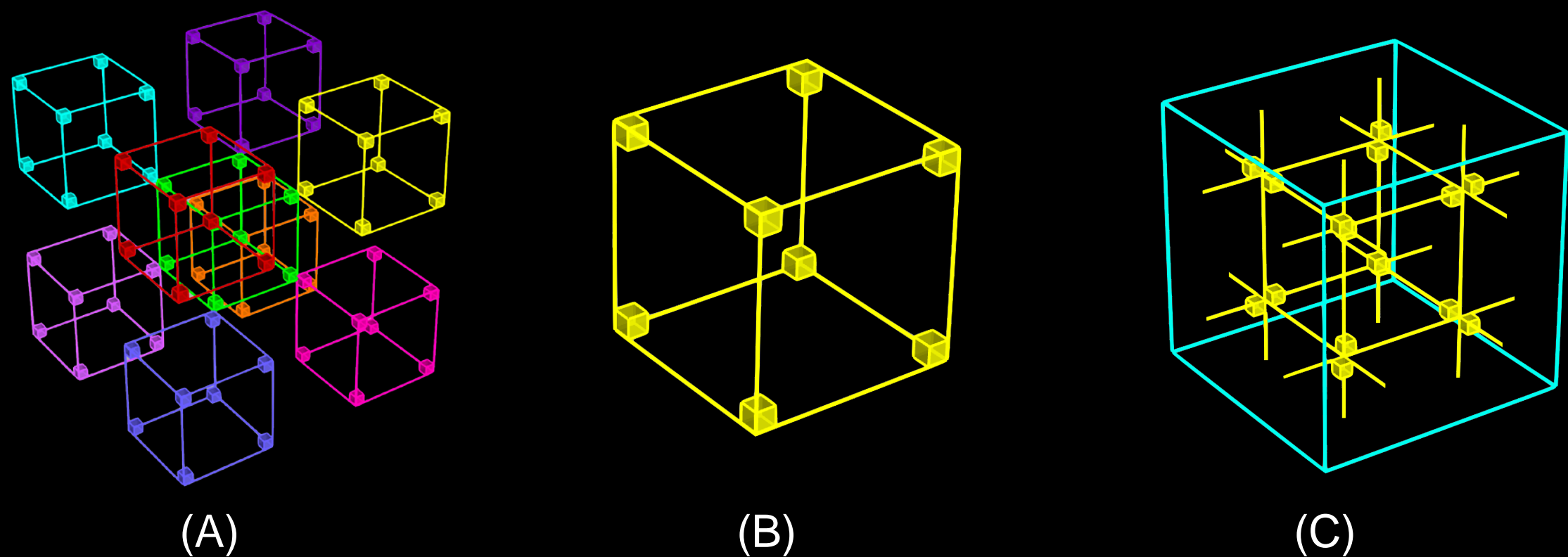

(A) cubic lattice with vertex adjacencies and attachments; (B) the cube unit cell; (C) the unit repeating volume

RESULTS

- Mechanical fasteners outperform others options for assembly, disassembly, and reassembly in a space environment
- Feeding of mechanical fasteners proves quite difficult for robotic assembly; the use of captive fasteners overcome this challenge
- Cell geometries with a higher number of attachments per each adjacency – commonly found with “smaller” adjacencies, such as vertex – increase significantly in complexity

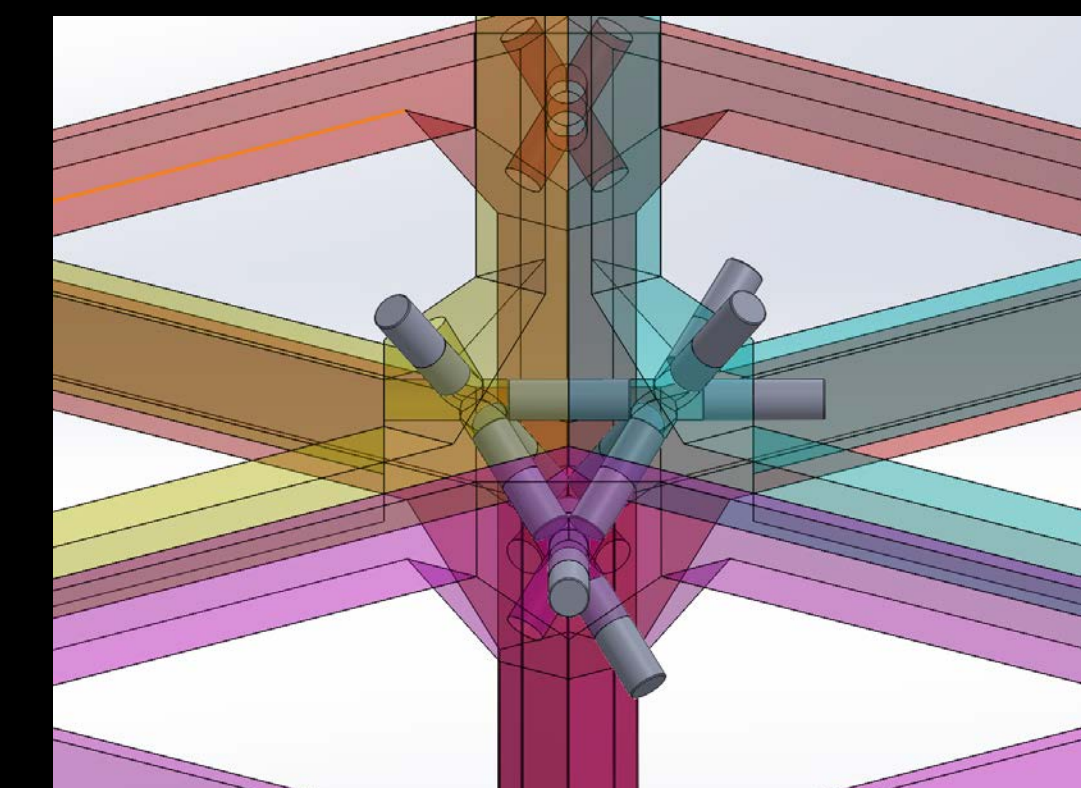

A captive mechanical joint for a cubic lattice with edge adjacency and vertex attachment.

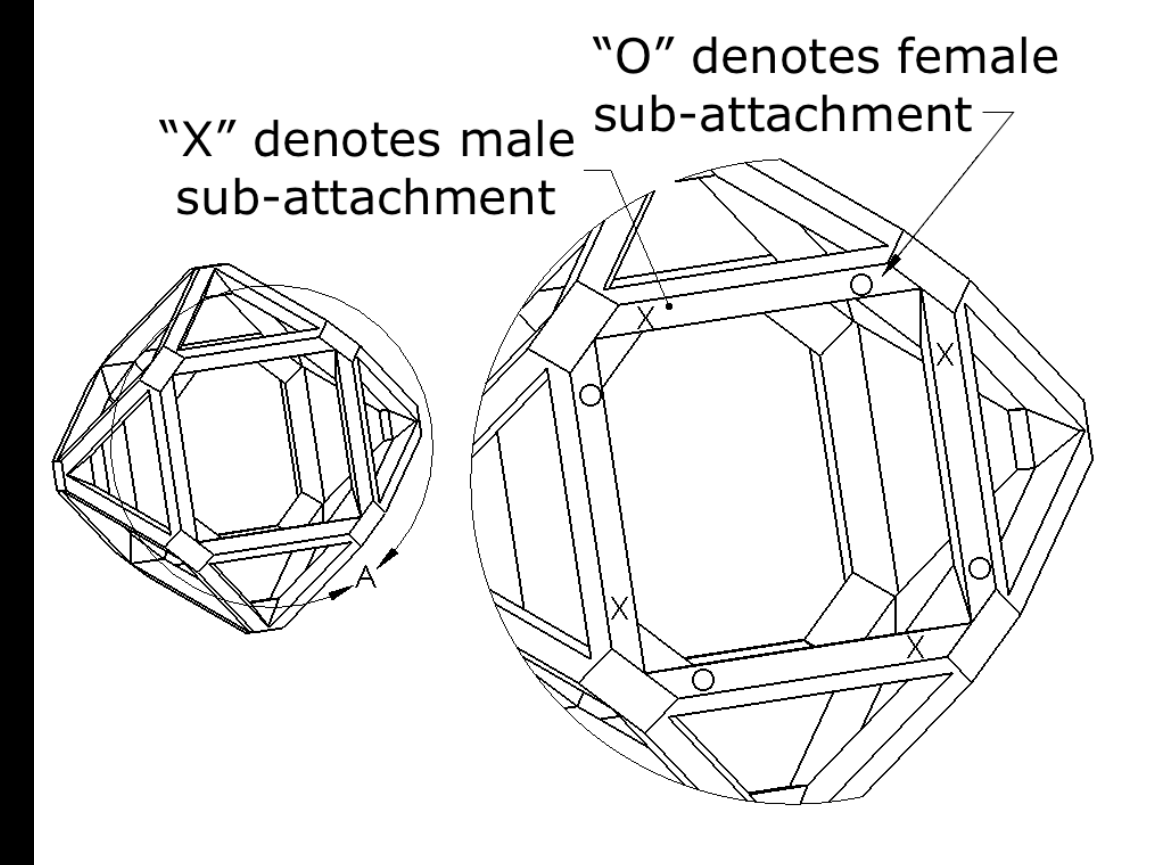
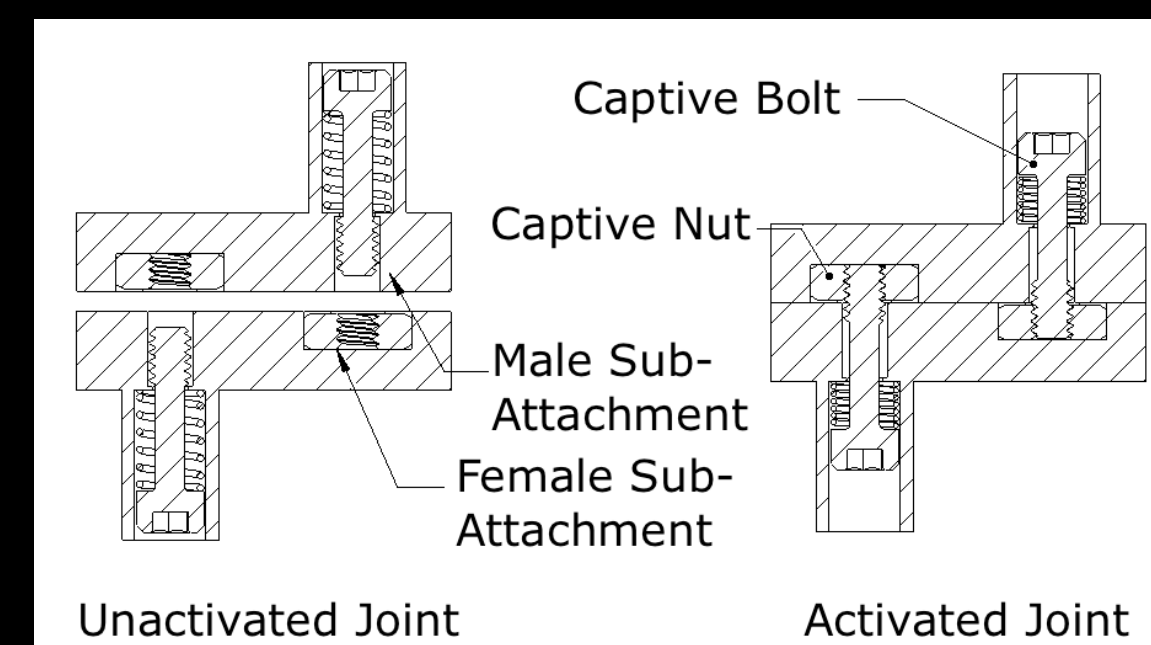
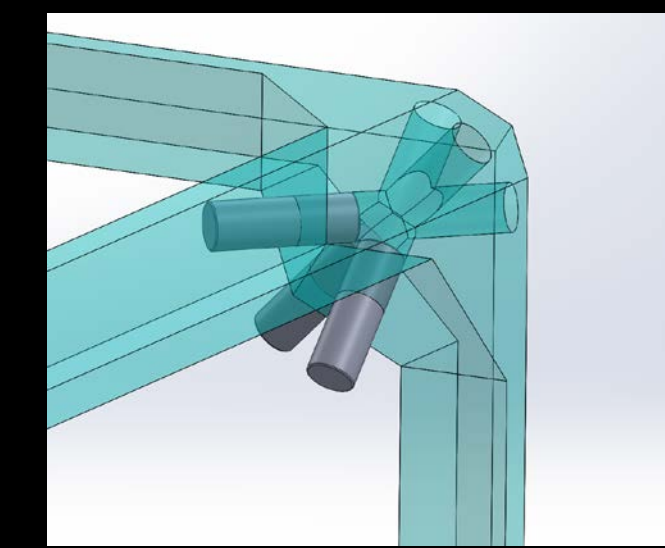

Left: ACF prototype with no unused fasteners; example of integration into face adjacency
Below: androgynous captive fastener (ACF) prototype;
Bottom: sizable material difference between prototypes

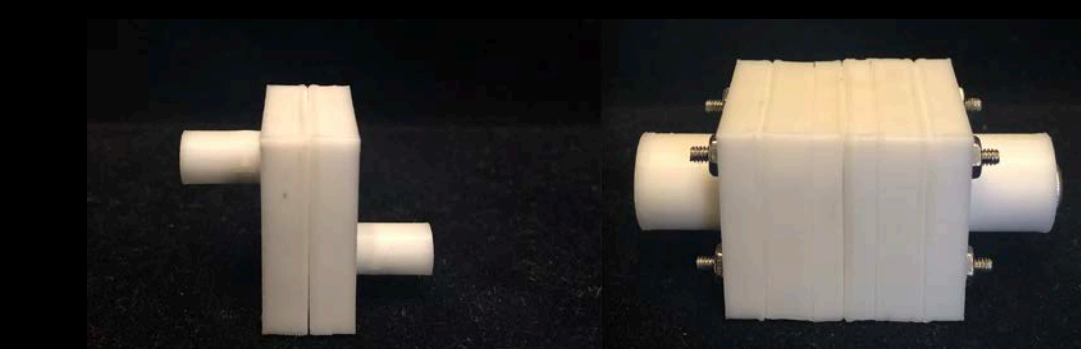
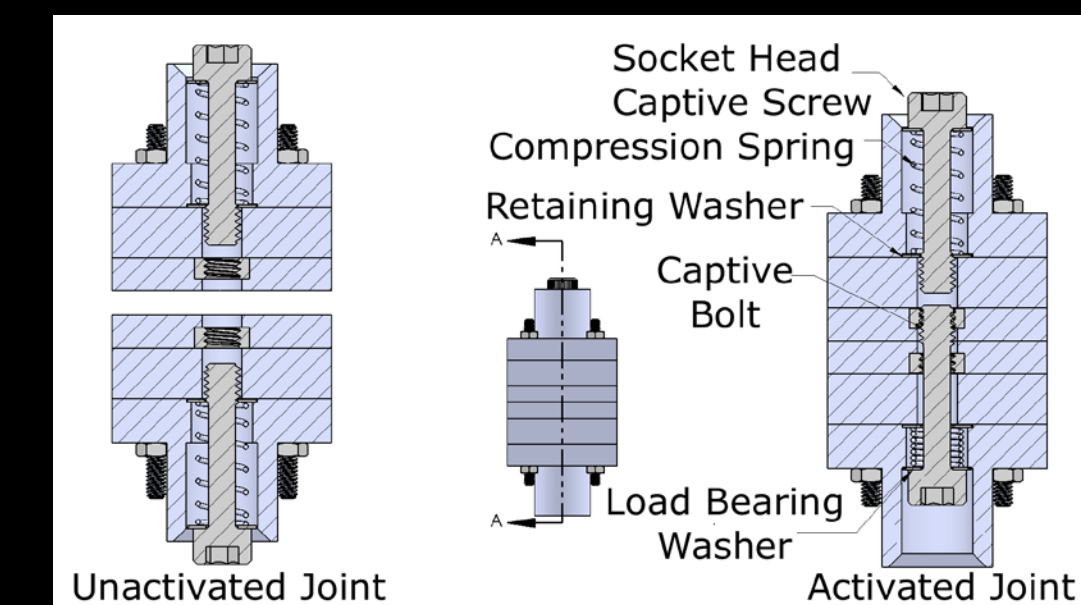

FUTURE WORK

- Select final geometry for unit cell using determined metrics
- Determine optimal adjacency and attachment combination for maximized robotic assembly efficiency and ease
- Integrate joining method into chosen unit cell geometry
- Design, fabricate, and test robotic end effector for fastening assembly; integrate into relative robot

ACKNOWLEDGEMENTS

I would like to thank my amazing mentors, Olivia Formoso, Greenfield Trinh, and Ben Jenett, along with everyone in the Coded Structures Laboratory, for helping me throughout the summer, with a special shoutout to Kenny Cheung. Thanks also go out to NASA Ames Research Center for this wonderful opportunity.