

SPHERES

Synchronized, Position, Hold, Engage, Reorient,
Experimental Satellites



SPHERES/Astrobee Working Group (SAWG) Quarterly Meeting

Jun 19th, 2018





Agenda

SPHERES/Astrobee Working Group		Join by phone 1-844-467-4685; 226968					
Draft, Subject to change							
Date:	June 19th, 2018, 9am PST	In-Person, Stanford, Room: Durand 450 (https://asl.stanford.edu/contact)					
Agenda	Group	Project	Name	Time	duration (min)	In-Person?	Attendance
0	NASA Ames/Stanford	Introductions	Marco Pavone	8:50 AM	0:10		
1	NASA HQ	AES Program Welcome	Andres Martinez	9:00 AM	0:05	yes	1
2	NASA Astrobee	SPHERES Facility Status	Jose Benavides	9:05 AM	0:20	yes	10
3	NASA ISS	SPHERES PIM Status	Melissa Boyer	9:25 AM	0:15	no	
4	NASA Astrobee	Astrobee Overview and Status	Maria Bualat	9:40 AM	0:20	yes	5
5	NASA ISS	Astrobee PIM Status	Larry Cotton	10:00 AM	0:15	no	
6	NASA ISS TDO	NASA ISS Program TDO overview	Dave Hornyak	10:15 AM	0:10	no	
7	CASIS	CASIS Overview	Jennifer Lopez	10:25 AM	0:10	no	0
8	Break			10:35 AM	0:15		
9	MIT	SPHERES SmoothNav, ReSwarm, Zero Robotics	Alvar Saenz-Otero	10:50 AM	0:30	yes	1
10	Airbus	SPHERES Tether Slosh	Hans Zachrau	11:20 AM	0:15	no	
11	Lunch			11:35 AM	1:00		
12	NASA Logistics	REALM-2	Andrew Chu	12:35 PM	0:20	no	
13	Astrobotic/Bosch	Deep Audio Analytics	Fraser Kitchell	12:55 PM	0:20	no	0
14	Stanford	Gecko-Inspired Adhesive Appendages for Automated Logistics	Marco Pavone	1:15 PM	0:20	yes	5
15	NPS	Propellantless mobility for spacecraft	Marcello Romano	1:35 PM	0:20	yes	4
16	FIT	RINGS/SVGS	Hector Gutierrez	1:55 PM	0:20	yes	1
17	Break			2:15 PM	0:15		
18	NMSU	MPC Control of Astrobee	Hyeongjun Park	2:30 PM	0:15	yes	2
19	Tethers Unlimited	AstroPorter	Nathan Britton	2:45 PM	0:15	yes	2
20	PRISMS	Princeton International School of Mathematics and Science	Gregory Herman	3:00 PM	0:15	yes	2
22	NASA Ames	Wrapup, Action Items	Jose Benavides	3:15 PM	0:15		
23	Stanford	Lab Tour	Marco Pavone	3:30 PM	0:30		
		Depart		4:00 PM	0:00		4
						Total:	37



SPHERES Community

□ SPHERES Working Group (SWG) Quarterly meeting

- Membership includes MIT, FIT, AFS, DARPA, CASIS, Airbus, and NASA (HQ, KSC, JSC, MSFC, and ARC)
- Face-to-Face, twice a year
- Next will be scheduled in May 2018, location TBD

□ Purpose:

- Information sharing across the SPHERES/Astrobee community
 - Astrobee Facility shares
 - ✓ National Lab Facility availability
 - ✓ Status of resources (batteries, CO2 tanks, etc.),
 - ✓ Overall Calendar (scheduled Test Sessions, upmass/return), and
 - ✓ Updates on “new” PD, Investigations, and ISS infrastructure.
 - Provide the SPHERES/Astrobee community (PD, investigators, etc.) with up-to-date information to determine opportunities to use the NL Facility
 - Discuss proposed changes/updates to Astrobee Nat Lab which may be required to support a specific activity or research.
 - Discuss specific support requests made to the ISS Office
-



Today's Goals

□ The SPHERES/Astrobee Facility success as a platform for technology development and fundamental research depends on the success of it's users

- What's your current goal with Astrobee? (Lab Demo? ISS Demo?)
- Plan for getting there
- Are there some make-sense partnerships with other groups here?





Guest Science Program (GSP)

- ❑ **What's available from the Astrobee Facility?**
 - ❑ Astrobee Robotics Software Simulation
 - ❑ Ground Hardware: Qty 3 & "Flat-Sats"
 - ❑ Labs: Granite & MGTF
 - ❑ Documentation and Training
 - ❑ Proposal Support
 - ❑ ISS Payload Partner
- ❑ **How can I use Astrobee and what does it take?**
 - ❑ **Guest Scientist Guide** & Mechanical Payload ICD
 - ❑ New Hardware or "just" Software?
 - ❑ Ground Demonstration or ISS Operation?
- ❑ **We want to hear from you!**
 - ❑ Approximate Scheduling
- ❑ **Information found on website**
<https://www.nasa.gov/astrobee>



What's next ...

- ❑ Next ZR competition is under way
- ❑ Continuing Vertigo Smooth Navigation research
- ❑ Continuing Tether-Slosh
- ❑ Continuing SPHERES-ReSWARM
- ❑ **Continue work transitioning to Astrobee**
 - ❑ Goal: Fully operational in 2019
- ❑ Astrobee and Int-Ball joint-activity discussions continuing
- ❑ Interns (Matt, Ruben, Cole, Vivek, Peter, Bryce)
 - ❑ Zero Robotics
 - ❑ GSP Software
 - ❑ Astrobee Build
 - ❑ Air Sampling on ISS

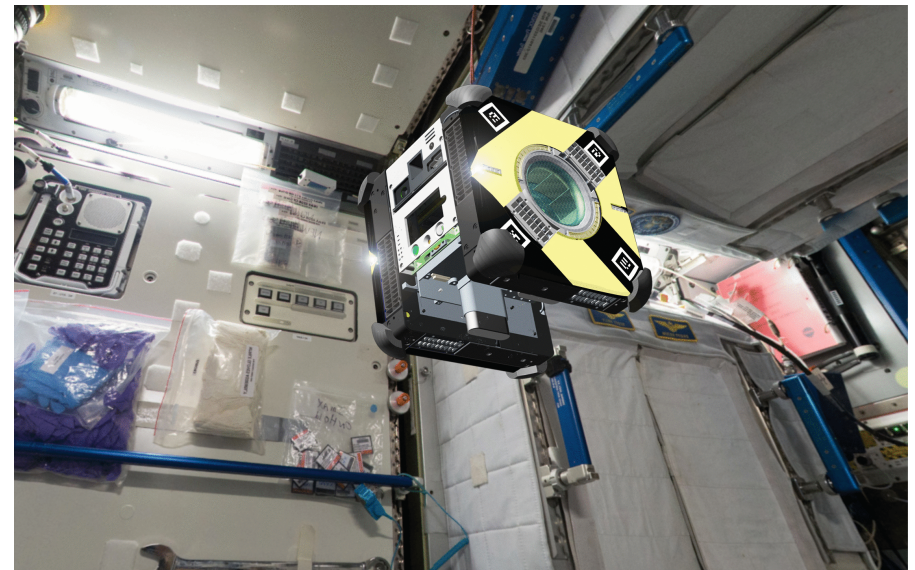



Guest Scientists

- ❑ Replacing SPHERES, it is anticipated that Astrobees will carry on as the **most highly utilized payload on the ISS**
- ❑ **40+ projects have expressed interest in using Astrobees**
 - Topics range from 0g fuel tank slosh to propellantless flight via acrobatic arm motion
- ❑ **7 Projects actively working towards ISS payloads**
 - MIT/Zero Robotics
 - Naval Postgraduate School
 - Astrobotic/Bosch
 - Stanford
 - REALM
 - JAXA joint activity
 - [Port Tester]

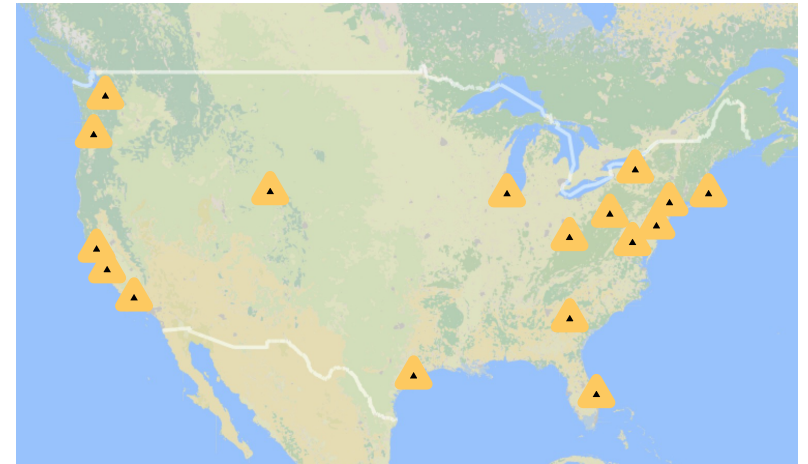

Astrobees guest scientist institutions in the US

- ❑ **Ground Studies**
 - FIT/RINGS
 - Tethers Unlimited
 - NMSU



Guest Science Concepts

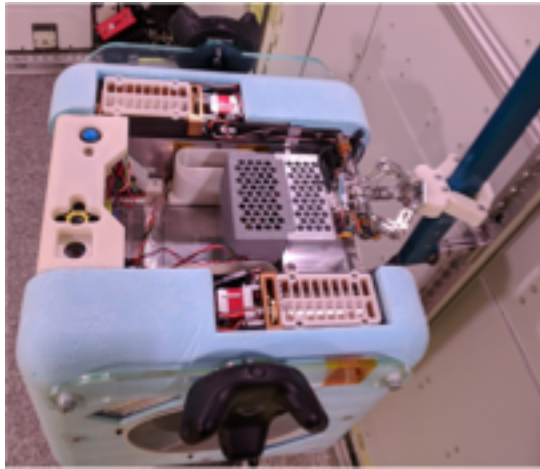

Prototype Astrobees arm based on Canfield joint, enabling new motions (Tethers)

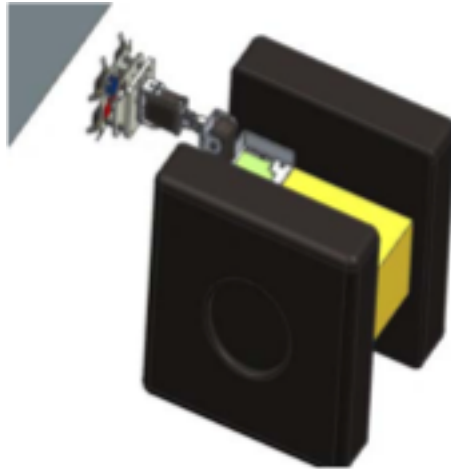

Gripper concept based on gecko-like adhesives (Stanford)

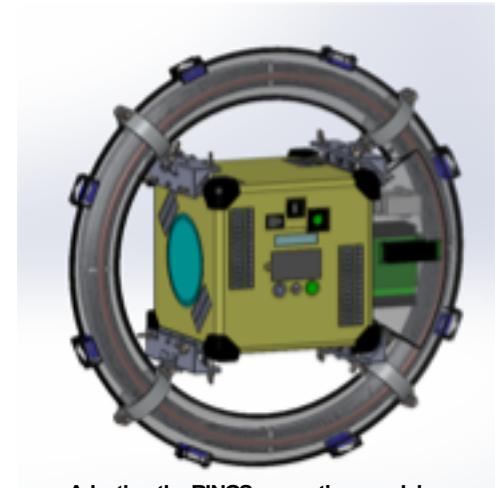

Adapting the RINGS magnetic propulsion payload to Astrobees (FIT)

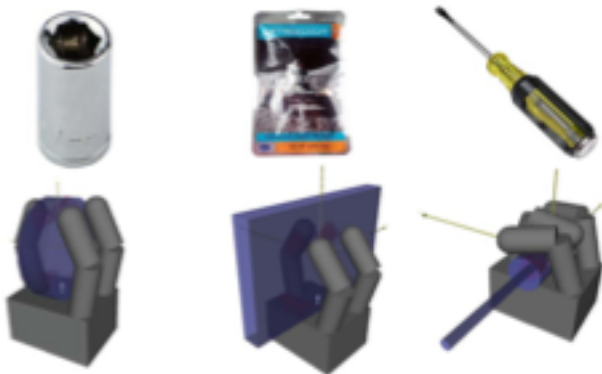

Improving gripper dexterity without increasing actuator count (Columbia)



Arm grasping controller developed using Astrobees open source simulator (NPS)

and many more...



SPHERES Engineering



Ground Lab Status

- Granite Lab: Online

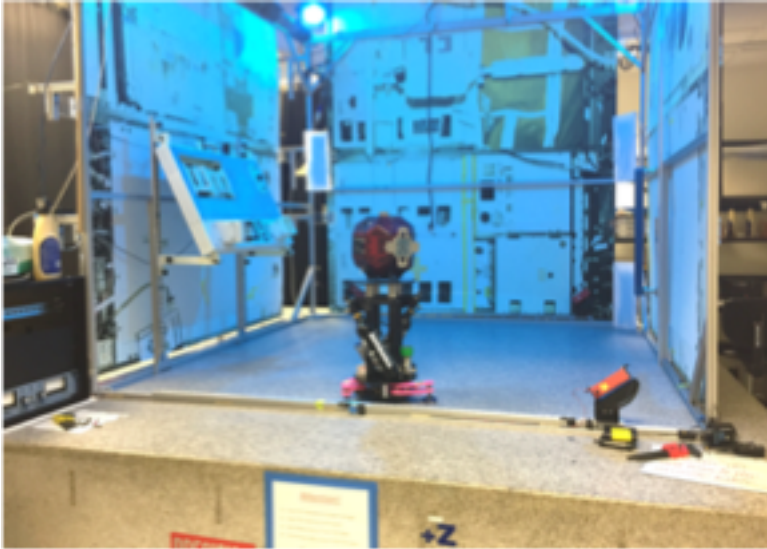

- Flight Lab: Online



- Micro Gravity Test Facility (MGTF) Lab

- Engineering Evaluation Lab (EEL): Available upon request



Hardware Fidelity (Astrobee)

Name	Mechanical Fidelity	Electrical Fidelity	Software Fidelity	Sensor Fidelity
P4C	Low	Low	Low	High
P4E	Med	Med-High	High	High
Flat Sat A	Low	High	High	Low/None
Cert	High	High	High	High
Flight 1	High	High	High	High

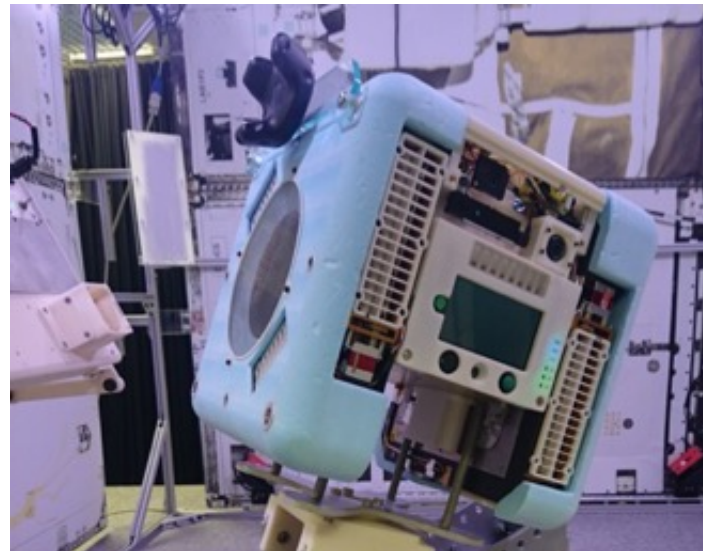
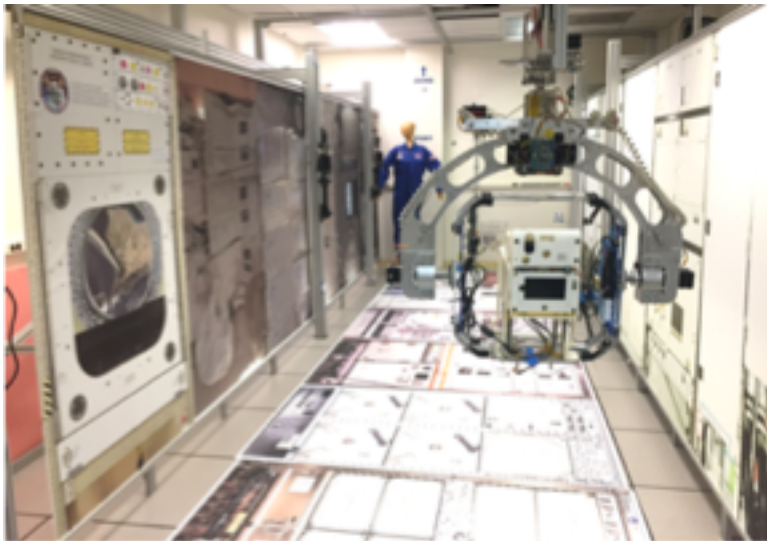



Hardware Status (Astrobee)

Name	Status	Plans
P4C	End-Of-Life	Available in MGTF but unsupported
P4E	Operational	Dev. Testing in Granite until Cert, then MGTF
Flat Sat A	Operational	In use by FSW team
Cert	Complete	Debugging, then verification testing
Flight 1	In-Work	Complete by 08/17, then verification testing

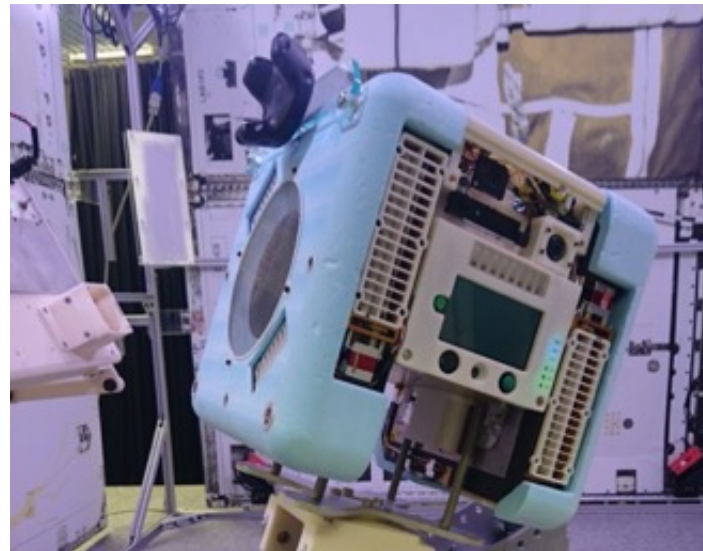



Port Tester

Andres Mora

S/A Facilities



Port Tester Payload

- ❑ **Facilitates diagnostics of Astrobee's internal USB ports**
- ❑ **Tests safe electrical current operational limits**
- ❑ **1U design to fit within Astrobee's payload bays**
- ❑ **Includes both hardware and software development:**
 - Structure, electronics, supports, interfaces
 - Port tester's human and Astrobee interfacing programs and HLP Guest Science APK
- ❑ **Connection with Astrobee through HLP Guest Science APK**

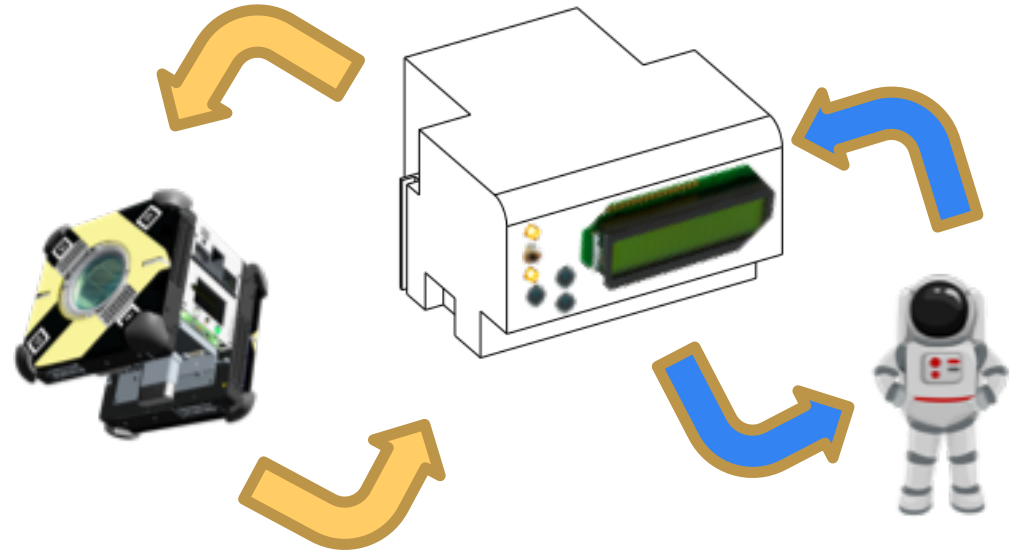



Port Tester Payload

□ Composed of two main boards:

- Face board:

- ✓ 140 mm x 75 mm
- ✓ handles interaction with astronaut (includes buttons, LCD, switch, and USB port)

- Base board:

- ✓ 85 mm x 55mm
- ✓ handles interaction between payload and Astrobee

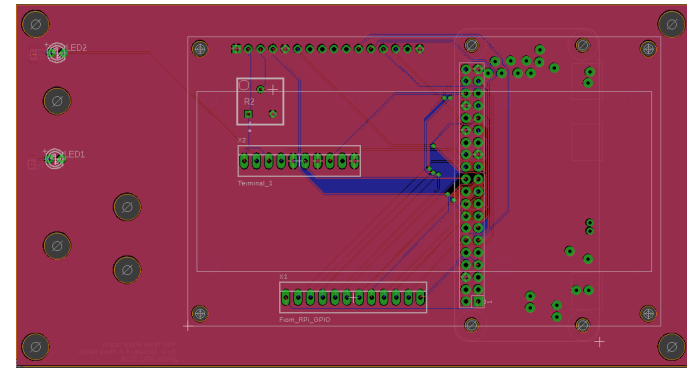

Face board prototype 1

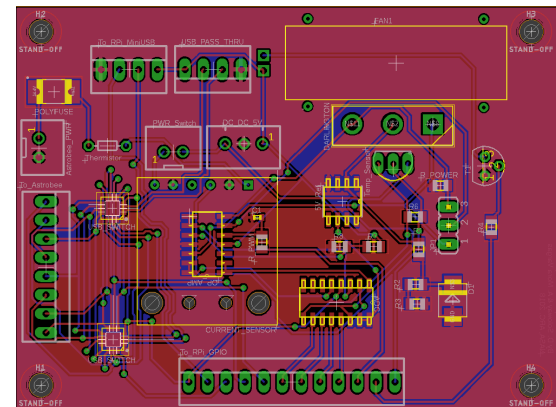

Base board prototype 1



Future Updates to Guest Science Guide

Ruben Garcia & Andres Mora

S/A Facilities



Guest Science Guide

- ❑ **Overview of the contents of the GS Guide document.**
- ❑ **Once SPHERES transition to Astrobee, a new GS Framework will be in place.**
- ❑ **The GS Guide is a compilation of concepts and guidelines to write GS applications in Astrobee.**
- ❑ **This document will contain:**
 - Fundamentals about Astrobee GS Development.
 - A step by step tutorial to build GS applications.



Guest Science Guide

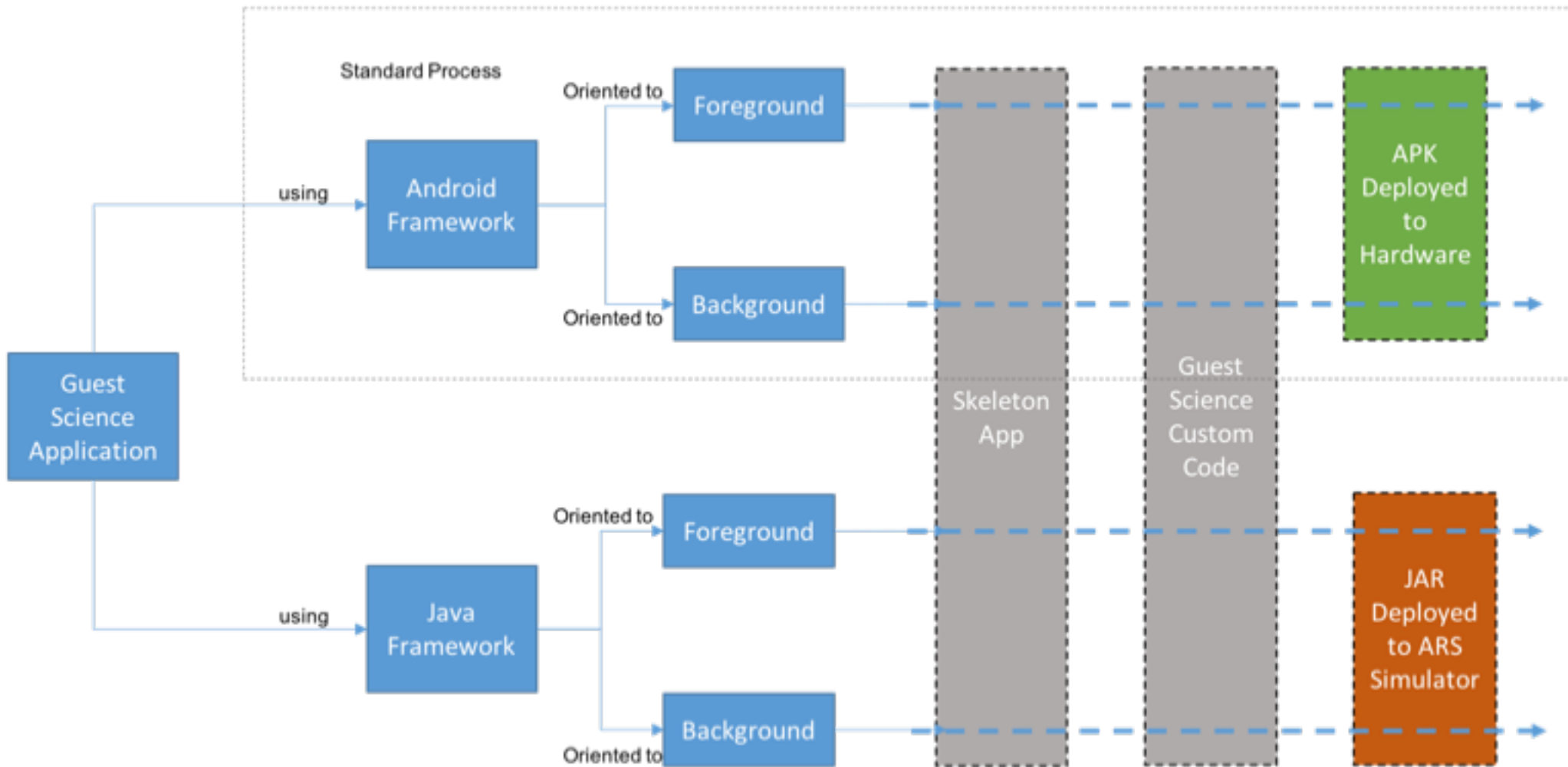



Guest Science High-level Development Steps

- ❑ High-level flow diagram of a GS application development

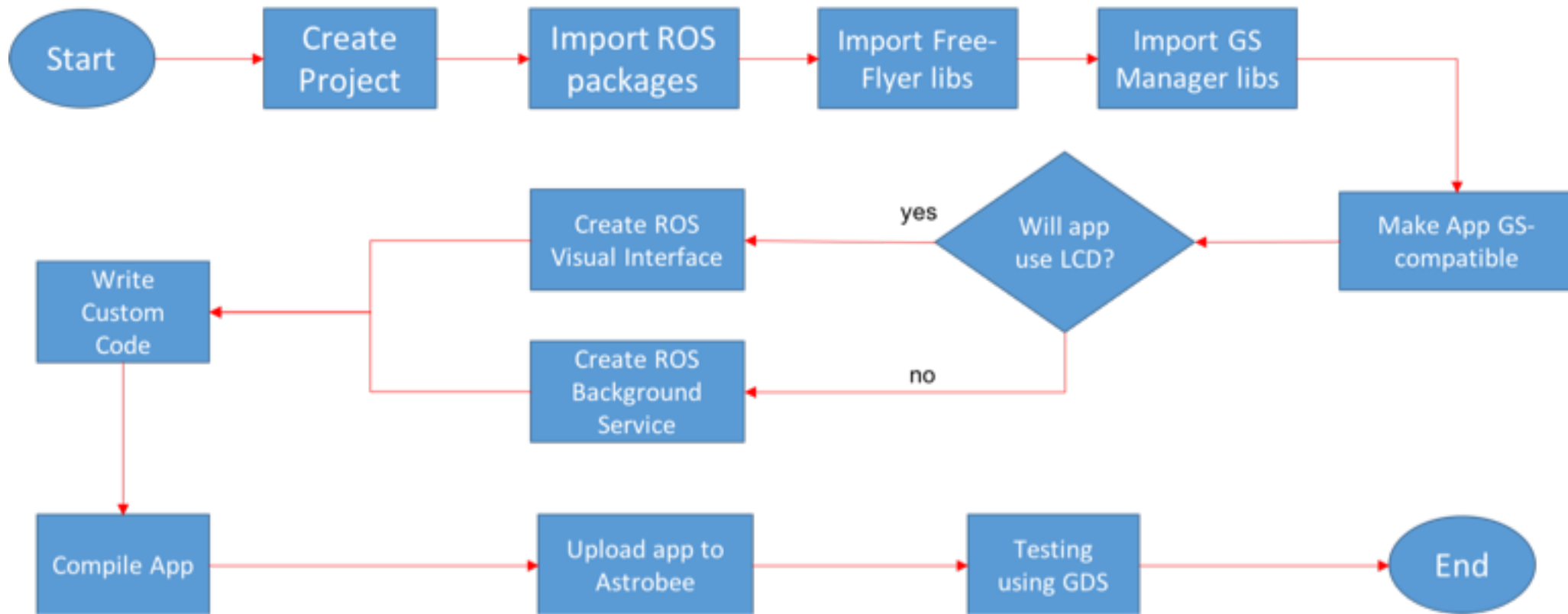



SPHERES & Astrobees Operations



Operations: Functions

Ensure Facility Readiness for ISS Test Sessions

- All crew training now via Onboard Training (OBT) both English & Russian
- Crew procedure updates
- Coordinate with ISS Lead Increment Scientist and POIC Cadre
- Flight products on orbit (test plan, .spf, on-board training and review, etc.)
- Consumables (CO2 Tanks and Batteries) refurbishment and resupply
- Support SPHERES directory/file maintenance

Real-Time ISS Test Session support

- Coordinate w/SPHERES investigators product development and delivery
- Support crew and POIC cadre real-time
- Conduct/coordinate crew conferences as needed
- Test session data and video management

Public Relations

- Maintain website, work with ARC PAO office to publish material on site
-



Operations: Functions

Increment Planning

- PTP and 2-pager development, and update & support and submittal
- Timeline planning model review and update

Safety and Verification Assessments

- Integrated Safety & Verification Assessments for all SPHERES payloads
- Safety & Verification assessments for Battery/Tank launches/returns
- Complete Certification of Flight Readiness for ground systems and on-orbit hardware and operations products
- Conduct ISS Requirements Change Assessments to SPHERES Facility

Astrobee Ground Ops Development

- On orbit Activity planning and development
- Ground Operations Readiness Test planning and development
- OBT (Onboard Training) videos being initiated



Increments 55/56 (since last SWG 2.28.18)

➤ Test Sessions

- **SmoothNav Science 2** **April 2, 2018**
 - **Tether Slosh Science 2** **April 4, 2018**
 - **SPHERES Rechargeable Battery Charge Activity** **April 24, 2018**
 - Awakened from deep sleep after ~1.5 years and charged for the first time
 - Some issues with getting the batteries to mate with the charging adapters but solved
 - These batteries will be used for the first time in SPHERES Satellites June 28, 2018.

 - **Updated flight procedures for Tether Slosh, SmoothNav, and updated all procedures to reflect the rechargeable batteries**

 - **Attended the Payload Operations Integration Working Group (POIWG)**
April 24-26 MSFC
 - Astrobee Splinter Meeting – Initial one-pager planning document presented

 - **Established initial Astrobee Operations Readiness Test (ORT) plan and timeline for all the Commissioning Activities**
-



Increments 55/56 & 57/58

- **Increments 55/56 (March 2018 – October 2018)**
 - **SPHERES Maintenance** June 28
 - **Tether Slosh Science 3** July 18
 - **Zero Robotics High School Units Test** late July 2018 date TBD
 - **Zero Robotics High School Dry Run** August 8
 - **Zero Robotics High School Finals** August 10
 - **ReSwarm Science 1** August ?? TBD
 - **SmoothNav Science 3** September ?? TBD

 - **Increments 57/58 (October 2018 – April 2019)**
 - **Tether Slosh Science 4** TBD
 - **SmoothNav Science 4** TBD
 - **ReSwarm Science 2** TBD
 - **Zero Robotics High School Units Test** Oct 29
 - **Zero Robotics High School Dry Run** Jan 8, 2019
 - **Zero Robotics High School Finals** Jan 11, 2019
 - **Slosh Coating (4X ? Sessions)** TBD
 - **ASTROBEE (10x+ sessions)** TBD
-



SPHERES Calendar

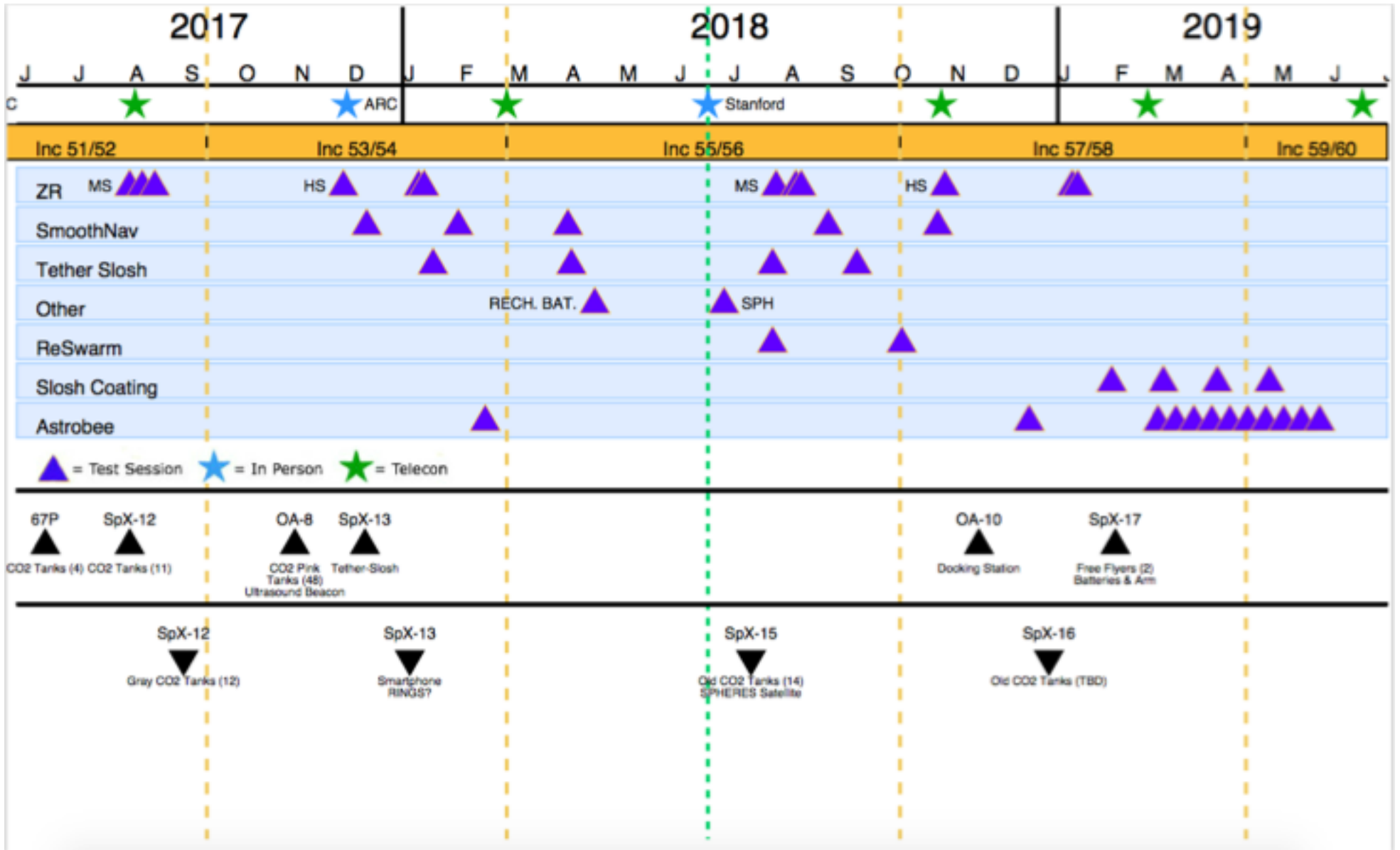



Safety and Verification

Safety

Completed and submitted:

- SPHERES Satellite Return (SpX-15) 6.30.18 – Approved 6.1.18
- SPHERES CO2 Tanks (gray) Return (SpX-15) 5.2.18 – Approved 5.3.18
- Smartphone Return (SpX-13) 1.11.2018 – Approved 1.12.18

Upcoming or in work

- SPHERES Gray CO2 Tanks (empty) Return (TBD)



Consumables Status

CO2 Tank Inventory

- **74 Tanks on orbit – should support approximately 22 test sessions**

Battery Pack Inventory

- **54 Batteries on orbit - should support approximately 8 test sessions**
- 10 SPHERES Rechargeable Batteries arrived on station with OA-7 (Feb 2017)

Consumables downmass

- Return 14 empty gray tanks (SpX-15)
- Return empty gray tanks (SpX-16)



SPHERES on Social Media

The screenshot shows the NASA SPHERES website. At the top, there is a navigation bar with links for Topics, Missions, Galleries, NASA TV, Follow NASA, Downloads, About, and NASA Audiences. Below this is a large banner image of three SPHERES satellites (blue, red, and orange) in space. The main content area is divided into several sections:

- Ames Research Center** (selected) | Overview | Images | Videos | Media Resources
- Follow** section with social media icons for Facebook, Twitter, Google+, YouTube, and Instagram.
- SPHERES Home** | Mission Overview | History | Satellites and Facilities | Partners and Affiliates | Guest Scientist Program | SPHERES Publications | FAQ | Archived Science | SPHERES Working Group
- Related Topics** | NASA Ames | Living in Space
- Article Teasers:**
 - Tether Slush:** Over a year after the first SPHERES Tether Demonstration Test Session was conducted on the International Space Station (ISS), researchers are aiming to expand their knowledge of tethering to captured objects and "space tug" chase vehicles in microgravity. In December 2017, a new investigation, called "Tether Slush," launched new hardware to the ISS on SpaceX-13 that will integrate with existing SPHERES, Tether, and Slush hardware on the ISS. Compared to the Tether Demonstration, the Tether Slush Investigation has added new mechanical features that will be tested with new sophisticated algorithms and modeling techniques for liquid sloshing in space vehicles. Two SPHERES satellites will be used to represent the capturing vehicles pulling a liquid tank inside the ISS Japanese Experiment Module to study the sloshing effects and better understand its fluid dynamics in microgravity.
 - SPHERES Shatters Own Record For Highest Operating Tempo in** (with image of an astronaut in the ISS)
 - What is SPHERES?** SPHERES consist of 3 free flying satellites on board the International Space Station that test a diverse range of hardware and software from scientist all over America. SPHERES has been active for 10 years and continues to be one of the most popular NASA projects and a favorite of many astronauts who are fortunate enough to work with the ISS.
 - SPHERES Zero Robotics High School 2016** On Wednesday January 4, 2017, the SPHERES Zero Robotics (ZR) Units Test session was performed on the International Space Station (ISS). This is the first of three ZR sessions for this month. The third session, planned for January 27, is a finale event in which teams of students will see their code run live on the ISS.
 - SPHERES Tether Demonstration** (with image of a satellite)
 - Tweets by @NASA_SPHERES**

Twitter

https://twitter.com/NASA_SPHERES

Website

<http://www.nasa.gov/spheres>

<http://www.nasa.gov/astrobee>

Astrobee Update



SPHERES/Astrobee Working Group
June 19, 2018



Astrobee Team

Oleg Alexandrov

Katie Browne

Maria Bualat

Brian Coltin

Earl Daley

Neil Davies

Lorenzo Fluckiger

Terry Fong

Jesse Fusco

Ryan Goetz

Yunkyung Kim

Dongmeng Li

John Love

Nghia Mai

Mike McIntyre

Don Morr

Ted Morse

Estrellina Pacis

Inwon Park

Greg Paulson

Hugo Sanchez

Trey Smith

Ernie Smith

Corey Snyder

The SPHERES Team

Andrew Symington

Omar Talavera

Vinh To

DW Wheeler

Shang Wu

Jongwoon Yoo

Alumni

Steve Battazzo

Jeff Blair

Jon Dewald

Jeff Feller

Ravi Gogna

Hyunjung Kim

Linda Kobayashi

Brian Koss

Alexandria Langford

Dong-Hyun Lee

Jason Lum

Andy Martinez

Blair Mclachlan

Zack Moratto

Robert Nakamura

Youngwoo Park

Cedric Priscal

Chris Provencher

Jay Torres

Allison Zuniga



Astrobee Equipment

- 3 free flyers, dock, spare ORUs on orbit
 - Honey (yellow)
 - Bumble (blue)
 - Queen (green)
- 3 free flyers, 2 docks (1 a flight spare), spares on ground
 - Melissa (pink)
 - B# (purple)
 - Killer (orange)

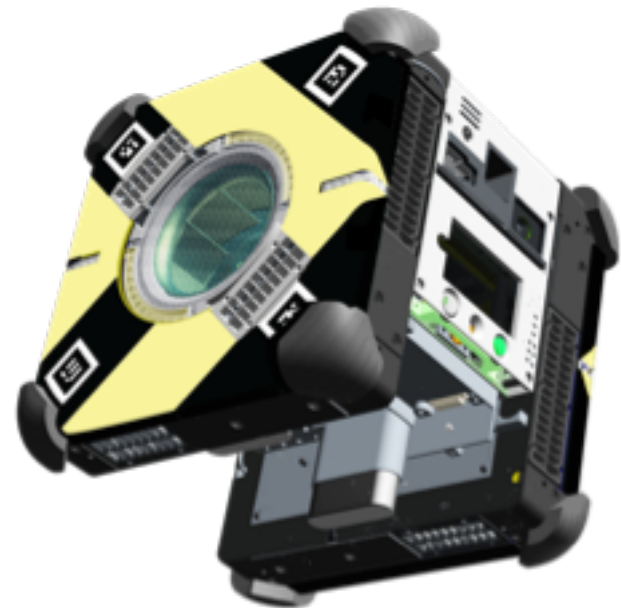



Research Scenario

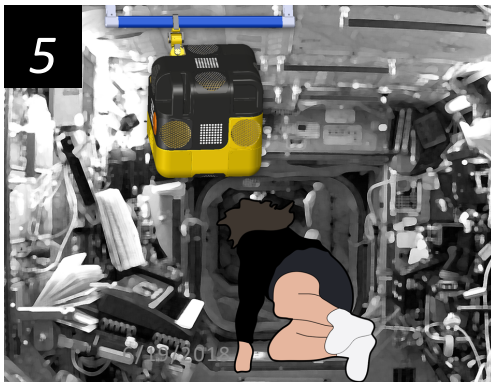
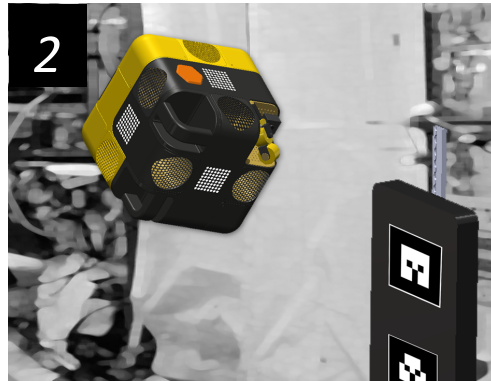

Sequence of Events

- 1 Prior to research activity, ground operator loads experimental software, free flyer does self-diagnostics.
- 2 Free flyer undocks and moves to experimental module.
- 3 Astronaut attaches external hardware to free flyer.
- 4 Ground operator sets up individual tests, and (optionally) astronaut initializes tests.
- 5 Free flyer perches to wait while astronaut pauses for EPO Event.
- 6 Astronaut detaches hardware and then free flyer returns to dock.



Research Scenario Timelines

- Low Intensity

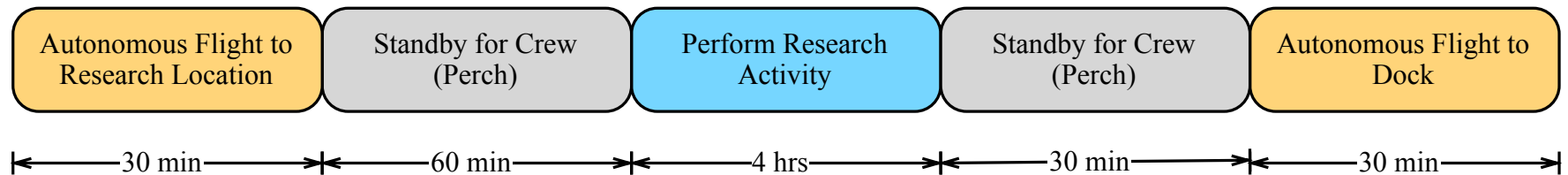

- High Intensity

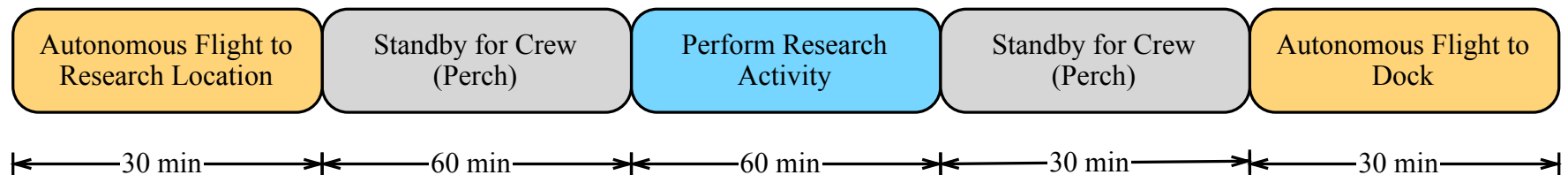



Contingencies

- Unexpected obstacle/crew
 - Stop and wait for instructions
- Low battery
 - Alert and autonomously return to dock
- LOS
 - Continue nominal operations
 - Long duration WiFi drop: return to dock
- H/W & S/W failures
 - Halt operations and disable propulsion, articulation and active sensing



Astrobee Status

- Astrobee hardware delivery has slipped
 - Addressing an electrical issue in the prop module
 - Dock to launch on Orbital-ATK 10 (November 17, 2018)
 - Honey and Bumble to launch on Space-X 17 (February 1, 2019)
 - Queen to launch on Orbital-ATK 11 (April 17, 2019)
- Nearly done with Cert Unit integration
 - All but prop module and final assembly of free flyer
- Flight Unit integration has begun
 - Completed hazcam and perchcam assemblies, and bumper assemblies and balanced impellers for 2 free flyers
 - Now concentrating on docking station integration
- Available to Guest Scientists:
 - Beta release of Flight Software/Simulator
 - Mechanical Payload ICD drawings
 - Initial draft of the Guest Science Guide



Astrobee Cert Unit Integration



Docking Station

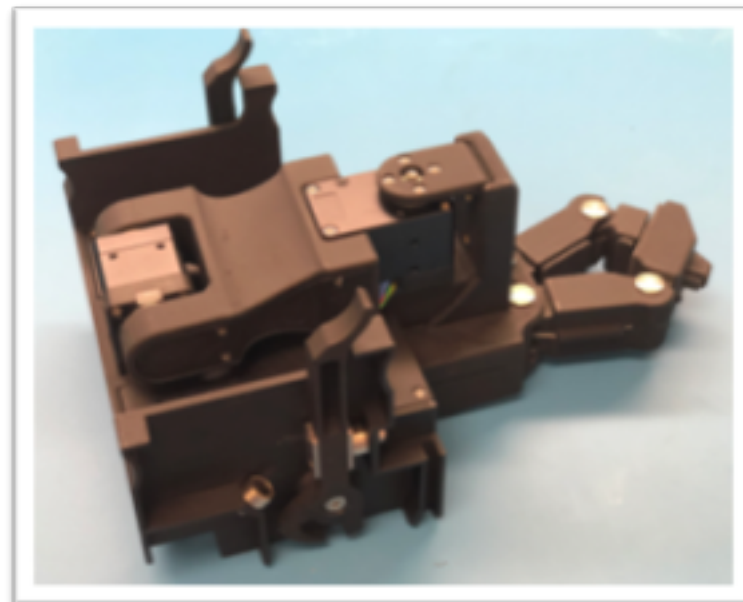

Perching Arm

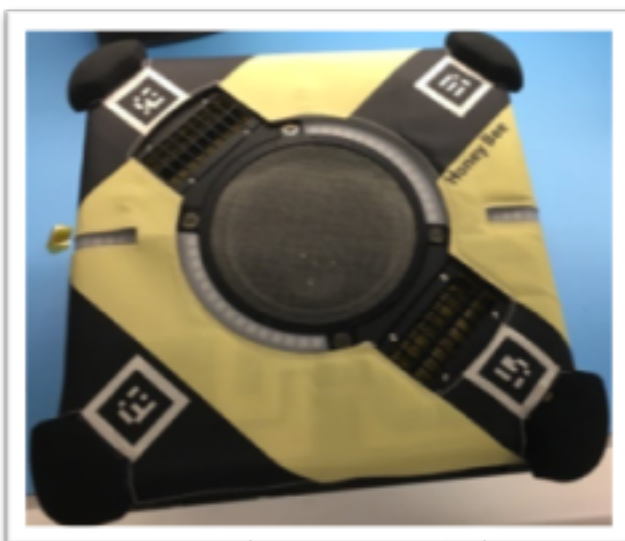

Propulsion Module



Top Forward Module



Astrobee Flight Unit Integration

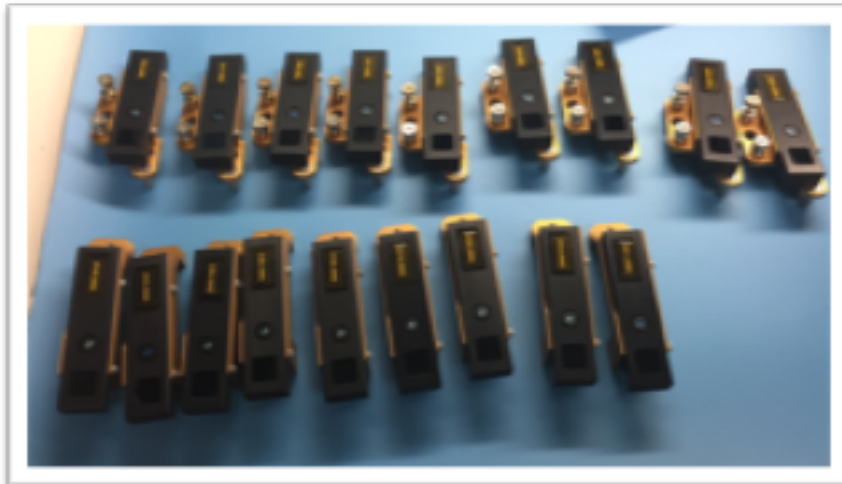

Hazcams & Perchcams



Bumper Assemblies



Core Frames